

Manual

Generator Protection & control
EuroProt+/DTRV

E12-GEN

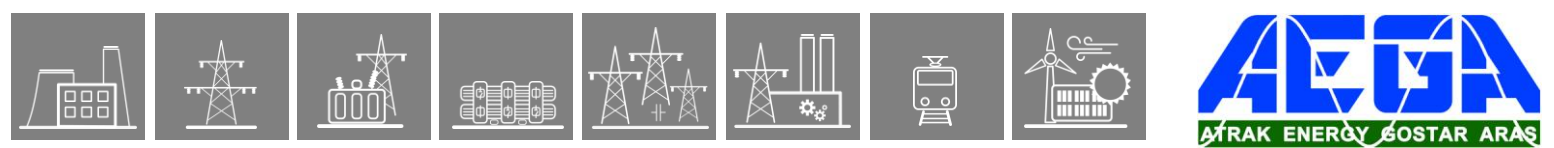

VERSION INFORMATION

NAME	DOCUMENT ID	VERSION	DATE
EuroProt+ DTRV type	PP-13-21886	1.0	2019-04-04
EuroProt+ Hardware description	PP-13-19958	2.0	2023-02-10
Impedance protection with compounded circular characteristic function	VERSION 1.0	1.0	2012-10-04
Overexcitation protection function	PP-13-22350	2.0	2021-05-21
Automatic generator synchronizer function	PP-13-21378	1.0	2016-12-21
Synchro check synchro switch function	VERSION 1.0	1.0	2011-06-27
Definite time undervoltage protection function	PP-13-21403	1.1	2017-01-11
Third harmonic undervoltage protection function	VERSION 1.0	1.0	2013-01-17
Directional overpower protection function	PP-13-22276	2.0	2021-01-06
Directional underpower protection function	PP-13-22277	2.0	2021-01-06
GGIORTD temperature measurement function	PP-13-21395	1.1	2017-01-09
Loss of excitation protection function (Version 40Q)	PP-13-20519	1.3	2016-04-20
Loss of excitation protection function (Version 40Z)	VERSION 1.1	1.1	2016-04-21
Negative sequence overcurrent protection	PP-13-20319	1.3	2022-08-09
Negative sequence overcurrent protection for generators function	PP-13-20518	1.1	2014-07-07
Negative sequence definite time overvoltage protection function	PP-13-20580	1.0	2014-08-26
Line thermal protection	VERSION 1.0	1.0	2011-10-25
Breaker failure protection	PP-13- 22253	2.1	2022-10-03
Three-phase Instantaneous Overcurrent Protection	PP-13-22489	2.0	2022-03-04
Residual Instantaneous Overcurrent Protection	PP-13-22488	2.1	2022-11-28
Generator inadvertent energizing protection function	PP-13-20520	1.2	2015-08-26
Three-phase overcurrent protection	PP-13-21408	2.4	2022-08-22
Residual overcurrent protection	PP-13-20320	1.3	2022-08-22
Interturn fault protection function (split phase/current based)	PP-13-21423	1.0	2017-02-13
Voltage dependent overcurrent protection function	PP-13-22395	2.0	2021-08-10
Definite time overvoltage protection function	PP-13-21400	1.2	2017-01-11
Residual definite time overvoltage protection function	VERSION 1.0	1.0	2011-06-27
Residual start-up overvoltage protection function	PP-13-21999	1.0	2020-12-11
Interturn fault protection function (voltage based)	PP-13-22000	1.0	2020-12-11
Third harmonic differential overvoltage protection function	PP-13-20521	1.1	2014-07-07
Rotor earth fault function and hardware description for isolated rotors	PP-13-21565	2.1	2020-12-11
Rotor earth fault function and hardware description for middle-grounded rotors	PP-13-22001	1.0	2020-12-11
Inrush current detection function	PP-13-22394	2.0	2021-08-10
Pole slipping protection function	PP-13-22519	2.1	2022-03-08
Overfrequency protection function	PP-13-21379	2.2	2021-07-30
Underfrequency protection function	PP-13-21379	2.2	2021-07-30
Rate of change of frequency function	PP-13-21385	2.1	2020-02-11
Current unbalance protection	PP-13-22163	2.0	2020-06-25
Restricted earth-fault protection	VERSION 1.0	1.0	2011-06-27
Differential protection	PP-13-21650	3.4	2023-03-14
Phase-Selective Trip Logic	PP-13-21531	2.0	2019-03-12

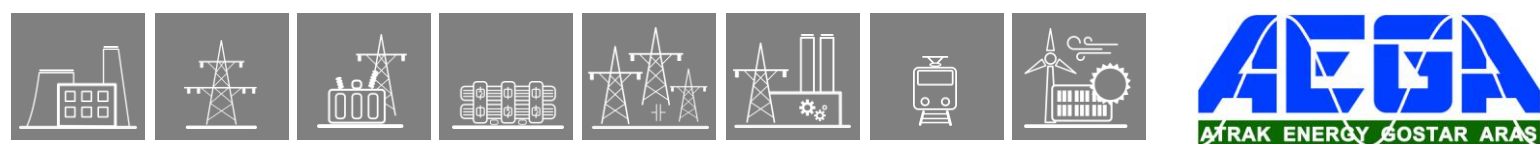

Setting guide to the voltage dependent overcurrent protection function	VERSION 1.0	1.0	2015-03-18
Setting guide to the loss of excitation protection (Version 40Q)	VERSION 1.0	1.0	2015-03-10
Setting guide to the third harmonic differential overvoltage protection	VERSION 1.0	1.0	2015-05-18
Circuit breaker wear monitoring	PP-13-21310	1.1	2016-09-06
Circuit Breaker control	PP-13-21877	2.0	2019-04-01
Disconnecter control	PP-13-20396	2.0	2019-04-01
Ethernet Links function	PP-13-21870	1.0	2019-02-19
Trip Circuit Supervision (TCS)	PP-13-21875	1.2	2019-08-09
Application of high-speed TRIP contacts	PP-13-21592	1.1	2017-10-02
Dead Line Detection Function	PP-13-22522	2.0	2022-03-04
Voltage transformer supervision and dead line detection	VERSION 1.1	1.1	2011-10-25
Current input function block setting guide	VERSION 1.1	1.0	2015-01-29
Voltage input function block setting guide	VERSION 1.0	1.0	2015-01-29
Line measurement Frequency measurement Voltage measurement Current measurement	PP-13-21168	2.3	2021-09-02
Disturbance recorder	PP-13-20368	3.0	2017-06-02
Average and maximum measurement function	PP-11-20109	1.0	2013-09-27
Metering function	PP-13-22238	2.1	2022-10-19
Trip value recorder function	PP-13-20947	2.1	2020-12-10
Voltage measurement selection function	VERSION 1.0	1.0	2013-02-06
Application guide to the differential protection and restricted earth-fault protection functions for autotransformers	-	1.1	2016-05-19
Differential protection function setting guide	-	1.0	2015-11-19
AIC current input function	PP-13-21392	1.0	2017-01-03
Remote I/O (RIO) server description	PP-13-22346	1.0	2021-06-02
Technical notes on EOB interoperability	-	1.0	2011-06-27
Maintenance guide	PP-13-226045	2.0	2022-11-18
RTD temperature input function	PP-13-21394	1.0	2017-01-03
EP+ Installation manual	PP-06-22516	1.0	2022-03-09
transcoder unit for transformer tap changer	PP-13-22348	1.0	2021-06-02

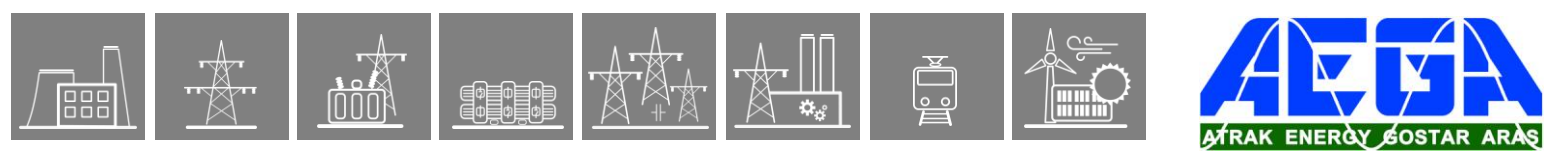
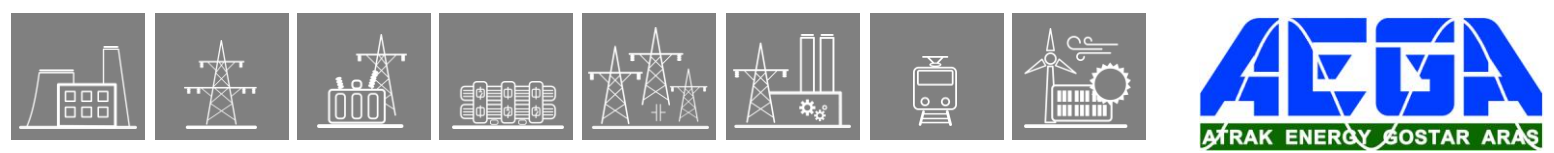
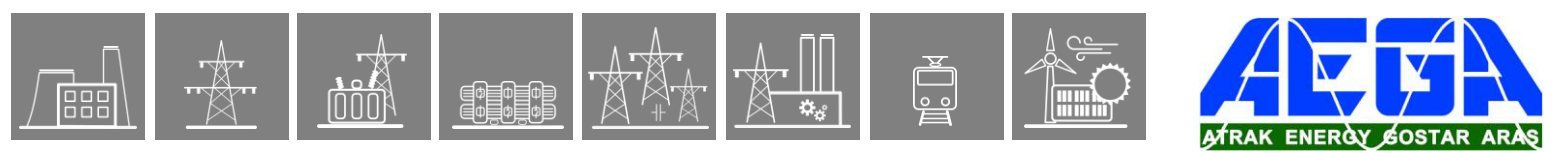

Table of Contents

1.	Introduction	7
1.1.	Application	7
1.1.1.	General features.....	7
1.2.	Pre-defined configuration variants	8
1.2.1.	System design.....	9
1.2.2.	CPU and COM module	10
1.2.3.	Device housings	30
1.2.4.	Human-Machine Interface (HMI) module	32
1.2.5.	Current input module	39
1.2.6.	Voltage input module.....	44
1.2.7.	Binary input module.....	46
1.2.8.	Signaling module	49
1.2.9.	Tripping module.....	52
1.2.10.	RTD input module.....	73
1.2.11.	Analog input module (AI)	75
1.2.12.	Analog output module (ATO)	77
1.2.13.	Sensor input module.....	79
1.2.14.	INJ module.....	81
1.2.15.	Generator protection modules	82
1.2.16.	Power supply module	85
1.2.17.	Sampling synchronization module	89
1.2.18.	Mixed function modules	90
1.2.19.	General data.....	100
1.2.20.	Mechanical data.....	102
1.2.21.	Mounting methods.....	105
1.2.22.	Product availability (special and obsolete modules)	125
1.2.23.	Remote I/O (RIO) server description.....	130
1.2.24.	Technical notes on EOB interoperability.....	139
1.2.25.	EP+ Installation manual	142
2.	Software configuration	150
2.1.	Protection functions	150
2.1.1.	Impedance protection with compounded circular characteristics.....	150
2.1.2.	Overexcitation protection function	179
2.1.3.	Generator synchronizer function.....	196
2.1.4.	Synchro check / synchro switch function	205
2.1.5.	Definite time undervoltage protection function	221
2.1.6.	Definite time third harmonic undervoltage protection function.....	229
2.1.7.	Directional over-power protection function.....	234
2.1.8.	Directional under-power protection function.....	240
2.1.9.	GGIORTD temperature measurement function	246
2.1.10.	Loss of excitation protection (Version 40Q)	253
2.1.11.	Loss of excitation protection.....	266
2.1.12.	Negative sequence overcurrent protection function	278
2.1.13.	Negative sequence overcurrent protection function for generators	289
2.1.14.	Negative sequence definite time overvoltage protection function.....	292
2.1.15.	Line thermal protection function	299
2.1.16.	Breaker failure protection	312



2.1.17.	Three-phase instantaneous Overcurrent Protection	321
2.1.18.	Residual Instantaneous Overcurrent Protection	330
2.1.19.	Generator inadvertent energizing protection	339
2.1.20.	Three-phase time overcurrent protection	342
2.1.21.	Residual overcurrent protection function	357
2.1.22.	Inter-turn fault protection function based on current measurement	366
2.1.23.	Voltage Dependent Overcurrent Protection	368
2.1.24.	Definite time overvoltage protection function	385
2.1.25.	Residual definite time overvoltage protection function	394
2.1.26.	Residual start-up overvoltage protection function	401
2.1.27.	Inter-turn fault protection function based on voltage measurement	409
2.1.28.	Third harmonic differential overvoltage protection function description	418
2.1.29.	Rotor Earth Fault protection for isolated rotors	442
2.1.30.	Rotor earth fault protection for middle-grounded rotors	457
2.1.31.	Inrush current detection function	465
2.1.32.	Pole Slipping Protection	470
2.1.33.	Over-frequency protection function	483
2.1.34.	Underfrequency protection function	487
2.1.35.	Rate of change of frequency protection function	491
2.1.36.	Differential protection function	495
2.1.37.	Restricted earth-fault protection function	554
2.2.	Control & supervision functions	594
2.2.1.	Phase-Selective Trip Logic	594
2.2.2.	Circuit breaker wear monitoring function	598
2.2.3.	Circuit breaker control function block	603
2.2.4.	Disconnecter control function	609
2.2.5.	Ethernet Links function	616
2.2.6.	Trip Circuit Supervision	619
2.2.7.	Dead Line Detection Function	626
2.2.8.	Voltage transformer supervision function	635
2.2.9.	Current unbalance function	650
2.3.	Measuring functions	656
2.3.1.	Current input function	658
2.3.2.	AIC current input function	663
2.3.3.	Voltage input function	665
2.3.4.	Line and frequency measurement functions	674
2.3.5.	Average and maximum measurement function	684
2.3.6.	Metering	686
2.3.7.	Voltage selection function block	692
2.3.8.	Trip Value Recorder	694
2.3.9.	RTD temperature input function	697
2.4.	Disturbance recorder function	700
2.4.1.	Mode of recording	700
2.4.2.	Format of recording	701
2.4.3.	Downloading and evaluating the disturbance records	701
2.4.4.	Parameters of the disturbance recorder functions	701
2.4.5.	The input signals of the disturbance recorder functions	702
2.4.6.	The function blocks	702
2.4.7.	The recorded signals	702



2.5.	Event recorder.....	703
3.	Maintenance guide for EuroProt+ devices	704
3.1.	Foreword.....	704
3.2.	Safety precautions	704
3.2.1.	General guidelines for a scheduled maintenance of EP+ devices	705
3.3.	Power supply maintenance	706
3.4.	Elements and Batteries	708



1. Introduction

The **DTRV** product type is a member of the **EuroProt+** product line, made by Protecta Co. Ltd. The **EuroProt+** complex protection in respect of hardware and software is a modular device. The modules are assembled and configured according to the requirements, and then the software determines the functions. This manual describes the **DTRV** product type.

1.1. Application

The **DTRV** products are designed for protection and control applications of power transformers and generators including generator-transformer blocks (these generator applications are handled independently).

The main application field of the **DTRV** type here is power transformers of any type with any vector group, whether it be two- or three-winding transformers, autotransformers at MV and/or HV voltage level.

The relays of this type support double breaker terminals such as breaker and a half or ring bus topology.

The main protection functions of the **DTRV** type include differential protection, overcurrent protections for both (or all three) sides, and voltage and frequency-based protections.

Additionally, the **DTRV** product type incorporates the control of tap changers / automatic voltage regulators by dedicated configuration variants.

Because of the implemented control, measuring and monitoring function, the IEDs can also be used as a bay control unit.

The **EuroCAP configuration tool**, which is available free of charge, offers a user-friendly and flexible application for protection, control and measurement functions to ensure that the IED-EP+ devices are fully customizable.

1.1.1. General features

- Native IEC 61850 IED with Edition 2 compatibility
- Scalable hardware to adapt to different applications
- 84 HP or 42HP wide rack size (height: 3U)
- The pre-defined factory configuration can be customized to the user's specification with the powerful EuroCAP tool
- Flexible protection and control functionality to meet special customer requirements
- Advanced HMI functionality via color touchscreen and embedded WEB server, extended measuring, control and monitoring functions
- User configurable LCD user screens, which can display SLDs (Single Line Diagrams) with switchgear position indication and control as well as measuring values and several types of controllable objects.
- Various protection setting groups available
- Enhanced breaker monitoring and control
- High capacity disturbance recorder (DRE) and event logging (data is stored in non-volatile memory):
 - DRE for up to 32 analogue and 64 digital signal channels.
 - Event recorder can store more than 10,000 events.
- Several mounting methods: Rack; Flush mounting; Semi-flush mounting; Wall mounting; Wall-mounting with terminals; Flush mounting with IP54 rated cover.
- Wide range of communication protocols:
 - Ethernet-based communication: IEC61850; IEC60870-5-104; DNP3.0 TCP; Modbus TCP
 - Serial communication: DNP3.0; IEC60870-5-101/103; MODBUS, SPA

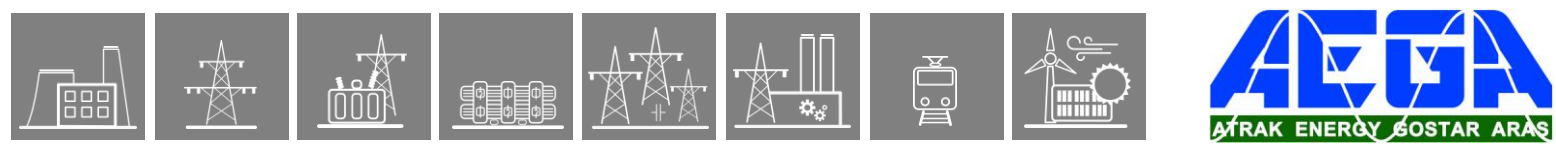

- The EuroProt+ family can handle several communication protocols simultaneously.
- Built-in self-monitoring to detect internal hardware or software errors
- Different time sources available: NTP server; Minute pulse; Legacy protocol master; IRIG-B000 or IRIG-B12X

1.2. Pre-defined configuration variants

The number and the functionality of the members of each product type is put together according to the application philosophy, keeping in mind the possible main usages. The available configurations of the DTRV type for transformers are listed in the table below.

VARIANT	MAIN APPLICATION
E0-Tr	Simplified protection for small transformers
E1-Tr	Two-winding transformer differential protection and control
E2-Tr	Two-winding transformer differential protection and control with voltage-based functions
E3-Tr	Two-winding transformer differential protection and control with voltage-based functions and automatic voltage regulator / tap changer controller
E4-Tr	Three-winding transformer differential protection and control
E5-Tr	Three-winding transformer differential protection and control with voltage-based functions
E6-Tr	Three-winding transformer differential protection and control with voltage-based functions and automatic voltage regulator / tap changer controller
E7-Tr	Automatic voltage regulator / tap changer controller

Table 1-1 The members of the DTRV type

Note that there are further members of the DTRV type, such as the E9, E10, E11 and E12 which are *generator protections* with several special functions, therefore they are handled separately from the ones listed here.

1.2.1. System design

The EuroProt+ protection device family is a scalable hardware platform to adapt to different applications. Data exchange is performed via a 16-bit high-speed digital non-multiplexed parallel bus with the help of a backplane module.

Each module is identified by its location and there is no difference between module slots in terms of functionality. The only restriction is the position of the CPU module because it is limited to the “CPU” position. The built-in self-supervisory function minimizes the risk of device malfunctions.

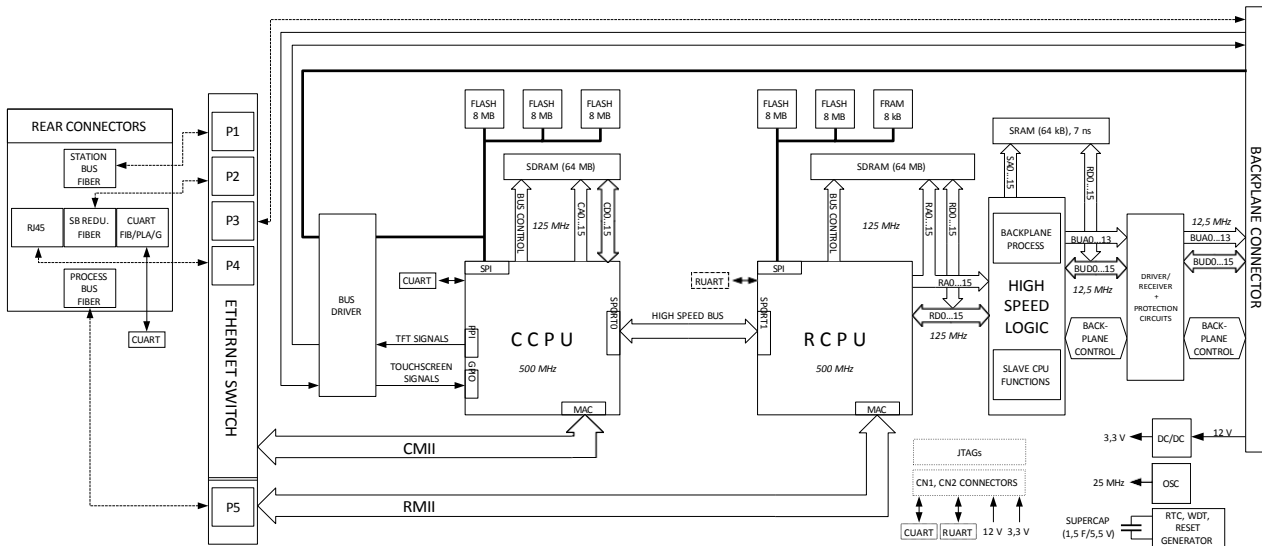
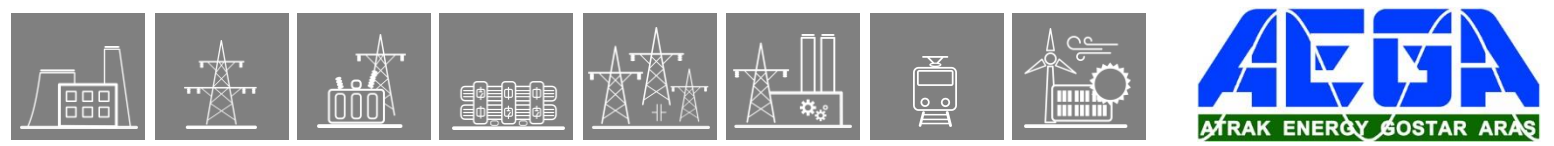

Figure 1-1 CPU block diagram

The backplane board itself is a passive board but it provides a 16-bit bus, power supply distribution, a two-wire interface (TWI) supporting module inventory management and module identification. It is designed to meet the requirements for high-speed digital buses and to comply with electromagnetic emission standards.



1.2.2. CPU and COM module

1.2.2.1. CPU+ module

The CPU module contains all the protection, control and communication functions of the EuroProt+ device. Dual 500 MHz high-performance Analog Devices Blackfin processors separate relay functions (RDSP) from communication and HMI functions (CDSP). Reliable communication between processors is performed via high-speed synchronous serial internal bus (SPORT).

Each processor has its own operative memory such as SDRAM and flash memories for configuration, parameter and firmware storage. Both firmwares are stored in a dedicated flash memory independent from the disturbance recorder and event storage.

The CDSP's operating system (uClinux) utilizes a robust JFFS flash file system, which enables fail-safe operation and the storage of disturbance record files, configuration and parameters.

The RDSP core runs at 500 MHz and its external bus speed is 125 MHz. The backplane data speed is limited to approx. 20 MHz, which is more than enough for module data throughput. An additional logic element (CPLD and SRAM) is used as a bridge between the RDSP and the backplane. The CPLD collects analogue samples from CT/VT modules and also controls signaling outputs and inputs.

CPU VERSION	PRIMARY STATION BUS SBW	SECONDARY (REDUNDANT) STATION BUS SBR	LEGACY PORT/PROTOCOL	PROCESS BUS (FIBER) PB	SERVICE PORT ON FRONT PANEL EOB/ RJ45
CPU+/0007	-	-	-	-	+
CPU+/0091	-	-	-	+ SM SH	+
CPU+/0201*	-	+ RJ45	-	-	+
CPU+/0211*	-	+ RJ45	-	+ MM	+
CPU+/0281*	-	+ RJ45	-	+ SM LH	+
CPU+/0291*	-	+ RJ45	-	+ SM SH	+
CPU+/0301	-	-	+ POF	-	+
CPU+/0401	-	-	+ GS	-	+
CPU+/0501*	-	-	+ Galv. RS485/422	-	+
CPU+/1001	+ MM	-	-	-	+
CPU+/1004	+ MM	-	-	-	+
CPU+/1011	+ MM	-	-	+ MM	+
CPU+/1091	+ MM	-	-	+ SM SH	+
CPU+/1101*	+ MM	+ MM	-	-	+
CPU+/1111	+ MM	+ MM	-	+ MM	+
CPU+/1181	+ MM	+ MM	-	+ SM LH	+
CPU+/1191	+ MM	+ MM	-	+ SM SH	+
CPU+/1201*	+ MM	+ RJ45	-	-	+
CPU+/1202	+ MM	+ RJ45	-	-	+
CPU+/1211	+ MM	+ RJ45	-	+ MM	+
CPU+/1281	+ MM	+ RJ45	-	+ SM LH	+
CPU+/1291*	+ MM	+ RJ45	-	+ SM SH	+
CPU+/1292	+ MM	+ RJ45	-	+ SM SH	+
CPU+/1301	+ MM	-	+ POF	-	+
CPU+/1311	+ MM	-	+ POF	+ MM	+
CPU+/1331	+ MM	-	+ double POF	-	+
CPU+/1381	+ MM	-	+ POF	+ SM LH	+
CPU+/1391	+ MM	-	+ POF	+ SM SH	+
CPU+/1401	+ MM	-	+ GS	-	+
CPU+/1411	+ MM	-	+ GS	+ MM	+
CPU+/1481	+ MM	-	+ GS	+ SM LH	+
CPU+/1491	+ MM	-	+ GS	+ SM SH	+
CPU+/1501	+ MM	-	+ Galv. RS485/422	-	+
CPU+/1511	+ MM	-	+ Galv. RS485/422	+ MM	+

CPU VERSION	PRIMARY STATION BUS (FIBER) SBW	SECONDARY (REDUNDANT) STATION BUS SBR	LEGACY PORT/PROTOCOL	PROCESS BUS (FIBER) PB	SERVICE PORT ON FRONT PANEL EOB/ RJ45
CPU+/1581	+ MM	-	+ Galv. RS485/422	+ SM LH	+
CPU+/1611	+ MM	-	+ Galvanic sync	+ MM	+
CPU+/1681	+ MM	-	+ Galvanic sync	+ SM LH	+
CPU+/6001	+ MM/LC	-	-	-	+
CPU+/6004	+ MM/LC	-	-	-	+
CPU+/6093	+ MM/LC	-	-	+ SM SH	+
CPU+/6094	+ MM/LC	-	-	+ SM SH	+
CPU+/6601*	+ MM/LC	+ MM/LC	-	-	+
CPU+/9201	+ SM SH	+ RJ45	-	-	+
CPU+/9291	+ SM SH	+ RJ45	-	+ SM SH	+
CPU+/9501	+ SM SH	-	+ Galv. RS485/422	-	+
CPU+/9901	+ SM SH	+ SM SH	-	-	+
CPU+/A001*	+ MM/LC PRP/HSR	-	-	-	+
CPU+/A004	+ MM/LC PRP/HSR	-	-	-	+
CPU+/A011	+ MM/LC PRP/HSR	-	-	+ MM	+
CPU+/A081	+ MM/LC PRP/HSR	-	-	+ SM LH	+
CPU+/A091	+ MM/LC PRP/HSR	-	-	+ SM SH	+
CPU+/A094	+ MM/LC PRP/HSR	-	-	+ SM SH	+

*Note: the modules can be equipped with a different handle (narrower and made of aluminum, instead of the standard plastic), if the other modules of the device are equipped with top-screw terminals (see Chapter 20.2). In these cases, a "T" letter appears on the label of the module (e.g. CPU+/1201T), but all other properties remain the same.

For legacy CPU cards (e.g. CPU+0001, ...) see [Product availability](#) chapter.

PRP/HSR option: A and F types can be ordered with PRP/HSR communication as sw option **Legend for CPU version table:**

MM: Multimode with ST connector	GS: Glass with ST connector
MM/LC: Multimode with LC connector	SFP: Small Form-factor Pluggable connector
SM: Single mode with FC/PC connector	SB: Station Bus
LH: Long Haul with FC/PC connector	SBW: Station Bus Working
SH: Short Haul with FC/PC connector	SBR: Station Bus Redundant
POF: Plastic Optical Fiber with 1 mm fiber connector	PB: Proprietary Process Bus

CPU+ 1511	CPU+ 1581	CPU+ 1611	CPU+ 1681	CPU+ 6001	CPU+ 6004	CPU+ 6093	CPU+ 6094	CPU+ 6601	CPU+ 9201	CPU+ 9291
MM/ST	MM/ST	MM/ST	MM/ST	MM/LC	MM/LC	MM/LC	MM/LC	MM/LC	SM SH FCPC	SM SH FCPC
Tx	Tx	Tx	Tx	Rx	Rx	Rx	Rx	Rx	Tx	Tx
SB	SB	SB	SB						SB	SB
Rx	Rx	Rx	Rx						Rx	Rx
Tx+ 1	Tx+ 1	-	-					MM/LC		
Tx- 2	Tx- 2	-	-					Rx	RJ-45	RJ-45
GND 3	GND 3	GND 3	GND 3							
Rx- 4	Rx- 4	Sy- 4	Sy- 4							
Rx+ 5	Rx+ 5	Sy+ 5	Sy+ 5							
MM/ST	SM LH FCPC	MM/ST	SM LH FCPC			SM SH FCPC	SM SH FCPC			SM SH FCPC
Tx	Tx	Tx	Tx			Tx	Tx			Tx
PB	PB	PB	PB			PB	PB			PB
Rx	Rx	Rx	Rx			Rx	Rx			Rx
CPU+ 9501	CPU+ 9901	CPU+ A001	CPU+ A004	CPU+ A011	CPU+ A081	CPU+ A091	CPU+ A094			
SM SH FCPC	SM SH FCPC	PRP/HSR MM/LC	PRP/HSR MM/LC	PRP/HSR MM/LC	PRP/HSR MM/LC	PRP/HSR MM/LC	PRP/HSR MM/LC			
Tx	Tx	Rx	Rx	Rx	Rx	Rx	Rx			
SB	PB	LAN A	LAN A	LAN A	LAN A	LAN A	LAN A			
Rx	Rx	Rx	Rx	Rx	Rx	Rx	Rx			
Tx+ 1	SM SH FCPC	LAN B	LAN B	LAN B	LAN B	LAN B	LAN B			
Tx- 2	Tx	LAN C	LAN C	LAN C	LAN C	LAN C	LAN C			
GND 3	PB	LAN D	LAN D	LAN D	LAN D	LAN D	LAN D			
Rx- 4	Rx	LAN E	LAN E	LAN E	LAN E	LAN E	LAN E			
Rx+ 5	Rx	LAN F	LAN F	LAN F	LAN F	LAN F	LAN F			
		A B I	A B I	A B I	A B I	A B I	A B I			
		LINK/ACT	LINK/ACT	LINK/ACT	LINK/ACT	LINK/ACT	LINK/ACT			
				MM/ST	SM LH FCPC	SM SH FCPC	SM SH FCPC			
				Tx	Tx	Tx	Tx			
				PB	PB	PB	PB			
				Rx	Rx	Rx	Rx			

Figure 2-1 CPU versions

Interface types:

- 100Base-FX Ethernet:
 - MM/ST 1300 nm, 50/62.5/125 μ m connector, (up to 2 km) fiber
 - SM/FC 1550 nm, 9/125 μ m connector, (LH: long haul, up to 120 km)
 - SM/FC 1550 nm, 9/125 μ m connector, (SH: short haul, up to 50 km)
 - MM/LC 1300 nm, 50/62.5/125 μ m connector, (up to 2 km) fiber
- 10/100 Base-TX Ethernet: RJ-45-8/8
- Service port on HMI:
 - 10/100 Base-T Ethernet: RJ-45-8/8
 - EOB2 interface: attachable to the front panel by a proprietary magnetic connector; the connector box ends in a RJ-45 8/8 plug. It is 10Base-T full duplex interface, and it enables 10/100Base TX communication with service computers.
- ASIF: Asynchronous Serial Interface
 - plastic optical fiber (ASIF-POF)
 - glass with ST connector (ASIF-GS)
 - galvanic RS485/422 (ASIF-G)

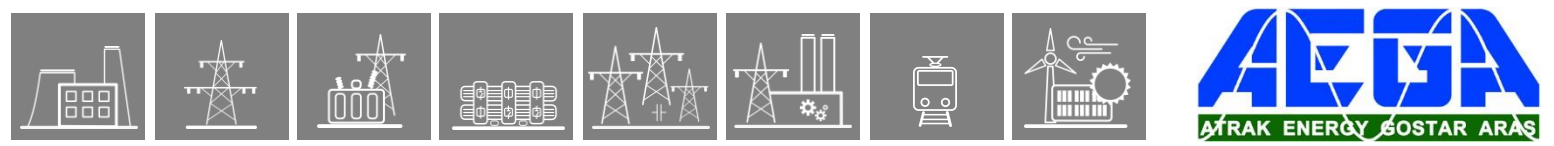

1.2.2.2. COM modules

The COM+ modules are responsible for special communication tasks, these are the following:

- binary signal transmission
- line differential protection communication via Ethernet or telecommunication networks
- busbar differential protection communication
- multi-port Ethernet switch using MODBUS/TCP protocol for Remote I/O (RIO) servers

1.2.2.2.1. COM modules for binary signal transmission

MODULE TYPE	INTERFACE TYPE	NUMBER OF INTERFACES	UNIT WIDTH	APPLICATION
COM+/1801*	MM/ST 1300 nm, 50/62.5/125 μm and SM/FC 1550 nm, 9/125 μm connector, 100Base-FX Ethernet	2	4 HP	Line differential protection, binary signal transmission up to 2 km and up to 120 km
COM+/1901*	MM/ST 1300 nm, 50/62.5/125 μm and SM/FC 1550 nm, 9/125 μm connector, 100Base-FX Ethernet	2	4 HP	Line differential protection, binary signal transmission up to 2 km and up to 50 km
COM+/8882	SM/FC 1550 nm, 9/125 μm connector, 100Base-FX Ethernet	3	4 HP	3 direction binary signal transmission up to 120 km
COM+/9902	SM/FC 1550 nm, 9/125 μm connector, 100Base-FX Ethernet	2	4 HP	2 direction binary signal transmission up to 50 km
COM+/9992	SM/FC 1550 nm, 9/125 μm connector, 100Base-FX Ethernet	3	4 HP	3 direction binary signal transmission up to 50 km

*Note: the modules can be equipped with a different handle (narrower and made of aluminum, instead of the standard plastic), if the other modules of the device are equipped with top-screw terminals (see Chapter 20.2). In these cases, a "T" letter appears on the label of the module (e.g. **COM+/1801T**), but all other properties remain the same

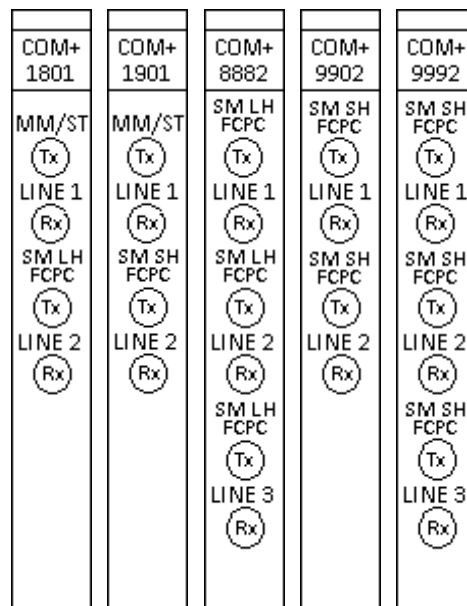

Figure 2-2 COM modules for binary signal transmission

1.2.2.2.3. COM modules for busbar differential protection communication

MODULE TYPE	INTERFACE TYPE	NUMBER OF INTERFACES	UNIT WIDTH	APPLICATION
COM+/1111	MM/ST 1300 nm, 50/62.5/125 μm connector, 100Base-FX Ethernet	3	4 HP	Busbar protection for 3 bay units up to 2 km
COM+/1111D	MM/ST 1300 nm, 50/62.5/125 μm connector, 100Base-FX Ethernet	3	4 HP	Busbar protection for 3x2 bay units (dual) up to 2 km

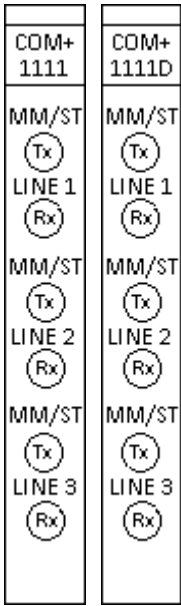

Figure 2-4 COM modules for busbar differential protections

1.2.2.2.4. COM modules for Remote I/O (RIO) servers

MODULE TYPE	INTERFACE TYPE	NUMBER OF INTERFACES	UNIT WIDTH	APPLICATION
COM+/1202*	MM/LC 1300 nm, 50/62.5/125 μm connector, 100Base-FX Ethernet	2	8 HP	2-port Ethernet switch for MODBUS via RIO
COM+/1324*	MM/LC 1300 nm, 50/62.5/125 μm connector, 100Base-FX Ethernet	4	8 HP	4-port Ethernet switch for MODBUS via RIO
COM+/1335	MM/LC 1300 nm, 50/62.5/125 μm connector, 100Base-FX Ethernet	5	8 HP	5-port Ethernet switch for MODBUS via RIO
COM+/6603	MM/LC 1300 nm, 50/62.5/125 μm connector, 100Base-FX Ethernet	2	4 HP	2-port Ethernet switch for MODBUS via RIO
COM+/6663	MM/LC 1300 nm, 50/62.5/125 μm connector, 100Base-FX Ethernet	3	4 HP	3-port Ethernet switch for MODBUS via RIO

*Obsolete module. These modules are not recommended for new designs!

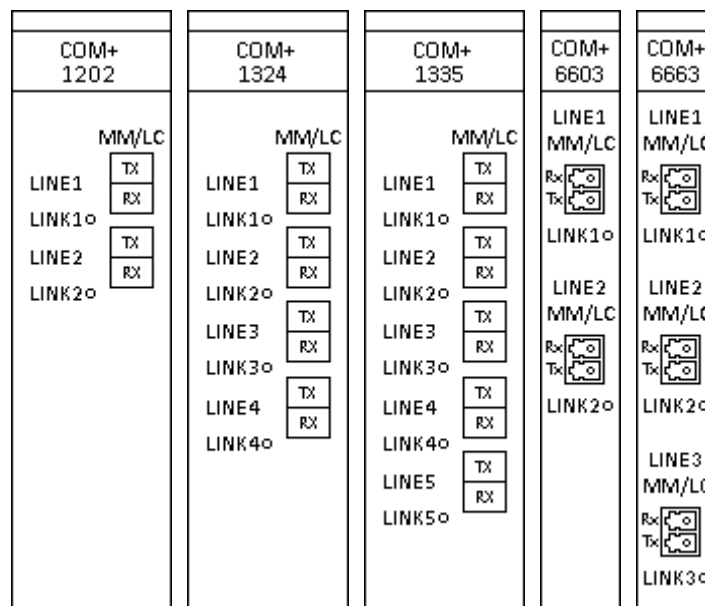

Figure 2-5 COM modules for RIO servers

1.2.2.3. Communication interface characteristics

1.2.2.3.1. Ethernet multi-mode transmitter and receiver

1.2.2.3.1.1. MM/ST connector

Up to approximately 2 km.

Transmitter

PARAMETER	SYMBOL	MIN.	TYP.	MAX.	UNIT
OPTICAL OUTPUT POWER 62.5/125 μm , NA = 0.275 FIBER	P_O	BOL*: -19 EOL*: -20	-	-14	dBm avg.
OUTPUT OPTICAL POWER 50/125 μm , NA = 0.20 FIBER	P_O	BOL*: -22.5 EOL*: -23.5	-	-14	dBm avg.
OPTICAL EXTINCTION RATIO	ER	-	-	10 -10	% dB
CENTER WAVELENGTH	λ_C	1270	1308	1380	nm

* BOL: Beginning of life, EOL: End of life

Note: according to field experiences, the 62.5/125 μm cabling is recommended for applications where the center wavelength is 1300/1310 nm.

Receiver sensitivity is measured with $2^{23} - 1$ PRBS pattern within BER = 2.5×10^{-10}

PARAMETER	SYMBOL	MIN.	TYP.	MAX.	UNIT
SIGNAL DETECT - ASSERTED	P_A	$P_D + 1.5 \text{ dB}$	-	-33	dBm avg.
SIGNAL DETECT - DEASSERTED	P_D	-45	-	-	dBm avg.
SIGNAL DETECT - HYSTERESIS	$P_A - P_D$	1.5	-	-	dB
SIGNAL DETECT ASSERT TIME (OFF TO ON)	AS_Max	0	2	100	μs
SIGNAL DETECT DEASSERT TIME (ON TO OFF)	ANS_Max	0	8	350	μs

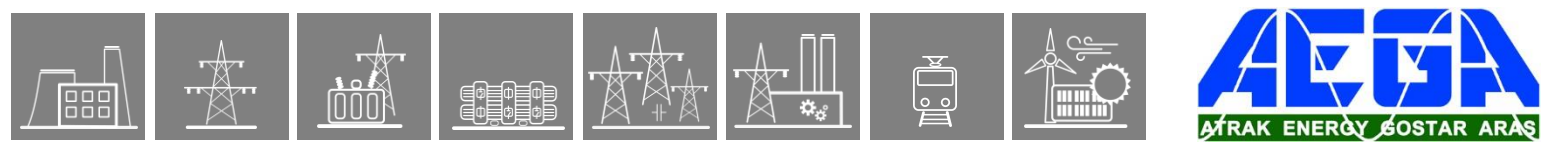

1.2.2.3.1.2. MM/LC connector

Up to approximately 2 km.

Transmitter

PARAMETER	SYMBOL	MIN.	TYP.	MAX.	UNIT
OPTICAL OUTPUT POWER** 62.5/125 μm , NA = 0.275 FIBER	P_O	BOL*: -19 EOL*: -20	-15.7	-14	dBm avg.
OUTPUT OPTICAL POWER 50/125 μm , NA = 0.20 FIBER	P_O	BOL*: -22.5 EOL*: -23.5	-	-14	dBm avg.
OPTICAL EXTINCTION RATIO	ER	-	0.002 -47	0.2 -27	% dB
CENTER WAVELENGTH	λ_C	1270	1308	1380	nm

* BOL: Beginning of life, EOL: End of life

Note: according to field experiences, the 62.5/125 μm cabling is recommended for applications where the center wavelength is 1300/1310 nm.

Receiver sensitivity is measured with $2^{23} - 1$ PRBS pattern within $\text{BER} = 2.5 \times 10^{-10}$

PARAMETER	SYMBOL	MIN.	TYP.	MAX.	UNIT
SIGNAL DETECT - ASSERTED	P_A	$P_D + 1.5 \text{ dB}$	-	-33	dBm avg.
SIGNAL DETECT - DEASSERTED	P_D	-45	-	-	dBm avg.
SIGNAL DETECT - HYSTERESIS	$P_A - P_D$	1.5	-	-	dB
SIGNAL DETECT ASSERT TIME (OFF TO ON)	AS_Max	0	2	100	μs
SIGNAL DETECT DEASSERT TIME (ON TO OFF)	ANS_Max	0	5	100	μs

1.2.2.3.2. Ethernet single mode transmitter and receiver

1.2.2.3.2.1. Long haul single mode transceiver

Up to approximately 120 km, with max. 32 dB link attenuation.

Transmitter

PARAMETER	SYMBOL	MIN.	TYP.	MAX.	UNIT
OPTICAL OUTPUT POWER	P_O	-6	-	0	dBm avg.
OPTICAL EXTINCTION RATIO	ER	8.3	-	-	dB
CENTER WAVELENGTH	λ_C	1490	1550	1610	nm

Receiver sensitivity is measured with $2^{23} - 1$ PRBS pattern within $BER = 2.5 \times 10^{-10}$

PARAMETER	SYMBOL	MIN.	TYP.	MAX.	UNIT
OPTICAL INPUT SENSITIVITY	P_{IN}	-	-38	-35	dBm avg.
SATURATION	P_{SAT}	-3	0	-	dBm
CENTER WAVELENGTH	λ_C	1100	-	1600	nm
SIGNAL DETECT - ASSERTED	P_A	-	-	-35	dBm avg.
SIGNAL DETECT - DEASSERTED	P_D	-45	-	-	dBm avg.
HYSTERESIS	P_{HYS}	-	3	-	dB

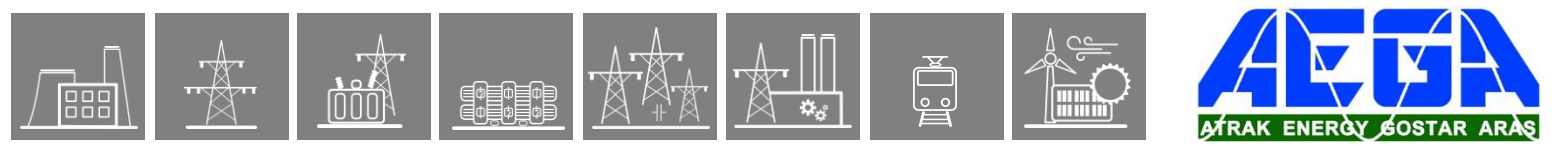

1.2.2.3.2.2. Short haul single mode transceiver

Up to approximately 50 km, with max. 27 dB link attenuation.

Transmitter

PARAMETER	SYMBOL	MIN.	TYP.	MAX.	UNIT
OPTICAL OUTPUT POWER	P_O	-12	-	-6	dBm avg.
OPTICAL EXTINCTION RATIO	ER	8.3	-	-	dB
CENTER WAVELENGTH	λ_C	1490	1550	1610	nm

Receiver sensitivity is measured with $2^{23} - 1$ PRBS pattern within $BER = 2.5 \times 10^{-10}$

PARAMETER	SYMBOL	MIN.	TYP.	MAX.	UNIT
OPTICAL INPUT SENSITIVITY	P_{IN}	-	-38	-35	dBm avg.
SATURATION	P_{SAT}	-3	0	-	dBm
CENTER WAVELENGTH	λ	1100	-	1600	nm
SIGNAL DETECT - ASSERTED	P_A	-	-	-35	dBm avg.
SIGNAL DETECT - DEASSERTED	P_D	-45	-	-	dBm avg.
HYSTERESIS	P_{HYS}	-	3	-	dB

1.2.2.3.3. ASIF-O transmitter and receiver

1.2.2.3.3.1. ASIF-O POF

Transmitter

PARAMETER	SYMBOL	MIN.	TYP.	MAX.	UNIT	JUMPER SETTINGS
TRANSMITTER OUTPUT OPTICAL POWER	P_T	-15.3	-	-9	dBm	JP1 2-3
		-23.3	-	-17		JP1 1-2
PEAK EMISSION WAVELENGTH	λ_{PK}	-	660	-	nm	
EFFECTIVE DIAMETER	D	-	1	-	mm	
NUMERICAL APERTURE	NA	-	0.5	-		

Receiver

PARAMETER	SYMBOL	MIN.	TYP.	MAX.	UNIT
INPUT OPTICAL POWER LEVEL LOGIC 0	$P_{R(L)}$	-39	-	-13.7	dBm
INPUT OPTICAL POWER LEVEL LOGIC 1	$P_{R(H)}$	-	-	-53	dBm
EFFECTIVE DIAMETER	D	-	1	-	mm
NUMERICAL APERTURE	NA	-	0.5	-	

These characteristics are valid for both POF interfaces in CPU+1331 module.

1.2.2.3.3.2. ASIF-O GLASS

Transmitter (Output measured out of 1 meter of cable)

PARAMETER	SYMBOL	MIN.	TYP.	MAX.	UNIT	JUMPER SETTINGS
50/125 μm FIBER CABLE NA = 0.2	P_o	-19.4	-16.4	-14.4	dBm peak	JP1 2-3
		-28.9	-25.9	-23.9		JP1 1-2
62.5/125 μm FIBER CABLE NA = 0.275	P_o	-15.6	-12.6	-10.6	dBm peak	JP1 2-3
		-22.9	-19.9	-17.9		JP1 1-2

Receiver

PARAMETER	SYMBOL	MIN.	TYP.	MAX.	UNIT
PEAK OPTICAL INPUT POWER LOGIC LEVEL HIGH ($\lambda_P = 820 \text{ nm}$)	P_{RH}	-25.4	-	-9.2	dBm peak
PEAK OPTICAL INPUT POWER LOGIC LEVEL LOW	P_{RL}	-	-	-40	dBm peak

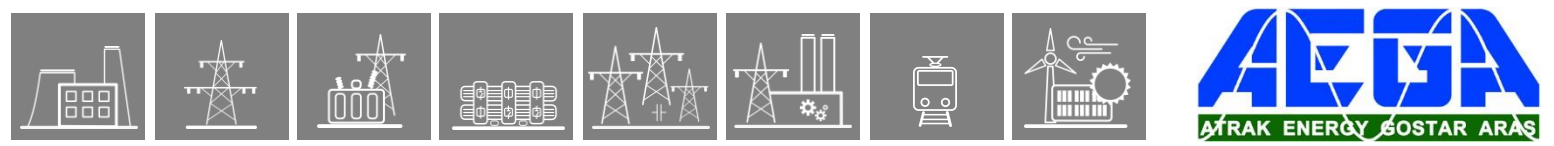

1.2.2.3.4. ASIF-G transmitter and receiver

The RS422/RS485 interfaces of our CPU+1501, CPU+1511, CPU+1581, CPU+9501 modules provide galvanic interface to support legacy or other serial protocols. For more details see our RS485/422 application note, available on our homepage.

Transmitter

PARAMETER	SYMBOL	MIN.	TYP.	MAX.	UNIT
DIFFERENTIAL OUTPUT VOLTAGE (LOADED, $R_L = 100 \Omega$, RS422)	V_{OD2}	2	-	3.6	V
DIFFERENTIAL OUTPUT VOLTAGE (LOADED, $R_L = 54 \Omega$, RS485)	V_{OD2}	1.5	-	3.6	V

Receiver

PARAMETER	SYMBOL	MIN.	TYP.	MAX.	UNIT
DIFFERENTIAL INPUT THRESHOLD VOLTAGE	V_{TH}	-200	-125	-30	mV
INPUT VOLTAGE HYSTERESIS	V_{HYS}	-	15	-	mV
LINE INPUT RESISTANCE	R_{IN}	96	-	-	k Ω

1.2.2.3.5. G.703 64 kbit/s co-directional interface (E0)

The EuroProt+ device also supports line differential communication via telecom networks using

- 64 kbit/s co-directional interface type through COM+0091. This type of communication is performed via 2 x 2 wire isolated galvanic type interface. The protection device is connected to a multiplexer or gateway which is responsible for protocol/speed conversion.

- Connector type: Weidmüller: Receptacle: S2L 3.50/12/90 F
Plug: B2L 3.50/12/180 F
- Impedance: 120 Ω
- Cable length: 50 m
- Interface type: G.703.1 64 kbit/s (E0) co-directional, selectable grounding, with optional external clock input

For further information about the cable assembly of this type of interface please see our G.703 E0 cable assembly guide.

Receiver

PARAMETER	VALUE
LOSS OF SIGNAL ALARM LEVEL	± 1.5 dB difference between alarm-on and alarm-off
DYNAMIC RANGE	10 dB maximum cable loss range

Transmitter

PARAMETER	VALUE
PAIR FOR EACH DIRECTION	± 1.5 dB difference between alarm-on and alarm-off
TEST LOAD IMPEDANCE	10 dB maximum cable loss range
NOMINAL PEAK VOLTAGE OF A “MARK” (PULSE)	One symmetric pair
PEAK VOLTAGE OF A “SPACE” (NO PULSE)	120 Ω resistive
NOMINAL PULSE WIDTH	1.0 V
RATIO OF THE AMPLITUDES OF POSITIVE AND NEGATIVE	0 V ± 0.10 V
PULSES AT THE CENTRE OF THE PULSES INTERVAL	3.9 ms
RATIO OF THE WIDTHS OF POSITIVE AND NEGATIVE PULSES	0.95 to 1.05
AT THE NOMINAL HALF AMPLITUDE	0.95 to 1.05
MAXIMUM PEAK-TO-PEAK JITTER AT THE OUTPUT PORT	Refer to clause 2/G.823

1.2.2.3.5.1. PRP/HSR redundant Ethernet communication interface

The PRP/HSR redundant Ethernet communication interface supports the two new IEC 62439-3 protocols which provide seamless redundancy for Ethernet networking in substations with zero-time recovery in case of a single failure without frame loss:

- PRP – Parallel Redundancy Protocol (IEC 62439-3 Clause 4)
- HSR – High-availability Seamless Redundancy (IEC 62439-3 Clause 5)

This interface uses two MM/LC connectors for double connection to networks as these protocols are based on the duplication of the sent frames.

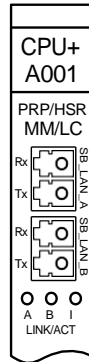

Figure 2-6 PRP/HSR connectors on a CPU+A001 module

1.2.2.3.5.2. Parallel Redundancy Protocol (PRP)

This redundancy protocol implements redundancy in the nodes as they are connected to two independent networks (LAN_A and LAN_B) sending a copy of each frame to both directions. The destination node receives and processes the first copy and discards the other copy of the sent frame.

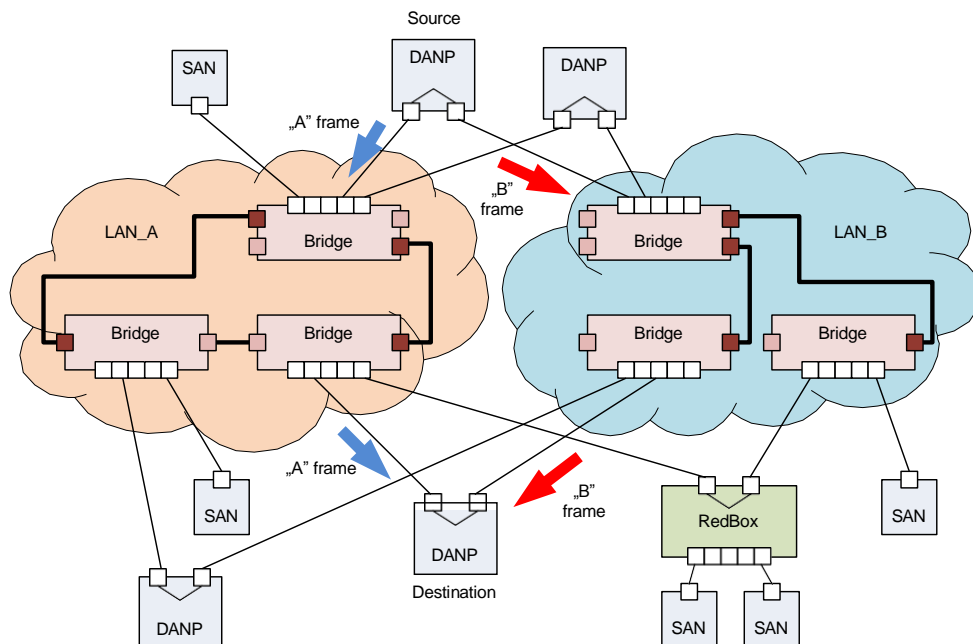

Figure 2-7 Example of a PRP redundant network

Single attached node (SAN): Network device that connects to a network with only one port.
 Double attached node implementing PRP (DANP): Network device which connects to a network with two ports implementing PRP redundancy.

1.2.2.3.5.3. High-availability Seamless Redundancy (HSR)

An HSR network provides redundancy with the same safety as PRP does with a lower cost. The principle of this protocol is also based on the duplication of the sent frames but in this solution the nodes are connected to a closed ring. A source node sends two copy of a frame to both direction and the destination node accepts the first received copy and discards the other one. If a frame returns to its source the node does not let it through itself prevent the possibility of an overload of the ring.

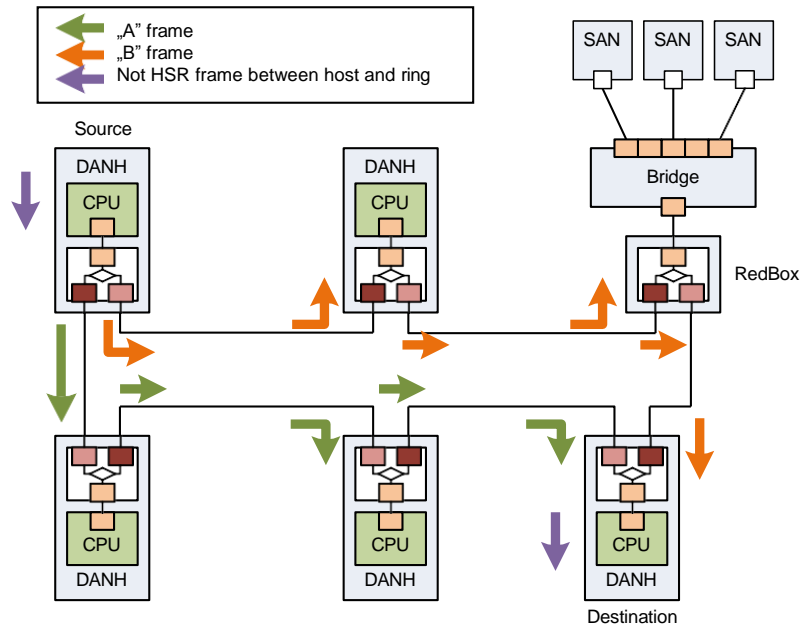
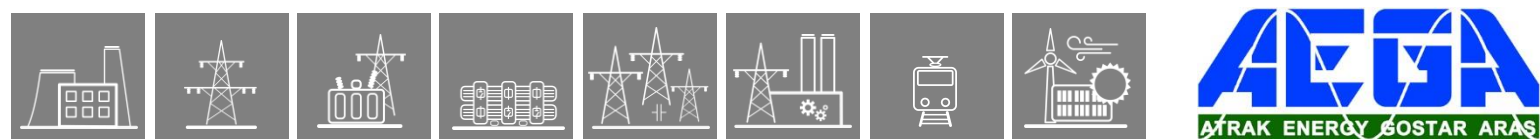

Figure 2-8 Example of an HSR redundant network

Single attached node (SAN): Network device that connects to a network with only one port.
Double attached node implementing HSR (DANH): Network device which connects to a network with two ports implementing HSR redundancy.



1.2.3. Device housings

Three+one versions are available: one is 84 HP wide with 21 module slots, the 42 HP wide, which supports 10 module slots, the double 42 HP wide with 20 module slots, and finally the 24 HP, which supports 6 module slots.

Depending on the installed modules of the configuration, the top and bottom panels of the 84 HP and 42 HP racks can be either solid (default) or perforated by 2 mm holes to prevent overheating. 24 HP housings do not have this feature, as the S24 system is less flexible, their range of the optional modules are narrower.

RACK CONFIGURATION	FREE MODULE SLOTS*	BOTTOM AND TOP PANELS	DISPLAY OPTIONS
84 HP, SINGLE RACK (3 U)	20	Solid, Perforated	3.5" TFT, 5.7" TFT
42 HP, SINGLE RACK (3 U)	9	Solid, Perforated	3.5" TFT, 5.7" TFT
42 HP, DOUBLE RACK (6 U)	19	Solid, Perforated	3.5" TFT
24 HP, PANEL INSTRUMENT CASE	5	Solid	B/W alphanumeric 3.5" TFT

**CPU module is mandatory, it uses up one fixed position*

Previously, a new rack type has been introduced to the 42HP devices. As of April 2021. this type is introduced to the 84HP devices as well. The depth of the box has been reduced from 242 mm to 223 mm. By default, this reduced-depth housing shall be used for newly manufactured devices. For more information about the previous and new size, see Chapter 22.1.

The following images showcase examples of the different types of available device housings with different kinds of front panel HMI. The available front panels are listed in Chapter 4.





<p>84 HP single rack (3 U) with 3.5" TFT display and solid housing</p>	
<p>84 HP single rack (3 U) with 5.7" TFT display and perforated housing</p>	
<p>42 HP single rack (3 U) with 3.5" TFT display and solid housing</p>	
<p>42 HP double rack (6 U) with 3.5" TFT display and solid housing</p>	
<p>24 HP panel instrument case with B/W display (left) TFT display (right)</p>	



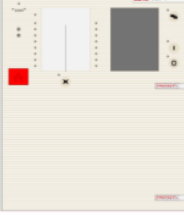



Figure 3-1 Rack configuration illustrations

1.2.4. Human-Machine Interface (HMI) module

The EuroProt+ device HMI consists of the following two main parts:





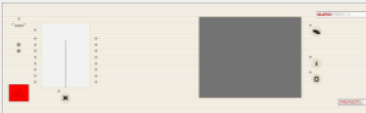



- Hardware: the HMI module, which is the front panel of the device, this is described here
- Software: the embedded web server and the menu system that is accessible through the HMI module. The web server is accessible via station bus, EOB interface or RJ-45 Ethernet connector. This is described in detail in the [Operating Manual](#) (external document).

1.2.4.1. Local HMI modules

MODULE TYPE	DISPLAY	SERVICE PORT	RACK SIZE	RACK DEPTH	ILLUSTRATION
HMI+/3505 HMI+/3405*	3,5" TFT	EOB	42 HP	Reduced	
			84 HP		
HMI+/3506 HMI+/3406* HMI+/3404*	3,5" TFT	RJ-45	42 HP	Reduced	
			Double 42HP		
			84 HP		
HMI+/5005	5,7" TFT	EOB	42 HP	Reduced	
HMI+/5006 HMI+/5004*	5,7" TFT	RJ-45	42 HP	Reduced	
			Double 42 HP		n/a
HMI+/5706 HMI+/5704*	5,7" TFT	RJ-45	84 HP	Reduced	

*new display hardware requires CDSP firmware version 1560-H5 or higher!

The following modules were made for the previous (now obsolete) racks (see Chapter 22.1), so they can be found in numerous devices. These became obsolete as well, **they are not recommended for new designs!**

MODULE TYPE	DISPLAY	SERVICE PORT	RACK SIZE	RACK DEPTH	ILLUSTRATION
HMI+/3501	3,5" TFT	EOB	42 HP	Normal	
			84 HP		
HMI+/3502	3,5" TFT	RJ-45	42 HP	Normal	
			84 HP		
HMI+/5001	5,7" TFT	EOB	42 HP	Normal	
HMI+/5002	5,7" TFT	RJ-45	42 HP	Normal	
HMI+/5701	5,7" TFT	EOB	84 HP	Normal	
HMI+/5702	5,7" TFT	RJ-45	84 HP	Normal	

1.2.4.2. Remote HMI

Protecta provides an alternative solution in that case if the IED can be only mounted in a non-practical way for managing the device via usual Human-Machine Interface.

By using a remote HMI (*terminal HMI device*), customers can place the HMI up to 3 meters far from the IED itself (*host device*) and mount the IED in any possible way that is applicable. The connection between the remote HMI and the IED is provided by a custom galvanic interface with DA-15 connector on the remote side.





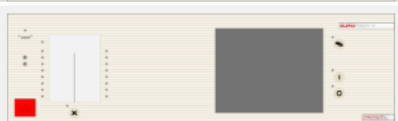

Figure 4-1 42 HP Remote HMI

Depending on the size of the HMI module you can use any applicable mounting methods that described in the [Mounting methods](#) chapter (Flush mounting, Semi-flush mounting, Rack mounting).



Figure 4–2 Remote HMI module with its host device

MODULE TYPE	DISPLAY	SERVICE PORT	RACK SIZE	RACK DEPTH	ILLUSTRATION
HMIT+/3505	3,5" TFT	EOB	42 HP	Reduced	
			84 HP		
HMIT+/3506	3,5" TFT	RJ-45	42 HP	Reduced	
			84 HP		
HMIT+/5706	5,7" TFT	RJ-45	84 HP	Reduced	



The following modules were made for the previous (now obsolete) racks (see Chapter 22.1), so they can be found in numerous devices. These became obsolete as well, **they are not recommended for new designs!**

MODULE TYPE	DISPLAY	SERVICE PORT	RACK SIZE	RACK DEPTH	ILLUSTRATION
HMIT+/3501	3,5" TFT	EOB	42 HP	Normal	
			84 HP		
HMIT+/3502	3,5" TFT	RJ-45	42 HP	Normal	
			84 HP		
HMIT+/5702	5,7" TFT	RJ-45	84 HP	Normal	

1.2.4.4. Parts of the HMI modules

The EuroProt+ device HMI on the front panel contains the following elements:

Function	Description
16 PIECES USER LEDs	Three-color, 3 mm circular LEDs
COM LED	Yellow, 3 mm circular LED indicating EOB/RJ-45 (on the front panel) communication link and activity
CAPACITIVE TOUCH KEY LEDs	4 pcs yellow, 3 mm circular LEDs indicating touch key actions
DEVICE STATUS LED	1 piece three-color, 3 mm circular LED Green: normal device operation Yellow: device is in warning state Red: device is in error state
DEVICE KEYS (I, O, X, PAGE)	Capacitive touch keys
	Tactile push buttons
BUZZER	Audible touch key pressure feedback
CHANGEABLE LED DESCRIPTION LABEL	Describes user LED functionality
DISPLAY	320 x 240 pixel TFT color display with resistive touchscreen interface (3.5" or optional 5.7")
	128 x 64 LCD black & white display
OPTICAL INTERFACE FOR FACTORY USAGE	For debugging and software development purposes <i>Only for 42 HP and 84 HP devices.</i>
EOB CONNECTOR	<p>Ethernet Over Board: communication interface accomplishes isolated, non-galvanic Ethernet connection with the help of a magnetically attached EOB device. The EOB device has an RJ-45 type connector supporting Ethernet connection to the user computer. This is a proprietary and patented solution from Protecta Ltd.</p> <p>EOB1: Supporting 10Base-T Ethernet connection. Passive device with one RJ45 type connector. Obsolete module.</p> <p>EOB2: Supporting 10/100Base-Tx Ethernet connection. An active device that has a USB port in addition to the RJ45 connector for powering up.</p>
ETHERNET SERVICE PORT	IP56 rated Ethernet 10/100-Base-T interface with RJ-45 type connector (IP56 only valid if the cap of the service port is closed.)

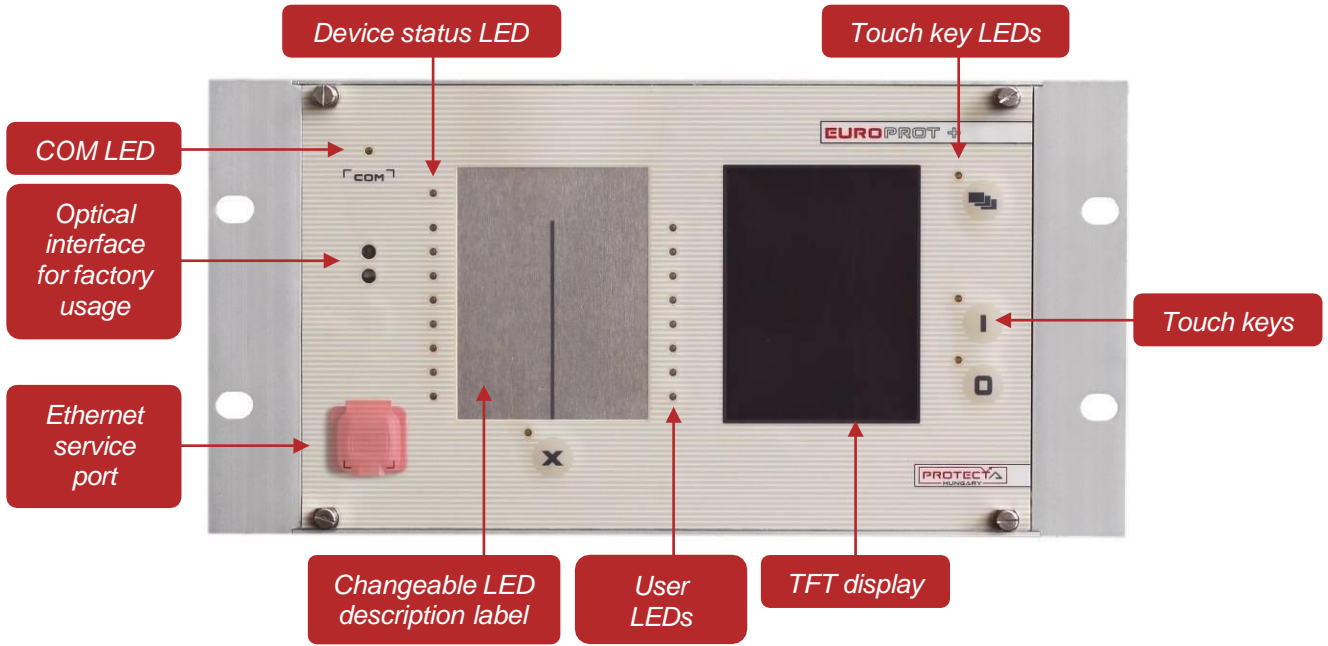

Figure 4–3 HMI signals and controls

LCD dot-defect handling policy

The definitions of dot-defect are as below:

- The defect area of the dot must be bigger than half of a dot.
- For bright dot-defect (sparkle mode), showing black pattern, the dot's brightness must be over 30 % brighter than others at black raster.
- For dark dot-defect (black mode), showing white pattern, the dot's brightness must be under 70 % darker than others at R.G.B. raster.

DOT-DEFECT TYPE		MAXIMUM NUMBER ACCEPTABLE	
		3.5"	5.7"
SPARKLE MODE	1 dot	4	4
	2 dots	2 (sets)	1
	IN TOTAL	4	5
BLACK MODE	1 dot	4	5
	2 dots	2 (sets)	2
	IN TOTAL	4	5
SPARKLE MODE AND BLACK MODE	2 dots	2 (sets)	n/a
IN TOTAL		6	10

For further information please contact our Application Team. (application@protecta.hu)

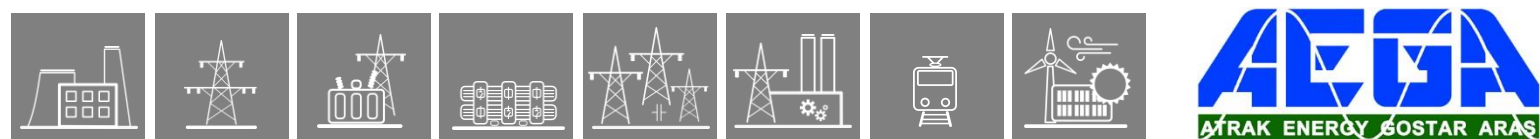

1.2.5. Current input module

This is an input module with intermediate current transformers to input the phase currents and the zero-sequence current. The rated current for the phase current and for the zero-sequence current can be selectable by parameter.

Main features:

- Rated frequency: 50 Hz, 60 Hz
- *Electronic* iron-core flux compensation

Connector types:

- *The default and optionally available connector types are indicated for each module in the tables below. See Chapter 20.2 for details about each type.*

MODULE TYPE	CT+/0101		CT+/1111*		CT+/1155		CT+/1500	
CHANNEL NUMBER	1 – 4		1 – 4		1 – 4		1 – 3	
SELECTABLE RATED CURRENT, I_N [A]	0.04	0.2	1	5	1	5	1	5
MAX. MEASURED CURRENT ($\pm 10\%$)	$8 \times I_N$		$50 \times I_N$		$12.5 \times I_N$		$2 \times I_N$	
POWER CONSUMPTION AT RATED CURRENT [VA]	0.005	0.1	0.01	0.25	0.02	0.45	0.1	1.55
THERMAL WITHSTAND [A]								
CONTINUOUSLY	7		20		20		7	
10 s	50		175		120		50	
1 s	150		500		380		150	
10 ms	330		1200		850		330	
CONNECTOR TYPE	<u>Default:</u> STVS <u>Options:</u> -		<u>Default:</u> STVS <u>Options:</u> -		<u>Default:</u> STVS <u>Options:</u> -		<u>Default:</u> STVS <u>Options:</u> R	
RECOMMENDED APPLICATION	DEFL earth fault protection		Special disturbance recorder application in wider frequency range		Special protection applications where the overcurrent in the secondary circuit can not exceed $10 \times I_N$		General three-phase measurement	

***Obsolete module. These modules are not recommended for new designs!**

MODULE TYPE	CT+/1515*		CT+/2500*		CT+/5101			
CHANNEL NUMBER	1 – 4		1 – 3		1 – 3		4	
SELECTABLE RATED CURRENT, I_N [A]	1	5	1	5	1	5	0.2	1
MAX. MEASURED CURRENT ($\pm 10\%$)	$2 \times I_N$		$2 \times I_N$		$50 \times I_N$		$12.5 \times I_N$	
POWER CONSUMPTION AT RATED CURRENT [VA]	0.1	1.55	0.1	1.55	0.01	0.25	0.005	0.1
THERMAL WITHSTAND [A]								
CONTINUOUSLY	7		7		20		7	
10 s	50		50		175		50	
1 s	150		150		500		150	
10 ms	330		330		1200		330	
CONNECTOR TYPE	<u>Default:</u> STVS <u>Options:</u> -		<u>Default:</u> STVS <u>Options:</u> -		<u>Default:</u> STVS <u>Options:</u> -			
RECOMMENDED APPLICATION	Special disturbance recorder application		Generator protections		Extremely sensitive earth-fault applications			

***Obsolete module. These modules are not recommended for new designs!**

MODULE TYPE	CT+/5102				CT+/5111*			
CHANNEL NUMBER	1 – 3		4		1 – 3		4	
SELECTABLE RATED CURRENT, I_N [A]	1	5	0.2	1	1	5	0.001	0.005
MAX. MEASURED CURRENT ($\pm 10\%$)	$50 \times I_N$		$50 \times I_N$		$50 \times I_N$		$50 \times I_N$	
POWER CONSUMPTION AT RATED CURRENT [VA]	0.01	0.25	0.001	0.01	0.01	0.25	0.005	0.1
THERMAL WITHSTAND [A]								
CONTINUOUSLY	20		20		20		7	
10 s	175		120		175		50	
1 s	500		380		500		150	
10 ms	1200		850		1200		330	
CONNECTOR TYPE	<u>Default:</u> STVS <u>Options:</u> -				<u>Default:</u> STVS <u>Options:</u> R			
RECOMMENDED APPLICATION	Sensitive earth-fault applications				Sensitive earth-fault applications			

***Obsolete module. These modules are not recommended for new designs!**

MODULE TYPE	CT+5115		CT+5116		CT+/5151		CT+/5152	
CHANNEL NUMBER	1 – 4		1 – 3		1 – 4		1 – 4	
SELECTABLE RATED CURRENT, I _N [A]	1	5	1	5	1	5	1	5
MAX. MEASURED CURRENT (± 10 %)	50 × I _N		50 × I _N		50 I _N		50 I _N	
POWER CONSUMPTION AT RATED CURRENT [VA]	0.01	0.25	0.01	0.25	0.01	0.25	0.01	0.25
THERMAL WITHSTAND [A]								
CONTINUOUSLY	20		20		20		20	
10 s	175		175		175		175	
1 s	500		500		500		500	
10 ms	1200		1200		1200		1200	
CONNECTOR TYPE	<u>Default:</u> STVS <u>Options:</u> R		<u>Default:</u> STVS <u>Options:</u> -		<u>Default:</u> STVS <u>Options:</u> R		<u>Default:</u> STVS <u>Options:</u> R	
RECOMMENDED APPLICATION	<ul style="list-style-type: none"> General protection applications* Three-phase measurement* 		High-impedance differential protection		General protection applications		Busbar protection bay units	

**The CT+/5115 module handles both applications: it can be connected to the protection and measurement core of the primary CT as well*

MODULE TYPE	CT+/5153					CT+/5154*				
CHANNEL NUMBER	1 – 3		4			1 – 3		4		
SELECTABLE RATED CURRENT, I _N [A]	1	5	1	0.2	0.2 sens.	1	5	5	1	0.2
MAX. MEASURED CURRENT (± 10 %)	50 × I _N			10 × I _N		50 × I _N			10 × I _N	
POWER CONSUMPTION AT RATED CURRENT [VA]	0.06	1.3	0.6	0.004	0.0004	0.06	1.3	1.3	0.06	0.004
THERMAL WITHSTAND [A]										
CONTINUOUSLY	20		7			20				
10 s	175		50			175				
1 s	500		150			500				
10 ms	1200		330			1200				
CONNECTOR TYPE	<u>Default:</u> STVS <u>Options:</u> R, T**					<u>Default:</u> STVS <u>Options:</u> R				
RECOMMENDED APPLICATION	General protection application, extremely sensitive transient earth-fault protections					General protection application, sensitive transient earth-fault protections				

***Obsolete module. These modules are not recommended for new designs!**

****The connector remains the same STVS, only the handle of the module becomes narrower and will be made of aluminum**

MODULE TYPE	CT+/5155*					CT+/5253**				
CHANNEL NUMBER	1 – 3		4			1 – 3		4		
SELECTABLE RATED CURRENT, I_N [A]	1	5	0.25	0.05	0.05 sens.	5	1	0.25	0.05	0.05 sens.
MAX. MEASURED CURRENT ($\pm 10\%$)	50 $\times I_N$			10 $\times I_N$		25 $\times I_N$				
POWER CONSUMPTION AT RATED CURRENT [VA]	0.06	1.3	0.6	0.004	0.0004	0.06	1.3	0.6	0.004	0.0004
THERMAL WITHSTAND [A]										
CONTINUOUSLY	20		7			20		7		
10 s	175		50			175		50		
1 s	500		150			500		150		
10 ms	1200		330			1200		330		
CONNECTOR TYPE	Default: STVS Options: -					Default: STVS Options: -				
RECOMMENDED APPLICATION	DMD Special sensitive earth fault protection					Circuit breaker diagnostics				

***Obsolete module. These modules are not recommended for new designs!**

****Special module**

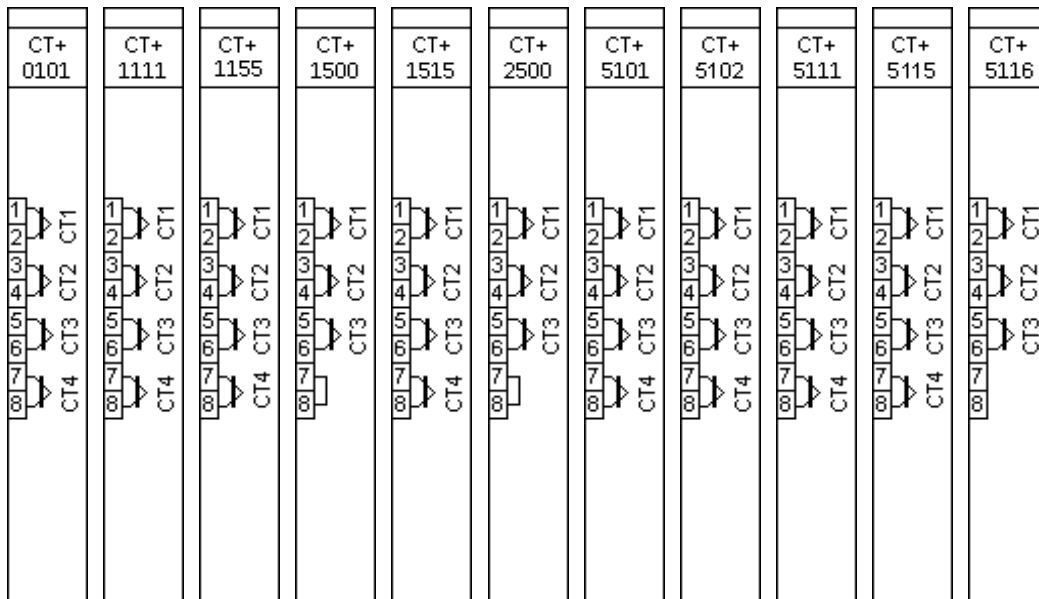

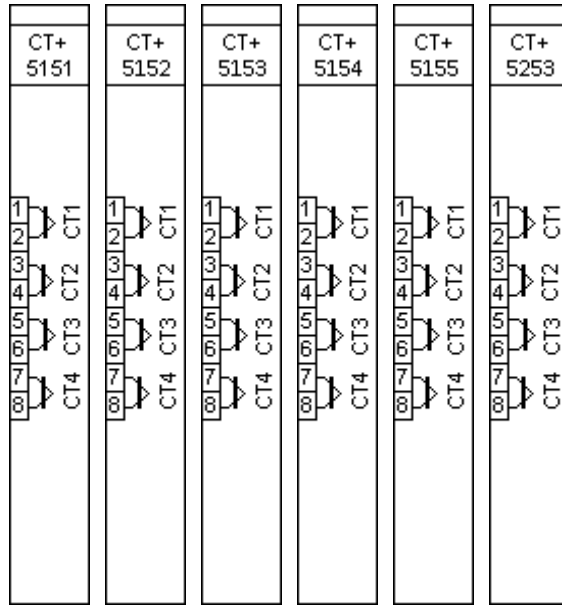
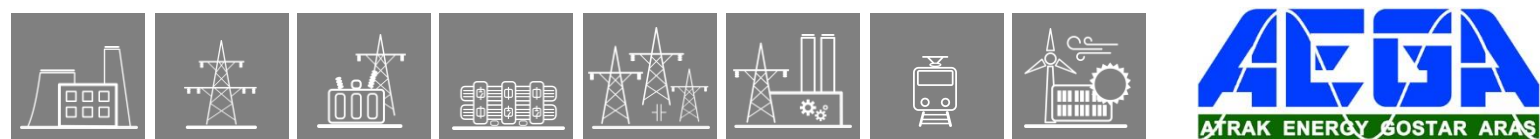

Figure 5-1 CT modules



1.2.6. Voltage input module

If the device performs voltage and/or frequency related functions and measurements (voltage protections, directional protections, frequency protections etc.), then this module is needed.

Connector types:

- The default and optionally available connector types are indicated for each module in the tables below. See Chapter 20.2 for details about each type.

MODULE TYPE	VT+/2211	VT+/2212*	VT+/2215**
CHANNEL NUMBER	4	4	4
SELECTABLE VOLTAGE RANGE	<u>Type 100:</u> $\frac{100}{\sqrt{3}}$, 100 V <u>Type 200:</u> $\frac{200}{\sqrt{3}}$, 200 V	<u>Type 100:</u> $\frac{100}{\sqrt{3}}$, 100 V <u>Type 200:</u> $\frac{200}{\sqrt{3}}$, 200 V	<u>Type 100:</u> $\frac{100}{\sqrt{3}}$, 100 V <u>Type 200:</u> $\frac{200}{\sqrt{3}}$, 200 V
CONTINUOUS VOLTAGE WITHSTAND	200 V	200 V	200 V
SHORT TIME OVERLOAD (1 s)	275 V (10s)	275 V	275 V
VOLTAGE MEASURING RANGE ($\pm 10\%$)	$0.05 U_N - 1.3 U_N$	$0.05 U_N - 1.3 U_N$	$0.05 U_N - 1.3 U_N$
POWER CONSUMPTION OF VOLTAGE INPUT	0.61 VA at 200 V 0.2 VA at 100 V	0.61 VA at 200 V 0.2 VA at 100 V	<u>ch. 1-3:</u> 0.61 VA at 200 V 0.2 VA at 100 V <u>ch. 4:</u> 50 mVA at 100 V
CONNECTOR TYPE	<u>Default:</u> BLA <u>Options:</u> F, T, R	<u>Default:</u> BLA <u>Options:</u> -	<u>Default:</u> BLA <u>Options:</u> -
RECOMMENDED APPLICATION	General protection applications.	Special disturbance recorder application in wider frequency range	Special protection applications with voltage transformers that require low power consumption on the 4 th channel.

***Obsolete module. These modules are not recommended for new designs!**

****Special module**

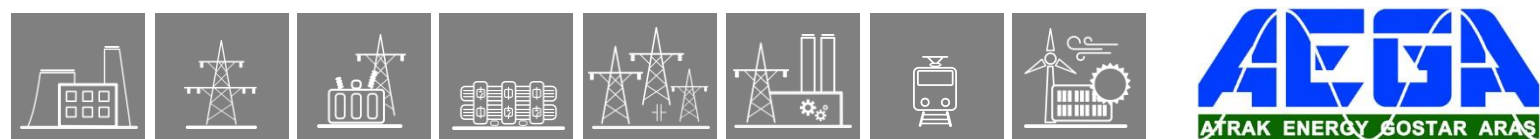

1.2.7. Binary input module

The inputs are galvanic isolated, and the module converts high-voltage signals to the voltage level and format of the internal circuits. The inputs of this module can be also programmed to serve as a PPM input for time synchronization.

Connector types:

- The default and optionally available connector types are indicated for each module in the tables below. See Chapter 20.2 for details about each type.

Notes for the following tables:

- **Thermal withstand voltage:** continuous with 60 % of the input channels are energized.
- **Clamp voltage:** these are the guaranteed values; the actual ones might differ from those provided here (falling and rising around $0.66 U_N$ and $0.77 U_N$, respectively)

MODULE TYPE	O8+/2401	O8+/4801	O8+/1101	O8+/2201
CHANNEL NUMBER	8	8	8	8
TIME SYNCHRONIZATION	configured by EuroCAP	configured by EuroCAP	configured by EuroCAP	configured by EuroCAP
RATED VOLTAGE	24 V	48 V	110 V	220 V
THERMAL WITHSTAND VOLTAGE	72 V	100 V	250 V	320 V
CLAMP VOLTAGE	falling $0.64 U_N$ rising $0.8 U_N$	falling $0.64 U_N$ rising $0.8 U_N$	falling $0.64 U_N$ rising $0.8 U_N$	falling $0.64 U_N$ rising $0.8 U_N$
COMMON GROUPS	independent	independent	independent	independent
CONNECTOR TYPE	<u>Default:</u> BLA <u>Options:</u> T	<u>Default:</u> BLA <u>Options:</u> T	<u>Default:</u> BLA <u>Options:</u> T	<u>Default:</u> BLA <u>Options:</u> T

MODULE TYPE	O12+/2401	O12+/4801	O12+/1101	O12+/2201
CHANNEL NUMBER	12	12	12	12
TIME SYNCHRONIZATION	configured by EuroCAP	configured by EuroCAP	configured by EuroCAP	configured by EuroCAP
RATED VOLTAGE	24 V	48 V	110 V	220 V
THERMAL WITHSTAND VOLTAGE	72 V	72 V	250 V	320 V
CLAMP VOLTAGE	falling $0.64 U_N$ rising $0.8 U_N$	falling $0.64 U_N$ rising $0.8 U_N$	falling $0.64 U_N$ rising $0.8 U_N$	falling $0.64 U_N$ rising $0.8 U_N$
COMMON GROUPS	4 × 3 common	4 × 3 common	4 × 3 common	4 × 3 common
CONNECTOR TYPE	<u>Default:</u> BLA <u>Options:</u> T	<u>Default:</u> BLA <u>Options:</u> F, T	<u>Default:</u> BLA <u>Options:</u> F, T	<u>Default:</u> BLA <u>Options:</u> T

MODULE TYPE	O12+/4201*	O12+/2101*	O15+/4801T	O15+/1101T
CHANNEL NUMBER	12	12	15	15
TIME SYNCHRONIZATION	configured by EuroCAP	configured by EuroCAP	configured by EuroCAP	configured by EuroCAP
RATED VOLTAGE	24 V DC / 48 V DC user selectable on channel basis by jumpers	110 V DC / 220 V DC user selectable on channel basis by jumpers	48 V	110 V
THERMAL WITHSTAND VOLTAGE	72 V	320 V	100 V	250 V
CLAMP VOLTAGE	falling 0.64 U _N rising 0.8 U _N	falling 0.64 U _N rising 0.8 U _N	falling 0.64 U _N rising 0.8 U _N	falling 0.64 U _N rising 0.8 U _N
COMMON GROUPS	4 × 3 common	4 × 3 common	1 × 15 common	1 × 15 common
CONNECTOR TYPE	<u>Default:</u> BLA <u>Options:</u> -	<u>Default:</u> BLA <u>Options:</u> T	BLT	BLT

• O12+2101 and O12+4201 modules can be used only in demonstration applications! For further information see our [Product availability](#) chapter.

MODULE TYPE	O16+/2401*	O16+/4801*	O16+/1101*	O16+/2201*
CHANNEL NUMBER	16	16	16	16
TIME SYNCHRONIZATION	-	-	-	-
RATED VOLTAGE	24 V	48 V	110 V	220 V
THERMAL WITHSTAND VOLTAGE	72 V	100 V	250 V	320 V
CLAMP VOLTAGE	falling 0.64 U _N rising 0.8 U _N	falling 0.64 U _N rising 0.8 U _N	falling 0.64 U _N rising 0.8 U _N	falling 0.64 U _N rising 0.8 U _N
COMMON GROUPS	2 × 8 common	2 × 8 common	2 × 8 common	2 × 8 common
CONNECTOR TYPE	<u>Default:</u> BL 3.5 <u>Options:</u> -	<u>Default:</u> BL 3.5 <u>Options:</u> -	<u>Default:</u> BL 3.5 <u>Options:</u> -	<u>Default:</u> BL 3.5 <u>Options:</u> -

*Obsolete module. These modules are not recommended for new designs! O15+ modules are recommended instead (see above).

Main features:

- Digitally filtered per channel
- Current drain:
 - max. 1.6 mA per channel at 220 V DC
 - max. 1.8 mA per channel at 110 V DC
 - max. 2 mA per channel at 48 V DC
 - max. 3 mA per channel at 24 V DC
- In such applications where the input voltage is 60 V the modules with 48 V rated voltage can be used.
- Input voltage type can be either DC or AC voltage. If AC voltage is used make sure that the type and the parameters of the binary inputs are configured properly in EuroCAP tool.

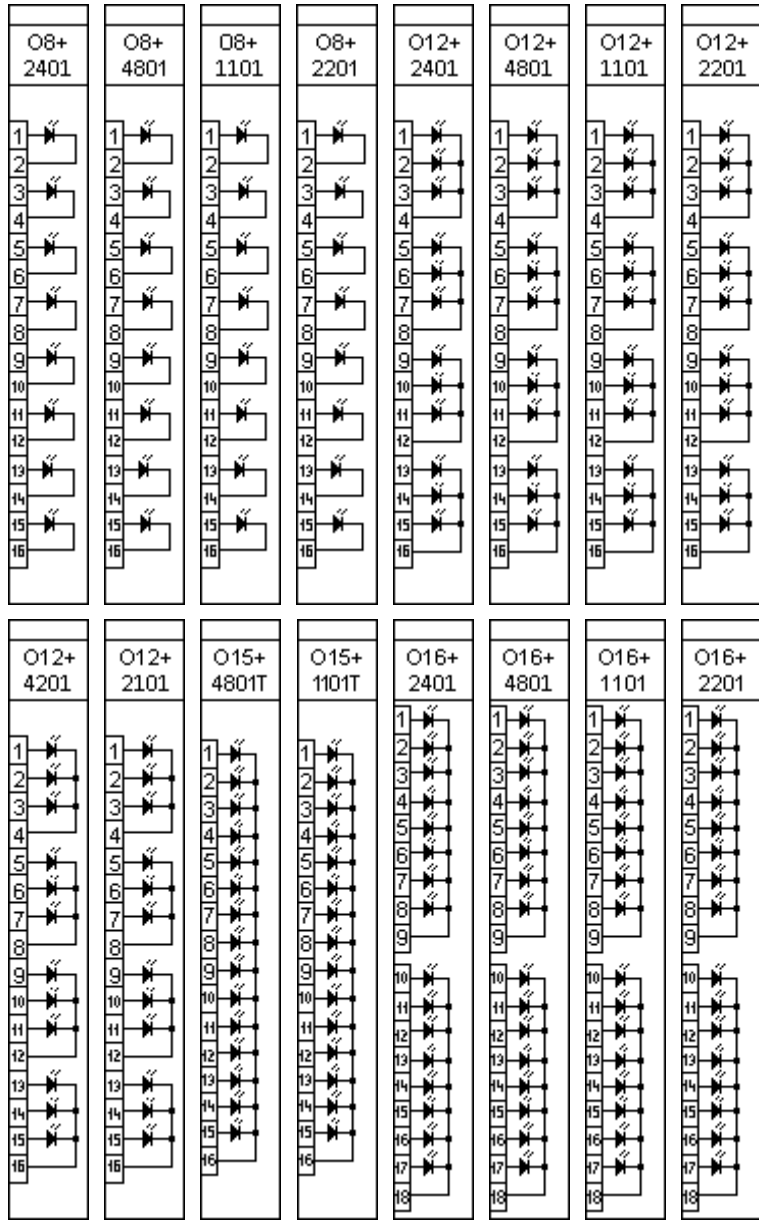
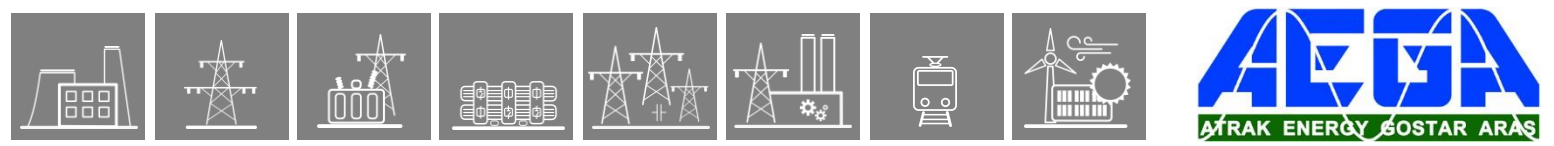

Figure 7-1 Binary input modules



1.2.8. Signaling module

The signaling module has 4, 8, 12 or 16 relay outputs with dry contacts.

Connector types:

- The default and optionally available connector types are indicated for each module in the tables below. See Chapter 20.2 for details about each type.

MODULE TYPE	R4+/01	R8+/00	R8+/80	R8+/C0
RATED VOLTAGE	250 V AC/DC	250 V AC/DC	250 V AC/DC	250 V AC/DC
CONTINUOUS CARRY	8 A	8 A	8 A	8 A
CONTACT VERSIONS	4 CO	8 NO	CH8 NC others NO	CH7 and CH8 NC others NO
GROUP ISOLATION	4 independent	8 independent	8 independent	8 independent
CONNECTOR TYPE	<u>Default:</u> BLA <u>Options:</u> F	<u>Default:</u> BLA <u>Options:</u> F, T	<u>Default:</u> BLA <u>Options:</u> T	<u>Default:</u> BLA <u>Options:</u> T

MODULE TYPE	R8+/FF	R12+/0000	R12+/4000
RATED VOLTAGE	250 V AC/DC	250 V AC/DC	250 V AC/DC
CONTINUOUS CARRY	8 A	8 A	8 A
CONTACT VERSIONS	8 NC	12 NO	CH12 NC others NO
GROUP ISOLATION	8 independent	4 × 3 common	4 × 3 common
CONNECTOR TYPE	<u>Default:</u> BLA <u>Options:</u> -	<u>Default:</u> BLA <u>Options:</u> F, T	<u>Default:</u> BLA <u>Options:</u> F, T

MODULE TYPE	R16+/0000	R16+/8000	R16+/8080
RATED VOLTAGE	250 V AC/DC	250 V AC/DC	250 V AC/DC
CONTINUOUS CARRY	8 A	8 A	8 A
CONTACT VERSIONS	16 NO	CH16 NC others NO	CH16 and CH8 NC others NO
GROUP ISOLATION	2 × 8 common	2 × 8 common	2 × 8 common
CONNECTOR TYPE	<u>Default:</u> BLA <u>Options:</u> -	<u>Default:</u> BLA <u>Options:</u> -	<u>Default:</u> BLA <u>Options:</u> -

MODULE TYPE	R4S+/01*	R4S+/16*	R1T+/0001***
RATED VOLTAGE	250 V AC/DC	250 V AC/DC	320 V AC/DC
CONTINUOUS CARRY	8 A 120 mA**	120 mA	32 A
CONTACT VERSIONS	4 CO (1 SSR, 3 normal)	4 CO (4 SSR)	1 NO
GROUP ISOLATION	4 independent	4 independent	1 independent
CONNECTOR TYPE	<u>Default:</u> BLA <u>Options:</u> -	<u>Default:</u> BLA <u>Options:</u> -	<u>Default:</u> BLA <u>Options:</u> -

*Modules with **solid-state relays (SSR)**

**If the signaling is performed via the solid-state relay the continuous carry value is 120 mA.

*****Thyristor module**. Can be used only unipolarly. For further information see our [Product availability chapter](#).

Main features (according to IEC 60255-1):

- Maximum switching voltage: 400 V AC
- Breaking capacity: (L/R=40 ms) at 220 V DC: 0.2 A, at 110 V DC: 0.3 A
- Breaking capacity max.: 2000 VA
- Short time carrying capacity: 1 s, 35 A
- Limiting making current, max. 4 s: 15 A (df = 10 %)
- Dielectric strength between open contacts, 1 min: 1000 V_{RMS}
- Mechanical endurance: 10 × 10⁶ cycles
- Circuit closing capability: typically 10 ms, maximally 22 ms, with SSR 0.5 ms.
- Bounce time: typically 6,5 ms, maximally 10 ms, with SSR 0.5 ms.
- Minimal switching requirement: 5 V
- *The signaling is also performed via a solid-state relay (SSR) channel on R4S+01 and R4S+16 module*

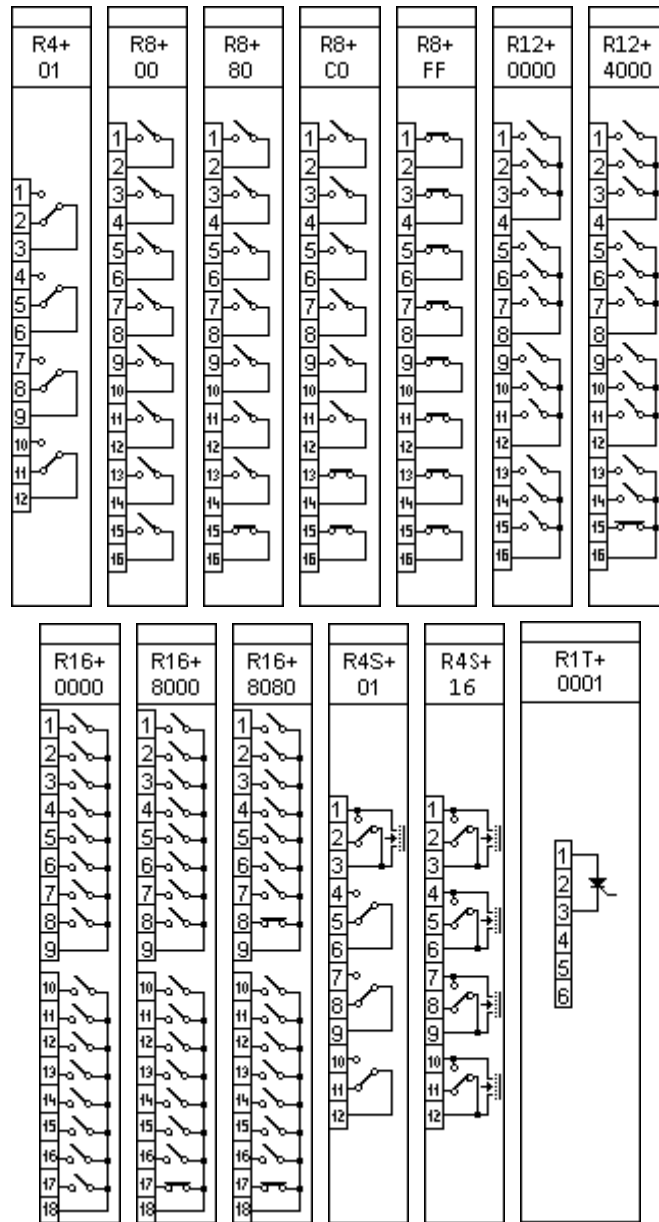

Figure 8-1 Signaling modules

1.2.9. Tripping module

The tripping module is a proprietary and patented solution that facilitates direct control of a circuit breaker.

Connector types:

- The default and optionally available connector types are indicated for each module in the table below. See Chapter 20.2 for details about each type.

MODULE TYPE	TRIP+/4201	TRIP+1101*	TRIP+/2101	TRIP+/21F1**	TRIP+/2201
CHANNEL NUMBER	4	4	4	4	4
RATED VOLTAGE	24 V DC and 48 V DC	110 V DC	110 V DC	110 V DC	220 V DC
THERMAL WITHSTAND VOLTAGE	72 V DC	242 V DC	150 V DC	150 V DC	242 V DC
CONTINUOUS CARRY	8 A	8 A	8 A	8 A	8 A
MAKING CAPACITY	0.5 s, 30 A	0.5 s, 30 A	0.5 s, 30 A	0.5 s, 30 A	0.5 s, 30 A
BREAKING CAPACITY	L/R = 40 ms: 4 A DC	L/R = 40 ms: 4 A DC	L/R = 40 ms: 4 A DC	L/R = 40 ms: 4 A DC	L/R = 40 ms: 4 A DC
CONNECTOR TYPE	<u>Default:</u> BLA <u>Options:</u> F, T	<u>Default:</u> BLA <u>Options:</u> -	<u>Default:</u> BLA <u>Options:</u> F, T	<u>Default:</u> BLA <u>Options:</u> T	<u>Default:</u> BLA <u>Options:</u> T

***Obsolete module. These modules are not recommended for new designs!**

****Without trip circuit supervision.**

Main features:

- High-speed operation: with pre-trip 0.5 ms, without pre-trip typically 10 ms, maximally 22 ms.
- Trip circuit supervision for each trip contact, except TRIP+21F1
- With 2-wire wiring, the tripping output can be *dry* contact type, too

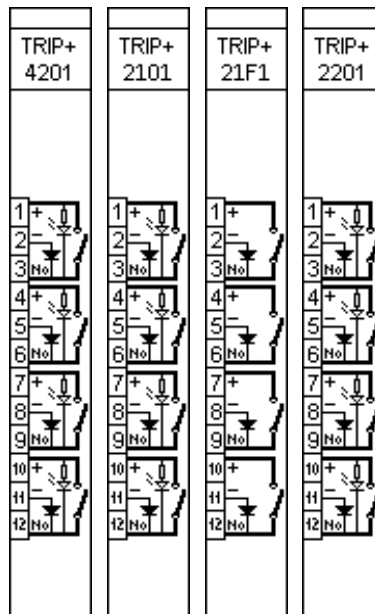

Figure 9-1 Tripping modules

1.2.9.1. TRIP+ module wiring

The tripping module provides tripping circuit supervision function (TCS). The wiring of these modules can be 2-wire or 3-wire. (TCS function is active for all wiring methods.)

The voltage of the "No" contact is maximized at 15 V by a Zener-diode. Make sure that the voltage caused by the resistance of the circuit breaker and the injected current from the TRIP+ module does not reach 10 V.

Our TRIP+ modules are improved to switch DC circuits. **Using reversed polarity or AC voltage can cause the damage of the internal circuits. Improper wiring might cause improper operation!**

1.2.9.1.1. 3-wire TRIP+ wiring methods

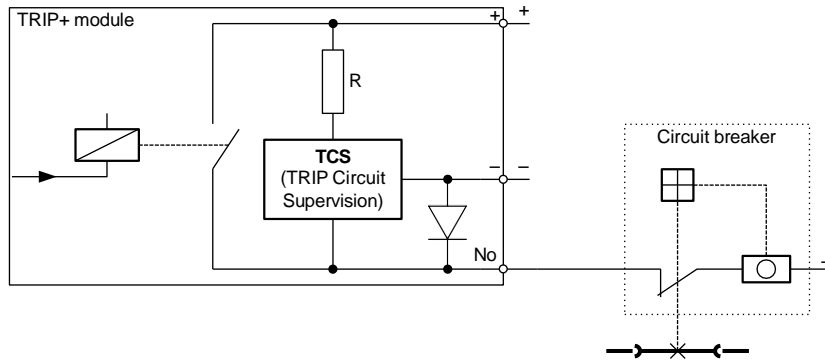

Figure 9-2 3-wire TRIP+ wiring

It is possible to use parallel connected TRIP+ modules. In this case the negative terminals must be common.

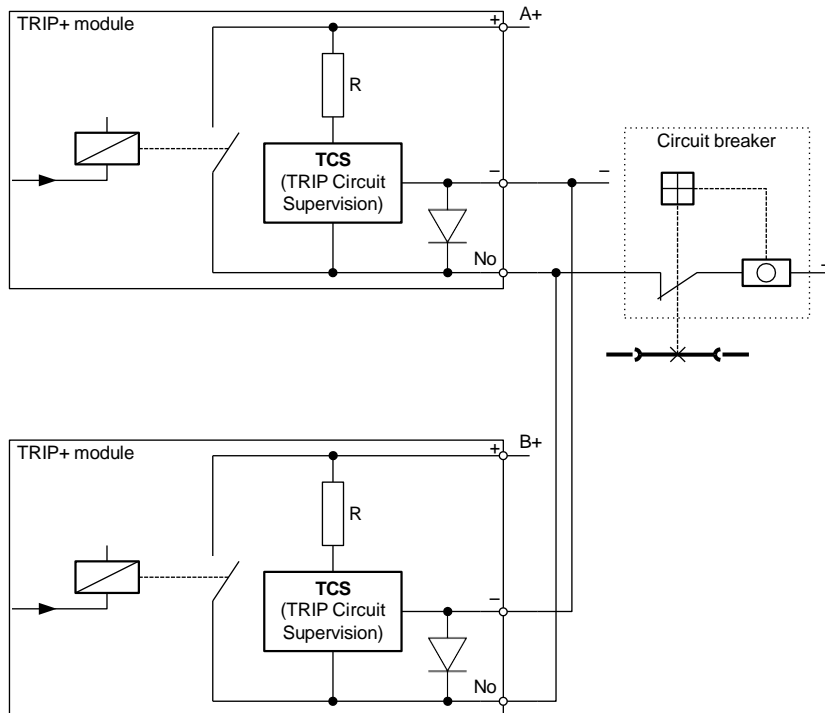

Figure 9-3 3-wire TRIP+ wiring using parallel connected TRIP+ modules

1.2.9.1.2. 2-wire TRIP+ wiring methods

If necessary, the TRIP+ modules can be wired using only the “+” and the “No” contacts.

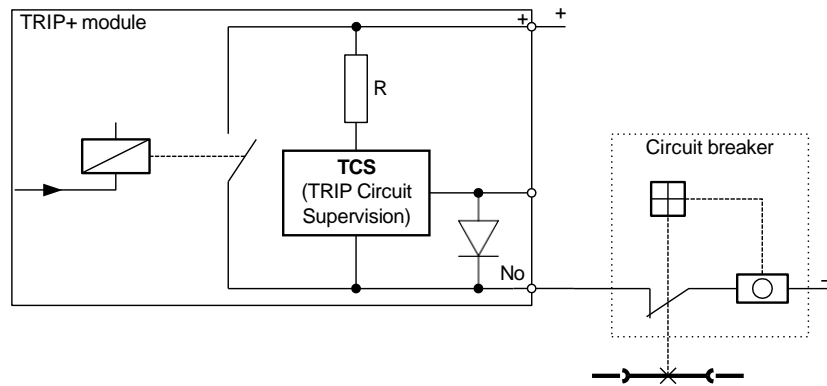

Figure 9-4 2-wire TRIP+ wiring

It is possible to use parallel connected TRIP+ modules.

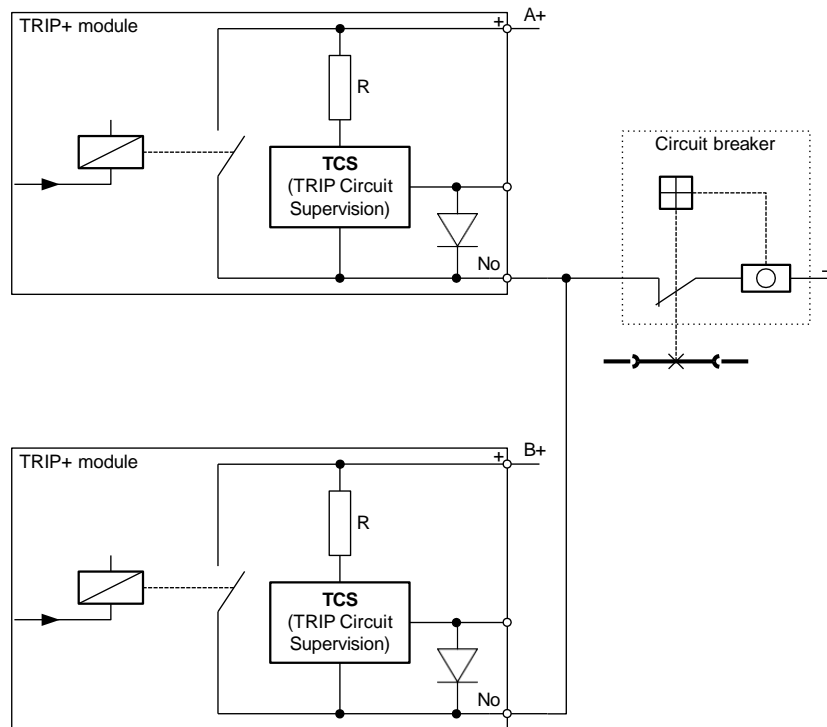

Figure 9-5 2-wire TRIP+ wiring using parallel connected TRIP+ modules

If the circuit breaker needs two-pole switching TRIP+ modules can be connected series as you can see in Figure 9–6.

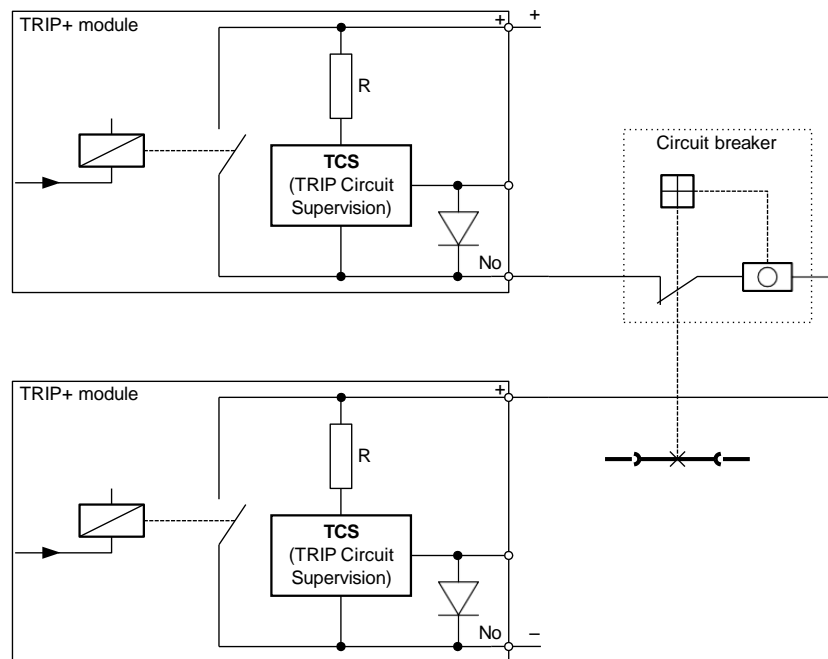

Figure 9-6 2-wire TRIP+ wiring using series connected TRIP+ modules

1.2.9.2. Trip Circuit Supervision (TCS)

Apart from the TRIP+/21F1, all TRIP modules have TCS. The feature is described in detail (tech. data, instructions, etc.) in a separate document:

https://www.protecta.hu/downloads/tcs_en

The technical data of the TCS is shown here as well:

MODULE TYPE	TRIP+/4201	TRIP+/2101	TRIP+/2201	
VALUE OF R RESISTOR (± 10 %)	10 kΩ	73 kΩ	130 kΩ	
INJECTED CURRENT AT "NO" CONTACT	2.4 mA @ 24 V DC 4.8 mA @ 48 V DC	1.5 mA @ 110 V DC	1.7 mA @ 220 V DC	
MAXIMUM RESISTANCE OF THE TRIP COIL	3-WIRE WIRING (MAX. 10 V)	11.8 kΩ @ 24 V DC 3.7 kΩ @ 48 V DC	9.7 kΩ @ 110 V DC 8.4 kΩ @ 125 V DC	8.1 kΩ @ 220 V DC
	3-WIRE WIRING WITH IN PARALLEL (MAX. 10 V)	5.9 kΩ @ 24 V DC 1.8 kΩ @ 48 V DC	4.8 kΩ @ 110 V DC 4.2 kΩ @ 125 V DC	4 kΩ @ 220 V DC
	2-WIRE METHOD (1 mA MIN. CURRENT)	14 kΩ @ 24 V DC 38 kΩ @ 48 V DC	37 kΩ @ 110 V DC 52 kΩ @ 125 V DC	90 kΩ @ 220 V DC

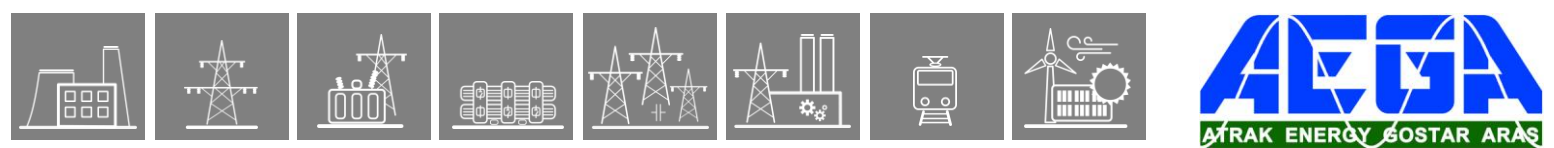

1.2.9.3. Relay output modules of the EuroProt+ system

1.2.9.3.1. Types of the relay output modules of the EuroProt+ system

Basically there are two different types of relay output modules in the EuroProt+ devices: TRIP relay output module for high-speed operation of the circuit breakers Signal relay output module

1.2.9.3.2. Operating modes of the relay contacts

For operation of the relay output modules there are four different modes:

Application of TRIP relays for commands of fast protection functions

User application of the TRIP relays Fast operation of any relay contacts (TRIP relays or signal relays) Control of signal relay outputs.

The procedures of command processing are shown in. This document describes the details using the TRIP relay contacts as an example.

The left side of the Figure shows the available sources of the trip commands:

The functionblocks, configured in the device,

The communication channels to the SCADA system,

Commands generated using the front panel LCD of the device,

Any other binary signals, e.g. signals from the binary inputs of the device.

The right side of the Figure shows one of the TRIP relays symbolically.

The Figure provides a survey of the configured trip command processing methods. In the middle of the Figure, the locations indicated by "User" shows the possibilities for the user to modify the procedures. All other parts are factory programmed.

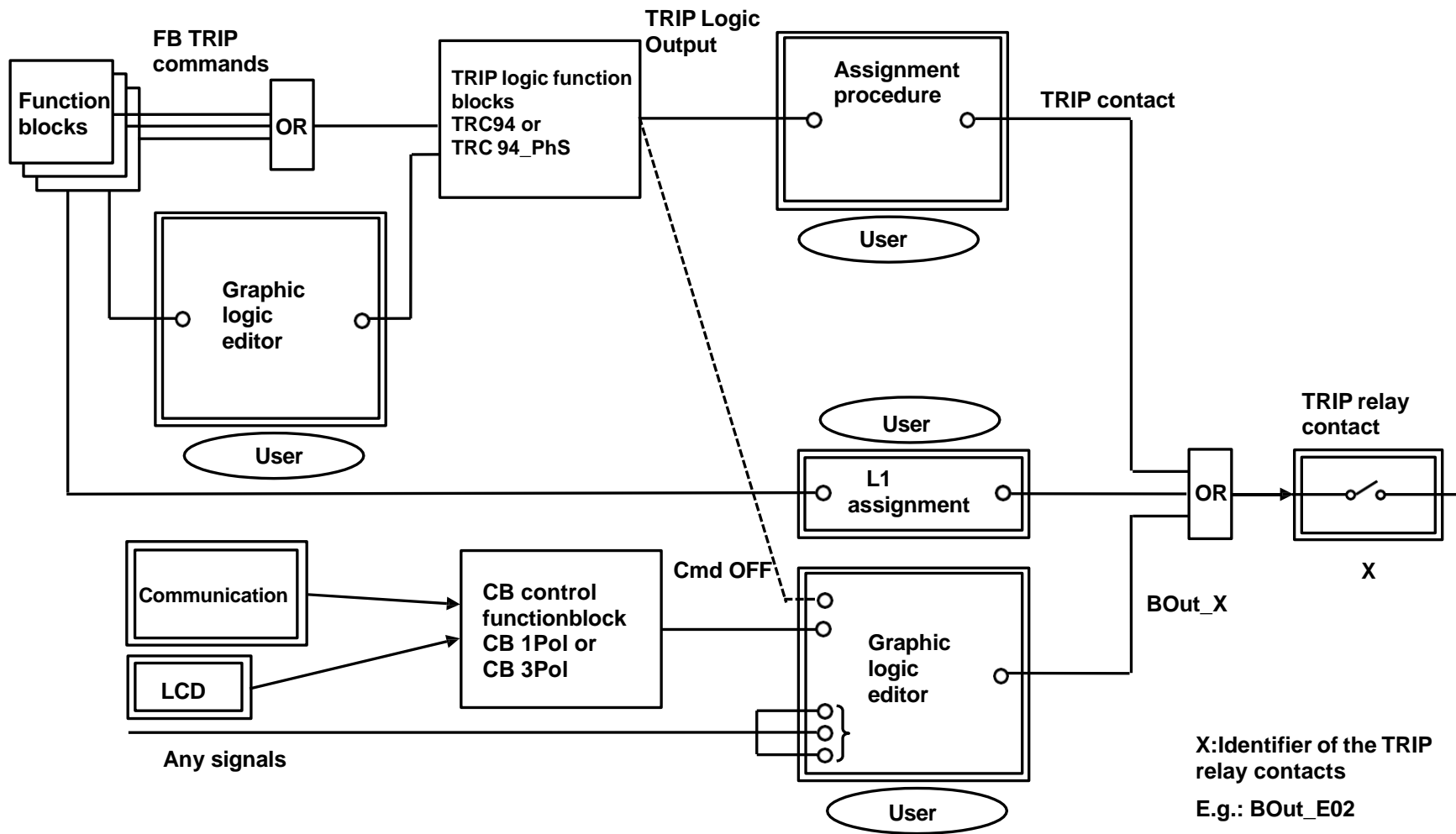

Figure 1-1 Principle of TRIP command processing



1.2.9.3.3. Application of TRIP relays for commands of fast protection functions

1.2.9.3.3.1. Aim of application of TRIP relays

The main aim of application of TRIP relays is to bypass the time delay of the mechanical contacts. For this aim there is a „slow” mechanical contact and a „fast” electronic switch in serial connection.

1.2.9.3.3.2. Control of the TRIP relays

The operation of the TRIP relays is performed in two steps:
Preparation of the circuit for the trip command
Trip command generation

1.2.9.3.3.2.1. Preparation of the circuit for the trip command

At the time when a protection function detects violation of the setting value of the characteristic quantity, the preparation process closes the „slow” mechanical contact, preparing the circuit for command generation.

1.2.9.3.3.2.2. The trip command generation

At the moment when the fast protection function – after some repeated checks, i.e. the timeout of the internal time counter – decides to generate the trip command then the „fast” electronic switch performs the operation, generating the trip command to the circuit breaker. This command is generated via the „TRC94_ PhS” or via the simplified „TRC94” trip logic functionblocks.

NOTE: If the TRIP command is not received within the expected time delay, then the command preparation resets after 50 ms. When the device is tested in the laboratory e.g. for measuring the limits of the distance protection characteristic, this can result a cyclic closing and opening of the mechanical contact and rattling can be heard. This does not mean faulty operation of the device!

1.2.9.3.3.3. The factory programming for relay control

For the trip command of protection functions, where the requirement is the fast operation (distance protection first zone, line differential protection, transformer differential protection, fast overcurrent stage, synchronous switching, etc.) the process of preparation and command generation is programmed in the form of „Fast logic”.

The alignment of the TRIP command is the task of the “TRIP logic functionblock”. All devices operating with TRIP binary output module, has a configured TRC 94 simplified, or a TRC 94_PhS TRIP logic functionblock. This converts e.g. the trip command due to phase-to-phase fault to a three-phase trip command, or extends the duration of the command according to the parameter setting. All these are described in the dedicated document.

The fast TRIP commands are assigned to the TRIP relay output contacts according to the factory configuration, but the user has a possibility to modify or extend this assignment using the EuroCAP configuration software. The factory assignment is described in the user manual of the given device configuration.

To ensure fast operation, this „Fast logic” is performed in each sampling cycle (1ms).

1.2.9.3.3.4. Changing the TRIP command assignment

The user has a possibility to modify or extend the TRIP command assignment using the EuroCAP configuration software. The menu item to be started is shown in *Figure 2-1*.

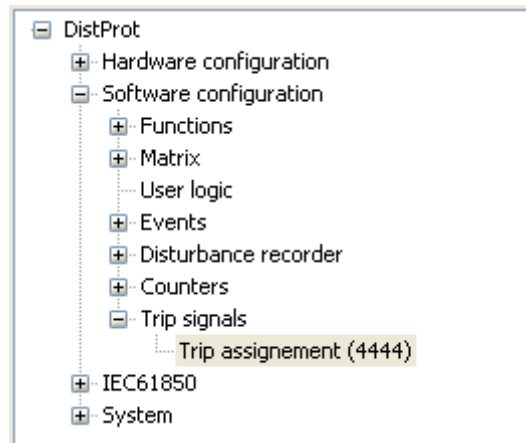

Figure 2-1 Menu item for TRIP command assignment

As *Figure 2-2* shows, the signal of type „TripLogic Output” (this is the command generated by the „TRIP logic functionblock”) can be assigned to a „Trip Contact” type relay output. The dialog window of the EuroCAP software selects these types of signals only; the available signals however can be assigned freely.

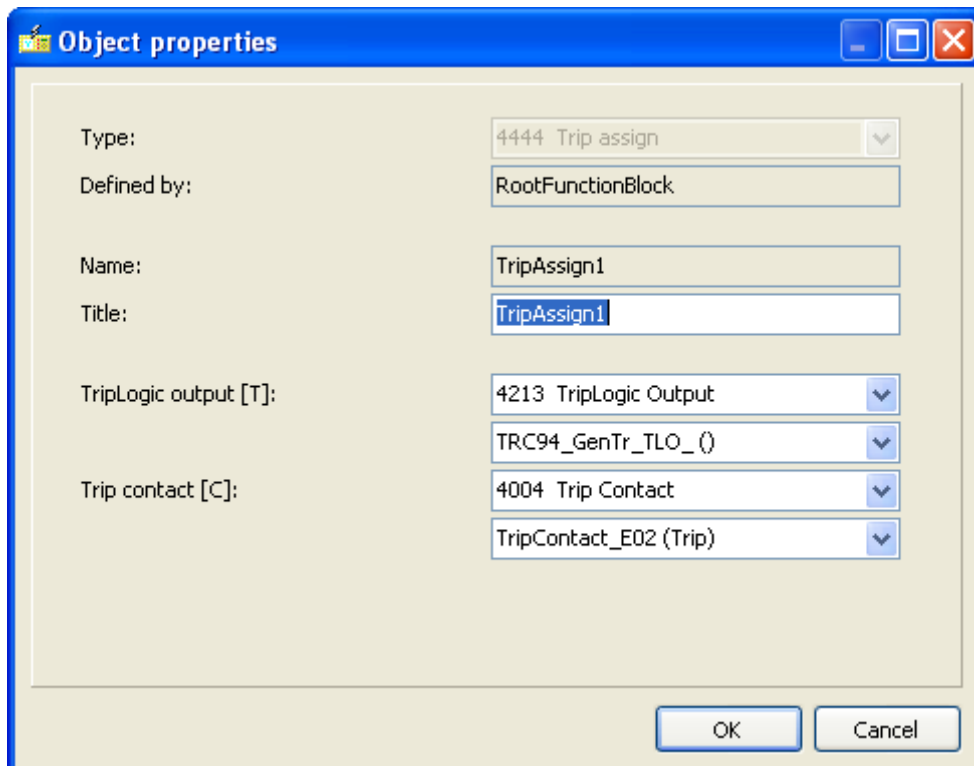

Figure 2-2 Changing the TRIP command assignment

The assigned signal is the input of an OR gate. As it is described below, several other signals can be directed to this OR gate. Using this method, also other TRIP modules extended by the user can be applied to operate the TRIP coil of the circuit breaker.

1.2.9.3.3.5. Fast operation of the relays

If the aim is to operate the contacts by a signal in each sampling cycle (1 ms), then the “Fast L1 contact option is to be applied. This option is provided by the EuroCAP configuration software in the menu „Hardware configuration/ IO signals/ Binary outputs/ Relay contacts/ Fast_L1 contacts”.

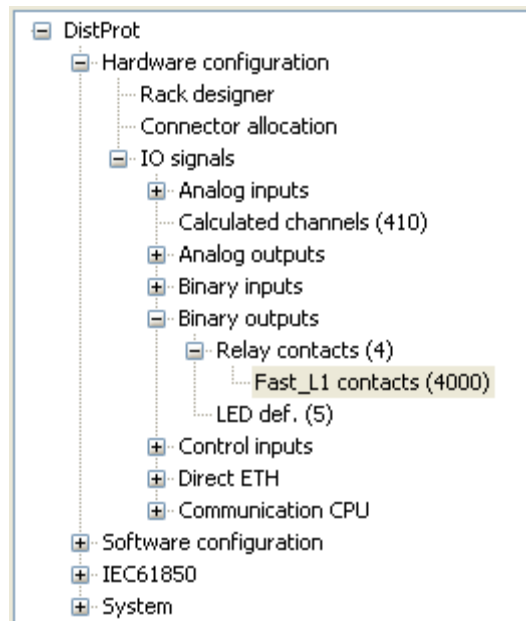

Figure 2-3 Configuring Fast L1 contacts

This menu offers the assignment of the appropriate binary signals to the relay contacts. As Figure 2-4 shows, the signal can be of several types.

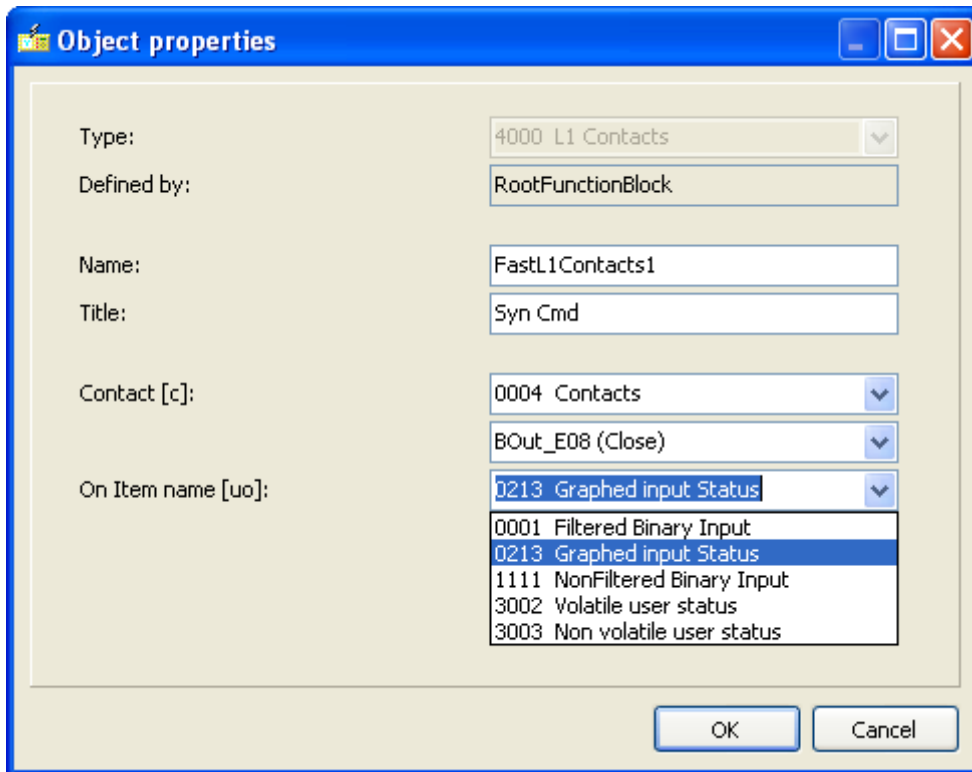

Figure 2-4 Fast L1 contact assignment

The processing of these fast signals is performed in a single step, the possibility for command preparation in the first step and additionally the TRIP command generation in the second step is not offered for the user. To perform this assignment, the application of the EuroCap configuration program in “Master” level is needed.

The selected signal is the input of an OR gate. To this gate additional other signals are connected, as it is described in the previous chapter, or in the description below.

IMPORTANT NOTE: The contacts of a TRIP hardware module are configured in the factory as “Fast L1 contacts”, the user does not need to define them additionally!

1.2.9.3.4. User application of the TRIP relays

The contacts controlling the circuit breaker operation can be programmed also by the user. Additionally to the command of the factory configured protection functions the user can assign signals to the channels of the TRIP hardware module. The two steps for the command generation however, as it is described in the paragraph above, cannot be applied by the user.

In this case, the source of the signals can be:

- Pre-configured TRIP commands
 - Received from the SCADA system via communication channels,
 - Generated by the user, applying the front panel LCD of the device,
- Any additional binary signals, e.g. an external command received by the binary input module of the device.

The pre-configured TRIP commands are aligned by the “CB control functionblock”, the output of which is the “CmdOff” TRIP command. This one and several other



signals can be programmed by the user to the output TRIP contact of the device, using the graphic logic editor of the EuroCAP configuration software.

Additionally the output signals of the „TRC94_PhS” trip logic or those of the „TRC94” simplified trip logic block can be programmed here. (These function-blocks are described in separate documents.) The output signal of the graphic logic editor is the „BOut_X” logic variable, where X is the identifier of the relay module and the contact, e.g. BOut_E02.

1.2.9.3.4.1. Graphic editor for the signal logic

For the protection functions, the operation of which are not required being extreme fast (in the range of one network period), the trip command must be assigned to the trip contacts usually by the user. These logic assignments can be programmed also in the factory, but the user can modify or extend them according to the requirements. To do this, the graphic editor of the EuroCap configuration tool must be applied with „Master” access rights.

1.2.9.3.4.2. The process of command generation

If a “simple” protection function generates a trip command then this logic signal is present on the dedicated output of the functionblock (see the description of the functionblocks).

The operation of the logic connections edited in the graphic editor is performed outside the sampling cycle, consequently, depending on the actual load of the processor a random time delay of additional 2-4 ms can be measured.

The contacts of the TRIP hardware modules are operated by several sources parallel:

The high-speed factory configured fast protection functions,
The defined Fast L1 signals,
The graphically edited logic connections (programmed in the factory and editable also by the user).

1.2.9.3.5. Control of signal relay outputs

If there is no special requirement to generate the signal with high speed, i.e. a time delay of 2-4 ms can be tolerated between the intent to generate the signal and the closing of the output contact then it is sufficient to apply normal signal relay contacts. To perform this programming the graphic editor of the EuroCap configuration tool is to be applied. To perform the programming the „Master” access level is needed.

1.2.9.4. Examples

1.2.9.4.1. Application of the TRIP logic

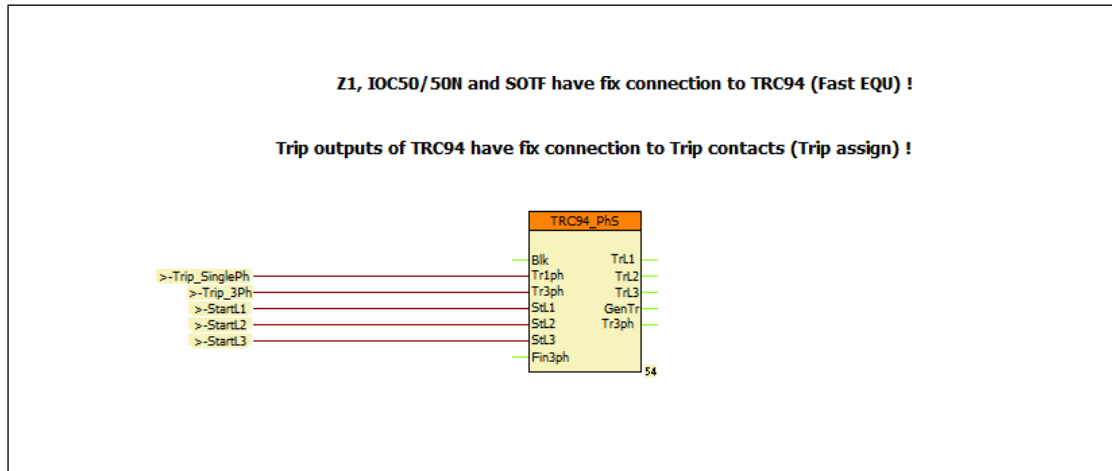

Figure 5-1 Example: A simple configuration to trip the circuit breaker

Figure 5-1 shows a simple configuration to trip the circuit breaker. In this Figure it is supposed that the fast protection functions operate according to the factory configuration and they control the TRIP contacts applying two steps of the preparation and command generation phases. This part of the program is not visible. (The description of the fast operating protection functions are listed in the configuration description of the devices.)

The outputs of the TRC94_PhS trip logic block are assigned to the channels of the TRIP hardware module. This assignment, which can be modified also by the user, is made not here but in the “TRIP assignment” menu of the EuroCAP configuration software. Consequently the Figure is complete; related to the outputs, the user needs additional graphic programming only if e.g. the operation is to be visualized also by signal relays.

If the configuration includes protection functions blocks the trip command of which does not need fast contact operation then these commands must be additionally directed to the TRIP relay outputs. To do this, the user collects these commands (with OR connection) and connects them to the dedicated inputs of the TRC94_PhS functionblock.

This Figure shows the collected signals (E.g. “Trip_SinglePh”, “Trip_3Ph”, etc.) only. As an example the „Trip_3Ph” signal collects the commands of all (not fast operating) protection functions which can generate three-phase trip command. The detailed description of the inputs and operation of the “TRC94_PhS” trip logic functionblock can be found in another document.

1.2.9.4.2. Application of circuit breaker control block

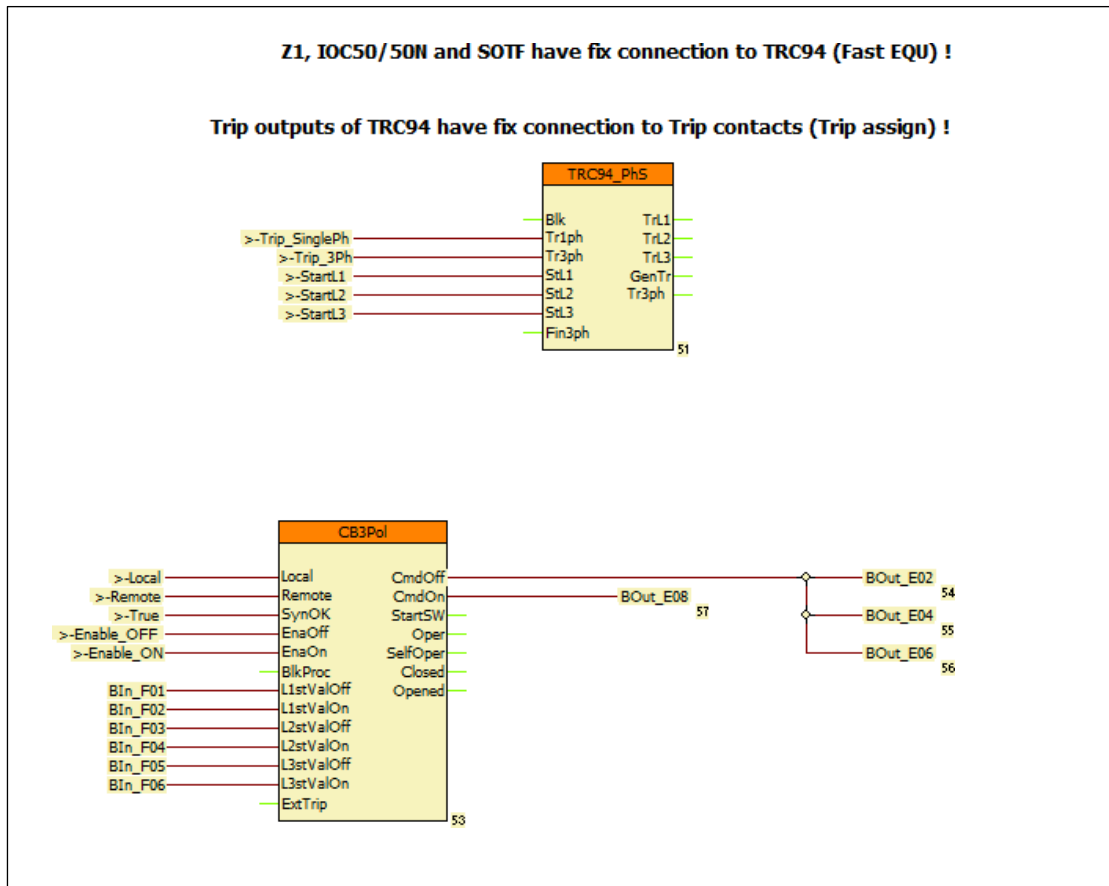

Figure 5-2 Example: Application of circuit breaker control block

Figure 5-2 shows an example for the application of the circuit breaker control block “CB3Pol”. In this Figure it is supposed that the fast protection functions operate according to the factory configuration and they control the TRIP contacts applying two steps of the preparation and command generation phases. This part of the program is not visible. (The description of the fast operating protection functions are listed in the configuration description of the devices.)

The outputs of the TRC94_PhS trip logic block are assigned to the channels of the TRIP hardware module. This assignment, which can be modified also by the user, is made not here but in the “TRIP assignment” menu of the EuroCAP configuration software. Consequently the Figure is complete; related to the outputs, the user needs additional graphic programming only if e.g. the operation is to be visualized also by signal relays.

If the configuration includes protection functions blocks the trip command of which does not need fast contact operation then these commands must be additionally connected to the TRIP relay outputs. To do this, the user collects these commands (with OR connection) and assigns them to the dedicated inputs of the TRC94_PhS functionblock.

This Figure shows the collected signals (E.g. “Trip_SinglePh”, “Trip_3Ph”, etc.) only. As an example the „Trip_3ph” signal collects the commands of all (not fast operating) protection functions which can generate three-phase trip command. The detailed description of the inputs and operation of the “TRC94_PhS” trip logic functionblock can be found in another document.

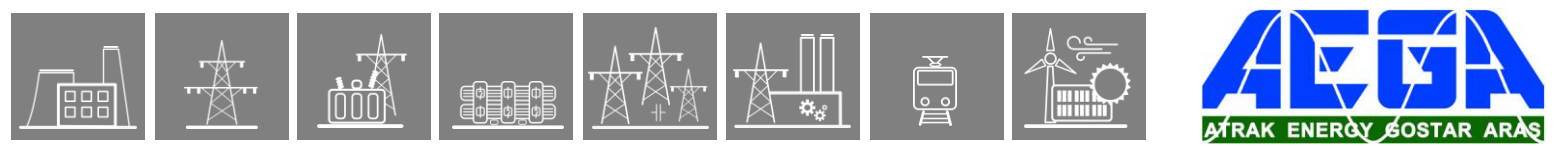

An extension to the example in *Figure 5-2* is that in this configuration also the „CB3pol” (circuit breaker control block) is applied. This block is needed if e.g. the front panel LCD of the device can display an active control scheme. For this purpose the signals „BIn_F...” in the Figure are the status signals of the circuit breaker poles, connected to the dedicated binary inputs of the device. The signals „Local”/”Remote” enable the local or remote control of the primary equipment. In the standard factory configurations these signals are programmed in the factory, but they can be modified also by the user.

If there is no synchro-check function activated in the device, connect the input „SynOK” of the “CB3Pol” to logic TRUE state. *Figure 5-2*, the local command issued via LCD of the device or the remote command received from the remote SCADA system is processed by the „CB3pol” functionblock (Output „CmdOff”). This control is programmed in the factory to “BOut_xx” variables. The user can perform any modification in the graphic programming.

The close command is connected directly to a dedicated “BOut_xx” variable. (This directs usually the fourth contact of the TRIP hardware module.)

The programming of the interlocking function must be performed by the user.

1.2.9.4.3. Automatic reclosing and circuit breaker control

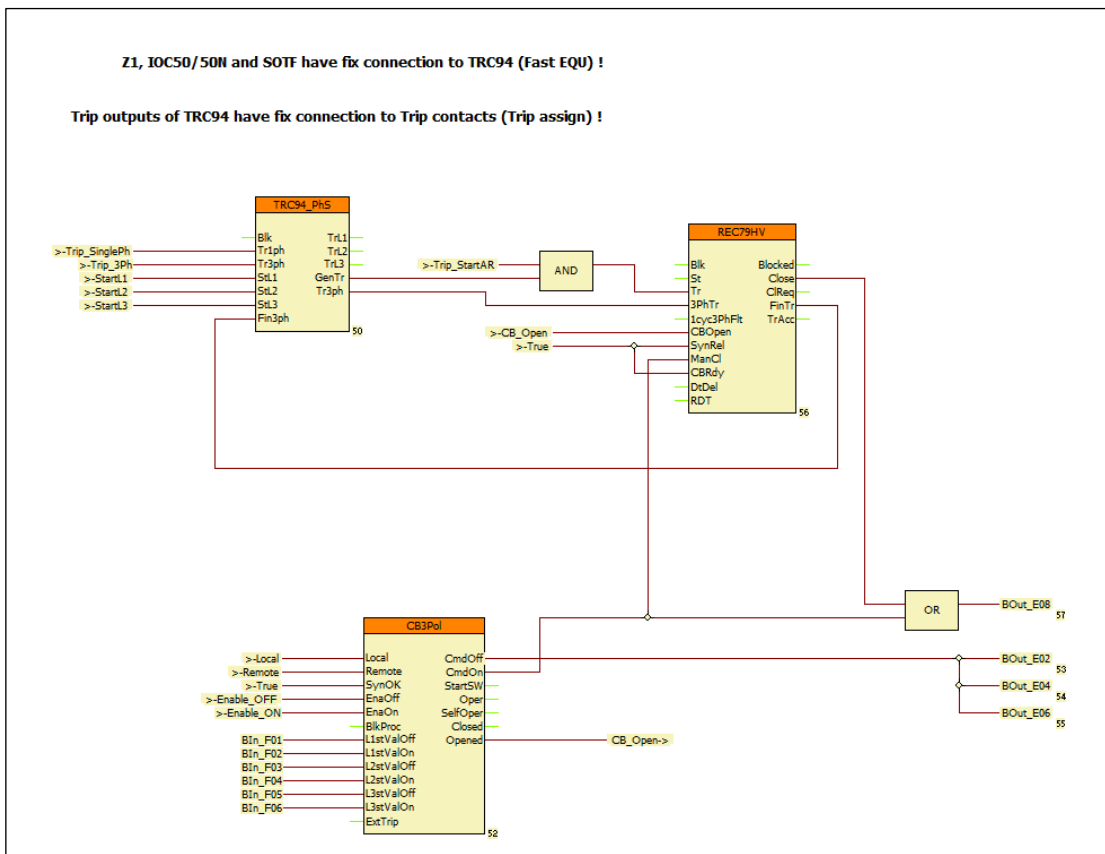

Figure 5-3 Example: Automatic reclosing and circuit breaker control

Figure 5-3 shows an example for the application of the automatic reclosing control block. In this Figure it is supposed that the fast protection functions operate according to the factory configuration and they control the TRIP contacts applying two steps of the preparation and command generation phases. This part of the program is not visible in “Master” level. (The description of the fast operating protection functions are listed in the configuration description of the devices.)

The outputs of the TRC94_PhS trip logic block are assigned to the output channels of the TRIP hardware module. This assignment, which can be modified also by the user, is made not here but in the “TRIP assignment” menu of the EuroCAP configuration software. Consequently the Figure is complete; related to the outputs, the user needs additional graphic programming only if e.g. the operation is to be visualized also by signal relays.

If the configuration includes protection functions blocks the trip command of which does not need fast contact operation then these commands must be additionally assigned to the TRIP relay outputs. To do this, the user collects these commands (with OR connection) and assigns them to the dedicated inputs of the TRC94_PhS functionblock.

This Figure shows the collected signals (E.g. “Trip_SinglePh”, “Trip_3Ph”, etc.) only. As an example the „Trip_3ph” signal collects the commands of all (not fast operating) protection functions which can generate three-phase trip command. The detailed description of the inputs and operation of the “TRC94_PhS” trip logic functionblock can be found in another document.



In this configuration also the „CB3pol” (circuit breaker control block) is applied. This block is needed if e.g. the front panel LCD of the device can display an active control scheme. For this purpose the signals „BIn_F...” in the Figure are the status signals of the circuit breaker poles, connected to the dedicated binary inputs of the device. The signals „Local”/”Remote” enable the local or remote control of the primary equipment. In the standard factory configurations these signals are programmed in the factory, but they can be modified also by the user.

If there is no synchro-check function activated in the device, connects the input „SynOK” of the “CB3Pol” to logic TRUE state.

According to *Figure 5-3*, the local command issued via LCD of the device or the remote command received from the remote SCADA system is processed by the „CB3pol” functionblock (Output „CmdOff”). This control is programmed in the factory to “BOut_xx” variables. The user can perform any modification in the graphic programming.

The close command is connected directly to a dedicated “BOut_xx” variable. (This directs usually the fourth contact of the TRIP hardware module.)

In *Figure 5-3* the close command is connected directly to a dedicated output. (This is usually the fourth contact of the TRIP hardware module.)

The programming of the interlocking function must be performed by the user.

An extension to the example in *Figure 5-2* is the application of the „REC79_HV” automatic reclosing function. The start signal „Trip_StartAR” can be programmed by the user. The automatic reclosing function is started only if the preceding trip command was performed by the circuit breaker, i.e. for example that the function is not disabled. The AND gate on this Figure performs this checking.

The „REC79_HV” automatic reclosing function needs the status signal indicating three-phase open state of the circuit breaker, connected to the „3PhTr” input of the „REC79_HV” functionblock. This signal is generated by the „TRC94_PhS” functionblock on the output „Tr3Ph”.

If the automatic reclosing is to be disabled after a fault caused by a manual close command, then the „CmdOn” output of the „CB3Pol” module must be connected to the „ManCl” input of the „REC79_HV” automatic reclosing function.

If there is no synchro-check function configured in the device, connect the „SynRel” input of the „REC79_HV” automatic reclosing function to logic TRUE state.

The evaluation of the status signals indicating the open state of the circuit breaker poles in OR gate is needed for the operation of the automatic reclosing function. According to the scheme of *Figure 5-3* the open state is indicated by at least one pole open state of the circuit breaker. (For simplicity, this Figure shows a realization without checking the FALSE signal of the closed states.)

Figure 5-3 supposes that the CB ready signal is not connected to the device; accordingly the steady TRUE state signal is connected to the „CBRdy” input of the „REC79_HV” automatic reclosing function. If the real signal is available, the signal must be connected similarly.

The close command of the „REC79_HV” automatic reclosing function is connected via OR gate to the dedicated close contact.

1.2.9.4.4. Closing the circuit breaker with synchro-check

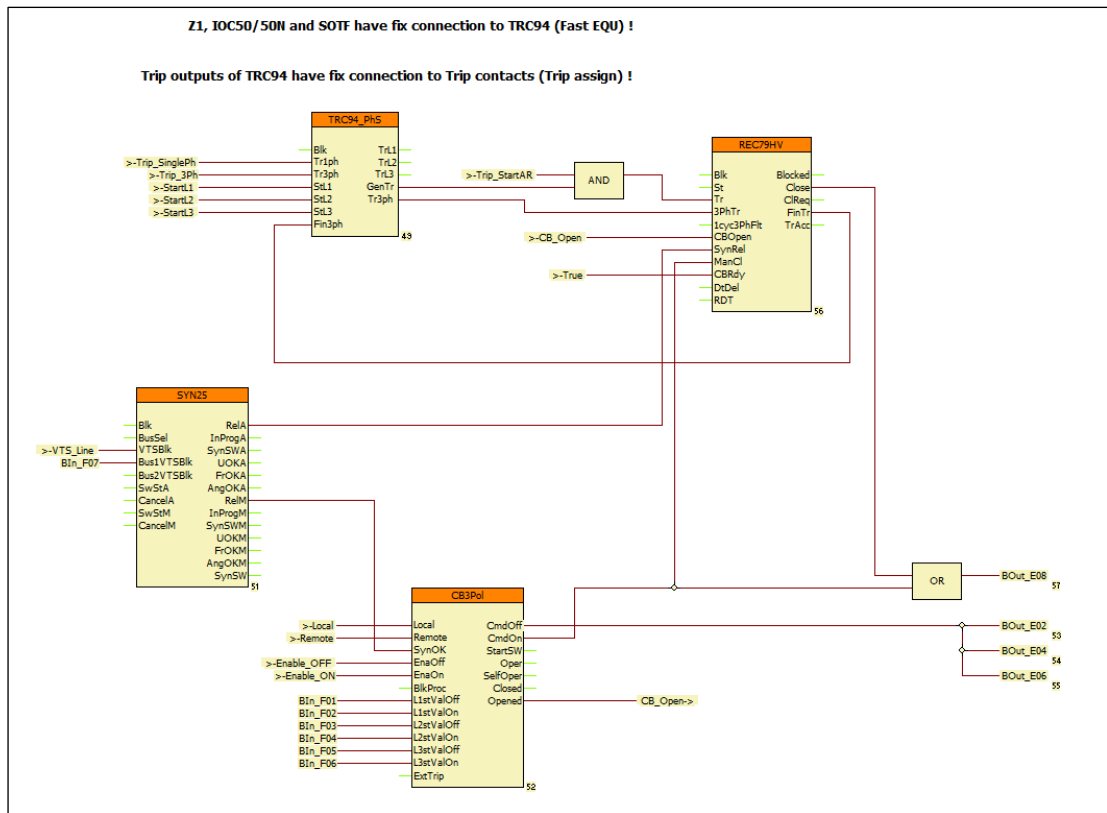

Figure 5-4 Example: closing the circuit breaker with synchro-check

Figure 5-4 shows an example for the application of “SYN25” synchro-check functionblock. In this Figure it is supposed that the fast protection functions operate according to the factory configuration and they control the TRIP contacts applying two steps in “Master” level. (The description of the fast operating protection functions are listed in the configuration description of the devices.)

The outputs of the TRC94_PhS trip logic block are assigned to the output channels of the TRIP hardware module. This assignment, which can be modified also by the user, is made not here but in the “TRIP assignment” menu of the EuroCAP configuration software. Consequently the Figure is complete; related to the outputs, the user needs additional graphic programming only if e.g. the operation is to be visualized also by signal relays.

If the configuration includes protection functions blocks the trip command of which does not need fast contact operation then these commands must be additionally assigned to the TRIP relay outputs. To do this, the user collects these commands (with OR connection) and assigns them to the dedicated inputs of the TRC94_PhS functionblock.

This Figure shows the collected signals (E.g. “Trip_SinglePh”, “Trip_3Ph”, etc.) only. As an example the „Trip_3ph” signal collects the commands of all (not fast operating) protection functions which can generate three-phase trip command. The detailed description of the inputs and operation of the “TRC94_PhS” trip logic functionblock can be found in another document.



In this configuration also the „CB3pol” (circuit breaker control block) is applied. This block is needed if e.g. the front panel LCD of the device can display an active control scheme. For this purpose the signals „Bln_F...” in the Figure are the status signals of the circuit breaker poles, connected to the dedicated binary inputs of the device. The signals „Local”/„Remote” enable the local or remote control of the primary equipment. In the standard factory configurations these signals are programmed in the factory, but they can be modified also by the user.

According to *Figure 5-4*, the local command issued via LCD of the device or the remote command received from the remote SCADA system is processed by the „CB3pol” functionblock (Output „CmdOff”). This control is programmed in the factory to “BOut_xx” variables. The user can perform any modification in the graphic programming.

The close command is connected directly to a dedicated “BOut_xx” variable. (This directs usually the fourth contact of the TRIP hardware module.)

In *Figure 5-4* the close command is connected directly to a dedicated output. (This is usually the fourth contact of the TRIP hardware module.)

The programming of the interlocking function must be performed by the user.

Figure 5-4 includes the application of the „REC79_HV” automatic reclosing function. The start signal „Trip_StartAR” can be programmed by the user. The automatic reclosing function is started only if the preceding trip command was performed by the circuit breaker, i.e. for example that the function is not disabled. The AND gate on this Figure performs this checking.

The „REC79_HV” automatic reclosing function needs the status signal indicating three-phase open state of the circuit breaker, connected to the „3PhTr” input of the „REC79_HV” functionblock. This signal is generated by the „TRC94_PhS” functionblock on the output „Tr3Ph”.

If the automatic reclosing is to be disabled after a fault caused by a manual close command, then the „CmdOn” output of the „CB3Pol” module must be connected to the „ManCl” input of the „REC79_HV” automatic reclosing function.

The evaluation of the status signals indicating the open state of the circuit breaker poles in OR gate is needed for the operation of the automatic reclosing function. According to the scheme of *Figure 5-4* the open state is indicated by at least one pole open state of the circuit breaker. (For simplicity, this Figure shows a realization without checking the FALSE signal of the closed states.)

Figure 5-4 supposes that the CB ready signal is not connected to the device; accordingly the steady TRUE state signal is connected to the „CBRdy” input of the „REC79_HV” automatic reclosing function. If the real signal is available, the signal must be connected similarly.

The close command of the „REC79_HV” automatic reclosing function is connected via OR gate to the dedicated close contact.

An extension to the example in *Figure 5-3* is the close command to the circuit breaker is generated by synchro-check. The enabling signal for the close command is generated by the „SYN25” software module. This module is described in details in a separate document. The needed input signals indicating the state of the voltage transformers („VTSBik” and „Bus1VTSBik”), must be programmed graphically.

The output signal „RelA” of the „SYN25” software module enables the closing operation of the „REC79_HV” automatic reclosing function via its „SynRel” input.

For manual close commands the output signal „ReIM” of the „SYN25” software module enables the closing operation of the „CB3pol” via its „SynOK” input.

1.2.9.4.5. Closing the circuit breaker with synchro-check and synchro-switch

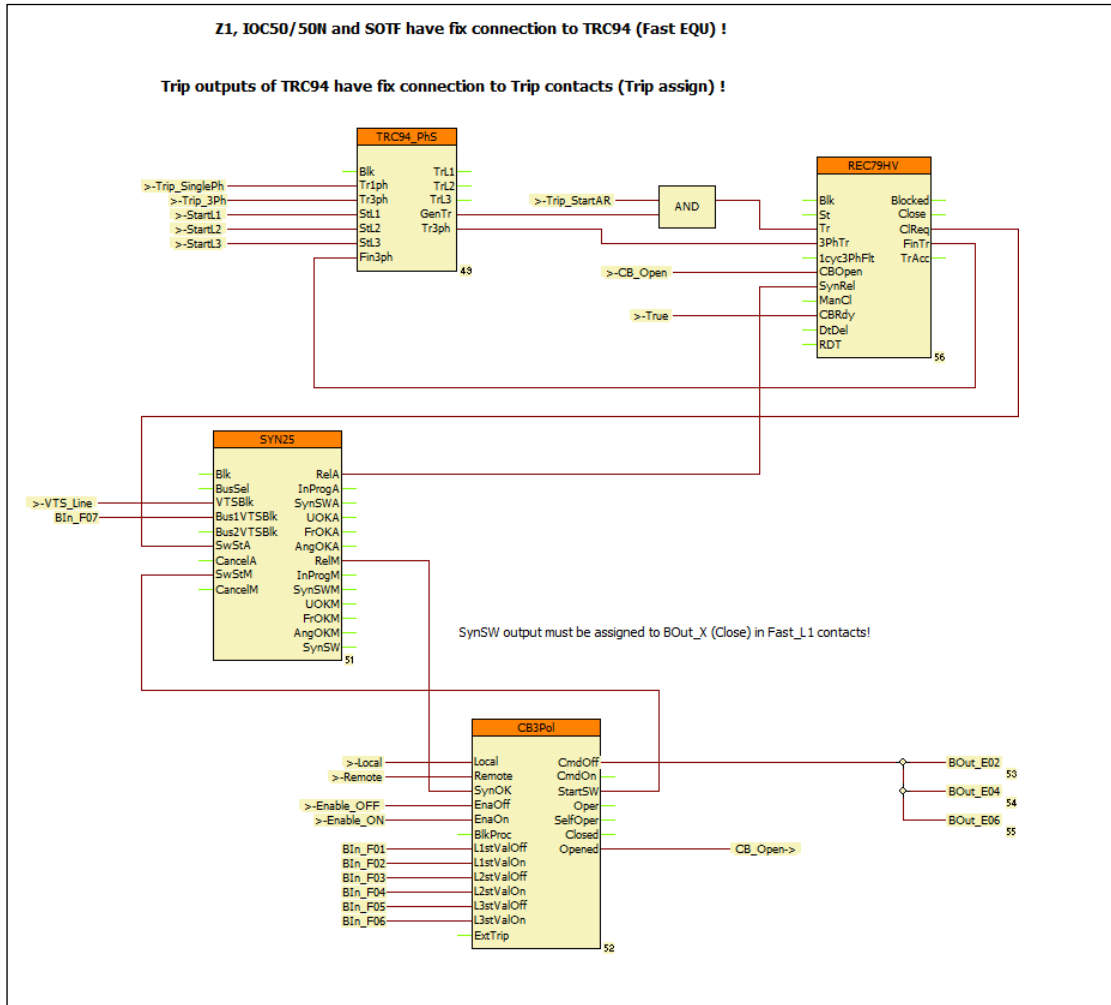

Figure 5-5 Example: closing the circuit breaker with synchro-check and synchro- switch

Figure 5-5 shows an example for the application of “SYN25” cynchro-check functionblock with synchro switch extension. In this Figure it is supposed that the fast protection functions operate according to the factory configuration and they control the TRIP contacts applying two steps of the preparation and command generation phases. This part of the program is not visible in “Master” level. (The description of the fast operating protection functions are listed in the configuration description of the devices.)

The outputs of the TRC94_PhS trip logic block are assigned to the output channels of the TRIP hardware module. This assignment, which can be modified also by the user, is made not here but in the “TRIP assignment” menu of the EuroCAP configuration software. Consequently the Figure is complete; related to the outputs, the user needs additional graphic programming only if e.g. the operation is to be visualized also by signal relays.

If the configuration includes protection functions blocks the trip command of which does not need fast contact operation then these commands must be additionally assigned to the TRIP relay outputs. To do this, the user collects these commands



(with OR connection) and assigns them to the dedicated inputs of the TRC94_PhS functionblock.

This Figure shows the collected signals (E.g. “Trip_SinglePh”, “Trip_3Ph”, etc.) only. As an example the „Trip_3ph” signal collects the commands of all (not fast operating) protection functions which can generate three-phase trip command. The detailed description of the inputs and operation of the “TRC94_PhS” trip logic functionblock can be found in another document.

In this configuration also the „CB3pol” (circuit breaker control block) is applied. This block is needed if e.g. the front panel LCD of the device can display an active control scheme. For this purpose the signals „BIn_F...” in the Figure are the status signals of the circuit breaker poles, connected to the dedicated binary inputs of the device. The signals „Local”/”Remote” enable the local or remote control of the primary equipment. In the standard factory configurations these signals are programmed in the factory, but they can be modified also by the user.

According to *Figure 5-5*, the local command issued via LCD of the device or the remote command received from the remote SCADA system is processed by the „CB3pol” functionblock (Output „CmdOff”). This control is programmed in the factory to “BOut_xx” variables. The user can perform any modification in the graphic programming.

The close command is connected directly to a dedicated “BOut_xx” variable. (This directs usually the fourth contact of the TRIP hardware module.)

In *Figure 5-5* the close command is connected directly to a dedicated output. (This is usually the fourth contact of the TRIP hardware module.)

The programming of the interlocking function must be performed by the user.

Figure 5-5 includes the application of the „REC79_HV” automatic reclosing function. The start signal „Trip_StartAR” can be programmed by the user. The automatic reclosing function is started only if the preceding trip command was performed by the circuit breaker, i.e. for example that the function is not disabled. The AND gate on this Figure performs this checking.

The „REC79_HV” automatic reclosing function needs the status signal indicating three-phase open state of the circuit breaker, connected to the „3PhTr” input of the „REC79_HV” functionblock. This signal is generated by the „TRC94_PhS” functionblock on the output „Tr3Ph”.

If the automatic reclosing is to be disabled after a fault caused by a manual close command, then the „CmdOn” output of the „CB3Pol” module must be connected to the „ManCl” input of the „REC79_HV” automatic reclosing function.

If there is no synchro-check function configured in the device, then connect the „SynRel” input of the „REC79_HV” automatic reclosing function to logic TRUE state.

The evaluation of the status signals indicating the open state of the circuit breaker poles in OR gate is needed for the operation of the automatic reclosing function. According to the scheme of *Figure 5-5* the open state is indicated by at least one pole open state of the circuit breaker. (For simplicity, this Figure shows a realization without checking the FALSE signal of the closed states.)

Figure 5-5 supposes that the CB ready signal is not connected to the device; accordingly the steady TRUE state signal is connected to the „CBRdy” input of the „REC79_HV” automatic reclosing function. If the real signal is available, the signal must be connected similarly.

The close command of the „REC79_HV” automatic reclosing function is connected via OR gate to the dedicated close contact.

In this application the close command to the circuit breaker is generated by synchro-check. The enabling signal for the close command is generated by the „SYN25” software module. This module is described in details in a separate document. The

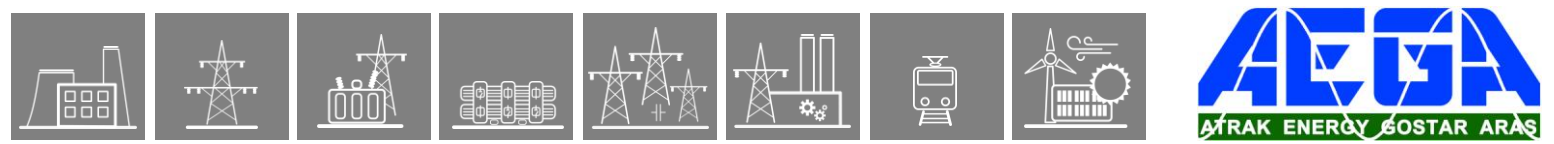

needed input signals indicating the state of the voltage transformers („VTSBIK” and „Bus1VTSBIK”), must be programmed graphically.

The output signal „RelA” of the „SYN25” software module enables the closing operation of the „REC79_HV” automatic reclosing function via its „SynRel” input.

For manual close commands the output signal „RelM” of the „SYN25” software module enables the closing operation of the „CB3pol” via its „SynOK” input.

An extension to the example in *Figure 5-4* is the following: If there is no continuous synchron state because the frequency at one side of the circuit breaker is different to that of the other side, then the voltage vector of one side rotates continuously as compared to the other one. In this case a synchronous switching is attempted to restore the normal operation of the network.

The manual synchron switching mode is started by the signal on the „StSwM” input of the SYN25 functionblock. To do this the the „StartSW” output of the „CB3Pol” functionblock must be connected here.

For automatic synchron switching mode the „CIReq” output of the „Rec79HV” module must be connected to the „SwStA” input of the „SYN25” software module.

IMPORTANT NOTE: the close command is generated for both manual and automatic

switching at the output „SynSW” of the „SYN25” software module. It is advised not to connect this output using the „slow” graphic programming, but the contact assigned to the close command („BOutClose”) must be handled as fast operating „L1 contact”. The „SynSW” signal must be programmed to this contact. This assignment is performed using the EuroCap configuration tool in the menu „Hardware configuration/Binary outputs/Relay contacts/Fast_L1 contacts”.

1.2.10. RTD input module

The RTD+1100 module is used to measure the temperature through the variation of resistance of temperature detectors. RTD+0200 and RTD+1200 are special modules for Petersen coil controllers (DRL) measuring the resistance of the potentiometer.

Connector types:

- The default and optionally available connector types are indicated for each module in the table below. See Chapter 20.2 for details about each type.

MODULE TYPE	RTD+/0200*	RTD+/1100	RTD+/1200*
CHANNEL NUMBER	1	4	1
MEASUREMENT METHOD	3 wire configuration	2, 3 or 4 wire configuration	3 wire configuration
ACCURACY	± 0.5 % ± 1 digit	± 0.5 % ± 1 digit	± 0.5 % ± 1 digit
SENSOR TYPE	Service-Ohm	Pt100/Ni100 Ni120/Ni120US Pt250/Ni250 Pt1000/Ni1000 Cu10 Service-Ohm (60 Ω ... 1.6 kΩ)	Service-Ohm
MEASUREMENT RANGES	2 Ω ... 200 Ω	- 50 °C – +150 °C	10 Ω ... 1000 Ω
CONNECTOR TYPE	<u>Default:</u> BLA <u>Options:</u> -	<u>Default:</u> BLA <u>Options:</u> T	<u>Default:</u> BLA <u>Options:</u> -
RECOMMENDED APPLICATION	Arc suppression coil controller	General resistance-based temperature measurement	Arc suppression coil controller

*Special module

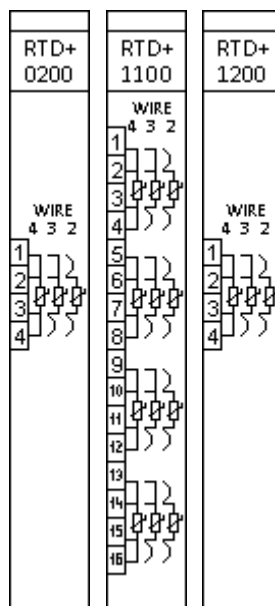

Figure 10-1 RTD input modules

1.2.10.1. RTD module wiring

If 2-wire wiring is used you have to make sure that the value of RA and RD resistors are set correctly in the “parameters” menu of the web server.

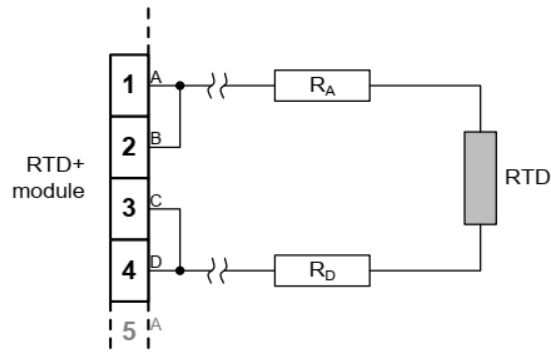

Figure 10-2 2-wire RTD wiring

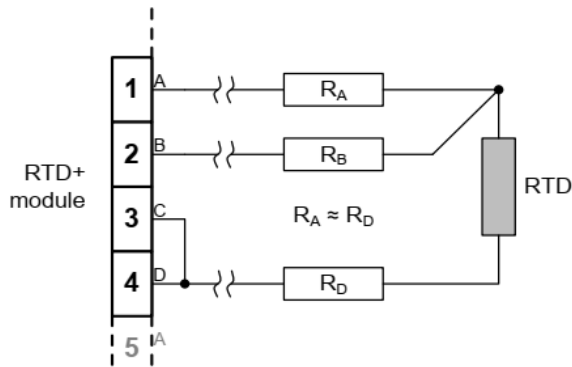

Figure 10-3 3-wire RTD wiring

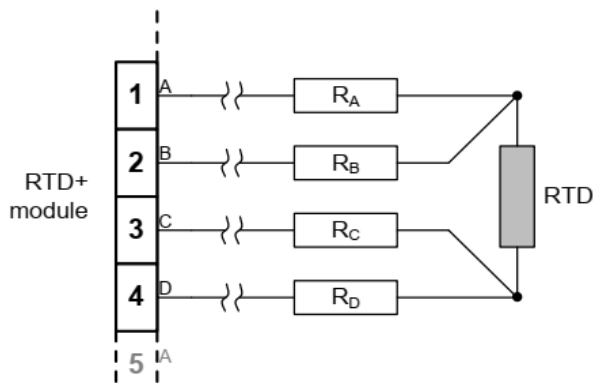

Figure 10-4 4-wire RTD wiring

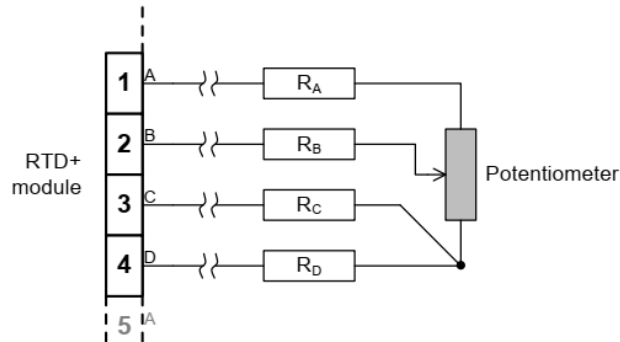

Figure 10-5 4-wire RTD wiring of potentiometer

1.2.11. Analog input module (AI)

The analog input module accepts transducers' current outputs. The AIC module can measure unipolar and bipolar current values in wide ranges.

Connector types:

- The default and optionally available connector types are indicated for each module in the table below. See Chapter 20.2 for details about each type.

MODULE TYPE	AIC+/0200*	AIC+/0201*	AIC+/0202
CHANNEL NUMBER	4	4	4
MEASUREMENT METHOD	2 wire inputs	2 wire inputs with optional 12 V excitation	2 wire inputs
RELATIVE ACCURACY	$\pm 0.5 \% \pm 1$ digit	$\pm 0.5 \% \pm 1$ digit	$\pm 0.5 \% \pm 1$ digit
MEASUREMENT RANGES	± 20 mA (typical 0-20, 4-20 mA) $R_{LOAD} = 56 \Omega$	± 20 mA (typical 0-20, 4-20 mA) $R_{LOAD} = 56 \Omega$	± 20 mA (typical 0-20, 4-20 mA) $R_{LOAD} = 56 \Omega$
CONNECTOR TYPE	<u>Default:</u> BLA <u>Options:</u> -	<u>Default:</u> BLA <u>Options:</u> -	<u>Default:</u> BLA <u>Options:</u> F, T

***Obsolete module. These modules are not recommended for new designs!**

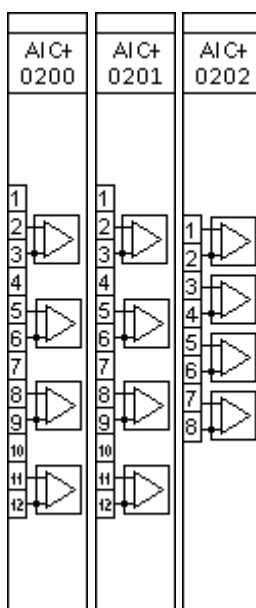

Figure 11-1 Analog input modules

1.2.11.1. AI module wiring

The following wiring method can be applied.

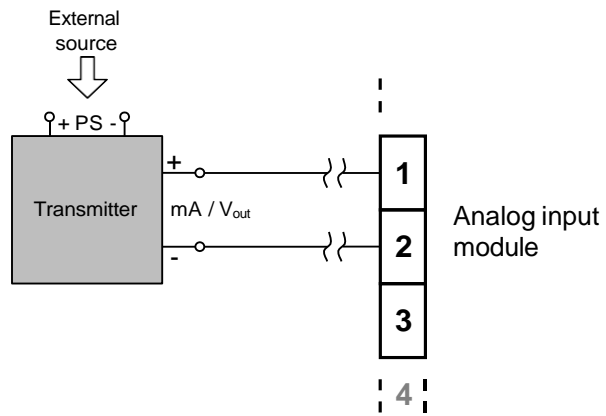

Figure 11-2 AI wiring

1.2.12. Analog output module (ATO)

The analog output module transmits current or voltage signals. The ATO module can be used in wide ranges in unipolar and bipolar mode.

Connector types:

- The default and optionally available connector types are indicated for each module in the table below. See Chapter 20.2 for details about each type.

MODULE TYPE	ATO+/0002	ATO+/0004
CHANNEL NUMBER	2	4
OUTPUT MODE	2 wire output	2 wire output
MAXIMUM LOAD ($R_{\text{CABLE}} + R_{\text{RECEIVER}}$)	500 Ω	500 Ω
OUTPUT RANGES	± 20 mA 0 - 20 mA 4 - 20 mA	± 20 mA 0 - 20 mA 4 - 20 mA
CONNECTOR TYPE	Default: BLA Options: T	Default: BLA Options: -

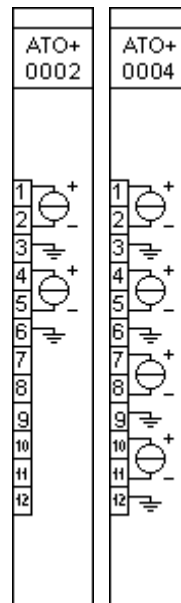

Figure 12-1 Analog output modules

1.2.12.1. ATO module wiring

The analog output module should be connected according to the following wiring diagram.

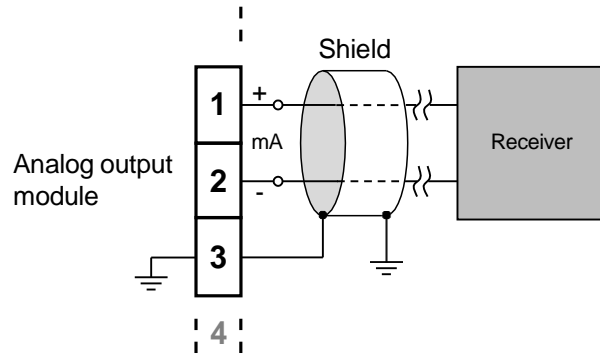

Figure 12-2 Analog output module wiring diagram

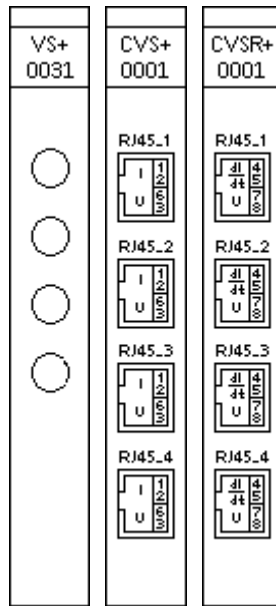
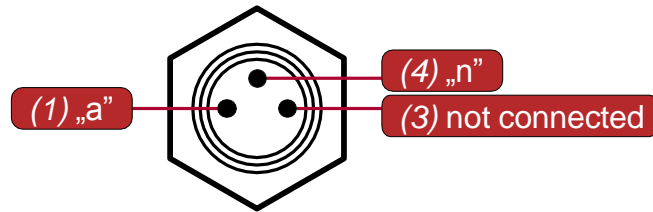

Figure 13-1 Voltage sensor modules



(FRONT VIEW)

Figure 13-2 M8 connector pinout



- 1.: S1
- 2.: S2
- 3.: "a"
- 6.: "n"

Figure 13-3 CVS module connector pinout



- 4.: S1
- 5.: S2
- 8.: "n"
- 7.: "a"

Figure 13-4 CVSR module connector pinout

1.2.14. INJ module

Complex module for controlling the Petersen coil, which contains an injector function for the measurements, an enabling and a blocking input, and a fault relay indicating if there is any fault in the injection circuit.

Connector types:

- The default and optionally available connector types are indicated for each module in the table below. See Chapter 20.2 for details about each type.

MODULE TYPE	INJ+/0005	INJ+/0015*
INJECTED CURRENT	2 A	4 A
ENABLING INPUT CLAMP VOLTAGE	85 V AC	Not available function
BLOCKING INPUT CLAMP VOLTAGE	200 V AC	200 V AC
ADDITIONAL RESISTANCE FOR VOLTAGE INPUT	Not available function	265 kΩ ± 1%
CONNECTOR TYPE	Default: STVS6, BLA10 Options: -	
RECOMMENDED APPLICATION	Arc suppression coil controller	Network compensation level measurement on resonant grounded networks

*Special module

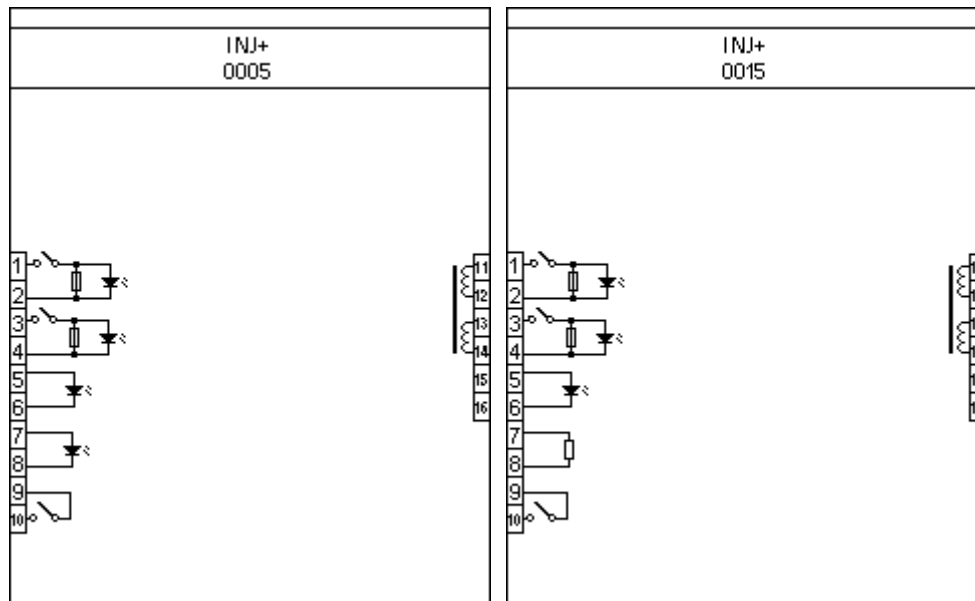

Figure 14-1 INJ modules

1.2.15. Generator protection modules

Special generator protection modules whose system measures and produces the necessary analog signals.

Connector types:

- The default and optionally available connector types are indicated for each module in the tables below. See Chapter 20.2 for details about each type.

MODULE TYPE	RAI+/01	RAI+/11	RINJ+/21
NOMINAL VOLTAGE	-	-	110 V / 220 V
INPUT VOLTAGE RANGE	-	-	88 - 264 V DC 80 - 250 V AC
OUTPUT VOLTAGE	-	-	100V DC \pm 2 %
MEASUREMENT RANGE	\pm 20 mA	\pm 20 mA	-
THERMAL WITHSTAND CONTINUOUS: 30 SEC:	15 mA 20 mA	10 mA 20 mA	20 mA
CONNECTOR TYPE	<u>Default:</u> STVS8 <u>Options:</u> -	<u>Default:</u> STVS8 <u>Options:</u> T*	<u>Default:</u> STVS8 <u>Options:</u> T*
RECOMMENDED APPLICATION	Rotor earth-fault protection of middle-grounded rotors	Rotor earth-fault protection of ungrounded (isolated) rotors	Rotor earth-fault protection of ungrounded (isolated) rotors

*By choosing this option, the connector remains the same, only the handle is changed

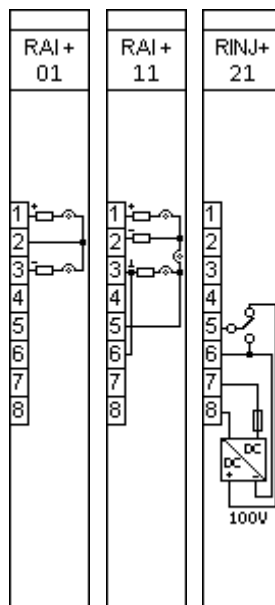

Figure 15-1 Generator protection modules

1.2.15.1. Auxiliary boxes for rotor earth fault protection

These DIN-rail mounted external boxes serve as couplings between the rotor (exciter circuit) of the generator and the corresponding RAI module of the protection device.

Note: the data about the resistances and capacitors provided here does not tell the actual time constants of the measured values, as those can be determined on-site only, when the rotor earth fault protection is being tested on the actual generator itself.

MODULE TYPE	RAI+01 BOX	RAI+11 BOX BASE	RAI+11 BOX EXTENSION*
MAXIMUM INPUT VOLTAGE	200 V, 300 V, 400 V, 500 V**	600 V	1200 V
SERIES RESISTANCE ON SIDES	10 kΩ, 15 kΩ, 20 kΩ, 25 kΩ**	35 kΩ	30 kΩ
FILTER CAPACITORS	4x10 μF	2x1 μF	-
CONNECTOR TYPE	Default: STVS6 Options: -	Default: STVS6 Options: -	Default: STVS6 Options: -
RECOMMENDED APPLICATION	Middle-grounded rotors	Ungrounded (isolated) rotors	Ungrounded (isolated) rotors

*This extension module can only be used together with RAI+11 BOX BASE module

**According to the chosen wiring

1.2.15.1.1. Use of auxiliary boxes

A) Ungrounded (isolated) rotors:

If the excitation voltage is lower than 600 V, then it is enough to use the RAI+11 BOX BASE auxiliary box. If the excitation voltage is higher than 600 V, the RAI+11 BOX EXTENSION auxiliary box shall be used *additionally*, so the protection can connect to up to 1200 V excitation voltage.

B) Middle-grounded rotors

Front drawings near the connectors on the box itself indicate the available maximum voltages. The choice from these shall be made according to the excitation voltage. Wiring shall be done according to the chosen voltage.

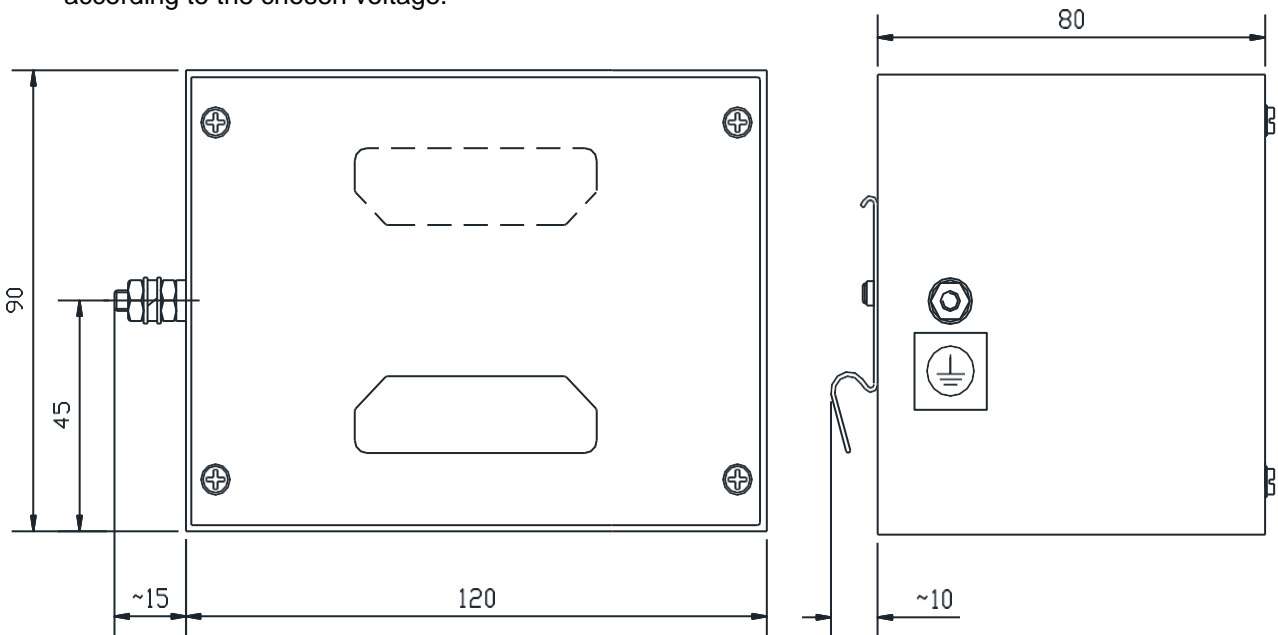

Figure 15-2 Size of the auxiliary boxes

1.2.15.2. Wiring of the rotor earth fault protection modules

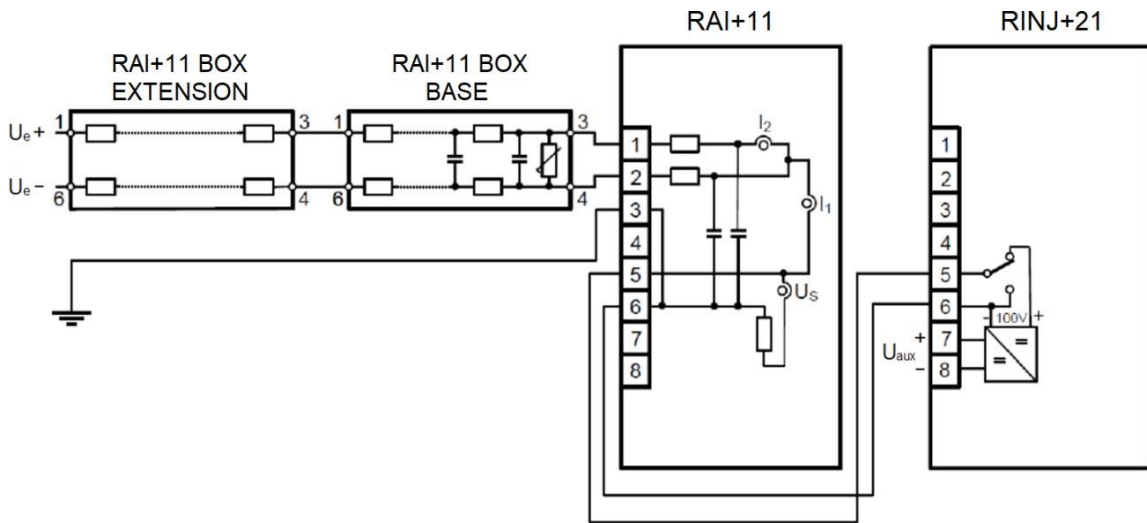

Figure 15-3 Wiring for ungrounded (isolated) rotors

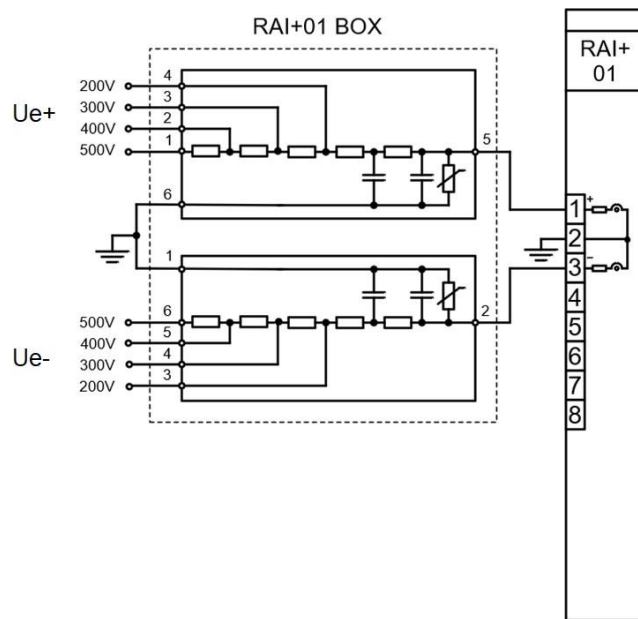
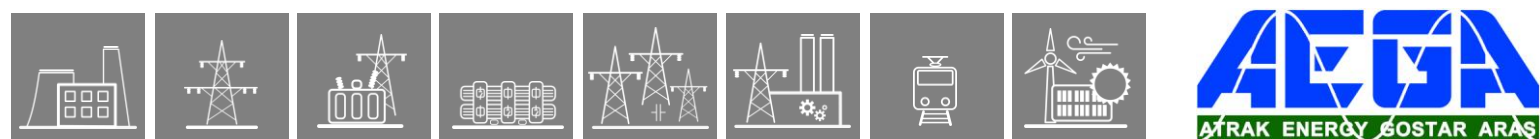

Figure 15-4 Wiring for middle-grounded rotors



1.2.16. Power supply module

The power supply module converts primary AC and/or DC voltage to required system voltages. In most applications, one power supply module is sufficient to provide the required power to the system. Redundant power supply modules extend system availability in case of the outage of any power source.

IMPORTANT

Depending on the hardware configuration, the power consumption of the devices can be different. We reserve the right to make the decision about which PS+ module must be used.

For most applications where the power consumption does not reach 20 W, a 4 HP wide PS+ module shall be installed.

Connector types:

- *The default and optionally available connector types are indicated for each module in the tables below. See Chapter 20.2 for details about each type.*

MODULE TYPE	PS+/4201 (4 HP wide)	PS+/2101 (4 HP wide)
RATED VOLTAGE	24 V DC / 48 V DC / 60 V DC	110 V DC / 220 V DC
INPUT VOLTAGE OPERATIVE RANGE	19.2 - 72 V DC	88 - 264 V DC 80 - 250 V AC
NOMINAL POWER	20 W	20 W
VOLTAGE DIP WITHSTAND AT 80% UN → 0% INPUT VOLTAGE CHANGE (IEC 60255-26)	50 ms	100 ms
INTERNAL FUSE	3.15A/250V	3.15A/250V
CONNECTOR TYPE	<u>Default:</u> BLA <u>Options:</u> T	<u>Default:</u> BLA <u>Options:</u> F, T

IMPORTANT

Devices with 20W or higher power consumption shall be equipped with an 8 HP wide PS module.

MODULE TYPE	PS+/1301	PS+/1303**	PS+/2301	PS+/2303**	PS+/1030*
RATED VOLTAGE	110 V DC	110 V DC	220 V DC	220 V DC	110 V DC / 220 V DC
INPUT VOLTAGE OPERATIVE RANGE	88 - 132 V DC 85 - 130 V AC	88 - 150 V DC 85 - 130 V AC	176 - 264 V DC 160 - 250 V AC	176 - 264 V DC 160 - 250 V AC	88 - 264 V DC 85 - 250 V AC
MAX. CONTINUOUS POWER OUTPUT	30 W	30 W	30 W	30 W	25 W
VOLTAGE DIP WITHSTAND AT 80% UN → 0% INPUT VOLTAGE CHANGE (IEC 60255-26)	50 ms 100 ms at 100%Un → 0%	50 ms 100 ms at 100%Un → 0%	50 ms 100 ms at 100%Un → 0%	50 ms 100 ms at 100%Un → 0%	20 ms 100 ms at 100%Un → 0%
INTERNAL FUSE	2.5A/250V	2.5A/250V	2.5A/250V	2.5A/250V	2.5A/250V
CONNECTOR TYPE	<u>Default:</u> BLA <u>Options:</u> -	<u>Default:</u> BLA <u>Options:</u> -	<u>Default:</u> BLA <u>Options:</u> -	<u>Default:</u> BLA <u>Options:</u> -	<u>Default:</u> BLA <u>Options:</u> F, T

*Special module, available only in custom configurations.

**Can be connected in parallel.

MODULE TYPE	PS+/1060*	PS+/1601	PS+/1602*	PS+/2601	PS+/4301***
RATED VOLTAGE	110 V DC / 220 V DC	110 V DC	110 V DC	220 V DC	48 V DC
INPUT VOLTAGE OPERATIVE RANGE	88 - 264 V DC	88 - 132 V DC 95 - 130 V AC	88 - 132 V DC 95 - 130 V AC	176 - 264 V DC 160 - 250 V AC	38.4 - 57.6 V DC
MAX. CONTINUOUS POWER OUTPUT	60 W	60 W	60 W	60 W	25 W
VOLTAGE DIP WITHSTAND AT 80% UN → 0% INPUT VOLTAGE CHANGE (IEC 60255-26)	20 ms 100 ms at 100%Un → 0%	50 ms 100 ms at 100%Un → 0%	50 ms 100 ms at 100%Un → 0%	50 ms 100 ms at 100%Un → 0%	20 ms 30 ms at 100%Un → 0%
INTERNAL FUSE	3.15A/250V	2.5A/250V	2.5A/250V	2.5A/250V	3.15A/250V
CONNECTOR TYPE	<u>Default:</u> BLA <u>Options:</u> F, T	<u>Default:</u> BLA <u>Options:</u> -	<u>Default:</u> BLA <u>Options:</u> F	<u>Default:</u> BLA <u>Options:</u> T	<u>Default:</u> BLA <u>Options:</u> -

*Special module, available only in custom configurations. PS+1602 supports **auxiliary voltage measurement**. The module is calibrated to DC voltage measurement.

***Obsolete module. These modules are not recommended for new designs!

- Early power failure indication signals to the CPU for the possibility of power outage, thus the CPU has enough time to save the necessary data to non-volatile memory
- Inrush current (until 0.1 s): < 10 A for all types excluding PS+4401 which has < 21 A inrush current.
- Common features for internal fuses:
 - 5 mm x 20 mm (0.20" x 0.79")
 - TT characteristics (very inverse time-lag)
 - 35 A @ 250 V AC rated breaking capacity
- Recommended external protection: miniature circuit breaker, 6 A (C char.)

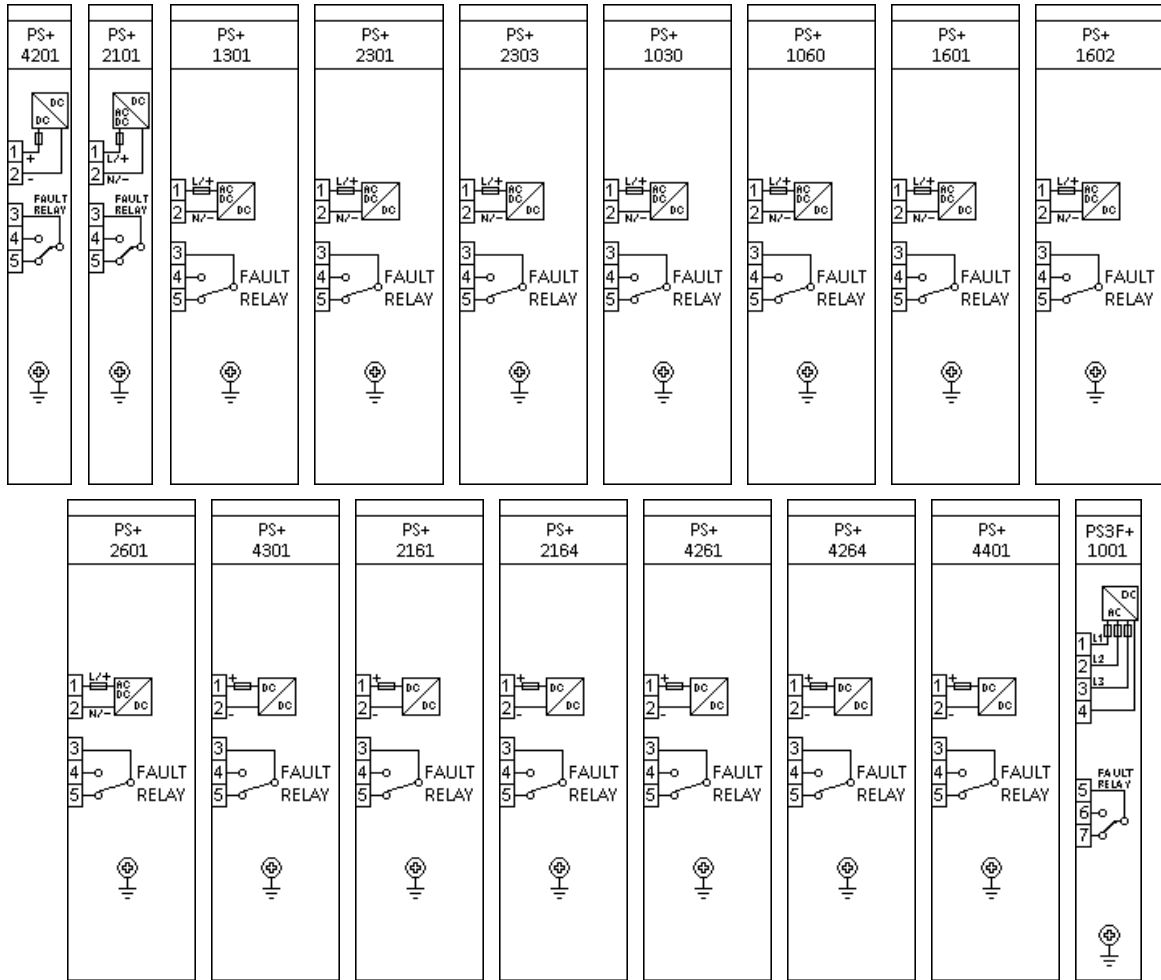

Figure 16-1 Power supply modules

1.2.17. Sampling synchronization module

The IED sampling system is synchronized via this module to an external source (IRIG-B) in PMU (Phasor Measurement Unit) applications. The PLL of the module handles the setting of the phase and frequency if valid IRIG-B signal is received. Note that the sampling signal is generated even if the IRIG-B signal is not present, however in that case, it runs independently.

MODULE TYPE	TSYNC+/0071
IRIG-B TYPE	B000 (unmodulated)
INPUT TYPE	BNC (coaxial)
SIGNAL THRESHOLD	5 VDC CMOS max. 5.5 VDC
MAX. CABLE LENGTH	50 m
CLAMP VOLTAGES	falling 1.7 VDC rising 3.1 VDC
SAMPLING ACCURACY*	< 100 ns
IRIG SYNCH. TIME	max. 1 minute
HOLDOVER TIME**	30 s
SAMPLING FREQUENCY	2 kHz @ 50 Hz 2.4 kHz @ 60 Hz
SAMPLING ACCURACY IN INDEPENDENT MODE***	< 1 ppm

*max. time difference between synchronized systems connecting to different GNSS (e.g. GPS)

**the sampling accuracy stays below the given value during this time if the IRIG-B signal is lost

***the accuracy of the 2/2.4 kHz sampling signal if an IRIG-B signal is not present

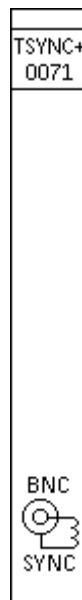

Figure 17-1 Sampling synchronization module

1.2.18. Mixed function modules

1.2.18.1. PSTP+ module

IMPORTANT

PSTP+ modules can be used only if the power consumption of the device does not reach 20 W and maximum 2 TRIP contacts are needed. If the application does not meet any of these two requirements, it is not allowed to use these cards. In this case separate PS+ (Chapter 16) and TRIP+ (Chapter 9) modules must be used.

Connector types:

- The default and optionally available connector types are indicated for each module in the tables below. See Chapter 20.2 for details about each type.

Note for the following tables:

- Thermal withstand voltage:** continuous with 60 % of the input channels are energized.

MODULE TYPE	PSTP+/2101	PSTP+/2102*	PSTP+/2131**
	POWER SUPPLY CHARACTERISTICS		
RATED VOLTAGE	110 V / 220 V	110 V / 220 V	110 V / 220 V
INPUT VOLTAGE OPERATIVE RANGE	88 - 264 V DC 80 - 250 V AC	88 - 264 V DC 80 - 250 V AC	88 - 264 V DC 80 - 250 V AC
MAXIMUM CONTINUOUS POWER OUTPUT	20 W	20 W	20 W
VOLTAGE DIP DURATION AT 0% RESIDUAL VOLTAGE (IEC 60255-26)	min. 100 ms in the specified input voltage range	min. 100 ms in the specified input voltage range	min. 100 ms in the specified input voltage range
INTERNAL FUSE	3.15A/250V	3.15A/250V	3.15A/250V
CONNECTOR TYPE	Default: BLA Options: F, T	Default: BLA Options: F, T	Default: BLA Options: T
	TRIPPING CHARACTERISTICS		
CHANNEL NUMBER	2	2	2
RATED VOLTAGE	110 V DC and 220 V DC or dry contacts	110 V DC and 220 V DC or dry contacts	110 V DC and 220 V DC or dry contacts
THERMAL WITHSTAND VOLTAGE	242 V DC	242 V DC	242 V DC
CONTINUOUS CARRY	8 A	8 A	8 A
MAKING CAPACITY	0.5 s, 30 A	0.5 s, 30 A	0.5 s, 30 A
BREAKING CAPACITY	L/R = 40 ms: 4 A DC	L/R = 40 ms: 4 A DC	L/R = 40 ms: 4 A DC
CONNECTOR TYPE	Default: BLA Options: F, T	Default: BLA Options: F, T	Default: BLA Options: T

*Special module that supports **auxiliary voltage measurement**. The module is calibrated to DC voltage measurement.

**Without trip circuit supervision

MODULE TYPE	PSTP+/4201	PSTP+/4202*
	POWER SUPPLY CHARACTERISTICS	
RATED VOLTAGE	24 V / 48 V / 60 V	24 V / 48 V / 60 V
INPUT VOLTAGE OPERATIVE RANGE	19.2 - 72 V DC	19.2 - 72 V DC
MAXIMUM CONTINUOUS POWER OUTPUT	20 W	20 W
VOLTAGE DIP DURATION AT 0% RESIDUAL VOLTAGE (IEC 60255-26)	50 ms at nominal input voltages min. 40 ms in the specified input voltage range	50 ms at nominal input voltages min. 40 ms in the specified input voltage range
INTERNAL FUSE	3.15A/250V	3.15A/250V
CONNECTOR TYPE	<u>Default:</u> BLA <u>Options:</u> T	<u>Default:</u> BLA <u>Options:</u> T
	TRIPPING CHARACTERISTICS	
CHANNEL NUMBER	2	2
RATED VOLTAGE	24 V DC and 48 V DC or dry contacts	24 V DC and 48 V DC or dry contacts
THERMAL WITHSTAND VOLTAGE	72 V DC	72 V DC
CONTINUOUS CARRY	8 A	8 A
MAKING CAPACITY	0.5 s, 30 A	0.5 s, 30 A
BREAKING CAPACITY	L/R = 40 ms: 4 A DC	L/R = 40 ms: 4 A DC
CONNECTOR TYPE	<u>Default:</u> BLA <u>Options:</u> T	<u>Default:</u> BLA <u>Options:</u> T

***Special module** that supports **auxiliary voltage measurement**. The module is calibrated to DC voltage measurement.

Main features:

- High-speed operation: with pre-trip 0.5 ms, without pre-trip typically 10 ms, maximally 22 ms.
- Trip circuit supervision for each trip contact
- 1 unit wide (4 HP) modules
- Inrush current (until 0.1 s): < 10 A
- Common features for internal fuses:
 - 5 mm x 20 mm (0.20" x 0.79")
 - TT characteristics (very inverse time-lag)
 - 35 A @ 250 V AC rated breaking capacity
- Recommended external protection: miniature circuit breaker, 6 A (C char.)

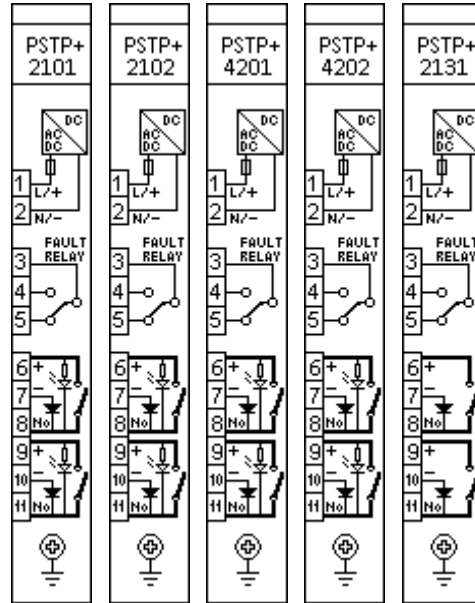

Figure 18-1 Power supply with 2 Ch. TRIP modules

1.2.18.1.1. Trip Circuit Supervision (TCS) in PSTP modules

Apart from the PSTP+/2131, all PSTP modules have TCS.

The technical data of the TCS in PSTP modules:

MODULE TYPE	PSTP+/4201 PSTP+/4202	PSTP+/2101 PSTP+/2102
INJECTED CURRENT AT "NO" CONTACT	1.5 mA	1.5 mA
3-WIRE WIRING (1 mA CURRENT)	8 kΩ (max. 8 V)	13 kΩ (max. 13 V)
3-WIRE WIRING IN PARALLEL	4 kΩ (max. 8 V)	6.5 kΩ (max. 13 V)
2-WIRE METHOD (1 mA MIN. CURRENT)	24 kΩ @ 24 V DC 48 kΩ @ 48 V DC 60 kΩ @ 60 V DC	110 kΩ @ 110 V DC 220 kΩ @ 220 V DC

IMPORTANT

PSR2+ modules can be used only if the power consumption of the device does not reach 20 W and maximum 2 contacts are needed. If the application does not meet any of these two requirements it is not allowed to use these cards. In this case separate PS+ (Chapter 16) and Signaling (Chapter 8) modules must be used.

1.2.18.2. PSR2+ module

Connector types:

- The default and optionally available connector types are indicated for each module in the table below. See Chapter 20.2 for details about each type.

MODULE TYPE	PSR2+/2101
POWER SUPPLY CHARACTERISTICS	
RATED VOLTAGE	110 V / 220 V
INPUT VOLTAGE OPERATIVE RANGE	88 - 264 V DC 80 - 250 V AC
MAXIMUM CONTINUOUS POWER OUTPUT	20 W
VOLTAGE DIP DURATION AT 0% RESIDUAL VOLTAGE (IEC 60255-26)	min. 100 ms in the specified input voltage range
INTERNAL FUSE	3.15A/250V
CONNECTOR TYPE	<u>Default:</u> BLA <u>Options:</u> T
SIGNALING RELAY CHARACTERISTICS	
CHANNEL NUMBER	2
RATED VOLTAGE	250 V AC/DC
CONTINUOUS CARRY	8 A
MAKING CAPACITY	0.5 s, 30 A
CONNECTOR TYPE	<u>Default:</u> BLA <u>Options:</u> T

Main features (according to IEC 60255-26):

- Maximum switching voltage: 400 V AC
- Breaking capacity: (L/R=40 ms) at 220 V DC: 0.2 A, at 110 V DC: 0.3 A
- Breaking capacity max.: 2000 VA
- Short time carrying capacity: 1 s, 35 A
- Limiting making current, max. 4 s: 15 A (df = 10 %)
- Dielectric strength between open contacts, 1 min: 1000 V_{RMS}
- Mechanical endurance: 10 × 10⁶ cycles
- Circuit closing capability: typically 10 ms, maximally 22 ms.
- Bounce time: typically 6,5 ms, maximally 10 ms.
- Minimal switching requirement: 5 V

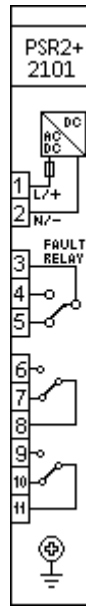
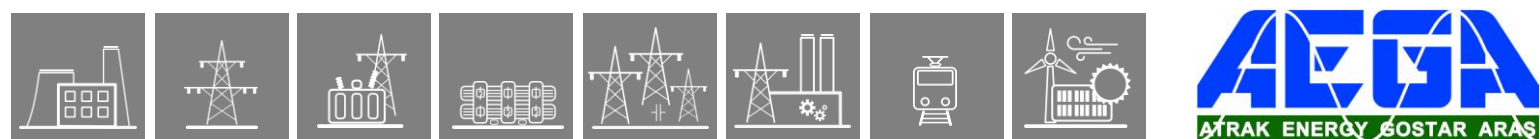

Figure 18-2 Power supply with 2 Ch. signaling modules



1.2.18.3. O6R5+ module

The O6R5+ module contains 6 binary input channels in one grounding group, and 5 relay outputs with 2 × 2 NO contacts and one CO contact.

Connector types:

- The default and optionally available connector types are indicated for each module in the tables below. See Chapter 20.2 for details about each type.

Notes for the following table:

- **Thermal withstand voltage:** continuous with 60 % of the input channels are energized.
- **Clamp voltage:** these are the guaranteed values; the actual ones might differ from those provided here (falling and rising around 0.66 U_N and 0.77 U_N , respectively)

MODULE TYPE	O6R5+/2101	O6R5+/4201
BINARY INPUT CHARACTERISTICS		
CHANNEL NUMBER	6	6
RATED VOLTAGE	110 V / 220 V user selectable on channel basis by jumpers	24 V / 48 V user selectable on channel basis by jumpers
TIME SYNCHRONIZATION	configured by EuroCAP	configured by EuroCAP
THERMAL WITHSTAND VOLTAGE	320 V	72 V
CLAMP VOLTAGE	falling 0.64 U_N rising 0.8 U_N	falling 0.64 U_N rising 0.8 U_N
COMMON GROUPS	1 × 6 common	1 × 6 common
RELAY OUTPUT CHARACTERISTICS		
RATED VOLTAGE	250 V AC/DC	250 V AC/DC
CONTINUOUS CARRY	8 A	8 A
CONTACT VERSIONS	4 NO, 1 CO	4 NO, 1 CO
GROUP ISOLATION	2 × 2 common, 1 independent	2 × 2 common, 1 independent
CONNECTOR TYPE FOR BOTH BINARY INPUT AND RELAY OUTPUT	<u>Default:</u> BLA <u>Options:</u> T	<u>Default:</u> BLA <u>Options:</u> T

Main features for binary inputs:

- Digitally filtered per channel
- Current drain:
 - max. 1.6 mA per channel at 220 V DC
 - max. 1.8 mA per channel at 110 V DC
 - max. 2 mA per channel at 48 V DC
 - max. 3 mA per channel at 24 V DC
- In such applications where the input voltage is 60 V the modules with 48 V rated voltage can be used.
- Input voltage type can be either DC or AC voltage. If AC voltage is used make sure that the type and the parameters of the binary inputs are configured properly in EuroCap tool.

Main features for signaling outputs:

- Maximum switching voltage: 400 V AC
- Breaking capacity, (L/R=40 ms) at 220 V DC: 0.1 A, at 110 V DC: 0.2 A
- Breaking capacity max.: 2000 VA
- Short time carrying capacity: 1 s, 35 A
- Limiting making current, max. 4 s: 15 A (df = 10 %)
- Initial dielectric strength between open contacts, 1 min: 1000 V_{RMS}
- Circuit closing capability: typically 10 ms, maximally 22 ms.
- Bounce time: typically 6,5 ms, maximally 10 ms.
- Mechanical endurance: 10 × 10⁶ cycles
- Circuit closing capability

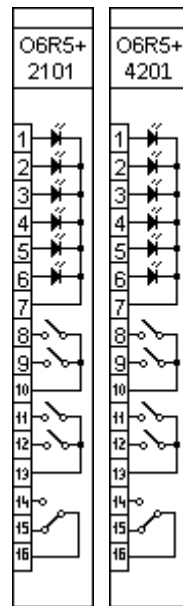
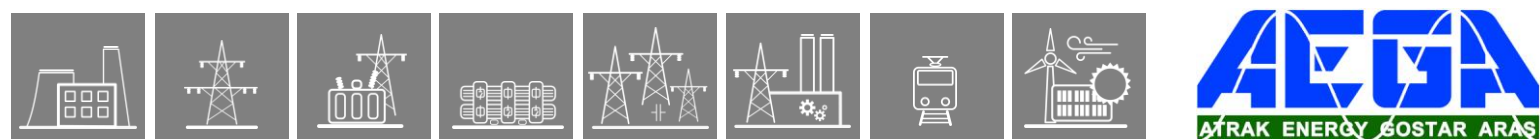

Figure 18-3 Binary input/output modules



1.2.18.4. Binary input module with time synchronization

The inputs are galvanically isolated and the module converts high-voltage signals to the voltage level and format of the internal circuits. This module is also used as an external IRIG-B synchronization (**IRIG-B000, unmodulated**), PPM or PPS input. Dedicated synchronization input is used for this purpose.

Connector types:

- *The default and optionally available connector types are indicated for each module in the tables below. See Chapter 20.2 for details about each type.*

Notes for the following table:

- **Thermal withstand voltage:** continuous with 60 % of the input channels are energized.
- **Clamp voltage:** these are the guaranteed values; the actual ones might differ from those provided here (falling and rising around $0.66 U_N$ and $0.77 U_N$, respectively)

MODULE TYPE	O9S+/2111	O9S+/2121	O9S+/4221
CHANNEL NUMBER	9	9	9
SYNCHRON CHANNEL TYPE AND NUMBER	1 isolated BNC connector	1 850 nm multimode fiber with ST connector	1 850 nm multimode fiber with ST connector
RATED VOLTAGE	110 V DC / 220 V DC user selectable by jumpers	110 V DC / 220 V DC user selectable by jumpers	24 V DC / 48 V DC user selectable by jumpers
THERMAL WITHSTAND VOLTAGE	320 V	320 V	72 V
WITHSTAND VOLTAGE FOR SYNC. INPUT	35 V _{PEAK}	-	-
CLAMP VOLTAGE	falling $0.64 U_N$ rising $0.8 U_N$	falling $0.64 U_N$ rising $0.8 U_N$	falling $0.64 U_N$ rising $0.8 U_N$
COMMON GROUPS	9 (3 × 3 common)	9 (3 × 3 common)	9 (3 × 3 common)
CONNECTOR TYPE	<u>Default:</u> BLA <u>Options:</u> T	<u>Default:</u> BLA <u>Options:</u> F, T	<u>Default:</u> - <u>Options:</u> F, T

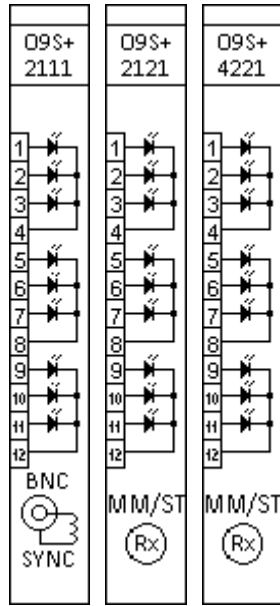

Figure 18-4 Binary input modules with time synchronization

1.2.18.5. Externally driven trip module

The R4MC+01 is a special TRIP module, which can be operated from the connector side. It also has two diode inputs with cathodes which are connected and led to the connector side.

Connector types:

- The default and optionally available connector types are indicated for each module in the tables below. See Chapter 20.2 for details about each type.

Module type	R4MC+/01*
CHANNEL NUMBER	2
RATED VOLTAGE	110 V DC
THERMAL WITHSTAND VOLTAGE	132 V DC
CONTINUOUS CARRY	8 A
MAKING CAPACITY	0.5 s, 30 A
BREAKING CAPACITY	L/R = 40 ms: 4 A DC
DIODE PROPERTIES	1 A, 1000 V DC
CONNECTOR TYPE	<u>Default:</u> BLA <u>Options:</u> F

*Special module



Figure 18-5 Externally driven TRIP module

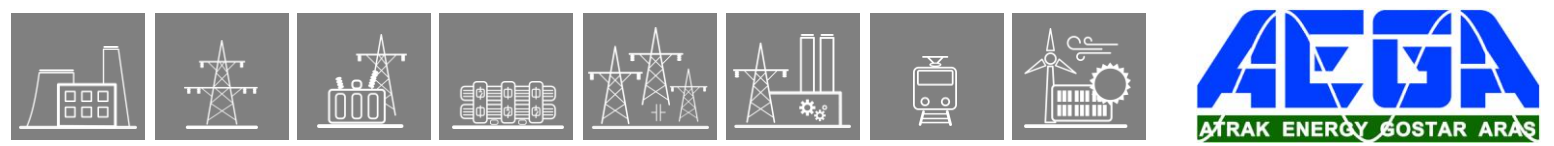

1.2.19. General data

- Storage temperature: - 40 °C ... + 70 °C
- Operation temperature: - 20 °C ... + 55 °C
- Humidity: 10 % ... 93 %
- Altitude: up to 2000 m
- Atmospheric pressure: 86 ... 106 kPa

1.2.19.1. Standard conformance

- Electrostatic discharge immunity (ESD), IEC-EN 60255-26:2013, Level 4
 - Test voltages: 15 kV air discharge, 8 kV contact discharge
- Radiated, radio-frequency, electromagnetic field immunity, IEC-EN 60255-26:2013 Level 3
 - Test field strength: 10 V/m
- Electrical fast transient/burst immunity (EFT/B), IEC-EN 60255-26:2013, Level 4
 - Test voltage: 4 kV
- Surge immunity test, IEC-EN 60255-26:2013
 - Test voltages: 4 kV line-to-earth, 2 kV line-to-line
- Immunity to conducted disturbances, induced by radio-frequency fields, IEC-EN 60255-26:2013, Level 3
 - Test voltage: 10 V
- Damped oscillatory wave immunity test, IEC-EN 60255-26:2013
 - Test frequency: 1 MHz
 - Test voltage: 2.5 kV in common mode, 1 kV in differential mode
- Voltage dips, short interruptions and voltage variations immunity, IEC-EN 60255-26:2013
 - Voltage dips: 40 % (200 ms), 70 % (500 ms), 80 % (5000 ms)
- Ripple on d.c. input power port immunity, IEC-EN 60255-26:2013
 - Level 4, 15 % of rated d.c. value
- Power frequency magnetic field immunity test, IEC-EN 60255-26:2013, Level 5
 - Test field strength: 100 A/m continuous, 1000 A/m for 3 s
- Power frequency immunity test on the binary inputs, IEC-EN 60255-26:2013, Class A
 - Test voltages: 300 V in common mode, 150 V in differential mode
- Insulation tests, IEC-EN 60255-27:2013
 - Impulse voltage test
 - Test levels: 5 kV (1 kV for transducer and temperature measuring inputs)
 - Dielectric test
 - Test levels: 2 kV AC 50 Hz (0.705 kV DC for transducer inputs)
 - Insulation resistance
 - Insulation resistance > 15 GΩ
- Radiated emission, IEC-EN 60255-26:2013

Limits:

 - 30 MHz to 230 MHz: 50 dB(μV/m) quasi peak, 3 m
 - 230 MHz to 1 000 MHz: 57 dB(μV/m) quasi peak, 3 m
 - 1 GHz to 3 GHz: 76 dB(μV/m) peak, 3 m
 - 3 GHz to 6 GHz: 80 dB(μV/m) peak, 3 m
- Conducted emission, IEC-EN 60255-26:2013

Limits:

 - 0,15 MHz to 0,50 MHz: 79 dB(μV) quasi peak, 66 dB(μV) average
 - 0,5 MHz - 30 MHz: 73 dB(μV) quasi peak, 60 dB(μV) average
- Vibration, shock, bump and seismic tests on measuring relays and protection equipment
 - Vibration tests (sinusoidal), Class I, IEC 60255-21-1:1988
 - Shock and bump tests, Class I, IEC 60255-21-2:1988
 - Seismic tests, Class I, IEC 60255-21-3:1993

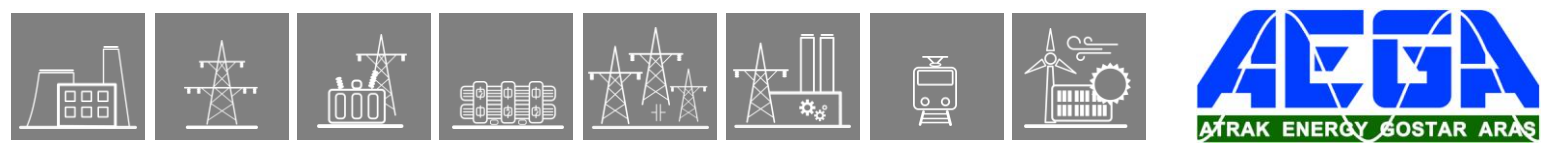

1.2.20. Mechanical data

1.2.20.1. General mechanical data

- Construction: chromate aluminum surface with built-in EMC accessories
 - If the power consumption of a 84 HP or 42 HP device does not exceed 30 W (84 HP) or 14 W (42 HP), the construction will be built with solid top and bottom cover panels.
 - If the power consumption exceeds 30 W (84 HP) or 14 W (42 HP), the construction will be built with (honeycomb) perforated top and bottom cover panels.
- EMC rack protects against electromagnetic environmental influences and protects the environment from radiation from the interior
- IP protection:
 - 24 HP panel instrument case: IP4x; optionally IP54 (front)
 - 84 HP and 42 HP (including double) rack: IP4x from front side, IP2x from rear side; optionally IP54 (front)
- Size:
 - 19" (84 HP), 3 U, single rack
 - ½ 19" (42 HP), 3 U, single rack
 - ½ 19" (42 HP), 6 U, double rack
 - 24 HP, panel instrument case
- Weight:
 - 84 HP: max. 8 kg
 - 42 HP, 3 U: max. 4.5 kg
 - 42 HP, 6 U: max. 8 kg
 - 24 HP: max. 3 kg

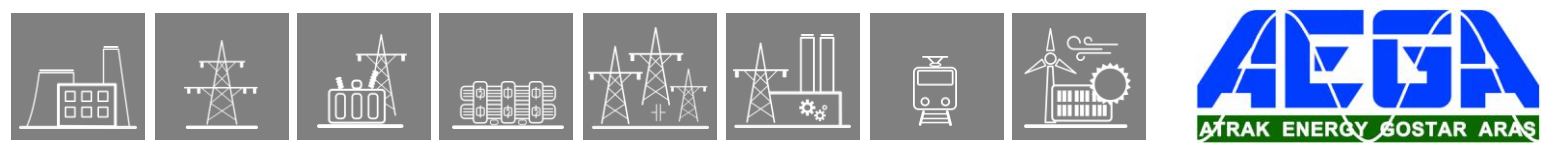

CONNECTOR NAME (SHORT ID)	CONNECTOR TYPES	STRIP LENGTH [MM]	CONDUCTOR AREA [MM ²]	CONDUCTOR DIAMETER [MM]	TIGHTENING TORQUE [Nm]	MINIMUM BEND RADIUS*
STVS(-)	Weidmüller STVS 6 SB, STVS 8 SB	9	0.5 – 4	0.8 – 2.3	0.5 – 0.6	3 × OD**
B2L 3.5	Weidmüller B2L 3.5	7	0.2 – 1	0.5 – 1.1	tension clamp connection	3 × OD**
ST/FC/LC	Bayonet/Screw/Snap Fiber Optic	-	-	-	-	30 mm
PE FASTON TERMINAL	TE Connectivity 6.3x0.8	7	min. 4	min. 2.3	-	3 × OD**

- Bend radius is measured along the inside curve of the wire or wire bundles.
- ** OD is the outer diameter of the wire or cable, including insulation.

The tightening torque of the screw for protective earth connection and the wall mounting must be approx. 5 Nm.

The tightening torque of the screw for fastening the STVS connector must be approx. 1 Nm.

The minimum distance between an EP+ device and its wire channel must be at least 3 cm.

The minimum distance between two EP+ devices must be at least 10 cm.

During the installation make sure that the shortest possible length for PE (Protective Earth) cable routing is applied.

1.2.21. Mounting methods

- Flush mounting
 - 84 HP single rack
 - 42 HP single rack
 - 42 HP double rack
 - 24 HP panel instrument case
 - Remote HMI
- Rack mounting
 - 84 HP single rack
 - 42 HP single rack
 - Remote HMI
- Semi-flush mounting
 - 84 HP single rack
 - 42 HP single rack
 - 24 HP panel instrument case
 - Remote HMI
- Wall mounting (with terminals)
 - 84 HP single rack
 - 42 HP single rack
- Din rail mounting
 - 24 HP panel instrument case
- IP54 rated mounting
 - 84 HP single rack
 - 42 HP single rack
 - 24 HP panel instrument case (original frame with additional gasket)
- Fold-down mounting (with optional terminals)
 - 84 HP single rack
 - 42 HP single rack
- No mounting
 - 84 HP single rack
 - 42 HP single rack

MOUNTING METHOD	84 HP SINGLE RACK	42 HP SINGLE RACK	42 HP DOUBLE RACK	24 HP PANEL INSTRUMENT CASE	REMOTE HMI
FLUSH MOUNTING	X	X	X	X	X
RACK MOUNTING	X	X			X
SEMI-FLUSH MOUNTING	X	X		X	X
WALL MOUNTING (WITH TERMINALS)	X	X			
DIN RAIL MOUNTING				X	
IP54 RATED MOUNTING	X	X		X*	
FOLD-DOWN MOUNTING	X	X			

**additional gasket inserted into the original front panel frame*



It is recommended to leave at least 80 mm free space for the wiring at the back of the IED in case of Flush mounting, Rack mounting, and Semi-flush mounting.

1.2.21.1. Flush mounting

Flush mounting can be used for all size of racks (84 HP, 42 HP, double 42 HP) including the 24 HP panel instrument case and the remote HMI devices. When this type of mounting alternative is used the 84 HP, 42 HP, double 42 HP and remote HMI devices have got a cover profile fit on and the 24 HP devices have got a mounting frame fit on.

The dimensions of the cut-outs for the 84 HP and 42 HP devices are also applicable for the same sized remote HMI devices.

1.2.21.1.1. Flush mounting of 84 HP and 42 HP single rack

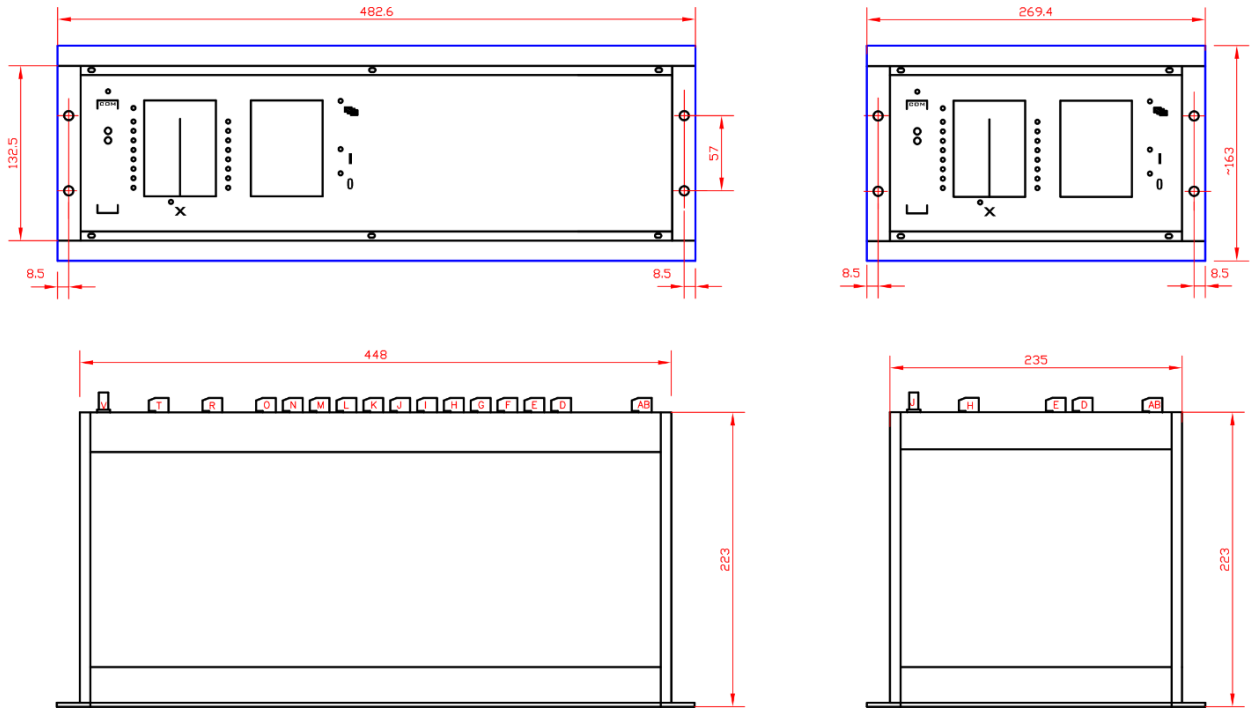

PANEL CUT-OUT

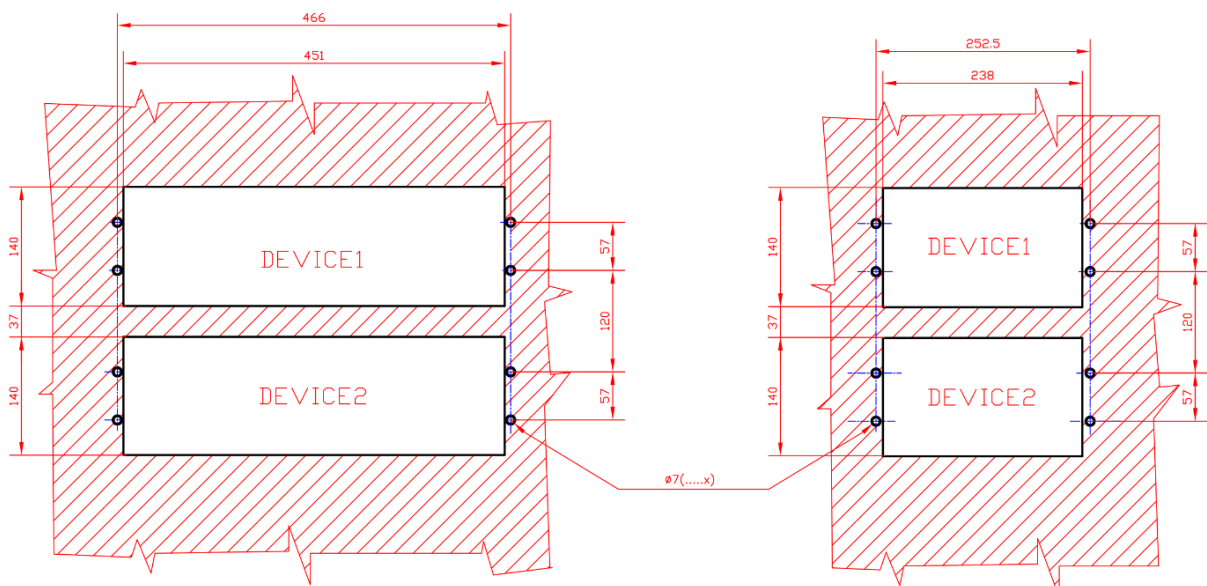

Figure 21-1 Dimensions for flush mounting of 84 HP and 42 HP single rack

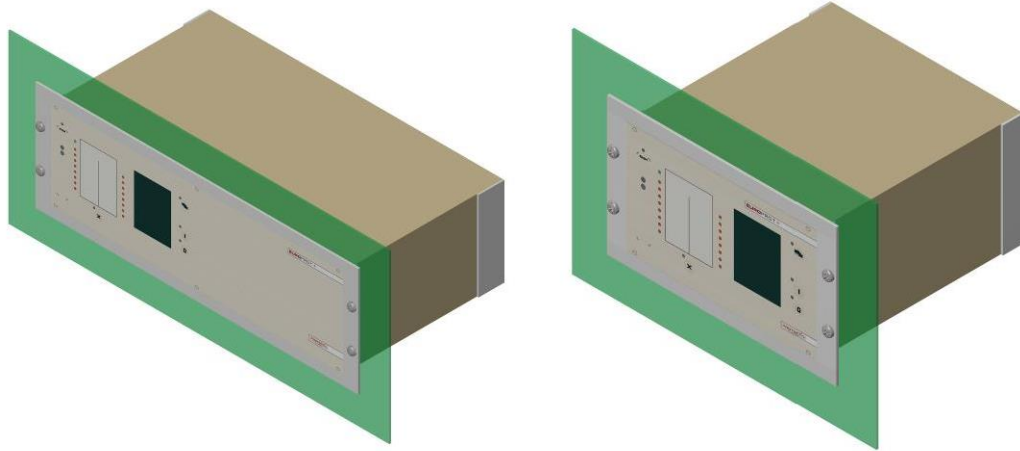

Figure 21-2 3D illustration for flush mounting of 84 HP and 42 HP devices

1.2.21.1.2. Flush mounting of 42 HP double rack

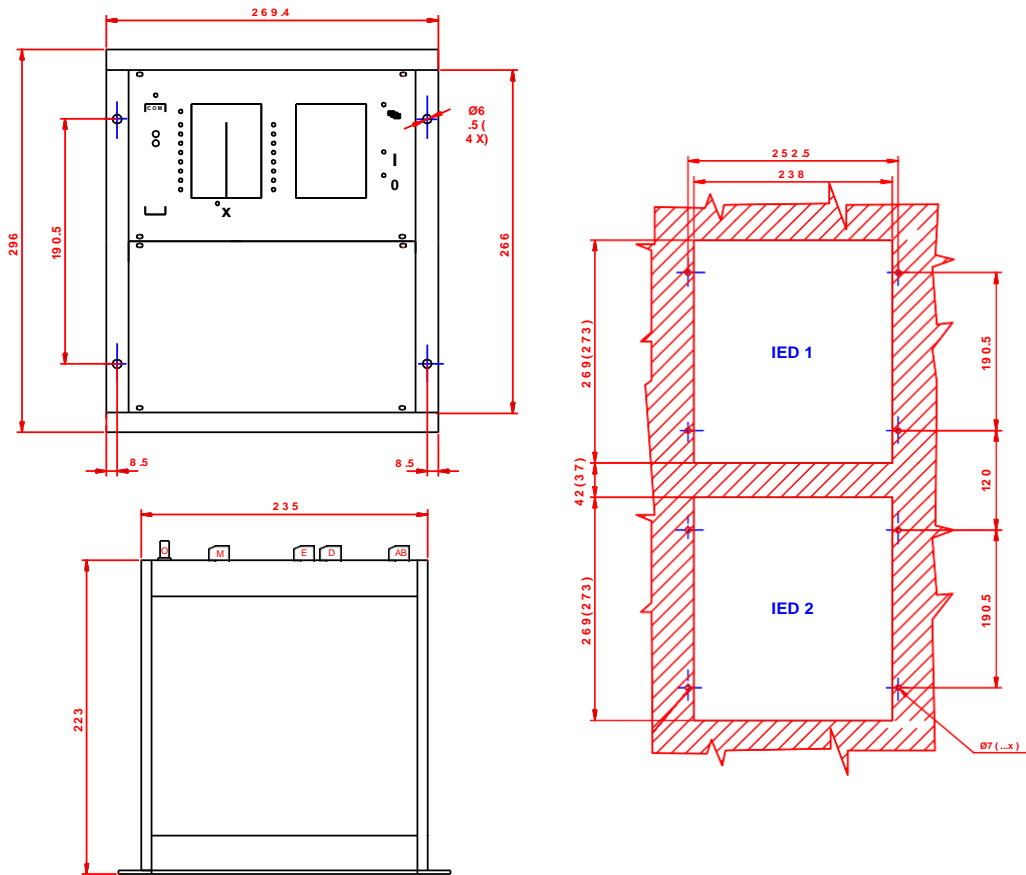

Figure 21-3 Dimensions for flush mounting of 42 HP double rack

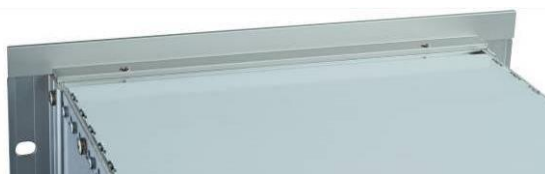

Figure 21-4 42 HP wide cover profile

1.2.21.1.3. Flush mounting of 24 HP panel instrument case

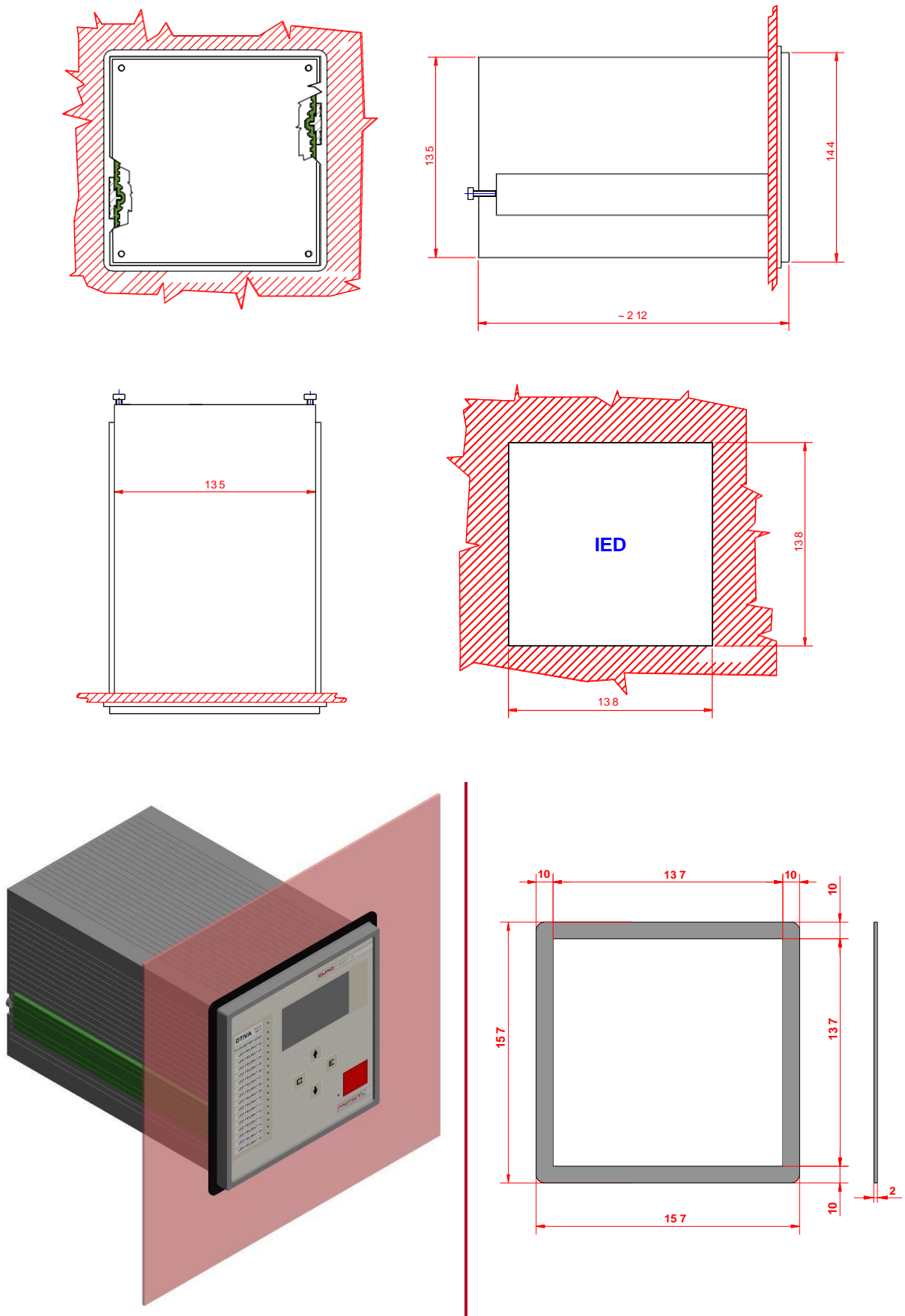

Figure 21-5 Dimensions for flush mounting of 24 HP panel instrument case with 3D illustration

1.2.21.2. Rack mounting

When rack mounting is used, the devices do not have a cover profile fit on, so it is possible to mount them in a 19" rack.

1.2.21.2.1. Rack mounting of 84 HP and 42 HP single rack

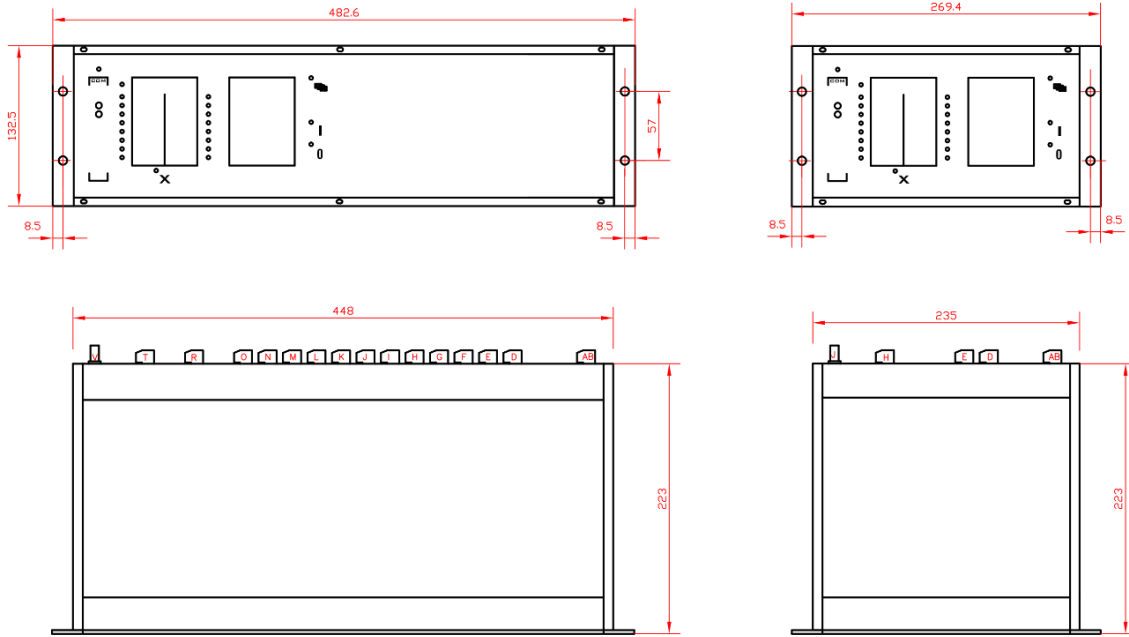

Figure 21-6 Dimensions for rack mounting of 84 HP and 42 HP single rack

Note that rack mounting type devices can also be mounted in a cut-out (e.g. on a switchgear door). It is possible to mount them from the front or from the back of the cut-out. The dimensions for rack mounting cut-outs are in the figure below. Dimensions in brackets are applicable in case of mounting from the back.

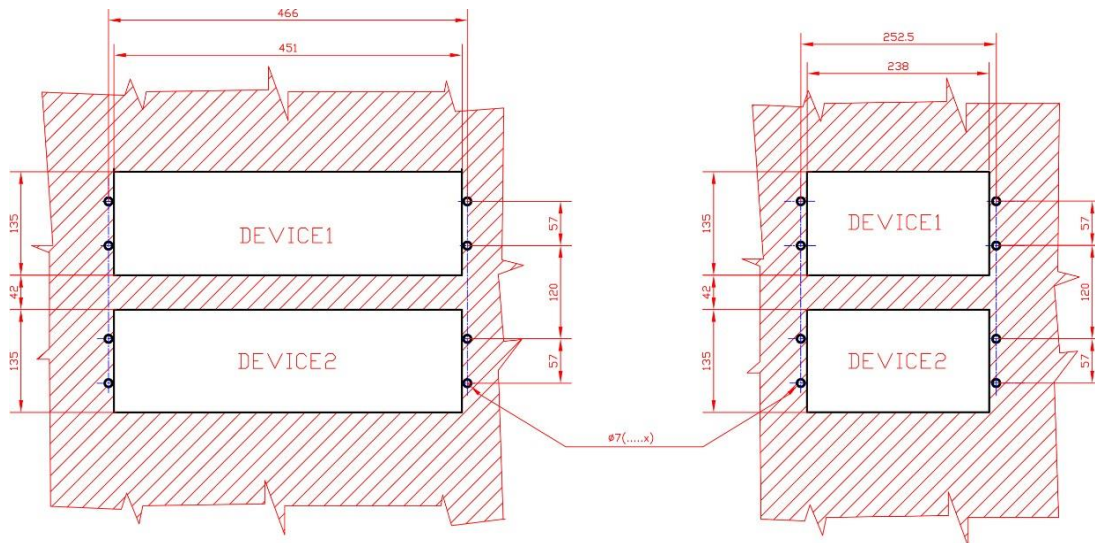
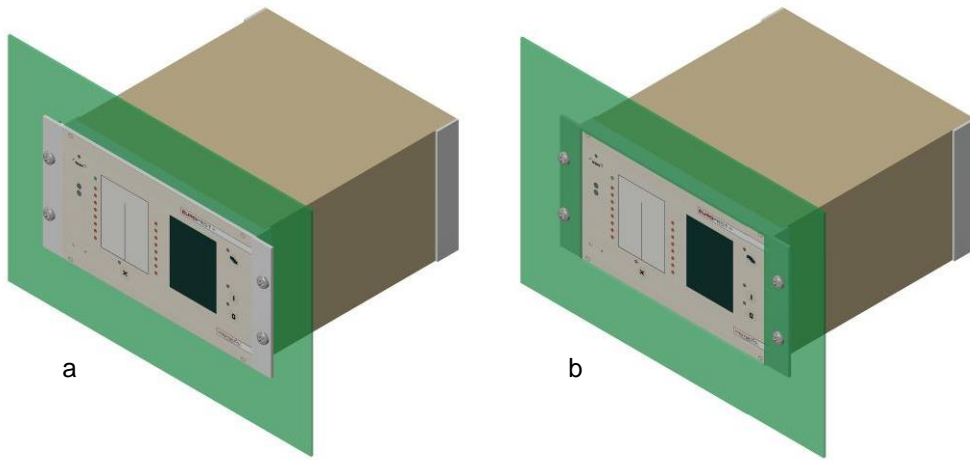
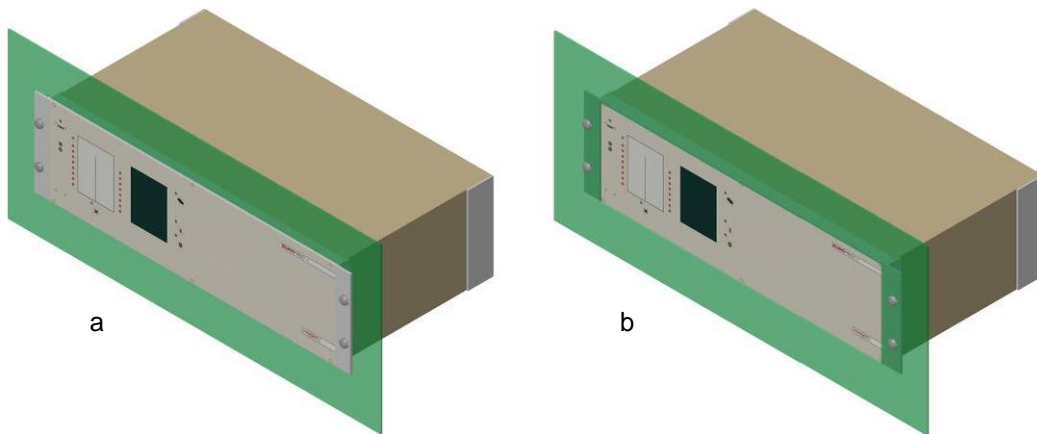

Figure 21-7 Dimensions of rack mounting cut-outs



*Figure 21-8 3D illustration for rack mounting of 42 HP device
(a - from the front; b - from the back)*



*Figure 21-9 3D illustration for rack mounting of 84 HP device
(a - from the front; b - from the back)*

1.2.21.2.2. Rack mounting of 42 HP double rack

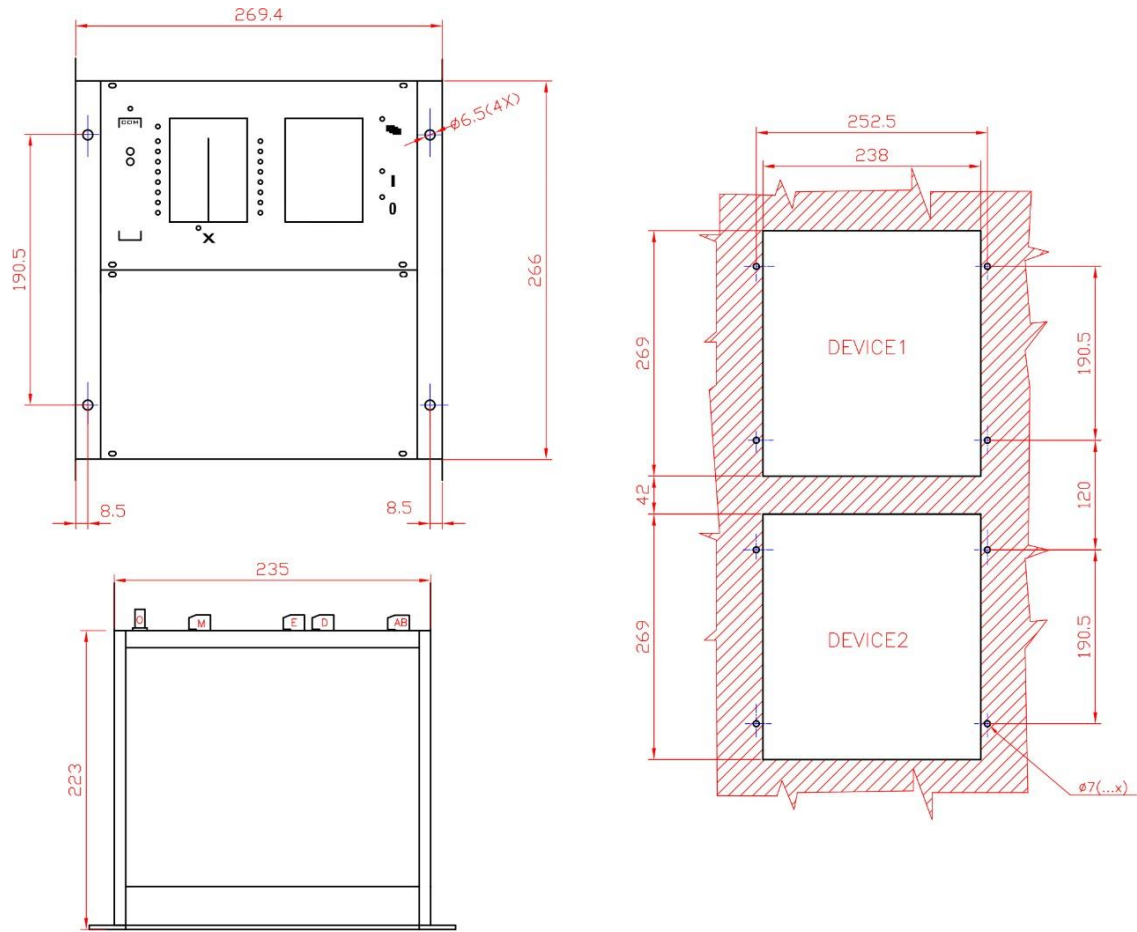

Figure 21-10 Dimensions for rack mounting of 42 HP double rack

1.2.21.3. Semi-flush mounting

Semi-flush mounting can be used for 84 HP and 42 HP single racks, for 24 HP panel instrument cases and for remote HMI devices. The purpose of this type of mounting alternative is to reduce the depth of the devices in the switchgear/rack if there is not enough space in that direction. To achieve this, a special mounting collar must be fit on the rack type devices. The default color of the mounting collar is grey (RAL 7035).

The dimensions of the special mounting collars and the cut-outs for the 84 HP and 42 HP devices are also applicable for the same sized remote HMI devices.

1.2.21.3.1. Semi-flush mounting of 84 HP single rack

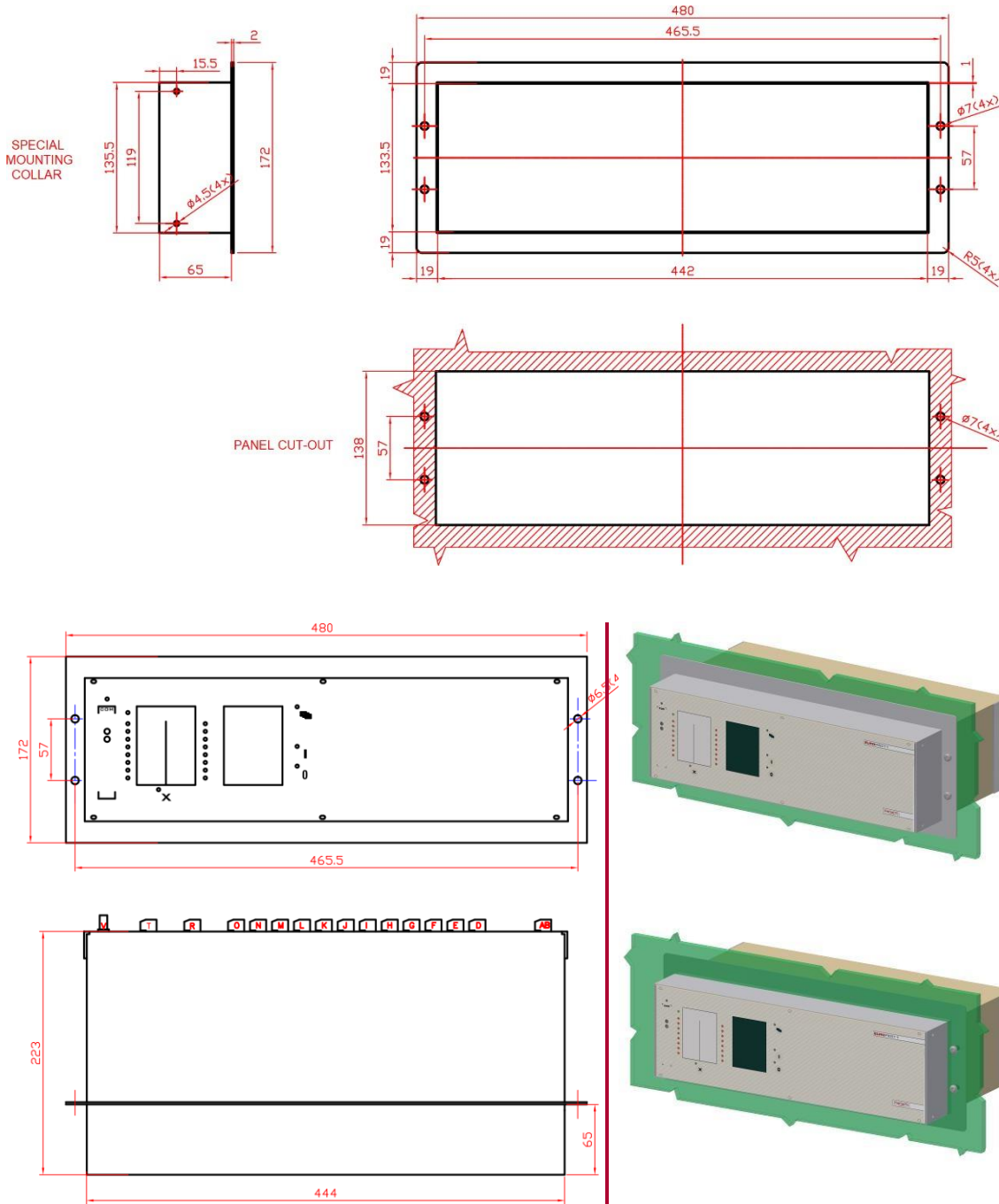

Figure 21-11 Dimensions for semi-flush mounting of 84 HP single rack with 3D illustration

1.2.21.3.2. Semi-flush mounting of 42 HP single rack

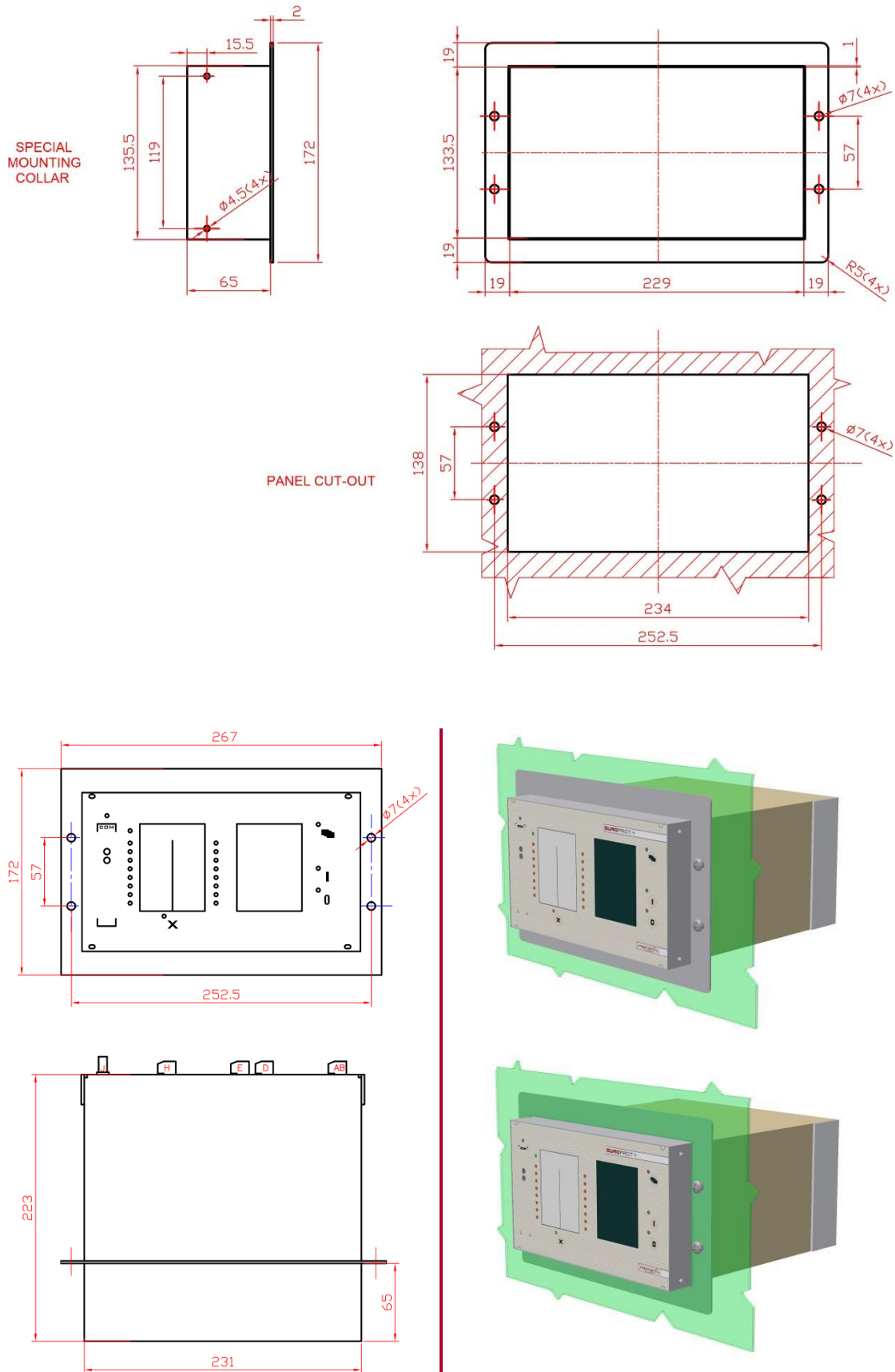

Figure 21-12 Dimensions for semi-flush mounting of 42 HP single rack with 3D illustration

1.2.21.4. Wall mounting of 42 HP and 84 HP devices

Depending on the amount of the terminal contacts, it is possible to use both upper and lower terminals.

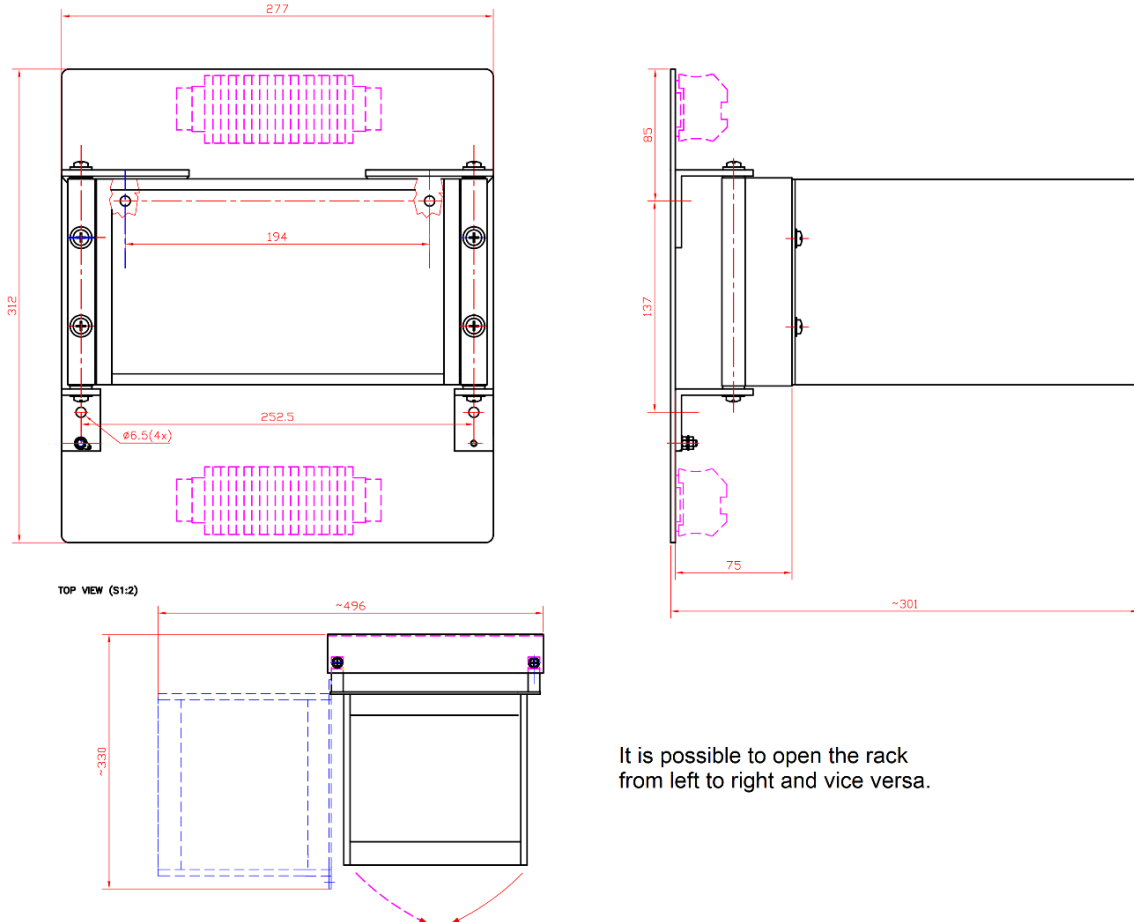

Figure 21-14 Dimensions for wall mounting of 42 HP devices (upper and lower terminals)

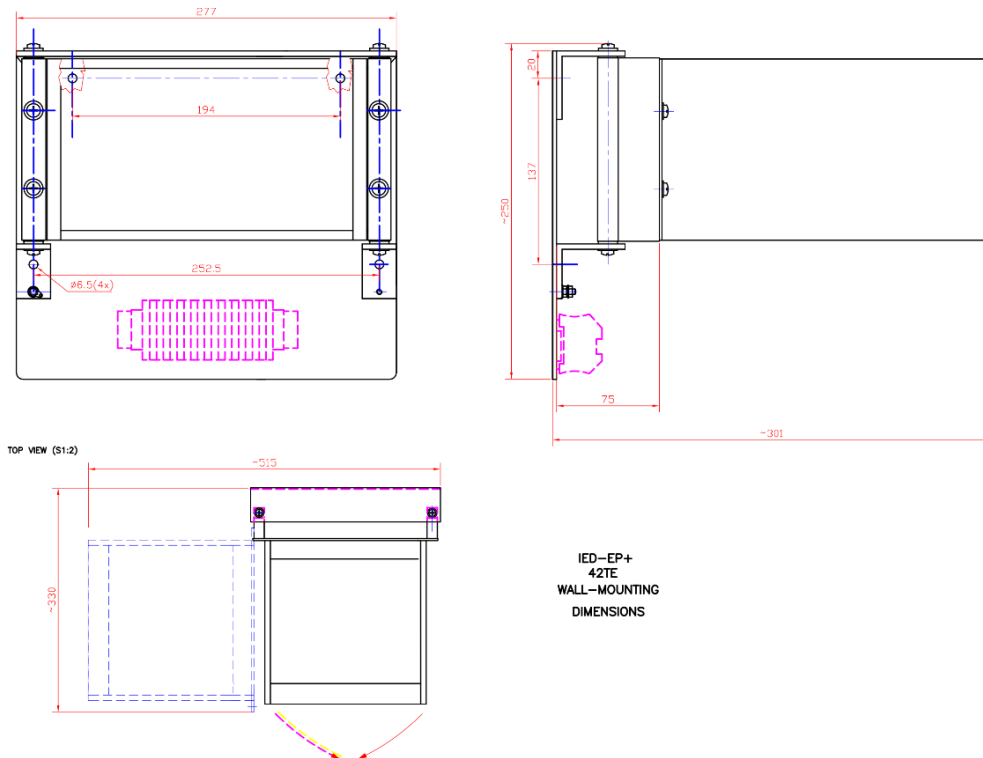

Figure 21-15 Dimensions for wall mounting of 42 HP devices (lower terminal only)

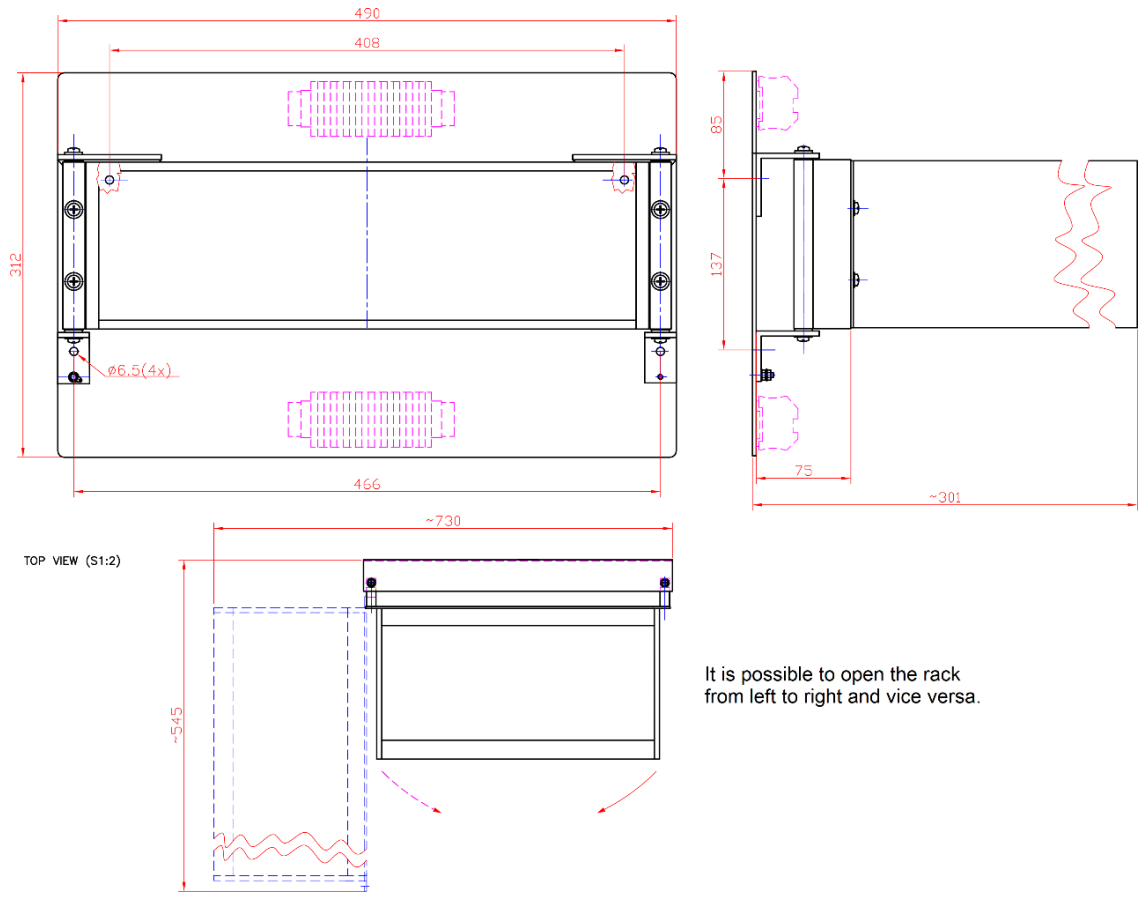

Figure 21-16 Dimensions for wall mounting of 84 HP devices (upper and lower terminals)

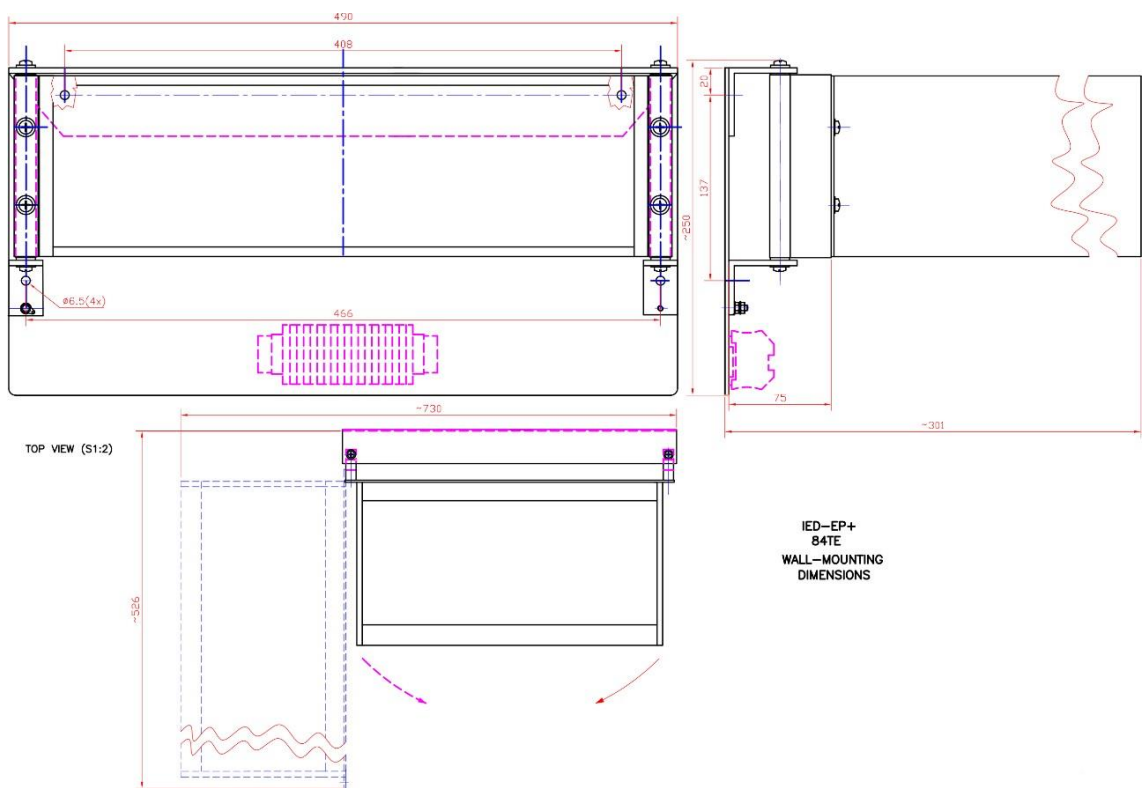

Figure 21-17 Dimensions for wall mounting of 84 HP devices (lower terminals only)

1.2.21.5. Din rail mounting of 24 HP panel instrument case

Note that the IP54 front panel option cannot be utilized with this type of mounting.

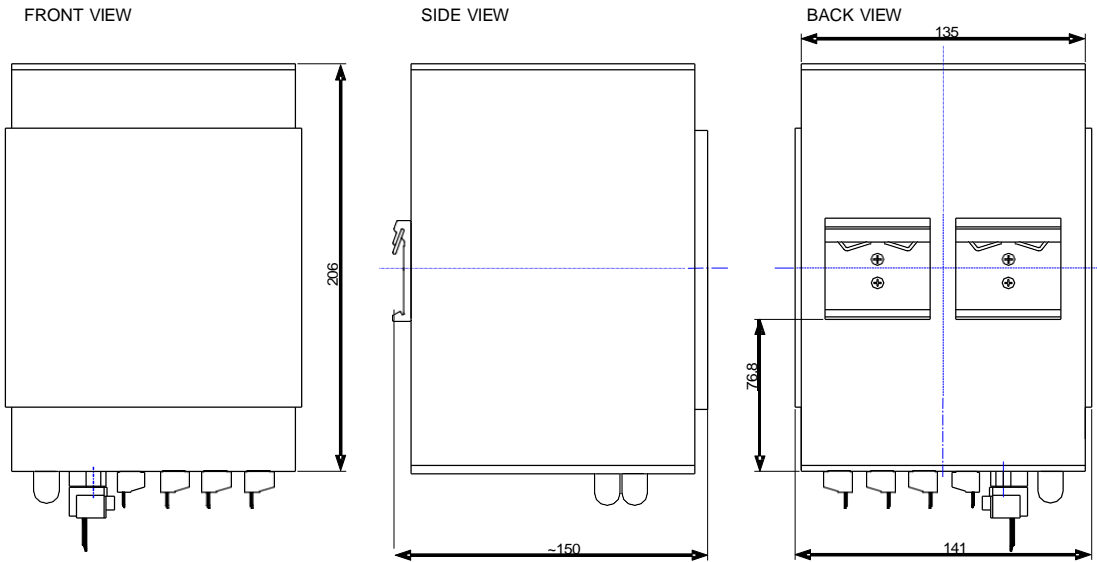

Figure 21-18 Dimensions for din rail mounting of 24 HP panel instrument case

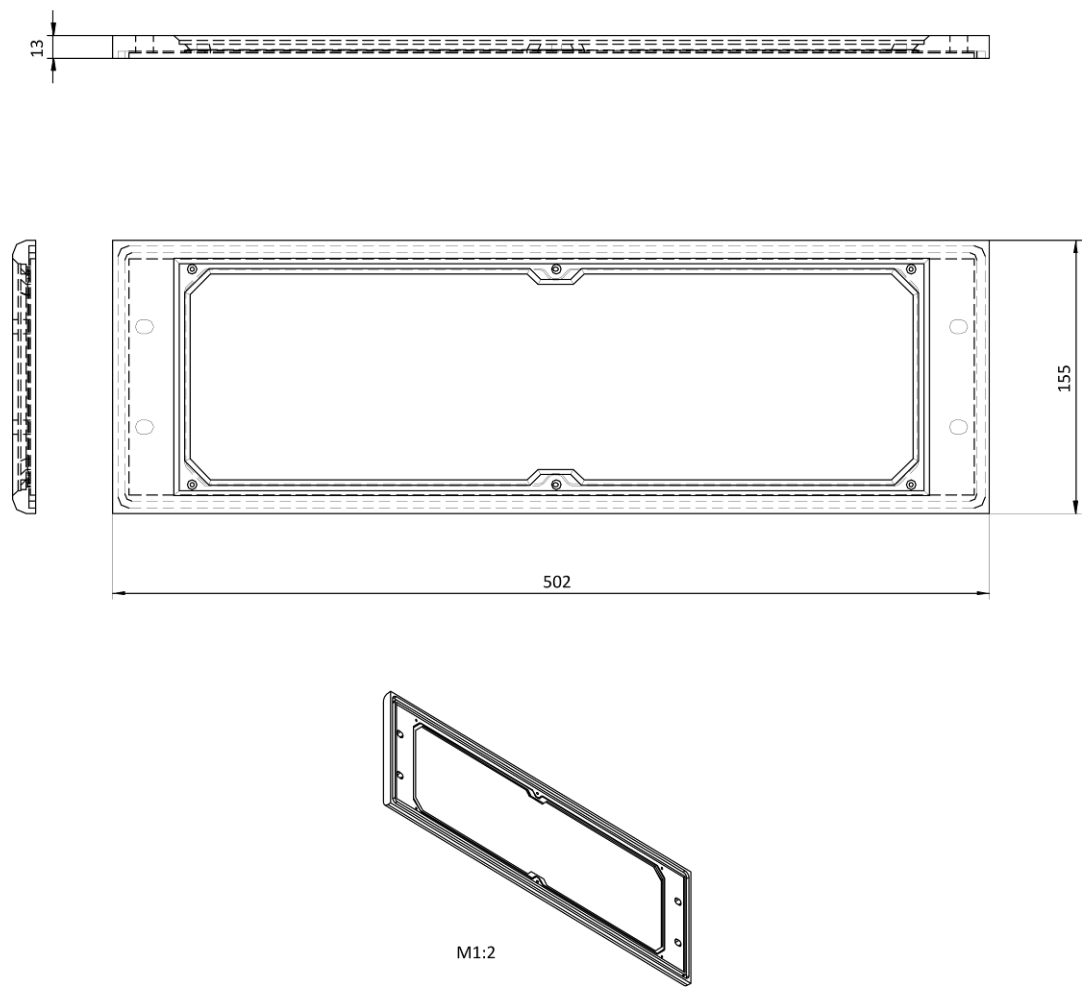

Figure 21-21: 84 HP IP frame dimensions

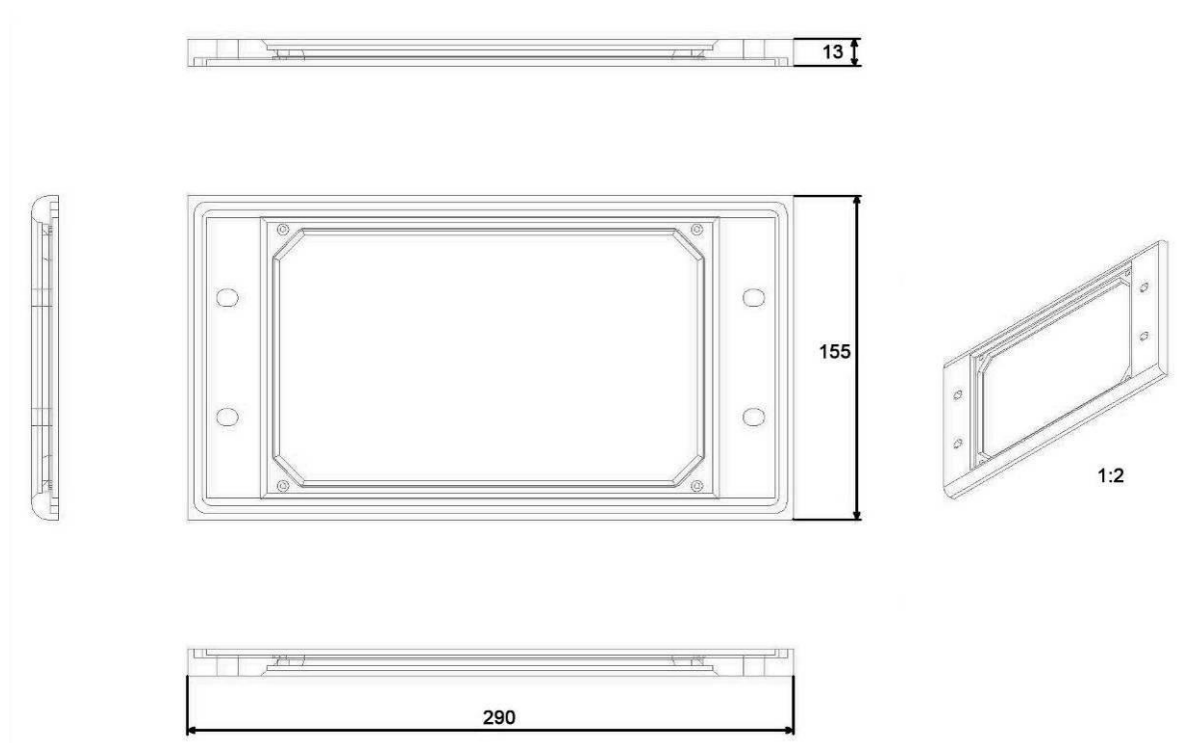

Figure 21-22 42 HP IP frame dimensions

1.2.21.7. Fold-down mounting

1.2.21.7.1. Fold-down mounting without terminals

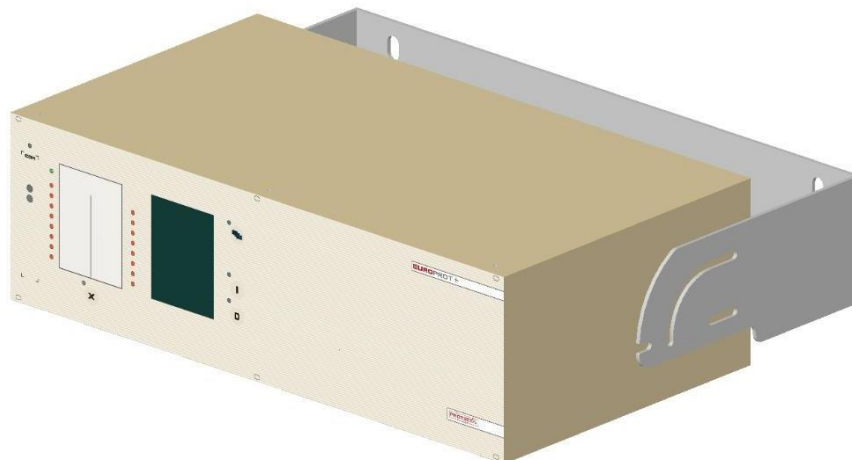
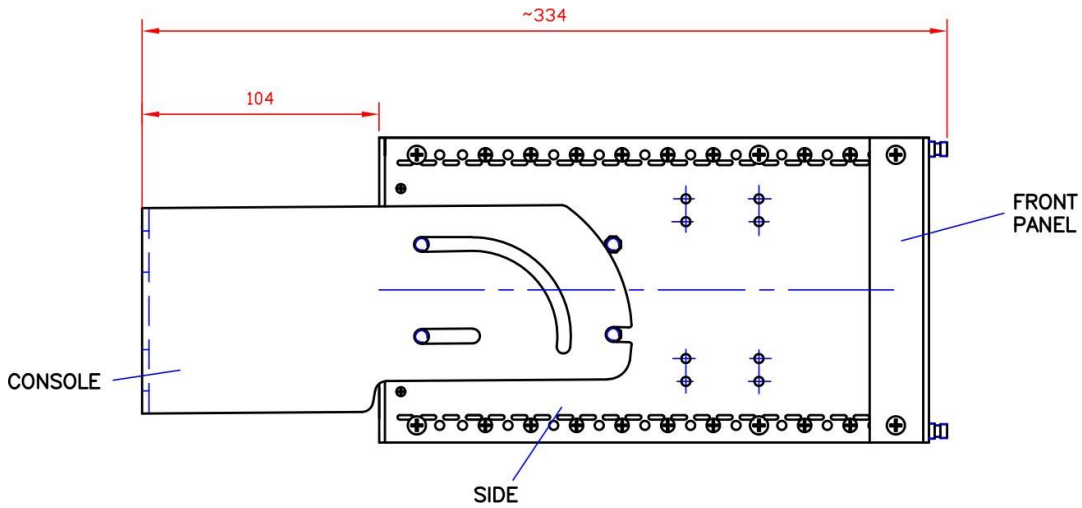
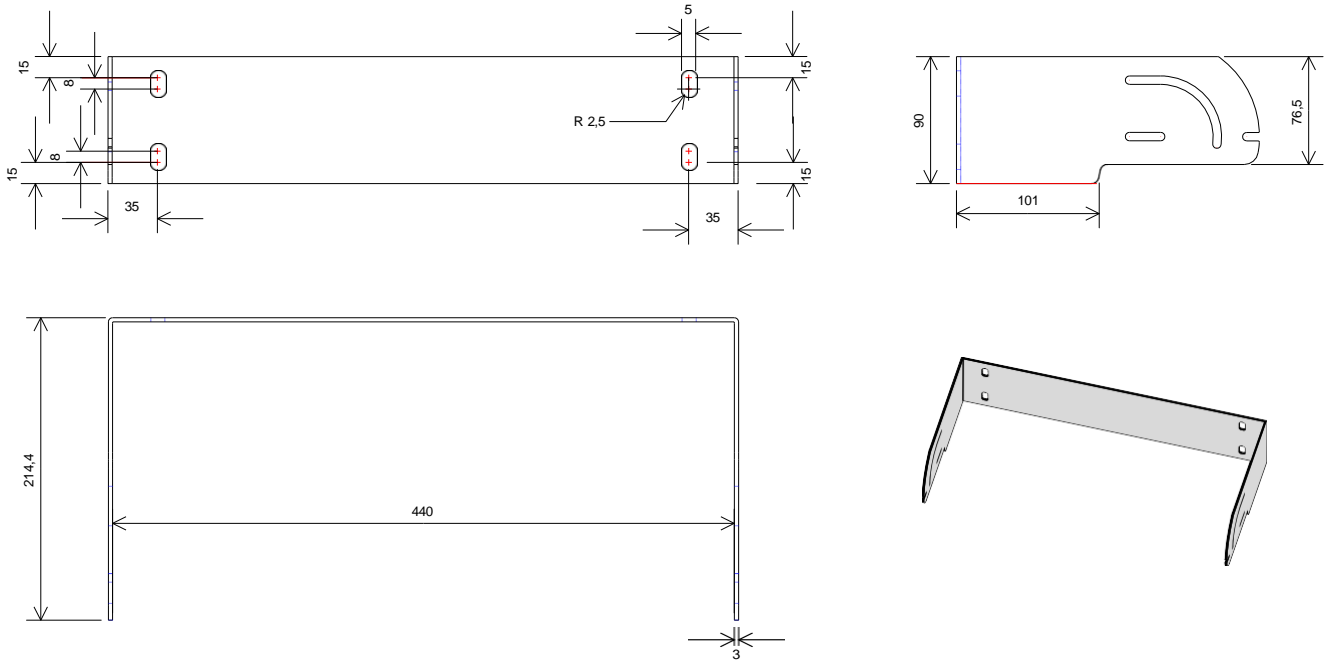

Figure 21-23 84 HP fold-down mounting

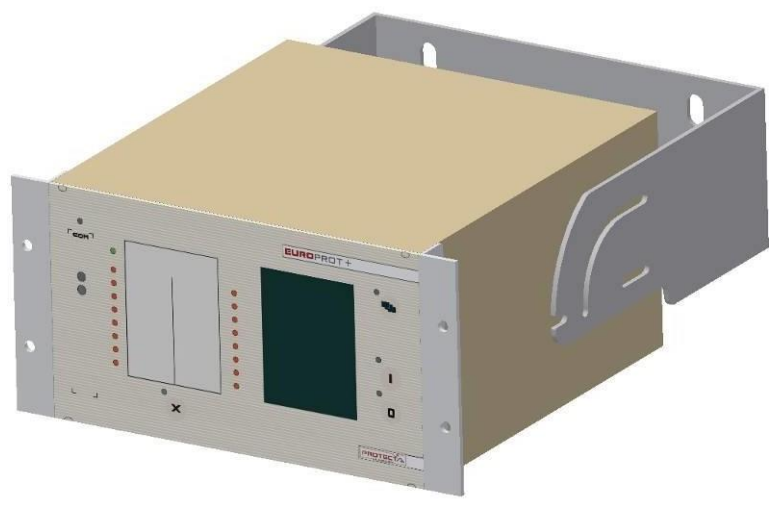
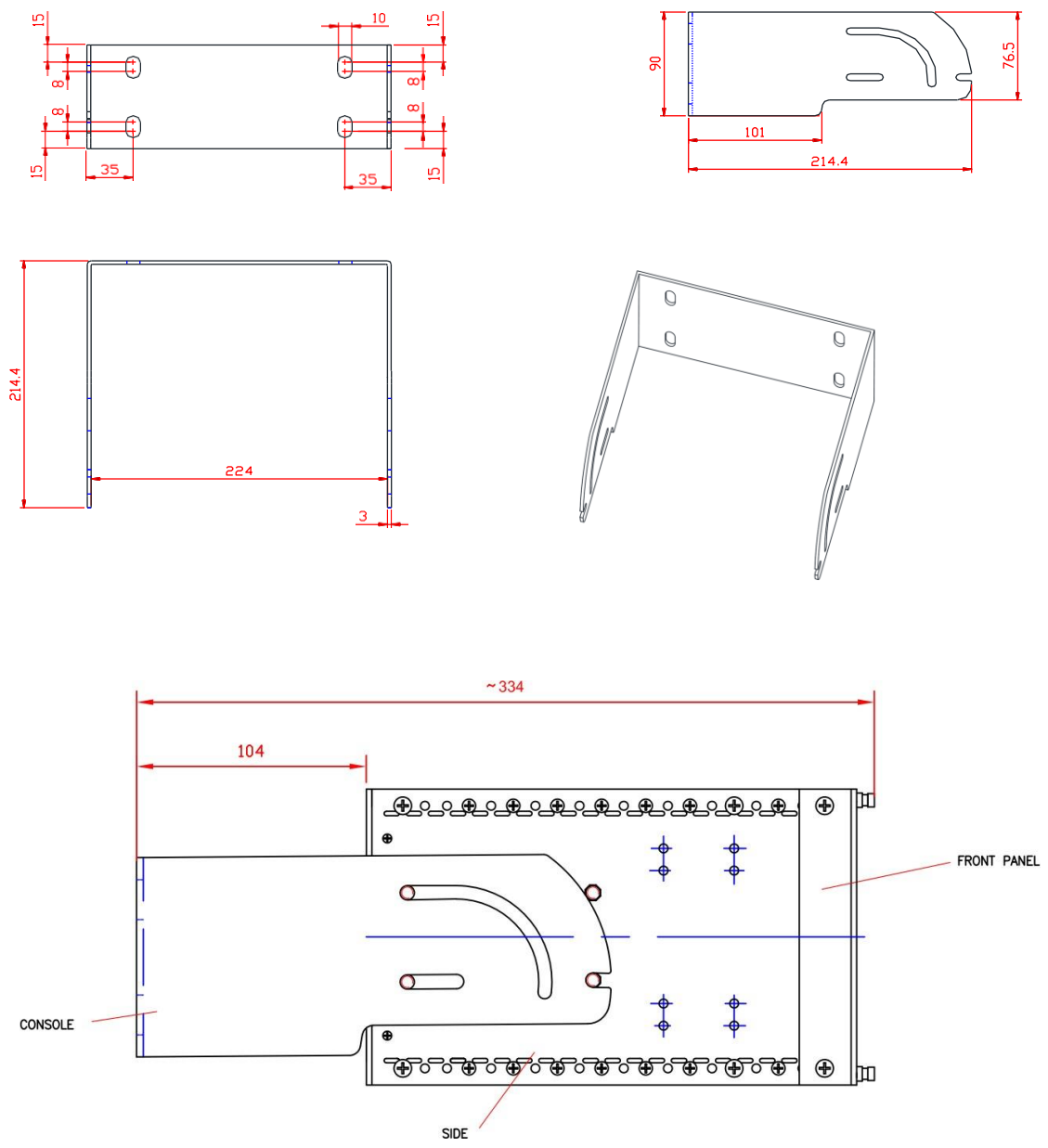

Figure 21-24 42 HP fold-down mounting

1.2.21.7.2. Fold-down mounting with terminals

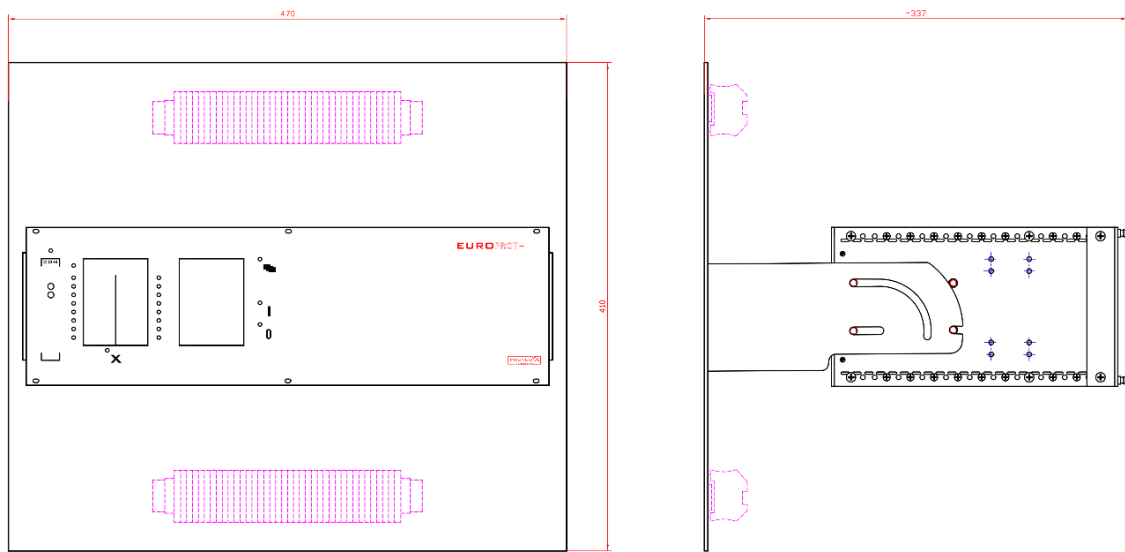

Figure 21-25 Fold-down mounting with terminals for 84HP devices

*fastening points are customized

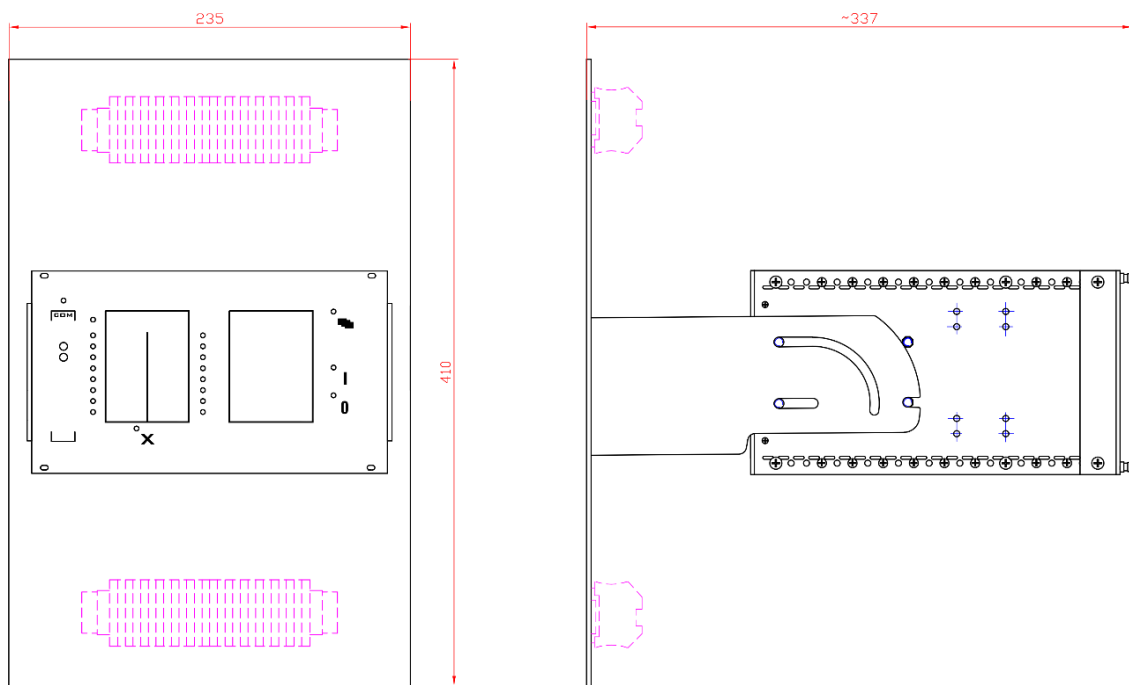
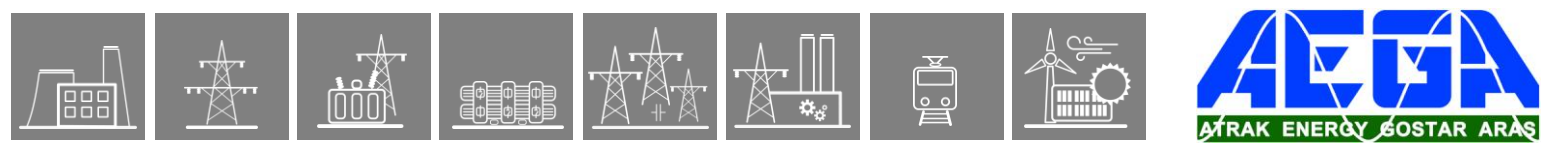

Figure 21-26 Fold-down mounting with terminals for 42HP devices



1.2.21.8. No mounting

“No mounting” means that the 84 HP and 42 HP devices do not have any mounting accessories on them.

This mounting method is only applicable if the device is for demonstration application.

For more information about this topic please contact our Application Team.
(application@protecta.hu)

IMPORTANT

The dimensions of the cut-outs applicable for the remote HMI are depending on which previously mentioned mounting method is used (flush mounting, semi-flush mounting or rack mounting).

1.2.21.9. Remote HMI devices

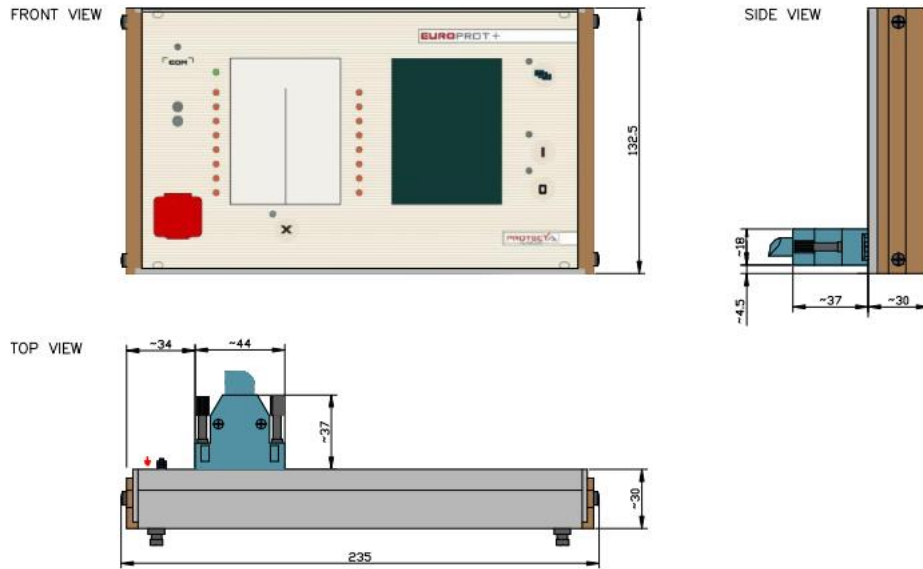
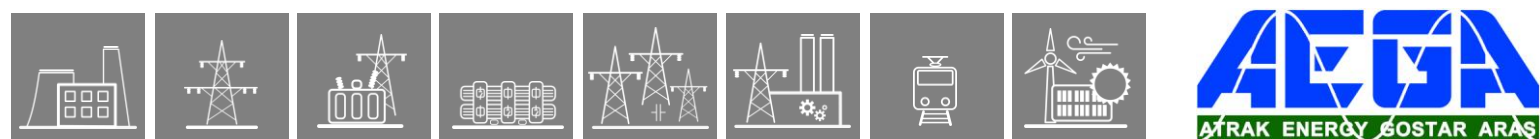

Figure 21-27 Dimensions for 42 HP wide remote HMI



Figure 21-28 Dimensions for 84 HP wide remote HMI



1.2.22. Product availability (special and obsolete modules)

In this chapter you can read a list of the modules that have not regular availability for any reason (being obsolete or being used only in special configurations).

Special modules:

These modules can be ordered in case of special applications which are indicated for each module at its description in the previous chapters.

For more information about these devices please contact our Application Team. (application@protecta.hu)

Optional connectors:

The optional connectors are indicated at each module's description in the previous chapters. If a module is to be shipped with an optional connector, the issue must be discussed during ordering.

MODULE TYPE	COMMENT	DATE
CPU+/0001	Legacy CPU card, not recommended for new configurations. Replacement: CPU+1211	2013-06-12
CPU+/0002	Legacy CPU card, not recommended for new configurations. Replacement: CPU+1111	2013-06-12
CPU+/0003	Legacy CPU card, not recommended for new configurations. Replacement: CPU+1101	2013-06-12
CPU+/0004	Legacy CPU card, not recommended for new configurations. Replacement: CPU+1201	2013-06-12
CPU+/0005	Legacy CPU card, not recommended for new configurations. Replacement: CPU+1281	2013-06-12
CPU+/0006	Legacy CPU card, not recommended for new configurations. Replacement: CPU+1381	2013-06-12
CT+/1155	Available only for special configurations.	2013-06-12
CT+/5152	Available only for OGYD bay unit configurations.	2013-06-12
VT+/2215	Available only for special configurations.	2013-06-12
O12+/2101	Available only for demonstration applications.	2013-06-12
O12+/4201	Available only for demonstration applications.	2013-06-12
R4S+/01	Available only for special configurations.	2013-06-12
R4S+/16	Available only for special configurations.	2013-06-12
TRIP+/1101	Obsolete module. Not recommended for new designs.	2013-06-12
PS+/1602	Available only for special configurations.	2013-06-12
HMI+/2401	Obsolete module. Not recommended for new designs.	2014-10-06

HMI+/2404	Smart Line S24 special selection modules.	2014-10-06
HMI+/2504	Smart Line S24 special selection modules.	2014-10-06
COM+/8882	Available only for special configurations.	2014-10-06
CT+/1111	Available only for special configurations.	2014-10-06
CT+/2500	Available only for special configurations.	2014-10-06
CT+/5153	Available only for special configurations.	2014-10-06
VT+/2212	Available only for special configurations.	2014-10-06
R8+/01	Available only for special configurations.	2014-10-06
R8+/A1	Available only for special configurations.	2014-10-06
R8+/C0	Available only for special configurations.	2014-10-06
R8+/FF	Available only for special configurations.	2014-10-06
R12+/4400	Available only for special configurations.	2014-10-06
R16+/0101	Available only for special configurations.	2014-10-06
R16+/0001	Available only for special configurations.	2014-10-06
R16+/A001	Available only for special configurations.	2014-10-06
PS+/4401	Available only for special configurations.	2014-10-06
CT+/2500	Obsolete module. Not recommended for new designs. Replacement: CT+1500.	2015-02-13
PSTP+/2102	Available only for special configurations.	2015-06-23
PSTP+/4202	Available only for special configurations.	2015-06-23
CT+/5111	Available only for special configurations.	2015-12-08
CT+/0101	Available only for special configurations. DEFL earth fault protection only.	2018-03-19
INJ+/0015	Available only for special configurations.	2018-03-19
CT+/5155	Available only for special configurations.	2018-03-26
VT+/2246	Available only for special configurations.	2018-03-26
AIC+/0201	Obsolete module. Not recommended for new designs.	2018-03-26
CT+/5111	Obsolete module. Not recommended for new designs.	2018-03-27
VS+/0031	Obsolete module. Not recommended for new designs.	2018-05-25

R1T+/0001	Available only for special configurations. DMD.	2018-10-05
CT+/5253	Available only for special configurations.	2018-10-05
42 HP housing	The length of the 42 HP box has been reduced from 242 mm to 223 mm. For more information about the previous size of the 42 HP box please see the Figure 22-1.	2018-12-18
AIC+/0200	Obsolete module. Not recommended for new designs.	2019-04-08
PS+/1030	Available only for special configurations.	2020-05-07
PS+/1060	Available only for special configurations.	2020-05-07
HMI+/5001	Obsolete module. Not recommended for new designs.	2020-06-04
HMI+/5002	Obsolete module. Not recommended for new designs.	2020-06-04
HMI+/3502 (for 42HP)	Obsolete module. Not recommended for new designs.	2020-06-04
CT+/1515	Available only for special configurations.	2020-06-04
CT+/5115	Available only for special configurations.	2020-06-04
CT+/5116	Available only for special configurations.	2020-06-04
CT+/5154	Available only for special configurations.	2020-06-04
PSF+/1001	Available only for special configurations.	2020-06-04
RTD+/0200	Available only for special configurations.	2020-06-04
RTD+/1200	Available only for special configurations.	2020-06-04
R4MC+/01	Available only for special configurations.	2020-06-04
PS+/4301	Obsolete module. Not recommended for new designs.	2020-06-04
84 HP housing	The depth of the 84 HP box has been reduced from 242 mm to 223 mm. For more information about the previous size of the 84 HP box, see the Figure 22-1.	2021-04-01
HMI+/3501	Obsolete module. Not recommended for new designs.	2021-04-20
HMI+/3502	Obsolete module. Not recommended for new designs.	2021-04-20
HMI+/5701	Obsolete module. Not recommended for new designs.	2021-04-20
HMI+/5702	Obsolete module. Not recommended for new designs.	2021-04-20
COM+/1202	Obsolete module. Not recommended for new designs.	2021-04-20
COM+/1324	Obsolete module. Not recommended for new designs.	2021-04-29
VT+/2212	Obsolete module. Not recommended for new designs.	2021-05-06
CT+/5154	Obsolete module. Not recommended for new designs.	2021-05-06
O16+/2401	Obsolete module. Not recommended for new designs.	2022-03-22
O16+/4801	Obsolete module. Not recommended for new designs.	2022-03-22



O16+/1101	Obsolete module. Not recommended for new designs.	2022-03-22
O16+/2201	Obsolete module. Not recommended for new designs.	2022-03-22

1.2.22.1. Previous 42HP and 84HP device housings

As of 2021. Q2, not only the 42HP, but the 84HP devices are shipped with shorter racks as well. Note that this is the only difference between the new and old housings. The new racks are shorter by 19 mm from the front, thus their depth is 223 mm instead of 242 mm.

The mounting methods described in Chapter 21 are valid for the previous racks as well, keeping in mind that the depth of the device is 19 mm bigger than that of the drawings. As an example, see the previous drawing of the flush mounting for 42HP and 84HP devices in Figure 22-1. As a comparison, the new, shorter rack is also drawn in **light blue**.

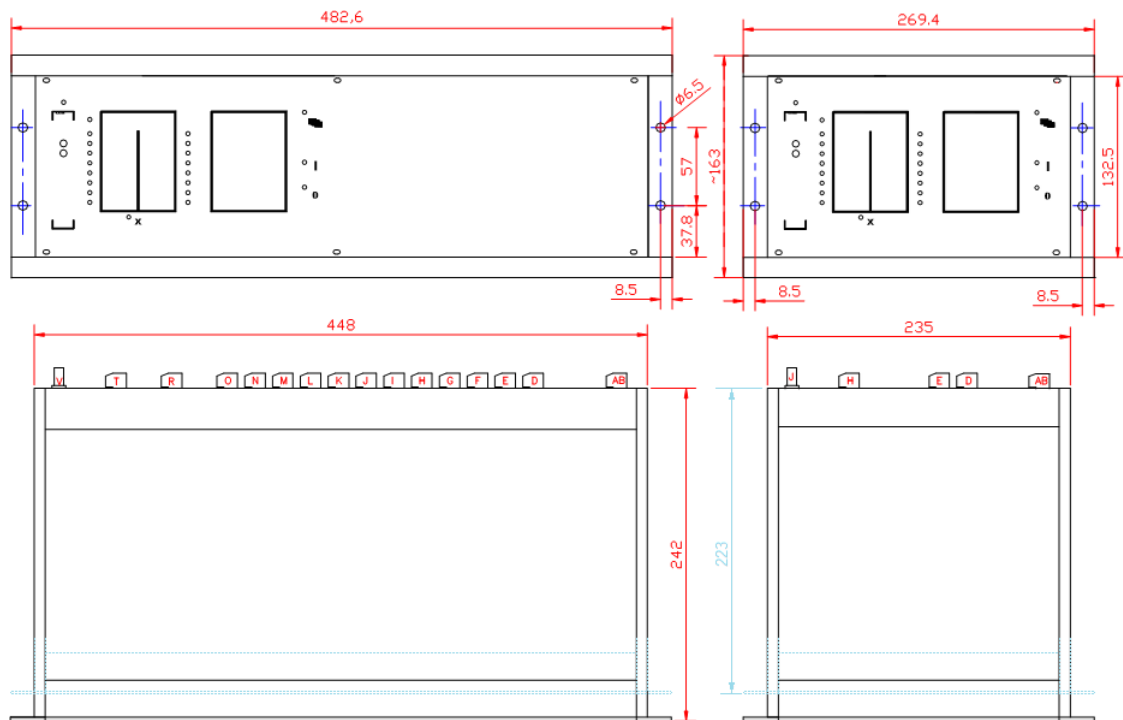

Figure 22-1 Dimensions for flush mounting of the previous 84HP and 42HP single rack, including the new (shorter) rack dimensions as well.

1.2.23. Remote I/O (RIO) server description

1.2.23.1. Introduction

Remote I/O (RIO) server is an IED, which provides remote binary inputs and outputs far from an EuroProt+ protection device.



Figure 1-1 Remote I/O device



Figure 1-2 Front view and rear view with fastening for mounting rail

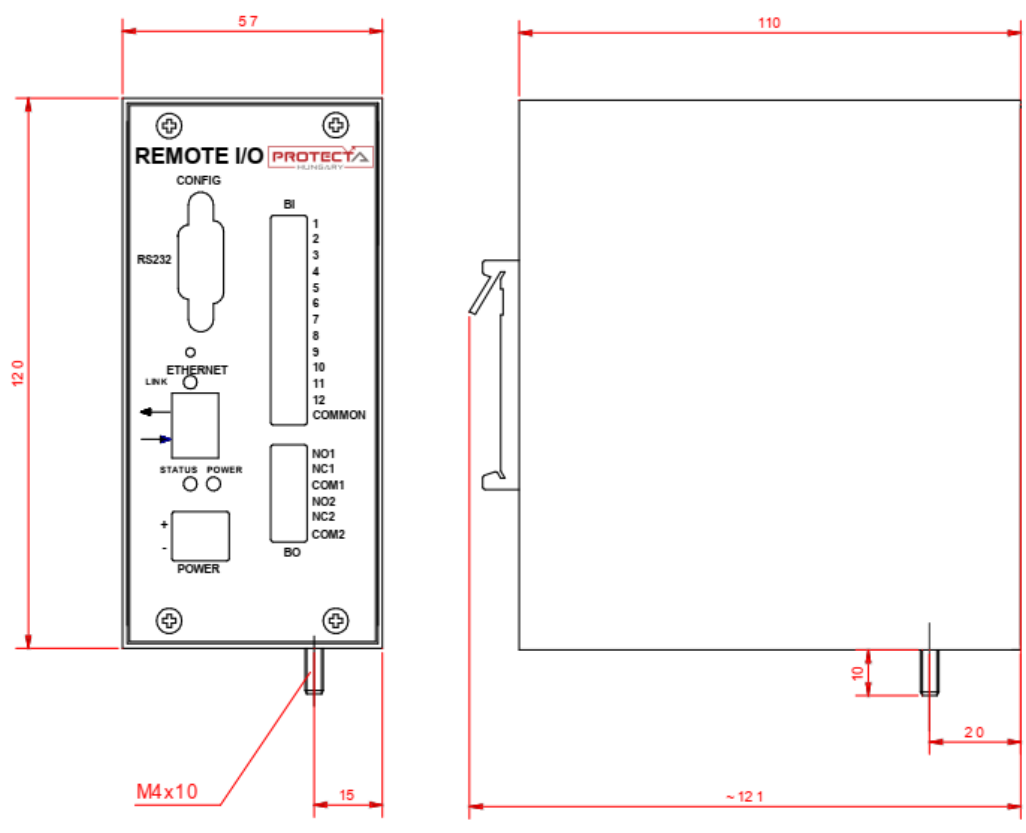

Figure 1-3 Remote I/O dimensions

1.2.23.2. Application

1.2.23.2.1. Connectors, LEDs

The connectors of the device are illustrated in the following figure.

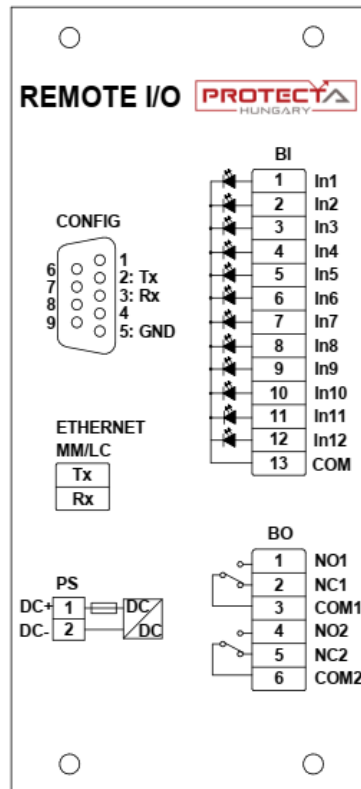

Figure 2-1 Connectors of the device

The RIO server has three LED indicators:

- **LINK:** located at the Ethernet connector; it shows active communication (green color)
- **POWER:** located above the power connector; it lights up if the device is operating (green color)
- **STATUS:** located also above the power connector. The behavior and color of this LED shows different situations:
 - Blinking **red**: there are no clients connected
 - Blinking alternatively **red-green**: the server has one client connected
 - Blinking **green**: two or more clients are connected

1.2.23.2.2. Wiring, usage

The device communicates with the EP+ device using the MODBUS/TCP protocol, via either of the COM+/1202, COM+/1324, COM+/1335, COM+/6603 or COM+/6663 modules.

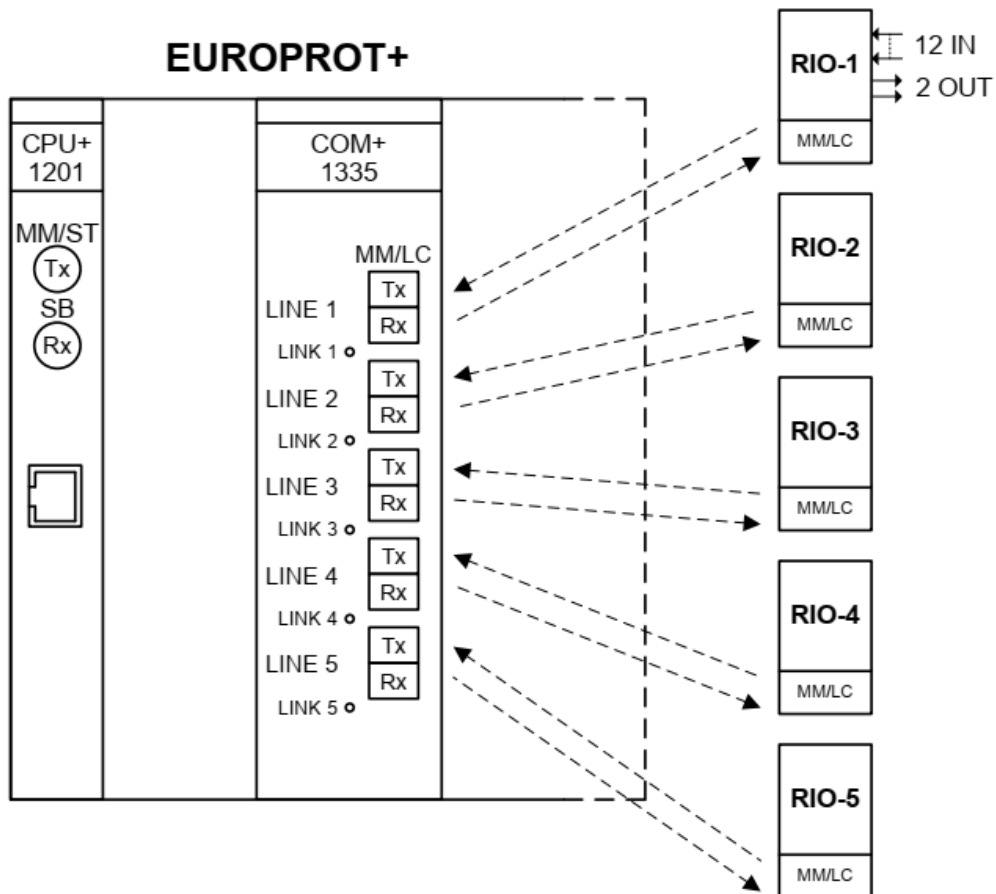

Figure 2-2 Wiring of the Remote I/O-s

The RIO inputs and outputs appear among the other binary inputs and outputs of the EuroProt+ device, and they can be utilized the same way.

1.2.23.3. Sub-modules

The RIO server consists of two mixed function modules:

- SCPU/PS: combination of a CPU and power supply module
- SO12/R2: binary I/O module with 12 inputs and 2 relay outputs

1.2.23.3.1. SCPU/PS sub-module

The SCPU/PS module contains all the control, communication and the power supply functions of the device.

1.2.23.3.1.1. CPU

Table 3-1 Technical data of the RIO CPU

CPU TYPE	ETHERNET INTERFACE	SERVICE PORT
SCPU+0011	MM/LC 1300 nm, 50/62,5/125 µm connector, 100Base-FX	RS232*

*The service port labeled "CONFIG" is only for factory usage

1.2.23.3.1.2. Power supply, external MCB

Table 3-2 Technical data of the RIO power supply

PS TYPE	INPUT VOLTAGE	NOMINAL POWER	INPUT VOLTAGE INTERRUPTION TIME	INRUSH CURRENT (< 0.1 s)	CONNECTOR TYPE
PS+1101	65-180 V DC	9 W	min. 140 ms @ 110 V DC input voltage	< 10 A	Weidmüller BLA 2/180
PS+2301	176 – 264 V DC 160 – 250 V AC	9 W	min. 50 ms @ 230 V AC input voltage	< 10 A	Weidmüller BLA 2/180

The power supply must be protected by an **external midget circuit breaker**. Note that it is not part of the RIO device:

- Characteristics: **6A C**

1.2.23.3.2. SO12/R2 sub-module

The SO12/R2 module contains 12 binary inputs in one grounding group, and 2 relay outputs with dry contacts.

1.2.23.3.2.1. Binary inputs

Main features:

- Digitally filtered per channel
- Current drain approx.: 2 mA per channel

Table 3-3 Technical data of the binary inputs

BI TYPE	CHANNEL NUMBER	TIME SYNC.	RATED VOLTAGE	THERMAL WITHSTAND VOLTAGE	CLAMP VOLTAGE	CONNECTOR TYPE
SO12+4801	12	-	48 V	72 V	falling $0.71 U_N$ rising $0.76 U_N$	Weidmüller BL 3.5/13/180
SO12+1101	12	-	110 V	250 V	falling $0.7 U_N$ rising $0.73 U_N$	Weidmüller BL 3.5/13/180

Thermal withstand voltage: continuous with 60 % of the input channels energized.

1.2.23.3.2.2. Binary outputs

Main features:

- Breaking capacity, (L/R = 40 ms) at 220 V DC: 0.2 A
- Breaking capacity, (L/R = 40 ms) at 110 V DC: 0.3 A

Table 3-4 Technical data of the relay outputs

BO TYPE	RATED VOLTAGE	CONTINUOUS CARRY	CONTACT VERSIONS	GROUP ISOLATION	CONNECTOR TYPE
R2+0001	250 V AC/DC	6 A	CO	2 independent	Weidmüller BL 3.5/6/180



1.2.23.4. General data

- Storage temperature: - 40 °C ... + 70 °C
- Operation temperature: - 20 °C ... + 55 °C
- Humidity: 10 % ... 93 %
- Altitude: up to 2000 m
- Atmospheric pressure: 86 ... 106 kPa

1.2.23.4.1. Standard conformance

- Electrostatic discharge immunity (ESD), IEC-EN 60255-26:2013, Level 4
 - Test voltages: 15 kV air discharge, 8 kV contact discharge
- Radiated, radio-frequency, electromagnetic field immunity, IEC-EN 60255-26:2013 Level 3
 - Test field strength: 10 V/m
- Electrical fast transient/burst immunity (EFT/B), IEC-EN 60255-26:2013, Level 4
 - Test voltage: 4 kV
- Surge immunity test, IEC-EN 60255-26:2013
 - Test voltages: 2 kV line-to-earth, 1 kV line-to-line
- Immunity to conducted disturbances, induced by radio-frequency fields, IEC-EN 60255-26:2013, Level 3
 - Test voltage: 10 V
- Damped oscillatory wave immunity test, IEC-EN 60255-26:2013
 - Test frequency: 1 MHz
 - Test voltage: 2.5 kV in common mode, 1 kV in differential mode
- Voltage dips, short interruptions and voltage variations immunity, IEC-EN 60255-26:2013
 - Voltage dips: 40 % (200 ms), 70 % (500 ms), 80 % (5000 ms)
- Ripple on d.c. input power port immunity, IEC-EN 60255-26:2013
 - Level 4, 15 % of rated d.c. value
- Power frequency magnetic field immunity test, IEC-EN 60255-26:2013, Level 5
 - Test field strength: 100 A/m continuous, 1000 A/m for 3 s
- Power frequency immunity test on the binary inputs, IEC-EN 60255-26:2013, Class A
 - Test voltages: 300 V in common mode, 150 V in differential mode
- Insulation tests, IEC-EN 60255-27:2013
 - Impulse voltage test
 - Test levels: 5 kV (1 kV for transducer and temperature measuring inputs)
 - Dielectric test
 - Test levels: 2 kV AC 50 Hz (0.705 kV DC for transducer inputs)
 - Insulation resistance
 - Insulation resistance > 15 GΩ
- Radiated emission, IEC-EN 60255-26:2013

Limits:

 - 30 MHz to 230 MHz: 50 dB(μV/m) quasi peak, 3 m
 - 230 MHz to 1 000 MHz: 57 dB(μV/m) quasi peak, 3 m
 - 1 GHz to 3 GHz: 76 dB(μV/m) peak, 3 m
 - 3 GHz to 6 GHz: 80 dB(μV/m) peak, 3 m
- Conducted emission, IEC-EN 60255-26:2013

Limits:

 - 0,15 MHz to 0,50 MHz: 79 dB(μV) quasi peak, 66 dB(μV) average
 - 0,5 MHz - 30 MHz: 73 dB(μV) quasi peak, 60 dB(μV) average
- Vibration, shock, bump and seismic tests on measuring relays and protection equipment
 - Vibration tests (sinusoidal), Class I, IEC 60255-21-1:1988
 - Shock and bump tests, Class I, IEC 60255-21-2:1988
 - Seismic tests, Class I, IEC 60255-21-3:1993

1.2.23.5. Mechanical data

1.2.23.5.1. General mechanical data

- Construction
 - Painted steel surface
- IP protection:
 - IP2x
- Size:
 - See Figure 1-3 for the device dimensions
- Weight:
 - 0.7 kg

1.2.23.5.2. Connectors

Table 5-1 Connectors on the RIO

CONNECTOR NAME	CONNECTOR TYPE	STRIP LENGTH [MM]	CONDUCTOR AREA [MM ²]	CONDUCTOR DIAMETER [MM]	TIGHTENING TORQUE [Nm]	MINIMUM BEND RADIUS*
BLA	Weidmüller BLA 2/180	7	0.2 – 1.5 solid: 0.2 – 2.5	0.5 – 1.4 solid: 0.5 – 1.8	0.4 – 0.5	3 × OD**
BL 3.5	Weidmüller BL 3.5/6/180 BL 3.5/13/180	6	0.2 – 1.5	0.5 – 1.4	0.2 – 0.25	3 × OD**
PE FASTON TERMINAL	TE Connectivity 6.3x0.8	7	min. 4	min. 2.3	-	3 × OD**

* Bend radius is measured along the inside curve of the wire or wire bundles.

** OD is the outer diameter of the wire or cable, including insulation.

The tightening torque of the screw for protective earth connection must be approx. 5 Nm.

During the installation, make sure that the shortest possible length for PE (Protective Earth) cable.

The minimum distance between the device and its wire channel must be at least 3 cm.

1.2.24. Technical notes on EOB interoperability

1.2.24.1. Description

We experienced some interoperability issues regarding front panel communication with EP+ devices. The link establishment procedure of the ethernet communication become unstable with certain type of NICs (Network Interface Card) of network devices. Network devices with 10/100Base-T speed support has no limitation but devices with 1000Base-T (called gigabit) may cause this link establishment failure. In this case the operating system periodically signals that interface is connected, then disconnected, then connected etc.

1.2.24.2. EOB Troubleshooting

- force NIC speed and mode to 10Base-T Full-duplex (setting method may depend on Your PC hardware configuration) on Your PC. Local Area Network settings can be found at:
 - WindowsXP: Control Panel/Network Connections/Local Area Connection
 - Windows 7: Control Panel\All Control Panel Items\Network and Sharing Center

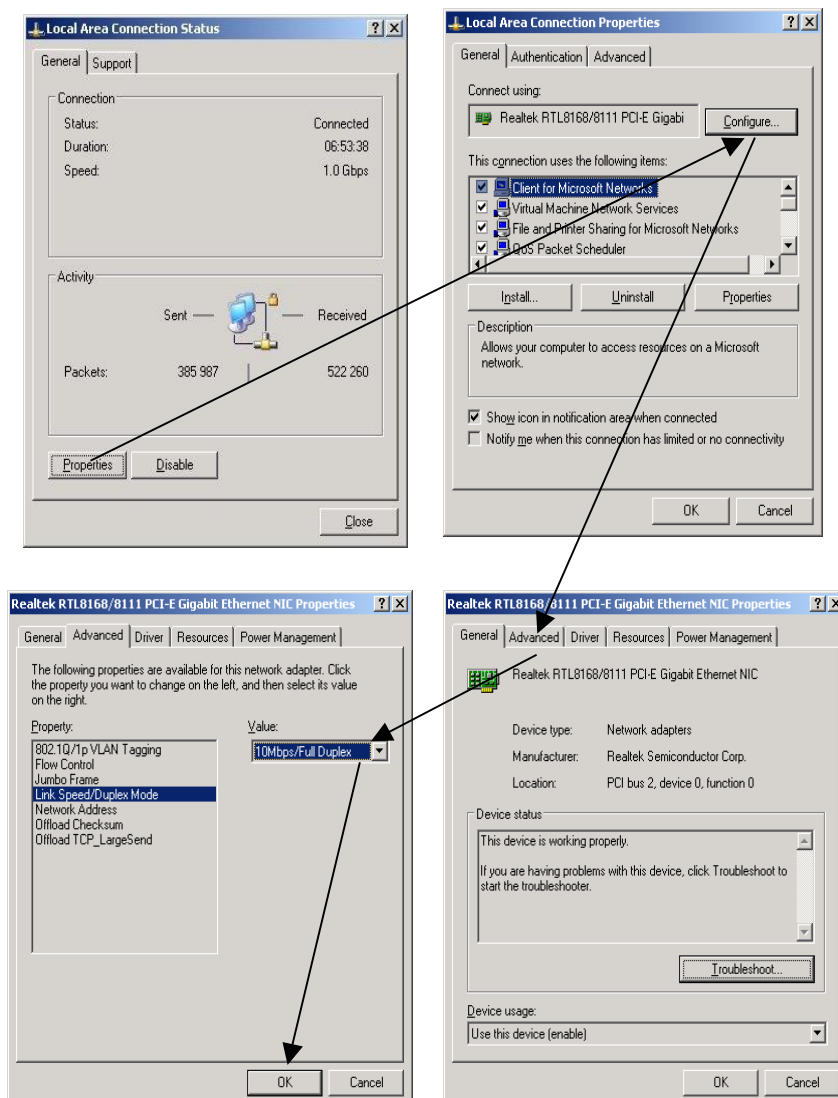

1.2.24.3. Workaround

- using station bus interface connector at the front panel of the CPU card
- if the device equipped with 100Base-Fx station bus interface then You can connect Your computer via a third-party media converter unit
- if the device equipped with 10/100Base-Tx station bus interface (RJ45) then connect Your computer directly to the EP+ via a crossed CATx cable

Service computer

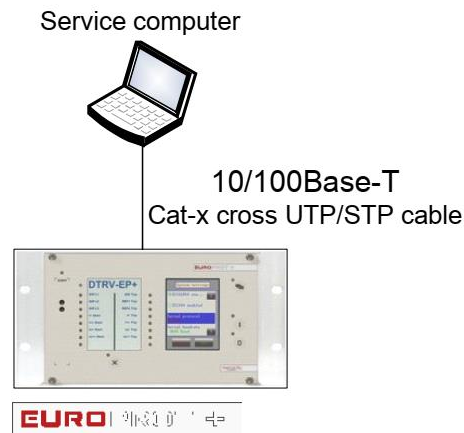

- using EOB at the HMI:
 - in case of unstable link with Your PC apply a third-party external 10/100Base-T switch with one port connected via EOB to the EP+ and other port connected to Your PC via a CATx cable.

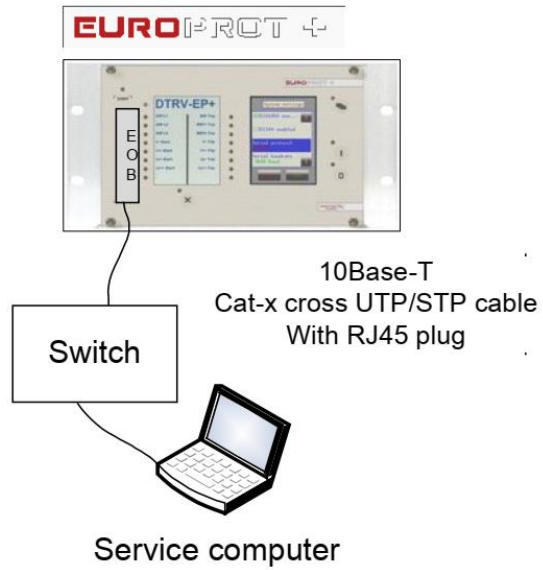

1.2.24.4. Further details

For getting started guide and IP configuration download: http://www.protecta.hu/epp-prelim/QuickStart/Quick_Start_Guide_V1.0.pdf

1.2.25. EP+ Installation manual

USED SYMBOLS

Symbols on devices:



Test voltage: 2 kV



Protective conductor terminal



Do not dispose of this device

Symbols in this document:



Caution, risk of electric shock



Caution, hot surface



Caution, refer to the documentation



Do not dispose of this device



1.2.25.1. Introduction

This manual is intended to provide instruction for proper device installation, which includes mechanical mounting and electrical wiring. Furthermore, the information provided here will strongly support commissioning, maintenance, and deinstallation work as well. This document's targeted user groups are skilled electrical professionals executing installation works and commissioning with EuroProt+ devices.

Given that the EuroProt+ product family has a modular design, the instructions provided here can cover all configurations. Therefore, this manual shall be used in conjunction with the "EuroProt+ Hardware description" document, which includes essential information about all hardware components of the product.

1.2.25.2. Equipment handling

1.2.25.2.1. Unpacking

Inspect the package for transport damages. Carefully remove the packing material without applying excessive force.

1.2.25.2.2. Visual inspection

Identify the product by reading the order code. This can be found on the device nameplate located mostly on the right side of the device in the top right corner and shall be identical to your order.

Picture 2-2 Device nameplate



The protection device may have loose items packed in a different box based on the configuration. Check, that these items are also included in the shipment.

Visually inspect all unpacked items for damages, water ingress, or any sign of external impact. If you discover any transport damage, please notify Protecta Ltd. first and do not start any further work on the equipment.

1.2.25.2.3. Storage

If temporary storage is required before installation, please store the device in its original packing in a dry and clean place. The required environmental conditions can be found in the “General data” section of the “EuroProt+ Hardware description” document.

1.2.25.3. Mounting

1.2.25.3.1. Tools for mounting

The tools and screws necessary for mounting depend on the method of the mounting, see the “Mounting methods” section of the “EuroProt+ Hardware description” document.

Assuming the panel or cubicle is ready for installation of the device, screwdrivers matching the screws used, pliers, wrenches, etc. are necessary. For safety aspects, mechanical protective gloves shall be used to avoid injuries.

1.2.25.3.2. Environmental conditions

Make sure, that the mounting location fulfils environment requirements stated in the “General data” section of the “EuroProt+ Hardware description” document. The IP protection class of the device shall fit the surrounding environment at the place of installation. It is also important to have space around the device to support conventional cooling (See 3.3).

1.2.25.3.3. Mounting location

Before mounting the device make sure, that suitable space is available in the location of installation. Cutouts shall fit the device rack dimensions and it is recommended to leave 80mm free space behind the IED for the wiring.

The minimum distance between an EP+ device and its wire channel must be at least 3 cm. The minimum distance between two EP+ devices must be at least 10 cm.

1.2.25.3.4. Mounting the device

The EuroProt+ product line utilizes different rack sizes and depending on that different mounting methods. An overview of the rack sizes with dimensions and mounting methods can be found in the “Mounting methods” section of the “EuroProt+ Hardware description” document.

During the installation make sure that the shortest possible length for PE (Protective Earth) cable routing is applied.

1.2.25.3.5. Safety aspects

1.2.25.3.5.1. Earth connections

1.2.25.3.5.1.1. Protective earth

The device shall be connected to the station earth system with a minimum of 2,5 mm² cross-section solid or stranded wire. A 6,3 mm (1/4 inch) female flat connector (according to IEC 61210) shall be used crimped to the earthing wire. During the installation make sure that the shortest possible length for PE (Protective Earth) cable routing is applied.

The earth connection of the device is situated at all kinds of Power supply modules. In the case of more Power supply modules, all of them shall be earthed.

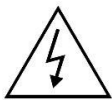

The protective earth connections should not be removed when the equipment is energized.

Picture 3-5-1-1 Earth connection point of the device at the Power supply module



1.2.25.3.5.1.2. Stranded wires

Soft soldering of stranded wires is not allowed due to the cold flow of the solder material.



Loose strands of stranded wires can cause fire risk or electric shock. Insulated crimp terminals shall be used.

1.2.25.3.5.1.3. Cable screen connection

The screen of the telecommunication cables connected directly to the device shall be terminated to the earthing connection point of the corresponding module.

Picture 3-5-1-3 An example of the cable screen connection

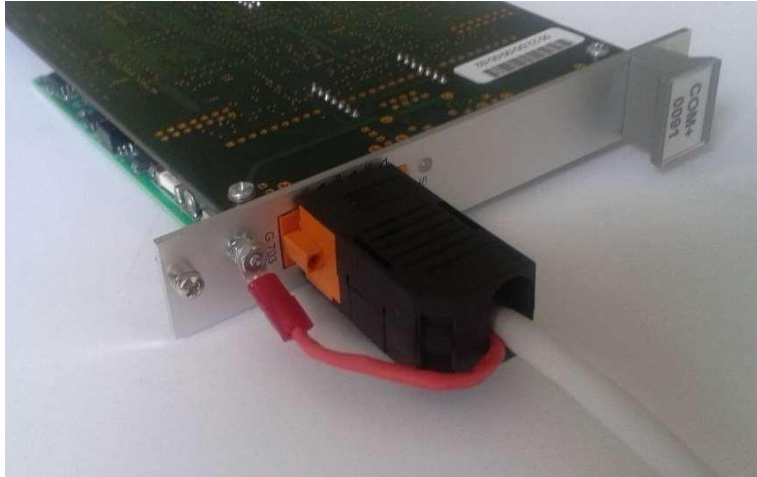

1.2.25.3.5.1.4. CT and VT circuits



The CT and VT circuits to be connected to the device shall be connected to the station earth system.

1.2.25.3.5.2. Connections of the device

Before connecting the wires, make sure that all voltage levels correspond to the device ratings. It is particularly important by the power supply, trip and binary input, CT and VT module

Use only the connectors provided to the device or identical ones.

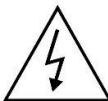

The CT connectors shall be fixed with screws provided. During the operation of the device, the CT connectors can be disconnected only after the CT circuits having short-circuited.

1.2.25.3.5.3. Optical ports



Take adequate measures to protect your eyes and do not view directly into optical ports.

The fiber optics cables are vulnerable. Sharp bending can damage them. The minimum bending radius can be between 15 cm and 25 cm approximately, depending on the type and the material of the cable. For details see the datasheets of the fiber optics cables to be installed. The fiber shall not be twisted or bent. When connecting or disconnecting the cable always hold the connector, not the cable.

1.2.25.3.5.4. Removing and changing modules

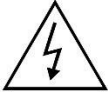

Before removing and changing modules first the power supply voltage of the device shall be disconnected. Then all the energizing quantities connected to each module of the device shall be disconnected. Before removing the connectors of the CT modules, the CT circuits shall be short-circuited and disconnected.

The protective earth connection can be disconnected last if it is necessary (e.g. when removing a Power supply module).



The devices contain components that are sensitive to electrostatic discharges. ESD wrist strap shall be worn during any operations with modules.



Some of the modules can operate at high internal temperatures. Remove these modules carefully to avoid any burn injury. Take care of the possible high temperature at each module.



The modules have got sharp edges. Remove them carefully to avoid injury.

After changing a module, it shall be fixed with the screws provided with a torque of 0,5 Nm. Use Philips 2 screwdriver.

1.2.25.4. Wiring

1.2.25.4.1. Tools for connecting

Screwdrivers for the connectors: blade 0,6/3,5 mm, 0,4/2,5 mm.

Cutter, stripper, crimper tools to prepare the connecting end of the wires.

1.2.25.4.2. Connectors

The “Connectors” section of the “EuroProt+ Hardware description” provides information about the required conductor dimensions and connecting methods. The “Connectors” table shall be used together with the other sections describing the different modules.

1.2.25.5. Deinstallation and Repair

1.2.25.5.1. Deinstallation



Before removing the device make sure, that all incoming power supply and control voltages are switched off. The earth connection of the device shall be disconnected last.

1.2.25.5.2. Repair



Thanks to its modular design, many hardware problems can be fixed by replacing single modules. By executing this procedure note, that the printed board’s surface may get hot during normal operation.



In addition, attention shall be paid to the sharp edges of the modules to avoid minor injuries on the hand.

1.2.25.5.3. Disposal



Removed IEDs shall be handed over to a local electronic waste handler for proper disposal and recycling.

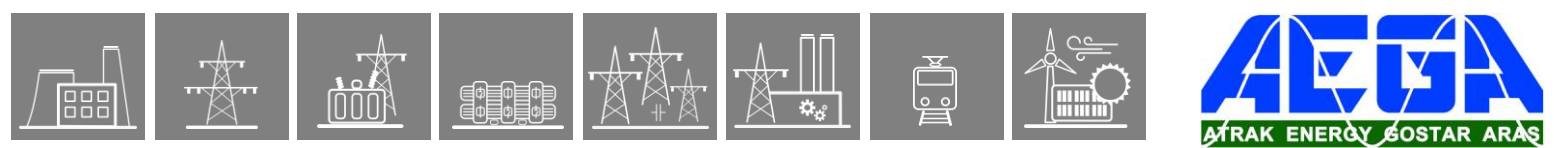
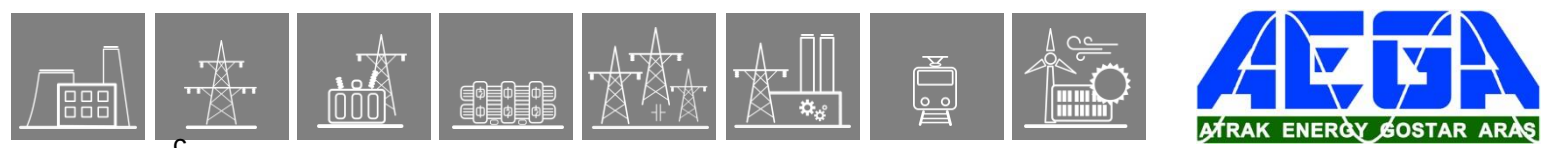

Table 5-3 Disposal of the components and parts

IED	PARTS	MATERIAL	METHOD OF DISPOSAL
Enclosure	Metal sheets, fastening elements	Aluminum, steel	Separation and recycling
Modules	Metallic parts, fastening elements	Aluminum, steel	Separation and recycling
	Mounted PC boards	Plastic, various electronic elements	Separation and recycling
	Connectors	Plastic, various metals	Separation and recycling
	Transformers, coils	Iron, copper, plastic, paper	Separation and recycling
	Relays	Iron, copper, plastic, other metals	Separation and recycling
Package	Box	Cardboard	Recycling
Attachments	Manuals, certificates	Paper	Recycling



C

2. Software configuration

2.1. Protection functions

2.1.1. Impedance protection with compounded circular characteristics

This impedance protection function can be applied as impedance protection with an offset circular characteristic or as a loss-of-field protection function for synchronous machines. Its main features are as follows:

- A full-scheme system provides continuous measurement of impedances separately in three independent phase-to-phase measuring loops as well as in three independent phase-to-earth measuring loops.
- Impedance calculation is conditional on the values of phase currents being sufficient.
- Full-scheme faulty phase identification is provided.
- The operate decision is based on offset circle characteristics. The impedance calculation is dynamically based on:
 - Measured loop voltages if they are sufficient for decision,
 - Voltages stored in the memory if they are available,
 - Optionally, the decision can be non-direction; in that case, the center of the circle is not shifted away from the origin.
- Binary input signals and conditions can influence the operation:
 - Blocking/enabling.
 - VT failure signal.

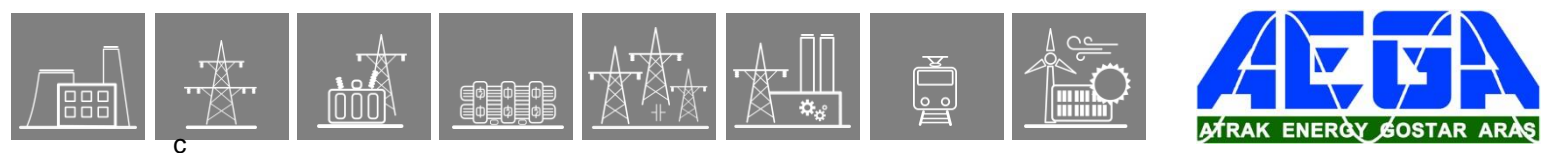

C

In case of a phase-to-earth fault, the phase voltage and the phase current modified by the zero sequence current have to be substituted:

$$u_{L1} = R_1(i_{L1} + \alpha_R 3i_o) + L_1 \frac{d}{dt}(i_{L1} + \alpha_L 3i_o)$$

Where

- R_1 is the positive sequence resistance of the line or cable section between the fault location and the relay location,
- L_1 is the positive sequence inductance of the line or cable section between the fault location and the relay location,
- $L1$ is the faulty phase,
- $3i_o = iL1+iL2+iL3$ is the Fourier fundamental component value of the zero sequence current of the protected line.

$$\alpha_R = \frac{R_o - R_1}{3R_1}$$

$$\alpha_L = \frac{L_o - L_1}{3L_1} = \frac{X_o - X_1}{3X_1}$$

The formula above shows that the factors for multiplying R and L values contain different “ α ” factors but they are real (not complex) numbers.

The applied numerical method is solving the differential equation of the faulty loop, based on the orthogonal components of the Fourier fundamental component vectors.

To achieve better filtering effect, the calculation is performed using the fundamental Fourier components of the voltages, currents and current derivatives. In Table 1-1, the voltages and currents are complex vectors. The calculation results complex impedances on the network frequency.

C

2.1.1.2.3. The principal scheme of the impedance calculation

Figure 1-3 shows the principal scheme of the impedance calculation Z_CALC.

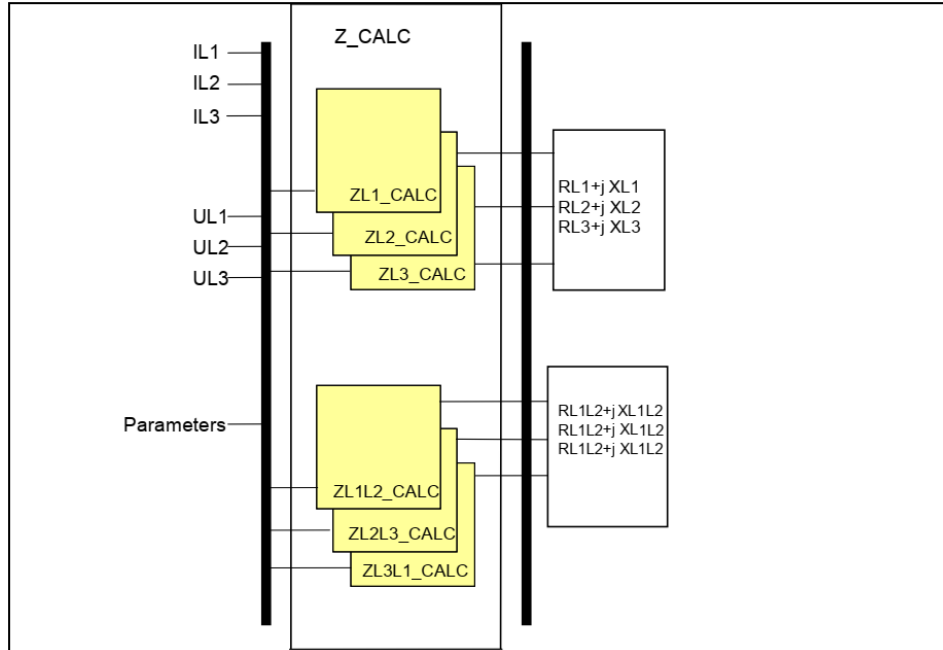

Figure 1-3 Principal scheme of the impedance calculation Z_CALC

The **inputs** are the Fourier components of:

- the three phase voltages,
- the three phase currents,
- parameters.

The **outputs** are the calculated positive sequence impedances (R+jX) of the six measuring loops:

- Impedances of the three phase-phase loops,
- Impedances of the three phase-ground loops.

The **measured values** of the Z_CALC module

Measured value	Dim.	Explanation
RL1+j XL1	ohm	Measured positive sequence impedance in the L1N loop
RL2+j XL2	ohm	Measured positive sequence impedance in the L2N loop
RL3+j XL3	ohm	Measured positive sequence impedance in the L3N loop
RL1L2+j XL1L2	ohm	Measured positive sequence impedance in the L1L2 loop
RL2L3+j XL2L3	ohm	Measured positive sequence impedance in the L2L3 loop
RL3L1+j XL3L1	ohm	Measured positive sequence impedance in the L3L1 loop

Table 1-2 The measured (calculated) values of the Z_CALC module

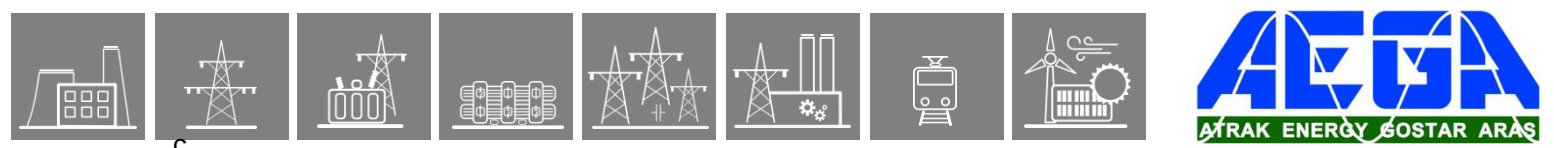

C

Float parameters

Parameter name	Title	Unit	Min	Max	Steps	Default
The zero sequence current compensation factor, calculated with X values						
IMP21_Alfal_FPar_	$(X_0 - X_1)/3X_1$		0	5	0.01	0
The zero sequence current compensation factor, calculated with R values						
IMP21_Alfar_FPar_	$(R_0 - R_1)/3R_1$		0	5	0.01	0

Table 1-3 The float parameters of the impedance calculation

Z_CALC includes six practically identical software modules for impedance calculation:

- The three routines of the phase group are activated by phase voltages, phase currents and the zero sequence current calculated from the phase current.
- The three routines for the phase-to-phase loops get line-to-line voltages calculated from the sampled phase voltages and they get differences of the phase currents. They do not need zero sequence currents for the calculation.

The calculated impedances are analogue outputs of the impedance protection function. They serve the purpose of checking possibility at commissioning.

C

2.1.1.2.4. Internal logic of the impedance calculation

Fig. 1-2 shows the internal logic of the impedance calculation.

The decision needs logic parameter settings and, additionally, internal logic signals. The explanation of these signals is as follows:

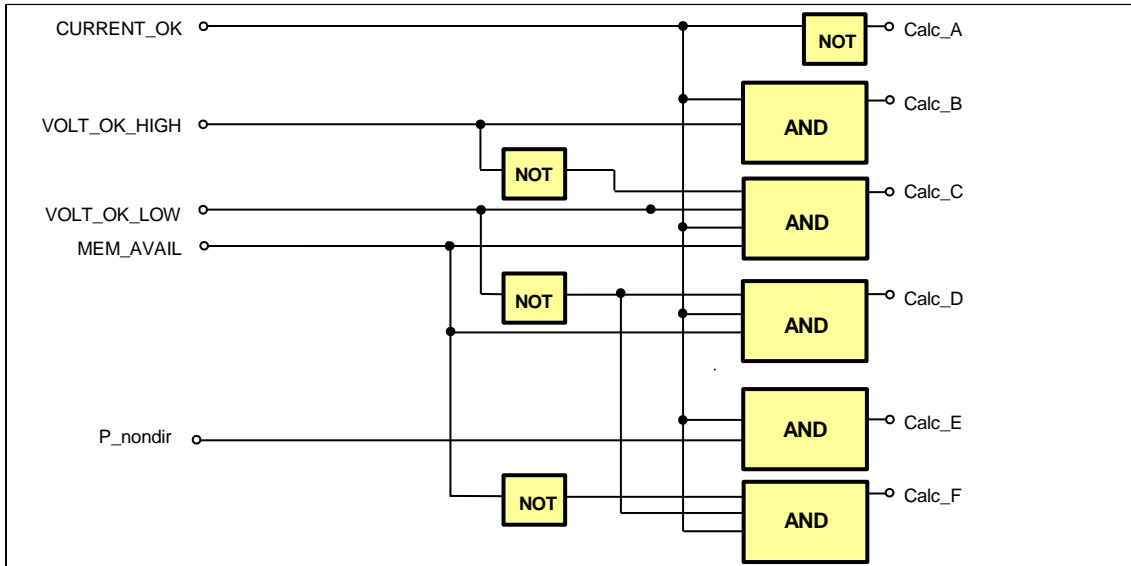

Figure 1-4 Internal logic of the impedance calculation Z_CALC

Parameter	Explanation
P_nondir	This logic variable is true if no directionality is programmed, i.e., the IMP21_Zn_EPar_(Operation) parameter is set to "NonDirectional".

Table 1-4 Enumerated parameters for the Z_CALC module

C

Input status signal	Explanation
CURRENT_OK	The current is suitable for impedance calculation in the processed loop if, after a zero crossing, there are three sampled values above a defined limit ($\sim 0.1I_n$). For a phase-ground loop calculation, it is also required that the sum of the phase currents ($3I_o$) should be above $I_{phase}/4$. This status signal is generated within the <u>Z_CALC</u> module based on the parameter <u>IMP21_Imin_IPar_</u> (I minimum) and in case of phase-ground loops on parameters <u>IMP21_loBase_IPar_</u> (lo Base sens.) and <u>IMP21_loBias_IPar_</u> (lo Bias)
VOLT_OK_HIGH	The voltage is suitable for the calculation if the most recent ten sampled values include a sample above the defined limit (35% of the nominal loop voltage). This status signal is generated within the <u>Z_CALC</u> module.
VOLT_OK_LOW	The voltage can be applied for the calculation of the impedance if the three most recent sampled three values include a sample above the defined lower limit (5% of the nominal loop voltage), but in this case the direction is to be decided using the voltage samples stored in the memory because the secondary swings of the capacitive voltage divider distort the sampled voltage values. Below this level, the direction is decided based on the sign either of the real part of the impedance or that of the imaginary part of the impedance, whichever is higher. This status signal is generated within the <u>Z_CALC</u> module.
MEM_AVAIL	This status signal is true if the voltage memory is filled up with available samples above the defined limit for 80 ms. This status signal is generated within the <u>Z_CALC</u> module.

Table 1-5 Binary signals for the Z_CALC module

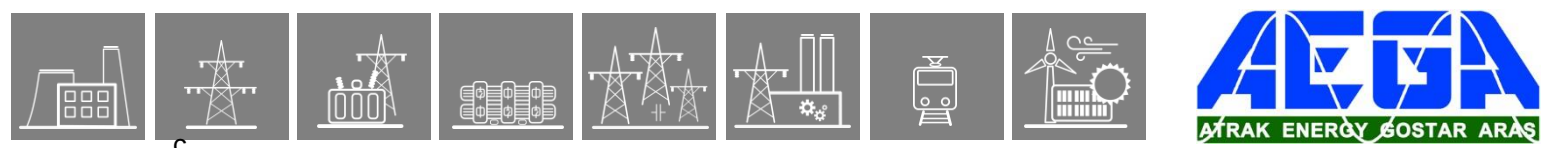

C

The outputs of the scheme are calculation methods applied for impedance calculation for the individual zones.

Calculation method	Explanation
Calc(A)	No current is available, the impedances are supposed to be higher than the possible maximal setting values $R=1000000$ mohm, $X=1000000$ mohm
Calc(B)	The currents and voltages are suitable for the correct impedance calculation and directional decision $R, X=f(u, i)$
Calc(C)	The currents are suitable but the voltages are in the range of the CVT swings, so during the first 35 ms the directional decision is based on pre-fault voltages stored in the memory $R, X=f(u, i)$ direction = $f(U_{mem}, i)$ /in the first 35 ms/ $R, X=f(u, i)$ direction = $f(u, i)$ /after 35 ms/
Calc(D)	The currents are suitable but the voltages are too low. The directional decision is based on pre-fault voltages stored in the memory $R, X=f(u, i)$ direction = $f(\max\{R(U_{mem}, i), X(U_{mem}, i)\})$
Calc(E)	If no directional decision is required, the decision is based on the absolute value of the impedance $R=abs(R), X=abs(X)$
Calc(F)	If the decision is not possible (no voltage, no pre-fault voltage), the impedance is set to a value above the possible impedance setting $R=1000500$ mohm, $X=1000500$ mohm

Table 1-6 Calculation methods applied in the Z_CALC module

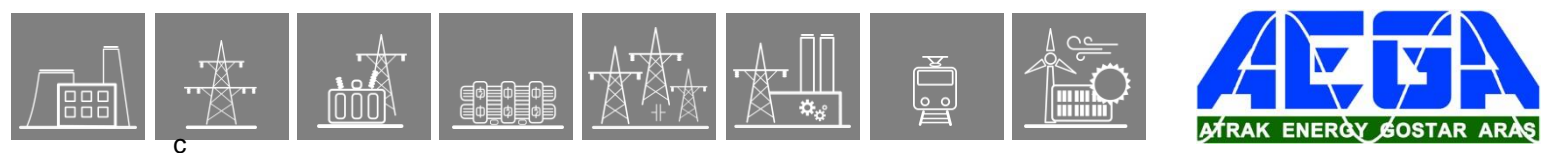

C

2.1.1.2.5. The impedance calculation methods

The short explanation of the internal logic for the impedance calculation is as follows:

Calculation method Calc(A):

If the CURRENT_OK status signal is false, the current is very small, therefore no fault is possible. In this case, the impedance is set to extreme high values and no further calculation is performed:

$$R=1000000, X=1000000.$$

The subsequent decisions are performed if the current is sufficient for the calculation.

Calculation method Calc(B):

If the CURRENT_OK status signal is true and the VOLT_OK_HIGH status signal is true as well, then the current is suitable for calculation and the voltage is sufficient for the directionality decision. In this case, normal impedance calculation is performed based on the sampled currents and voltages. (The calculation method - the function "f" - is explained later.)

$$R, X=f(u, i)$$

Calculation method Calc(C):

If the CURRENT_OK status signal is true but the VOLT_OK_HIGH status signal is false or there are voltage swings, the directionality decision cannot be performed based on the available voltage signals temporarily. In this case, if the voltage is above a minimal level (in the range of possible capacitive voltage transformer swings), then the VOLT_OK_LOW status is "true", the magnitude of R and X is calculated based on the actual currents and voltages but the direction of the fault (the +/- sign of R and X) must be decided based on the voltage value stored in the memory 80 ms earlier. (The high voltage level setting assures that during the secondary swings of the voltage transformers, no IMPtorted signals are applied for the decision). This procedure is possible only if there are stored values in the memory for 80 ms and these values were sampled during a healthy period.

$$R, X=f(u, i) \quad \text{direction} = f(U_{mem}, i) \text{ /in the first 35 ms/}$$

After 35 ms (when the secondary swings of the voltage transformers decayed), the directional decision returns to the measured voltage signal again:

$$R, X=f(u, i) \quad \text{direction} = f(u, i) \text{ /after 35 ms/}$$

Calculation method Calc(D):

If the voltage is below the minimal level, then the VOLT_OK_LOW status is "false" but if there are voltage samples stored in the memory for 80 ms, then the direction is decided based on the sign either of the real part of the impedance or that of the imaginary part of the impedance, whichever is higher.

$$R, X=f(u, i) \quad \text{direction} = f(\max\{R(U_{mem}, i), X(U_{mem}, i)\})$$

C

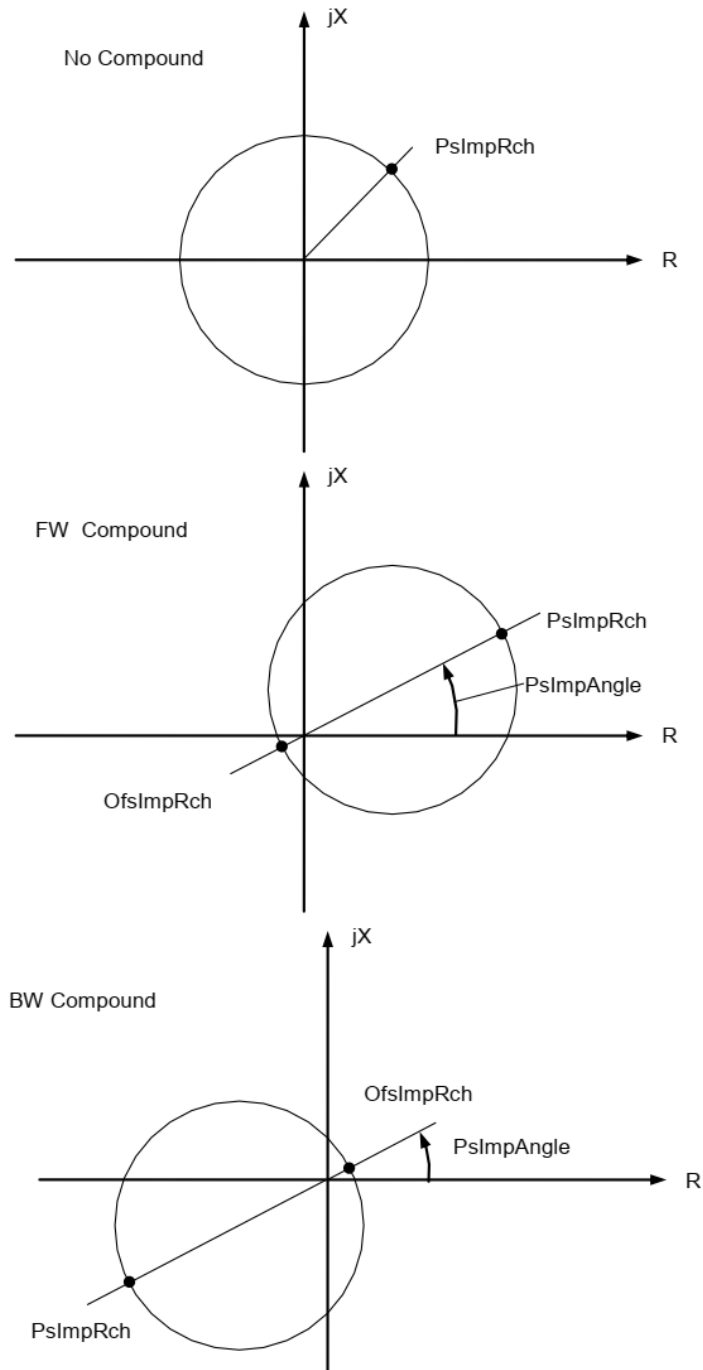

Figure 1-5 The offset circle characteristic

If a measured impedance point is inside the circle, the algorithm generates the true value of the related output binary signal.

The calculated impedance values are compared one by one with the setting values of the „offset circle” characteristics. This procedure is shown schematically on Figure 1-6.

C

Output values

Input values	Explanation
ZL1	The impedance in the fault loop L1N is inside the characteristics
ZL2	The impedance in the fault loop L2N is inside the characteristics
ZL3	The impedance in the fault loop L3N is inside the characteristics
ZL1L2	The impedance in the fault loop L1L2 is inside the characteristics
ZL2L3	The impedance in the fault loop L2L3 is inside the characteristics
ZL3L1	The impedance in the fault loop L3L1 is inside the characteristics

Table 1-8 The output status signals of the OFFSET CIRCLE module

The parameters needed in the characteristic evaluation procedure of the impedance protection function are explained in the following tables.

Enumerated parameters

Parameter name	Title	Selection range	Default
Selection of the operating mode			
IMP21_Op_EPar_	Operation	Off, NoCompound, FWCompound, BWCompound	NoCompound

Table 1-9 The enumerated parameters of the offset circle module

Integer parameters

Parameter name	Title	Unit	Min	Max	Step	Default
Positive impedance angle						
IMP21_Angle_IPar_	PslmpAng	deg	0	90	1	90

Table 1-10 Integer parameters of the circular impedance protection function

Float parameters

Parameter name	Title	Unit	Min	Max	Digits	Default
Offset impedance reach (see Figure 1-5)						
IMP21_Z1_FPar_	OfsImpRch	ohm	-150	150	-2	0.0
Positive impedance reach (see Figure 1-5)						
IMP21_Z2_FPar_	PslmpRch,	ohm	0.1	250	-2	10

Table 1-11 The float parameters of the offset circle module

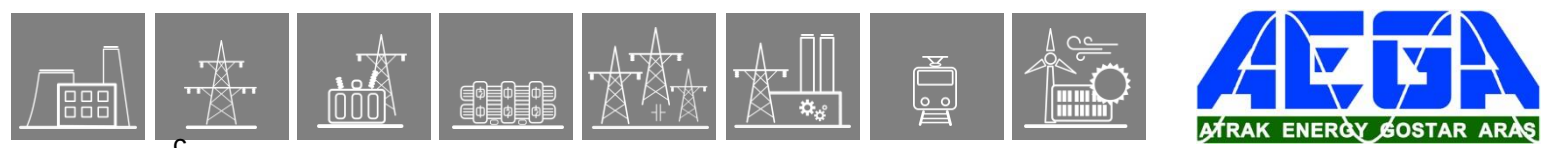

C

Binary output status signals

Binary status signal	Title	Explanation
IMP21_StL1_GrI_	Start L1	The impedance of phase L1 is within the characteristics
IMP21_StL2_GrI_	Start L2	The impedance of phase L2 is within the characteristic
IMP21_StL3_GrI_	Start L1	The impedance of phase L3 is within the characteristics
IMP21_GenSt_GrI_	General Start	General start signal of the function
IMP21_GenTr_GrI_	General Trip	General trip signal of the function

Table 1-13 Binary output signals of the phase selection logic

Boolean parameters

Parameter name	Title	Default	Explanation
IMP21_StOnly_BPar_	Impedance Start Only	0	Set 0 value to also generate an operate signal

Table 1-14 The Boolean parameters of the phase selection logic

Timer parameters

Parameter name	Title	Unit	Min	Max	Step	Default
Time delay						
IMP21_DeI_TPar_	Time delay	msec	0	60000	1	500

Table 1-15 Timer parameters of the phase selection logic

C

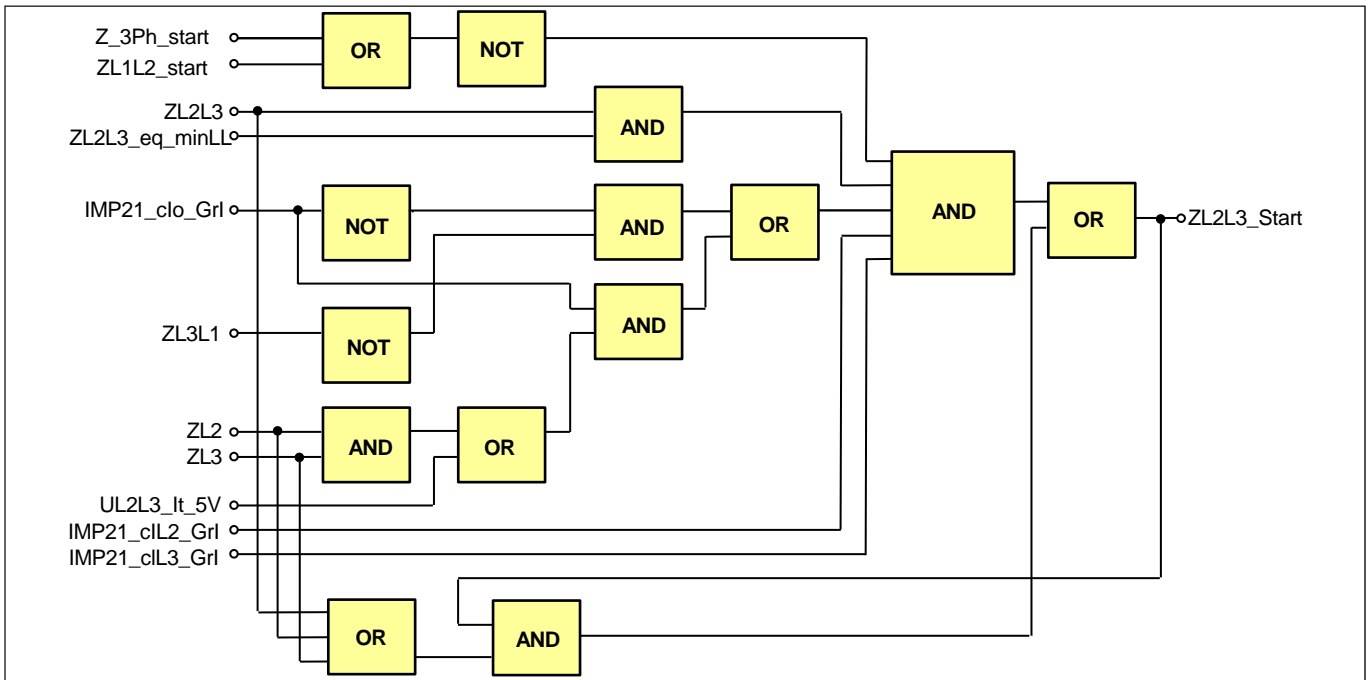

Figure 1-9 L2L3 fault detection

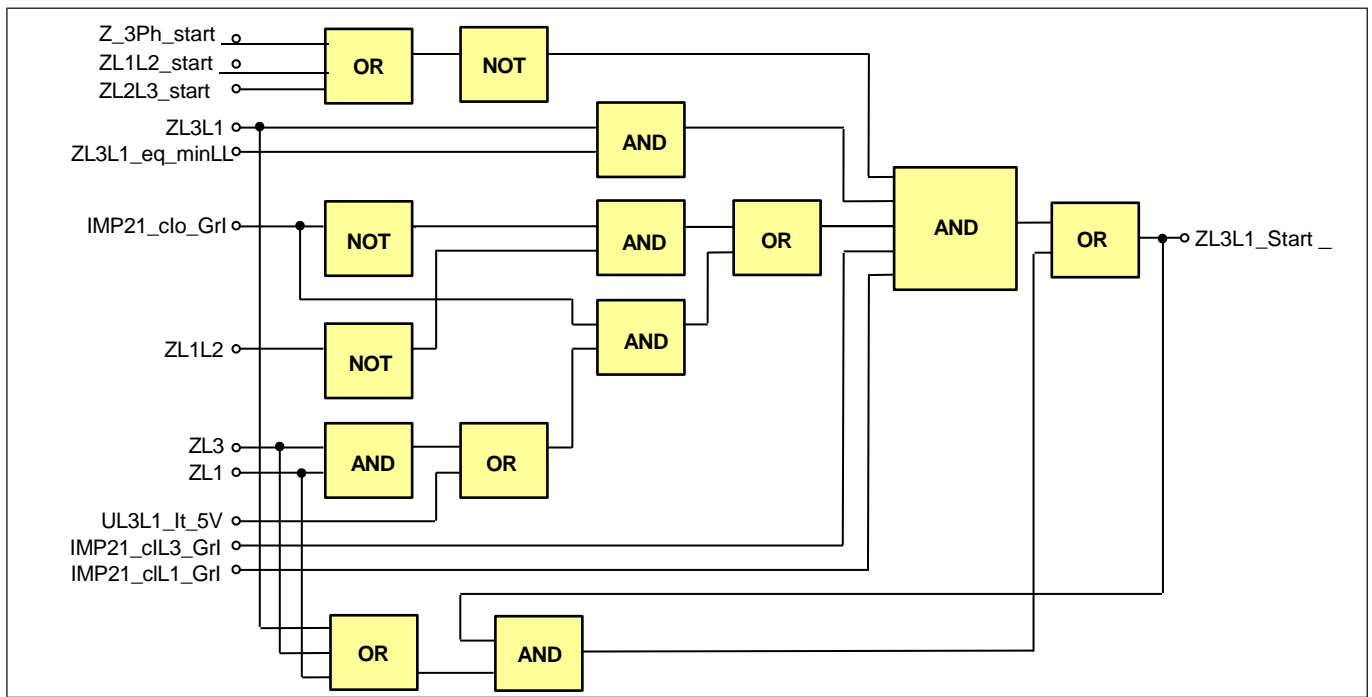

Figure 1-10 L3L1 fault detection in Zone “n” (n=1...5)

Output status signals	Explanation
L1L2_Start	L1L2 loop start of the impedance protection function
L2L3_Start	L2L3 loop start of the impedance protection function
L3L1_Start	L3L1 loop start of the impedance protection function

Table 1-18 Phase-to-phase loop start of the impedance protection function

C

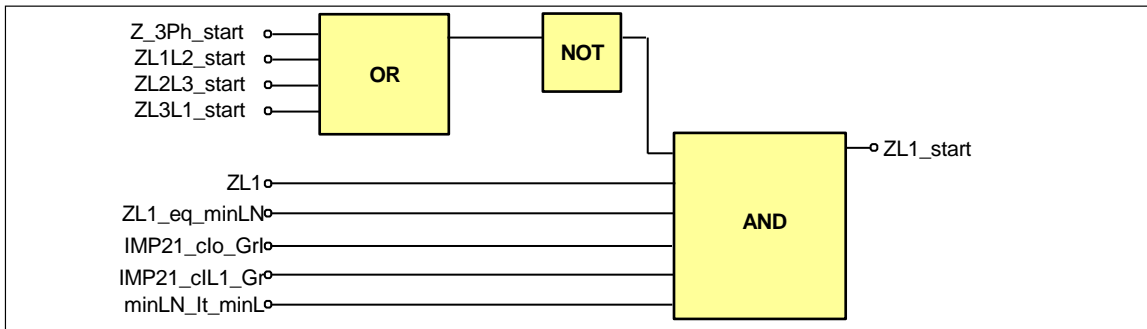

Figure 1-11 L1N fault detection

Figure 1-12 and Figure 1-13 show a similar logic for the loops “L2” and “L3”, respectively.

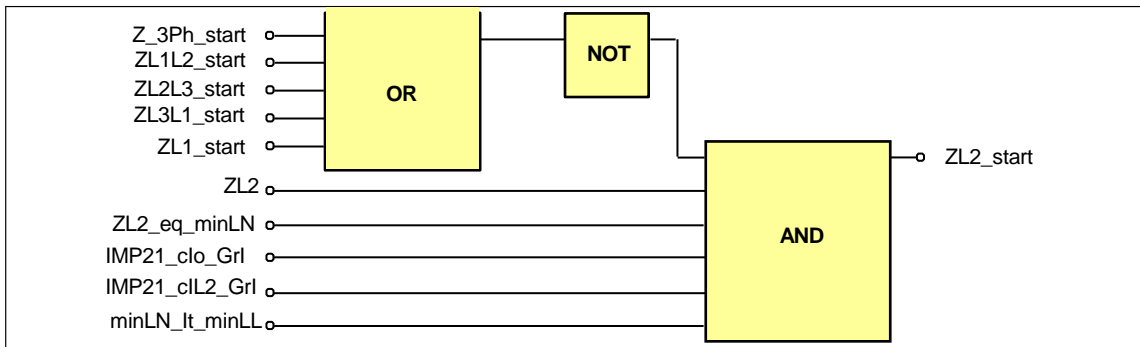

Figure 1-12 L2N fault detection

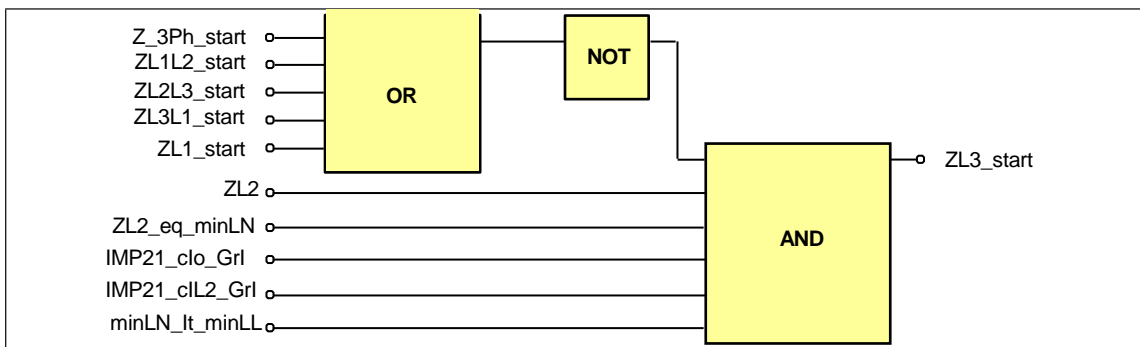

Figure 1-13 L3N fault detection

Output status signals	Explanation
ZL1_Start	L1N loop start of the impedance protection function
ZL2_Start	L2N loop start of the impedance protection function
ZL3_Start	L3N loop start of the impedance protection function

Table 1-20 Phase-to-neutral loop start of the impedance protection function

C

Input status signals	Explanation
ZL1L2_Start	Outputs of the previous decisions
ZL2L3_Start	Outputs of the previous decisions
ZL3L1_Start	Outputs of the previous decisions
ZL1_Start	Outputs of the previous decisions
ZL2_Start	Outputs of the previous decisions
ZL1_equ_minLN	The calculated impedance of fault loop L1 is the smallest one
ZL2_equ_minLN	The calculated impedance of fault loop L2 is the smallest one
ZL3_equ_minLN	The calculated impedance of fault loop L3 is the smallest one
ZL1	The calculated impedance of the fault loop L1N is within the characteristic
ZL2	The calculated impedance of the fault loop L2N is within the characteristic
ZL3	The calculated impedance of the fault loop L3N is within the characteristic
IMP21_cIL1_Grl	The current in phase L1 is sufficient for impedance calculation
IMP21_cIL2_Grl	The current in phase L1 is sufficient for impedance calculation
IMP21_cIL3_Grl	The current in phase L1 is sufficient for impedance calculation
IMP21_cIo_Grl	The zero sequence current component is sufficient for impedance calculation in LN loops

Table 1-21 Inputs needed to decide LN loop start of the impedance protection function

C

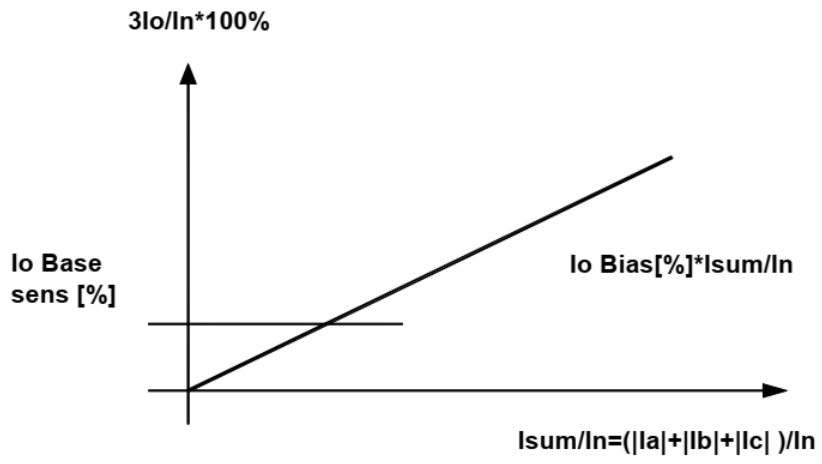

Figure 1-15 Percentage characteristic for earth-fault detection

C

2.1.1.6. Technical summary

2.1.1.6.1. Technical data

Function	Range	Accuracy
Rated current I_n	1/5A, parameter setting	
Rated Voltage U_n	100/200V, parameter setting	
Current operate range	20 – 2000% of I_n	
Voltage operate range	3-110 % of U_n	
Impedance effective range $I_n=1A$ $I_n=5A$	0.1 – 200 Ohm 0.1 – 40 Ohm	±5%
Zone static accuracy	48 Hz – 52 Hz	±7%
	49.5 Hz – 50.5 Hz	±2%
Zone angular accuracy		±3 °
Operate time	Typically 55 ms	±3 ms
Minimum operate time	<60 ms @ f nominal < 100 ms @ 48-52 Hz	
Reset time	30 – 55 ms	
Reset ratio	1.1	

Table 1-25 The technical parameters of the impedance protection function

2.1.1.6.2. The on-line measured values of the impedance protection function

Name	Title	Explanation
IMP21_L1N_R_OLM_	L1N loop R	Measured positive sequence resistance in L1N loop
IMP21_L1N_X_OLM_	L1N loop X	Measured positive sequence reactance in L1N loop
IMP21_L2N_R_OLM_	L2N loop R	Measured positive sequence resistance in L2N loop
IMP21_L2N_X_OLM_	L2N loop X	Measured positive sequence reactance in L2N loop
IMP21_L3N_R_OLM_	L3N loop R	Measured positive sequence resistance in L3N loop
IMP21_L3N_X_OLM_	L3N loop X	Measured positive sequence reactance in L3N loop
IMP21_L12_R_OLM_	L12 loop R	Measured positive sequence resistance in L12 loop
IMP21_L12_X_OLM_	L12 loop X	Measured positive sequence reactance in L12 loop
IMP21_L23_R_OLM_	L23 loop R	Measured positive sequence resistance in L23 loop
IMP21_L23_X_OLM_	L23 loop X	Measured positive sequence reactance in L23 loop
IMP21_L31_R_OLM_	L31 loop R	Measured positive sequence resistance in L31 loop
IMP21_L31_X_OLM_	L31 loop X	Measured positive sequence reactance in L31 loop

Table 1-26 The measured values of the impedance protection function

2.1.1.6.4. Summary of the generated output signals

The **binary output status signals** of the circular impedance protection function are listed in Table 1-32.

Binary status signal	Title	Explanation
IMP21_StL1_GrI_	Start L1	The impedance of phase L1 is within the characteristic
IMP21_StL2_GrI_	Start L2	The impedance of phase L2 is within the characteristic
IMP21_StL3_GrI_	Start L1	The impedance of phase L3 is within the characteristic
IMP21_GenSt_GrI_	General Start	General start signal of the function
IMP21_GenTr_GrI_	General Trip	General trip signal of the function

Table 1-32 The binary output status signals of the impedance protection function

2.1.1.6.5. Summary of the input signals

Binary status signals

The circular impedance protection function has binary input status signals. **The conditions are defined by the user, applying the graphic equation editor.**

The **binary input status signals** of the circular phase-to-neutral impedance protection function are listed in Table 1-33.

Binary status signal	Title	Explanation
IMP21_Blk_GrO_	Block	Blocking of the impedance protection function
IMP21_VTSBlk_GrO_	Block from VTS	Blocking of the impedance protection function from the VT supervision

Table 1-33 The binary input signals of the impedance protection function

2.1.1.6.6. The function block

The function block of the impedance protection function is shown in Figure 1-16. This block shows all binary input and output status signals that are applicable in the graphic equation editor.

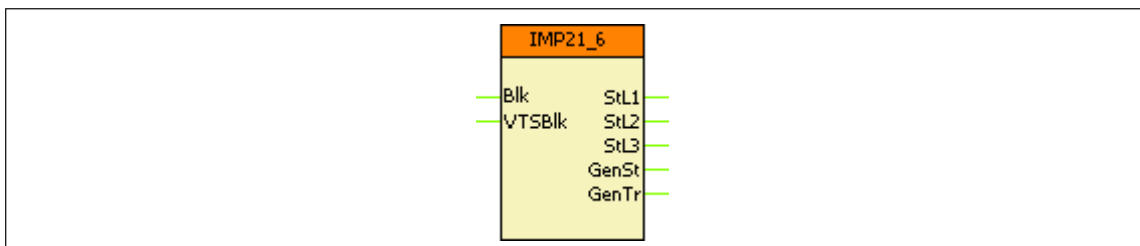
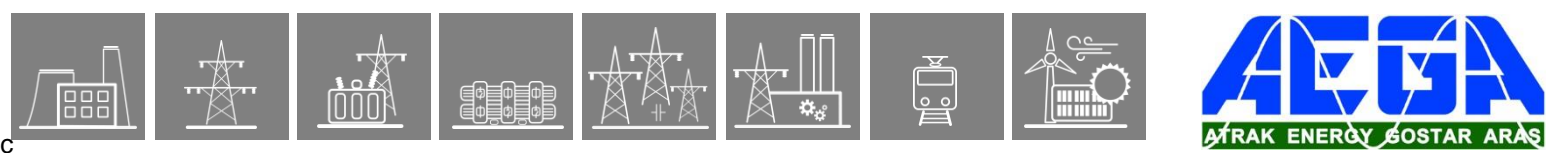

Figure 1-16 The function block of the impedance protection function

The names of the input and output signals are parts of the “Binary status signal” names listed in Table 1-32 and Table 1-33 above.



2.1.2. Overexcitation protection function

2.1.2.1. Application

The overexcitation protection function is applied to protect generators and unit transformers against high flux values causing saturation of the iron cores and consequently high magnetizing currents.

The problem to be solved is as follows. The flux is the integrated value of the voltage:

$$\Phi(t) = \Phi_0 + \int_0^t u(t) dt$$

In steady state, this integral can be high if the area under the sinusoidal voltage-time function is large. Mathematically this means that in steady state the flux, as the integral of the sinusoidal voltage function, can be expressed as

$$\Phi(t) = k \frac{U}{f} \cos \omega t$$

The peak value of the flux increases if the magnitude of the voltage increases, and/or the flux can be high if the duration of a period increases; this means that the frequency of the voltage decreases. That is, the flux is proportional to the peak value (or to the RMS value) of the voltage and inversely proportional to the frequency.

Note: the overexcitation protection function is intended to be applied near the generator, where the voltage is expected to be pure sinusoidal, without any distortion. Therefore, a continuous integration of the voltage and a simple peak detection algorithm can be applied.

The effect of high flux values is the symmetrical saturation of the iron core of the generator or that of the unit transformer. During saturation, the magnetizing current is high and distorted; high current peaks can be detected. The odd harmonic components of the current are of high magnitude and the RMS value of the current also increases. The high peak values of the currents generate high dynamic forces, the high RMS value causes overheating. During saturation, the flux leaves the iron core and high eddy currents are generated in the metallic part of the generator or transformer in which normally no current flows, and which is not designed to withstand overheating.

The frequency can deviate from the rated network frequency during start-up of the generator or at an unwanted disconnection of the load. In this case the generator is not connected to the network and the frequency is not kept at a "constant" value. If the generator is excited in this state and the frequency is below the rated value, then the flux may increase above the tolerated value. Similar problems may occur in distributed generating stations in case of island operation.

The overexcitation protection is designed to prevent this long-term overexcited state.

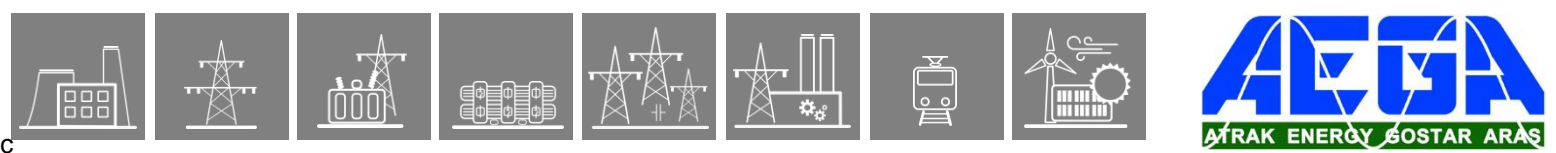

2.1.2.2. Mode of operation

2.1.2.2.1. Calculation of the flux

The flux is calculated continuously as the integral of the voltage. In case of the supposed sinusoidal voltage, the shape of the integrated flux will be sinusoidal too, the frequency of which is identical with that of the voltage. The magnitude of the flux can be found by searching for the maximum and the minimum values of the sinusoid.

2.1.2.2.2. Starting of the function

The magnitude can be calculated if at least one positive and one negative peak value have been found, and the function starts if the calculated flux magnitude is above the setting value. Accordingly, the starting delay of the function depends on the frequency: if the frequency is low, more time is needed to reach the opposite peak value. In case of energizing, the time to find the first peak depends on the starting phase angle of the sinusoidal flux. If the voltage is increased continuously by increasing the excitation of the generator, this time delay cannot be measured.

2.1.2.2.3. Operating characteristics

The most harmful effect of the overexcited state is unwanted overheating. As the heating effect of the distorted current is not directly proportional to the flux value, inverse type characteristics can be applied. The IEEE type characteristic can be selected for general applications or the user can specify a custom characteristic to fulfill any special needs. If the overexcitation increases, the operating time decreases. To meet simpler requirements, a definite-time characteristic is also offered as an alternative.

The supervised quantity is the calculated U/f value as a percentage of the nominal values (index N):

$$G = \frac{\frac{U}{f}}{\frac{U_N}{f_N}} 100[\%] = \frac{\frac{U}{U_N}}{\frac{f}{f_N}} 100[\%]$$

The over-dimensioning of generators in this respect is usually about 5%, that of the transformer about 10%, but for unit transformers this factor can be even higher.

By function pickup, the protection generates a start signal and a delayed alarm signal aimed to inform the controller to decrease the excitation. If the time delay (determined by the parameter values of the selected characteristics) expires, the function generates a trip command to decrease or to switch off the excitation and the generator.

2.1.2.2.3.1. Definite time characteristic

Operating time

$$t(G) = t_{OP} \text{ when } G > G_S$$

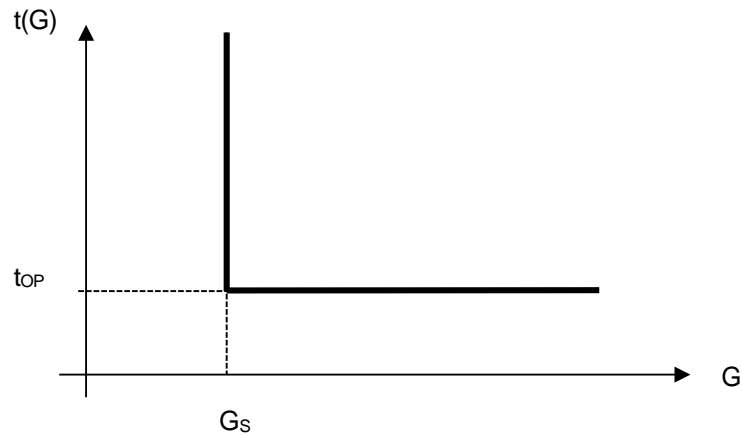

Figure 1-1 Overexcitation independent time characteristic

t_{OP} (seconds)	theoretical operating time if $G > G_S$, fix, according to the parameter setting "Definite Time Delay".
G	measured value of the characteristic quantity; this is the $\frac{U}{f}$ peak value as a percentage of the rated $\frac{U_N}{f_N}$ value.
G_S	setting value of the characteristic quantity ("Start U/f HighSet"). This is the $\frac{U_{set}}{f_{set}}$ peak value as a percentage of the rated $\frac{U_N}{f_N}$ value.

Reset time

$$t(G) = t_{Drop-off} \text{ when } G < 0.95 * G_S$$

where

$t_{Drop-off}$ (seconds) drop-off time if $G < 0.95 * G_S$, fix value.

2.1.2.2.3.2. Custom made inverse time characteristic

The custom characteristic can be defined by 7 points, where the user can select the desired U/f values and their corresponding time delays. Trip time between the points is determined by linear interpolation. The first U/f point of the characteristic will initiate the function start. Definite time characteristic settings in the previous section will be also effective on the custom-made trip curve.

Thermal counter

Once the actual U/f value initiates a function start, a thermal counter also starts. At counter value 100%, the function initiates a trip command.

Reset time

If the calculated flux is below the drop-off flux value (when $G < 0.95 * G_s$), then the calculated flux value decreases linearly to zero. The time to reach zero is defined by the parameter "Cooling Time".

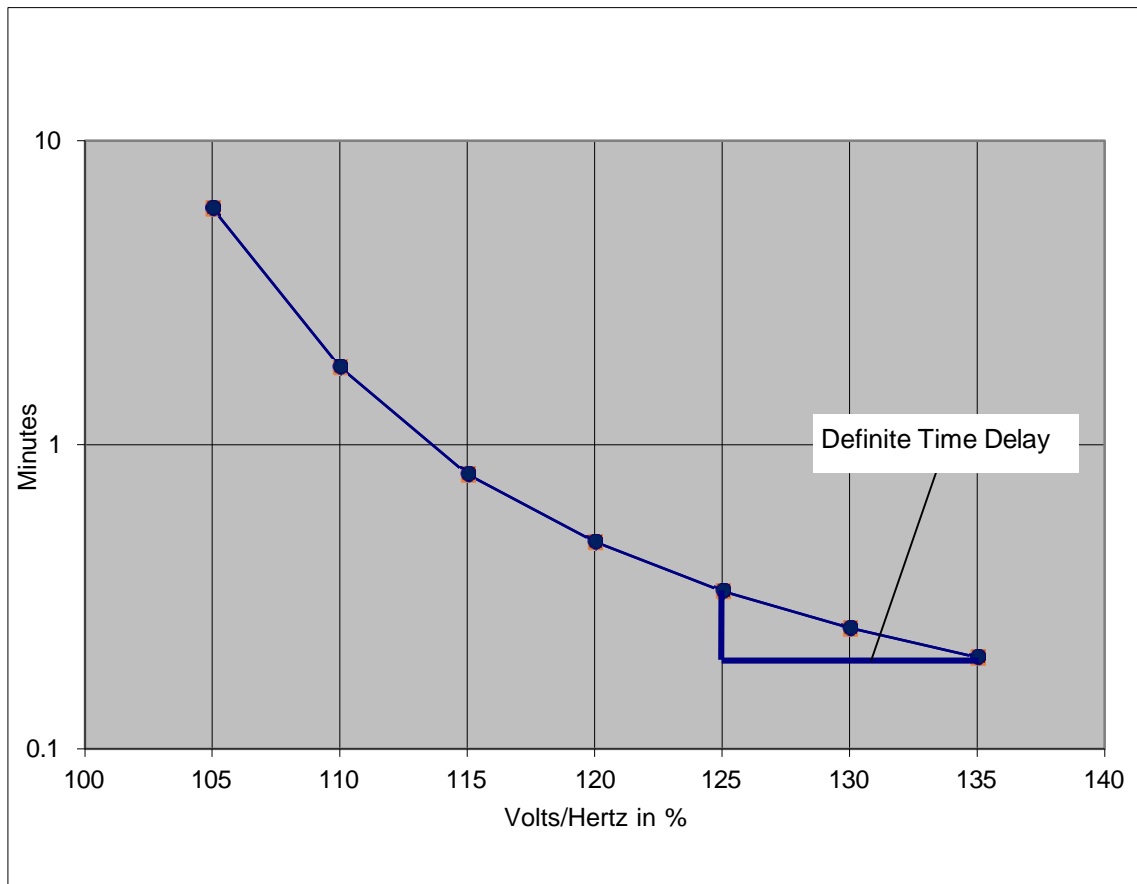

Figure 1-2 Custom inverse time characteristics

2.1.2.2.3.3. IEEE standard inverse time characteristic

Operating time in seconds

- “IEEE square law” acc. to IEEE Std C37.102

$$t = \frac{0.18 * TMS}{\left(\frac{U/f}{U_N/f_N} - \frac{U_{set}/f_{set}}{U_N/f_N}\right)^2} = \frac{0.18 * TMS}{(G - G_S)^2}$$

where

TMS = 1... 60,	time multiplier setting,
U/f	flux value calculated at the measured voltage and frequency,
U _N /f _N	flux at rated voltage and rated frequency,
U _{set} /f _{set}	flux setting value.

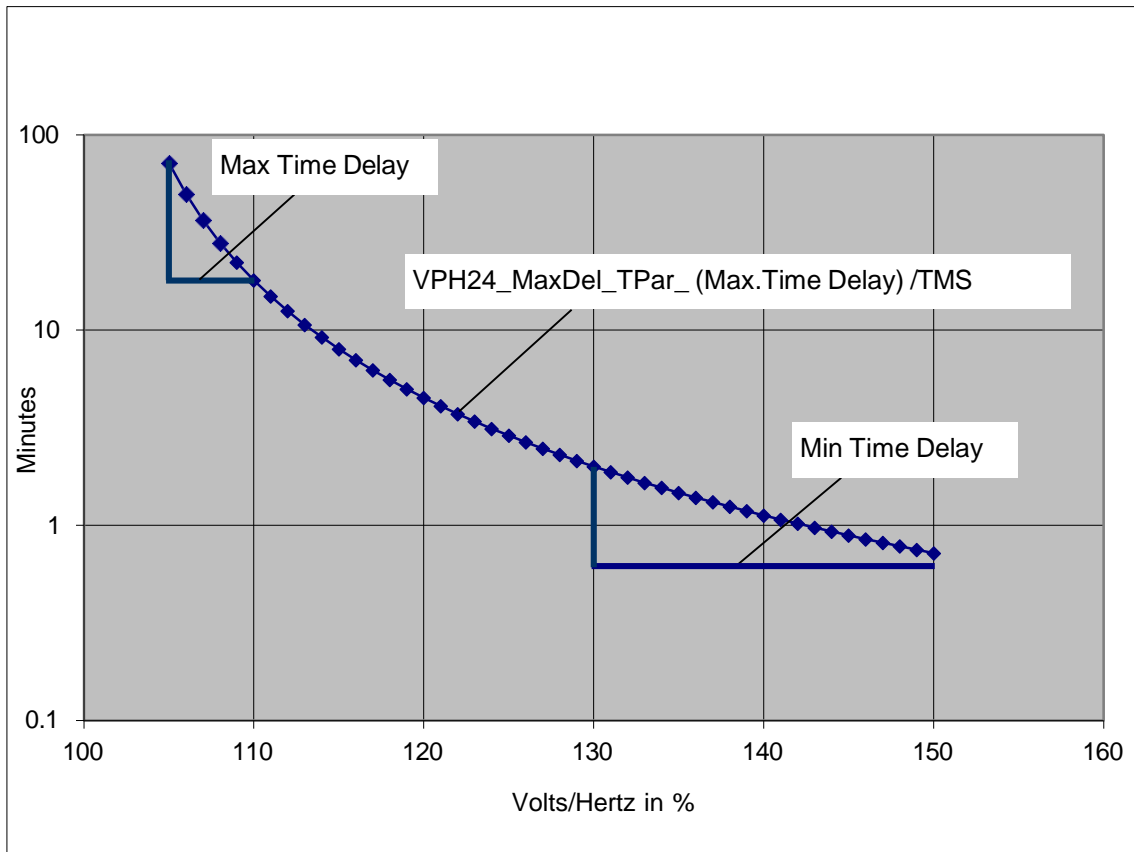
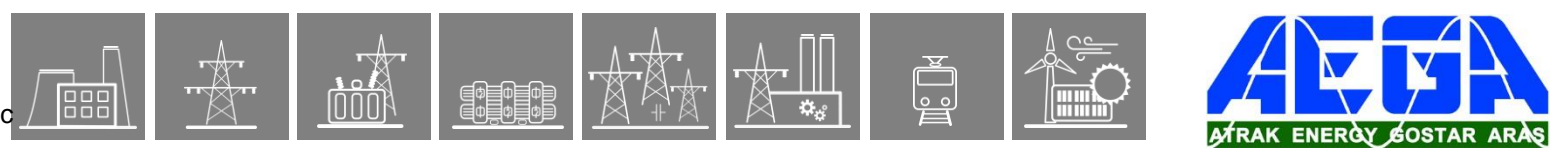

Figure 1-3 IEEE standard inverse time characteristics

If the function starts, the maximum tripping time is limited by the parameter “Max Time Delay”. This time delay is valid if the flux is above the preset value of “Start U/f LowSet”.

This inverse type characteristic is also combined with a minimum time delay, the value of which is set by user parameter “Min Time Delay”. This time delay is valid if the flux is above the setting value of “Start U/f HighSet”.



Reset time

If the calculated flux is below the drop-off flux value (when $G < 0.95 * G_s$), then the calculated flux value decreases linearly to zero. The time to reach zero is defined by the parameter “*Cooling Time*”.

2.1.2.2.4. Analogue input of the function



Overexcitation is a typically symmetrical phenomenon. There are other dedicated protection functions against asymmetry. Accordingly, the processing of a single voltage is sufficient. In a network with isolated neutral, the phase voltage is not exactly defined due to the uncertain zero sequence voltage component. Therefore, line-to-line voltages are calculated based on the measured phase voltages, and one of them is assigned to overfluxing protection.

As overexcitation is a phenomenon which is typical if the generator or the generator transformer unit is not connected to the network, the voltage drop does not need any compensation. If the voltage is measured at the supply side of the unit transformer, then the voltage is higher than the voltage of the magnetization branch of the transformer's equivalent circuit. Thus, the calculated flux cannot be less than the real flux value. The protection operates with increased security.

2.1.2.3. Structure of the overexcitation protection algorithm

Fig.1-4 shows the structure of the overexcitation protection (VPH24) algorithm.

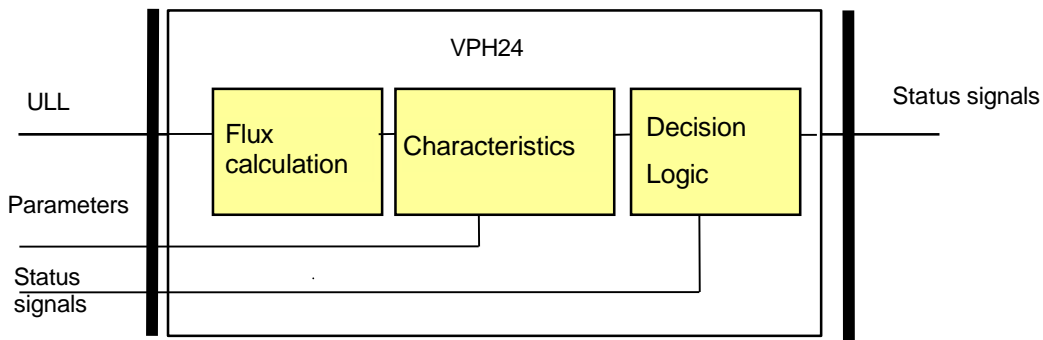

Figure 1-4 Structure of the overexcitation protection algorithm

The **inputs** are

- the sampled values of a line-to-line voltage (ULL),
- parameters,
- status signals.

The **outputs** are

- the binary output status signals.

The **software modules** of the overexcitation protection function:

Flux calculation

This module integrates the voltage to obtain the flux time-function and determines the magnitude of the flux.

Characteristics

This module calculates the required time delay based on the magnitude of the flux and the parameter settings.

Decision logic

The decision logic module combines the status signals to generate the trip command of the function.

The following description explains the details of the individual components.

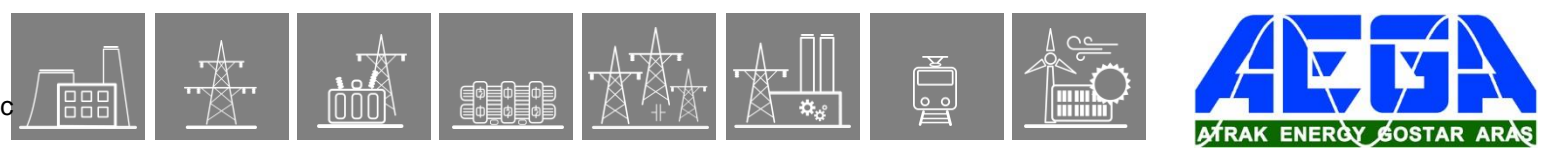

2.1.2.4. The flux calculation

This module integrates the voltage to obtain the flux time-function and determines the magnitude of the flux.

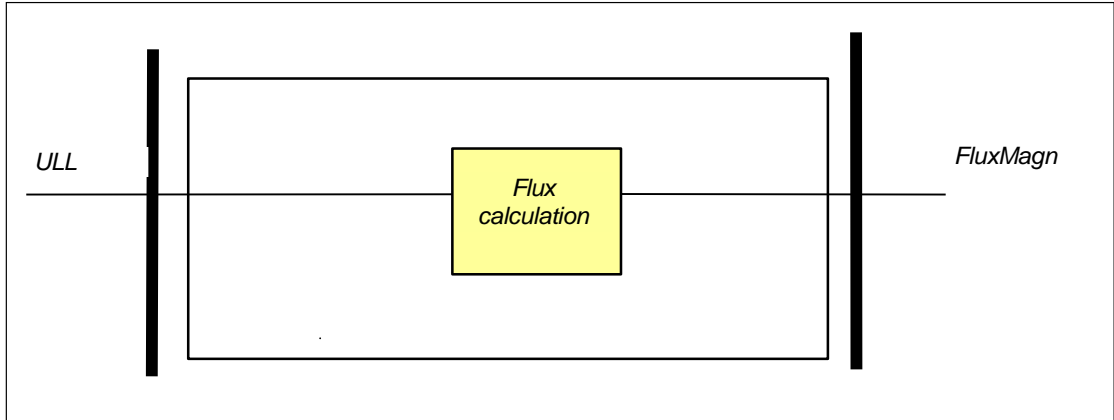
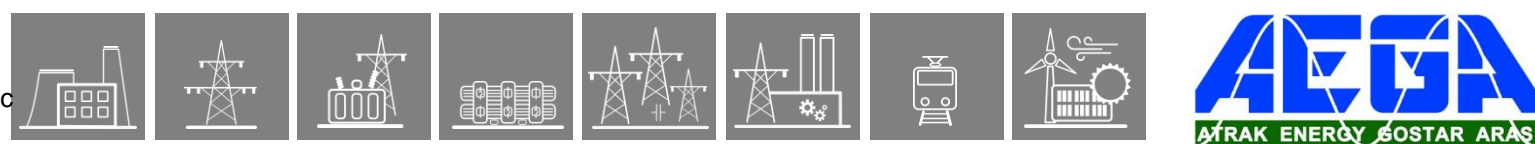

Figure 1-5 Principal scheme of the flux calculation

The **inputs** are the sampled values of a line-to-line voltage (ULL).

The **output** is the magnitude of the flux (FluxMagn), internal signal.



2.1.2.5. The definite time and the inverse type characteristics

This module calculates the required time delay based on the magnitude of the flux and the parameter settings.

The **inputs** are the magnitude of the flux (FluxMagn) and parameters.

The **outputs** are the internal status signals of the function. These indicate the started state and the generated trip command if the time delay determined by the characteristics expired.

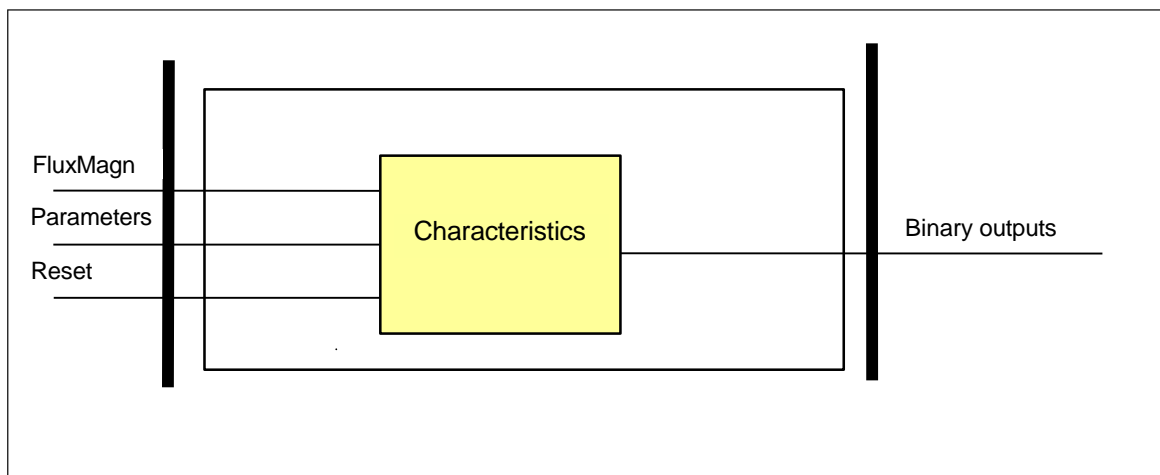

Figure 1-6 Schema of the characteristic calculation

Enumerated parameter

Table 1-1 The enumerated parameter of the overexcitation protection function

PARAMETER NAME	TITLE	SELECTION RANGE	DEFAULT
Parameter for type selection			
VPH24_Operation_EPar_	Operation	Off, Definite Time, Custom made, IEEE square law	Definite Time

Integer parameters

Table 1-2 The integer parameters of the overexcitation protection function

PARAMETER NAME	TITLE	UNIT	MIN	MAX	STEP	DEFAULT
Starting value of the IEEE characteristic						
VPH24_EmaxCont_IPar_	Start U/f LowSet	%	80	140	1	110
Flux value above which the IEEE and custom-made characteristics are replaced by the declared minimum time. It is also the setting for definite time operation.						
VPH24_Emax_IPar_	Start U/f HighSet	%	100	140	1	140
Time multiplier for IEEE characteristic						
VPH24_k_IPar	Time Multiplier		1	100	1	10
First point of custom characteristic						
VPH24_E1_IPar	U/f value 1	%	100	140	1	105
Second point of custom characteristic						
VPH24_E2_IPar	U/f value 2	%	100	140	1	110
Third point of custom characteristic						
VPH24_E3_IPar	U/f value 3	%	100	140	1	115

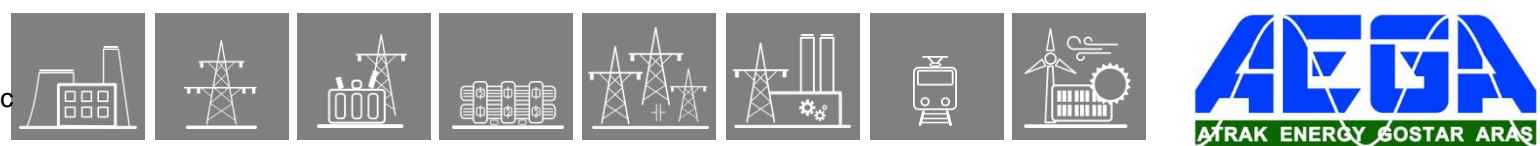

Fourth point of custom characteristic						
VPH24_E4_IPar	U/f value 4	%	100	140	1	120
Fifth point of custom characteristic						
VPH24_E5_IPar	U/f value 5	%	100	140	1	125
Sixth point of custom characteristic						
VPH24_E6_IPar	U/f value 6	%	100	140	1	130
Seventh point of custom characteristic						
VPH24_E7_IPar	U/f value 7	%	100	140	1	135

Float parameters

Table 1-3 Timer parameters of the overexcitation protection function

PARAMETER NAME	TITLE	UNIT	MIN	MAX	STEP	DEFAULT
Minimum time delay for the IEEE characteristic						
VPH24_MinDel_FPar_	Min Time Delay	sec	0.5	60.0	0.1	10.0
Maximum time delay for the IEEE characteristic						
VPH24_MaxDel_FPar_	Max Time Delay	sec	300	8000	1	3000
Reset time delay for the inverse characteristics (IEEE and Custom)						
VPH24_CoolDel_FPar_	Cooling Time	sec	1	8000	1	1000
Time delay for definite time characteristic						
VPH24_DTDelay_FPar_	DT Time Delay	sec	0.5	60.0	0.1	10.0
Time delay for first point of custom characteristic						
VPH24_Delay1_FPar_	Delay1	sec	1	8000	1	1000
Time delay for second point of custom characteristic						
VPH24_Delay2_FPar_	Delay2	sec	1	8000	1	900
Time delay for third point of custom characteristic						
VPH24_Delay3_FPar_	Delay3	sec	1	8000	1	800
Time delay for fourth point of custom characteristic						
VPH24_Delay4_FPar_	Delay4	sec	1	8000	1	700
Time delay for fifth point of custom characteristic						
VPH24_Delay5_FPar_	Delay5	sec	1	8000	1	600
Time delay for sixth point of custom characteristic						
VPH24_Delay6_FPar_	Delay6	sec	1	8000	1	500
Time delay for seventh point of custom characteristic						
VPH24_Delay7_FPar_	Delay7	sec	1	8000	1	400

2.1.2.6. The decision logic

The decision logic module combines the status signals, binary and enumerated parameters to generate the trip command of the function.

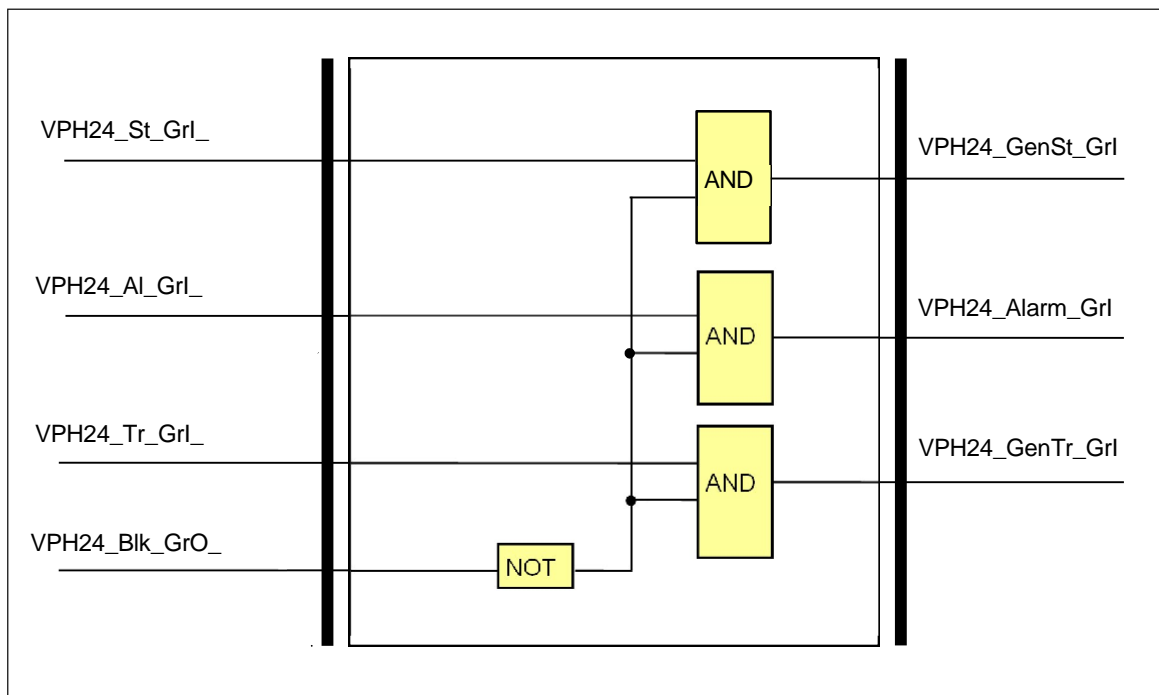

Figure 1-7 The logic scheme of the overexcitation protection function

Binary status signals

The overexcitation protection function has two **binary input signals**, which serve the purpose of disabling the function and resetting the thermal counter. **The conditions of disabling or resetting are defined by the user, applying the graphic equation editor.**

Table 1-4 The binary input signals of the overexcitation protection function

BINARY STATUS SIGNAL	EXPLANATION
VPH24_Block_GrO_	Output status of a graphic equation defined by the user to disable the overexcitation protection function.
VPH24_Reset_GrO_	Output status of a graphic equation defined by the user to reset the thermal counter

The **binary output status signals** of the overexcitation protection function are listed in **Error! Reference source not found.**

Table 1-5 The binary output status signals of the overexcitation protection function

BINARY OUTPUT SIGNALS	SIGNAL TITLE	EXPLANATION
VPH24_GenSt_Grl_	General Start	General starting of the function
VPH24_Alarm_Grl_	Alarm	Alarm generated 10sec after General Start
VPH24_GenTr_Grl_	General Trip	General trip command of the function

2.1.2.6.1. Overexcitation function overview

The graphic appearance of the function block of the overexcitation protection function is shown on Figure 2-1. The block shows all binary input and output status signals which are applicable in the graphic equation editor.

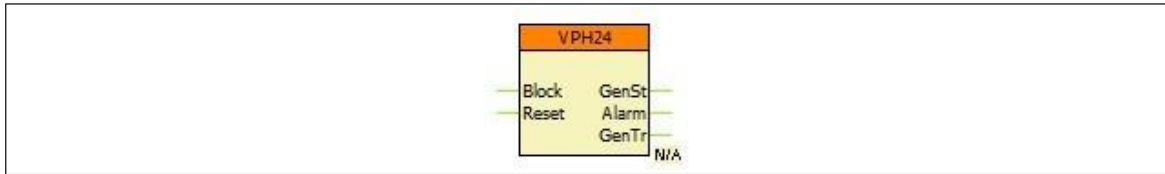

Figure 2-1 The graphic appearance of the function block of the overexcitation protection function

2.1.2.6.1.1. Settings

2.1.2.6.1.1.1. Parameters

Table 2-1 Parameters of the overexcitation protection function

TITLE	DIM	RANGE	STEP	DEFAULT	EXPLANATION
Operation	-	Off, Definite Time, Custom made, IEEE square law	-	Off	Enabling and selecting the desired characteristic of the overexcitation function
<i>Parameters related to the definite time and IEEE characteristics</i>					
Start U/f HighSet	%	100 – 140	1	140	Setting value for definite time operation. Also effective for Custom and IEEE characteristics as a fast stage.
Start U/f LowSet	%	80 – 140	1	110	Pick up value and starting point for the IEEE characteristic.
Time Multiplier	-	1 – 100	1	10	Time multiplier for IEEE characteristic.
Definite Time Delay	sec	0.5 – 60	0.1	10	Setting value for definite time operation. Also effective for Custom characteristic as a fast stage.
Min Time Delay	sec	0.5 – 60	0.1	10	Minimum time delay applicable for IEEE characteristic if the U/f ratio exceeds the value of Start U/f HighSet.
Max Time Delay	sec	300 – 8000	1	3000	Maximum time delay applicable for IEEE characteristic to limit the tripping time.
Cooling Time	sec	1 – 8000	1	1000	Cooling time for the Custom and IEEE characteristics.

<i>Parameters related to the custom characteristic</i>					
U/f value1	%	100 – 140	1	105	First point and pickup setting of the Custom characteristic.
U/f value2	%	100 – 140	1	110	Second point of the Custom characteristic.
U/f value3	%	100 – 140	1	115	Third point of the Custom characteristic.
U/f value4	%	100 – 140	1	120	Fourth point of the Custom characteristic.
U/f value5	%	100 – 140	1	125	Fifth point of the Custom characteristic.
U/f value6	%	100 – 140	1	130	Sixth point of the Custom characteristic.
U/f value7	%	100 – 140	1	135	Seventh point of the Custom characteristic.
Delay1	sec	1 – 8000	1	1000	Time delay for the first point of Custom characteristic.
Delay2	sec	1 – 8000	1	900	Time delay for the second point of Custom characteristic.
Delay3	sec	1 – 8000	1	800	Time delay for the third point of Custom characteristic.
Delay4	sec	1 – 8000	1	700	Time delay for the fourth point of Custom characteristic.
Delay5	sec	1 – 8000	1	600	Time delay for the fifth point of Custom characteristic.
Delay6	sec	1 – 8000	1	500	Time delay for the sixth point of Custom characteristic.
Delay7	sec	1 – 8000	1	400	Time delay for the seventh point of Custom characteristic.

2.1.2.6.2. Characteristics

The function offers three different characteristics to satisfy the different user requirements.

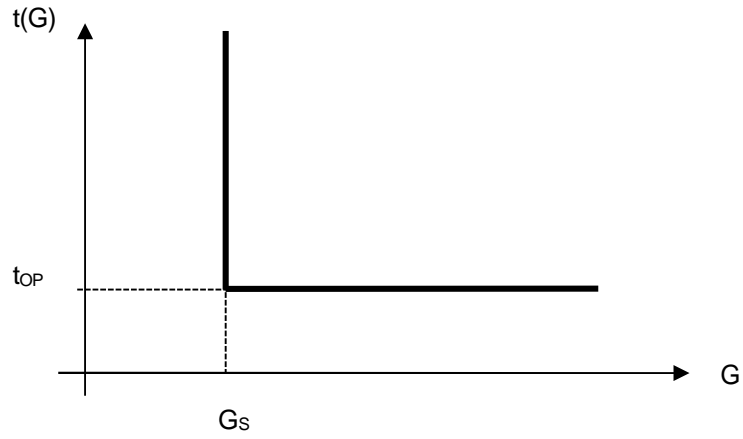

Figure 2-2 Overexcitation independent time characteristic

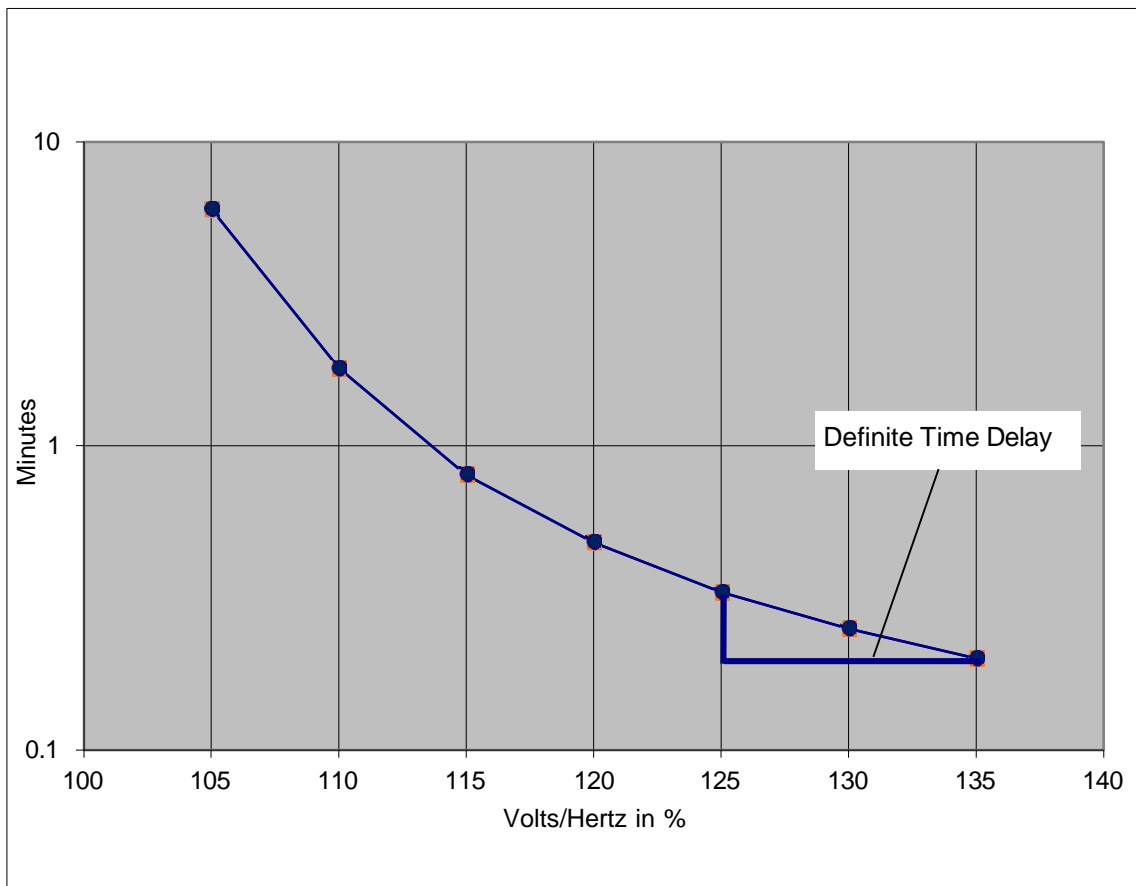

Figure 2-3 Custom inverse time characteristics

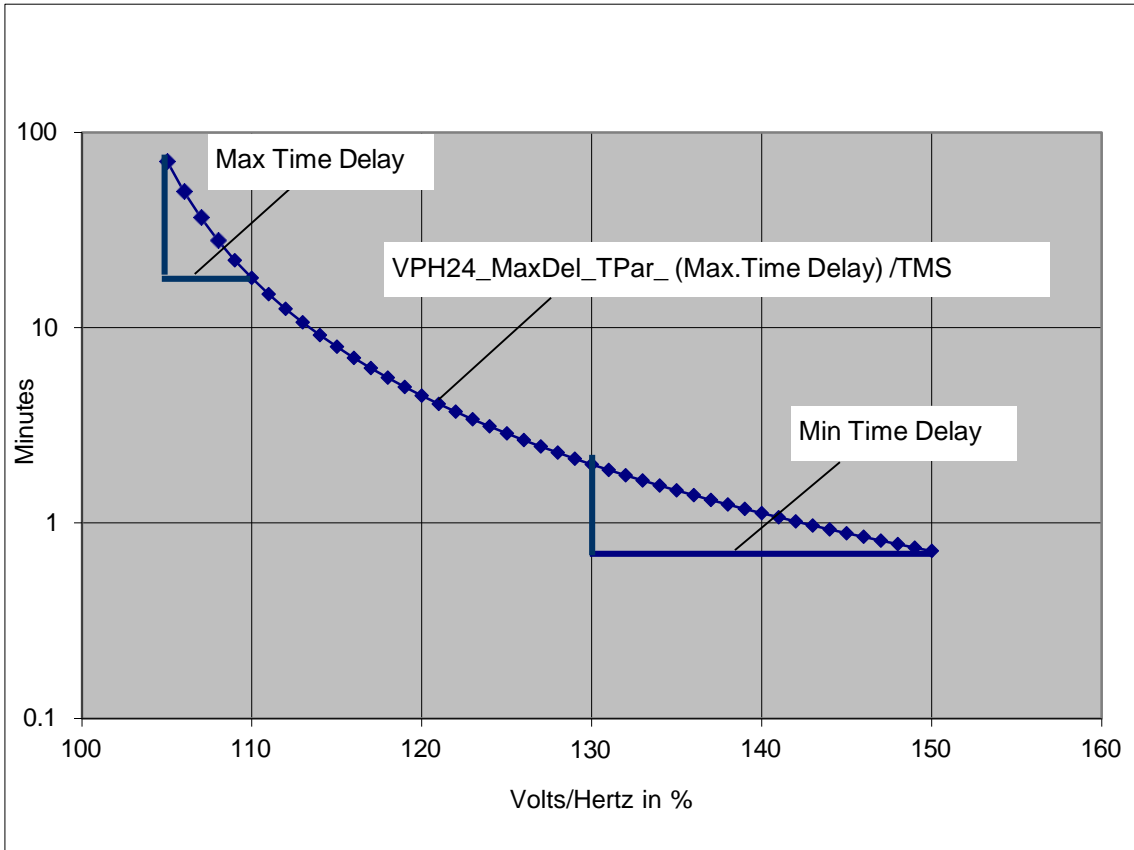

Figure 2-4 IEEE standard inverse time characteristics

2.1.2.7. Function I/O

This section describes briefly the analogue and digital inputs and outputs of the function block.

2.1.2.7.1. Analogue inputs

The function uses only one calculated line voltage, where the line voltage calculation is based on phase voltage sampled values.

2.1.2.7.2. Analogue outputs (measurements)

The measured value of the overexcitation protection function is listed in the table below.

Table 2-2 The measured analogue value of the overexcitation protection function

MEASURED VALUE	DIMENSION	EXPLANATION
Actual Heat	%	Actual heat of the protected object. 100% corresponds to the inverse time characteristic trip value.

Remark: Following a successful thermal trip operation, the counter starts a linear count-down from 100% to zero. Duration of the count-down corresponds to the cooling time parameter.

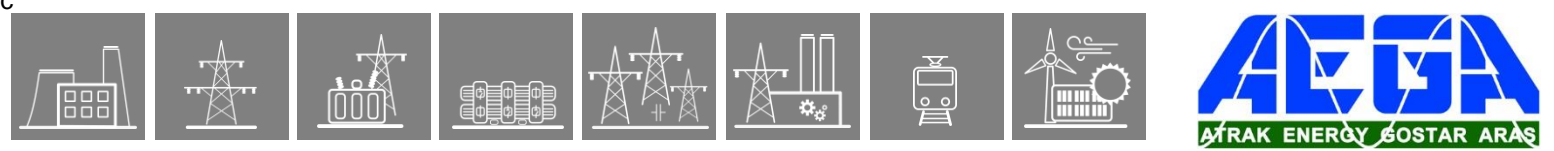

2.1.2.8. Technical data

Table 2-7 Technical data of the overexcitation protection function

FUNCTION	VALUE
U/f pick up accuracy	< 1%
U/f drop off ratio	0.95
DT and custom char. time delay accuracy	< 1%
IEEE char. time delay accuracy	< 5%

2.1.2.8.1. Notes for testing

Alarm output of the function block is generated after a fix 10s following the Start signal.



When testing the custom or IEEE characteristics, attention must be paid to the value of the Actual Heat. To get an accurate trip time measurement, the Actual Heat shall be reset to zero before the test. This can be done with the reset input of the function itself, or by clicking the set parameters button.

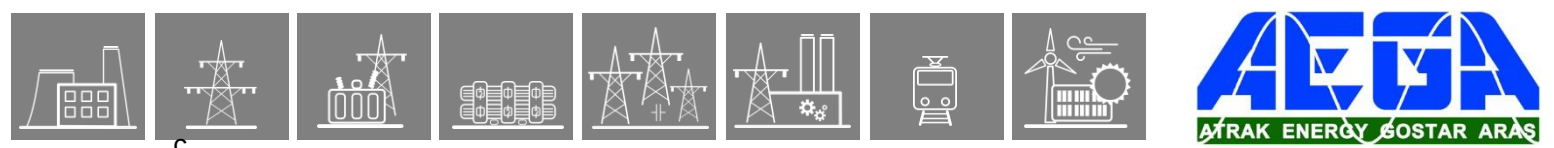

C

2.1.3. Generator synchronizer function

2.1.3.1. Application

The GENSYN25 generator synchronizer function automatically controls the procedure to connect a generator to the network. The voltage and the speed of the generator is regulated to match the voltage and the frequency of the network. During this procedure, the voltage magnitude, the frequency and the phase angle of the generator and those of the network are continuously evaluated. If the voltage and frequency difference between the network and the generator is within the defined limits, then the close command to the circuit breaker is generated in the right moment, considering the closing time of the circuit breaker, to connect the generator to the system with minimal phase angle difference.

The function is based on the SYN25 synchro-check/synchro-switch function (the description is the document "*Synchro check, synchro switch function block description*"). The applied mode is "synchro switch" mode. This function is extended with command function to increase/decrease voltage and speed of the generator. These commands are generated to meet the basic switching requirements.

2.1.3.2. Mode of operation

The circuit breaker of the generator may be closed only if the voltages at both sides of the circuit breaker are in approximate synchronous position. This can prevent damages of the generator caused by switching at deviating voltage vectors.

The basis of the switching decision is the comparison of the voltage transformer signals at both sides of the circuit breaker.

The conditions for safe closing are as follows:

- The difference of the voltage magnitudes is below the declared limit,
- The difference of the frequencies is below the declared limit and
- The angle difference between the voltages on both sides of the circuit breaker is within the declared limit.

The voltage difference can be minimized by pulses sent to the voltage controller, the frequency (speed) difference can be minimized by pulses to the speed controller. (Both functions can be enabled by dedicated binary parameters: "U matching" and "F matching".)

The measured values are compared with the magnitude difference and frequency difference parameters: "Udiff SW Ena" and "Udiff Max" for voltage control and "FrDiff SW Ena" and "FrDiff Max" for frequency control. The function starts only if these values are within the defined broader band values. These condition can be satisfied by manual control commands, this function is not in the scope of this function. After starting, the fine tuning is performed automatically. Additionally the phase angle difference is also considered. The close command ("SW Cmd") is generated in due time, considering the operating time of the circuit breaker. To avoid the operation of the "reverse power protection" function (independent function) after closing the circuit breaker, connecting is allowed only if the speed of the generator is above the frequency of the network voltage.

2.1.3.3. Connection to the primary circuits

The function block is connected to the primary circuits as it is indicated by the Figure 1-1 below.

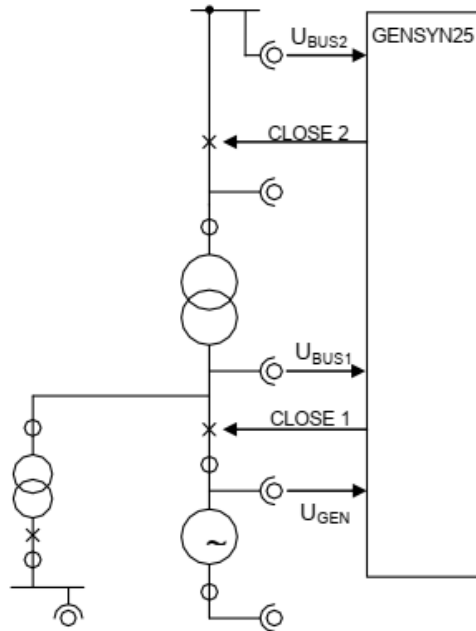

Figure 1-1 Principal scheme of connection to the primary circuits

In this typical arrangement the synchronizing procedure can apply any of the circuit breakers: the circuit breaker at the generator voltage level or the circuit breaker at the high voltage side of the unit transformer.

If the circuit breaker at the generator voltage level is applied then the generator voltage is compared to the signal of the U_{BUS1} voltage transformer, in the second case it is compared to the signal of the U_{BUS2} voltage transformer.

The signal connected to the “BusSel” binary input of the function block indicates which option is applied. When connecting a logic TRUE signal, the U_{BUS2} measurement gets active. When this input signal is logic FALSE then U_{BUS1} measurement is active. The selected option is indicated by the output binary signals “Bus1Act” or “Bus2Act” of the function block. The function block has a single close command only: “SWCmd”. It is the task of the graphic logic editor function to direct this close command to the appropriate circuit breaker.

The turn’s ratio of the voltage transformers Bus1 and Bus2 need not be identical to that of the U_{GEN} voltage transformer. Additionally, in case of Bus2, the turn’s ratio of the unit transformer need also be considered. To cover all possibilities, for the Bus1 and Bus2 measurements the function block provides correction parameters to match the voltages to the generator side voltage. These independent parameters are “TR1 AmplCorr” and “TR2 AmplCorr” factors respectively.

The single line diagram of Figure 1-1 shows that the Bus2 voltage can be phase shifted due to the connection group of the unit transformer. To compensate this phase shift, the parameters “TR1 phase shift” and “TR2 phase shift” should be set according to the connection group of the transformer. Positive angles mean that the generator voltage leads the bus voltage. As an example, in case of Yd11 connection group, if both voltage measurements are in the same phase then the correct parameter setting is 30 degrees.

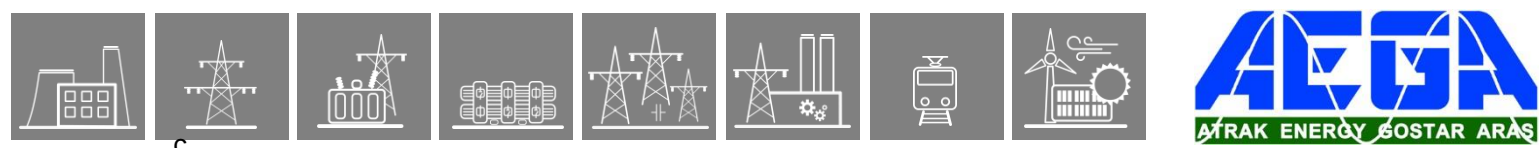

C

2.1.3.4. Connecting the VT4 voltage input

Due to the frequency measurement restrictions of the VT4 voltage input block, the generator voltage is connected to U1, Bus1 is connected to U2 and Bus2 is connected to U4 analog inputs. In the vector diagrams displayed, the reference voltage (that with fix phase angle zero degrees) is always U1. At synchronizing, the generator voltage should be always available.

2.1.3.5. Starting the synchronizing procedure

The synchronizing procedure is triggered by the binary signal connected to the “Start” input of the function block. This is to be arranged in the graphic logic editor. The conditions for starting are as follows:

- the function is not blocked (“Blk” binary input gets logic FALSE signal),
- there is no disabling signal received from the voltage transformer supervising miniature circuit breakers (“VTSGen”, “2VTSBus1” and “VTSBus2” binary inputs of the function block). (Only the active side of Bus1 or Bus2 measurements is considered.)
- both generator voltage and network voltage are above the “Umin” parameter setting limit.
- the voltage difference is below the level set by parameter “UDiff max” and
- the frequency difference is below the level set by parameter “FrDiff max”.

The possibility to start the function is indicated by the binary output „Ready” of the function block.

Closing the circuit breaker is possible only if the voltage difference is below the narrower “UDiff. eng.” limit and the frequency difference is below the narrower “FrDiff. eng.” level. Additionally, the frequency of the generator should be 40 mHz higher than that of the network.

The started state is indicated by the “InProgr” binary output of the function block. This state is terminated at Close command generation, or at timeout of the “TimeOut” timer, or at the moment when the “Cancel” binary input of the function block gets a logic TRUE signal.

2.1.3.6. Controlling the frequency and the voltage magnitude

The controlling of the voltage and frequency can be disabled individually by dedicated binary parameter setting (“UMatching” and “FMatching” respectively). If any of them is not enabled then the related “...Max” and “...SWEna” values should be set to the same value.

After starting the function block, the frequency difference and the voltage difference is controlled to get within the rage defined by parameters “FrDiff. SWEna” and “UDiff. SWEna” respectively. This state enables close command generation.

Figure 1-2 shows the limits for frequency difference, Figure 1-3 shows the limits for voltage difference. The broader limits indicate when the synchronization procedure can be started, the narrower range enables close command generation for the circuit breaker.

Figure 1-2 shows that starting is possible if the frequency difference is between “FrDiff Max”. and –“FrDiff Max”. To reach this state, manual control is expected, this function is not in the scope of this function.

The close command can be generated if the frequency difference is below the level “FrDiff. SWEna” and additionally the frequency of the generator is at least 40 mHz higher than that of the network. The expected value of the automatic frequency control is the center of the frequency range: $(FrDiff. SWEna + 40mHz)/2$.

C

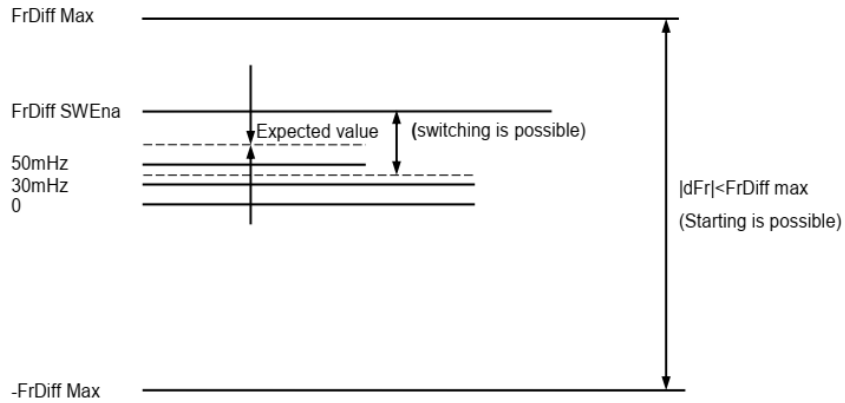

Figure 1-2 Limits for frequency difference

Figure 1-3 below shows the limits for the voltage control.

The automatic control function can be started if the voltage difference is within the range “UDiff Max” and “-UDiff Max”, and additionally both voltages are above the limit, defined by parameter “U min”. To reach this state, manual control is expected.

The close command can be generated if the voltage difference is within the range “UDiff. SWEna” and “-UDiff. SWEna”. The expected value of the automatic voltage control is the zero voltage difference.

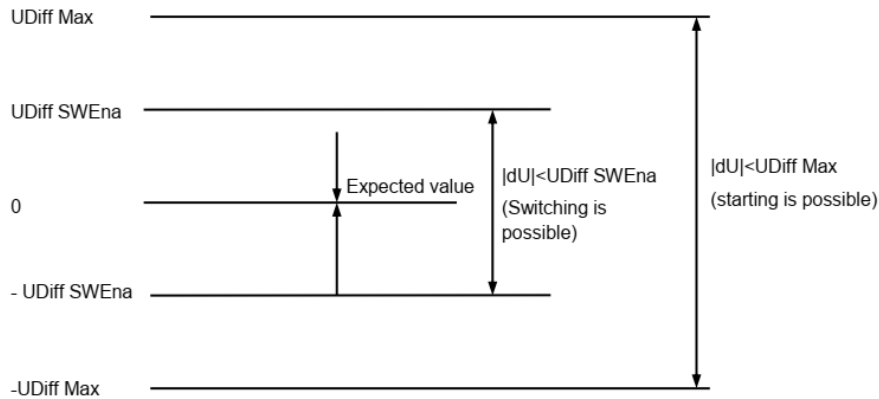
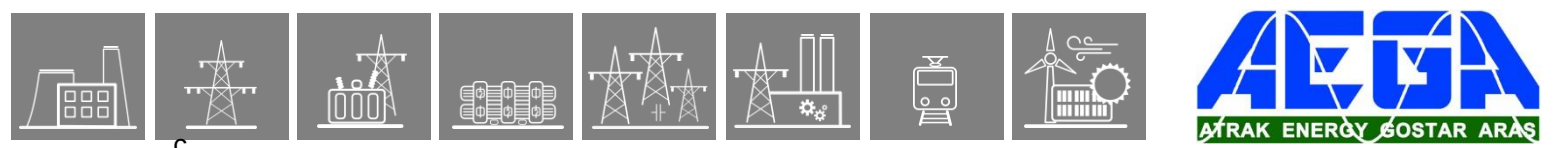

Figure 1-3 Limits for voltage difference

After starting, the control of the voltage and the frequency is performed by pulses. For voltage control, the duration of the pulse is related to the voltage difference by the setting value “dt/dU factor”. This factor is expressed in [ms/%]. This means that each percent of changing the voltage needs a pulse with duration of the numerical value in milliseconds.

In case of perfect setting, a single pulse results the expected voltage value. To avoid swings however, it is advised to approximate this value by smaller steps during the first commissioning. The duration of the generated pulses can be limited from both sides, using the parameters “Uimp min” and “Uimp max”. If the controlling pulse is transmitted via auxiliary relays then the minimal pulse duration should be set to allow operation of these auxiliary relays.

Controlling the frequency (speed) is also performed by pulses. The duration of the pulse is related to the frequency difference by the setting value “dt/df factor”. This factor is expressed in



C

[ms/Hz]. This means that 1 Hz of changing the frequency needs a pulse with duration of the numerical value in milliseconds. In case of perfect setting, a single pulse results the expected frequency value. To avoid swings however it is advised to approximate this value from lower steps during the first commissioning. The duration of the generated pulses can be limited from both sides, using the parameters “Flmp min” and “Flmp max”. If the controlling pulse is transmitted via auxiliary relays then the minimal pulse duration should be set to allow operation of these auxiliary relays.

The effect of the pulses is not the immediate change of the voltage or frequency. To leave time to stabilize the final value, at the end of the longer pulse (frequency or voltage changing command) a timer is started with setting “Stabilization time”. If it is needed, the subsequent control pulse is generated only after expiry of this time.

2.1.3.7. Connecting the generator parallel to the network

Based on the detected frequency difference and the circuit breaker operated time (defined as parameter “Breaker Time”), the phase angle can be calculated. If the close command is generated at that phase angle, then the circuit breaker will close at synchronous position. The algorithm generates the close command, if the angle difference is decreasing and it is at the calculated value. If at the moment of starting the angle is below the calculated value then the command is generated at the subsequent revolution only.

C

2.1.3.8. Technical summary

2.1.3.8.1. Technical data

Function	Range	Accuracy in the effective range
Rated Voltage Un	100/200V, parameter setting	
Voltage effective range	10-110 % of Un	±1% of Un
Frequency	47.5 – 52.5 Hz	±10 mHz
Phase angle		±3 °
Operate time	Setting value	±3 ms

Table 2-1 Technical data of the generator synchronizer function

2.1.3.8.2. Parameters

Enumerated parameter

Parameter name	Title	Selection range	Default
Mode of operation			
SYN25_OperM_EPar_	Operation	On, Off	Off

Table 2-2 Enumerated parameter of the generator synchronizer function

Binary parameters

Parameter name	Title	Default	Explanation
Voltage control selection			
SYN25_UMatch_BPar_	U matching	1	“0” means that no voltage control is applied
Frequency control selection			
SYN25_FMatch_BPar_	F matching	1	“0” means that no frequency control is applied

Table 2-3 Binary parameters of the generator synchronizer function

C

Integer parameters

Parameter name	Title	Unit	Min	Max	Step	Default
Voltage minimum, needed for synchronization						
SYN25_LiveU_IPar_	U min	%	60	110	1	70
Phase shift at Bus1						
SYN25_U2Rot_IPar_	TR1 phase shift	deg	-180	180	1	0
Phase shift at Bus2						
SYN25_U4Rot_IPar_	TR2 phase shift	deg	-180	180	1	0
Slope of voltage control						
SYN25_Ufactor_IPar_	dt/dU factor	ms/%	100	10000	1	200
Slope of frequency control						
SYN25_Ffactor_IPar_	dt/df factor	ms/Hz	100	60000	1	200
Maximum voltage difference for switching						
SYN25_SwUdM_IPar_	UDiff SWEna	%	2	20	1	10
Maximum voltage difference for starting						
SYN25_SwUMax_IPar_	UDiff Max	%	5	30	1	10
Timeout for switching						
SYN25_TimeOut_IPar_	Timeout	sec	10	600	1	30
Stabilization time after control command generation						
SYN25_StabTime_IPar_	Stabilization time	sec	1	300	1	5

Table 2-4 Integer parameters of the generator synchronizer function

Floating point parameters

Parameter name	Title	Unit	Min	Max	Step	Default
Voltage correction factor for Bus1 measurement						
SYN25_U2AmplCorr_FPar_	TR1 AmplCorr		0,500	2,000	0,001	1
Voltage correction factor for Bus2 measurement						
SYN25_U2AmplCorr_FPar_	TR2 AmplCorr		0,500	2,000	0,001	1
Maximum frequency difference for switching						
SYN25_SwFrDM_FPar_	FrDiff SWEna	Hz	0,10	1,00	0,01	0,20
Maximum frequency difference for starting						
SYN25_SwFMax_FPar_	FrDiff Max	Hz	0,10	5,00	0,01	2,00

Table 2-5 Floating point parameters of the generator synchronizer function

Timer parameters

Parameter name	Title	Dim	Min	Max	Step	Default
Circuit breaker operating time for closing						
SYN25_CBTrav_TPar_	Breaker time	ms	30	500	1	80
Pulse command duration						
SYN25_SwPu_TPar_	Close Pulse	ms	10	60000	1	1000
Minimum duration of voltage control command						
SYN25_Umin_TPar_	UImp min	ms	100	30000	1	500
Maximum duration of voltage control command						
SYN25_Umax_TPar_	UImp max	ms	100	30000	1	10000
Minimum duration of frequency control command						
SYN25_Fmin_TPar_	FImp min	ms	100	30000	1	500
Maximum duration of frequency control command						
SYN25_Fmax_TPar_	FImp max	ms	100	30000	1	10000

Table 2-6 Timer parameters of the generator synchronizer function

2.1.3.8.3. Binary output status signals

Binary output status signal	Title	Explanation
SYN25_SWCmd_Grl_	SWCmd	Close command for the circuit breaker, generated in due time before synchron position of the voltage vectors
SYN25_Ready_Grl_	Ready	The function can be started
SYN25_InPrgr_Grl_	InPrgr	Synchronization in progress
SYN25_UUp_Grl_	U Up	Impulse for increasing the voltage
SYN25_UDown_Grl_	U Down	Impulse for decreasing the voltage
SYN25_FUp_Grl_	F Up	Impulse for increasing the frequency
SYN25_FDown_Grl_	F Down	Impulse for decreasing the frequency
SYN25_Bus1Act_Grl_	Bus1 Act	Active measurements at Bus1
SYN25_Bus2Act_Grl_	Bus2 Act	Active measurements at Bus2

Table 2-7 Binary output status signals of the generator synchronizer function

2.1.3.8.4. Binary input status signals

The synchro check / synchro switch function has binary input status signals. **The conditions are defined by the user, applying the graphic equation editor.**

The **binary input status signals** of the synchro check / synchro switch function are listed in Table 2-8 below.

Binary input status signal	Title	Explanation
SYN25_Blk_GrO_	Blk	Blocking signal of the function
SYN25_BusSel_GrO_	BusSel	If this signal is logic TRUE, then the voltage of Bus2 is selected for evaluation
SYN25_VTSBlk_GrO_	VTS Gen	Blocking signal of the voltage transformer supervision function evaluating the generator voltage
SYN25_Bus1VTSBlk_GrO_	VTS Bus1	Blocking signal of the voltage transformer supervision function evaluating the Bus1 voltage
SYN25_Bus2VTSBlk_GrO_	VTS Bus2	Blocking signal of the voltage transformer supervision function evaluating the Bus2 voltage
SYN25_SwStM_GrO_	Start	Start signal initiating the synchronization procedure
SYN25_CancelM_GrO_	Cancel	Signal to interrupt (cancel) the synchronization procedure

Table 2-8 Binary input status signals of the generator synchronizer function

C

2.1.3.9. The symbol of the function block

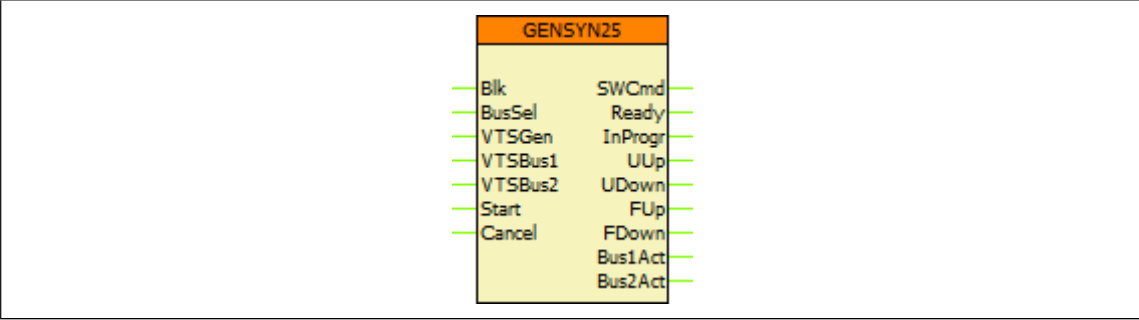
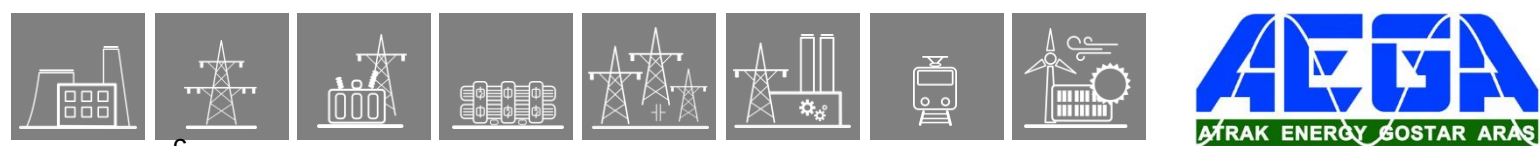

Figure 2-1 The function block in the graphic logic editor

The names of the input and output signals are parts of the “Binary status signal” names listed in Table 2-7 and Table 2-8.



C

2.1.4. Synchro check / synchro switch function

2.1.4.1. Application

Several problems can occur in the electric power system if the circuit breaker closes and connects two systems operating asynchronously. The high current surge can cause damage in the interconnecting elements, the accelerating forces can overstress the shafts of rotating machines or the actions taken by the protective system can result in the unwanted separation of parts of the electric power system.

To prevent such problems, this function checks whether the systems to be interconnected are operating synchronously. If yes, then the close command is transmitted to the circuit breaker. In case of asynchronous operation, the close command is delayed to wait for the appropriate vector position of the voltage vectors on both sides of the circuit breaker. If the conditions for safe closing cannot be fulfilled within an expected time, then closing is declined.

The conditions for safe closing are as follows:

- The difference of the voltage magnitudes is below the declared limit,
- The difference of the frequencies is below the declared limit and
- The angle difference between the voltages on both sides of the circuit breaker is within the declared limit.

2.1.4.2. Mode of operation

The function processes both automatic reclosing and manual close commands.

The limits for automatic reclosing and manual close commands can be set independently of each other.

The function compares the voltage of the line and the voltage of one of the bar sections (Bus1 or Bus2). The bus selection is made automatically based on a binary input signal defined by the user applying the graphic equation editor.

As to voltages: any phase-to-ground or phase-to-phase voltage can be selected.

The function processes the signals of the voltage transformer supervision function and enables the close command only in case of plausible voltages.

There are three modes of operation:

- Energizing check:
 - Dead bus, live line,
 - Live bus, dead line,
 - Any Energizing Case (including Dead bus, dead line).
- Synchro check (Live line, live bus)
- Synchro switch (Live line, live bus)

If the conditions for “Energizing check” or “Synchro check” are fulfilled, then the function generates the release command, and in case of a manual or automatic close request, the close command is generated.

If the conditions for energizing and synchronous operation are not met when the close request is received, then synchronous switching is attempted within the set time-out. In this case, the rotating vectors must fulfill the conditions for safe switching within the declared waiting time: at the moment the contacts of the circuit breaker are closed, the voltage vectors must match each other with appropriate accuracy. For this mode of operation, the expected operating time of the circuit breaker must be set as a parameter value, to generate the close command in advance taking the relative vector rotation into consideration.

The started checking procedure can be interrupted by a cancel command defined by the user in the graphic equation editor.

In “bypass” operation mode, the function generates the release signals and simply transmits the close command.

2.1.4.3. Structure of the synchro check/synchro switch function

The synchro check/synchro switch function contains two kinds of software blocks (See Figure 1-1):

- SYN25_Com is a common block for manual switching and automatic switching
- SYN25_EVA is an evaluation block, duplicated for manual switching and for automatic switching

These software blocks are explained in detail below.

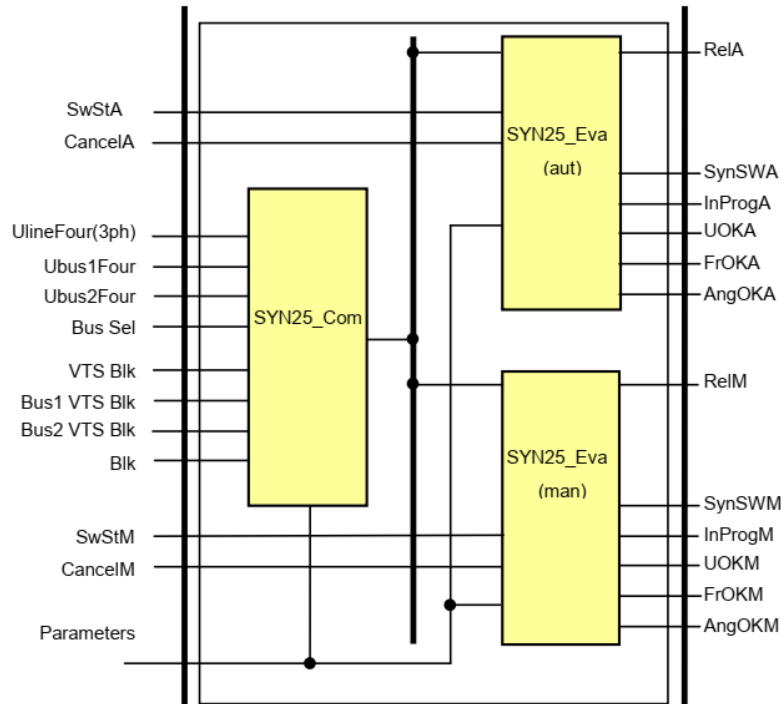
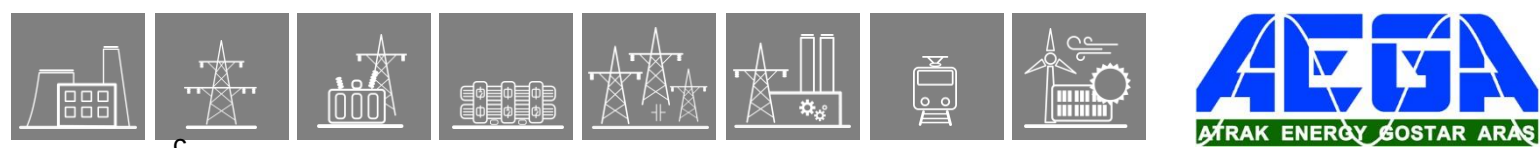

Figure 1-1 Structure of the synchro check/synchro switch function

Analog input signals

The function processes the result of three Fourier calculation blocks. These modules process the following voltages of the line and those of two bus sections.

- **UlineFour(3ph)** the Fourier components of the three phase voltages. The module selects one phase or one line-to-line voltage based on this set to be matched to the bus voltages.
- **Ubus1Four** and **Ubus2Four** the Fourier components characteristic for the bus sections. These can be a phase voltages of the same phase as it is selected from UlineFour(3ph) or matching line-to-line voltages. The selection is made by the parameter value of SYN25_VoltSel_EPar_ (Voltage select) (see Table 1-4). Between the two bus sections, a binary input signal controls the selection SYN25_BusSel_GrO_ (Bus select).



C

Binary input status signals

The synchro check / synchro switch function has binary input signals. **The conditions are defined by the user, applying the graphic equation editor.**

The **binary input status signals** of the synchro check / synchro switch function are listed in Table 1-1.

Binary status signal	Title	Explanation
SYN25_BlK_GrO_	Block	Blocking signal of the function
SYN25_BusSel_GrO_	Bus select	If this signal is logic TRUE, then the voltage of Bus2 is selected for evaluation
SYN25_VTSBlk_GrO_	VTS Block	Blocking signal of the voltage transformer supervision function evaluating the line voltage
SYN25_Bus1VTSBlk_GrO_	VTS Bus1 Block	Blocking signal of the voltage transformer supervision function evaluating the Bus1 voltage
SYN25_Bus2VTSBlk_GrO_	VTS Bus2 Block	Blocking signal of the voltage transformer supervision function evaluating the Bus2 voltage
SYN25_SwStA_GrO_	SySwitch Auto	Switching request signal initiated by the automatic reclosing function
SYN25_CancelA_GrO_	Cancel Auto	Signal to interrupt (cancel) the automatic switching procedure
SYN25_SwStM_GrO_	SySwitch Manual	Switching request signal initiated by manual closing
SYN25_CancelM_GrO_	Cancel Manual	Signal to interrupt (cancel) the manual switching procedure

Table 1-1 The binary input status signals of the synchro check / synchro switch function

The function is disabled if

- The binary input SYN25_BlK_GrO_ (Block) signal is TRUE
- The voltage transformer supervision circuit for the line voltage blocks the operation SYN25_VTSBlk_GrO_ (VTS Block)
- The voltage transformer supervision circuit for the selected bus section blocks the operation SYN25_Bus1VTSBlk_GrO_ (VTS Bus1 Block) or SYN25_Bus2VTSBlk_GrO_ (VTS Bus2 Block)
- Parameter settings disable the operation (see details below)

The function can be started by the following binary input signals:

- SYN25_SwStA_GrO_ (SySwitch Auto) automatic starting
- starting SYN25_SwStM_GrO_ (SySwitch Manual) manual starting

If the function is in operation, then the process can be stopped (canceled) by the following binary input signals:

- SYN25_CancelA_GrO_ (Cancel Auto) canceling the automatic operation.
- operation SYN25_CancelM_GrO_ (Cancel Manual) canceling the manual operation.

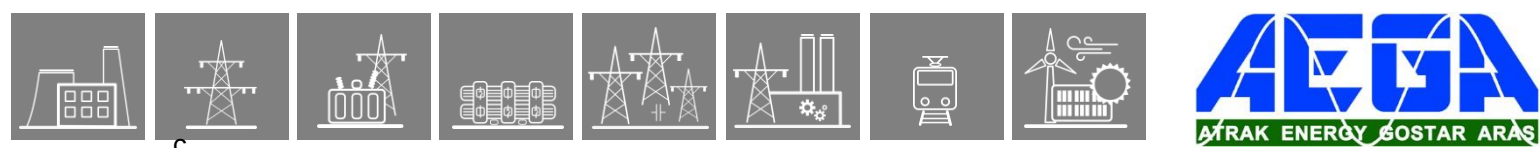

C

The **binary output status signals** of the synchro check / synchro switch function are listed in Table 1-2.

Binary status signal	Title	Explanation
SYN25_RelA_Grl_	Release Auto	Releasing the close command initiated by the automatic reclosing function
SYN25_InProgA_Grl_	SynInProgr Auto	Switching procedure is in progress, initiated by the automatic reclosing function
SYN25_SynSWA_Grl_ *	Syn Cmd Auto *	Switching command initiated by the automatic reclosing function *
SYN25_UOKA_Grl_	Udiff OK Auto	The voltage difference is appropriate for automatic closing command
SYN25_FrOKA_Grl_	FreqDiff OK Auto	The frequency difference is appropriate for automatic closing command, evaluated for synchro-check **
SYN25_AngOKA_Grl_	Angle OK Auto	The angle difference is appropriate for automatic closing command
SYN25_RelM_Grl_	Release Man	Releasing the close command, initiated by manual closing request
SYN25_InProgM_Grl_	SynInProgr Man	Switching procedure is in progress, initiated by the manual closing command
SYN25_SynSWM_Grl_ *	Syn Cmd Man *	Switching command initiated by the manual closing command *
SYN25_UOKM_Grl_	Udiff OK Man	The voltage difference is appropriate for manual closing command
SYN25_FrOKM_Grl_	FreqDiff OK Man	The frequency difference is appropriate for manual closing command, evaluated for synchro-check **
SYN25_AngOKM_Grl_	Angle OK Man	The angle difference is appropriate for manual closing command
SYN25_SynSW_Grl_ *	Syn Cmd *	Switching command, OR connection of manual and automatic closing*

* *This command can be assigned directly to an output contact (defined in the "L1 contact" menu of the EuroCap configuration software), it is not published for logic signal processing, using the graphic editor*

** *The frequency is evaluated using the weighted sum of the three phase voltages*

Table 1-2 The binary output status signals of the synchro check / synchro switch function

2.1.4.3.1. The common software block

In this paragraph the operation of the software block SYN25_Com of the Figure 1-1 is described. This block selects the appropriate voltages for processing and calculates the voltage difference, the frequency difference and the phase angle difference between the selected voltages. The magnitude of the selected voltages is passed for further evaluation, too. The structure of this software block is shown on Figure 1-2.

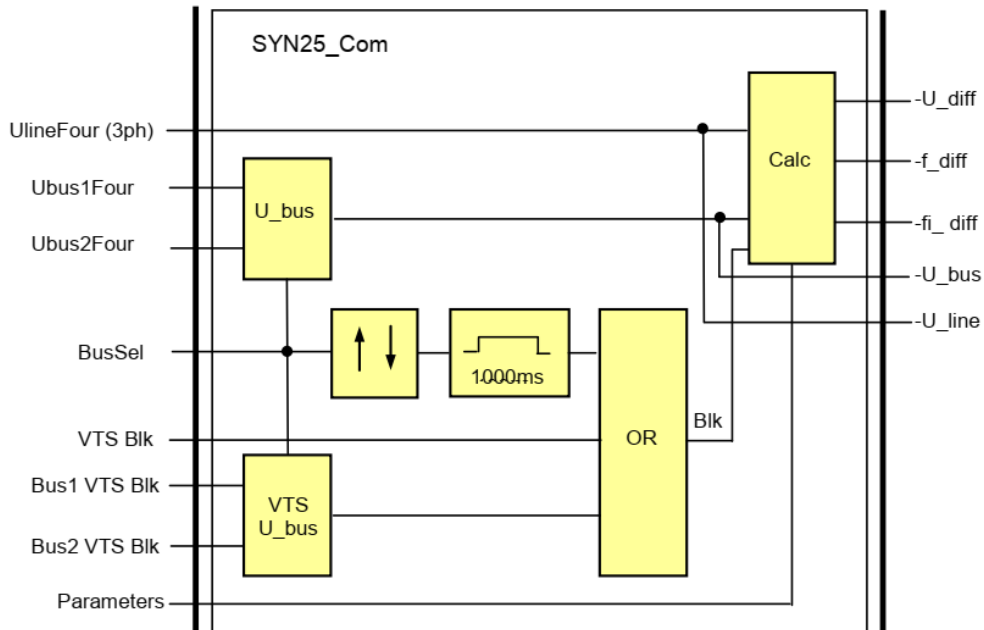

Figure 1-2 Structure of the common software block

Analog input signals

The function processes the result of three Fourier calculation blocks. These modules process the following voltages of the line and those of two bus sections.

- **UlineFour(3ph)** the Fourier components of the three phase voltages. The module selects one phase or one line-to-line voltage based on this set to be matched to the bus voltages.
- **Ubus1Four** and **Ubus2Four** the Fourier components characteristic for the bus sections. These can be a phase voltages of the same phase as it is selected from UlineFour(3ph) or matching line-to-line voltages. The selection is made by the parameter value of SYN25_VoltSel_EPar_ (Voltage select) (see Table 1-4). Between the two bus sections, a binary input signal controls the selection SYN25_BusSel_GrO_ (Bus select).

Binary input status signals

The synchro check / synchro switch function has binary input signals. **The conditions are defined by the user, applying the graphic equation editor.**

The **binary input status signals** of the synchro check / synchro switch function are listed in Table 1-3.

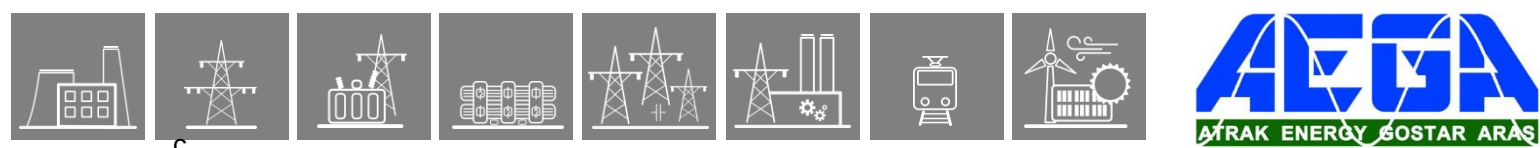

C

Binary status signal	Title	Explanation
SYN25_BusSel_GrO_	Bus select	If this signal is logic TRUE, then the voltage of Bus2 is selected for evaluation
SYN25_VTSBlk_GrO_	VTS Block	Blocking signal of the voltage transformer supervision function evaluating the line voltage
SYN25_Bus1VTSBlk_GrO_	VTS Bus1 Block	Blocking signal of the voltage transformer supervision function evaluating the Bus1 voltage
SYN25_Bus2VTSBlk_GrO_	VTS Bus2 Block	Blocking signal of the voltage transformer supervision function evaluating the Bus2 voltage
SYN25_Blk_GrO_	Block	Blocking signal of the function

Table 1-3 The binary input status signals of the common software block

The calculated or selected output values are:

- U_diff the magnitude difference between the selected voltages
- f_diff the frequency difference between the selected voltages
- fi_diff the phase angle difference between the selected voltages
- U_line the magnitude of the selected line voltage
- U_bus the magnitude of the voltage of the appropriate bus section

These values are further processed by the evaluation software blocks (See Figure 1-1).

The function is disabled if

- The binary input SYN25_Blk_GrO_ (Block) signal is TRUE
- The voltage transformer supervision circuit for the line voltage blocks the operation SYN25_VTSBlk_GrO_ (VTS Block)
- The voltage transformer supervision circuit for the selected bus section blocks the operation SYN25_Bus1VTSBlk_GrO_ (VTS Bus1 Block) or SYN25_Bus2VTSBlk_GrO_ (VTS Bus2 Block)
- Parameter settings disable the operation (see details below)

If the active bus section changes, then the function is dynamically blocked for 1000 ms; no release signal or switching command is generated.

This software block has no **binary output status signals**.

The processed line voltage is selected based on the preset parameter SYN25_VoltSel_EPar_ (Voltage select). The choice is: L1-N,L2-N,L3-N,L1-L2,L2-L3,L3-L1. The parameter value must match the input voltages received from the bus sections.

The active bus section is selected by the input signal SYN25_BusSel_GrO_ (Bus select). If this signal is logic TRUE, then the voltage of Bus2 is selected for evaluation.

The parameter of this software block is shown in Table 1-4 below:

Enumerated parameter

Parameter name	Title	Selection range	Default
Selection of the processed voltage			
SYN25_VoltSel_EPar_	Voltage Select	L1-N,L2-N,L3-N,L1-L2,L2-L3,L3-L1	L1-N

Table 1-4 The enumerated parameter of the common software block

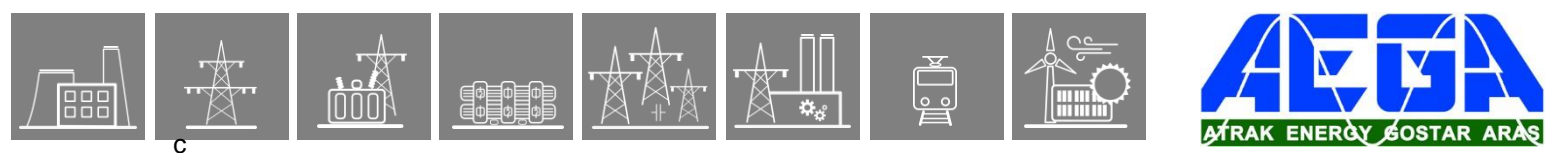

C

2.1.4.3.2. The evaluation software block

The operation of the software block SYN25_Eva of Figure 1-1 is described in this paragraph. This software block is applied separately for automatic and manual commands. This separation allows the application to use different parameter values for the two modes of operation.

The structure of the evaluation software block is shown in Figure 1-3.

Analog input signals

The function processes the results of the common block (See Paragraph 1.3.1).

The analog input values are:

- U_diff the magnitude difference between the selected voltages
- f_diff the frequency difference between the selected voltages
- fi_diff the phase angle difference between the selected voltages
- U_line the magnitude of the selected line voltage
- U_bus the magnitude of the voltage of the appropriate bus section

Binary input status signals

The evaluation software block has binary input status signals. **The conditions are defined by the user, applying the graphic equation editor.**

The **binary input status signals** of the evaluation software block are listed in Table 1-5

Binary status signal	Title	Explanation
SYN25_SwStA_GrO_	SySwitch Auto	Switching request signal initiated by the automatic reclosing function
SYN25_CancelA_GrO_	Cancel Auto	Signal to interrupt (cancel) the automatic switching procedure
SYN25_SwStM_GrO_	SySwitch Manual	Switching request signal initiated by manual closing
SYN25_CancelM_GrO_	Cancel Manual	Signal to interrupt (cancel) the manual switching procedure

Table 1-5 The binary input signal of the evaluation software block

The **binary output status signals** of the evaluation software block are shown in Table 1-6 for automatic starting and in Table 1-7 for manual starting.

C

Binary status signal	Title	Explanation
SYN25_RelA_Grl_	Release Auto	Releasing the close command initiated by the automatic reclosing function
SYN25_InProgA_Grl_	SynInProgr Auto	Switching procedure is in progress, initiated by the automatic reclosing function
SYN25_UOKA_Grl_	Udiff OK Auto	The voltage difference is appropriate for automatic closing command
SYN25_FrOKA_Grl_	FreqDiff OK Auto	The frequency difference is appropriate for automatic closing command, evaluated for synchro-check **
SYN25_AngOKA_Grl_	Angle OK Auto	The angle difference is appropriate for automatic closing command
SYN25_SynSWA_Grl_ *	Syn Cmd Auto *	Switching command initiated by the automatic reclosing function *

- *This command can be assigned directly to an output contact; it is not published for logic signal processing, using the graphic editor*
- ** *The frequency is evaluated using the weighted sum of the three phase voltages*

Table 1-6 The binary output status signals of the evaluation software block for automatic starting

Binary status signal	Title	Explanation
SYN25_RelM_Grl_	Release Man	Releasing the close command, initiated by manual closing request
SYN25_InProgM_Grl_	SynInProgr Man	Switching procedure is in progress, initiated by the manual closing command
SYN25_UOKM_Grl_	Udiff OK Man	The voltage difference is appropriate for manual closing command
SYN25_FrOKM_Grl_	FreqDiff OK Man	The frequency difference is appropriate for manual closing command, evaluated for synchro-check **
SYN25_AngOKM_Grl_	Angle OK Man	The angle difference is appropriate for manual closing command
SYN25_SynSWM_Grl_ *	Syn Cmd Man *	Switching command initiated by the manual closing command *

- *This command can be assigned directly to an output contact; it is not published for logic signal processing, using the graphic editor*
- ** *The frequency is evaluated using the weighted sum of the three phase voltages*

Table 1-7 The binary output status signals of the evaluation software block for manual starting

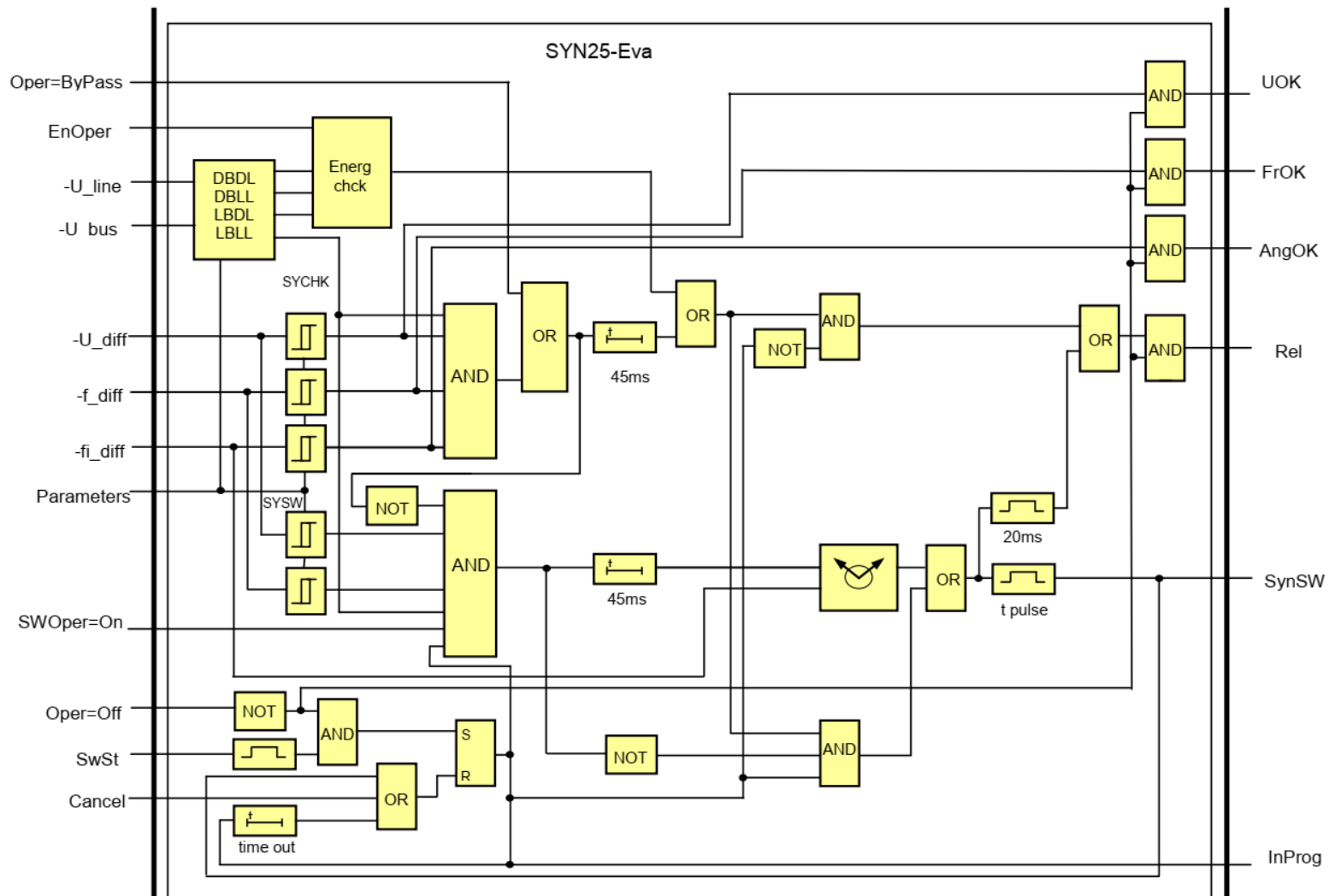
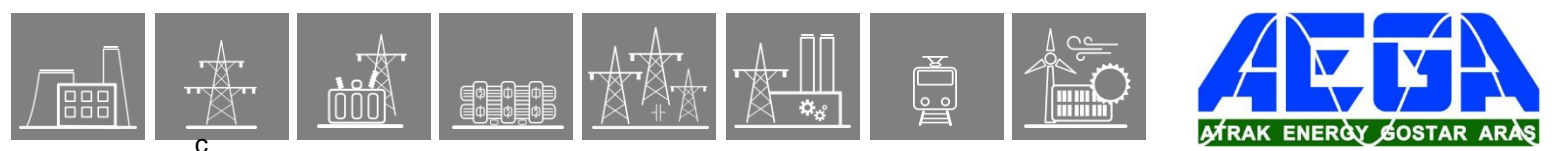

Figure 1-3 Structure of the evaluation software block



C

The started command can be canceled using the input signal SYN25_CancelA_GrO_/ SYN25_CancelM_GrO_ (Cancel Auto/Manual).

Enumerated parameters for automatic switching

Parameter name	Title	Selection range	Default
Operation mode for automatic switching			
SYN25_OperA_EPar_	Operation Auto	Off, On, ByPass	On
Enabling/disabling automatic switching			
SYN25_SwOperA_EPar_	SynSwitch Auto	Off,On	On
Energizing mode for automatic switching			
SYN25_EnOperA_EPar_	Energizing Auto	Off, DeadBus LiveLine, LiveBus DeadLine, Any energ case	DeadBus LiveLine

Table 1-8 The enumerated parameters of the evaluation software block for automatic switching

Enumerated parameters for manual switching

Parameter name	Title	Selection range	Default
Operation mode for manual switching			
SYN25_OperM_EPar_	Operation Man	Off, On, ByPass	On
Enabling/disabling manual switching			
SYN25_SwOperM_EPar_	SynSwitch Man	Off,On	On
Energizing mode for manual switching			
SYN25_EnOperM_EPar_	Energizing Man	Off,DeadBus LiveLine, LiveBus DeadLine, Any energ case	DeadBus LiveLine

Tables 1-9 The enumerated parameters of the evaluation software block for manual switching

Integer parameters

Parameter name	Title	Unit	Min	Max	Step	Default
Voltage limit for "live line" detection						
SYN25_LiveU_IPar_	U Live	%	60	110	1	70
Voltage limit for "dead line" detection						
SYN25_DealU_IPar_	U Dead	%	10	60	1	30

Table 1-10 Integer parameters of the evaluation software block

Parameter name	Title	Unit	Min	Max	Step	Default
Voltage difference for automatic synchro checking mode						
SYN25_ChkUdA_IPar_	Udiff SynChk Auto	%	5	30	1	10
Voltage difference for automatic synchro switching mode						
SYN25_SwUdA_IPar_	Udiff SynSW Auto	%	5	30	1	10
Phase difference for automatic switching						
SYN25_MaxPhDiffA_IPar_	MaxPhaseDiff Auto	deg	5	80	1	20

Table 1-11 Integer parameters of the evaluation software block for automatic switching

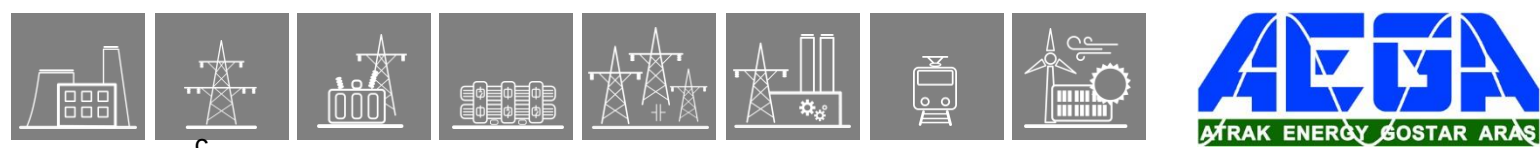

2.1.4.4. Technical summary

2.1.4.4.1. Technical data

Function	Effective range	Accuracy in the effective range
Rated Voltage U_n	100/200V, parameter setting	
Voltage effective range	10-110 % of U_n	$\pm 1\%$ of U_n
Frequency	47.5 – 52.5 Hz	± 10 mHz
Phase angle		$\pm 3^\circ$
Operate time	Setting value	± 3 ms
Reset time	<50 ms	
Reset ratio	0.95 U_n	

Table 1-16 Technical data of the synchro check / synchro switch function

2.1.4.4.2. Summary of the parameters

Enumerated parameters

Parameter name	Title	Selection range	Default
Selection of the processed voltage			
SYN25_VoltSel_EPar_	Voltage Select	L1-N,L2-N,L3-N,L1-L2,L2-L3,L3-L1	L1-N
Operation mode for automatic switching			
SYN25_OperA_EPar_	Operation Auto	Off, On, ByPass	On
Enabling/disabling automatic switching			
SYN25_SwOperA_EPar_	SynSW Auto	Off, On	On
Energizing mode for automatic switching			
SYN25_EnOperA_EPar_	Energizing Auto	Off, DeadBus LiveLine, LiveBus DeadLine, Any energ case	DeadBus LiveLine
Operation mode for manual switching			
SYN25_OperM_EPar_	Operation Man	Off, On, ByPass	On
Enabling/disabling manual switching			
SYN25_SwOperM_EPar_	SynSW Man	Off, On	On
Energizing mode for manual switching			
SYN25_EnOperM_EPar_	Energizing Man	Off,DeadBus LiveLine, LiveBus DeadLine, Any energ case	DeadBus LiveLine

Tables 1-17 The enumerated parameters of the synchro check / synchro switch function

Integer parameters

Parameter name	Title	Unit	Min	Max	Step	Default
Voltage limit for "live line" detection						
SYN25_LiveU_IPar_	U Live	%	60	110	1	70
Voltage limit for "dead line" detection						
SYN25_DeadU_IPar_	U Dead	%	10	60	1	30
Voltage difference for automatic synchro checking mode						
SYN25_ChkUdA_IPar_	Udiff SynCheck Auto	%	5	30	1	10
Voltage difference for automatic synchro switching mode						
SYN25_SwUdA_IPar_	Udiff SynSW Auto	%	5	30	1	10
Phase difference for automatic switching						
SYN25_MaxPhDiffA_IPar_	MaxPhaseDiff Auto	deg	5	80	1	20
Voltage difference for manual synchro checking mode						
SYN25_ChkUdM_IPar_	Udiff SynCheck Man	%	5	30	1	10
Voltage difference for manual synchro switching mode						
SYN25_SwUdM_IPar_	Udiff SynSW Man	%	5	30	1	10
Phase difference for manual switching						
SYN25_MaxPhDiffM_IPar_	MaxPhaseDiff Man	deg	5	80	1	20

Table 1-18 Integer parameters of the synchro check / synchro switch function

Floating point parameters

Parameter name	Title	Dim.	Min	Max	Default
Frequency difference for automatic synchro checking mode					
SYN25_ChkFrDA_FPar_	FrDiff SynCheck Auto	Hz	0.02	0.5	0.02
Frequency difference for automatic synchro switching mode					
SYN25_SwFrDA_FPar_	FrDiff SynSW Auto	Hz	0.10	1.00	0.2
Frequency difference for manual synchro checking mode					
SYN25_ChkFrDM_FPar_	FrDiff SynCheck Man	Hz	0.02	0.5	0.02
Frequency difference for manual synchro switching mode					
SYN25_SwFrDM_FPar_	FrDiff SynSW Man	Hz	0.10	1.00	0.2

Table 1-19 Floating point parameters of the synchro check / synchro switch function

Timer parameters

Parameter name	Title	Unit	Min	Max	Step	Default
Breaker operating time at closing						
SYN25_CBTTrav_TPar_	Breaker Time	msec	0	500	1	80
Impulse duration for close command						
SYN25_SwPu_TPar_	Close Pulse	msec	10	60000	1	1000
Maximum allowed switching time						
SYN25_MaxSw_TPar_	Max Switch Time	msec	100	60000	1	2000

Table 1-20 Timer parameters of the synchro check / synchro switch function

2.1.4.4.3. Summary of the generated output signals

The **binary output status signals** of the synchro check / synchro switch function are listed in Table 1-21.

Binary status signal	Title	Explanation
SYN25_RelA_Grl_	Release Auto	Releasing the close command initiated by the automatic reclosing function
SYN25_InProgA_Grl_	SynInProgr Auto	Switching procedure is in progress, initiated by the automatic reclosing function
SYN25_UOKA_Grl_	Udiff OK Auto	The voltage difference is appropriate for automatic closing command
SYN25_FrOKA_Grl_	FreqDiff OK Auto	The frequency difference is appropriate for automatic closing command, evaluated for synchro-check **
SYN25_AngOKA_Grl_	Angle OK Auto	The angle difference is appropriate for automatic closing command
SYN25_RelM_Grl_	Release Man	Releasing the close command, initiated by manual closing request
SYN25_InProgM_Grl_	SynInProgr Man	Switching procedure is in progress, initiated by the manual closing command
SYN25_UOKM_Grl_	Udiff OK Man	The voltage difference is appropriate for manual closing command
SYN25_FrOKM_Grl_	FreqDiff OK Man	The frequency difference is appropriate for manual closing command, evaluated for synchro-check **
SYN25_AngOKM_Grl_	Angle OK Man	The angle difference is appropriate for manual closing command

** *The frequency is evaluated using the weighted sum of the three phase voltages*

Table 1-21 *The binary output status signals of the synchro check / synchro switch function*

2.1.4.4.4. Summary of the input signals

Binary input status signals

The synchro check / synchro switch function has binary input status signals. **The conditions are defined by the user, applying the graphic equation editor.**

The **binary input status signals** of the synchro check / synchro switch function are listed in Table 1-22.

Binary status signal	Title	Explanation
SYN25_BusSel_GrO_	Bus select	If this signal is logic TRUE, then the voltage of Bus2 is selected for evaluation
SYN25_VTSBlk_GrO_	VTS Block	Blocking signal of the voltage transformer supervision function evaluating the line voltage
SYN25_Bus1VTSBlk_GrO_	VTS Bus1 Block	Blocking signal of the voltage transformer supervision function evaluating the Bus1 voltage
SYN25_Bus2VTSBlk_GrO_	VTS Bus2 Block	Blocking signal of the voltage transformer supervision function evaluating the Bus2 voltage
SYN25_SwStA_GrO_	SySwitch Auto	Switching request signal initiated by the automatic reclosing function
SYN25_CancelA_GrO_	Cancel Auto	Signal to interrupt (cancel) the automatic switching procedure
SYN25_Blk_GrO_	Block	Blocking signal of the function
SYN25_SwStM_GrO_	SySwitch Manual	Switching request signal initiated by manual closing
SYN25_CancelM_GrO_	Cancel Manual	Signal to interrupt (cancel) the manual switching procedure

Table 1-22 The binary input signal of the synchro check / synchro switch function

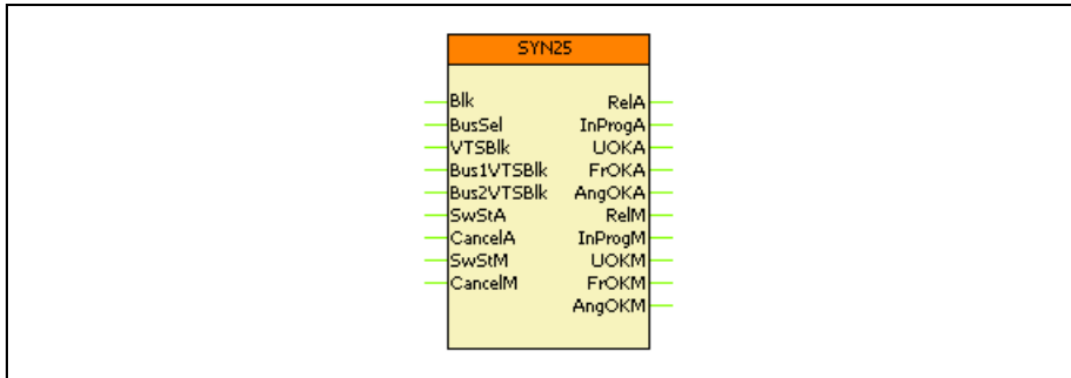

The symbol of the function block in the graphic editor

The names of the input and output signals are parts of the “Binary status signal” names listed in Table 1-21 and Table 1-22.

2.1.5.4. Structure of the definite time undervoltage protection algorithm

Fig.1-2 shows the structure of the definite time undervoltage protection (TUV27) algorithm.

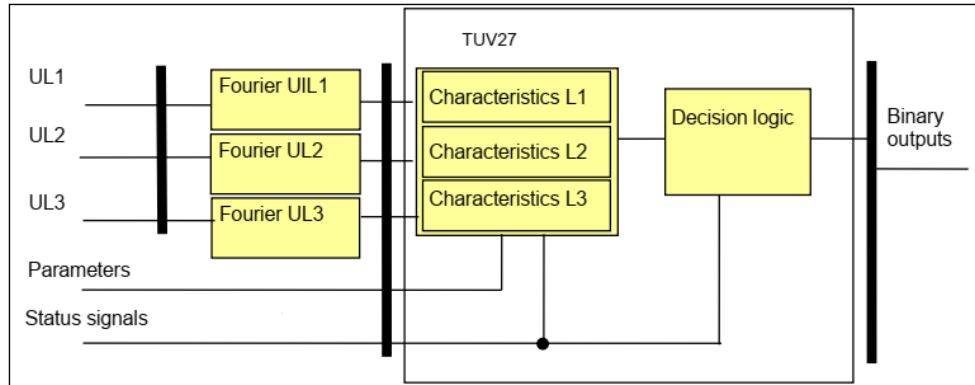

Figure 1-2 Structure of the definite time undervoltage protection algorithm

The **inputs** are

- the RMS values of the fundamental Fourier component of three phase (or phase-to-phase) voltages,
- parameters,
- status signals.

The **outputs** are

- the binary output status signals.

The **software modules** of the differential protection function:

Fourier calculations

These modules calculate the basic Fourier components of the phase voltages individually (not part of the TUV27 function). In medium voltage applications these are changed to phase-to-phase voltages.

Characteristics

This module calculates the required time delay based on the Fourier components of the phase (or phase-to-phase) voltages.

Decision logic

The decision logic module combines the status signals to generate the trip command of the function.

The following description explains the details of the individual components.

2.1.5.5. The Fourier calculation (Fourier)

These modules calculate the basic Fourier components of the phase voltages individually. They are not part of the TUV27 function; they belong to the preparatory phase.

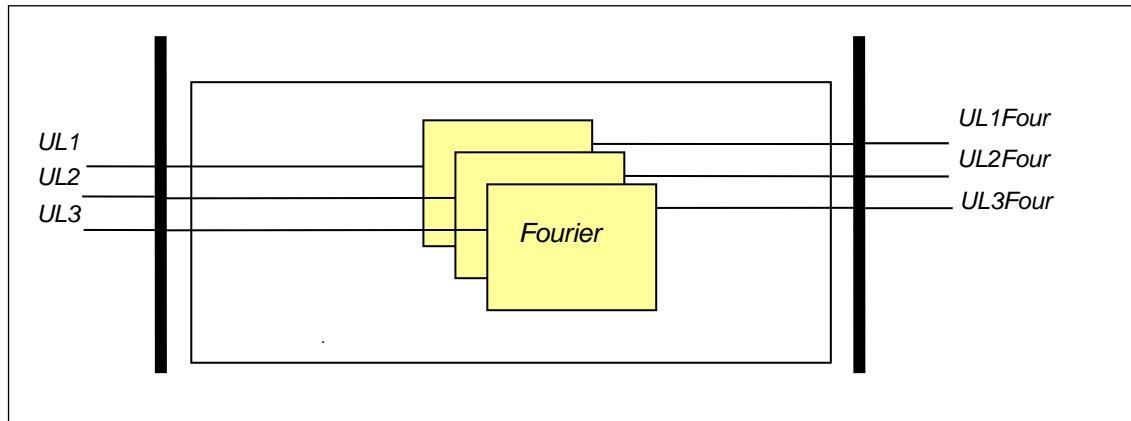
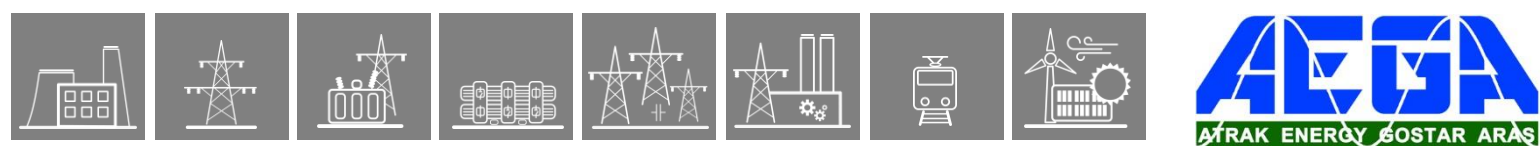

Figure 1-3 Schema of the Fourier calculation

The **inputs** are the sampled values of the three phase voltages (UL1, UL2, UL3)

The **outputs** are the basic Fourier components of the analyzed voltages (UL1Four, UL2Four, UL3Four).

The phase-to-phase voltages (if used) are also calculated here.



Boolean parameter

Parameter name	Title	Default	Explanation
TUV27_StOnly_BPar_	Start Signal Only	0	Selection if starting and trip signal or starting signal only is to be generated. Set 0 for trip command generation.

Table 1-4 The Boolean parameter of the undervoltage protection function

Timer parameter

Parameter name	Title	Unit	Min	Max	Step	Default
Time delay of the undervoltage protection function.						
TUV27_Delay_TPar_	Time Delay	ms	50	60000	1	100

Table 1-5 Timer parameter of the undervoltage protection function

The **binary output status signals** of the three-phase definite time undervoltage protection function are listed in *Table 1-6*.

Binary output signals	Signal title	Explanation
TUV27_StL1_Grl_	StL1	Starting of the function in phase L1*
TUV27_TrL1_Grl_	TrL1**	Trip command of the function in phase L1*
TUV27_StL2_Grl_	StL2	Starting of the function in phase L2*
TUV27_TrL2_Grl_	TrL2**	Trip command of the function in phase L2*
TUV27_StL3_Grl_	StL3	Starting of the function in phase L3*
TUV27_TrL3_Grl_	TrL3**	Trip command of the function in phase L3*

*In case of phase-to-phase voltages, these are changed to L12, L23, L31 respectively.

**The trip signals are not published for the phases individually

Table 1-6 The binary output status signals of the definite time undervoltage protection function

2.1.5.7. The decision logic (Decision logic)

The decision logic module combines the status signals, binary and enumerated parameters to generate the trip command of the function.

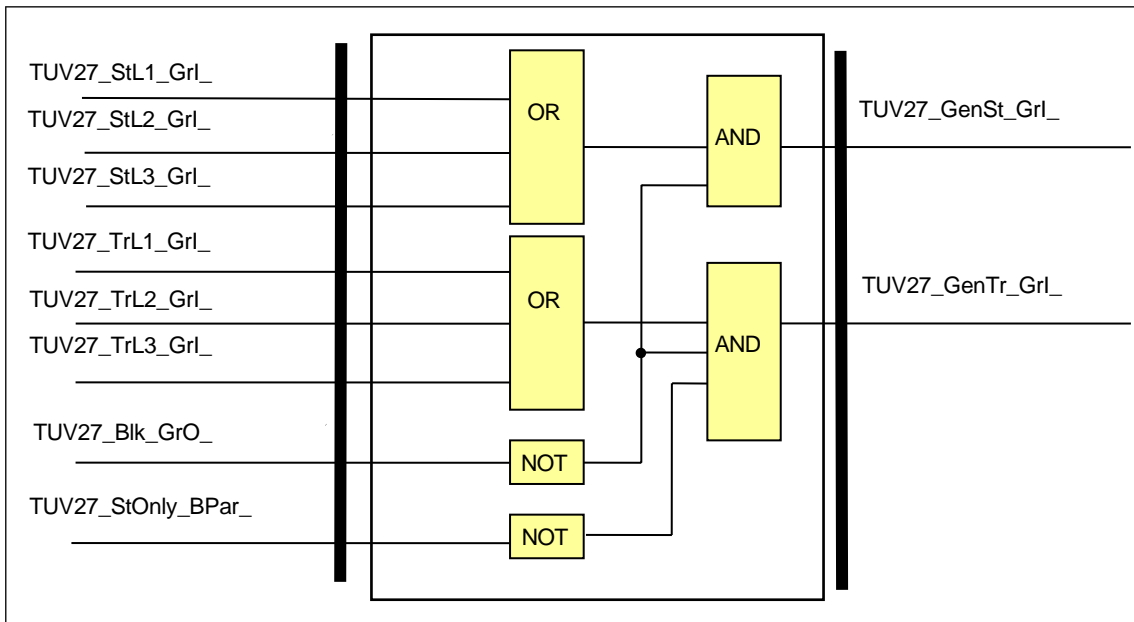

Figure 1-5 The logic scheme of the definite time undervoltage protection function

Binary input signals	Signal title	Explanation
TUV27_StL1_Grl_	StL1	Starting of the function in phase L1*
TUV27_TrL1_Grl_	TrL1**	Trip command of the function in phase L1*
TUV27_StL2_Grl_	StL2	Starting of the function in phase L2*
TUV27_TrL2_Grl_	TrL2**	Trip command of the function in phase L2*
TUV27_StL3_Grl_	StL3	Starting of the function in phase L3*
TUV27_TrL3_Grl_	TrL3**	Trip command of the function in phase L3*

*In case of phase-to-phase voltages, these are changed to L12, L23, L31 respectively.

**The trip signals are not published for the phases individually

Table 1-7 The binary input signals of the definite time undervoltage protection function

Boolean parameter

Parameter name	Title	Default
Enabling start signal only:		
TUV27_StOnly_BPar_	Start Signal Only	FALSE

Table 1-8 The Boolean parameter of the definite time undervoltage protection function

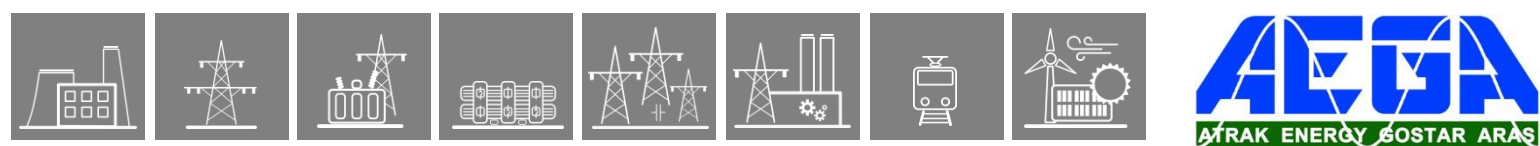

Binary status signals

The undervoltage protection function has a binary input signal, which serves the purpose of disabling the function. The conditions of disabling are defined by the user, applying the graphic equation editor.

Binary input status signal	Signal title	Explanation
TUV27_BlK_GrO_	Blk	Output status of a graphic equation defined by the user to disable the definite time undervoltage protection function.

Table 1-9 The binary input status signal of the definite time undervoltage protection function

Binary output status signal	Signal title	Explanation
TUV27_GenSt_Grl_	GenSt	General starting of the function
TUV27_GenTr_Grl_	GenTr	General trip command of the function

Table 1-10 The binary output status signals of the definite time undervoltage protection function

2.1.5.8. Technical summary

2.1.5.8.1. Technical data

Function	Value	Accuracy
Pick-up starting accuracy		< ± 0,5 %
Blocking voltage		< ± 1,5 %
Reset time		
U> → Un	50 ms	
U> → 0	40 ms	
Operate time accuracy		< ± 20 ms
Minimum operate time	50 ms	

Table 1-11 Technical data of the undervoltage protection function

2.1.5.8.1.1. The parameters

The parameters are summarized in Chapters 3.1.2.5 and 3.1.2.6

2.1.5.8.2. Binary output status signals

The **binary output status signals** of undervoltage protection function are listed in Table 1-12

Binary output status signal	Title	Explanation
TUV27_StL1_Grl_	StL1	Start in phase L1*
TUV27_StL2_Grl_	StL2	Start in phase L2*
TUV27_StL3_Grl_	StL3	Start in phase L3*
TUV27_GenSt_Grl_	GenSt	General start signal
TUV27_GenTr_Grl_	GenTr	General trip command

*In case of phase-to-phase voltages, these are changed to L12, L23, L31 respectively.

Table 1-12 The binary output status signals of the undervoltage protection function

2.1.5.8.3. Binary input status signals

Binary input signals

The undervoltage protection function has a binary input signal, which serves the purpose of disabling the function. **The conditions of disabling are defined by the user, applying the graphic equation editor.**

Binary status signal	Title	Explanation
TUV27_BlK_GrO_	Blk	Blocking of the undervoltage protection function

Table 1-13 The binary input signal of undervoltage protection function

2.1.5.8.4. The function block

The function block of undervoltage protection function is shown in Figure 1-6. This block shows all binary input and output status signals that are applicable in the graphic equation editor.

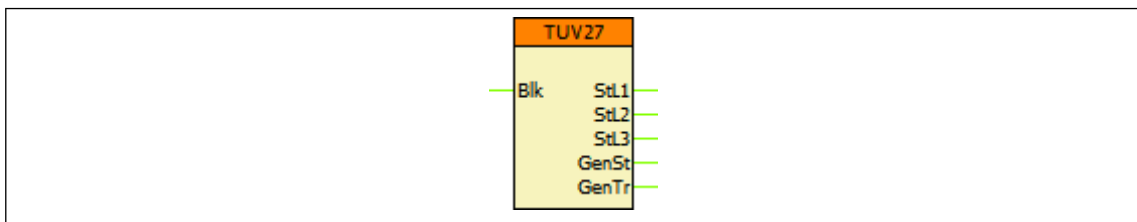
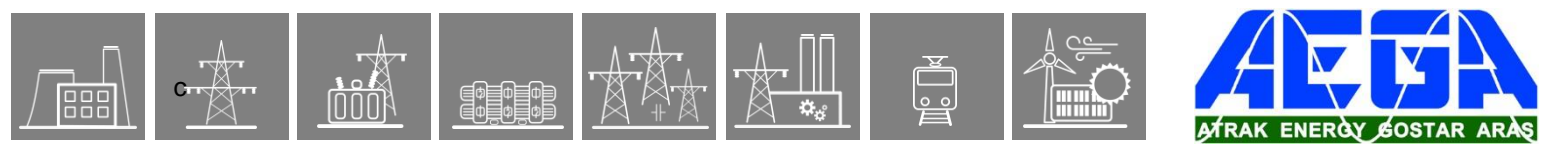

Figure 1-6 The function block of undervoltage protection function



2.1.6. Definite time third harmonic undervoltage protection function

2.1.6.1. Application

The definite time third harmonic undervoltage protection function can be applied to extend the stator earth fault protection system for a generator to 100% stator earth fault protection. Other protection functions, based on network frequency quantities, cannot detect the stator earth-faults near to the neutral point of the generator. This is due to the low value of the generated voltage in this range of the stator coil. These functions operate only if the earth-fault is relatively far from the neutral point.

The basic principle of extending the protected zone to the area near to the neutral point is the third harmonic voltage detection. It can be applied if a generator is connected to the unit transformer, the connection group of which isolates the generator from the network, regarding the zero sequence voltage and current.

Along the stator windings of the phases, due to the construction of a generator, a third harmonic voltage component is generated, which is of zero sequence nature. This zero sequence third harmonic voltage is divided between the distributed capacitances of the system (generator and transformer earth capacitance, etc.). As a consequence, in normal, symmetric operation a certain amount of third harmonic voltage can be measured in the neutral of the generator.

In case of a single phase-to-ground fault near to the neutral point of the generator, this voltage decreases, and the third harmonic undervoltage protection function detects the earth fault.

2.1.6.2. Mode of operation

The function generates start signal if the third harmonic voltage component is below the setting value.

The function generates a trip command only if the time delay has expired.

The function can be disabled via binary input if e.g. the basic harmonic voltage is low, indicating a not excited state of the generator. This needs the application also of a network frequency undervoltage function.

$$t(G) = t_{OP} \quad \text{when } G < G_s$$

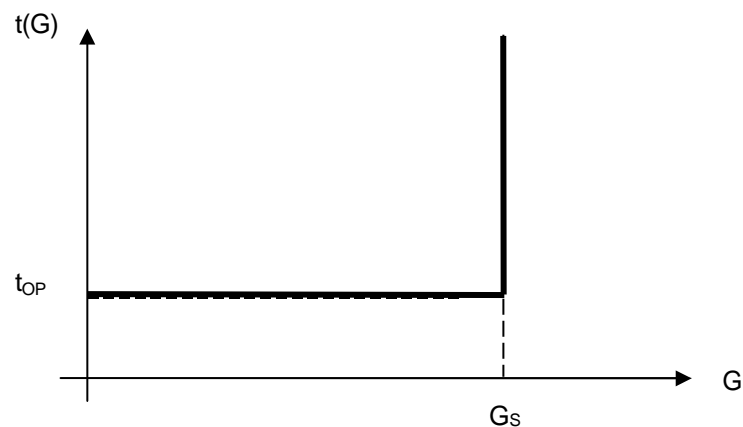

Figure 1-1 Third harmonic undervoltage independent time characteristic

where
 t_{OP} (seconds) theoretical operating time if $G < G_s$, according to parameter setting value,
 G measured value of the characteristic quantity, Fourier third harmonic of the neutral voltage,
 G_s setting value of the characteristic quantity.

2.1.6.3. Structure of the definite time third harmonic undervoltage protection algorithm

Fig.1-2 shows the structure of the definite time third harmonic undervoltage protection (HIZ64) algorithm.

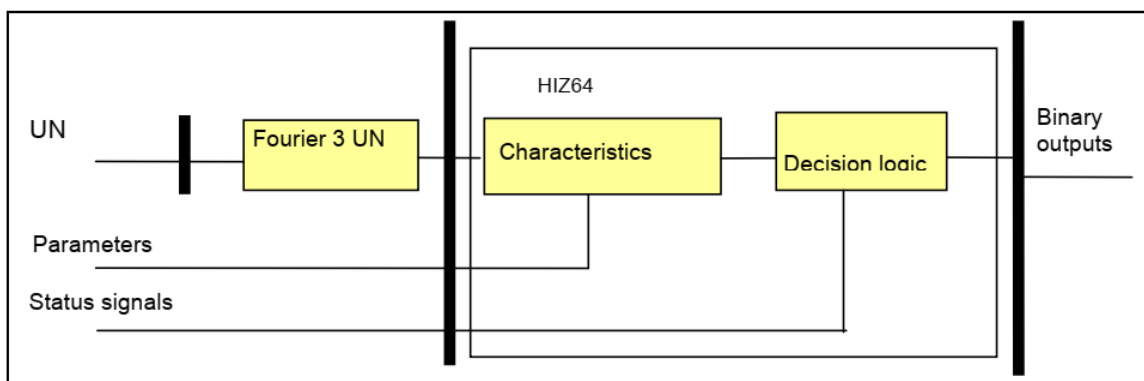

Figure 1-2 Structure of the definite time third harmonic undervoltage protection algorithm

The **inputs** are

- the RMS value of the third harmonic Fourier component of the generator neutral voltage,
- parameters,
- status signals.

The **outputs** are

- the binary output status signals.

The **software modules** of the differential protection function:

Fourier3 calculation

This module calculates the third harmonic Fourier component of the generator neutral point voltage (not part of the HIZ64 function).

Characteristics

This module calculates the required time delay based on the Fourier component of the generator neutral point voltage

Decision logic

The decision logic module combines the status signals to generate the trip command of the function.

The following description explains the details of the individual components.

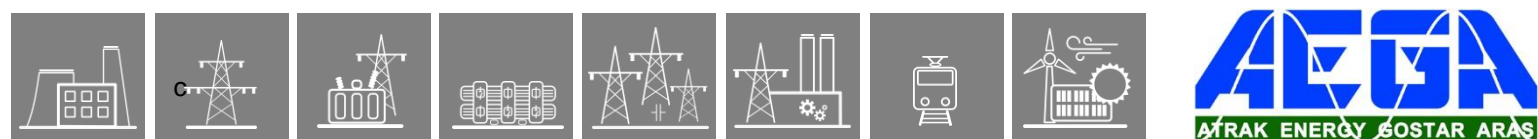

2.1.6.4. Parameters

Enumerated parameters

Parameter name	Title	Selection range	Default
Enabling or disabling the third harmonic undervoltage protection function			
HIZ64_Oper_EPar_	Operation	Off, On	Off

Table 1-1 The enumerated parameters of the third harmonic undervoltage protection function

Integer parameters

Parameter name	Title	Unit	Min	Max	Step	Default
Starting voltage level setting. If the measured voltage is below the setting value, the function generates a start signal.						
HIZ64_StVol_IPar_	UN3h start	%	2	10	1	5
Definite time delay setting						
HIZ64_Delay_IPar_	Delay	sec	1	3600	1	30

Table 1-2 Integer parameters of the third harmonic undervoltage protection function

Boolean parameters

The function does not have Boolean parameters.

Float parameters

The function does not have Float parameters.

Timer parameters

The function does not have timer parameters.

2.1.6.5. Technical summary

2.1.6.5.1. Technical data

Function	Value	Accuracy
Pick-up starting accuracy		< ± 0,5 %
Blocking voltage		< ± 1,5 %
Reset time	50 ms	
Operate time accuracy		< ± 20 ms
Minimum operate time	50 ms	

Table 1-3 Technical data of the third harmonic undervoltage protection function

2.1.6.5.2. The parameters

The parameters are summarized in Chapter 1.4.

2.1.6.5.3. Binary output status signals

The **binary output status signals** of third harmonic undervoltage protection function are listed in Table 1-4.

Binary status signal	Title	Explanation
HIZ64_Start_Grl_	Start	Start signal
HIZ64_Trip_Grl_	Trip	Trip command

Table 1-4 The binary output status signals of the third harmonic undervoltage protection function

2.1.6.5.4. The binary input status signals

Binary input signals

The third harmonic undervoltage protection function has a binary input signal, which serves the purpose of disabling the function. **The conditions of disabling are defined by the user, applying the graphic equation editor.**

Binary status signal	Title	Explanation
HIZ64_Blkc_GrO_	Block	Blocking of the third harmonic undervoltage protection function

Table 1-5 The binary input signal of third harmonic undervoltage protection function

2.1.6.5.5. The function block

The function block of third harmonic undervoltage protection function is shown in Figure 1-5. This block shows all binary input and output status signals that are applicable in the graphic equation editor.

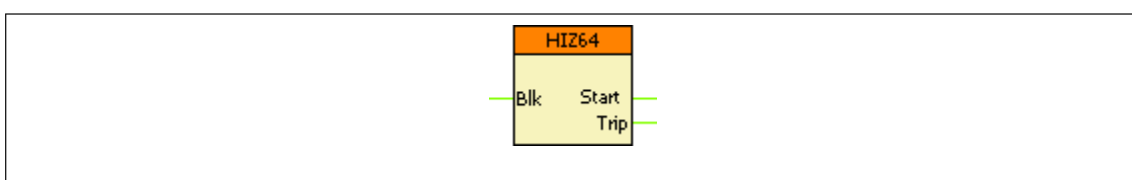

Figure 1-5 The function block of third harmonic undervoltage protection function

2.1.7. Directional over-power protection function

2.1.7.1. Application

The directional over-power protection function can be applied to protect any elements of the electric power system mainly generators if the active and/or reactive power has to be limited.

2.1.7.2. Mode of operation

The inputs of the function are the Fourier basic harmonic components of the three phase currents and those of the three phase voltages.

Based on the measured voltages and currents, the block calculates the three-phase active and reactive power (point S in Figure 1-1) and compares the P-Q coordinates with the defined characteristics on the power plane. The characteristic is defined as a line laying on the point S_s and perpendicular to the direction of S_s . The S_s point is defined by the "Start power" magnitude and the "Direction angle". The over-power function operates if the angle of the S- S_s vector related to the directional line is below 90 degrees and above -90 degrees.

At operation, the "Start power" value is decreased by a hysteresis value.

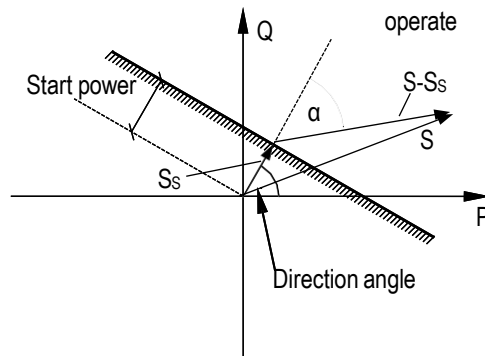

Figure 1-1 The directional over-power decision

2.1.7.3. Structure of the directional over-power protection algorithm

Figure 1-2 shows the structure of the directional over-power protection (DOP32) algorithm.

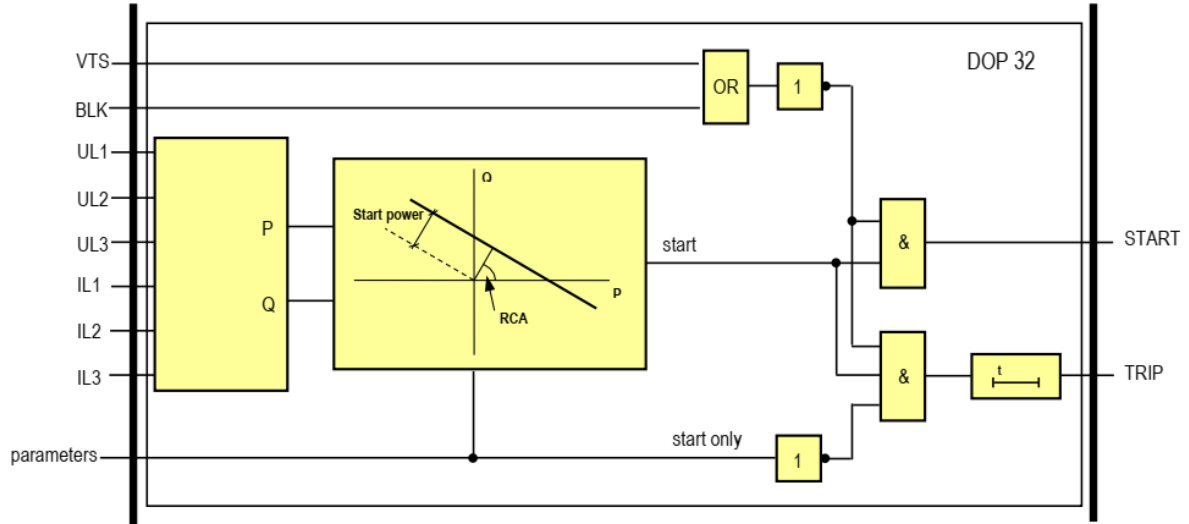

Figure 1-2 Structure of the directional over-power protection algorithm

The **inputs** are

- the RMS value of the fundamental Fourier component of the three phase currents (IL1, IL2, IL3),
- the RMS value of the fundamental Fourier component of the three phase voltages (UL1, UL2, UL3),
- parameters, status signals

The function can be enabled or disabled (Blk). The status signal of the VTS (voltage transformer supervision) function can also disable the directional operation.

The **outputs** are

- the binary output status signals.

The **software modules** of the directional over-power protection function are described in the following chapter.

2.1.7.3.1. P-Q calculation

Based on the RMS values of the fundamental Fourier component of the three phase currents and of the three phase voltages, this module calculates the three-phase active and reactive power values.

The **input signals** are the RMS values of the fundamental Fourier components of the three phase currents and three phase voltages.

The **internal output signals** are the calculated three-phase active and reactive power values.

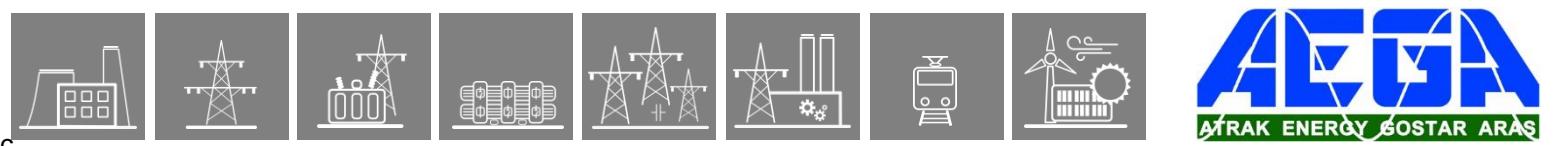

2.1.7.3.2. Directional decision

This module decides if, on the power plane, the calculated complex power is farther from the origin than the corresponding point of the characteristic line. The operation of this function is explained in Figure 1-1.

The **internal input signals** are the calculated active and reactive power values.

The **internal output signal** is the start signal of the function.

2.1.7.3.3. The decision logic

This part of the function block combines status signals to make a decision to start. Additionally to the directional decision, for the operation, the function must not be blocked by the general “Block” signal, and may not be blocked by the signal “Block for VTS” of the voltage transformer supervision function.

If the parameter setting requires also a trip signal (Start Signal Only = 0), then the measurement of the definite time delay is started. The expiry of this timer results in a trip command.

2.1.7.4. Directional over-power protection function overview

The function block of the directional over-power protection function is shown on the figure below. This block shows all binary input and output status signals that are applicable in the graphic equation editor.

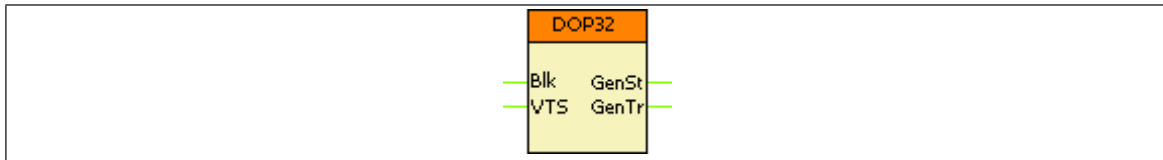

Figure 2-1 The function block of the directional over-power protection function

2.1.7.5. Settings

2.1.7.5.1. Parameters

Table 2-1 Parameters of the over-power protection function

TITLE	DIM	RANGE	STEP	DEFAULT	EXPLANATION
Operation	-	Off, On	-	Off	Enabling the function
Start Signal Only	-	FALSE, TRUE	-	FALSE	Selection: start signal only or both start signal and trip command
Direction Angle	deg	-179 – 180	1	0	Angle which belongs to Start power
Start Power	%	1.0 – 200.0	0.1	10.0	Start power of the function
Time Delay	msec	200 – 60000	1	200	Definite time delay of the trip command

2.1.7.6. Function I/O

This section describes briefly the analogue and digital inputs and outputs of the function block.

2.1.7.6.1. Binary output signals (graphed input statuses)

The binary output status signals of the over-power protection function can be found in the following table. **Parts** written in **bold** are seen on the function block in the logic editor.

Table 2-2 The binary output status signals of the directional over-power protection function

BINARY STATUS SIGNAL	TITLE	EXPLANATION
DOP32_ GenSt _GrI_	General Start	General start signal of the function
DOP32_ GenTr _GrI_	General Trip	Trip command of the function



2.1.7.6.2. Binary input signals (graphed output statuses)

The directional over-power protection function has binary input status signals. **The conditions are defined by the user, applying the graphic equation editor.**

Table 2-3 The binary input status signals of the directional over-power protection function

BINARY STATUS SIGNAL	TITLE	EXPLANATION
DOP32_VTS_GrO_	Block from VTS	Blocking signal from the voltage transformer supervision function
DOP32_Blk_GrO_	Block	General blocking signal

2.1.7.6.3. On-line data

Visible values on the on-line data page:

Table 2-4 On-line data of the directional over-power protection function

SIGNAL TITLE	DIMENSION	EXPLANATION
General Start	-	General start of the function
General Trip	-	General trip command of the function

2.1.7.6.4. Events

The following events are generated in the event list, as well as sent to SCADA according to the configuration.

Table 2-5 Events of the directional over-power protection function

EVENT	VALUE	EXPLANATION
General Start	off, on	General start of the function
General Trip	off, on	General trip command of the function

2.1.8.3. Structure of the directional under-power protection algorithm

Figure 1-2 shows the structure of the directional under-power protection (DUP32) algorithm.

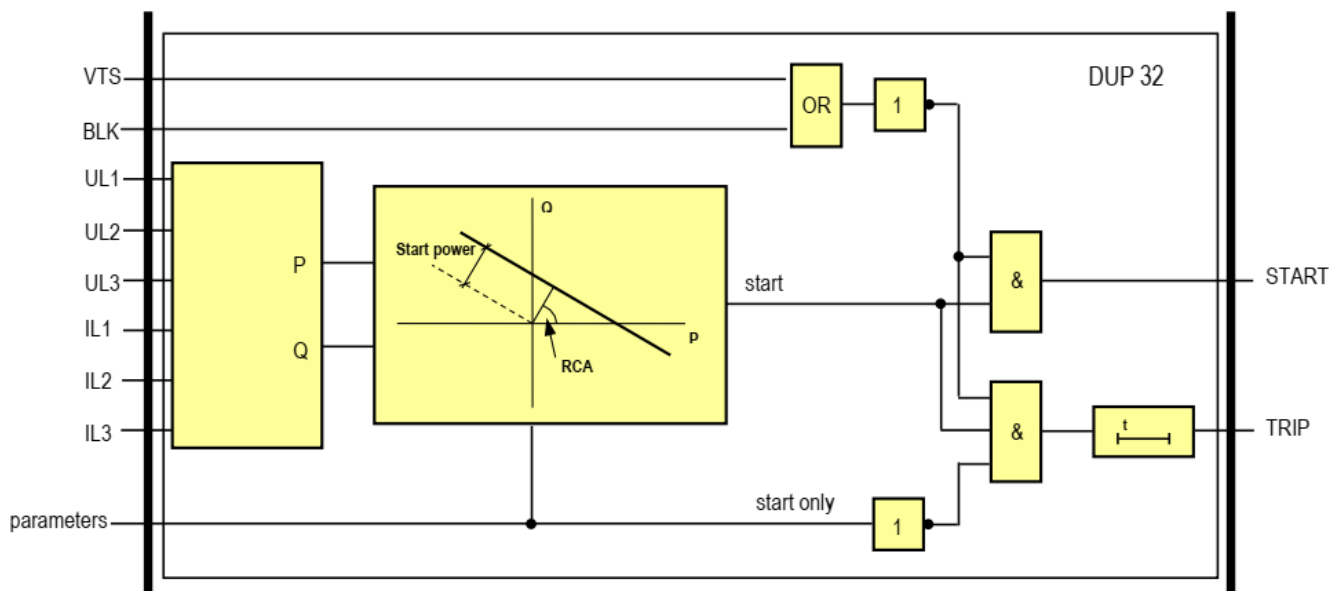

Figure 1-2 Structure of the directional under-power protection algorithm

The **inputs** are

- the RMS value of the fundamental Fourier component of the three phase currents (IL1, IL2, IL3),
- the RMS value of the fundamental Fourier component of the three phase voltages (UL1, UL2, UL3),
- parameters,
- status signals.

The function can be enabled or disabled (BLK input signal). The status signal of the VTS (voltage transformer supervision) function can also disable the directional operation.

The **outputs** are

- the binary output status signals.

The **software modules** of the directional under-power protection function are described in the following chapters.

2.1.8.3.1. P-Q calculation

Based on the RMS values of the fundamental Fourier component of the three phase currents and of the three phase voltages, this module calculates the three-phase active and reactive power values.

The **input signals** are the RMS values of the fundamental Fourier components of the three phase currents and three phase voltages.

The **internal output signals** are the calculated three-phase active and reactive power values.

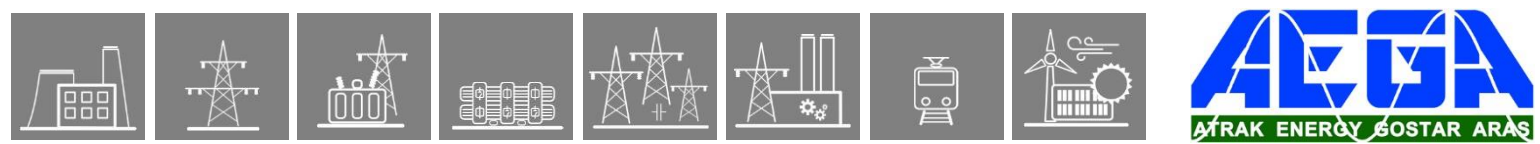

2.1.8.3.2. Directional decision

This module decides if, on the power plane, the calculated complex power is closer to the origin than the corresponding point of the characteristic line, i.e. if the point S is on the “Operate” side of the P-Q plane. The operation of this function is explained in Figure 1-1.

The **internal input signals** are the calculated active and reactive power values.

The **internal output signal** is the start signal of the function.

2.1.8.3.3. The decision logic

This part of the function block combines status signals to make a decision to start. Additionally to the directional decision, for the operation, the function must not be blocked by the general “Block” signal, and may not be blocked by the signal “Block for VTS” of the voltage transformer supervision function.

If the parameter setting requires also a trip signal (Start Signal Only = 0), then the measurement of the definite time delay is started. The expiry of this timer results in a trip command.

2.1.8.4. Directional under-power protection function overview

The function block of the directional under-power protection function is shown on the figure below. This block shows all binary input and output status signals that are applicable in the graphic equation editor.

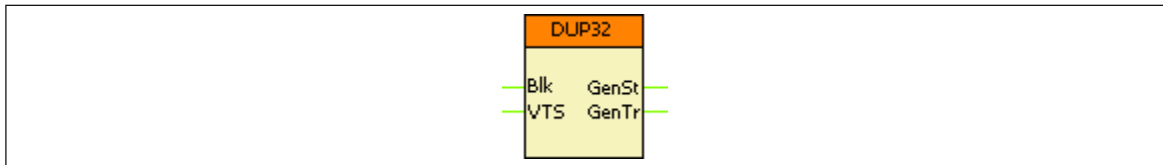

Figure 2-1 The function block of the directional under-power protection function

2.1.8.4.1. Settings

2.1.8.4.1.1. Parameters

Table 2-1 Parameters of the under-power protection function

TITLE	DIM	RANGE	STEP	DEFAULT	EXPLANATION
Operation	-	Off, On	-	Off	Enabling the function
Start Signal Only	-	FALSE, TRUE	-	FALSE	Selection: start signal only or both start signal and trip command
Direction Angle	deg	-179 – 180	1	0	Angle which belongs to Start power
Start Power	%	1.0 – 200.0	0.1	10.0	Start power of the function
Time Delay	msec	200 – 60000	1	200	Definite time delay of the trip command

2.1.8.4.2. Function I/O

This section describes briefly the analogue and digital inputs and outputs of the function block.

2.1.8.4.2.1. Binary output signals (graphed input statuses)

The binary output status signals of the under-power protection function can be found in the following table. **Parts** written in **bold** are seen on the function block in the logic editor.

Table 2-2 The binary output status signals of the directional under-power protection function

BINARY STATUS SIGNAL	TITLE	EXPLANATION
DUP32_ GenSt _GrI_	General Start	General start signal of the function
DUP32_ GenTr _GrI_	General Trip	Trip command of the function

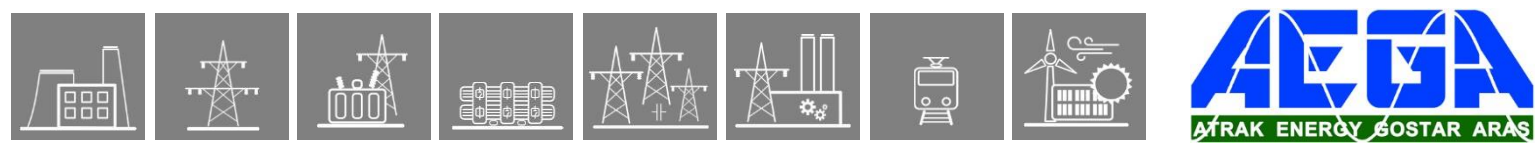

2.1.8.4.2.2. Binary input signals (graphed output statuses)

The directional under-power protection function has binary input status signals. **The conditions are defined by the user, applying the graphic equation editor.**

Table 2-3 The binary input status signals of the directional under-power protection function

BINARY STATUS SIGNAL	TITLE	EXPLANATION
DUP32_VTS_GrO_	Block from VTS	Blocking signal from the voltage transformer supervision function
DUP32_Blk_GrO_	Block	General blocking signal

2.1.8.4.2.3. On-line data

Visible values on the on-line data page:

Table 2-4 On-line data of the directional under-power protection function

SIGNAL TITLE	DIMENSION	EXPLANATION
General Start	-	General start of the function
General Trip	-	General trip command of the function

2.1.8.4.2.4. Events

The following events are generated in the event list, as well as sent to SCADA according to the configuration.

Table 2-5 Events of the directional under-power protection function

EVENT	VALUE	EXPLANATION
General Start	off, on	General start of the function
General Trip	off, on	General trip command of the function

2.1.8.4.3. Technical data

Table 2-6 Technical data of the directional under-power protection function

FUNCTION	VALUE	ACCURACY
P,Q measurement	$I > 10\% I_n^*$	< 5%
P,Q meas with CT1500	$I > 5\% I_n^*$	< 5%
Direction angle	$-179 - + 180^\circ^*$	< 5%
	* = Angle btw. U&I: $-70^\circ - +70^\circ$	
Reset ratio	1.05	
Reset time	< 100 ms	
Operating time	< 125 ms	
Time delay	0.2 – 60 s	1% or ± 25 ms

2.1.8.4.3.1. Notes for testing

Normally in the EuroProt+ devices the trip contacts are assigned to the Trip Logic function block, and not to the protection function blocks. Because of this, the testing personnel must make sure that the Trip Logic is switched on ('Operation' parameter is set to other than 'Off') before starting the testing, otherwise there will be no physical trip on the relay.

The function is based on the power measurement of the Line Measurement function block. This must be taken into consideration when the device has a separate CT for measurements, because with it, the under-power protection function will use that CT as well.

2.1.9. GGIORTD temperature measurement function

2.1.9.1. Application of the GGIORTD temperature measurement

If the factory configuration includes an RTD temperature input hardware module, the temperature input function block is automatically configured among the software function blocks. Separate temperature input function blocks are assigned to each temperature input hardware module.

The RTD+1100 temperature input hardware module is equipped with four special input channels, the RTD+ 0200 has a single channel only. (See **EuroProt+ hardware description document**.) To each channel, a temperature sensor (thermocouple) can be connected. The temperature is measured as the resistance value of the sensor, which depends on the temperature.

The sensors can be connected by wiring methods, shown in Figure 1–1, Figure 1–2 and Figure 1–3. The connection mode is indicated also by parameter setting in the RTD temperature input function block. See document „**EuroProt RTD temperature input function block description**”.

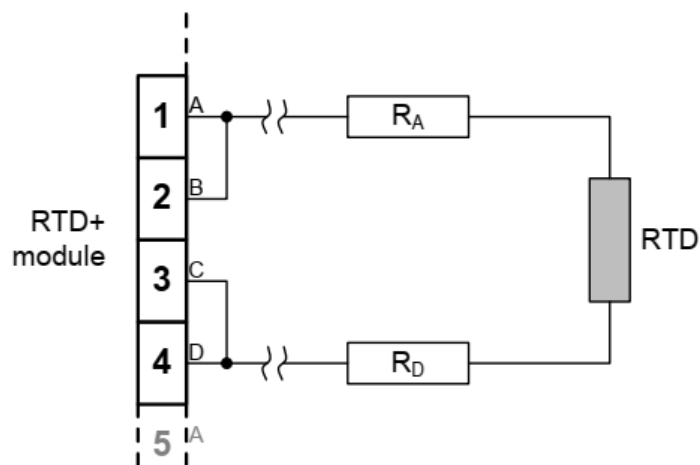

Figure 1–1 2-wire RTD wiring

When 2-wire connection is applied then R_A and R_D values must be subtracted from the calculated resistance. This is done based on the parameter value shown in Table 1.

Parameter name	Title	Dim.	Min	Max	Step	Default
Deadband value for the active power						
GGIORTD_OhmBias_FPar_	Ohm bias (2 wire)	Ohm	0.00	100.00	0.01	0.00

Table 1 The parameter for cable resistance correction

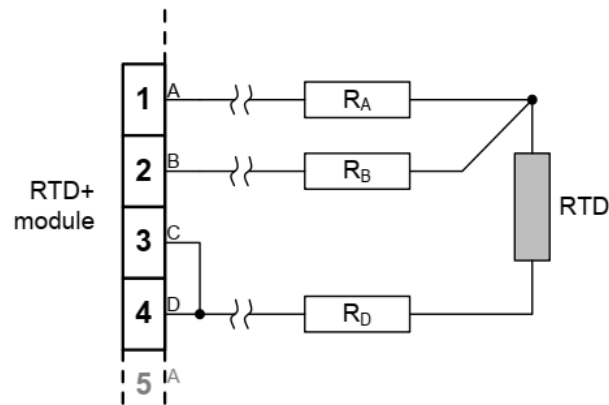

Figure 1-2 3-wire RTD wiring

When 3-wire connection is applied, it is supposed that $R_A=R_D$. Related to this correction, no parameter value is needed.

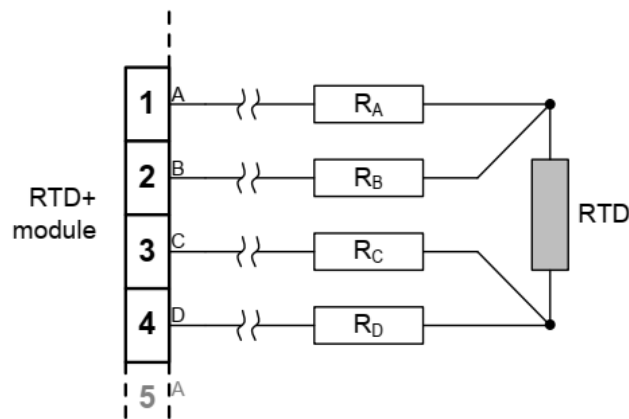

Figure 1-3 4-wire RTD wiring

The channels of the module are independent of each other. To each channel a dedicated measuring module is assigned. These measuring modules are described in this document.

2.1.9.2. The measurement

The RTD hardware module is prepared to connect the following types of sensors:

- Pt100/Ni100
- Ni120/Ni120US
- Pt250/Ni250
- Pt1000/Ni1000
- Cu10
- Service-Ohm (60 Ω ... 1.6 kΩ)

The applied type of sensors define the conversion mode from measured resistance to temperature. These are selected by a parameter of this measuring module. See Table 2.

Parameter name	Title	Selection range	Default
Selection of the measurement mode			
GGIORTD_RTDTtype_EPar_	Resistor type	PT100,PT250,PT1000, Ni100,Ni120,Ni250, Ni1000,Ni120US,Cu10 ,Service-Ohm	PT100

Table 2 The enumerated parameter for resistor type selection

C

The measured temperature value in each channel can be

- monitored for limit value violation,
- reported to the SCADA system,
- displayed, or
- applied in other function blocks.

2.1.9.3. Monitoring the measured temperature value

The GGIORTD generates binary signals, if

- the measured temperature is out of the range, defined by “MinValue” and “MaxValue” parameters. (The output signal is “Out of Range”.);
- the measured temperature is below the “LowAlarm” parameter value. (The output signal is “LowAlarm”);
- the measured temperature is above the “HighAlarm” parameter value. (The output signal is “HighAlarm”).

The parameters needed for monitoring the measured temperature values are summarized in Table 3.

Parameter name	Title	Dim.	Min	Max	Step	Default
Minimum value for the temperature monitoring						
GGIORTD_MinValue_FPar_	MinValue	C	-50	150	1	50
Maximum value for the temperature monitoring						
GGIORTD_MaxValue_FPar_	MaxValue	C	-50	150	1	150
Low value for the temperature alarm signal						
GGIORTD_LowAlarm_FPar_	LowAlarm	C	-50	150	1	50
High value for the temperature alarm signal						
GGIORTD_HighAlarm_FPar_	HighAlarm	C	-50	150	1	100

Table 3 Parameters for monitoring the measured temperatures

2.1.9.4. Reporting the measured values and the changes

For reporting, additional information is needed, which is defined in parameter setting. The reporting can be triggered by changes in the measured value or the reporting starts periodically. The changes can be monitored using two methods, one of them is to be selected by the parameter “ReportDB”, shown in Table 4. All reports can be disabled if the reporting mode is set to “Off”.

Enumerated parameters

Parameter name	Title	Selection range	Default
Selection of the reporting mode for active power measurement			
GGIORTD_RepMode_EPar_	ReportDB	Off, Amplitude, Integrated	Off

Table 4 The enumerated parameter for reporting the temperature changes

The selection of the reporting mode items is explained here and in Figure 1-4 and in Figure 1-5.

C

2.1.9.4.1. “Amplitude” mode of reporting

If the “Amplitude” mode is selected for reporting, a report is generated if the measured value leaves the deadband around the previously reported value. As an example, Figure 1-4 shows that the temperature becomes higher than the value reported in “report1” PLUS the “Deadband value”, this results “report2”, etc.

Floating point parameters

Parameter name	Title	Dim.	Min	Max	Step	Default
Deadband value for the temperature reporting						
GGIORTD_DeadB_FPar__	Deadband value	C	1	50	1	1

Table 5 The floating point parameter for reporting the temperature changes

Amplitude

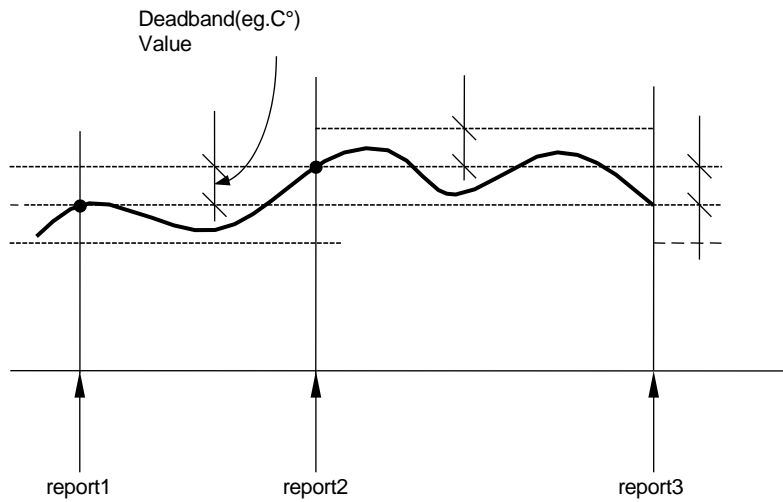

Figure 1-4 Reporting if “Amplitude” mode is selected

C

2.1.9.4.2. “Integrated” mode of reporting

If the “Integrated” mode is selected for reporting, a report is generated if the time integral of the measured value since the last report in the positive or negative direction becomes larger, than the (deadband*1sec) area. As an example, Figure 1-5 shows that the integral of the temperature in time becomes higher than the Deadband value multiplied by 1sec, this results “report2”, etc.

Integrated

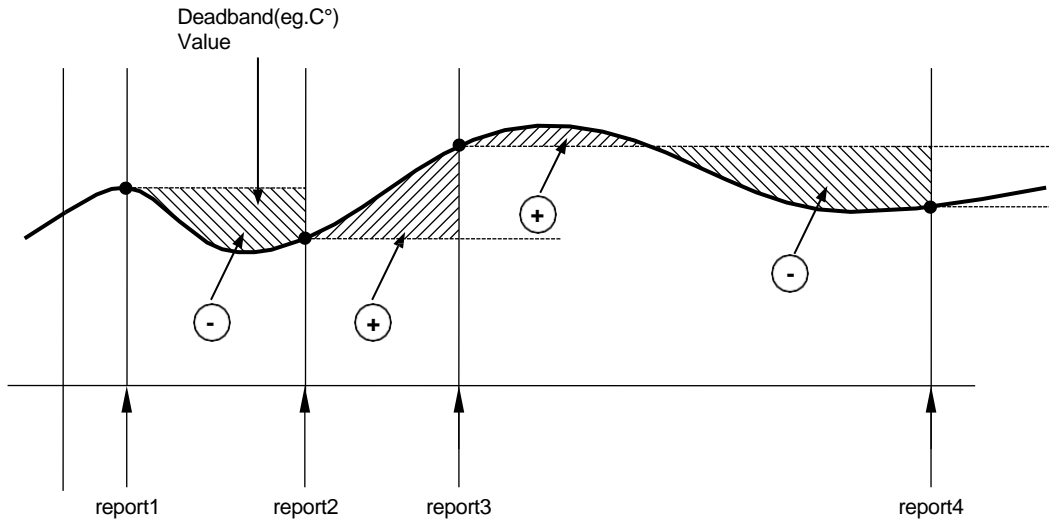
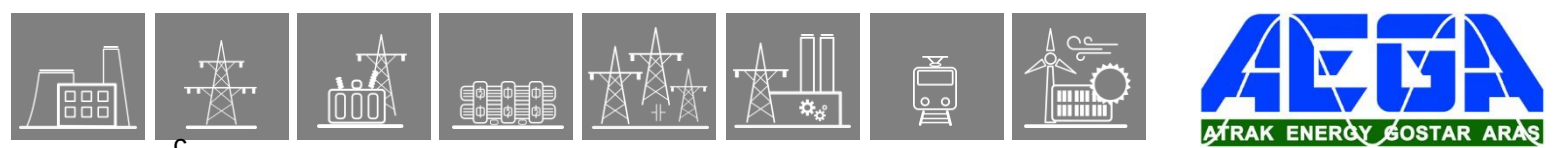

Figure 1-5 Reporting if “Integrated” mode is selected



C

2.1.9.4.3. Periodic reporting

Periodic reporting is generated independently of the changes of the measured values when the defined time period elapses. The required parameter setting is shown in Table 6.

Integer parameters

Parameter name	Title	Unit	Min	Max	Step	Default
Reporting time period for the temperature value						
GGIORTD_IntPer_IPar_	Periodic Rep	sec	0	3600	1	0

Table 6 The integer parameter for periodic reporting the temperature

If the reporting time period is set to 0, then no periodic reporting is performed for the temperature.

2.1.9.5. Displaying the measured value

The function block displays the measured temperature value for each channel. The dimension is Celsius degree (°C).

2.1.9.6. Technical summary

2.1.9.6.1. Binary output signal

The binary output status signals of the temperature measurement function block are listed in Table 7

Binary output signals	Signal title	Explanation
GGIORTD_LowAlm_Grl_	LowAlarm	This signal gets logic 1 if the measured temperature is below the value defined by parameter “LowAlarm”
GGIORTD_HighAlm_Grl_	HighAlarm	This signal gets logic 1 if the measured temperature is above the value defined by parameter “HighAlarm”
GGIORTD_OutofRange_Grl_	Out of Range	This signal gets logic 1 if the measured temperature gets out of the range defined by parameters “MinValue” and “MaxValue”

Table 7 The binary output status signals of the temperature measurement

2.1.9.6.2. Binary input signal

The differential protection function has no binary input signals.

2.1.9.6.3. The function block

The function blocks of the temperature measurement function is shown on Figure 1-6. This block shows all binary output status signals, which are applicable in the graphic logic editor.

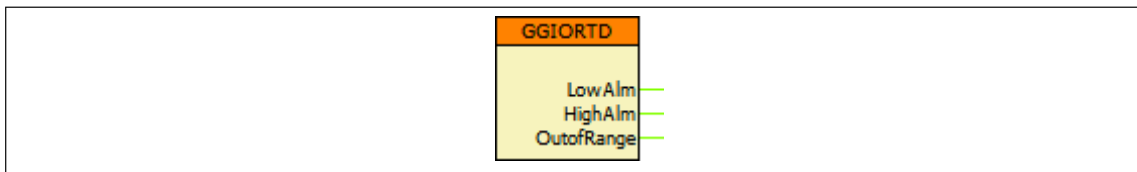

Figure 1-6 The function block of the temperature measurement function

2.1.10. Loss of excitation protection (Version 40Q)

2.1.10.1. Field of application

When a synchronous generator connected parallel to the network loses the excitation, or the field decreases below the permitted limit then the missing magnetizing reactive power is taken from the other generators and from the network. This state can be caused by the failure of the excitation system, the error of the voltage controller, or when the system is switched over from automatic excitation to manual control then the manual system is set to inappropriate state. The consequences are:

- The generator stator current increases to dangerous level,
- The reactive power is supplied by the other operating generators of the power station, and they get unwanted trip command, due to the increased current,
- The generator gets out of the synchronous state and
 - It operates after that as an asynchronous machine, causing power swing and additional heat generation,
 - Or the speed of the generator increases above the tolerable speed.

To prevent the dangers listed above, the generator without excitation should be tripped. This is the function of the loss of excitation protection.

The special characteristic of the loss of excitation function on the complex impedance plane is shown in Figure 1-1. The shape of the relay detecting the negative reactance is a circle, centered to the $-jX$ reactance axis.

The usual setting values of the characteristic parameters are the following:

The parameter value of the reactance located closest to the origin is the half of the transient

reactance $X_1 = \frac{1}{2} X'_d$, and that of the farthest is the doubled value of the synchronous

reactance X_d , which is $X_2 = 2X_d$. If in normal operation the generator is intended to take

reactive power from the network then $X_2 = X_d$.

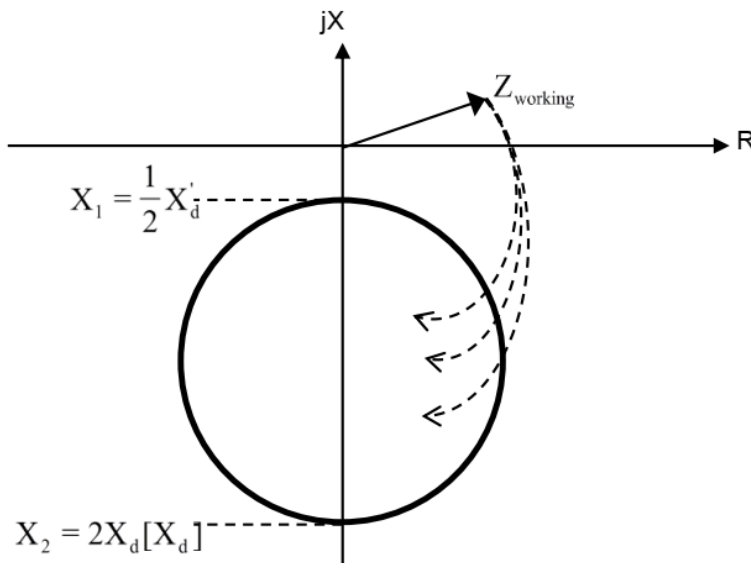

Figure 1-1 Characteristics of the loss of excitation function

where

X'_d is the transient reactance of the generator,

X_d is the synchronous reactance of the generator.



This characteristic does not reach the origin, to prevent unwanted operation during the synchronizing process if in capacitive reactive power state or in case of close-in fault state.

In case of loss of excitation, when the generator is still running with synchronous state, the impedance of the generator seen from the network is an inductive reactance (+X), but considering the positive direction according to the generated power, it is a capacitive reactance (-X). The measured impedance, depending on the generated active and reactive power, moves inside the circle characteristic line along the dotted line of Figure 1-1. Accordingly this characteristic can detect the loss of excitation state.

The configured protection function has two stages. The characteristics and the time delay of the individual stages can be set independently of each other. As usual, the first stage sends command to the turbine fast closing valve. After closing this valve, the generator is tripped by the reverse power protection function. This procedure allows time to switch over the auxiliary power system to reserve mode without loss of supply. The second stage usually generates the command to full trip of the machine, if the circuit breaker could not trip yet. The time delay of the first stage is usually 1 s, the setting value for the second stage is 4...5 s, but it should be below the overload protection setting value of the other generators connected to the same busbar.

If the generator operates further in asynchronous mode, then the measured impedance enters and leaves the characteristic circle several times. Due to this operation, it can happen that the first stage does not reach time-out, and the protection function does not generate a trip command. To prevent this asynchronous mode of operation there is another protection function to be applied (pole slipping protection function: PSLIP78).

The setting values of the reactance parameters are calculated as percentage of the reactance, which is the ratio of the rated phase voltage of the voltage transformer and the rated current of the current transformer. (U_{Phase_n} / I_n %). NOTE: this is not the percentage drop value given as a parameter of the generator. The base sensitivity in % is related to the rated current value of the current transformer.

The function calculates the three impedances of the line-to-line loops. The output status signal is generated as OR relationship of three decisions.

Timer parameters

Parameter name	Title	Unit	Min	Max	Step	Default
Time delay for stage 1						
UEX_40Q_Del1_TPar_	Stage1 Delay	msec	50	60000	1	100
Time delay for stage 2						
UEX_40Q_Del2_TPar_	Stage2 Delay	msec	50	60000	1	100

Table 1-6 The timer parameters of the loss of excitation function

2.1.10.2.3. Summary of the generated output signals

The **binary output status signals** of the circular impedance protection function:

Binary status signal	Title	Explanation
UEX40_GenSt1_Grl_	Stage1 Start	General start signal of the first stage
UEX40_GenTr1_Grl_	Stage1 Trip	General trip signal of the first stage
UEX40_GenSt2_Grl_	Stage2 Start	General start signal of the second stage
UEX40_GenTr2_Grl_	Stage2 Trip	General trip signal of the second stage

Table 1-7 The binary output status signals of the loss of excitation function

2.1.10.2.4. Summary of the input signals

The loss of excitation function has binary input status signals. **The conditions are defined by the user, applying the graphic equation editor.**

The **binary input status signals** of the loss of excitation protection function :

Binary status signal	Title	Explanation
UEX40_Blk_GrO_	Block	Blocking of the loss of excitation function
UEX40_VTSBlk_GrO_	Block from VTS	Blocking of the loss of excitation function from the VT supervision

Table 1-8 The binary input signals of the loss of excitation function

2.1.10.2.5. The function block

The function block of the loss of excitation protection function is shown in Figure 1-2. This block shows all binary input and output status signals that are applicable in the graphic equation editor.

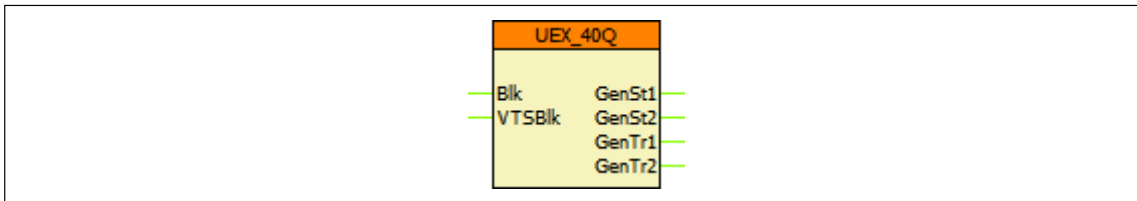
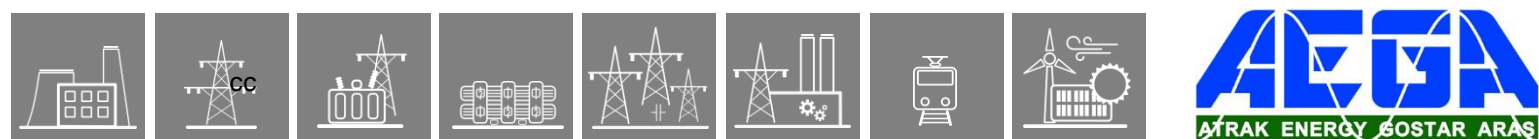

Figure 1-2 The function block of the loss of excitation function



2.1.10.3. Loss of excitation protection (Version 40Q)

2.1.10.3.1.1. Field of application

When a synchronous generator connected parallel to the network loses the excitation, or the field decreases below the permitted limit then the generated voltage decreases. At the same time the missing magnetizing reactive power is taken from the other generators and from the network. This state can be caused by the failure of the excitation system, the error of the voltage controller, or when the system is switched over from automatic excitation to manual control then the manual system is set to inappropriate state. The consequences are:

- The generator stator current increases to dangerous level,
- The reactive power is supplied by the other operating generators of the power station, and they get unwanted trip command, due to the increased current,
- The generator gets out of the synchronous state and
 - It operates as an asynchronous machine, causing power swing and additional heat generation,
 - Or the speed of the generator increases above the tolerable speed.

To prevent the dangers listed above, the generator without excitation should be tripped. This is the function of the loss of excitation protection.

2.1.10.3.1.2. Characteristics

This protection is traditionally a well-proven impedance protection with “offset MHO” characteristic. When it is applied, there is need for users to study the effects of generator loss of excitation on system operation and to evaluate the performance of the loss of excitation protection for each generator. In the setting guide presented here, it was not possible to consider the effects of all combinations of generator designs, voltage regulator characteristics, system parameters or the interaction effects of the other generators. These effects can only be completely determined by the study of a generator connected to a specific system.

The characteristic realized in the IED-EP+ device includes two offset MHO circles. This is shown in the impedance plane of Figure 1-1. The center of the circles is shifted along the negative X axis. The circles are defined by two additional points: one is the point near the origin of the impedance plane, the other one is the farthest point. Figure 1-1 shows these points with the titles applied in parameter setting.

The generator loss of excitation protection function operates, if the calculated impedance is within the circle.

The calculated impedance is the positive sequence impedance, calculated in the line-to-line loops:

$$Z_1 = \frac{UL1 - UL2}{IL1 - IL2}$$

$$Z_1 = \frac{UL2 - UL3}{IL2 - IL3}$$

$$Z_1 = \frac{UL3 - UL1}{IL3 - IL1}$$

The generator loss of excitation event is a symmetrical, three-phase phenomenon. Accordingly any of the formulas above calculate the positive sequence impedance. If the generator is not excited, this impedance tends to the reactance of the generator. With the positive direction explained above, it is a negative reactance, positioned within the circles.

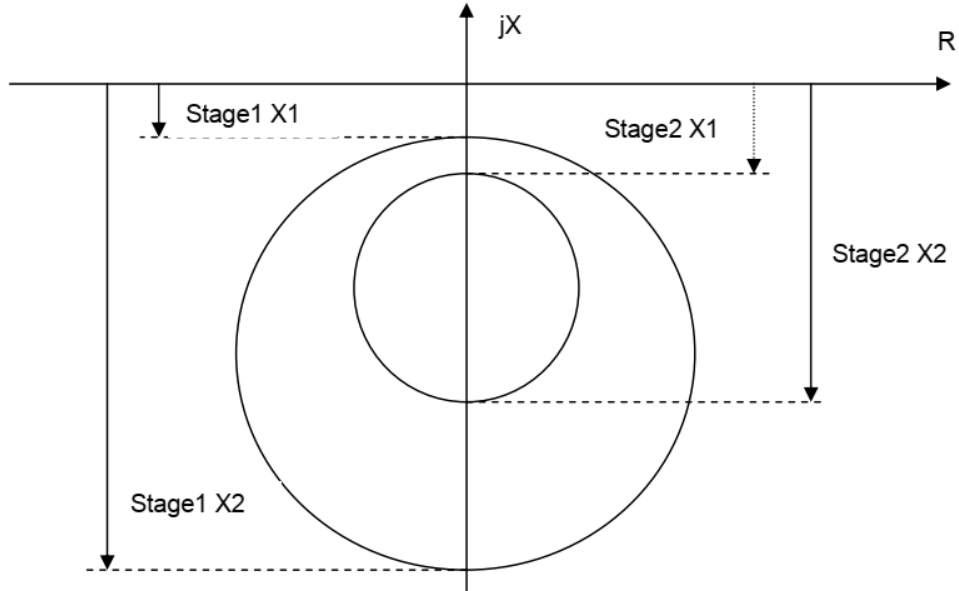

Figure 1-1 Characteristics of the loss of excitation function

In this guide it is supposed that the setting values in primary quantities are already decided, based on system simulations and experiences. It will be shown only, how the setting is realized in the IED-EP+ configurations.

The usual setting values of the characteristic parameters depend on the size and type of the generator, are the following:

		Small generator	Large generator	
			Lagging power factor only	Also leading power factor
Stage1	X1	0.5 Xd'	0.5 Xd'	0.75 Xd'
	X2	Xd	Xd	0.5 Xd
	T	1 - 5 s	0.5 - 10 s	0.5 - 10 s
Stage2	X1	n.a.	0.75 Xd'	0.75 Xd'
	X2	n.a.	U ² /S	U ² /S
	T	n.a.	0 s	0 s

where

- Xd' is the transient reactance of the generator,
- Xd is the synchronous reactance of the generator.

Table 1-1 General setting values of the characteristic

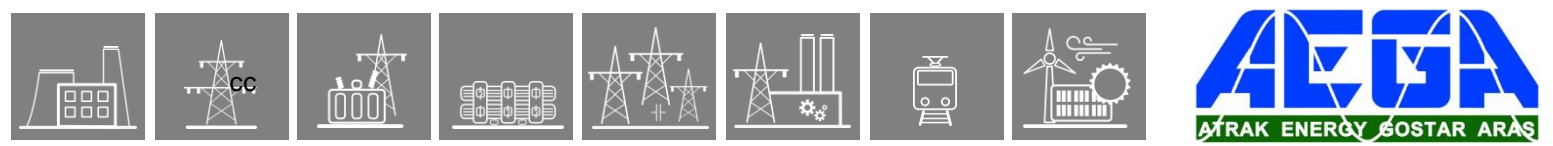

One circle (Stage 1) should be set with a diameter or the farthest point related to direct axis synchronous reactance (X_d) and some external time delay should be used to ride over the transient conditions that might cause undesirable operation. This setting will detect a loss of excitation when a generator is lightly loaded, a less severe condition. This circle is set with a setting of the nearest point equal to one-half direct axis transient reactance ($X'd/2$). If the generator can operate also in under-excited state, it is advised to decrease the operating area by decreasing the value of the farthest point and by increasing the offset. The decision is based on simulations and experiences.

The second circle (Stage 2) is usually set with a diameter equal to 1.0 per unit impedance on the machine base and this relay should generate a trip command without any added internal time delay. This stage will provide fast protection for a loss of excitation with high initial machine loadings, the more severe condition in terms of possible machine damage and adverse effects on the system.

This combination of stages will detect a loss of excitation due to an open or shorted field circuit from any initial generator loading and provides maximum security against undesired operations.

2.1.10.3.2. Basic parameter setting

2.1.10.3.2.1. Connection diagram

The generator loss of excitation protection function can be connected alternatively to CTs at the terminal or at the neutral end of the generator. Voltage is from the generator voltage transformers (VTs).

The voltage inputs are connected to phase-to-neutral voltages. The connection diagram is shown in Figure 2-1.

Note1: for the correct operation of the generator loss of excitation protection function, connect always Ph-N voltages to the voltage inputs. The Ph-Ph voltages, applied for the decision, are calculated internally. The fourth voltage input is not applied in the generator loss of excitation protection function.

Note2: The general positive direction for a generator is according to the normal power flow: out of the generator. The characteristic of the generator loss of excitation protection function is defined according to this positive direction. The current transformer sets, however, are prepared for the positive directions required for the differential protection (sum of the currents should be zero): both are directed towards the generator. Consequently, if the generator loss of excitation protection function is connected to the current transformers in the star point of the generator, this positive direction coincides with that of the power flow. If however the current transformers at the terminal of the generator are applied, the positive direction should be reverted by parameter setting. This setting is explained below.

Note3: The connection of the 3I₀ residual current is not needed for the generator loss of excitation protection function. Connect this current, if other functions need it.

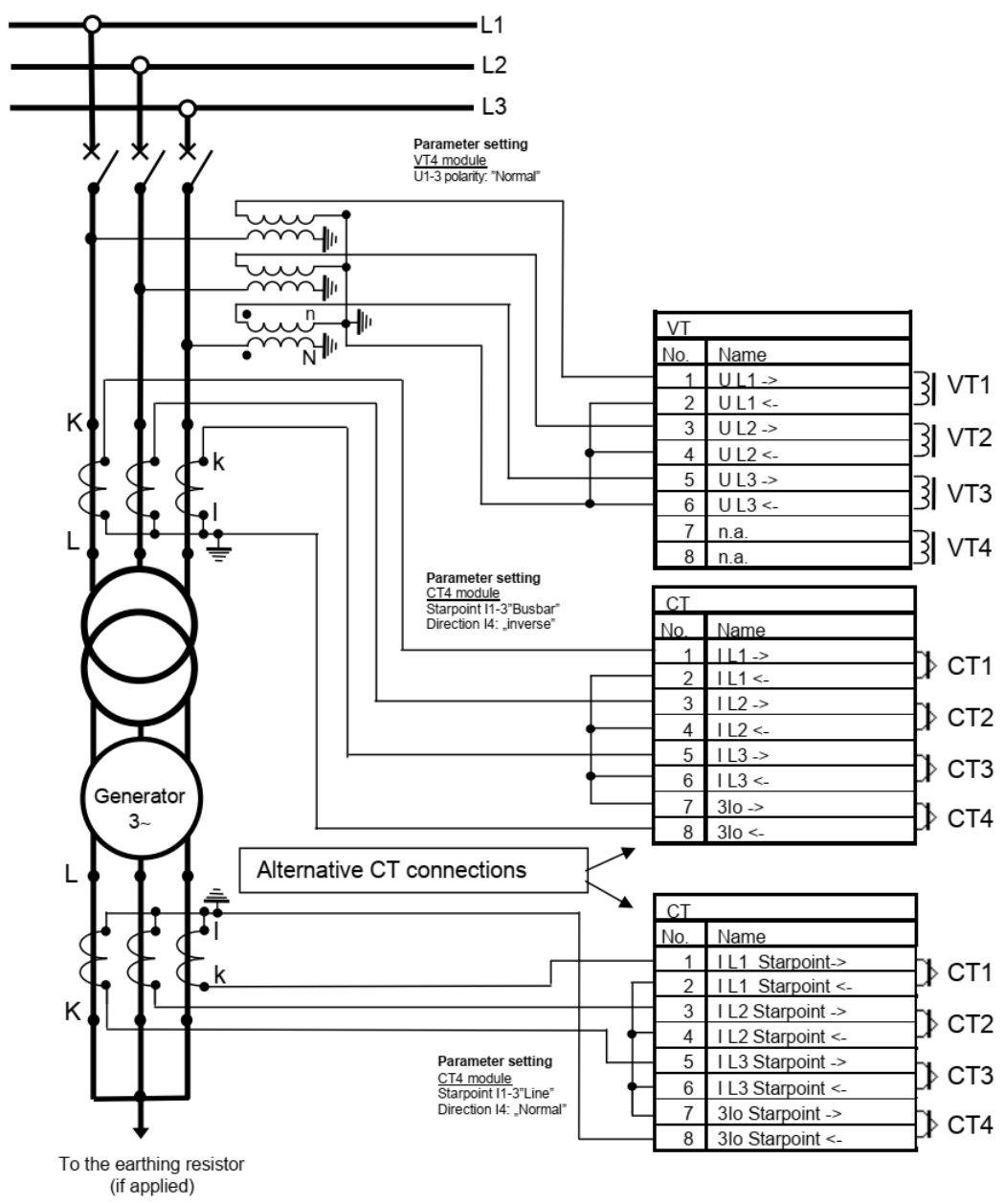

Figure 2-1 Connection diagram

2.1.10.3.2.2. Setting the parameters of the voltage input module

The corresponding parameter settings are explained in Table 2-1.

Parameter	Selection	Explanation
Range	Type 100	The type indicates the rated secondary voltage of the VT. This can be 100 V (in this example) or 200V. The displayed values in % are referring to this voltage.
Connection U1-3	Ph-N-Isolated	Connect always phase-to-neutral voltages to the inputs 1-3. Select "Ph-N-Isolated" as in case of earth-fault in not solidly grounded system, the Ph-N voltage can increase to Ph-Ph value. This selection is to provide optimal internal storage of the sampled voltage values.
Connection U4	n.a.	U4 input channel is not needed for the generator loss of excitation protection function. Set it according to the requirements of other functions.
Direction U1-3	Normal	The generator loss of excitation protection function has directionality; this parameter is influencing the operation of the function. If the inputs are applied as in the connection diagram of Figure 2-1, set it for "Normal". (The other choice would invert the sign of the calculated impedance.)
Direction U4	n.a.	U4 input channel is not needed for the generator loss of excitation protection function. Set it according to the requirements of other functions.
VT correction	100	This parameter is to correct the sampled values, if e.g. $U_{n_sec}=110V$ instead of 100V, set "VT correction = 110%".
Rated Primary U1-3	$15.75/\sqrt{3}$	Setting, according to the VT rated voltage, applied at the primary side. This parameter is used for scaling the displayed values only.
Rated Primary U4	n.a.	U4 input channel is not needed for the generator loss of excitation protection function. Set it according to the requirements of other functions.

Table 2-1 Example parameters for the voltage input function

2.1.10.3.2.3. Setting the parameters of the current input module

Connect the phase currents according to Figure 2-1. The figure shows two alternative connection possibilities, select one of them. The generator loss of excitation protection function is a directional function (based on calculated impedance); this selection determines the operation of the function.

The general positive direction for a generator is according to the normal power flow: out of the generator. The characteristic of the generator loss of excitation protection function references this positive direction. The current transformer sets however, are prepared for the positive directions required for the differential protection (sum of the currents should be zero): both are directed towards the generator. Consequently, if the generator loss of excitation protection function is connected to the current transformers in the star point of the generator, this positive direction coincides with that of the power flow. If however the current transformers at the terminal of the generator are applied, the positive direction should be reverted by parameter setting.

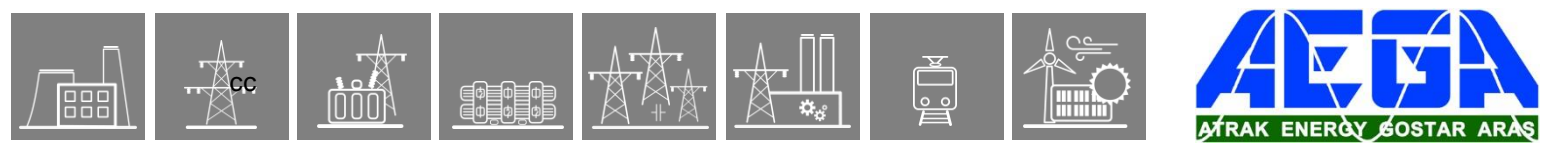

If the generator loss of excitation protection function is connected to the current transformers at the neutral point of the generator and the star point is toward the generator (see this alternative in Figure 2-1), then the correct setting for the “Starpoint” parameter is “Line”. (In case of the current transformer star point is at the star point of the generator, select the other setting choice: “Busbar”).

If the generator loss of excitation protection function is connected to the current transformers at the terminal of the generator and the star point is toward the generator (see this alternative in Figure 2-1), then the correct setting for the “Starpoint” parameter is “Busbar”. (In case of the current transformer star point is far from the generator, select the other setting choice: “Line”).

Note: The “Line” and “Busbar” choice reflects the directions related to a line distance protection.

Parameter	Selection	Explanation
Rated secondary I1-3	In_sec	Set the rated secondary current of the CT-s, e.g. 1A or 5A.
Rated secondary I4	n.a.	I4 input channel is not needed for the generator loss of excitation protection function. Set it according to the requirements of other functions.
Starpoint I1-3	Line	The generator loss of excitation protection function is a function with directionality, this parameter is decisive for the operation of the function. Set it according to the explanation above.
Direction I4	n.a.	I4 input channel is not needed for the generator loss of excitation protection function. Set it according to the requirements of other functions.
Rated Primary I1-3	In_prim	Setting, according to the CT rated current, applied at the primary side. This parameter is used for scaling the displayed values only.
Rated Primary I4	n.a.	I4 input channel is not needed for the generator loss of excitation protection function. Set it according to the requirements of other functions.

Table 2-2 Example parameters for the current input function

2.1.10.3.3. Parameter setting for the operating characteristics

2.1.10.3.3.1. Example data

The parameter setting for the operating characteristic will be demonstrated with the data of the synchronous machine in Table 3-1.

Parameter	Quantity	Unit	Value
Rated power	S_n	kVA	52600
Rated voltage	U_n	V	11000
Synchronous reactance	X_d	%	227
Direct axis transient reactance	X_d'	%	18.3
The generator is not designed to supply capacitive load (lagging power factor only)			
Voltage transformer	V_p/V_s	V/V	11000/100
Current transformer	I_p/I_s	A/A	3000/5

Table 3-1 Example data of a synchronous machine

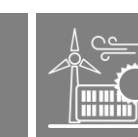
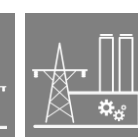
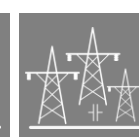
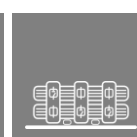
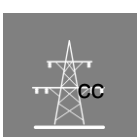

2.1.10.3.3.2. Parameters

Based on the consideration of Chapter 1.2 it is supposed that the characteristic values are decided according to Table 3-2 below.

Parameter	Setting according to:	Value	
Stage1	X1	0.5 Xd'	9.2 %
	X2	Xd	227 %
	T	0.5 – 10 s	3 s
Stage2	X1	0.75 Xd'	13.7%
	X2	U ² /S or 2Xd	454%
	T	0 s	02

Table 3-2 Example setting primary values

The primary values need to be related to the impedance, calculated using the rated values of the measuring transformers. This is explained below, using the measuring transformer data in Table 3-1.

Stage 1 X1

$$Stage1 X1 = 9.2 \% * \frac{Un^2}{S} * \frac{\sqrt{3} * InCT}{UnVT} = 9.2 \% * \frac{11000^2}{52600 * 10^3} * \frac{\sqrt{3}3000}{11000} = 10.0\%$$

Stage 1 X2

$$Stage1 X2 = 227\% * \frac{Un^2}{S} * \frac{\sqrt{3} * InCT}{UnVT} = 227\% * \frac{11000^2}{52600 * 10^3} * \frac{\sqrt{3}3000}{11000} = 246.7 \%$$

Stage 2 X1

$$Stage2 X1 = 13.7 \% * \frac{Un^2}{S} * \frac{\sqrt{3} * InCT}{UnVT} = 13.7 \% * \frac{11000^2}{52600 * 10^3} * \frac{\sqrt{3}3000}{11000} = 14.9 \%$$

Stage 2 X2

$$Stage2 X2 = 454 \% * \frac{Un^2}{S} * \frac{\sqrt{3} * InCT}{UnVT} = 454 \% * \frac{11000^2}{52600 * 10^3} * \frac{\sqrt{3}3000}{11000} = 493.3 \%$$

These calculated values, together with other parameters which do not need detailed explanation, are summarized in Table 3-3 below.

Parameter	Selection	Explanation
IPh Base Sens	20	Definition of minimal current enabling impedance calculation: 20% of the CT rated current
Stage1 Operation	On	To activate the function stage 1, set this parameter to "On"
Impedance Start Only	0	For stage 1: <ul style="list-style-type: none"> • (not checked) means generating trip signal • (checked) means generating start signal only
Stage1 X1	10.0%	Stage 1 reactance point of the circle near to the origin, calculated above
Stage1 X2	246.7%	Stage 1 reactance point of the circle far from the origin, calculated above
Stage1 Delay	3000	Time delay for stage 1 (ms)
Stage2 Operation	On	To activate the function stage 2, set this parameter to "On"
Impedance Start Only	0	For stage 2: <ul style="list-style-type: none"> • means generating trip signal • means generating start signal only
Stage2 X1	14.9%	Stage 2 reactance point of the circle near to the origin, calculated above
Stage2 X2	493.3%	Stage 2 reactance point of the circle far from the origin, calculated above
Stage2 Delay	0	Time delay for stage 2 (ms)

Table 3-3 Example setting values

2.1.10.3.3.3. Assignment of the binary signals

The **binary output status signals** of the generator loss of excitation protection function are listed in Table 3-4 below.

Binary status signal	Title	Explanation
UEX40_GenSt1_Grl_	Stage1 Start	General start signal of the first stage
UEX40_GenTr1_Grl_	Stage1 Trip	General trip signal of the first stage
UEX40_GenSt2_Grl_	Stage2 Start	General start signal of the second stage
UEX40_GenTr2_Grl_	Stage2 Trip	General trip signal of the second stage

Table 3-4 The binary output status signals of the generator loss of excitation protection function

2.1.11.5.3. The principal scheme of the impedance calculation

Figure 1-2 shows the principal scheme of the impedance calculation Z_CALC.

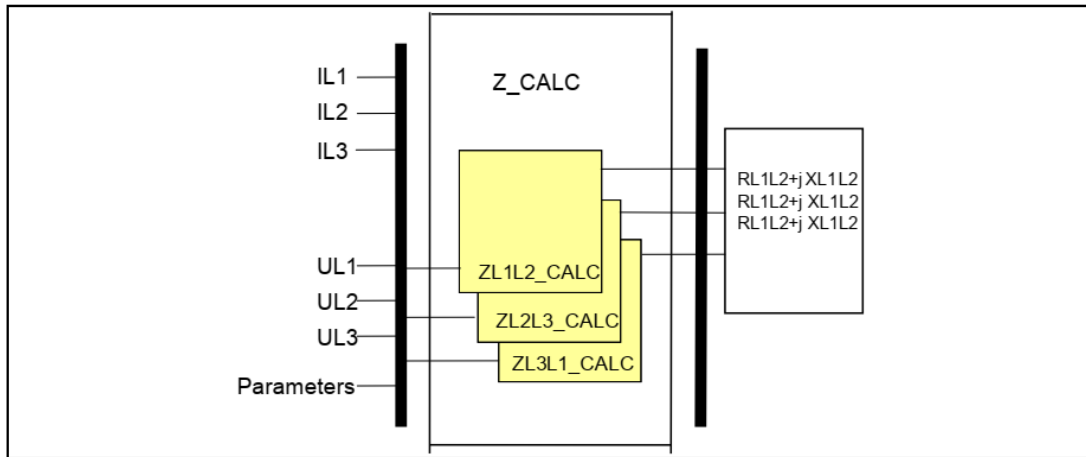

Figure 1-2 Principal scheme of the impedance calculation Z_CALC

The **inputs** are:

- the Fourier components of the three phase voltages,
- the Fourier components of the three phase currents,
- parameters.

The **outputs** are the calculated positive sequence impedances (R+jX) of the three measuring loops:

- Impedances of the three phase-phase loops,

The calculated values of the Z_CALC module

Calculated value	Dim.	Explanation
$RL1L2+j XL1L2$	ohm	Measured positive sequence impedance in the L1L2 loop
$RL2L3+j XL2L3$	ohm	Measured positive sequence impedance in the L2L3 loop
$RL3L1+j XL3L1$	ohm	Measured positive sequence impedance in the L3L1 loop

Table 1-2 The measured (calculated) values of the Z_CALC module

Z_CALC includes three practically identical software modules for impedance calculation:

- The three routines for the phase-to-phase loops get line-to-line voltages calculated from the sampled phase voltages and they get differences of the phase currents.

2.1.11.6. The characteristics of the loss of excitation protection function (OFFSET CIRCLE)

The method is an impedance-based comparison.

The operate decision is based on offset circle characteristics.

The calculated R_1 and $X_1 = \omega L_1$ co-ordinate values of the three measuring loops define three points on the complex impedance plane. These impedances are the positive sequence impedances in the measuring loops. The protection compares these points with the „offset circle” characteristics of the loss of excitation protection, shown for stage 1 in Figure 1-3. For stage 2 the characteristic is the same with independent parameters,

Parameter settings decide the size and the position of the circle. The center of the circle can be on the positive R and negative X quadrant of the impedance plane. The R offset and X offset values are defined to be positive in this quadrant.

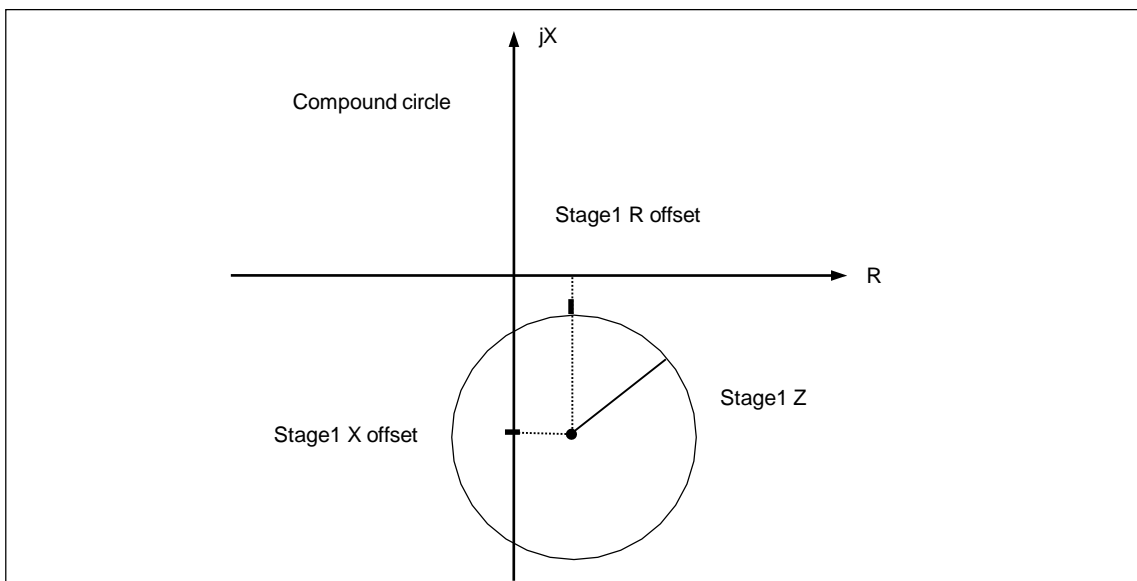

Figure 1-3 The offset circle characteristic

If a measured impedance point is inside the circle, the algorithm generates the true value of the related output binary signal.

The calculated impedance values are compared one by one with the setting values of the „offset circle” characteristics. This procedure is shown schematically in Figure 1-4.

The procedure is processed for each line-to-line loop. The result is the binary setting of three status variables. This indicates that the calculated impedance is within the processed „offset circle” characteristics.

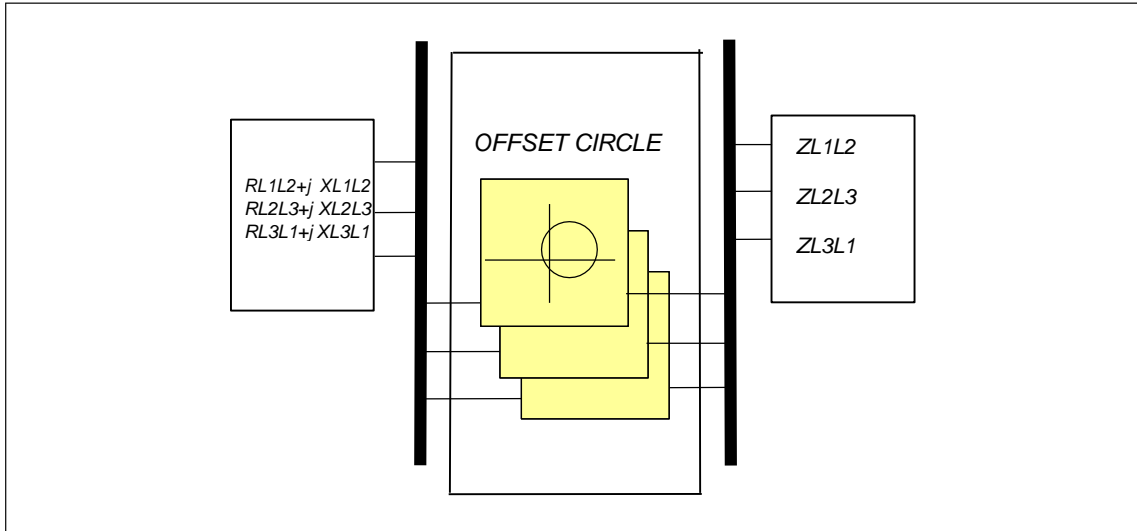

Figure 1-4 Principal scheme of the offset circle module

Input values

The input values are calculated by the module Z_CALC.

Input values	Explanation
RL1L2+j XL1L2	Calculated impedance in the measuring loop L1L2
RL2L3+j XL2L3	Calculated impedance in the measuring loop L2L3
RL3L1+j XL3L1	Calculated impedance in the measuring loop L3L1

Table 1-3 The input calculated impedances of the offset circle module

Output values

Input values	Explanation
ZL1L2_1	The impedance in the measuring loop L1L2 is inside the characteristics of stage 1
ZL2L3_1	The impedance in the measuring loop L2L3 is inside the characteristics of stage 1
ZL3L1_1	The impedance in the measuring loop L3L1 is inside the characteristics of stage 1
ZL1L2_2	The impedance in the measuring loop L1L2 is inside the characteristics of stage 2
ZL2L3_2	The impedance in the measuring loop L2L3 is inside the characteristics of stage 2
ZL3L1_2	The impedance in the measuring loop L3L1 is inside the characteristics of stage 2

Table 1-4 The output status signals of the offset circle module

The parameters needed in the characteristic evaluation procedure of the loss of excitation function are explained in the following table.



Float parameters

Parameter name	Title	Unit	Min	Max	Digits	Default
Radius of the circle of stage 1						
UEX_40Z_Z_1_FPar_	Stage1 Z	ohm	0.1	250	2	10.0
X offset of the circle of stage 1						
UEX_40Z_Z1_1_FPar_	Stage1 X offset	ohm	0.1	250	2	10.0
R offset of the circle of stage 1						
UEX_40Z_Z1_2_FPar_	Stage1 R offset	ohm	0.0	100	2	0.0
Radius of the circle of stage 2						
UEX_40Z_Z_2_FPar_	Stage2 Z	ohm	0.1	250	2	10.0
X offset of the circle of stage 2						
UEX_40Z_Z2_1_FPar_	Stage2 X offset	ohm	0.1	250	2	10.0
R offset of the circle of stage 2						
UEX_40Z_Z2_2_FPar_	Stage2 R offset	ohm	0.0	100	2	0.0

Table 1-5 The float parameters of the offset circle module

2.1.11.7. The trip logic (TRIP LOGIC) and timing

Binary inputs

Binary input signals from offset circle module	Explanation	
The started states generated by the offset circle module (these signals are not published)		
ZL1L2_1	The calculated impedance for the loop L1L2 is inside the characteristics of stage 1	
ZL2L3_1	The calculated impedance for the loop L2L3 is inside the characteristics of stage 1	
ZL3L1_1	The calculated impedance for the loop L3L1 is inside the characteristics of stage 1	
ZL1L2_2	The calculated impedance for the loop L1L2 is inside the characteristics of stage 2	
ZL2L3_2	The calculated impedance for the loop L2L3 is inside the characteristics of stage 2	
ZL3L1_2	The calculated impedance for the loop L3L1 is inside the characteristics of stage 2	
Impedance function start conditions generated by the I_COND module (these signals are not published)		
UEX_40Z_cL1_Grl_	I L1 condition	The current in phase L1 is sufficient for impedance calculation
UEX_40Z_cL2_Grl_	I L2 condition	The current in phase L2 is sufficient for impedance calculation
UEX_40Z_cL3_Grl_	I L3 condition	The current in phase L3 is sufficient for impedance calculation

Table 1-6 Binary input signals from the offset circle logic

Binary output status signals

Binary status signal	Title	Explanation
UEX_40Z_GenSt1_Grl_	General Start1	General start signal of the first stage
UEX_40Z_GenTr1_Grl_	General Trip1	General trip signal of the first stage
UEX_40Z_GenSt2_Grl_	General Start2	General start signal of the second stage
UEX_40Z_GenTr2_Grl_	General Trip2	General trip signal of the second stage

Table 1-7 Binary output signals of the trip logic

The **binary input status signals** of the trip logic:

Binary status signal	Title	Explanation
UEX_40Z_Blk_GrO_	Block	Blocking of the underexcitation protection function
UEX_40Z_VTSBlk_GrO_	Block from VTS	Blocking of the underexcitation protection function from the VT supervision function

Table 1-8 Binary input signals of the trip logic

Boolean parameters

Parameter name	Title	Default	Explanation
Boolean parameter to disable the trip command for stage 1			
UEX_40Z_StOnly1_BPar_	Stage1 Start Only	0	Set 0 value to generate also a trip signal for stage 1
Boolean parameter to disable the trip command for stage 2			
UEX_40Z_StOnly2_BPar_	Stage2 Start Only	0	Set 0 value to generate also a trip signal for stage 2

Table 1-9 The Boolean parameters of the trip logic

Enumerated parameters

Parameter name	Title	Selection range	Default
Parameter for disabling stage 1			
UEX_40Z_Op1_EPar_	Stage1 Operation	Off, On	Off
Parameter for disabling stage 1			
UEX_40Z_Op2_EPar_	Stage2 Operation	Off, On	Off

Table 1-10 The Enumerated parameters of the trip logic

Timer parameters

Parameter name	Title	Unit	Min	Max	Step	Default
Time delay for stage 1						
UEX_40Z_Del1_TPar_	Stage1 Delay	msec	50	60000	1	500
Time delay for stage 2						
UEX_40Z_Del2_TPar_	Stage2 Delay	msec	50	60000	1	500

Table 1-11 Timer parameters of the trip logic

2.1.11.8. The current conditions for the impedance calculation module (I_COND)

The impedance protection function can operate only if the current is sufficient for impedance calculation. This function performs this preliminary decision.

Binary output signals	Signal title	Explanation
Impedance function start conditions (these signals are not published)		
UEX_40Z_cIL1_Grl_	I L1 condition	The current in phase L1 is sufficient for impedance calculation
UEX_40Z_cIL2_Grl_	I L2 condition	The current in phase L2 is sufficient for impedance calculation
UEX_40Z_cIL3_Grl_	I L3 condition	The current in phase L3 is sufficient for impedance calculation

Table 1-12 The binary output status signals of the current conditions module

Integer parameter

Parameter name	Title	Unit	Min	Max	Step	Default
Definition of minimal current enabling impedance calculation:						
UEX_40Z_Imin_IPar_	I Ph Base Sens	%	10	30	1	20

Table 1-13 Integer parameter for the current conditions module

The current is considered to be sufficient for impedance calculation if it is above the level set by parameter UEX_40Z_Imin_IPar_ (I Ph Base Sens).

Float parameters

Parameter name	Title	Unit	Min	Max	Digits	Default
Radius of the circle of stage 1						
UEX_40Z_Z_1_FPar_	Stage1 Z	ohm	0.1	250	2	10.0
X offset of the circle of stage 1						
UEX_40Z_Z1_1_FPar_	Stage1 X offset	ohm	0.1	250	2	10.0
R offset of the circle of stage 1						
UEX_40Z_Z1_2_FPar_	Stage1 R offset	ohm	0.0	100	2	0.0
Radius of the circle of stage 2						
UEX_40Z_Z_2_FPar_	Stage2 Z	ohm	0.1	250	2	10.0
X offset of the circle of stage 2						
UEX_40Z_Z2_1_FPar_	Stage2 X offset	ohm	0.1	250	2	10.0
R offset of the circle of stage 2						
UEX_40Z_Z2_2_FPar_	Stage2 R offset	ohm	0.0	100	2	0.0

Table 1-18 The float parameters of the loss of excitation function

Timer parameters

Parameter name	Title	Unit	Min	Max	Step	Default
Time delay for stage 1						
UEX_40Z_Del1_TPar_	Stage1 Delay	msec	0	60000	1	500
Time delay for stage 2						
UEX_40Z_Del2_TPar_	Stage2 Delay	msec	0	60000	1	500

Table 1-19 The timer parameters of the loss of excitation function

2.1.11.9.3. Summary of the generated output signals

The binary output status signals of the circular impedance protection function:

Binary status signal	Title	Explanation
UEX_40Z_GenSt1_Grl_	General Start1	General start signal of the first stage
UEX_40Z_GenTr1_Grl_	General Trip1	General trip signal of the first stage
UEX_40Z_GenSt2_Grl_	General Start2	General start signal of the second stage
UEX_40Z_GenTr2_Grl_	General Trip2	General trip signal of the second stage

Table 1-20 The binary output status signals of the loss of excitation function

2.1.11.9.4. Summary of the input signals

Binary status signals

The loss of excitation function has binary input status signals. The conditions are defined by the user, applying the graphic equation editor.

The binary input status signals of the loss of excitation protection function are listed in Table 1-21.

Binary status signal	Title	Explanation
UEX_40Z_Blk_GrO_	Block	Blocking of the loss of excitation function
UEX_40Z_VTSBlk_GrO_	Block from VTS	Blocking of the loss of excitation function from the VT supervision

Table 1-21 The binary input signals of the loss of excitation function

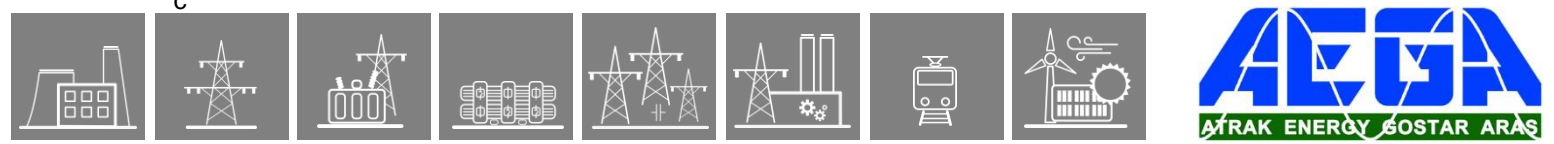

2.1.11.9.5. The function block

The function block of the loss of excitation protection function is shown in Figure 1-5. This block shows all binary input and output status signals that are applicable in the graphic equation editor.

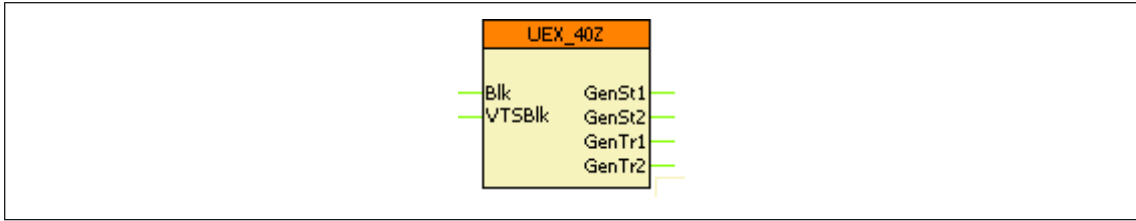

Figure 1-5 The function block of the loss of excitation function

2.1.12. Negative sequence overcurrent protection function

The negative sequence overcurrent protection function (TOC46) block operates if the negative sequence current is higher than the preset starting value.

In the negative sequence overcurrent protection function, definite-time or inverse-time characteristics are implemented, according to IEC or IEEE standards. The function evaluates a single measured current, which is the RMS value of the fundamental Fourier component of the negative sequence current. The characteristics are harmonized with IEC 60255-151, Edition 1.0, 2009-08.

2.1.12.1. Operating characteristics

2.1.12.1.1. Definite time characteristic

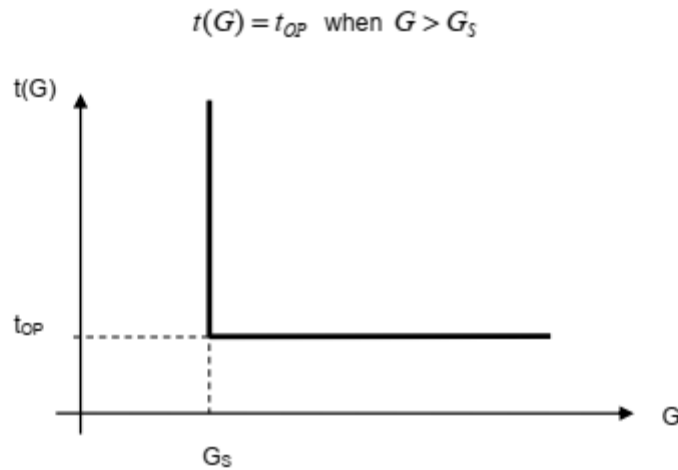

Figure 1-1 Overcurrent definite time characteristic

where	
t_{OP} (seconds)	theoretical operating time if $G > G_s$, fix, according to the preset parameter,
G	measured value of the characteristic quantity, Fourier base harmonic of the negative sequence current,
G_s	preset starting value of the characteristic quantity (TOC46_StCurr_IPar_, Start current).

2.1.12.1.2. Standard dependent time characteristics

Operating characteristics:

$$t(G) = TMS \left[\frac{k}{\left(\frac{G}{G_s}\right)^\alpha - 1} + c \right] \text{ when } G > G_s$$

where
 t(G)(seconds) theoretical operate time with constant value of G,
 k, c constants characterizing the selected curve (in seconds),
 α constant characterizing the selected curve (no dimension),
 G measured value of the characteristic quantity, Fourier base harmonic of the negative sequence current (INFour),
 G_s preset value of the characteristic quantity (TOC46_StCurr_IPar_, Start current),
 TMS preset time multiplier (no dimension).

	IEC ref		k _r	c	α
1	A	IEC Inv	0,14	0	0,02
2	B	IEC VeryInv	13,5	0	1
3	C	IEC ExtInv	80	0	2
4		IEC LongInv	120	0	1
5		ANSI Inv	0,0086	0,0185	0,02
6	D	ANSI ModInv	0,0515	0,1140	0,02
7	E	ANSI VeryInv	19,61	0,491	2
8	F	ANSI ExtInv	28,2	0,1217	2
9		ANSI LongInv	0,086	0,185	0,02
10		ANSI LongVeryInv	28,55	0,712	2
11		ANSI LongExtInv	64,07	0,250	2

Table 1-1 The constants of the standard dependent time characteristics

The end of the effective range of the dependent time characteristics (G_D) is:

$$G_D = 20 * G_s$$

Above this value the theoretical operating time is definite:

$$t(G) = TMS \left[\frac{k}{\left(\frac{G_D}{G_s}\right)^\alpha - 1} + c \right] \text{ when } G > G_D = 20 * G_s$$

The inverse characteristic is valid above G_T = 1,1 * G_s. Above this value the function is guaranteed to operate.



Resetting characteristics:

$$t_r(G) = TMS \left[\frac{k_r}{1 - \left(\frac{G}{G_s}\right)^\alpha} \right] \text{ when } G < G_s$$

where
 $t_r(G)$ (seconds) theoretical reset time with constant value of G,
 k_r constants characterizing the selected curve (in seconds),
 α constant characterizing the selected curve (no dimension),
 G measured value of the characteristic quantity, Fourier base harmonic of the phase current,
 G_s preset starting value of the characteristic quantity (TOC51_StCurr_IPar_, Start current),
 TMS preset time multiplier (no dimension).

	IEC ref		k_r	α
1	A	IEC Inv	Resetting after fix time delay, according to preset parameter	
2	B	IEC VeryInv	TOC46_Reset_TPar_	
3	C	IEC ExtInv	"Reset delay"	
4		IEC LongInv	0,46	2
5		ANSI Inv	4,85	2
6	D	ANSI ModInv	21,6	2
7	E	ANSI VeryInv	29,1	2
8	F	ANSI ExtInv	4,6	2
9		ANSI LongInv	13,46	2
10		ANSI LongVeryInv	30	2
11		ANSI LongExtInv		

Table 1-2 The resetting constants of the standard dependent time characteristics

The inverse type characteristics are also combined with a minimum time delay, the value of which is set by user parameter TOC46_MinDel_TPar_ (Min. Time Delay).

2.1.12.2. Structure of the negative sequence overcurrent protection algorithm

Fig.1-1 shows the structure of the negative sequence overcurrent protection (TOC46) algorithm.

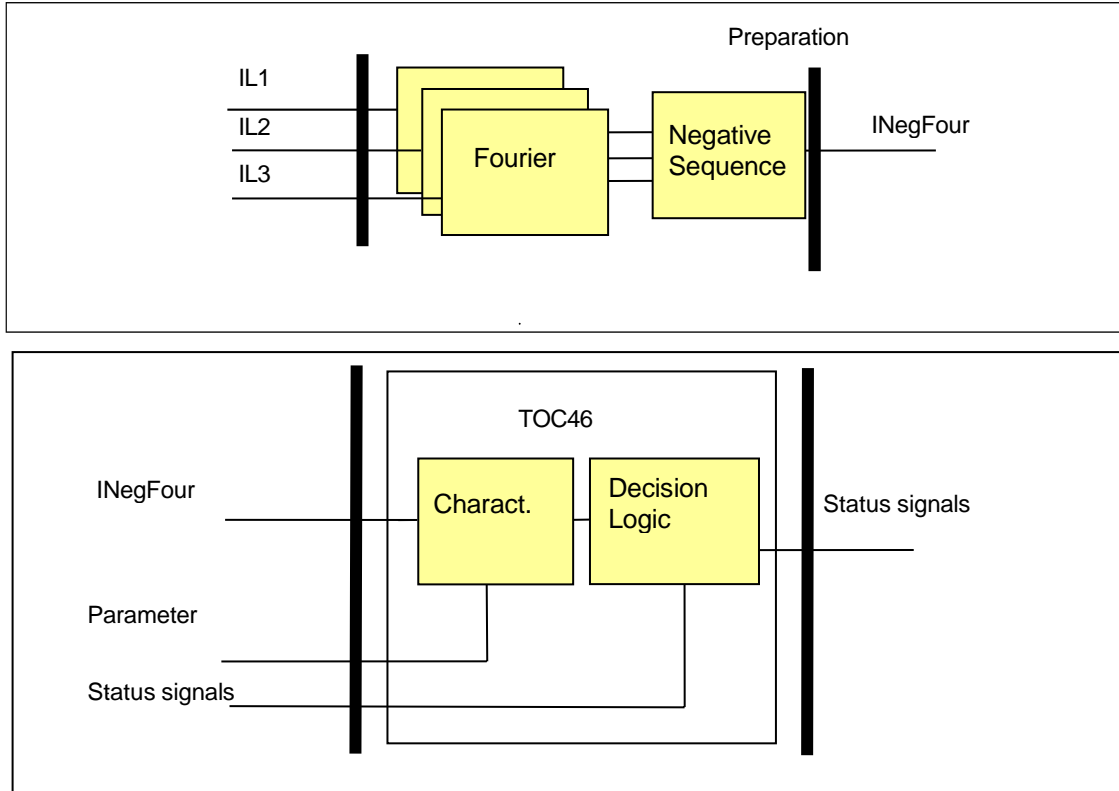

Figure 1-1 Structure of the negative sequence overcurrent protection algorithm

For the preparation (not part of the TOC46 function):

The **inputs** are

- the sampled values of the three phase currents (IL1, IL2, IL3),

The **output** is

- the RMS value of the fundamental Fourier components of the negative sequence component of the phase currents.

For the TOC46 function:

The **inputs** are

- the RMS value of the fundamental Fourier component of the negative sequence component of the phase currents,
- parameters,
- status signals.

The **outputs** are

- the binary output status signals.



The **software modules** applied in the negative sequence overcurrent protection function are:

Fourier calculations

These modules calculate the basic Fourier current components of the phase currents.

Negative sequence

This module calculates the basic Fourier current components of the negative sequence current, based on the Fourier components of the phase currents.

Characteristics

This module calculates the required time delay based on the Fourier components of the negative sequence current.

Decision logic

The decision logic module combines the status signals to generate the trip command of the function.

The following description explains the details of the individual components.

2.1.12.3. The Fourier calculation (Fourier)

These modules calculate the basic Fourier current components of the phase currents individually. These modules belong to the preparatory phase.

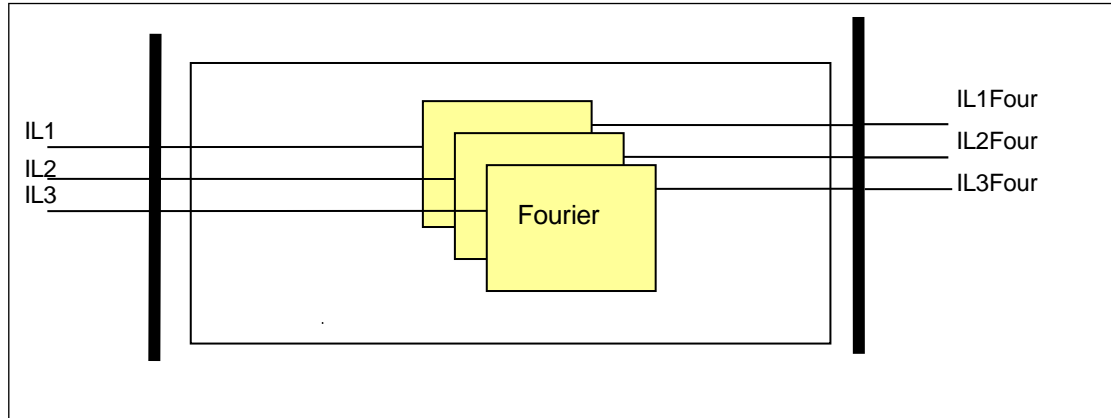

Figure 1-2 Schema of the Fourier calculation

The **inputs** are the sampled values of:
The three phase currents of the primary side (IL1, IL2, IL3)

The **outputs** are the basic Fourier components of the analyzed currents (IL1Four, IL2Four, IL3Four).



2.1.12.4. The negative phase sequence calculation (Negative sequence)

This module calculates the negative phase sequence components based on the Fourier components of the phase currents. This module belongs to the preparatory phase.

The **inputs** are the basic Fourier components of the phase currents (IL1Four, IL2Four, IL3Four).

The **output** is the basic Fourier component of the negative sequence current component (INegFour).

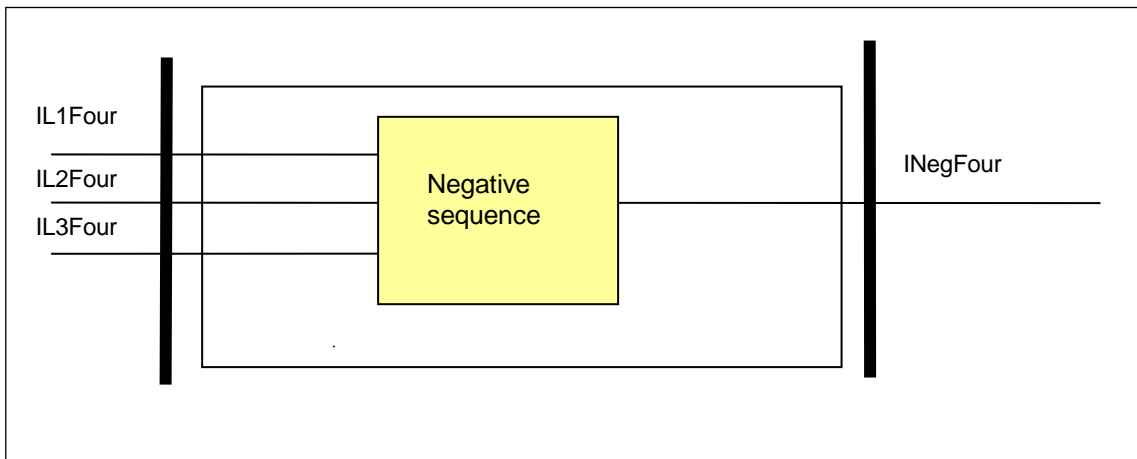

Figure 1-3 Schema of the negative sequence component calculation

2.1.12.5. The definite time and the inverse type characteristics (Characteristics)

This module calculates the required time delay based on the Fourier components of the negative sequence current. The formulas applied are described in Chapter 1.1.

The **input** is the basic Fourier component of the negative sequence current (INegFour) and parameters.

The **outputs** are the internal status signals of the function. These indicate the started state and the generated trip command if the time delay determined by the characteristics expired.

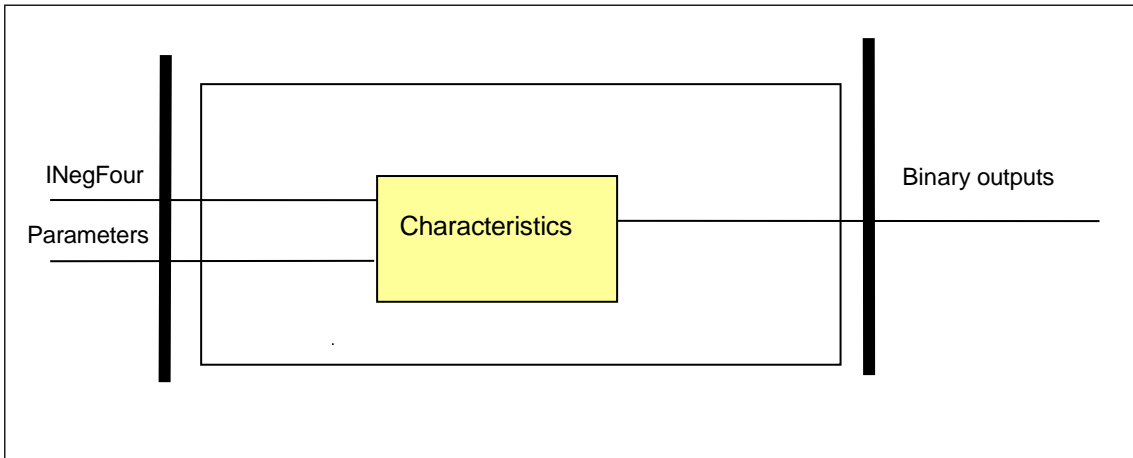

Figure 1-4 Schema of the characteristic calculation

Enumerated parameter

Parameter name	Title	Selection range	Default
Parameter for type selection			
TOC46_Oper_EPar_	Operation	Off, DefinitTime, IEC Inv, IEC VeryInv, IEC ExtInv, IEC LongInv, ANSI Inv, ANSI ModInv, ANSI VeryInv, ANSI ExtInv, ANSI LongInv, ANSI LongVeryInv, ANSI LongExtInv	Off

Table 1-3 The enumerated parameters of the negative sequence overcurrent protection function

Integer parameter

Parameter name	Title	Unit	Min	Max	Step	Default
Starting current parameter:						
TOC46_StCurr_IPar_	Start Current	%	10	1000	1	50

Table 1-4 The integer parameters of the negative sequence overcurrent protection function

Float parameter

Parameter name	Title	Unit	Min	Max	Step	Default
Time multiplier of the inverse characteristics (OC module)						
TOC46_Multip_FPar_	Time Multiplier		0.05	15	0.01	1.0

**Valid for inverse type characteristics*

Table 1-5 The Float parameter of the negative sequence overcurrent protection

Timer parameters

Parameter name	Title	Unit	Min	Max	Step	Default
Minimal time delay for the inverse characteristics:						
TOC46_MinDel_TPar_	Min Time Delay*	msec	40	60000	1	100
Definite time delay:						
TOC46_DefDel_TPar_	Definite Time Delay**	msec	40	60000	1	100
Reset time delay for the inverse characteristics:						
TOC46_Reset_TPar_	Reset Time*	msec	60	60000	1	100

**Valid for inverse type characteristics*

***Valid for definite type characteristics only*

Table 1-6 The timer parameters of the characteristics calculation module

The **binary output status signals** of the of the characteristics calculation module are listed in Table 1-7.

Binary output signals	Signal title	Explanation
TOC46_St_Grl_	Start Neg	Starting of the function
TOC46_Tr_Grl_	Trip Neg	Trip command of the function

Table 1-7 The binary output status signals of the characteristics calculation module

2.1.12.6. The decision logic (Decision logic)

The decision logic module combines the binary status signals to generate the trip command of the function.

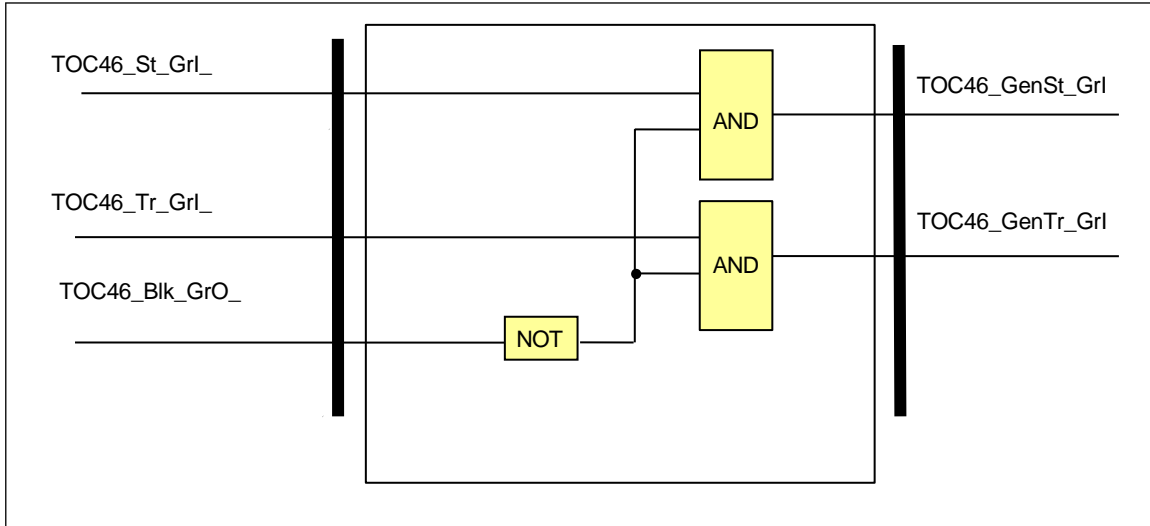

Figure 1-5 The logic scheme of the negative sequence overcurrent protection function

Binary status signals	Signal title	Explanation
TOC46_St_Grl_	Start	Starting of the function
TOC46_Tr_Grl_	Trip	Trip command of the function

Table 1-8 The binary status signals of the decision logic

Binary input status signal

The negative sequence overcurrent protection function has a binary input signal, which serves the purpose of disabling the function. **The conditions of disabling are defined by the user, applying the graphic equation editor.**

Binary input status signal	Explanation
TOC46_Blkl_GrO_	Output status of a graphic equation defined by the user to disable the negative sequence overcurrent protection function.

Table 1-9 The binary input signal of the negative sequence overcurrent protection function

Binary output signals	Signal title	Explanation
TOC46_GenSt_Grl_	General Start	General starting of the function
TOC46_GenTr_Grl_	General Trip	General trip command of the function

Table 1-10 The binary output status signals of the negative sequence overcurrent protection function

2.1.12.7. Technical summary

2.1.12.7.1. Technical data

Function	Value	Accuracy
Operating accuracy	$10 \leq G_s [\%] \leq 200$	< 2 %
Operate time accuracy		±5% or ±15 ms, whichever is greater
Reset ratio	0,95	

2.1.13. Negative sequence overcurrent protection function for generators

In case of asymmetrical faults on the connected network or at asymmetrical load states, the stator current of the generators is asymmetric. The negative sequence component of the stator current generates an inverse rotating magnetic field, and it causes eddy currents in the rotor. These phenomena can cause overheating and damages.

The fact fault clearing is the task of the fault protection. In case of continuous asymmetry however it is the negative sequence overcurrent protection function which prevents damages of the generator.

The negative sequence overcurrent protection function (asymmetry protection) is a special inverse minimum time characteristic overcurrent protection function, operating based on the negative sequence current component, calculated by the internal algorithm. It integrates the square of the I_2 negative sequence current component. Accordingly this „memory function” remembers the heat generated during the previous state of the machine. The starting value of the very inverse time characteristic is setting parameter „ I_2 integration”. In case of extremely high negative sequence current component this characteristic is a horizontal line (definite minimum time section of the IDMT = inverse definite minimum time characteristic). This minimum time delay can be set, using the „*Minimum time delay*” parameter. The slope of the characteristic, i.e. the speed of the integration is defined by a characteristic point. This is trip time defined in seconds, when the negative sequence current component is the rated current of the generator. The identifier of this parameter is: „*K*”.

The rated current of the generator is a setting value, defined as percentage of the rated value of the current transformer. („*Generator rated current*” [$I_n / I_n(\text{CT})$ %]). The basis of all other current parameters is this value.

The integration of the negative sequence current component starts is the current gets above the threshold value. If the current drops below this value then the integral value decreases with a cooling time constant (parameter: „*Cooling time*”). This cooling is not exponential, but it is linear, which means the time, during which a 100% integral value decreases to zero along a straight characteristic line.

The changing of the integral value can be supervised among the on-line information of the function.

[-] Unbalanced Load	
Warning Start	<input checked="" type="checkbox"/>
Warning Signal	<input checked="" type="checkbox"/>
General Start	<input checked="" type="checkbox"/>
General Trip	<input type="checkbox"/>
I2 Integral	27.6 %

Figure 1-1 On-line information

If the function is tested using injected current then the integration goes on even after trip command generation, but it stops at 200 %. At zero injected current, the integral decreases, starting from this value. The trip command resets below 90 %.

2.1.13.1.3. Binary output status signals

The **binary output status signals** of the negative sequence overcurrent protection function are listed in Table below

Binary output signals	Signal title	Explanation
TOC46G_GenSt_Grl_	General Start	General starting of the function
TOC46G_GenTr_Grl_	General Trip	General trip command of the function
TOC46G_WarnSt_Grl_	Warning Start	Start of the warning stage
TOC46G_WarnTr_Grl_	Warning Signal	“Trip” of the warning stage

Table 1-6 The binary output status signals of the negative sequence overcurrent protection function

2.1.13.1.4. Binary input status signals

Binary input signals

The negative sequence overcurrent protection function has a binary input signal, which serves the purpose of disabling the function. **The conditions of disabling are defined by the user, applying the graphic equation editor.**

Binary input signal	Explanation
TOC46G_BlK_GrO_	Output status of a graphic logic defined by the user to disable the negative sequence overcurrent protection function.

Table 1-7 The binary input signal of the negative sequence overcurrent protection function

2.1.13.1.5. Function block

The function block of the negative sequence overcurrent protection function is shown in Figure 1-2. This block shows all binary input and output status signals that are applicable in the graphic equation editor.

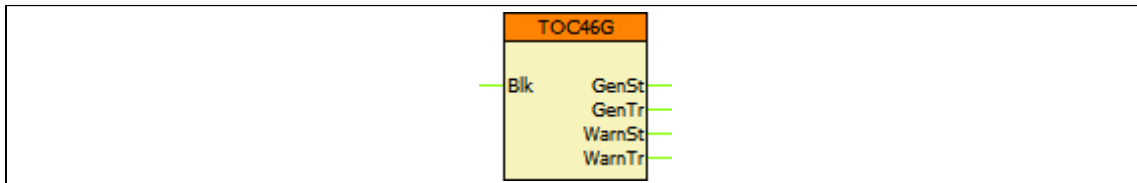

Figure 1-2 The function block of the negative sequence overcurrent protection function

2.1.14.4. Structure of the negative sequence definite time overvoltage protection algorithm

Fig.1-2 shows the structure of the negative sequence definite time overvoltage protection (TOV47) algorithm.

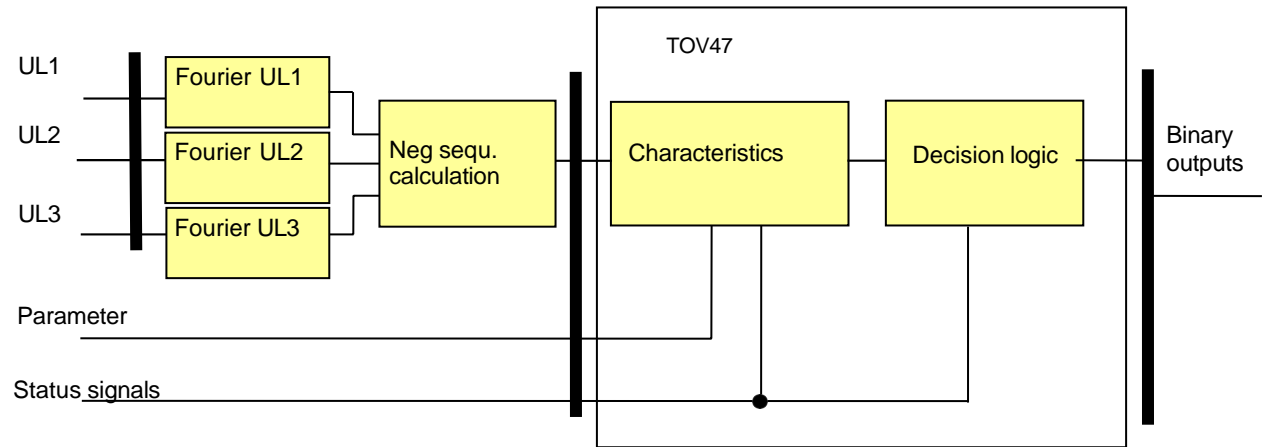

Figure 1-2 Structure of the negative sequence definite time overvoltage protection algorithm

The **inputs** are

- the RMS value of the negative sequence fundamental Fourier component, calculated using the sampled three phase voltages,
- parameters,
- status signals.

The **outputs** are

- the binary output status signals.

The **software modules** of the definite time overvoltage protection function:

Fourier calculations

These modules calculate the basic Fourier components of the phase voltages individually (not part of the TOV47 function).

Neg sequ. calculation

This module calculates the negative sequence basic Fourier component (not part of the TOV47 function).

Characteristics

This module calculates the required time delay based on the Fourier components of the negative sequence voltage component.

Decision logic

The decision logic module combines the status signals to generate the trip command of the function.

The following description explains the details of the individual components.

2.1.14.5. The Fourier calculation (Fourier)

These modules calculate the basic Fourier components of the phase voltages individually. They are not part of the TOV47 function; they belong to the preparatory phase.

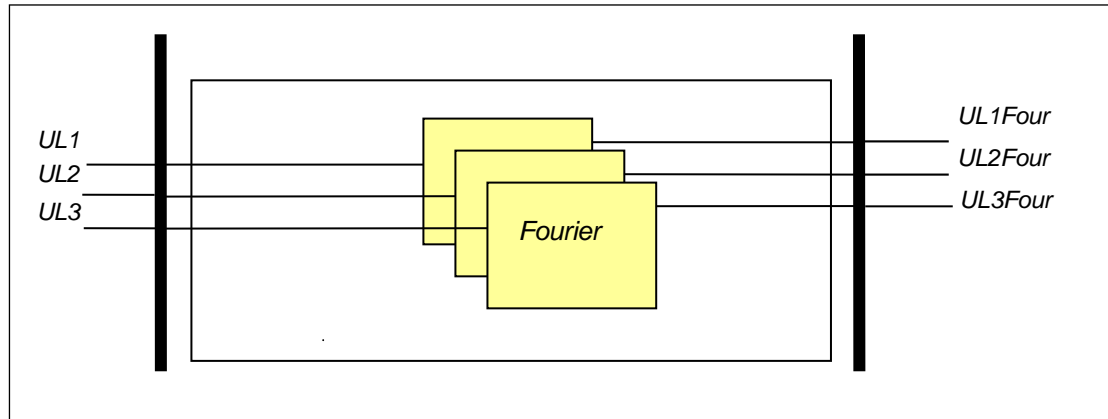

Figure 1-3 Schema of the Fourier calculation

The **inputs** are the sampled values of the three phase voltages (UL1, UL2, UL3)

The **outputs** are the RMS values of the basic Fourier components of the analyzed voltages (UL1Four, UL2Four, UL3Four).

2.1.14.6. The negative sequence component calculation (Neg sequ. Calculation)

This module calculates the negative sequent basic Fourier component. This is not part of the TOV47 function; it belongs to the preparatory phase.

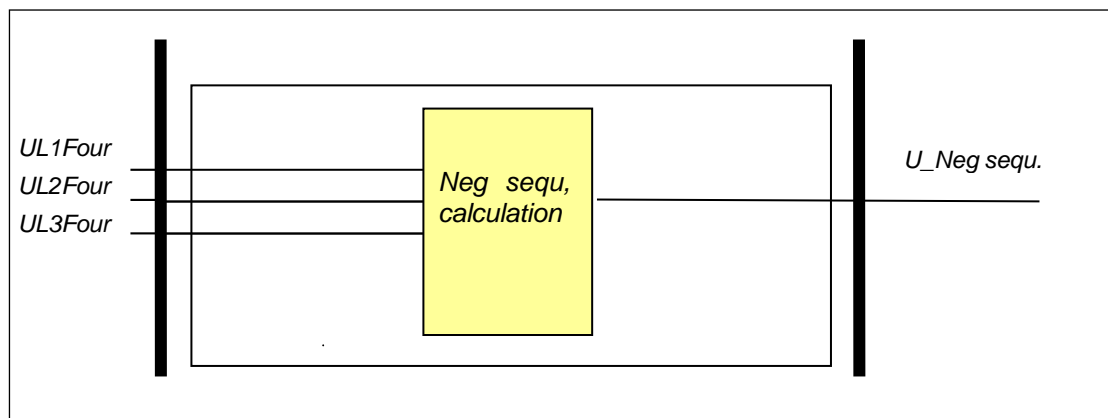

Figure 1-4 Schema of the negative sequence component calculation

The **inputs** are the RMS values of the basic Fourier components of the analyzed voltages (UL1Four, UL2Four, UL3Four).

The **output** is the RMS value of the negative sequence basic Fourier component voltage (U_Neg sequ.).

2.1.14.7. The definite time characteristics (Characteristics)

This module decides the stating of the function based on the negative sequence Fourier component voltage and it counts the time delay. The time delay is defined by the parameter setting, if the voltage is above the threshold value.

The **inputs** are the RMS value of the negative sequence basic Fourier component (U_neg sequ.) and parameters.

The internal **outputs** are the status signals. These indicate the started state and the generated trip command if the time delay determined by the setting is expired.

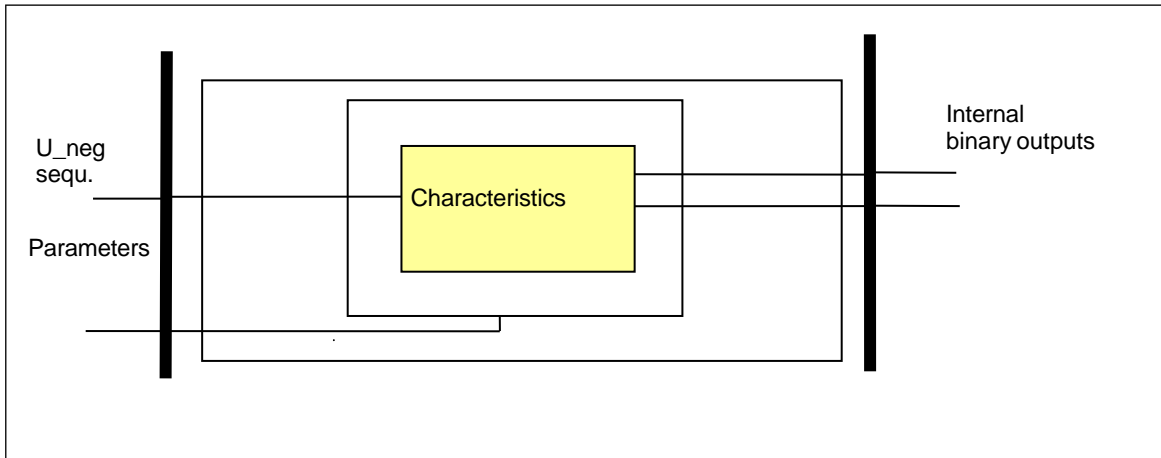

Figure 1-5 Schema of the definite time characteristic calculation

Integer parameter

Parameter name	Title	Unit	Min	Max	Step	Default
Voltage level setting. If the voltage is above the setting value, the function generates a start signal.						
TOV47_StVol_IPar__	Start Voltage	%	2	40	1	30

Table 1-1 Integer parameters of the negative sequence overvoltage protection function

Timer parameter

Parameter name	Title	Unit	Min	Max	Step	Default
Time delay of the overvoltage protection function.						
TOV47_Delay_TPar_ _	Time Delay	ms	50	60000	1	100

Table 1-2 The timer parameter of the negative sequence overvoltage protection function

The internal **binary output status signals** of the three-phase definite time overvoltage protection function are listed in Table 1-3 below.

Binary output signals	Signal title	Explanation
Start	Start	Starting of the function
Trip	Trip	Trip command of the function

Table 1-3 The internal binary output status signals of the negative sequence definite time overvoltage protection function

2.1.14.8. The decision logic (Decision logic)

The decision logic module combines the internal status signals, Boolean and binary parameters to generate the trip command of the function.

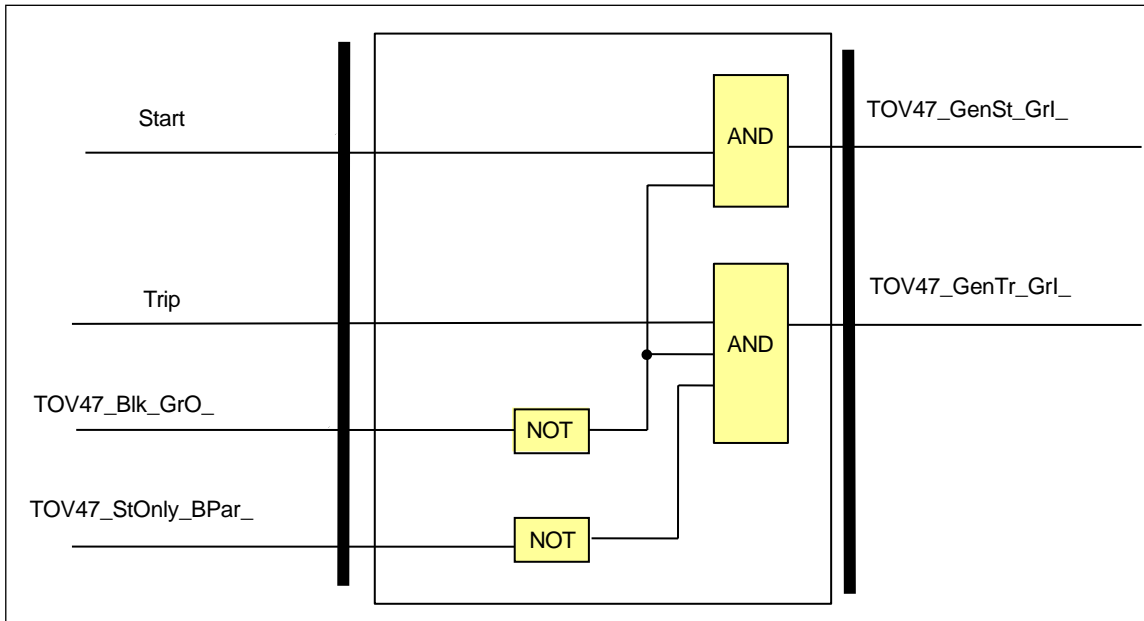

Figure 1-6 The decision logic scheme of the negative sequence definite time overvoltage protection function

Boolean parameter

Parameter name	Title	Default
Enabling start signal only:		
TOV47_StOnly_BPar_	Start Signal Only	FALSE

Table 1-4 The Boolean parameter of the negative sequence definite time overvoltage protection function

The negative sequence overvoltage protection function has a binary input signal, which serves the purpose of disabling the function. **The conditions of disabling are defined by the user, applying the graphic equation editor.**

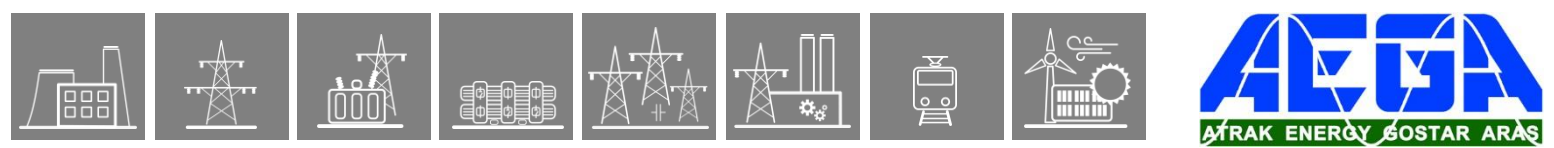

Binary input status signal

Binary status signal	Explanation
TOV47_Blk_GrO_	Output status of a graphic editor defined by the user to disable the negative sequence definite time overvoltage protection function.

Table 1-5 The binary input signal of the negative sequence definite time overvoltage protection function

Binary output status signals

Binary status signal	Title	Explanation
TOV47_GenSt_GrI_	General Start	General start signal
TOV47_GenTr_GrI_	General Trip	General trip command

Table 1-6 The binary output status signals of the negative sequence definite time overvoltage protection function

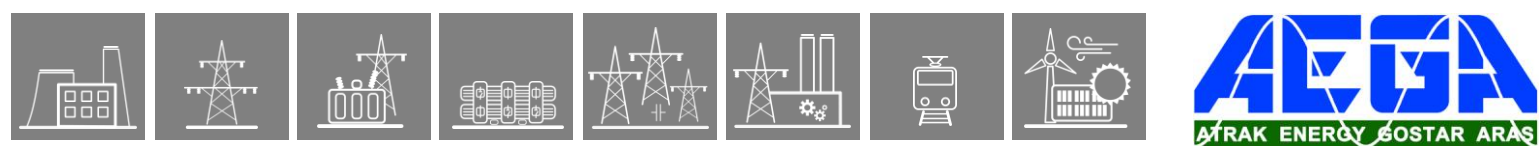

2.1.14.9. Technical summary

2.1.14.9.1. Technical data

Function	Value	Accuracy
Pick-up starting accuracy		< ± 0,5 %
Blocking voltage		< ± 1,5 %
Reset time		
U> → Un	60 ms	
U> → 0	50 ms	
Operate time accuracy		< ± 20 ms
Drop-off ratio		± 0.5 %
Minimum operate time	50 ms	

Table 1-7 Technical data of the negative sequence definite time overvoltage protection function

2.1.14.9.2. The parameters

The parameters are summarized in Chapter 1.7 Table 1-1, Table 1-2, and in Chapter 1.8 Table 1-4.

2.1.14.9.3. The status signals

The status signals are summarized in Chapter 1.8 Table 1-5 and Table 1-6.

2.1.14.9.4. The function block

The function block of the overvoltage protection function is shown in Figure 1-7. This block shows all binary input and output status signals that are applicable in the graphic logic editor.

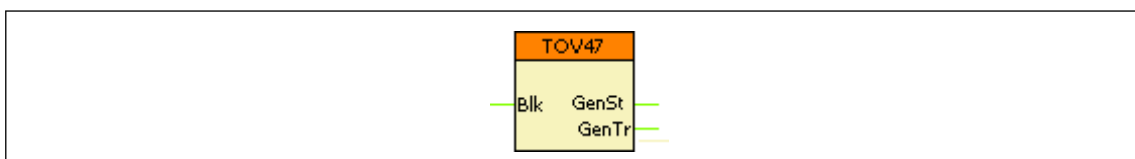
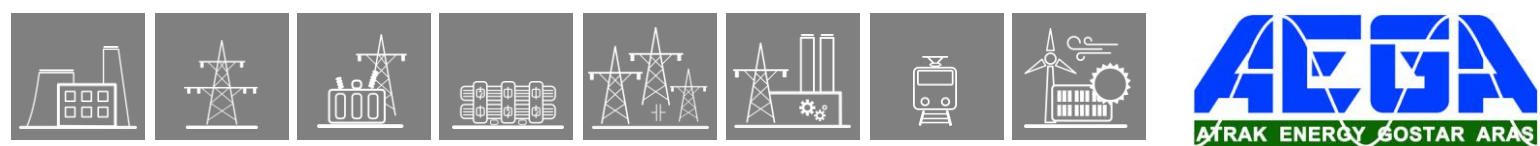

Figure 1-7 The function block of the negative sequence definite time overvoltage protection function



2.1.15. Line thermal protection function

Basically, line thermal protection measures the three sampled phase currents. RMS values are calculated and the temperature calculation is based on the highest RMS value of the phase currents.

The temperature calculation is based on the step-by-step solution of the thermal differential equation. This method yields “overtemperature”, meaning the temperature above the ambient temperature (of the environment). Accordingly, the temperature of the protected object is the sum of the calculated “overtemperature” and the ambient temperature.

The ambient temperature can be measured using e.g. a temperature probe generating electric analog signals proportional to the temperature. In the absence of such measurement, the temperature of the environment can be set using the dedicated parameter TTR49L_Amb_IPar_ (Ambient Temperature). The selection between parameter value and direct measurement is made by setting the binary parameter TTR49L_Sens_BPar_ (Temperature sensor). (Special HW input module is required.)

If the calculated temperature (calculated “overtemperature”+ambient temperature) is above the threshold values, status signals are generated:

TTR49L_Alm_IPar_ (Alarm temperature) TTR49L_Trip_IPar_ (Trip temperature)
TTR49L_Unl_IPar_ (Unlock temperature)

For correct setting, the following values must be measured and set as parameters:

TTR49L_Inom_IPar_ (Rated load current: continuous current applied for the measurement)
TTR49L_Max_IPar_ (Rated temperature: the steady state temperature at rated load current)
TTR49L_Ref_IPar_ (Base Temperature: the temperature of the environment during the measurement of the rated values)
TTR49L_pT_IPar_ (time constant: measured heating/cooling time constant of the exponential temperature function)

When energizing the protection device, the algorithm permits the definition of the starting temperature as the initial value of the calculated temperature:

TTR49L_Str_IPar_ (Startup Temp.: Initial temperature above the temperature of the environment as compared to the rated temperature above the base temperature)

The problem of metal elements (the protected line) exposed to the sun is that they are overheated as compared to the „ambient” temperature even without a heating current; furthermore, they are cooled mostly by the wind and the heat transfer coefficient is highly dependent on the effects of the wind. As the overhead lines are located in different geographical environments along the tens of kilometers of the route, the effects of the sun and the wind cannot be considered in detail. The best approximation is to measure the temperature of a piece of overhead line without current but exposed to the same environmental conditions as the protected line itself.

The application of thermal protection of the overhead line is a better solution than a simple overcurrent-based protection because thermal protection “remembers” the preceding load states of the line and the setting of the thermal protection does not need so a high security margin between the permitted current and the permitted continuous thermal current of the line. In a broad range of load states and in a broad range of ambient temperatures this

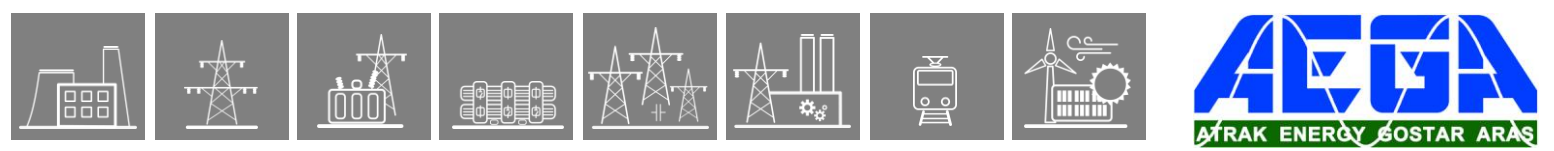

permits the better exploitation of the thermal and consequently current carrying capacity of the line.

2.1.15.1. Theory of the thermal replica calculations

2.1.15.1.1. The thermal differential equation

The theory of solving the thermal differential equation is described and explained in detail in the document [“The thermal differential equation”].

The source of the formulas below is that document. The

thermal differential equation to be solved is:

$$\frac{d\Theta}{dt} = \frac{1}{T} \left(\frac{I^2(t)R}{hA} - \Theta \right) \quad (1)$$

The definition of the heat time constant is:

$$T = \frac{cm}{hA}$$

In this differential equation:

- I(t) (RMS) heating current, the RMS value usually changes over time;
- R resistance of the line;
- c specific heat capacity of the conductor;
- m mass of the conductor;
- θ rise of the temperature above the temperature of the environment; h
- heat transfer coefficient of the surface of the conductor;
- A area of the surface of the conductor;
- t time.

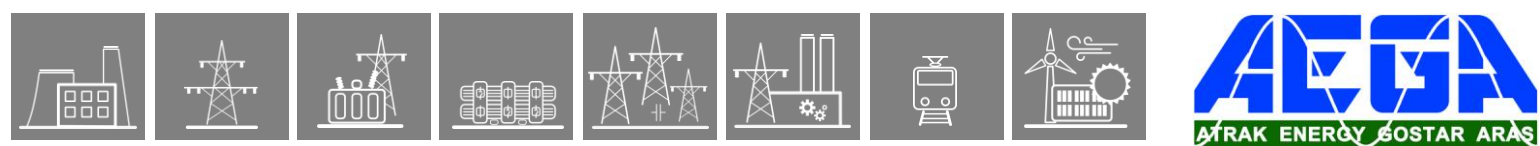

2.1.15.1.2. The temperature-time function for constant current

The solution of the thermal differential equation for constant current is the temperature as the function of time. (The mathematical derivation of this equation is described in a separate document.)

$$\Theta(t) = \frac{I^2 R}{hA} \left(1 - e^{-\frac{t}{T}} \right) + \Theta_0 e^{-\frac{t}{T}} \quad (2)$$

Remember that the calculation of the measurable temperature is as follows:

Temperature(t) = $\Theta(t)$ + Temp_ambient

where

Temp_ambient is the ambient temperature.

In that separate document it is proven that some more easily measurable parameters can be introduced instead of the aforementioned ones. Thus, the general form of equation (2) is:

$$H(t) = \frac{\Theta(t)}{\Theta_n} = \frac{I^2}{I_n^2} \left(1 - e^{-\frac{t}{T}} \right) + \frac{\Theta_0}{\Theta_n} e^{-\frac{t}{T}} \quad (3)$$

where:

$H(t)$ is the „thermal level” of the heated object, **this is the temperature as a percentage of the Θ_n reference temperature.** (This is a dimensionless quantity but it can also be expressed in a percentage form.)

Θ_0 is the starting temperature above the temperature of the environment

Θ_n is the reference temperature above the temperature of the environment, which can be measured in steady state, in case of a continuous I_n reference current.

I_n is the reference current (can be considered as the nominal current of the heated object). If it flows continuously, then the reference temperature can be measured in steady state.

2.1.15.1.3. Formulas for checking the thermal protection functions

Equation (3) offers a general formula to check the operation of the thermal protection using constant current.

The changes of temperature over time, (above the temperature of the environment), described by equation (3), are plotted in the diagram below. Parameter is the starting

temperature related to the reference temperature $\frac{\Theta_o}{\Theta_n}$

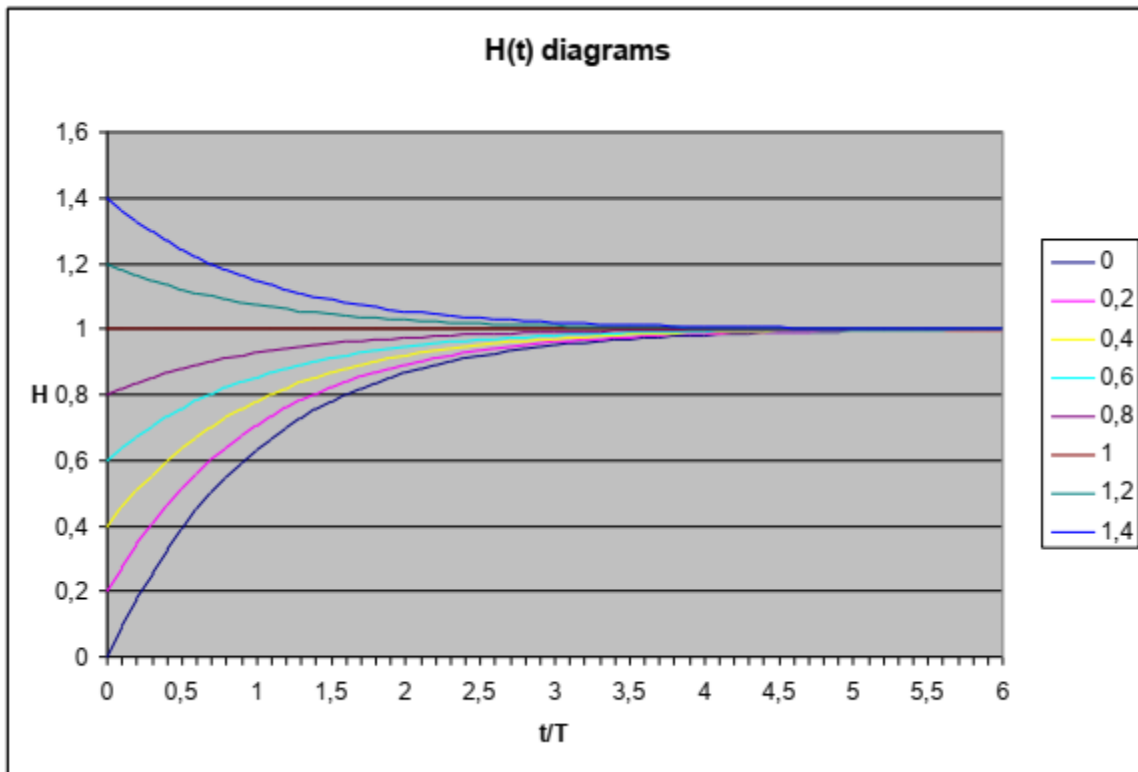

For further tests, the time needed to reach a specific temperature value can be calculated based on equation (3). The derived formula with relative quantities is:

$$\frac{t}{T} = \ln \left(\frac{\frac{\Theta_s - \Theta_o}{\Theta_n - \Theta_n}}{\frac{\Theta_s - \Theta_{set}}{\Theta_n - \Theta_n}} \right) \quad (4)$$

where:

$\Theta_s = \frac{I^2 \Theta_n}{I_n^2}$ is the steady state temperature in case of continuous I current,

Θ_{set} is the momentary temperature above the ambient temperature; the time to reach this is to be calculated,

Θ_o is the starting „overtemperature”,

Θ_n is the reference temperature above the temperature of the environment, which can be measured in steady state, in case of a continuous I_n reference current.

To be able to compare the current–time characteristics of the thermal protection with that of the inverse characteristics, formula (4) can be rearranged using currents and per unit quantities:

$$\frac{t}{T} = \ln \frac{\frac{I^2}{I_{set}^2} - \frac{I_0^2}{I_{set}^2}}{\frac{I^2}{I_{set}^2} - 1} \quad (5)$$

where:

I_0 is the continuous current that results Θ_0 steady state “overtemperature” at the beginning of the calculation,

I is the current that is applied to reach the steady state Θ_S “overtemperature”,

$$(\Theta_S = \frac{I^2 \Theta_n}{I_n^2}).$$

I_{set} would be the setting current of the equivalent „overcurrent” function.

The plots according to equation (5) can be seen below. They show how much time is left to reach the „trip temperature” in case of a continuous I (RMS) current. The parameter is the continuous I_0 current related to the I_n rated current, which generates the steady state starting temperature. The topmost curve is the „cold curve”.

The plots below clearly show that the thermal replica method “remembers” the starting temperature. If the starting temperature (I_0 pre-faulty steady state current) is increased, the time to trip at a fault current $I/I_{set} > 1$ automatically decreases.

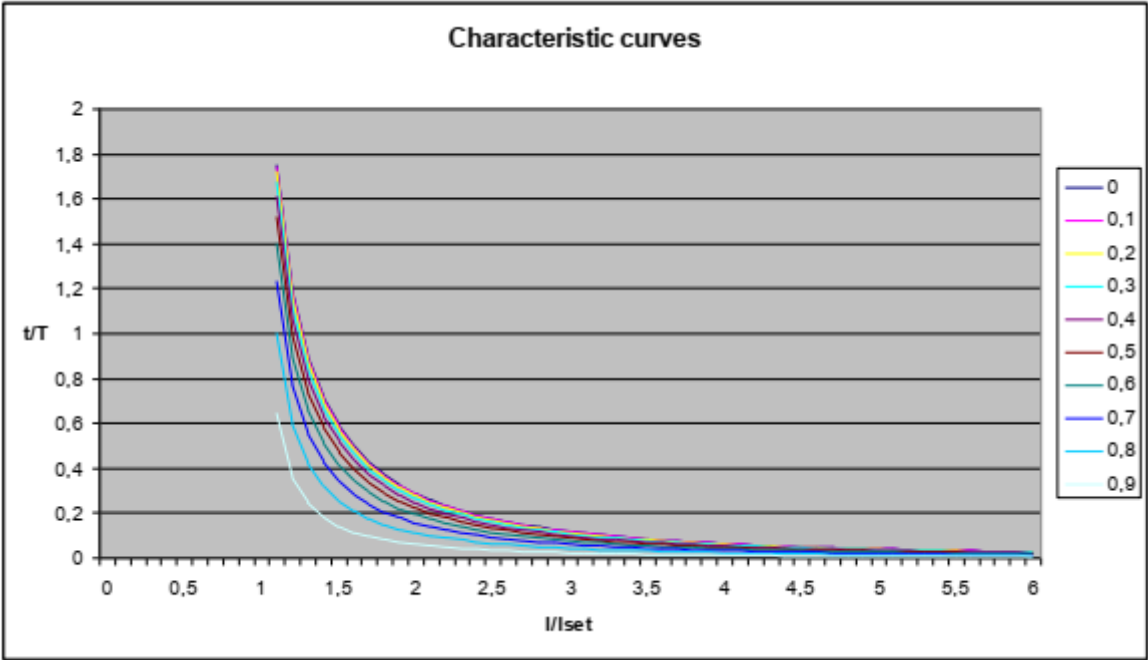

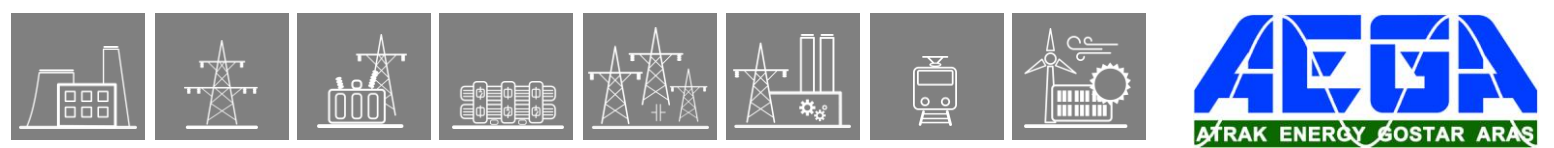

2.1.15.1.4. Numerical solution of the thermal differential equation

The formulas (2-5) above refer to a constant current and can be used to test the thermal protection. In reality, the RMS value of the current changes over time; consequently, differential equation (1) must be solved using a numerical method. The separate document explains the steps to obtain the calculation formula:

$$H_k = \frac{\Theta_k}{\Theta_n} = \left(1 - \frac{\Delta t}{T}\right) \frac{\Theta_{k-1}}{\Theta_n} + \frac{\Delta t}{T} \frac{I^2}{I_n^2} \quad (6)$$

where:

- Θ_k is the temperature (above the temperature of the environment) at the k-th calculation step;
- Θ_{k-1} is the temperature (above the temperature of the environment) one calculation step before.

(The line thermal protection is calculating the temperature based on the formula (6) above, the user of the thermal protection does not need to apply it.)

2.1.15.2. Structure of the line thermal protection

Fig.1-1 shows the structure of the line thermal protection (TTR49L) algorithm.

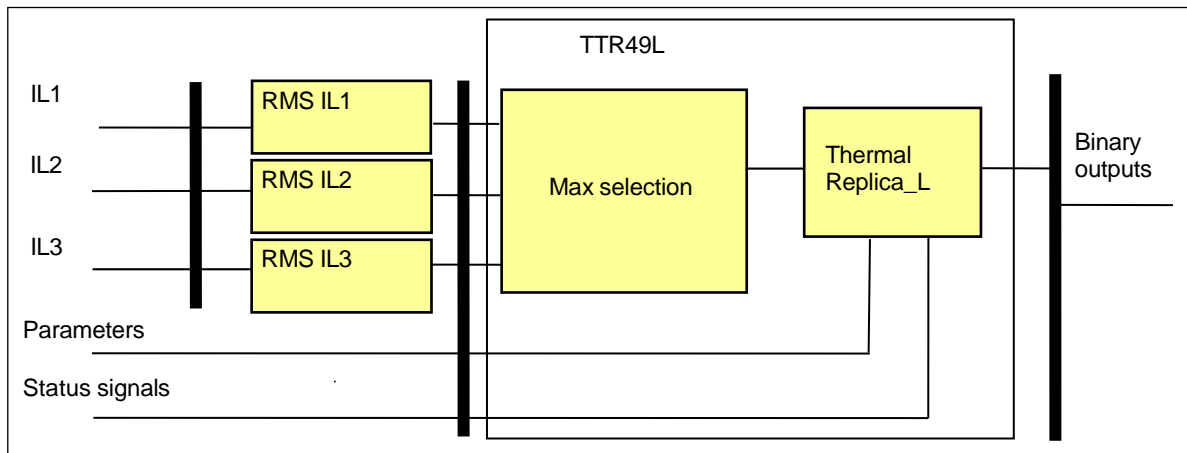

Figure 1-1 Structure of the line thermal protection algorithm

The **inputs** are the RMS values of three primary phase currents, parameters, status signals.

The **outputs** are the binary output status signals.

The **software modules** of the line thermal protection function:

RMS calculations

These modules calculate the RMS values of the phase currents individually. The sampling frequency of the calculations is 1 kHz; therefore, theoretically, the frequency components below 500Hz are considered correctly in the RMS values. This module is not part of the thermal function; it belongs to the preparatory phase.

Max selection

This module selects the maximal value of the RMS phase currents.

Thermal replica

This module solves the first order thermal differential equation using a simple step-by-step method and compares the calculated temperature to the values set by parameters.

The following description explains the details of the individual components.

2.1.15.3. RMS calculation (RMS)

These modules calculate the true RMS values of the phase currents individually. The sampling frequency of the calculations is 1 kHz; therefore, theoretically, the frequency components below 500Hz are considered correctly in the RMS values. This module is not part of the thermal function; it belongs to the preparatory phase.

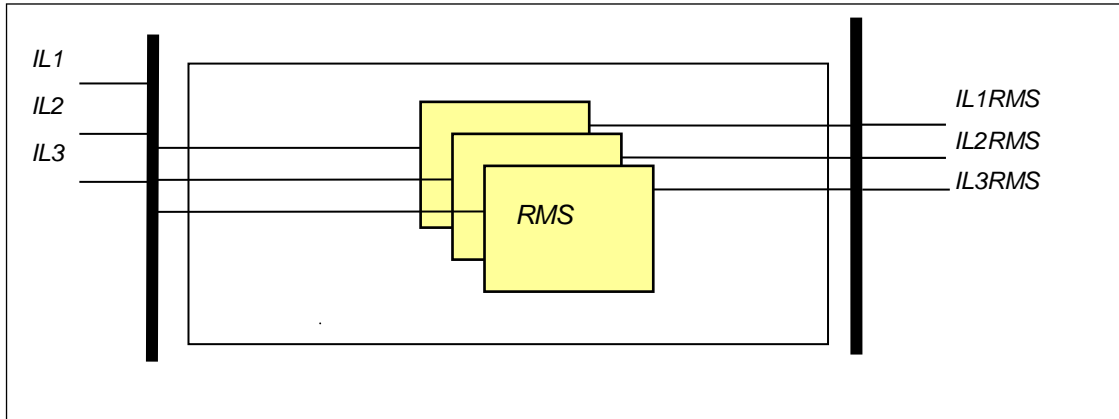

Figure 1-2 Principal scheme of the current RMS calculation

The **inputs** are the sampled values of the three phase currents (IL1, IL2, IL3)

The **outputs** are the RMS values of the analyzed currents (IL1RMS, IL2RMS, IL3RMS).

2.1.15.4. The maximum selection (Max selection)

This module selects the maximum of the three RMS values.

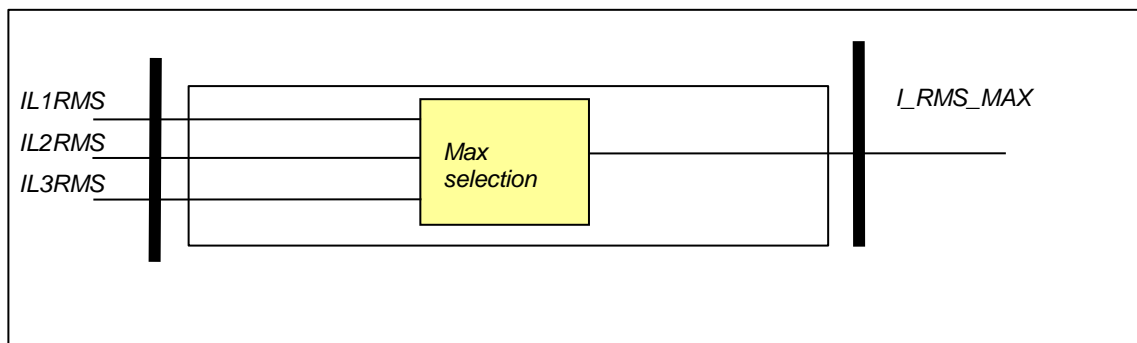
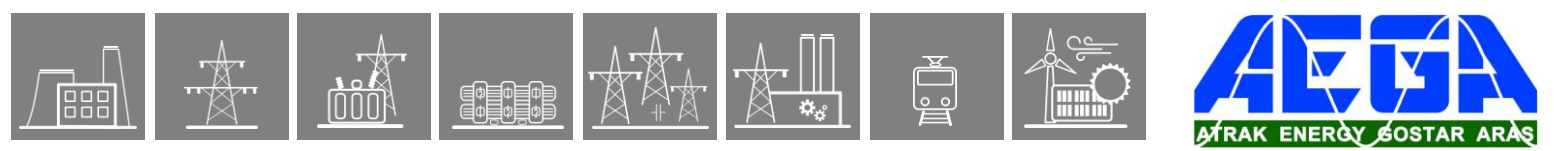

Figure 1-3 Principal scheme of the maximum selection

The **inputs** are the RMS values of the analyzed currents (IL1RMS, IL2RMS, IL3RMS). The

output is the selected maximum of the three RMS values.



2.1.15.5. The temperature calculation and decision (Thermal replic)

This module solves the first order thermal differential equation using a simple step-by-step method and compares the calculated temperature to the values set by parameters.

The **inputs** are

- The selected maximum of the three RMS values of the phase currents,
- The value proportional to the ambient temperature (this signal is optional, defined at parameter setting),
- Binary input status signals,

Parameters.

The **outputs** are the status signals. These indicate the generated trip command if the temperature is above the preset current value.

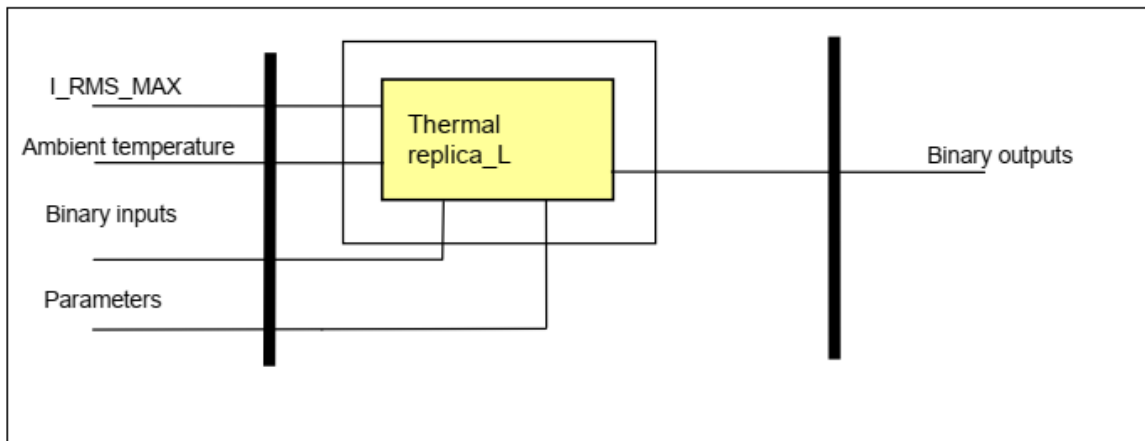
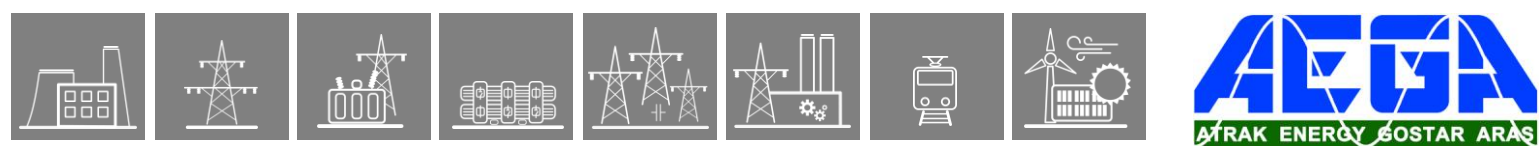

Figure 1-4 Principal scheme of the thermal replica calculation



Enumerated parameter

Parameter name	Title	Selection range	Default
Parameter for mode of operation			
TTR49L_Oper_EPar_	Operation	Off, Pulsed, Locked	Pulsed

Table 1-1 The enumerated parameters of the line thermal protection function

The meaning of the enumerated values is as follows:

- Off The function is switched off; no output status signals are generated;
- Pulsed The function generates a trip pulse if the calculated temperature exceeds the trip value
- Locked The function generates a trip signal if the calculated temperature exceeds the trip value. It resets only if the temperature cools below the “Unlock temperature”.

Integer parameters

Parameter name	Title	Unit	Min	Max	Step	Default
Alarm Temperature						
TTR49L_Alm_IPar_	Alarm Temperature	deg	60	200	1	80
Trip Temperature						
TTR49L_Trip_IPar_	Trip Temperature	deg	60	200	1	100
Rated Temperature						
TTR49L_Max_IPar_	Rated Temperature	deg	60	200	1	100
Base Temperature						
TTR49L_Ref_IPar_	Base Temperature	deg	0	40	1	25
Unlock Temperature						
TTR49L_Unl_IPar_	Unlock Temperature	deg	20	200	1	60
Ambient Temperature						
TTR49L_Amb_IPar_	Ambient Temperature	deg	0	40	1	25
Startup Term.						
TTR49L_Str_IPar	Startup Term	%	0	60	1	0
Rated Load Current						
TTR49L_Inom_IPar_	Rated Load Current	%	20	150	1	100
Time constant						
TTR49L_pT_IPar_	Time Constant	min	1	999	1	10

Table 1-2 The integer parameters of the line thermal protection function

Boolean parameter

Boolean parameter	Signal title	Selection range	Default
Parameter for ambient temperature sensor application (Special HW input module is required)			
TTR49L_Sens_BPar_	Temperature Sensor	No, Yes	No

Table 1-3 The Boolean parameter of the line thermal protection function

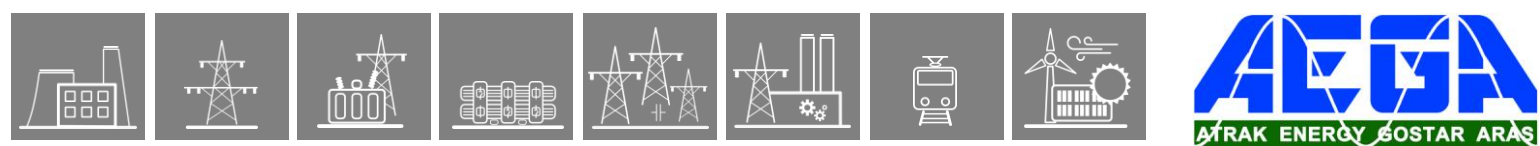

The **binary output status signals** of the line thermal protection function are shown in Table 1-4.

Binary output signals	Signal title	Explanation
TTR49L_Alm_Grl_	Alarm	Alarm signal of the line thermal protection function
TTR49L_GenTr_Grl_	General Trip	General trip signal of the line thermal protection function
TTR49L_Lock_Grl_	Reclose locked	Line reclose blocking signal of the line thermal protection function

Table 1-4 The binary output status signals of the line thermal protection function

Binary input status signals

The line thermal protection function has two binary input status signals. One of them serves to disable the function; the other one resets the accumulated heat. Resetting serves test purposes only, if the heating calculation needs to start at a clearly defined temperature. Using this signal, the testing engineer need not wait until the cooling reaches the required starting temperature of the subsequent heating test.

Both binary input status signals are defined by the user, applying the graphic equation editor.

The binary input status signals of the line thermal protection function are shown in Table 1-5.

Binary input status signals	Title	Explanation
TTR49L_BlK_GrO_	Block	Output status of a graphic equation defined by the user to disable the line thermal protection function.
TTR49L_Reset_GrO_	Reset	Output status of a graphic equation defined by the user to reset the accumulated heat and set the temperature to the defined value for the subsequent heating test procedure.

Table 1-5 The binary input signals of the line thermal protection function

On-line measured value

On-line measured value	Explanation
TTR49L_Temp_OLM_	The calculated temperature.

Table 1-6 The on-line measured value of the line thermal protection function

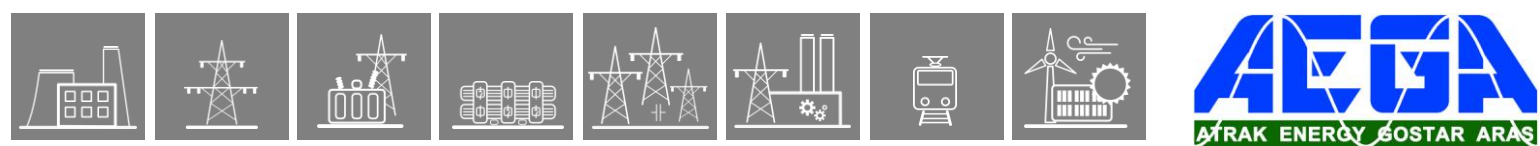

2.1.15.6. Technical summary

2.1.15.6.1. Technical data

Function	Accuracy
Operate time at $I > 1.2 \cdot I_{trip}$	$< 3\%$ or $< + 20\text{ ms}$

Table 1-7 Technical data of the line thermal protection function

2.1.15.6.2. The parameters

The parameters are summarized in Chapter 1.5.

2.1.15.6.3. The binary input status signals

The line thermal replica protection function has a binary input signal that serves the purpose of disabling the function. **The conditions of disabling are defined by the user, applying the graphic equation editor.**

The other binary input signal serves the purpose of resetting the stored temperature (supports testing the function). **The conditions of resetting the temperature are defined by the user, applying the graphic equation editor.**

Binary input signal	Explanation
TTR49L_BlK_GrO_	Output status of a graphic equation defined by the user to disable the line thermal protection function.
TTR49L_Reset_GrO_	Output status of a graphic equation defined by the user to reset the accumulated heat and set the temperature to the defined value for the subsequent heating test procedure.

Table 1-8 The binary input signal of the line thermal protection function

2.1.15.6.4. Binary output status signals

The **binary output status signals** of the restricted earth-fault protection function are listed in Table 1-9.

Binary output signals	Signal title	Explanation
TTR49L_Alm_GrI_	Alarm	Alarm signal of the line thermal protection function
TTR49L_GenTr_GrI_	General Trip	General trip signal of the line thermal protection function
TTR49L_Lock_GrI_	Reclose locked	Line reclose blocking signal of the line thermal protection function

Table 1-9 The binary output status signals of the line thermal protection function

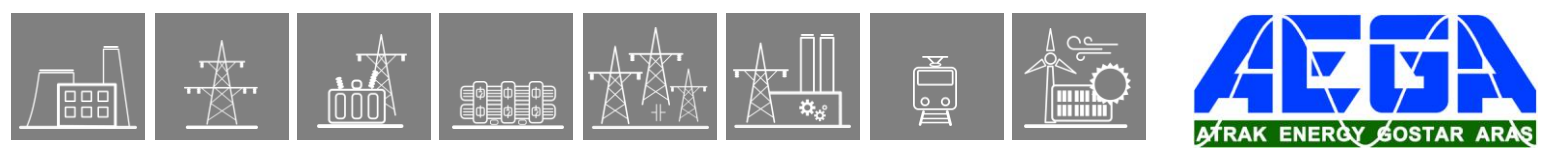

2.1.15.6.5. The function block

The function block of the line thermal protection function is shown in Figure 1-5. This block shows all binary input and output status signals that are applicable in the graphic equation editor.

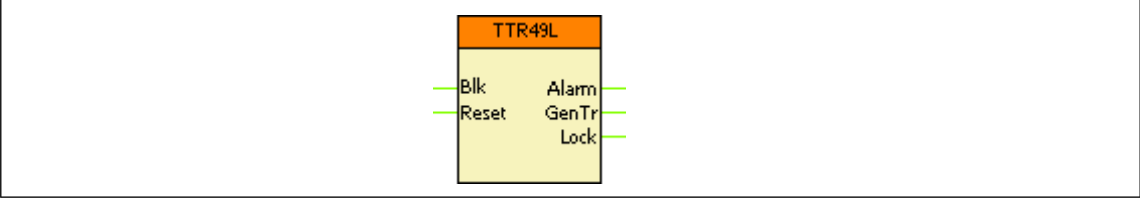
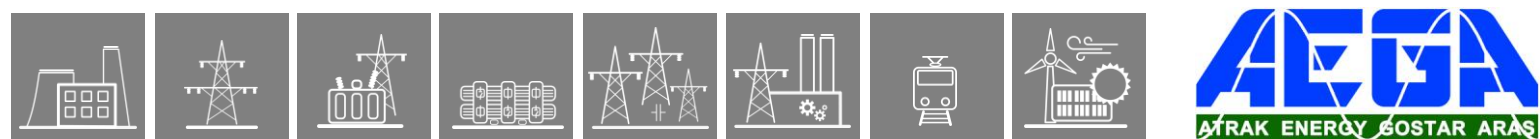

Figure 1-5 The function block of the line thermal protection function



2.1.16. Breaker failure protection

2.1.16.1. Application

After a protection function generates a trip command, it is expected that the circuit breaker opens and the fault current drops below the pre-defined normal level.

If not, then an additional trip command must be generated for all backup circuit breakers to clear the fault. At the same time, if required, a repeated trip command can be generated to the circuit breaker(s) which are expected to open.

The breaker failure protection function can be applied to perform this task.

In EuroProt+ product family two versions of breaker failure protection function can be applied:

“BRF50” – Breaker Failure:

This version of the breaker failure protection can be applied to perform the task to give command to the backup circuit breakers. It can be applied if only common-phase handling is sufficient, and phase selectivity is not required.

BRF50SP

“BRF50SP” - Single-pole Breaker Failure:

If repeated trip command (retrip) is needed besides the backup trip, this version of breaker failure protection function must be used.

Both versions of breaker failure protection function receive the trip requirements of the protective functions implemented in the device and combines the binary signals and parameters to the outputs of the device.

2.1.16.1.1. Mode of operation

The starting signal of the breaker failure protection function is usually the trip command of any other protection function. The user has the task to define these starting signals using the graphic equation editor as the “General Start” (BRF50_GenSt_GrO_), or if the operation of the individual phases is needed, then the start signals for the phases individually.

The phase start signals are: “Start L1” (BRF50_StL1_GrO_), “Start L2” (BRF50_StL2_GrO_) and “Start L3” (BRF50_StL3_GrO_).

Dedicated timers start at the rising edge of the start signals, one for the backup trip command and one for the repeated trip command, separately for operation in the individual phases. During the running time of the timers the function optionally monitors the currents, the closed state of the circuit breakers or both, according to the user’s choice. The selection is made using the enumerated parameter “Operation”:

- If this parameter setting is “Current”, the current limit values “Start Ph Current” and “Start Res Current” must be set correctly. The binary input indicating the status of the circuit breaker has no meaning.
- If this parameter setting is “Contact”, the current limit values “Start current Ph” and “Start current N” have no meaning. The binary input indicating the status of the circuit breaker must be programmed correctly using the graphic equation editor.
 - By using “BRF50” variant: the input variable to be programmed is: **BRF50_CBClosed_GrO_** (CB Closed),
 - By using “BRF50SP” variant: the input variables to be programmed are: **BRF50_CBCIL1_GrO_** (CB closed L1), **BRF50_CBCIL2_GrO_** (CB closed L2) and **BRF50_CBCIL3_GrO_** (CB closed L3).
- If this parameter setting is “Current/Contact”, the current parameters and the status signal must be set correctly. The breaker failure protection function resets only if all conditions for faultless state are fulfilled.

BRF50SP

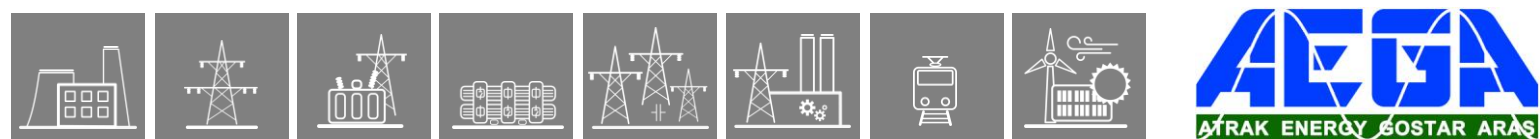

2.1.16.1.2. Operation principles

The decision logic module combines status signals, binary and enumerated parameters to generate the backup trip signal.

Binary status signals

The breaker failure protection function has binary input signals. **The conditions are defined by the user, applying the graphic equation editor.**

The **binary input status signals** of the breaker failure protection function are listed in Table 1-1.

Table 1-1 The binary input status signals of the decision logic

BINARY STATUS SIGNAL	TITLE	EXPLANATION
BRF50_ Blk _GrO_	Block	Blocking of the breaker failure protection function
BRF50_ CBClosed _GrO_	CB closed	Signal indicating the closed state of the circuit breaker
<i>BRF50SP_ CBCIL1_GrO_</i>	<i>CB closed L1</i>	<i>Signal indicating the closed state of the circuit breaker in phase L1</i>
<i>BRF50SP_ CBCIL2_GrO_</i>	<i>CB closed L2</i>	<i>Signal indicating the closed state of the circuit breaker in phase L2</i>
<i>BRF50SP_ CBCIL3_GrO_</i>	<i>CB closed L3</i>	<i>Signal indicating the closed state of the circuit breaker in phase L3</i>
BRF50_ GenSt _GrO_	General Start	General starting signal
<i>BRF50SP_ StL1_GrO_</i>	<i>Start L1</i>	<i>Starting signal in phase L1</i>
<i>BRF50SP_ StL2_GrO_</i>	<i>Start L2</i>	<i>Starting signal in phase L2</i>
<i>BRF50SP_ StL3_GrO_</i>	<i>Start L3</i>	<i>Starting signal in phase L3</i>
BRF50_ IoSt _GrO_	Start Io	Starting signal for the residual current
Internal signal:	IL1>	Current in phase L1 is above the preset parameter value
Internal signal:	IL2>	Current in phase L2 is above the preset parameter value
Internal signal:	IL3>	Current in phase L3 is above the preset parameter value
Internal signal:	Io>	Current 3Io is above the preset parameter value
Enumerated parameter	Current/Contact	The monitored condition is current, contact or both

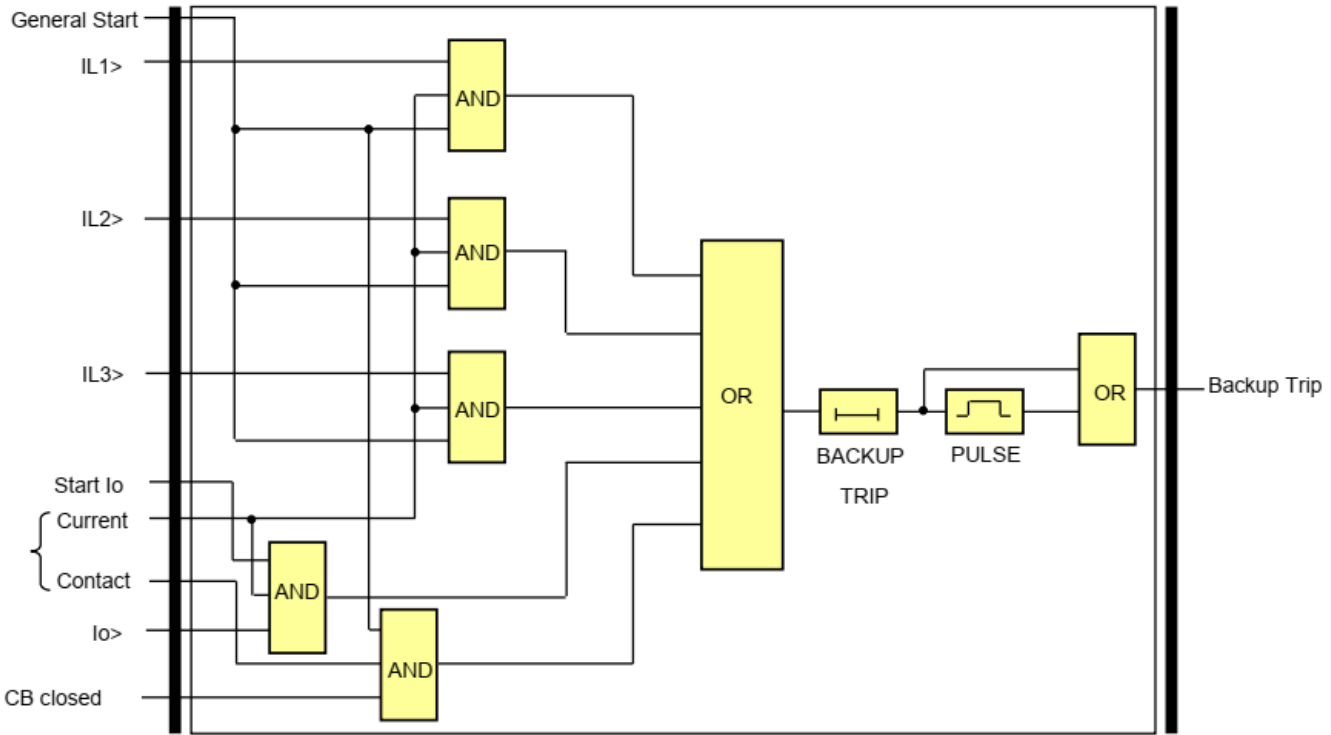

Figure 1-1 The logic scheme of the decision logic of “BRF50” variant

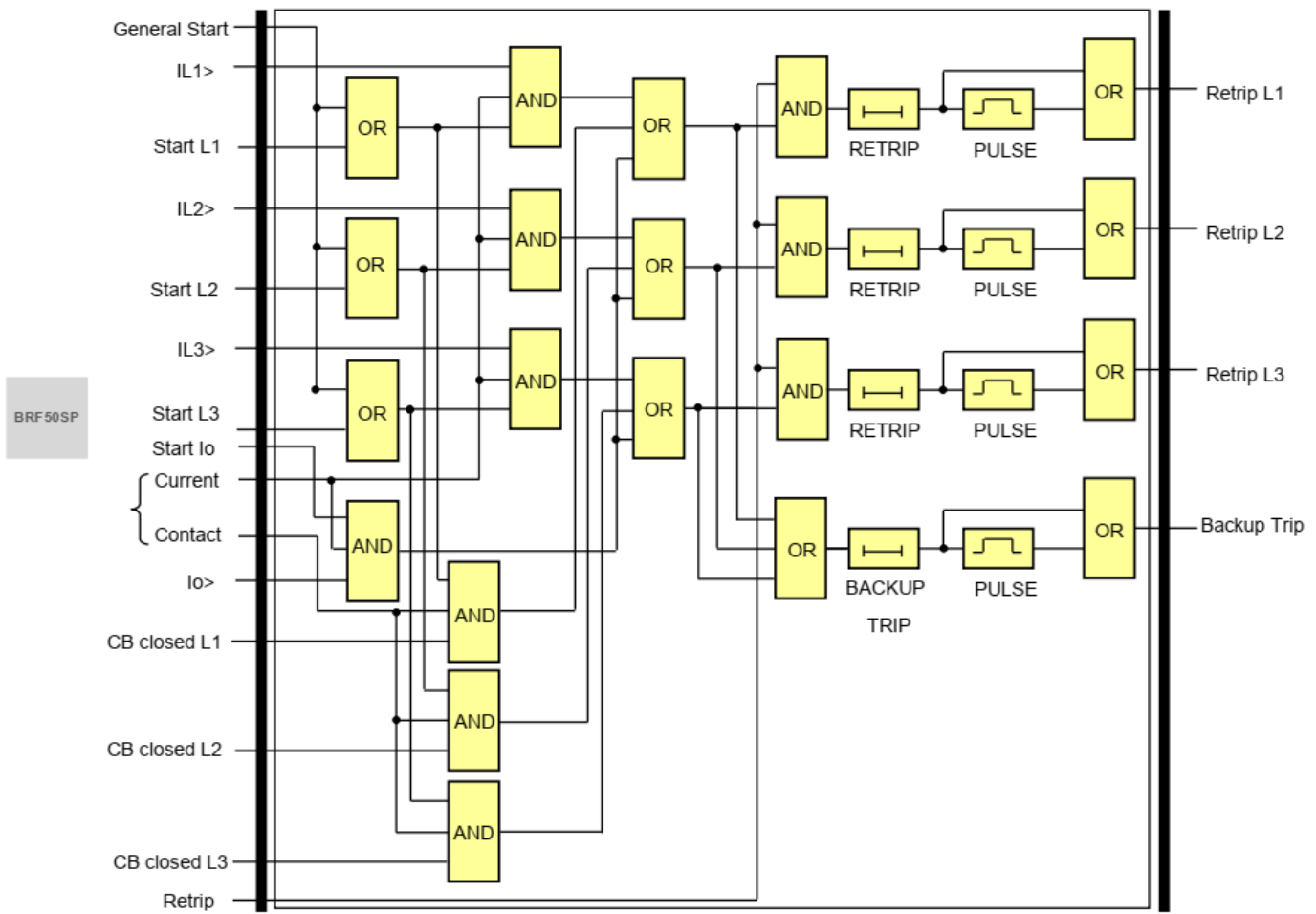
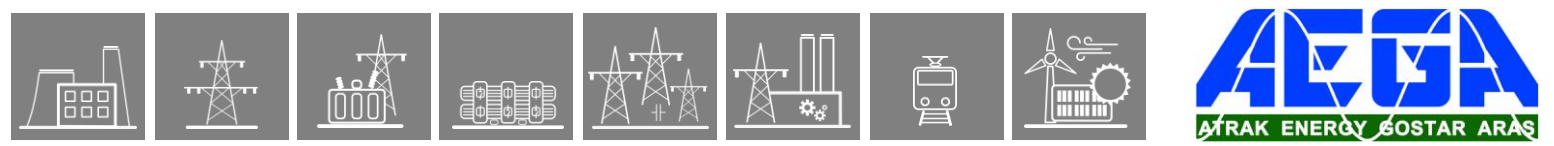

Figure 1-2 The logic scheme of the decision logic of “BRF50SP” variant



The **binary output status signals** of the breaker failure protection function is detailed in Table 1-2.

Table 1-2 The binary output status signal of the decision logic

BRF50SP

BINARY STATUS SIGNAL	TITLE	EXPLANATION
BRF50_BuTr_Grl_	Backup Trip	Trip command generated for the backup circuit breakers
BRF50_TrL1_Grl_	Retrip L1	Repeated trip command in phase L1
BRF50_TrL2_Grl_	Retrip L2	Repeated trip command in phase L2
BRF50_TrL3_Grl_	Retrip L3	Repeated trip command in phase L3

2.1.16.2. Breaker failure protection function overview

The graphic appearance of the variants the breaker failure protection function blocks are shown below. The blocks show all binary input and output status signals which are applicable in the graphic equation editor.

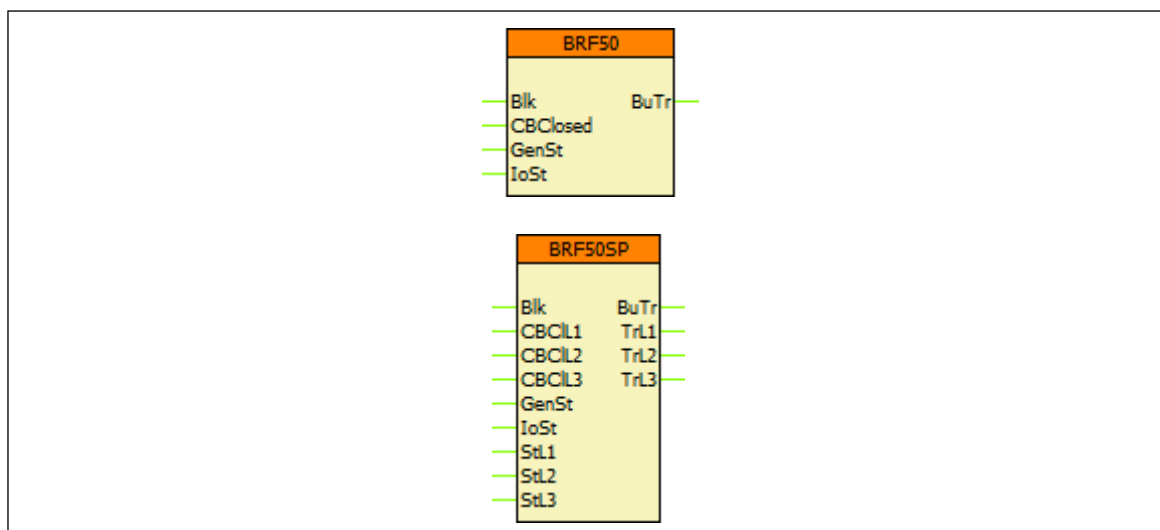

Figure 2-1 Graphic appearance of the variants of the breaker failure protection function block

2.1.16.2.1. Settings

2.1.16.2.1.1. Parameters

The available parameters are listed below in order of their appearance in the *parameters* menu. If the setting range of a parameter should be extended, contact Protecta Support.

Table 2-1 Parameters of the breaker failure protection function

	TITLE	DIM	RANGE	STEP	DEFAULT	EXPLANATION
	Operation	-	Off, Current, Contact, Current/Contact	-	Off	Enabling the function
BRF50SP	Retrip	-	Off, On	-	Off	Enabling the retrip function
	Start Ph Current	%	20 – 200	1	30	Phase current setting
	Start Res Current	%	10 – 200	1	20	Residual current setting
BRF50SP	Retrip Time Delay	msec	0 – 1000	1	100	Time delay for retrip command generation
	Backup Time Delay	msec	100 – 60000	1	1000	Time delay for trip command generation for the backup circuit breaker(s)
	Pulse Duration	msec	0 – 60000	1	100	Trip command impulse duration

2.1.16.2.2. Function I/O

This section describes briefly the analogue and digital inputs and outputs of the function block.

2.1.16.2.2.1. Analogue inputs

The function uses the sampled values of a current input. This is defined in the configuration.

2.1.16.2.2.2. Binary input signals (graphed output statuses)

The conditions of the binary inputs are defined by the user, applying the graphic equation editor (*Logic Editor*). Parts written in **bold** are seen on the left side function block in the Logic editor.

Table 2-2 The binary input signals of the breaker failure protection functions

BINARY STATUS SIGNAL	TITLE	EXPLANATION
BRF50_ Bik _GrO_	Block	Blocking of the breaker failure protection function
BRF50_ CBClosed _GrO_	CB closed	Signal indicating the closed state of the circuit breaker
<i>BRF50SP_ CBCIL1_GrO_</i>	<i>CB closed L1</i>	<i>Signal indicating the closed state of the circuit breaker in phase L1</i>
<i>BRF50SP_ CBCIL2_GrO_</i>	<i>CB closed L2</i>	<i>Signal indicating the closed state of the circuit breaker in phase L2</i>
<i>BRF50SP_ CBCIL3_GrO_</i>	<i>CB closed L3</i>	<i>Signal indicating the closed state of the circuit breaker in phase L3</i>
BRF50_ GenSt _GrO_	General Start	General starting signal
<i>BRF50SP_ StL1_GrO_</i>	<i>Start L1</i>	<i>Starting signal in phase L1</i>
<i>BRF50SP_ StL2_GrO_</i>	<i>Start L2</i>	<i>Starting signal in phase L2</i>
<i>BRF50SP_ StL3_GrO_</i>	<i>Start L3</i>	<i>Starting signal in phase L3</i>
BRF50_ IoSt _GrO_	Start Io	Starting signal for the residual current

2.1.16.2.2.3. Binary output signals (graphed input statuses)

These signals can be used in EuroCAP to assign to LED, user LCD object etc. Parts written in **bold** are seen on the right side of the function block in the *Logic Editor*.

Table 2-3 The binary output signals of the breaker failure protection function

BINARY STATUS SIGNAL	TITLE	EXPLANATION
BRF50_ BuTr _GrI_	Backup Trip	Trip command generated for the backup circuit breakers
<i>BRF50_ TrL1_GrI_</i>	<i>Retrip L1</i>	<i>Repeated trip command in phase L1</i>
<i>BRF50_ TrL2_GrI_</i>	<i>Retrip L2</i>	<i>Repeated trip command in phase L2</i>
<i>BRF50_ TrL3_GrI_</i>	<i>Retrip L3</i>	<i>Repeated trip command in phase L3</i>

2.1.16.2.2.4. Online data

Visible values on the *online data* page.

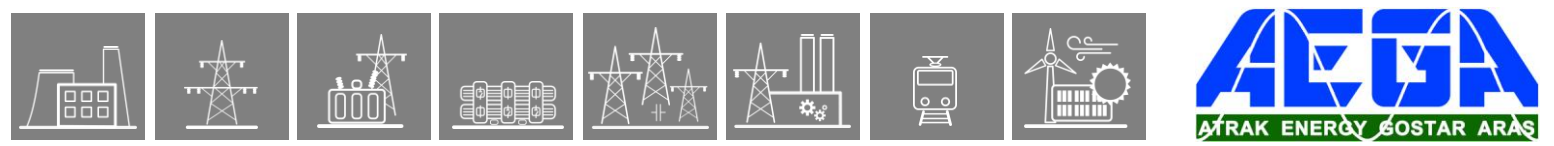

Table 2-4 Online displayed data of the breaker failure protection function

	SIGNAL TITLE	DIMENSION	EXPLANATION
	Backup Trip	-	Trip command generated for the backup circuit breakers
BRF50SP	<i>Retrip L1</i>	-	<i>Repeated trip command in phase L1</i>
	<i>Retrip L2</i>	-	<i>Repeated trip command in phase L2</i>
	<i>Retrip L3</i>	-	<i>Repeated trip command in phase L3</i>

2.1.16.2.2.5. Events

The following events are generated in the event list, as well as sent to the SCADA according to the configuration.

Table 2-5 Generated events of the breaker failure protection function

EVENT	VALUE	EXPLANATION
Backup Trip	off, on	Backup trip command of the function
<i>Retrip L1</i>	off, on	<i>Repeated trip command in phase L1</i>
<i>Retrip L2</i>	off, on	<i>Repeated trip command in phase L2</i>
<i>Retrip L3</i>	off, on	<i>Repeated trip command in phase L3</i>

BRF50SP

2.1.16.2.3. Technical data

Table 2-6 Technical data of the breaker failure protection function

FUNCTION	VALUE	ACCURACY
Pick-up starting accuracy		< 2 %
Operate time accuracy		±5% or ±15 ms, whichever is greater
Retrip time	approx. 15 ms	
Reset ratio	0.9	
Current reset time	16 – 25 ms	

2.1.16.2.4. Notes for testing

Note that the time delay parameter incorporates the algorithm time as well, so the time delay **does not mean the time difference between the appearance of the start and trip signals** of the function. In other words: it is not the delay between the detection of the fault and the trip that follows it. This should be taken into consideration when checking the disturbance records.

Instead the time delay parameter defines the elapsed time from the appearance of the faulty state to the trip. Because of this, while testing, the delay measurement should start *from the moment of the fault injection* until the trip signal.

2.1.17. Three-phase instantaneous Overcurrent Protection

2.1.17.1. Application

The instantaneous overcurrent protection function operates according to instantaneous characteristics, using the three sampled phase currents. The setting value is a parameter, and it can be doubled by graphic programming of the dedicated input binary signal.

The basic calculation can be based on peak value selection or on Fourier basic harmonic calculation, according to the parameter setting. When Fourier calculation is selected then the accuracy of the operation is high, the operation time however is above one period of the network frequency. If the operation is based on peak values, then fast sub-cycle operation can be expected, but the transient overreach can be high.

2.1.17.1.1. Operating Characteristics

$$t(I) = t_{OP} \text{ when } I > I_s$$

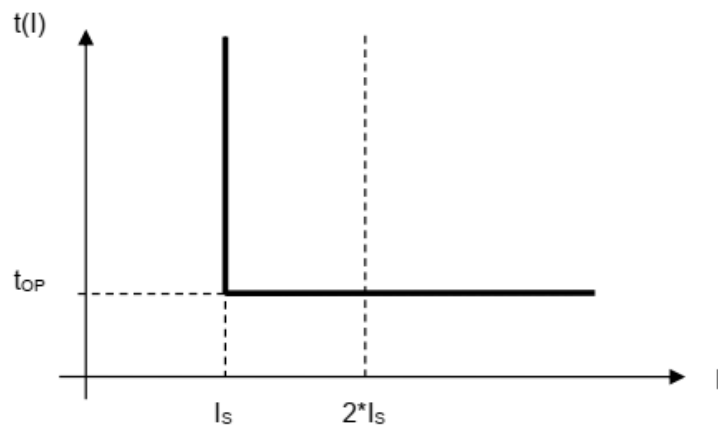

Figure 1-1 Overcurrent independent time characteristic

where:

- t_{OP} (sec.) theoretical operating time if $I > I_{Gs}$ (without additional time delay),
- I measured value of the characteristic quantity, peak values or Fourier base harmonic of the phase currents,
- I_s setting value of the characteristic quantity (*Start current*)

2.1.17.1.2. Structure of the Protection Algorithm

Figure 1-2 shows the structure of the instantaneous overcurrent protection (IOC50) algorithm.

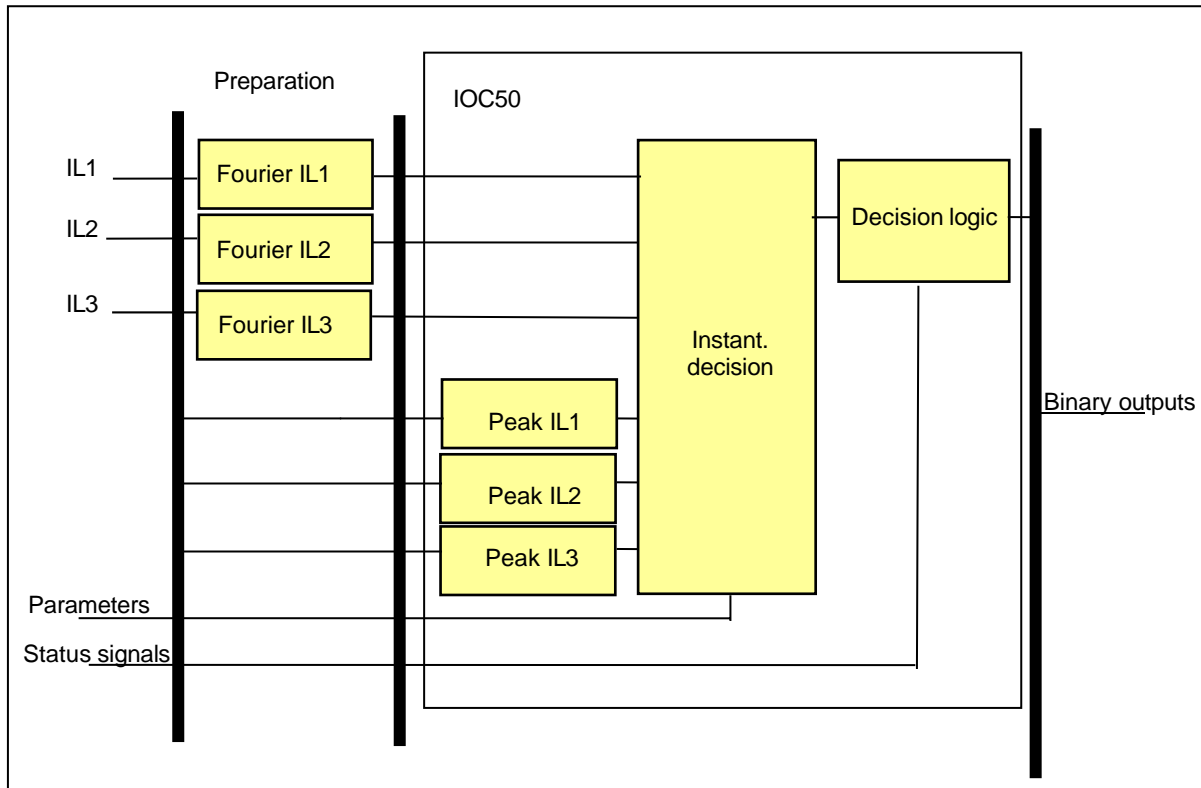

Figure 1-2 Structure of the instantaneous overcurrent protection algorithm

The **inputs** are

- the sampled values of three phase currents,
- the RMS values of the fundamental Fourier component of three phase currents,
- parameters,
- status signals.

The **outputs** are

- the binary output status signals.

The **software modules** of the three-phase instantaneous overcurrent protection function are:

Fourier calculations

These modules calculate the RMS values of the fundamental Fourier component of three phase currents individually (not part of the IOC50 function).

Peak selection

These modules select the peak values of the phase currents individually.

Instantaneous decision

This module compares the peak value or the Fourier basic harmonic components of the phase currents with the setting value.

Decision logic

The decision logic modules generate the trip command of the function.

2.1.17.1.3. The Fourier Calculation (Fourier)

The following description explains the details of the individual components.

These modules calculate the RMS values of the fundamental Fourier component of the three phase currents individually. They are not part of the IOC50 function; they belong to the preparatory phase.

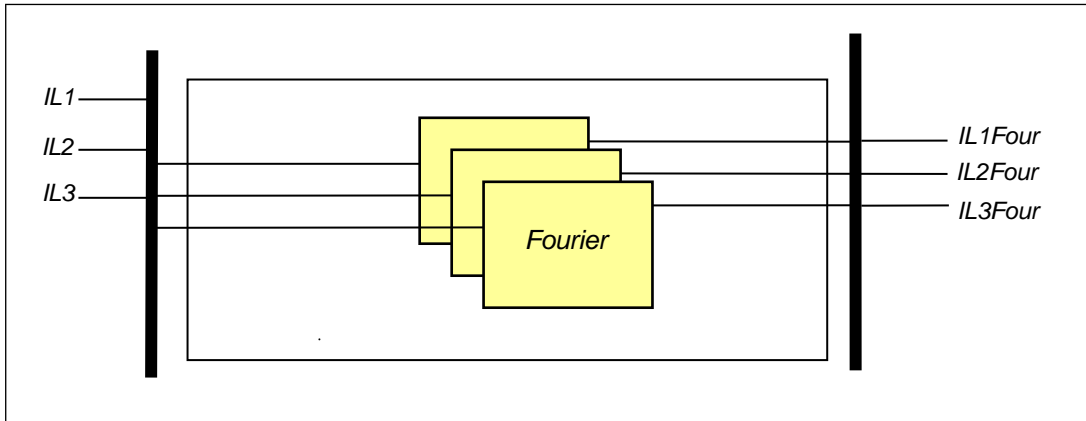

Figure 1-3 Principal scheme of the Fourier calculation

The **inputs** are the sampled values of the three phase currents (IL1, IL2, IL3).

The **outputs** are the RMS values of the fundamental Fourier component of three phase currents (IL1Four, IL2Four, IL3Four).

2.1.17.1.4. The Peak Selection (Peak selection)

These modules select the peak values of the phase currents individually.

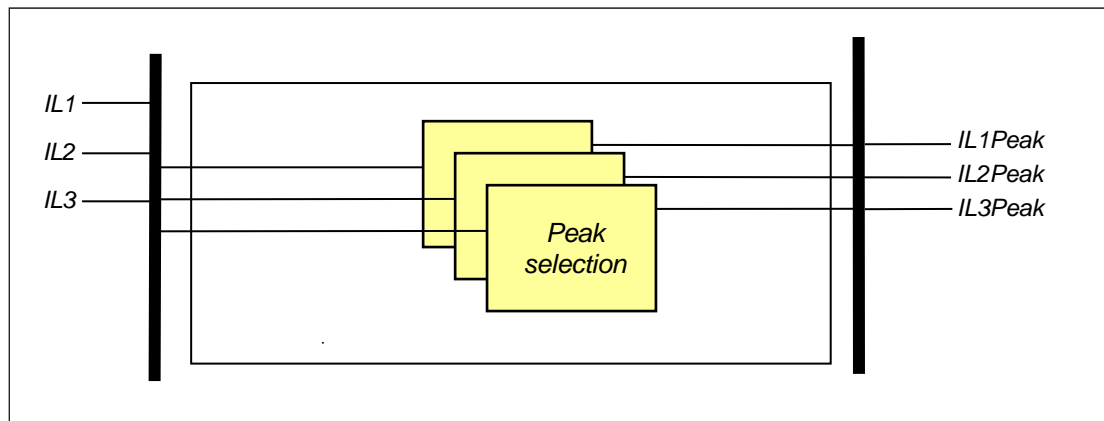

Figure 1-4 Principal scheme of the peak selection

The **inputs** are the sampled values of the three phase currents (IL1, IL2, IL3).

The **outputs** are the peak values of the analyzed currents (IL1Peak, IL2 Peak, IL3 Peak).

2.1.17.1.5. The Instantaneous Decision (Instantaneous decision)

This module generates trip commands for the phases without additional time delay based on the Fourier components of the phase currents or based on the peak values, if the detected values are above the current setting value.

The **inputs** are the RMS values of the fundamental Fourier component of three phase currents (IL1Four, IL2Four, IL3Four), the peak values (IL1Peak, IL2 Peak, IL3 Peak), parameters and status signals.

The **outputs** are the status signals of the three phases individually. These indicate the generated trip commands if the currents are above the current setting value.

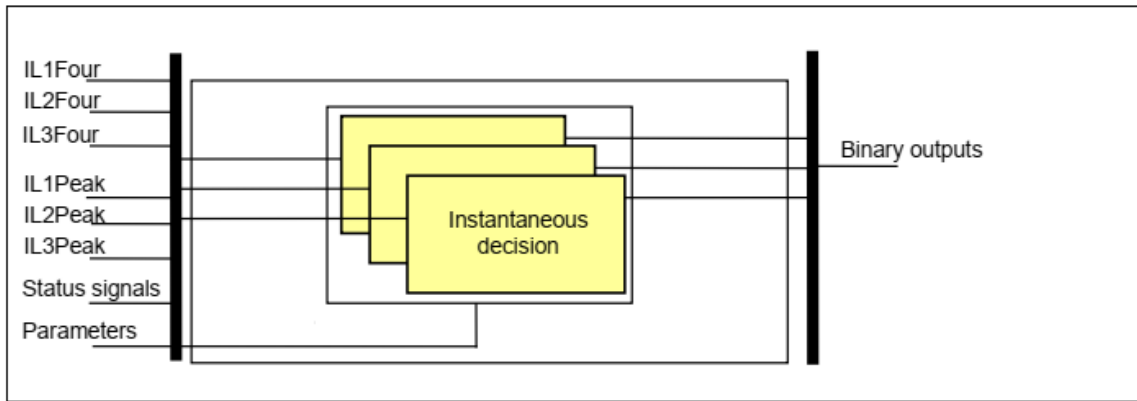

Figure 1-5 Principal scheme of the instantaneous characteristic calculation

Enumerated parameters

Table 1-1 The enumerated parameters of the instantaneous OC protection function

TITLE	DIM	RANGE	STEP	DEFAULT	EXPLANATION
Operation	-	Off, Peak value, Fundamental value	-	Off	Parameter for enabling the function and selection type.

Integer parameters

Table 1-2 The integer parameter of the instantaneous OC protection function

TITLE	DIM	RANGE	STEP	DEFAULT	EXPLANATION
Start Current	%	20 – 3000	1	200	Start setting of the function. If the current exceeds this value, the function picks up and trips after the minimum operation time of the relay (t_{OP}).

Binary status signals

The decision block of the instantaneous overcurrent protection function has binary input signals, which serve the purpose of blocking the function and doubling the setting value of the function.

The conditions are defined by the user, applying the graphic equation editor.

Table 1-3 The binary input signals for the decision block of the IOC protection function

BINARY STATUS SIGNAL	SIGNAL TITLE	EXPLANATION
IOC50_Blk_GrO_	Block	Input for disabling the function
IOC50_Double_GrO_	Double	Input used to double the value of the parameter "Start Current".

The **binary output status signals** of the three-phase instantaneous overcurrent protection function are listed in Table 1-4 below.

Table 1-4 The binary output status signals of the IOC protection function

BINARY OUTPUT SIGNAL	SIGNAL TITLE	EXPLANATION
IOC50_TrL1_GrI_	Trip L1	Trip command of the function in phase L1
IOC50_TrL2_GrI_	Trip L2	Trip command of the function in phase L2
IOC50_TrL3_GrI_	Trip L3	Trip command of the function in phase L3

2.1.17.1.6. The Decision Logic (Decision logic)

The decision logic module combines the status signals to generate the general trip command of the function.

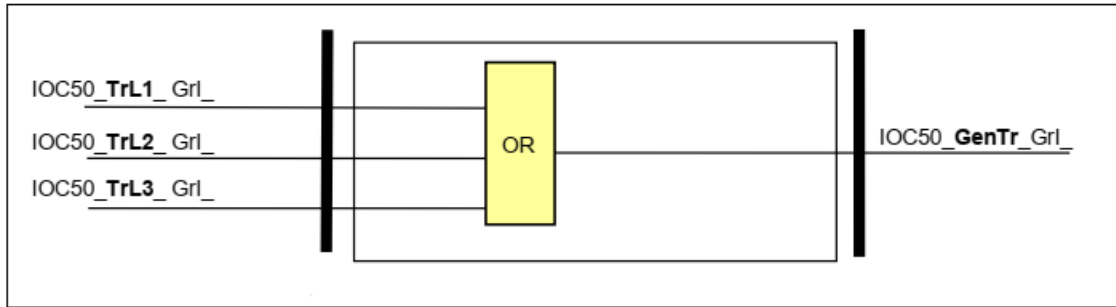

Figure 1-6 The logic scheme of the instantaneous overcurrent protection function

Table 1-5 The binary input status signals of the decision logic

BINARY INPUT SIGNAL	SIGNAL TITLE	EXPLANATION
IOC50_TrL1_Grl_	Trip L1	Trip command of the function in phase L1
IOC50_TrL2_Grl_	Trip L2	Trip command of the function in phase L2
IOC50_TrL3_Grl_	Trip L3	Trip command of the function in phase L3

Table 1-6 The binary output status signal of the decision logic

BINARY OUTPUT SIGNAL	SIGNAL TITLE	EXPLANATION
IOC50_GenTr_Grl_	General Trip	General trip command of the function

2.1.17.2.3-Phase Instantaneous OC Function Overview

The graphic appearance of the 3-phase instantaneous overcurrent protection function block is shown in Figure 2-1. This block shows all binary input and output status signals that are applicable in the graphic equation editor.

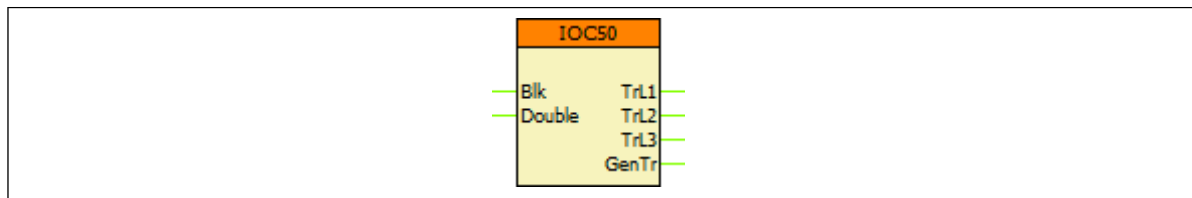

Figure 2-1 The function block of the 3-phase instantaneous overcurrent protection

2.1.17.2.1. Settings

2.1.17.2.1.1. Parameters

The available parameters are listed below in order of their appearance in the *parameters* menu. If the setting range of a parameter should be extended, contact Protecta Support.

Table 2-1 Parameters of the 3-phase instantaneous overcurrent protection function

TITLE	DIM	RANGE	STEP	DEFAULT	EXPLANATION
Operation	-	Off, Peak value, Fundamental value	-	Off	Parameter for enabling the function and selection type.
Start Current	%	20 – 3000	1	200	Start setting of the function. If the current exceeds this value, the function picks up and trips after the minimum operation time of the relay (t_{OP}).

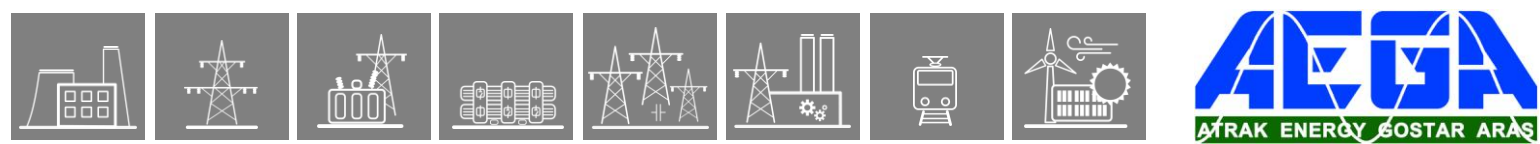

2.1.17.2.2. Function I/O

This section briefly describes the analogue and digital inputs and outputs of the function block.

2.1.17.2.2.1. Analogue inputs

The analogue inputs are the RMS values of the fundamental Fourier component of the three phase currents.

2.1.17.2.2.2. Binary input signals (graphed output statuses)

The conditions of the binary inputs are defined by the user, applying the graphic equation editor (*Logic Editor*). Parts written in **bold** are seen on the left side of the function block in the Logic editor.

Table 2-2 The binary input signals of the 3ph IOC function

BINARY INPUT SIGNAL	SIGNAL TITLE	EXPLANATION
IOC50_ Blk _GrO_	Block	Input for disabling the function
IOC50_ Double _GrO_	Double	Input used to double the value of the parameter "Start Current".

2.1.17.2.2.3. Binary output signals (graphed input statuses)

These signals can be used in EuroCAP to assign to LED, user LCD object etc. Parts written in **bold** are seen on the right side of the function block in the *Logic Editor*.

Table 2-3 The binary output signals of the 3ph IOC function

BINARY OUTPUT SIGNAL	SIGNAL TITLE	EXPLANATION
IOC50_ TrL1 _GrI_	Trip L1	Trip command of the function in phase L1
IOC50_ TrL2 _GrI_	Trip L2	Trip command of the function in phase L2
IOC50_ TrL3 _GrI_	Trip L3	Trip command of the function in phase L3
IOC50_ GenTr _GrI_	General Trip	Trip command of the function in at least one of the three phases

2.1.17.2.2.4. Online data

The following values are visible in the *online data* page.

Table 2-4 Online data of the 3ph IOC function

SIGNAL TITLE	DIMENSION	EXPLANATION
Trip L1	-	Trip command of the function in phase L1
Trip L2	-	Trip command of the function in phase L2
Trip L3	-	Trip command of the function in phase L3
General Trip	-	Trip command of the function in at least one of the three phases

2.1.17.2.2.5. Events

The following events are generated in the event list, as well as sent to the SCADA according to the configuration.

Table 2-5 Generatable events of the 3ph IOC function

EVENT	VALUE	EXPLANATION
Trip L1	off, on	Trip command of the function in phase L1
Trip L2	off, on	Trip command of the function in phase L2
Trip L3	off, on	Trip command of the function in phase L3
General Trip	off, on	Trip command of the function in at least one of the three phases

2.1.17.2.3. Technical Data

Table 2-6 Technical data of the 3-phase IOC protection function

FUNCTION	VALUE	ACCURACY
<i>Using peak value calculation</i>		
Operating characteristic	Instantaneous	< 6%
Reset ratio	0.85	
Operate time at 2*Is	< 15 ms	
Reset time*	< 40 ms	
Transient overreach	90%	
<i>Using Fourier fundamental harmonic calculation</i>		
Operating characteristic	Instantaneous	< 2%
Reset ratio	0.85	
Operate time at 2*Is	< 25 ms	
Reset time*	< 60 ms	
Transient overreach	15%	

* Measured with signal contacts

2.1.17.2.4. Notes for Testing

Normally in the EuroProt+ devices the trip contacts are assigned to the Trip Logic function block, and not to the protection function blocks. Because of this, the testing personnel must make sure that the Trip Logic is switched on ('Operation' parameter is set to other than 'Off') before starting the tests, otherwise there will be no physical trip on the relay.

Being an instantaneous function, its connection to the Trip Logic function is done in the Fast Equations (by default) and not in the Logic Editor (usually, there are comments inserted in the Logic Editor if such connections exist). This can be checked in EuroCAP.

The analogue sources can be changed by the user (i.e. if there are multiple CT modules in a device, it might be possible to assign the measurements of either CT module to the function's inputs). This can be checked in the function block properties in EuroCAP.

2.1.18.1.3. The Fourier Calculation (Fourier)

This module calculates the basic Fourier current components of the residual current. It is not part of the residual instantaneous overcurrent protection function; it belongs to the preparatory phase.

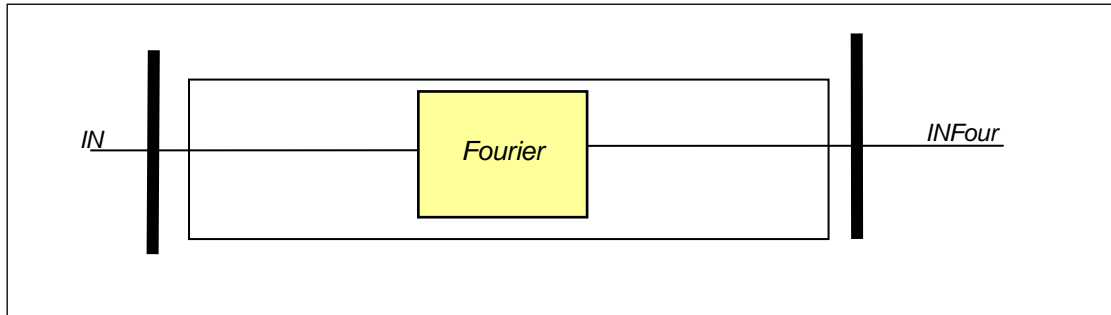

Figure 1-3 Principal scheme of the Fourier calculation

The **inputs** are the sampled values of the residual current (IN).

The **output** is the RMS value of the fundamental Fourier component of the residual current (INFour).

2.1.18.1.4. The Peak Selection (Peak selection)

This module selects the peak values of the residual current.

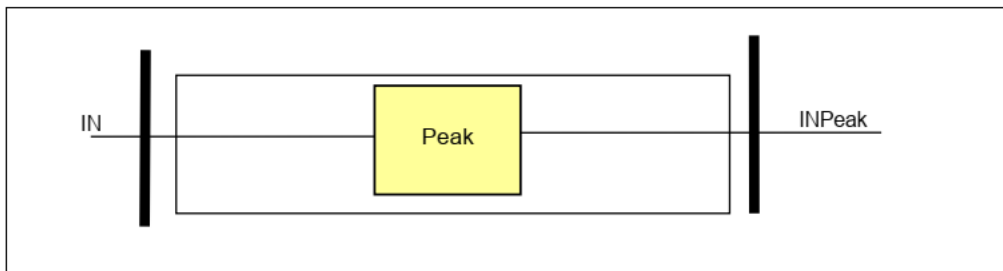
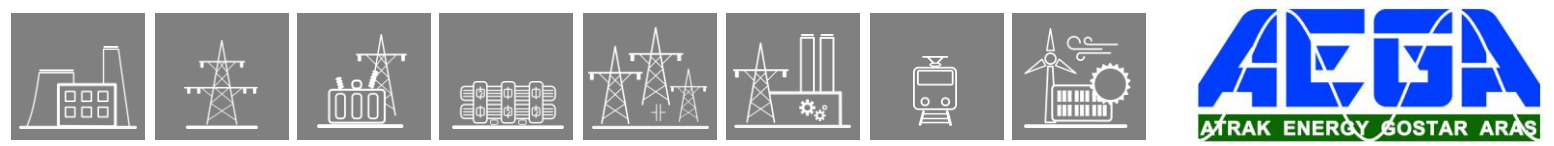

Figure 1-4 Principal scheme of the peak selection

The **inputs** are the sampled values of the residual current (IN).

The **outputs** are the peak values of the analyzed current (INPeak).



2.1.18.1.5. The Instantaneous Decision (Instantaneous decision)

This module generates an internal trip command without additional time delay based on the Fourier components of the residual current, or based on the peak values if the detected values are above the current setting value.

The **inputs** are the basic Fourier components of the residual current (INFour), the peak values (INPeak), parameters and status signals.

The **outputs** are the status signals. These indicate the generated internal trip command if the current is above the current setting value.

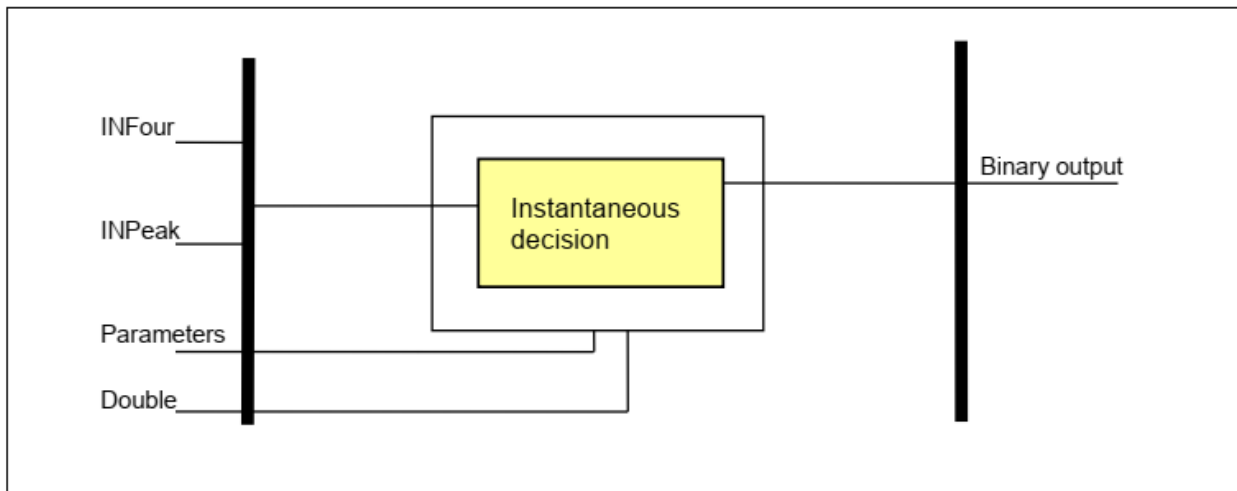

Figure 1-5 Principal scheme of the residual instantaneous characteristic calculation

Enumerated parameters

Table 1-1 The enumerated parameters of the residual IOC protection function

TITLE	DIM	RANGE	STEP	DEFAULT	EXPLANATION
Operation	-	Off, Peak value, Fundamental value	-	Off	Parameter for enabling the function and selection type.

Integer parameters

Table 1-2 The integer parameters of the residual IOC protection function

TITLE	DIM	RANGE	STEP	DEFAULT	EXPLANATION
Start Current	%	20 – 3000*	1	200	Setting value of the function.

Binary status signals

The decision block of the residual instantaneous overcurrent protection function has a binary input signal, which serves the purpose of doubling the setting value of the function. **The conditions are defined by the user, applying the graphic equation editor.**

Table 1-3 The binary input signals for the decision block of the residual IOC protection function

BINARY STATUS SIGNAL	SIGNAL TITLE	EXPLANATION
IOC50N_Double_GrO_	Double	Input used to double the value of the parameter "Start Current".

The **binary output status signal** of the residual instantaneous overcurrent protection function is shown in Table 1-4.

Table 1-4 The binary output status signal of the residual IOC protection function

BINARY OUTPUT SIGNAL	SIGNAL TITLE	EXPLANATION
IOC50N_TrN_	Trip N _i	Internal trip command of the function

2.1.18.1.6. The Decision Logic (Decision logic)

The decision logic module combines the status signal binary and the binary parameter to generate the general trip command of the function.

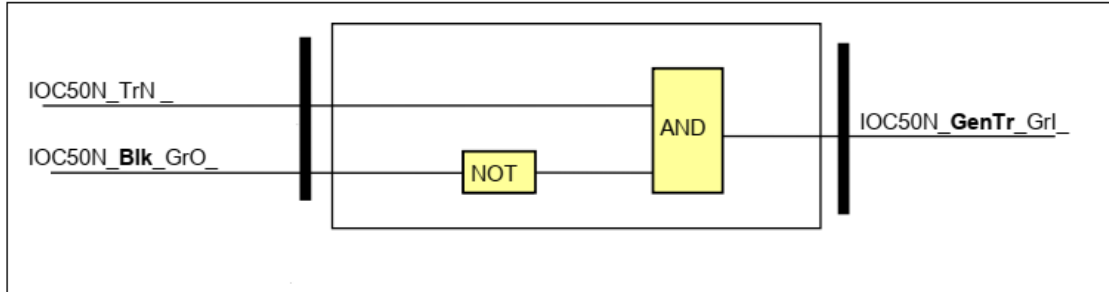

Figure 1-6 The logic scheme of the residual IOC protection function

Table 1-5 The binary input status signal of the residual IOC protection function

BINARY INPUT SIGNAL	SIGNAL TITLE	EXPLANATION
IOC50N_TrN_	Trip N	Internal trip command of the function

Binary status signal

The residual instantaneous overcurrent protection function has a binary input signal, which serves the purpose of disabling the function. **The conditions of disabling are defined by the user, applying the graphic equation editor.**

Table 1-6 The binary input signal of the residual IOC protection function

BINARY STATUS SIGNAL	SIGNAL TITLE	EXPLANATION
IOC50N_Blk_GrO_	Block	Input for disabling the function

Table 1-7 The binary output status signal of the decision logic

BINARY OUTPUT SIGNAL	SIGNAL TITLE	EXPLANATION
IOC50N_GenTr_GrI_	General Trip	General trip command of the function

2.1.18.2. Residual Instantaneous OC Function Overview

The graphic appearance of the residual instantaneous overcurrent protection function block is shown in Figure 2-1. This block shows all binary input and output status signals that are applicable in the graphic equation editor.

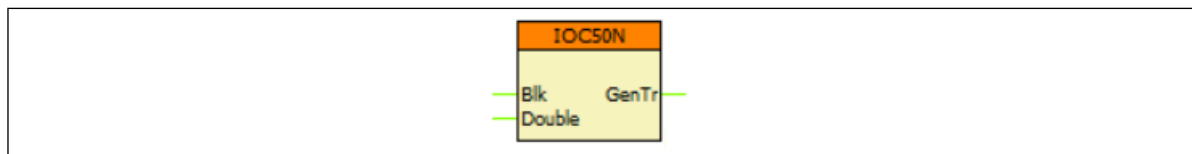

Figure 2-1 The function block of the residual instantaneous overcurrent protection

2.1.18.2.1. Settings

2.1.18.2.1.1. Parameters

The available parameters are listed below in order of their appearance in the *parameters* menu. If the setting range of a parameter should be extended, contact Protecta Support.

Table 2-1 Parameters of the residual instantaneous overcurrent protection function

TITLE	DIM	RANGE	STEP	DEFAULT	EXPLANATION
Operation	-	Off, Peak value, Fundamental value	-	Off	Parameter for enabling the function and selection type.
Start Current	%	10 – 1000*	1	200	Start value of the function, if the current exceeds this value, the function picks up and trips after the minimum operation time of the relay (t_{OP}).

*extendable to 3000 when using CT+/5151 module

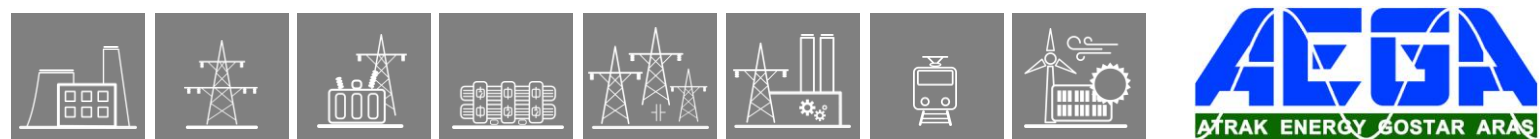

2.1.18.2.2. Function I/O

This section briefly describes the analogue and digital inputs and outputs of the function block.

2.1.18.2.2.1. Analogue inputs

The analogue inputs are the sampled values of the residual current.

2.1.18.2.2.2. Binary input signals (graphed output statuses)

The conditions of the binary inputs are defined by the user, applying the graphic equation editor (*Logic Editor*). Parts written in **bold** are seen on the left side of the function block in the Logic editor.

Table 2-2 The binary input signals of the residual IOC function

BINARY INPUT SIGNAL	SIGNAL TITLE	EXPLANATION
IOC50N_ Blk _GrO_	Block	Input for disabling the function
IOC50N_ Double _GrO_	Double	Input used to double the value of the parameter "Start Current".

2.1.18.2.2.3. Binary output signals (graphed input statuses)

These signals can be used in EuroCAP to assign to LED, user LCD object etc. Parts written in **bold** are seen on the right side of the function block in the *Logic Editor*.

Table 2-3 The binary output signals of the residual IOC function

BINARY OUTPUT SIGNAL	SIGNAL TITLE	EXPLANATION
IOC50N_ GenTr _GrI_	General Trip	General trip command of the function

2.1.18.2.2.4. Online data

The following values are visible in the *online data* page.

Table 2-4 Online data of the residual IOC function

SIGNAL TITLE	DIMENSION	EXPLANATION
General Trip	-	General trip command of the function

2.1.18.2.2.5. Events

The following events are generated in the event list, as well as sent to the SCADA according to the configuration.

Table 2-5 Generatable events of the residual IOC function

EVENT	VALUE	EXPLANATION
General Trip	off, on	General trip command of the function

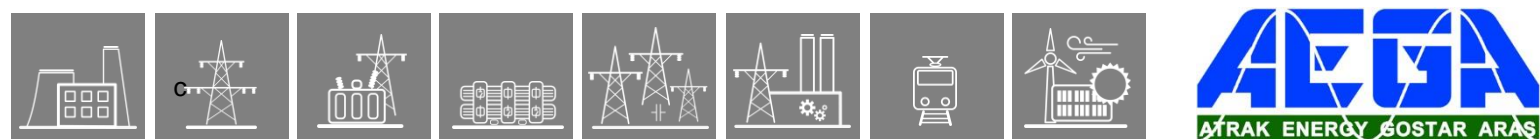

2.1.18.2.3. Technical Data

Table 2-6 Technical data of the residual IOC protection function

FUNCTION	VALUE	ACCURACY
<i>Using peak value calculation</i>		
Operating characteristic ($I > 0.1I_n$)	Instantaneous	< 6%
Reset ratio	0.85	
Operate time at $2 \cdot I_s$	< 15 ms	
Reset time*	< 40 ms	
Transient overreach	85%	
<i>Using Fourier fundamental harmonic calculation</i>		
Operating characteristic ($I > 0.1I_n$)	Instantaneous	< 3%
Reset ratio	0.85	
Operate time at $2 \cdot I_s$	< 25 ms	
Reset time*	< 60 ms	
Transient overreach	15%	

* Measured with signal contacts

2.1.18.2.4. Notes for Testing

Normally in the EuroProt+ devices the trip contacts are assigned to the Trip Logic function block, and not to the protection function blocks. Because of this, the testing personnel must make sure that the Trip Logic is switched on ('Operation' parameter is set to other than 'Off') before starting the tests, otherwise there will be no physical trip on the relay.

Being an instantaneous function, its connection to the Trip Logic function is done in the Fast Equations (by default) and not in the Logic Editor (usually, there are comments inserted in the Logic Editor if such connections exist). This can be checked in EuroCAP.

As the analogue sources can be changed by the user, it is possible to assign calculated or measured residual current to the input of the function block. This can be checked in the function block properties in EuroCAP.

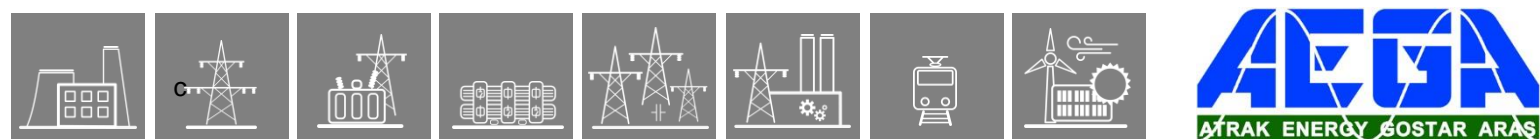

2.1.19. Generator inadvertent energizing protection

Inadvertent or accidental energizing of large generators while in still-stand can cause serious problems. This can be a consequence of faulty manual closing or flashover of the circuit breaker

Under these conditions, the machine starts like an induction motor, taking large currents from the network. As a consequence, within a short time (some seconds) the generator can be damaged. The generated heat in the rotor is similar to the effect of negative sequence current component, but here the speed difference between the rotating field and the rotor is approximately the synchronous speed only.

The application of generator inadvertent energizing protection function prevents this error state. In this process the pre-fault state of the generator is characterized by zero voltage, after energizing however overcurrent can be detected. The generator inadvertent energizing protection function recognizes this event sequence.

The protection function is composed by an under-voltage function and an instantaneous overcurrent function.

If the voltage is below the setting level in all three phases then a timer, delayed on pick-up by a timer parameter, sets to true state. This means disconnected state of the generator, and the instantaneous overcurrent stage of the function is enabled. The pick-up delay is needed to prevent operation of the function in case of external fault. This time delay setting value should be longer than the maximum clearing time of any external fault. If the generator is energized inadvertently and during the drop-off time of the timer started by the undervoltage relay the overcurrent function detects current above the current setting value, then the function operates. The undervoltage stage drops after time-out of the drop-off time, disabling the function. In case of inadvertent energizing, the drop-off time delay defines the pulse duration of the generated trip command. When the timer drops off, the output of the function is blocked.

2.1.19.1. Technical data

Function	Value	Accuracy
Operating characteristic	Undervoltage/overcurrent	
Drop-off ratio of overcurrent	0,85	
Drop-off ratio of undervoltage	1,05	
Accuracy of voltage measurement		2%
Accuracy of peak current measurement		6%
Accuracy of current fundamental harmonic component measurement		2%
Accuracy of definite time delay		±5% or ±15 ms, whichever is greater

Table 1-1 Technical data of the generator inadvertent energizing protection function

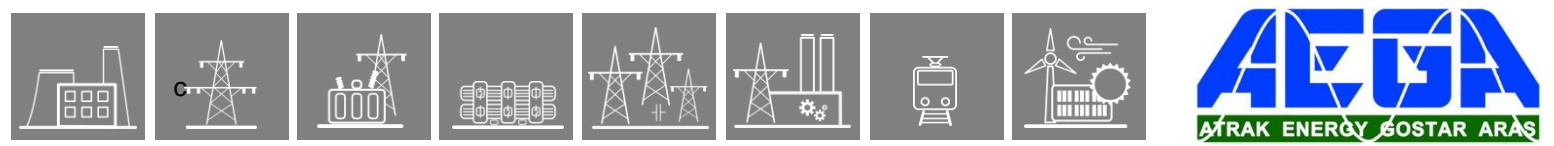

2.1.19.2. Parameters

2.1.19.2.1. Enumerated parameter

Parameter name	Title	Selection range	Default
VIOC50_Oper_EPar_	Operation	Off, Peak value, Fundamental value	Off

Table 1-2 Enumerated parameter of the generator inadvertent energizing protection function

2.1.19.2.2. Integer parameters

Parameter name	Title	Unit	Min	Max	Step	Default
VIOC50_StCurr_IPar_	Start Current	%	20	3000	1	200
VIOC50_StVol_IPar_	Start Voltage	%	30	130	1	90

Table 1-3 Integer parameters of the generator inadvertent energizing protection function

2.1.19.2.3. Timer parameters

Parameter name	Title	Unit	Min	Max	Step	Default
VIOC50_PickUp_TPar_	Pickup delay	ms	0	30000	1	1000
VIOC50_DropOut_TPar_	Dropout delay	ms	0	30000	1	100

Table 1-4 Timer parameters of the generator inadvertent energizing protection function

2.1.19.3. Binary status signals

2.1.19.3.1. Binary output status signals

Binary output status signal	Title	Explanation
VIOC50_TrL1_GrI_	Trip L1	Trip command of the function in phase L1
VIOC50_TrL2_GrI_	Trip L2	Trip command of the function in phase L2
VIOC50_TrL3_GrI_	Trip L3	Trip command of the function in phase L3
VIOC50_GenTr_GrI_	General trip	General trip command of the function

Table 1-5 Binary output status signals of the generator inadvertent energizing protection function

2.1.19.3.2. Binary input status signals

Binary input status signal	Title	Explanation
VIOC50_Blk_GrO_	Block	Output status of a graphic logic defined by the user to disable the protection function
VIOC50_VTS_GrO_	Block from VTS	In case of voltage transformer failure this signal disables the protection function

Table 1-6 Binary input status signals of the generator inadvertent energizing protection function

2.1.19.4. Function block

The function block of the generator inadvertent energizing protection function block is shown in Figure 1-1. This figure shows all input and output status signals available in graphic logic editor.

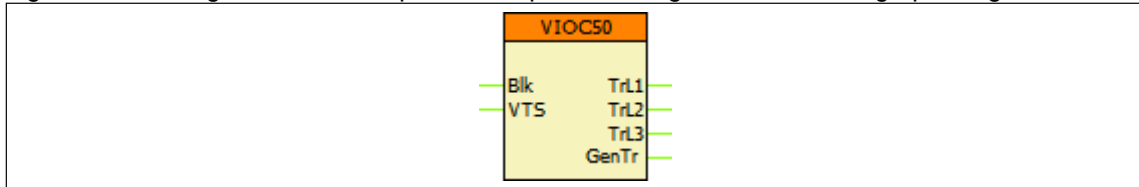

Figure 1-1 The function block of the generator inadvertent energizing protection function

2.1.20.1.1.2. Standard dependent time characteristics

Operating characteristics:

$$t(G) = TMS \left[\frac{k}{\left(\frac{G}{G_s}\right)^\alpha - 1} + c \right] \text{ when } G > G_s$$

where

- t(G)(seconds) theoretical operate time with constant value of G,
- k, c constants characterizing the selected curve (in seconds),
- α constants characterizing the selected curve (no dimension),
- G measured value of the characteristic quantity, Fourier base harmonic of the phase currents (IL1Four, IL2Four, IL3Four),
- G_s preset value of the characteristic quantity ("Start current" parameter),
- TMS preset time multiplier (no dimension).

Table 1-1 The constants of the standard dependent time characteristics

	IEC REF	TITLE	kr	c	α
1	A	IEC Inv	0,14	0	0,02
2	B	IEC VeryInv	13,5	0	1
3	C	IEC ExtInv	80	0	2
4		IEC LongInv	120	0	1
5		ANSI Inv	0,0086	0,0185	0,02
6	D	ANSI ModInv	0,0515	0,1140	0,02
7	E	ANSI VeryInv	19,61	0,491	2
8	F	ANSI ExtInv	28,2	0,1217	2
9		ANSI LongInv	0,086	0,185	0,02
10		ANSI LongVeryInv	28,55	0,712	2
11		ANSI LongExtInv	64,07	0,250	2

The end of the effective range of the dependent time characteristics (G_D) is:

$$G_D = 20 * G_s$$

Above this value the theoretical operating time is definite:

$$t(G) = TMS \left[\frac{k}{\left(\frac{G_D}{G_s}\right)^\alpha - 1} + c \right] \text{ when } G > G_D = 20 * G_s$$

Additionally, a minimum time delay can be defined by parameter “Min Time Delay”. This delay is valid if it is longer than $t(G)$, defined by the formula above.

The inverse characteristic is valid above $G_T = 1,1 * G_s$. Above this value the function is guaranteed to operate.

Resetting characteristics:

- For IEC type characteristics the resetting is after a fix time delay defined by “Reset delay”,
- for ANSI types however according to the formula below:

$$t_r(G) = TMS \left[\frac{k_r}{1 - \left(\frac{G}{G_s}\right)^\alpha} \right] \text{ when } G < G_s$$

where

- $t(G)$ (seconds) theoretical reset time with constant value of G ,
- k_r constants characterizing the selected curve (in seconds),
- α constants characterizing the selected curve (no dimension),
- G measured value of the characteristic quantity, Fourier base harmonic of the phase currents,
- G_s preset value of the characteristic quantity (“Start current” parameter),
- TMS preset time multiplier (no dimension).

Table 1-2 The resetting constants of the standard dependent time characteristics

	IEC REF	TITLE	k_r	α
1	A	IEC Inv	Resetting after fix time delay, according to preset parameter “Reset delay”	
2	B	IEC VeryInv		
3	C	IEC ExtInv		
4		IEC LongInv		
5		ANSI Inv	0,46	2
6	D	ANSI ModInv	4,85	2
7	E	ANSI VeryInv	21,6	2
8	F	ANSI ExtInv	29,1	2
9		ANSI LongInv	4,6	2
10		ANSI LongVeryInv	13,46	2
11		ANSI LongExtInv	30	2

2.1.20.1.2. Structure of the overcurrent protection algorithm

Fig.1-2 shows the structure of the overcurrent protection (TOC51) algorithm.

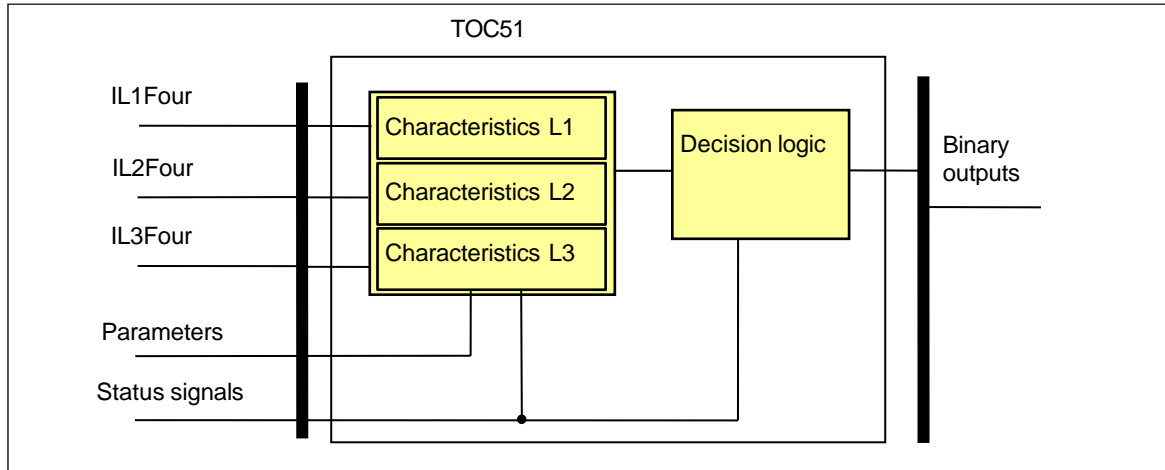

Figure 1-2 Structure of the overcurrent protection algorithm

The **inputs** are

the RMS value of the fundamental Fourier component of three phase currents,
parameters,
status signals.

The **outputs** are

the binary output status signals.

The **software modules** of the overcurrent protection function:

Characteristics

This module calculates the required time delay based on the Fourier components of the phase currents.

Decision logic

The decision logic module combines the status signals to generate the trip command of the function.

The following description explains the details of the individual components.

2.1.20.1.3. The definite time and the inverse type characteristics (characteristics)

This module calculates the required time delay based on the Fourier components of the phase currents. The formulas applied are described in Chapter 1.1.

The **inputs** are the RMS value of the fundamental Fourier component of the phase currents (IL1Four, IL2Four, IL3Four) and parameters.

The **outputs** are the status signals of the three phases individually. These indicate the started state and the generated trip command if the time delay determined by the characteristics expired.

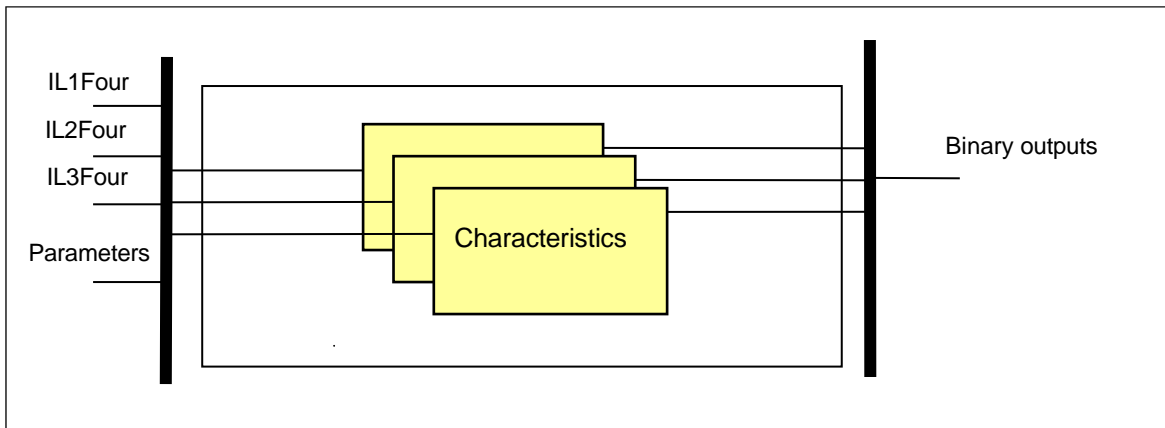

Figure 1-3 Schema of the characteristic calculation

The inverse type characteristics are also presented graphically on the following pages. These diagrams assume 100% setting value for the Start current parameter (GS), 1 for the Time multiplier (TMS) and 0 for the Min. time delay.

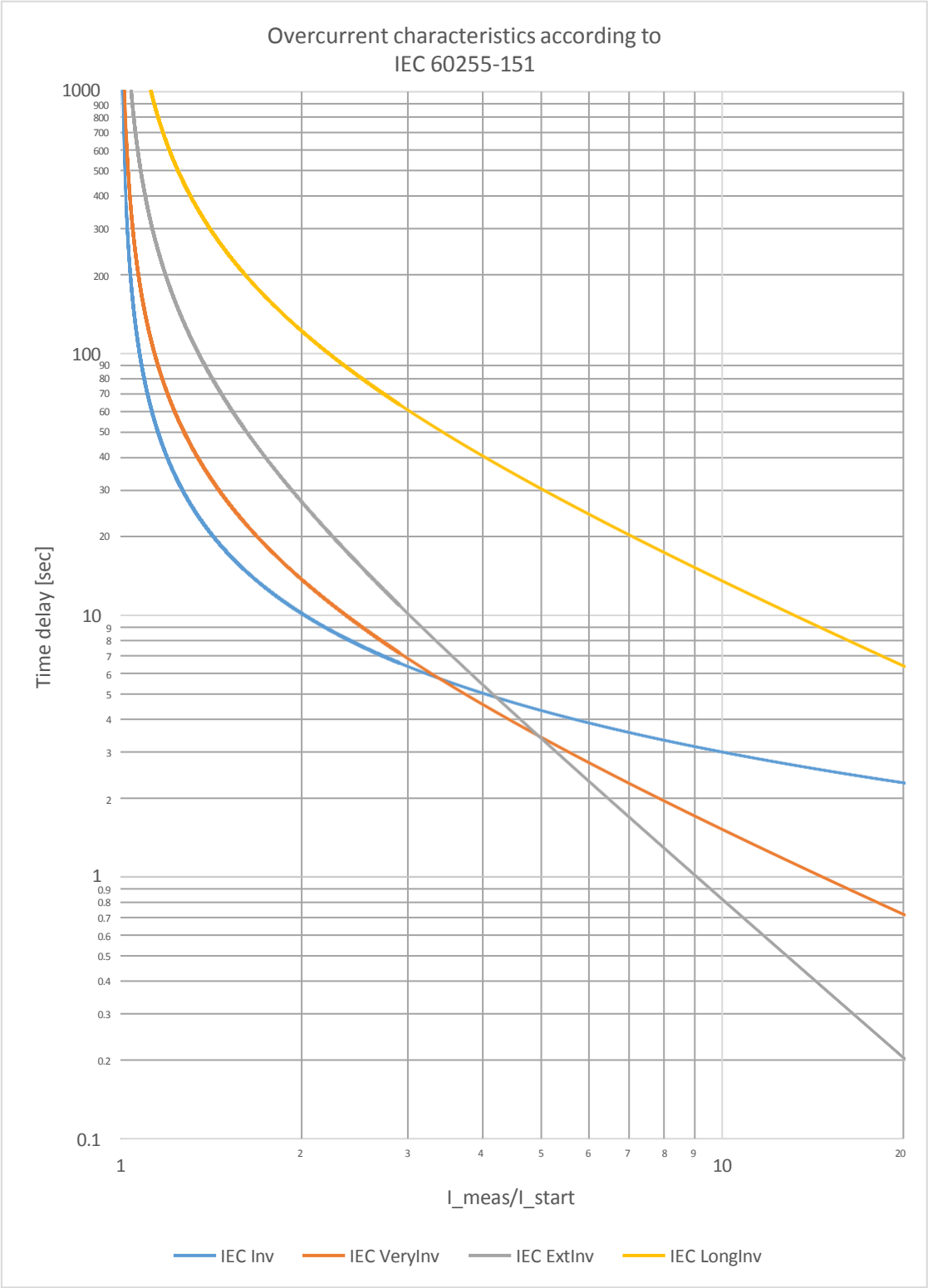

Figure 1-4 Overcurrent characteristics according to IEC 60255-151

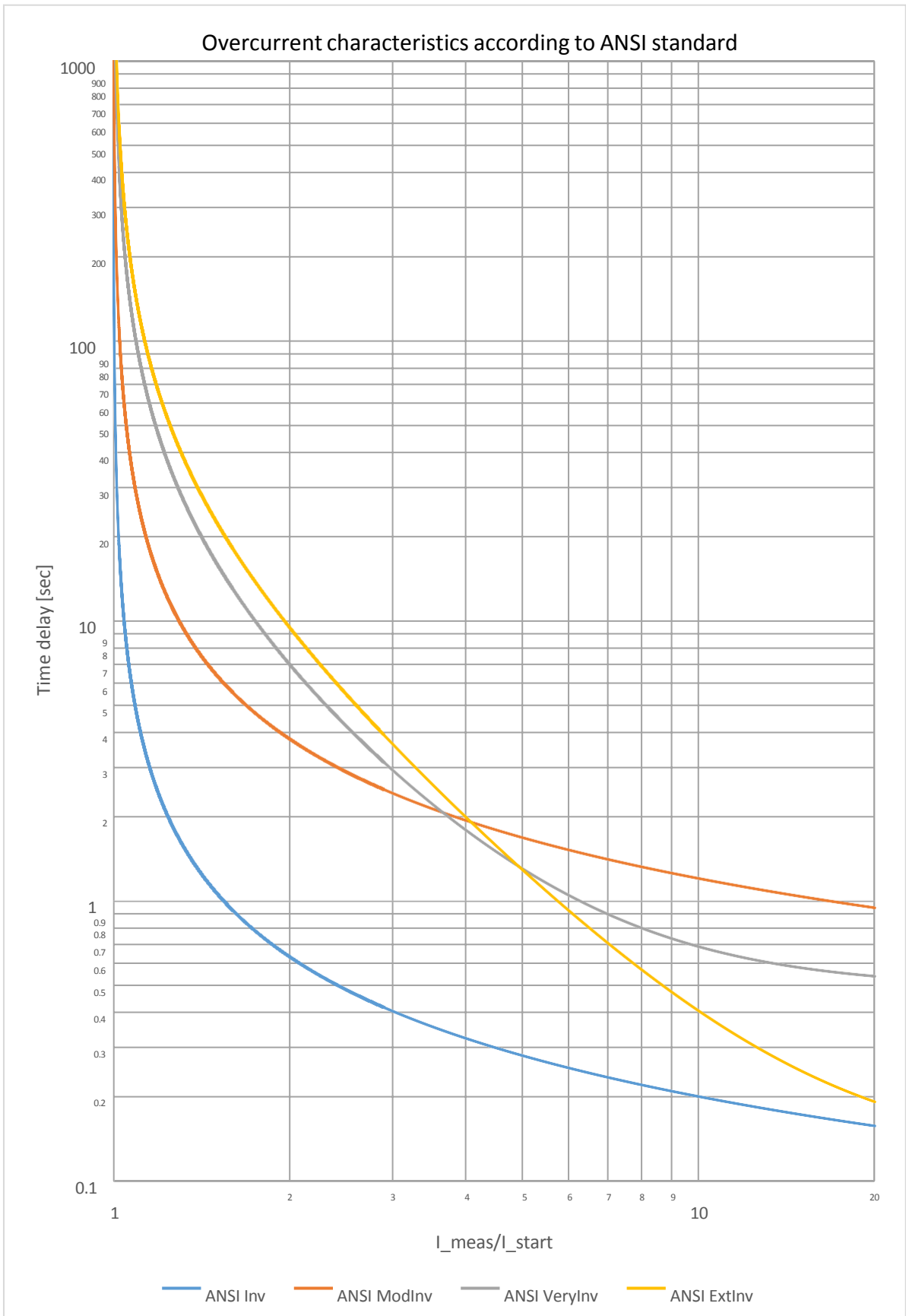

Figure 1-5 Overcurrent characteristics according to ANSI standard

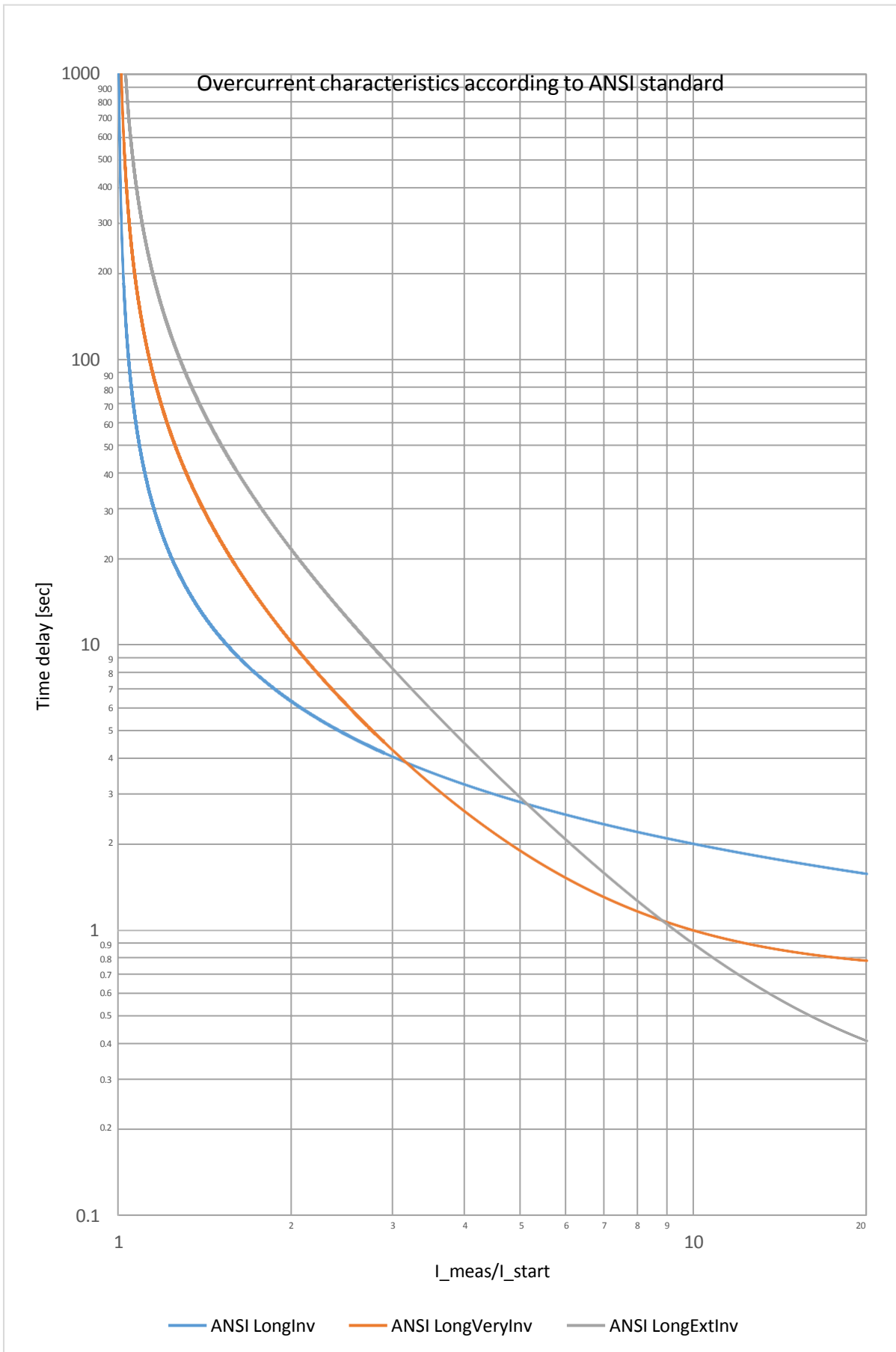

Figure 1-6 Overcurrent characteristics according to ANSI standard

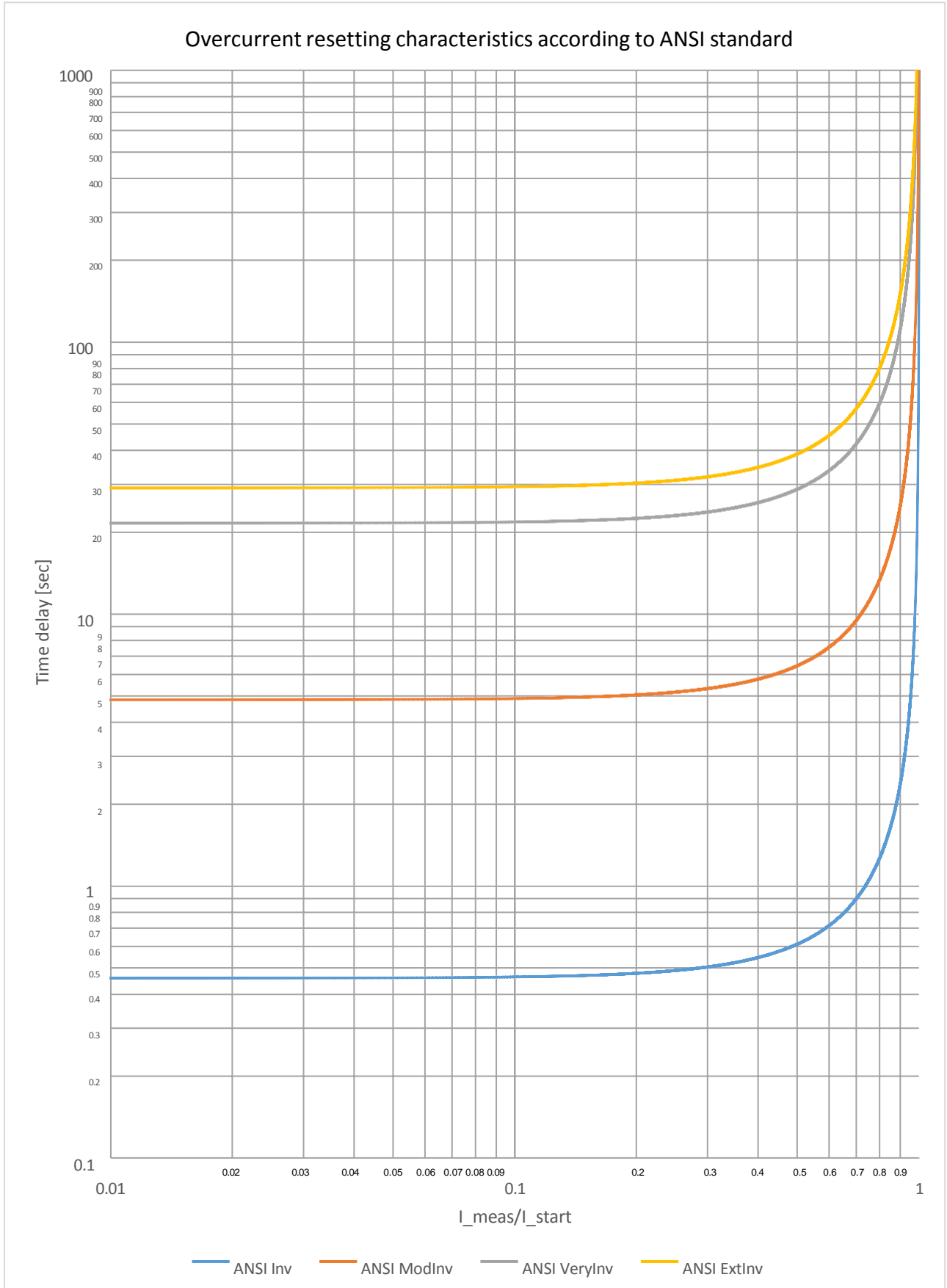

Figure 1-7 Overcurrent resetting characteristics according to ANSI standard

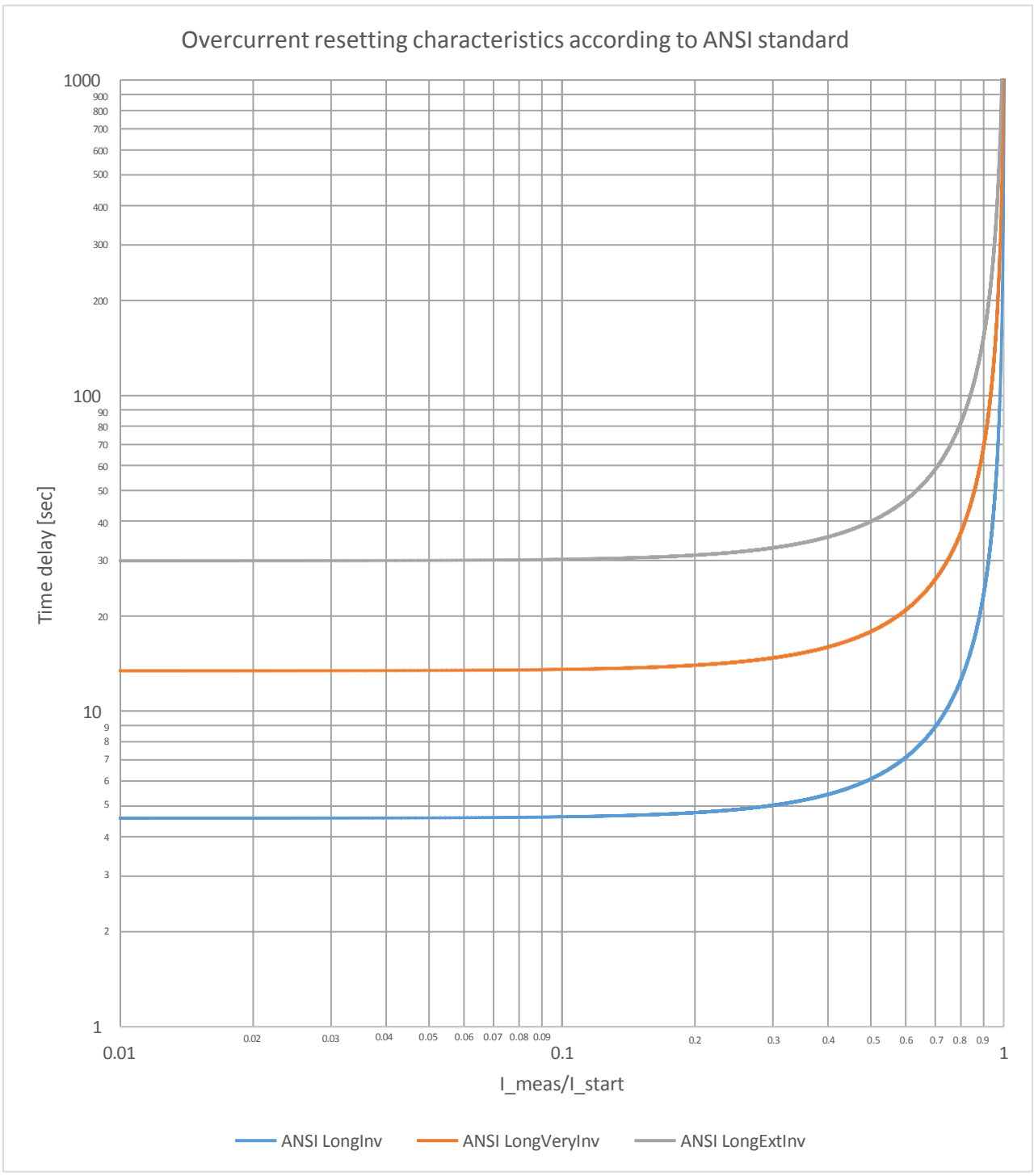

Figure 1-8 Overcurrent resetting characteristics according to ANSI standard

2.1.20.1.4. The decision logic (Decision logic)

The decision logic module combines the status signals to generate the general start signal and general trip command of the function.

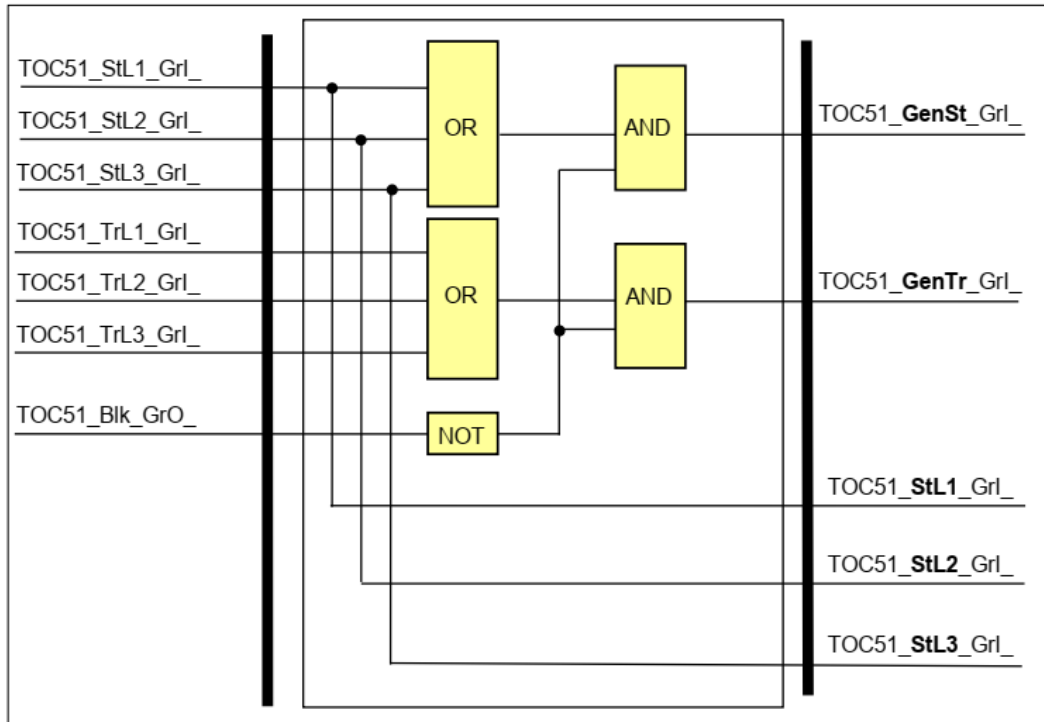

Figure 1-9 The logic scheme of the overcurrent protection function

Table 1-3 The binary input status signals of the overcurrent protection function

BINARY INPUT SIGNALS	SIGNAL TITLE	EXPLANATION
TOC51_StL1_GrI_	Start L1	Starting of the function in phase L1
TOC51_TrL1_GrI_	Trip L1	Trip command of the function in phase L1
TOC51_StL2_GrI_	Start L2	Starting of the function in phase L2
TOC51_TrL2_GrI_	Trip L2	Trip command of the function in phase L2
TOC51_StL3_GrI_	Start L3	Starting of the function in phase L3
TOC51_TrL3_GrI_	Trip L3	Trip command of the function in phase L3



Binary status signals

The overcurrent protection function has a binary input signal, which serves the purpose of disabling the function. **The conditions of disabling are defined by the user, applying the graphic equation editor.**

Table 1-4 The binary input signal of the overcurrent protection function

BINARY STATUS SIGNAL	EXPLANATION
TOC51_Blk_GrO_	Output status of a graphic equation defined by the user to disable the overcurrent protection function.

Table 1-5 The binary output status signals of the overcurrent protection function

BINARY OUTPUT SIGNALS	SIGNAL TITLE	EXPLANATION
TOC51_StL1_Grl_	Start L1	Starting of the function in phase L1
TOC51_StL2_Grl_	Start L2	Starting of the function in phase L2
TOC51_StL3_Grl_	Start L3	Starting of the function in phase L3
TOC51_GenSt_Grl_	Gen. Start	General starting of the function
TOC51_GenTr_Grl_	Gen. Trip	General trip command of the function

2.1.20.2. 3ph overcurrent protection function overview

The function block of the three-phase overcurrent protection function is shown in Figure 2-1. This block shows all binary input and output status signals that are applicable in the graphic equation editor.

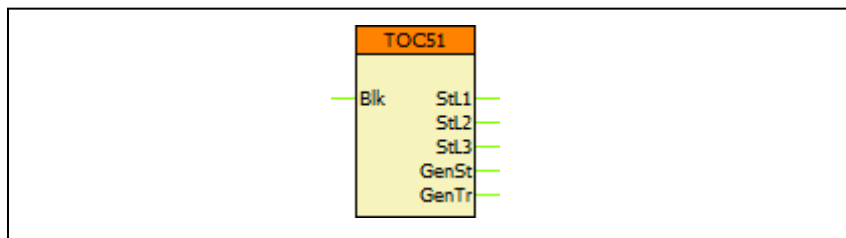

Figure 2-1 The function block of the overcurrent protection function

2.1.20.2.1. Settings

2.1.20.2.1.1. Parameters

Table 2-1 Parameters of the 3ph overcurrent protection function

TITLE	DIM	RANGE	STEP	DEFAULT	EXPLANATION
Operation	-	Off, Definite Time, IEC Inv, IEC VeryInv, IEC ExtInv, IEC LongInv, ANSI Inv, ANSI ModInv, ANSI VeryInv, ANSI ExtInv, ANSI LongInv, ANSI LongVeryInv, ANSI LongExtInv	-	Off	Enabling the function by choosing the characteristics.
Start Current	%	10 – 3000	1	200	Starting current of the function.
Time Multiplier	-	0.05 – 15.0	0.01	200	Time multiplier of the inverse characteristics (OC module)
Min Time Delay	msec	40 – 60000	1	100	Minimal time delay for the inverse characteristics
Definite Time Delay	msec	40 – 60000	1	100	Time delay setting for the definite time characteristics
Reset Time	msec	60 – 60000	1	100	Reset time for the IEC inverse characteristics

2.1.20.2.2. Function I/O

This section describes briefly the analogue and digital inputs and outputs of the function block.

2.1.20.2.2.1. Analogue inputs

The function uses the sampled values of the three phase currents.

2.1.20.2.2.2. Binary output signals (graphed input statuses)

The **binary output status signals** of the three-phase overcurrent protection function are listed in Table 2-2. **Parts** written in **bold** are seen on the function block in the logic editor.

Table 2-2 The binary output status signals of the 3ph overcurrent protection function

BINARY OUTPUT SIGNALS	SIGNAL TITLE	EXPLANATION
TOC51_ St L1_Grl_	Start L1	Starting of the function in phase L1
TOC51_TrL1_Grl_	Trip L1	Trip command of the function in phase L1
TOC51_ St L2_Grl_	Start L2	Starting of the function in phase L2
TOC51_TrL2_Grl_	Trip L2	Trip command of the function in phase L2
TOC51_ St L3_Grl_	Start L3	Starting of the function in phase L3
TOC51_TrL3_Grl_	Trip L3	Trip command of the function in phase L3
TOC51_ GenSt _Grl_	General Start	General start of the function
TOC51_ GenTr _Grl_	General Trip	General trip command of the function

2.1.20.2.2.3. Binary input signals (graphed output statuses)

The overcurrent protection function has a binary input signal, which serves the purpose of disabling the function. **The conditions of disabling are defined by the user, applying the graphic equation editor.**

Table 2-3 The binary input status signals of the 3ph overcurrent protection function

BINARY INPUT SIGNAL	EXPLANATION
TOC51_ Blk _GrO_	Output status of a graphic equation defined by the user to disable the overcurrent protection function.

2.1.20.2.2.4. On-line data

Visible values on the on-line data page:

Table 2-4 On-line data of the 3ph overcurrent protection function

SIGNAL TITLE	DIMENSION	EXPLANATION
Start L1	-	Starting of the function in phase L1
Trip L1	-	Trip command of the function in phase L1
Start L2	-	Starting of the function in phase L2
Trip L2	-	Trip command of the function in phase L2
Start L3	-	Starting of the function in phase L3
Trip L3	-	Trip command of the function in phase L3
General Start	-	General start of the function
General Trip	-	General trip command of the function

2.1.21. Residual overcurrent protection function

The residual overcurrent protection function can realize definite time or inverse time characteristics according to IEC or IEEE standards, based on the RMS value of the fundamental Fourier component of a single measured current, which can be the measured residual current at the neutral point ($3I_0$) or the calculated zero sequence current component. The characteristics are harmonized with IEC 60255-151, Edition 1.0, 2009-08.

2.1.21.1. Operating characteristics

2.1.21.1.1. Independent time characteristic

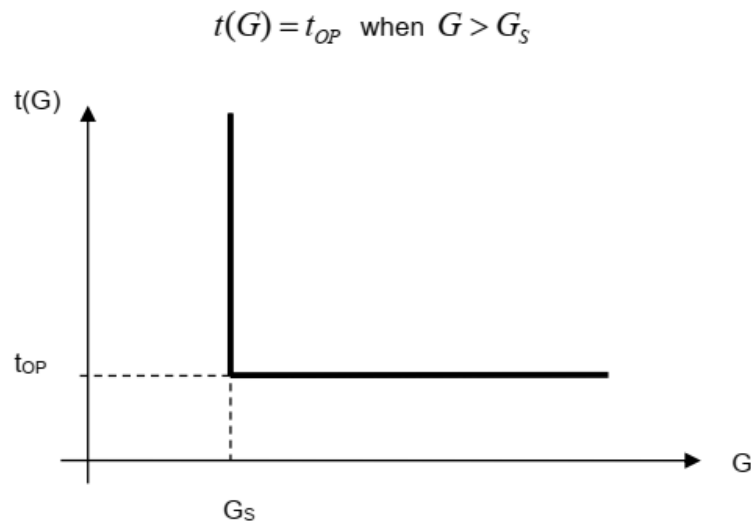

Figure 1-1 Overcurrent independent time characteristic

where	
t_{OP} (seconds)	theoretical operating time if $G > G_s$, fix, according to the preset parameter,
G	measured value of the characteristic quantity, Fourier base harmonic of the residual current,
G_s	preset value of the characteristic quantity (TOC51N_StCurr_IPar_, Start current).

2.1.21.1.2. Standard dependent time characteristics

Operating characteristics:

$$t(G) = TMS \left[\frac{k_r}{\left(\frac{G}{G_s} \right)^\alpha - 1} + c \right] \text{ when } G > G_s$$

where

t(G)(seconds)

k_r, c

α

G

G_s

TMS

theoretical operate time with constant value of G,
 constants characterizing the selected curve (in seconds),
 constant characterizing the selected curve (no dimension),
 measured value of the characteristic quantity, Fourier base harmonic
 of the residual current (INFour),
 preset value of the characteristic quantity (TOC51N_StCurr_IPar_
 Start current),
 preset time multiplier (no dimension).

	IEC ref		k _r	c	α
1	A	IEC Inv	0,14	0	0,02
2	B	IEC VeryInv	13,5	0	1
3	C	IEC ExtInv	80	0	2
4		IEC LongInv	120	0	1
5		ANSI Inv	0,0086	0,0185	0,02
6	D	ANSI ModInv	0,0515	0,1140	0,02
7	E	ANSI VeryInv	19,61	0,491	2
8	F	ANSI ExtInv	28,2	0,1217	2
9		ANSI LongInv	0,086	0,185	0,02
10		ANSI LongVeryInv	28,55	0,712	2
11		ANSI LongExtInv	64,07	0,250	2

Table 1-1 The constants of the standard dependent time characteristics

Resetting characteristics:

$$t_r(G) = TMS \left[\frac{k_r}{1 - \left(\frac{G}{G_s}\right)^\alpha} \right] \text{ when } G < G_s$$

where

$t_r(G)$ (seconds)

k_r

α

G

G_s

TMS

theoretical reset time with constant value of G ,
 constants characterizing the selected curve (in seconds),
 constant characterizing the selected curve (no dimension),
 measured value of the characteristic quantity, Fourier base harmonic
 of the residual current,
 preset value of the characteristic quantity (TOC51N_StCurr_IPar_
 Start current),
 preset time multiplier (no dimension).

	IEC ref		k_r	α
1	A	IEC Inv	Resetting after fix time delay, according to preset parameter TOC51N_Reset_TPar_ "Reset delay"	
2	B	IEC VeryInv		
3	C	IEC ExtInv		
4		IEC LongInv		
5		ANSI Inv	0,46	2
6	D	ANSI ModInv	4,85	2
7	E	ANSI VeryInv	21,6	2
8	F	ANSI ExtInv	29,1	2
9		ANSI LongInv	4,6	2
10		ANSI LongVeryInv	13,46	2
11		ANSI LongExtInv	30	2

Table 1-2 The resetting constants of the standard dependent time characteristics

The inverse type characteristics are also combined with a minimum time delay, the value of which is set by user parameter TOC51N_MinDel_TPar_ (Min. Time Delay).

The end of the effective range of the dependent time characteristics (G_D) is:

$$G_D = 20 * G_s$$

Above this value the theoretical operating time is definite:

$$t(G) = TMS \left[\frac{k_r}{\left(\frac{G_D}{G_s}\right)^\alpha - 1} + c \right] \text{ when } G > G_D = 20 * G_s$$

The combined logic requires expiry both the time defined by the inverse characteristic with the definite section AND the expiry of the minimum time defined by the "Min. Time Delay" parameter.

The inverse characteristic is valid above $G_T = 1,1 * G_s$. Above this value the function is guaranteed to operate.

2.1.21.2. Structure of the residual overcurrent protection algorithm

Fig.1-2 shows the structure of the residual overcurrent protection (TOC51N) algorithm.

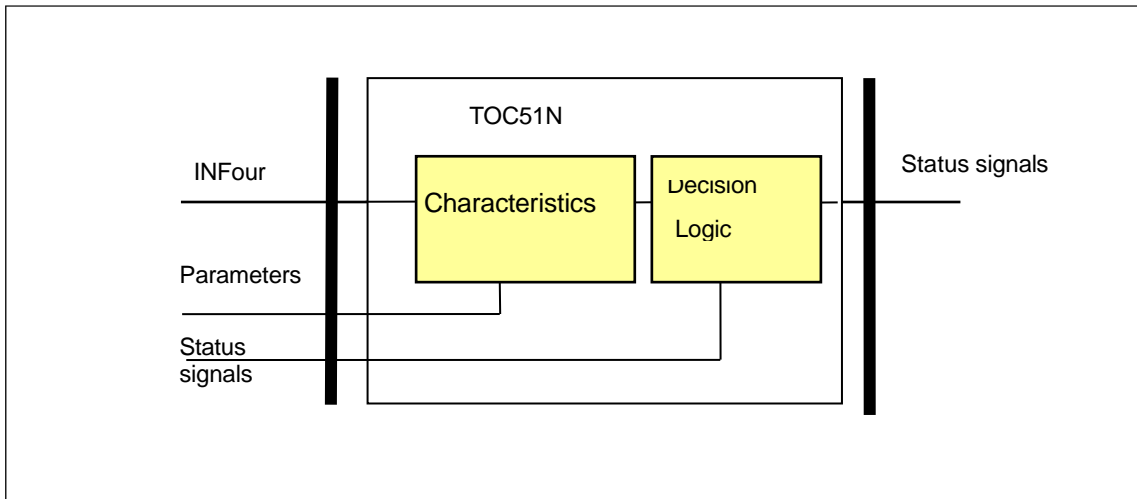

Figure 1-2 Structure of the residual overcurrent protection algorithm

The **inputs** are

the RMS value of the fundamental Fourier component of the residual current ($I_N=3I_0$),
parameters,
status signals.

The **outputs** are

the binary output status signals.

The **software modules** of the residual overcurrent protection function:

Characteristics

This module calculates the required time delay based on the RMS value of the fundamental Fourier component of the residual current.

Decision logic

The decision logic module combines the status signals to generate the trip command of the function.

The following description explains the details of the individual components.

2.1.21.3. The definite time and the inverse type characteristics

This module calculates the required time delay based on the Fourier components of the residual current. The formulas applied are described in Chapter 1.1.

The **inputs** are the basic Fourier components of the residual current (INFour) and parameters.

The **outputs** are the internal status signals of the function. These indicate the started state and the generated trip command if the time delay determined by the characteristics expired.

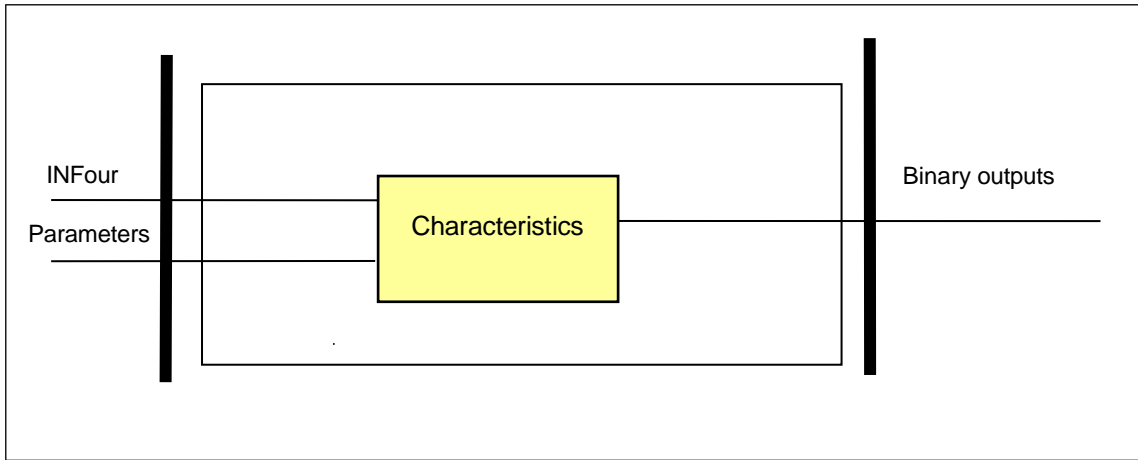

Figure 1-3 Schema of the characteristic calculation

Enumerated parameter

Parameter name	Title	Selection range	Default
Parameter for type selection			
TOC51N_Oper_EPar_	Operation	Off, DefinitTime, IEC Inv, IEC VeryInv, IEC ExtInv, IEC LongInv, ANSI Inv, ANSI ModInv, ANSI VeryInv, ANSI ExtInv, ANSI LongInv, ANSI LongVeryInv, ANSI LongExtInv	Off

Table 1-3 The enumerated parameters of the residual overcurrent protection function

Integer parameters

Parameter name	Title	Unit	Min	Max	Step	Default
Starting current parameter:						
TOC51N_StCurr_IPar_	Start Current *	%	10	1000	1	50
TOC51N_StCurr_IPar_	Start Current **	%	5	1000	1	50

* In = 1 A or 5 A

** In = 200 mA or 1 A

Table 1-4 The integer parameters of the residual overcurrent protection function

Float parameter

Parameter name	Title	Unit	Min	Max	Step	Default
Time multiplier of the inverse characteristics (OC module)						
TOC51N_Multip_FPar_	Time Multiplier		0.05	15	0.01	1.0

Table 1-5 Float parameter of the OC function block

Timer parameters

Parameter name	Title	Unit	Min	Max	Step	Default
Minimal time delay for the inverse characteristics:						
TOC51N_MinDel_TPar_	Min Time Delay *	msec	40	60000	1	100
Definite time delay:						
TOC51N_DefDel_TPar_	Definite Time Delay **	msec	40	60000	1	100
Reset time delay for the inverse characteristics:						
TOC51N_Reset_TPar_	Reset Time*	msec	60	60000	1	100

*Valid for inverse type characteristics only

**Valid for definite type characteristics only

Table 1-6 Timer parameters of the residual overcurrent protection function

The **binary output status signals** of the residual overcurrent protection function are listed in Table 1-7.

Binary output signals	Signal title	Explanation
TOC51N_St_Grl_	Start L1	Starting of the function
TOC51N_Tr_Grl_	Trip L1	Trip command of the function

Table 1-7 The binary output status signals of the residual overcurrent protection function

2.1.21.4. The decision logic (Decision logic)

The decision logic module combines the status signals to generate the trip command of the function.

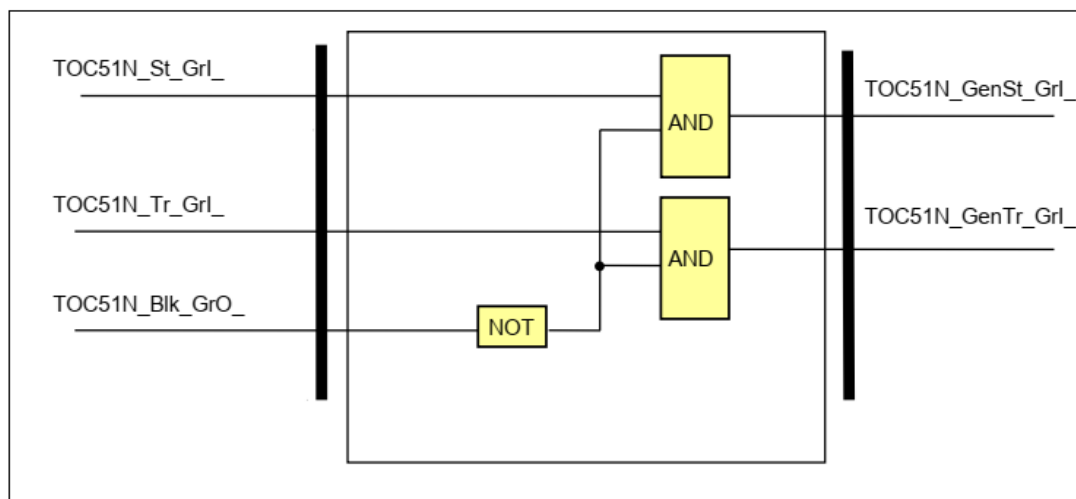

Figure 1-4 The (simplified) logic scheme of the residual overcurrent protection function

Binary input signals	Signal title	Explanation
TOC51N_St_Grl_	Start	Starting of the function
TOC51N_Tr_Grl_	Trip	Trip command of the function

Table 1-8 The binary input status signals of the residual overcurrent protection function

Binary status signals

The residual overcurrent protection function has a binary input signal, which serves the purpose of disabling the function. **The conditions of disabling are defined by the user, applying the graphic equation editor.**

Binary status signal	Explanation
TOC51N_Blk_GrO_	Output status of a graphic equation defined by the user to disable the residual overcurrent protection function.

Table 1-9 The binary input signal of the residual overcurrent protection function

Binary output signals	Signal title	Explanation
TOC51N_GenSt_Grl_	General Start	General starting of the function
TOC51N_GenTr_Grl_	General Trip	General trip command of the function

Table 1-10 The binary output status signals of the residual overcurrent protection function

2.1.21.5. Technical summary

2.1.21.5.1. Technical data

Function	Value	Accuracy
Operating accuracy *	$20 \leq G_s \leq 1000$	< 3 %
Operate time accuracy		$\pm 5\%$ or ± 15 ms, whichever is greater
Reset ratio	0,95	
Reset time * Dependent time char. Definite time char.	Approx 60 ms	< 5% or ± 35 ms, whichever is greater
Transient overreach		2 %
Pickup time	≤ 40 ms	
Overshot time Dependent time char. Definite time char.	30 ms 50 ms	
Influence of time varying value of the input current (IEC 60255-151)		< 4 %

* Measured in version $I_n = 200$ mA

Table 1-11 Technical data of the residual overcurrent protection function

2.1.21.5.2. The parameters

The parameters are summarized in Chapter 1.3.

2.1.21.5.3. The binary input status signals

Binary input signal

The residual overcurrent protection function has a binary input signal, which serves the purpose of disabling the function. **The conditions of disabling are defined by the user, applying the graphic equation editor.**

Binary input signal	Explanation
TOC51N_Blk_GrO_	Output status of a graphic equation defined by the user to disable the residual overcurrent protection function.

Table 1-12 The binary input signal of the residual overcurrent protection function

2.1.21.5.4. The binary output status signals

The **binary output status signals** of the residual overcurrent protection function are listed in Table 1-13.

Binary output signals	Signal title	Explanation
TOC51N_GenSt_Grl_	General Start	General starting of the function
TOC51N_GenTr_Grl_	General Trip	General trip command of the function

Table 1-13 The binary output status signals of the residual overcurrent protection function

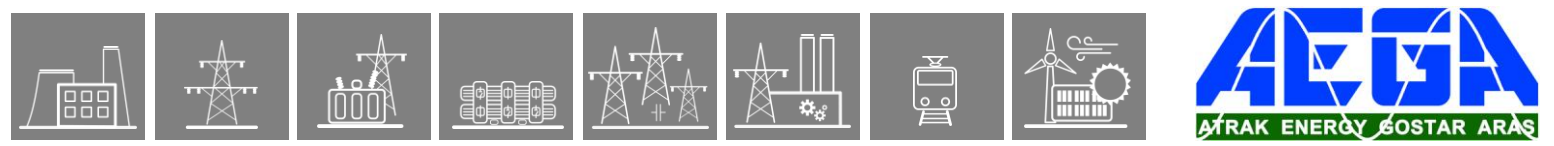

2.1.21.5.5. The function block

The function block of the residual overcurrent protection function is shown in Figure 1-5. This block shows all binary input and output status signals that are applicable in the graphic equation editor.

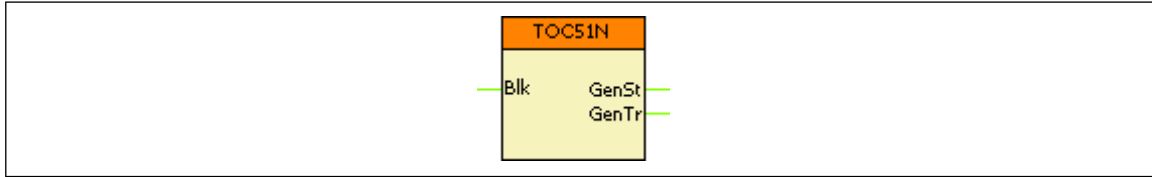
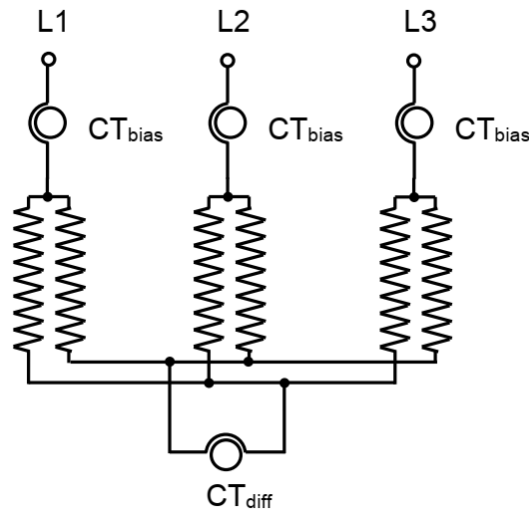

Figure 1-5 The function block of the residual overcurrent protection function

2.1.22. Inter-turn fault protection function based on current measurement

2.1.22.1. Introduction

In generators constructed for parallel windings, there is no current in the current transformer connected between the star points of the windings. The small current due to the natural asymmetry can be neglected.



A short circuit within a winding or between the turns of the parallel windings results high local fault current, but in the phase currents of the generator this current cannot be detected. This means that this kind of faults cannot be cleared by an overcurrent protection function.

The differential current between the two star points however is a measurable value. The numerical base harmonic filter of the applied algorithm enables sensitive setting for current detection. Due to the relatively large false differential current in case of external fault, a biased characteristic is applied. The biasing current is the maximum of the measured phase currents.

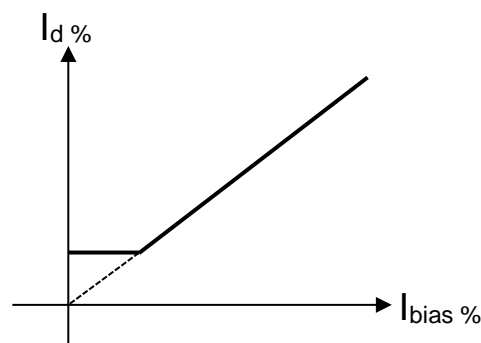

The horizontal axis of the operating characteristic is drawn as the percent of the phase current transformer rated current, the scaling of the vertical axis is in percent of the crated value of the current transformer into the differential branch.

As the turn's ratio of the current transformer in the differential branch is much less than that of phase current transformers (one tenth or one over twenty), the decision can be performed in high precision.

If the generator has no parallel windings, this method cannot be applied. For these configurations, the application of the protection function based on voltage measurement is recommended.

2.1.22.2. Technical data

Function	Value	Accuracy
Characteristic	Definite time delay	<2%
Drop-off ratio	0.95	
Time delay accuracy		±5% or ±15 ms, whichever is greater
Drop-off time	16 – 31 ms	

2.1.22.3. Parameters

Enumerated type parameter

Parameter name	Title	Selection range	Default
Enabling of the function			
IntTu_Oper_EPar_	Operation	Off, On	Off

Integer type parameters

Parameter name	Title	Unit	Min	Max	Step	Default
Minimum operating current						
IntTu_IPhBase_IPar_	Base sensitivity	%	10	800	1	50
Slope of biasing						
IntTu_IPhBias_IPar_	Bias	%	20	500	1	100

Timer parameters

Parameter name	Title	Unit	Min	Max	Step	Default
Definite time delay						
IntTu_Delay_TPar_	Time delay	msec	0	60000	1	500

Binary input status signals

Input status signal	Title	Explanation
IntTu_BlK_GrO_	Block	The active state of this status signal blocks the operation of the protection function. This signal can be edited by the user using the graphic logic editor.

Binary output status signals

Output status signal	Title	Explanation
IntTu_GenSt_GrI_	Start	The function started
IntTu_GenTr_GrI_	Trip	The function generated a TRIP command

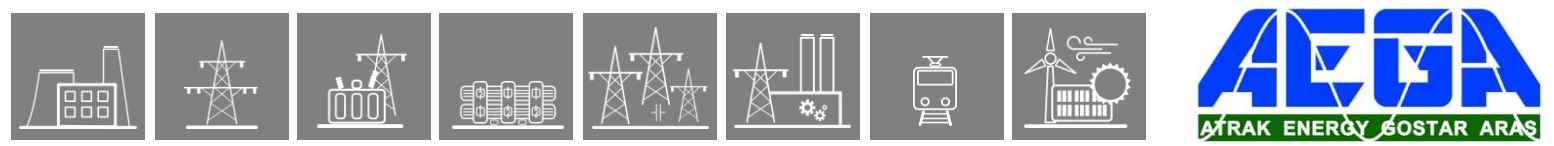

2.1.23. Voltage Dependent Overcurrent

2.1.23.1. Application

When the current in normal operation is higher than the lowest fault current, then it is not possible to set an overcurrent protection correctly based on current values only. If the voltage during fault is considerably below the lowest voltage during operation, then the voltage values can be applied to distinguish between faulty state and normal operating state. This is the essence of the voltage dependent overcurrent protection function.

The function is based on an overcurrent function that realizes definite time characteristic based on three phase currents. The operation of this overcurrent function is restrained or controlled by three phase voltages. The function operates in three phases individually, but the generated general start signal and the general trip command is the OR relationship of the three decisions.

The function can be blocked by a user-defined signal or by the voltage transformer supervision function block if the measured voltage is not available.

This function can be applied as main protection for medium-voltage applications or generator overcurrent protection.

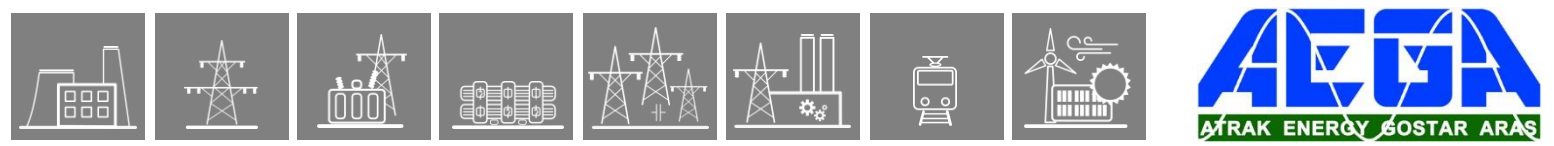

2.1.23.1.1.2. Voltage controlled characteristics

In this case the overcurrent protection operates only if the voltage is below the “U Low Limit” value and the current is above the “Start Current” value. (No operation is expected if the voltage is above the U Low Limit” value.)

The threshold current is the constant “Start Current” value. The voltage controlled characteristic is shown in [Figure 1-2](#).

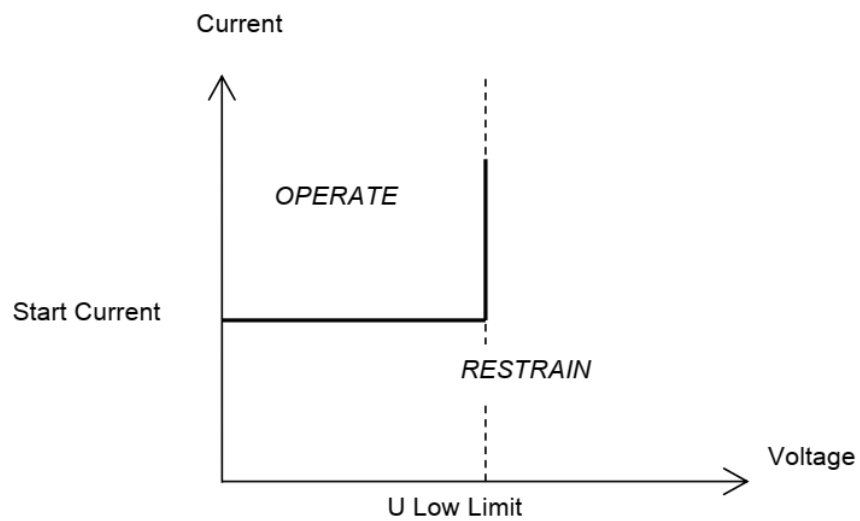

Figure 1-2 Voltage controlled characteristic

2.1.23.1.2. Structure of the protection algorithm

Fig.1-3 shows the structure of the voltage dependent overcurrent protection (VOC51) algorithm.

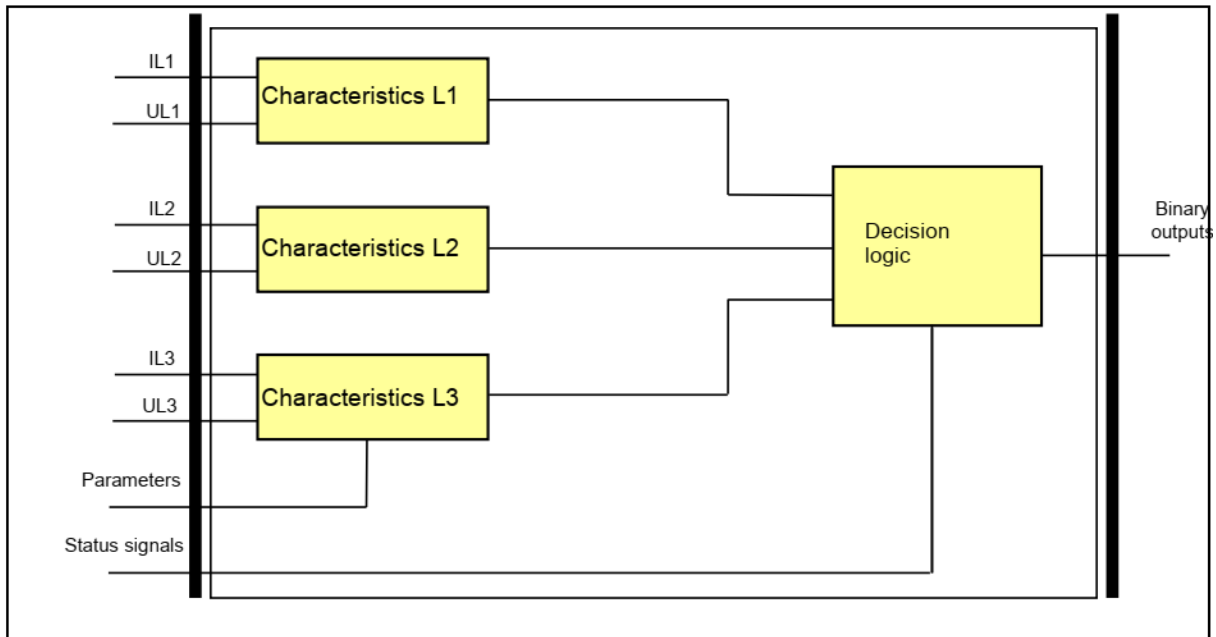

Figure 1-3 Structure of the voltage dependent overcurrent protection algorithm

The **inputs** are

- the sampled values of the three phase currents,
- the sampled values of the three phase (or calculated line-to-line) voltages,
- parameters,
- status signals.

The **outputs** are

- the binary output status signals.

The **software modules** of the overcurrent protection function:

Characteristics

This module

- calculates the current threshold value based on the Fourier components of the phase voltages;
- calculates required time delay based on the Fourier components of the phase currents;
- decides the generation of the starting signal in the individual phases;
- decides the generation of the trip command in the individual phases.

Decision logic

The decision logic module combines the status signals to generate the trip command of the function.

The signals and commands are generated only if neither the general blocking signal nor the blocking signal of the voltage transformer supervision function stops the operation.

The general start signal indicates the starting in any of the phases, the general trip command is generated if the current in any of the phases is above the calculated threshold value and the time delay expired.

2.1.23.2. Voltage dependent OC protection function overview

The graphic appearance of the function block of the voltage dependent overcurrent protection function is shown below. The block shows all binary input and output status signals which are applicable in the graphic logic editor.

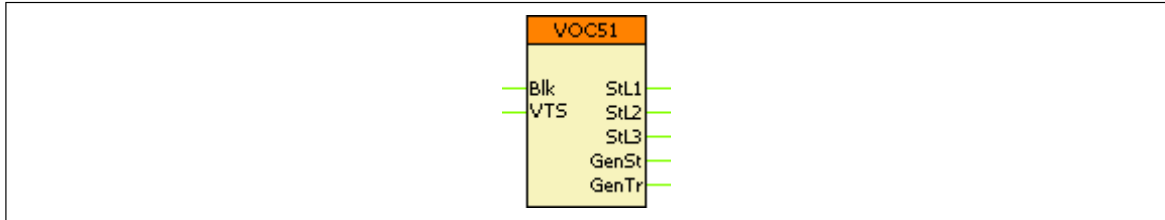

Figure 2-1 Graphic appearance of the function block

2.1.23.2.1. Settings

2.1.23.2.1.1. Parameters

The available parameters are listed below in order of their appearance in the *parameters* menu. If the setting range of a parameter should be extended, contact Protecta Support.

Table 2-1 Parameters of the voltage dependent overcurrent protection

TITLE	DIM	RANGE	STEP	DEFAULT	EXPLANATION
Operation	-	Off, On	-	Off	Enabling the function
Restrain mode	-	Restrained, Controlled	-	Restrained	Selection between the two characteristics.
U Low Limit	%	20 – 60	1	30	In "Restrained" mode, the operating current is "Start current" * "Ik limit"/100 below this voltage. In "Controlled" mode, the operation is blocked if the voltage is above this setting
U High Limit	%	60 – 110	1	80	In "Restrained" mode, the Operating current is "Start current" above this voltage. In "Controlled" mode, this parameter is not relevant.
Ik Limit	%	20 – 60	1	30	In "Restrained" mode, the operating current is "Start Current"*"Ik limit"/100 below "U Low Limit" In "Controlled" mode, this parameter is not relevant.
Start Current	%	20 – 3000	1	200	In "Restrained" mode, this is the starting current if the voltage is above "U High Limit". In "Controlled" mode, this is the starting current of the function if the voltage is below "U Low Limit"
Time Delay	msec	40 – 60000	1	100	Definite time delay

2.1.23.2.2. Function I/O

This section describes briefly the analogue and digital inputs and outputs of the function block.

2.1.23.2.2.1. Analogue inputs

The analogue inputs are:

- the sampled values of the three phase currents, and
- the sampled values of the three phase (or calculated line-to-line) voltages

2.1.23.2.2.2. Binary input signals (graphed output statuses)

The conditions of the binary inputs are defined by the user, applying the graphic equation editor (*Logic Editor*). Parts written in **bold** are seen on the left side function block in the Logic editor.

Table 2-1 The binary input signals of the function

BINARY INPUT SIGNAL	EXPLANATION
VOC51_ Blk _GrO_	Blocking input of the function
VOC51_ VTS _GrO_	Blocking input for VT supervision

2.1.23.2.2.3. Binary output signals (graphed input statuses)

These signals can be used in EuroCAP to assign to LED, user LCD object etc. Parts written in **bold** are seen on the right side of the function block in the *Logic Editor*.

Table 2-2 The binary output signals of the function

BINARY OUTPUT SIGNAL	SIGNAL TITLE	EXPLANATION
VOC51_ StL1 _GrI_	Start L1	Starting of the function in phase L1
VOC51_ StL2 _GrI_	Start L2	Starting of the function in phase L2
VOC51_ StL3 _GrI_	Start L3	Starting of the function in phase L3
VOC51_ GenSt _GrI_	General Start	Starting of the function
VOC51_ GenTr _GrI_	General Trip	Trip command of the function

2.1.23.2.2.4. Online data

Visible values on the *online data* page.

Table 2-3 Online displayed data of the voltage dependent overcurrent protection function

SIGNAL TITLE	DIMENSION	EXPLANATION
Start L1	-	Start signal of phase L1
Trip L1	-	Trip signal of phase L1
Start L2	-	Start signal of phase L2
Trip L2	-	Trip signal of phase L2
Start L3	-	Start signal of phase L3
Trip L3	-	Trip signal of phase L3
General Start	-	General start signal of the function
General Trip	-	General trip command of the function

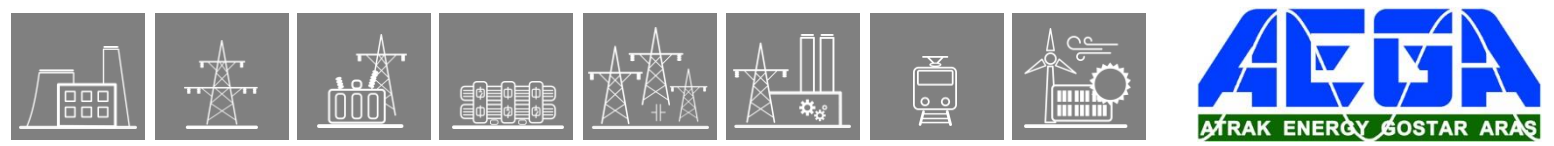

2.1.23.2.2.5. Events

The following events are generated in the event list, as well as sent to the SCADA according to the configuration.

Table 2-4 Generated events of the voltage dependent overcurrent protection function

EVENT	VALUE	EXPLANATION
General Start	off, on	General start of the function
Start L1	off, on	Start of function in phase L1
Start L2	off, on	Start of function in phase L2
Start L3	off, on	Start of function in phase L3
General Trip	off, on	General trip command of the function

2.1.23.2.3. Technical data

Table 2-5 Technical data of the function

FUNCTION	VALUE	ACCURACY
Operating accuracy	$20 \leq G_s \leq 1000$	< 2 %
Operate time accuracy		$\pm 5\%$ or ± 15 ms, whichever is greater
Reset ratio	0,95	
Reset time * Dependent time char. Definite time char.	Approx 60 ms	< 2% or ± 35 ms, whichever is greater
Transient overreach		< 2%
Pickup time *	< 40 ms	
Overshot time Dependent time char. Definite time char.	30 ms 50 ms	
Influence of time varying value of the input current (IEC 60255-151)	0.8	< 4%

* Measured with signal relay contact

2.1.23.2.4. Notes for testing

Normally in the EuroProt+ devices the trip contacts are assigned to the Trip Logic function block, and not to the protection function blocks. Because of this, the testing personnel must make sure that the Trip Logic is switched on ('Operation' parameter is set to other than 'Off') before starting the tests, otherwise there will be no physical trip on the relay.

Note that the time delay parameter incorporates the algorithm time as well, so the time delay **does not mean the time difference between the appearance of the start and trip signals** of the function. In other words: it is not the delay between the detection of the fault and the trip that follows it. This should be taken into consideration when checking the disturbance records.

Instead, the time delay parameter defines the elapsed time from the appearance of the faulty state to the trip. Because of this, while testing, the delay measurement should start *from the moment of the fault injection* until the trip signal.

As the analogue sources can be changed by the user, it is possible to assign the three phase or the three line-to-line voltages to the voltage inputs of the functionblock. This can be checked in the functionblock properties in EuroCAP.

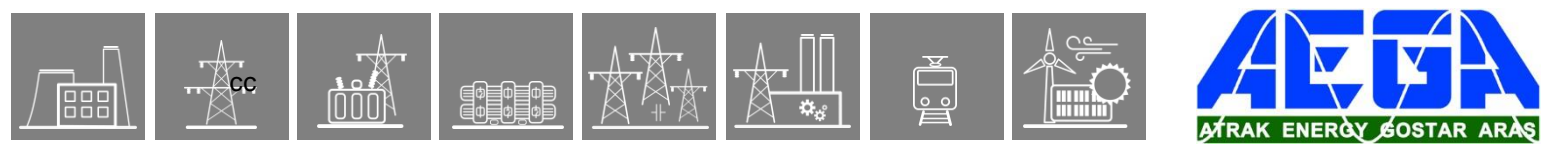

2.1.23.3. Application of the voltage dependent overcurrent protection function

The voltage dependent overcurrent protection function is mostly applied in generator protection systems as a backup protection function to faults that have not been cleared by the primary protection. These faults require generator disconnection to eliminate the fault.

The difficulty in application of simple overcurrent protection is that the fault current near to the generator is decaying in time, due to the sub-transient to transient to steady state reactance transition of the generator. Additionally, in case of generators with static excitation system, the generated e.m.f. is also decaying due to the dropped exciting voltage and current.

The backup protection must be coordinated to all other main and backup protections in the system, consequently the operating time is relatively long. During this long time the current gets below the rated current of the generator, i.e. below the possible operating level of an overcurrent protection of normal setting. The function resets, and the circuit breaker is not disconnected in spite of the sustained fault. To improve this behavior, the operation of the overcurrent function is restrained or controlled with voltage.

During the decay of the current the voltage also decays. The principle of the restrained voltage function is based on procedure that the starting current value gets adaptively lower if the measured voltage is below a setting level.

Usually, the sustained three-phase fault current is less than the maximum-load current, as long as the voltage regulator does not increase the sustained fault-reduced voltage. The voltage - controlled type prevents the overcurrent unit from operating until the fault reduces the voltage to a specific value, typically about 80% of normal. The voltage –restraint type changes the over-current pickup to decrease with decreasing voltage . Both allow the overcurrent unit to operate at current which is below the normal voltage of maximum load. Thus, sustained three-phase current below full load can be detected.

The voltage -controlled type with an adjustable fixed pickup, typically 50% of rated current, is easier to set and coordinate with other relays. On the other hand, the voltage-restraint type is less susceptible to unwanted operations on motor-starting currents and system swings. However, the short-time voltage depression caused by these probably would not result in the delayed over current operation.

The role of the voltage dependent overcurrent protection function is three-phase fault protection. The backup protection must provide protection for both phase faults and ground faults. For this purpose it is a usual solution that an additional negative-sequence overcurrent relay provides protection for unbalanced faults. The voltage dependent overcurrent protection function must be time-coordinated with any system relays it can overreach.

The overcurrent protection function realizes definite time characteristic based on three phase currents. The function has two modes of operation, depending on the parameter setting:

- Voltage controlled.
- Voltage restrained

In “Voltage controlled” mode the overcurrent function can operate only if the voltage is below the setting level.

In “Voltage restrained” mode the pick-up value of the overcurrent function changes with the voltage, according to the specified characteristic (see below).

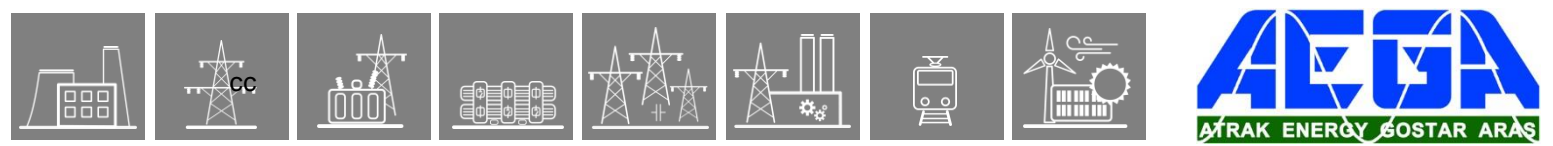

The function operates in three phases individually, but the generated general start signal and the general trip command is the OR relationship of the three decisions. In isolated systems (e.g. this is the usual neutral grounding method of the generator-transformer unit) the phase voltage is not as well defined as the line-to-line voltage. To improve the behavior, the phase current is pared to one of the line-to-line voltages, according to the Table below.

Current	Voltage
IL1	UL1-UL2
IL2	UL2-UL3
IL3	UL3-UL1

Table 1-1 Voltage and current assignment

The function can be blocked by a user-defined signal or by the voltage transformer supervision function block, if the measured voltage is not available.

Note: an alternative method to provide backup protection against external fault is the impedance protection. This protection function is advised if the backup protection is to be coordinated to line distance protection.

2.1.23.3.1. Basic parameter setting

2.1.23.3.1.1. Connection diagram

The voltage dependent overcurrent protection function can be connected alternatively to CTs at the terminal or at the neutral end. Voltage is from the generator terminal voltage transformers (VTs). It is used to prevent the time-overcurrent unit from operating, until a fault decreases the voltage.

The voltage inputs are connected to phase-to-neutral voltages. The connection diagram is shown in Figure 2-1.

Note1: for the correct operation of the voltage dependent overcurrent protection function, connect always Ph-N voltages to the voltage inputs. The Ph-Ph voltages, applied for the decision, are calculated internally.

Note2: The connection of the 3I₀ residual current is not needed for the voltage dependent overcurrent protection function. Connect this current, if other functions need it.

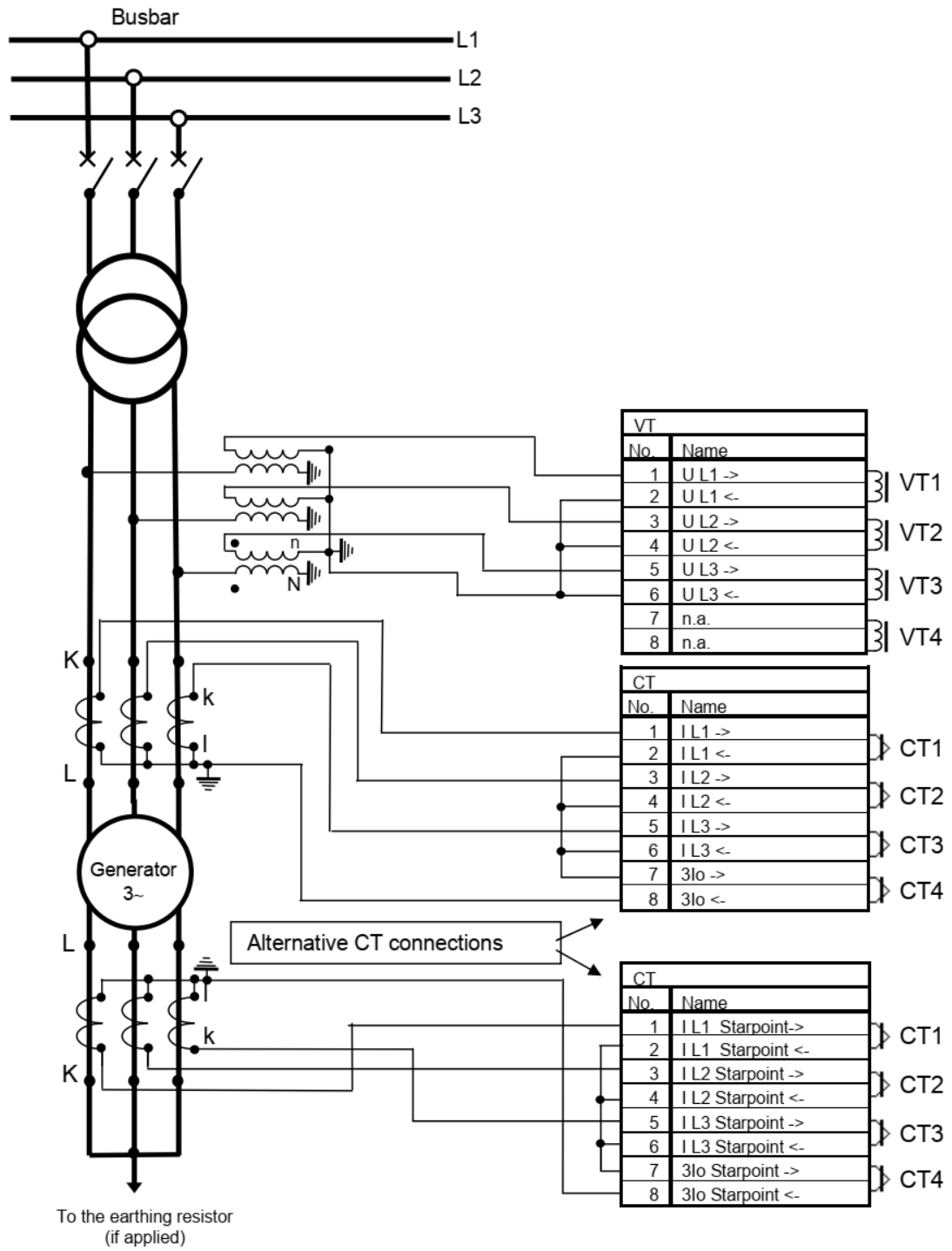

Figure 2-1 Connection diagram

2.1.23.3.1.2. Setting the parameters of the voltage input module

The corresponding parameter settings are explained in Table 2-1.

Parameter	Selection	Explanation
Range	Type 100	The type indicates the rated secondary voltage of the VT. This can be 100 V (in this example) or 200V. The displayed values in % are referring to this voltage.
Connection U1-3	Ph-N-Isolated	Connect always phase-to-neutral voltages to the inputs 1-3. Select "Ph-N-Isolated" as in case of earth-fault in not solidly grounded system, the Ph-N voltage can increase to Ph-Ph value. This selection is to provide optimal internal storage of the sampled voltage values.
Connection U4	n.a.	U4 input channel is not needed for the voltage dependent overcurrent protection function. Set it according to the requirements of other functions.
Direction U1-3	n.a.	The voltage dependent overcurrent protection function has no directionality, this parameter is not influencing the operation of the function. Set it according to the requirements of other functions.
Direction U4	n.a.	U4 input channel is not needed for the voltage dependent overcurrent protection function. Set it according to the requirements of other functions.
VT correction	100	This parameter is to correct the sampled values, if e.g. $U_{n_sec}=110V$ instead of 100V, set "VT correction = 110%".
Rated Primary U1-3	$15.75/\sqrt{3}$	Setting, according to the VT rated voltage, applied at the primary side. This parameter is used for scaling the displayed values only.
Rated Primary U4	n.a.	U4 input channel is not needed for the voltage dependent overcurrent protection function. Set it according to the requirements of other functions.

Table 2-1 Example parameters for the voltage input function

2.1.23.3.1.3. Setting the parameters of the current input module

Connect the phase currents according to Figure 2-1. The figure shows two alternative connection possibilities, select one of them. The voltage dependent overcurrent protection function has no directionality; this selection cannot influence the operation of the function.

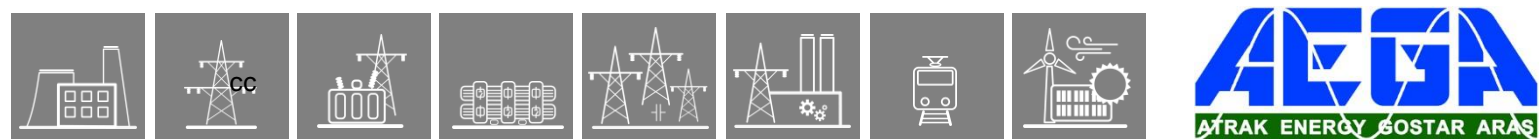

Parameter	Selection	Explanation
Rated secondary I1-3	Insec	Set the rated secondary current of the CT-s, e.g. 1A or 5A.
Rated secondary I4	n.a.	I4 input channel is not needed for the voltage dependent overcurrent protection function. Set it according to the requirements of other functions.
Starpoint I1-3	n.a.	The voltage dependent overcurrent protection function has no directionality, this parameter is not influencing the operation of the function. Set it according to the requirements of other functions.
Direction I4	n.a.	I4 input channel is not needed for the voltage dependent overcurrent protection function. Set it according to the requirements of other functions.
Rated Primary I1-3	Inprim	Setting, according to the CT rated current, applied at the primary side. This parameter is used for scaling the displayed values only.
Rated Primary I4	n.a.	I4 input channel is not needed for the voltage dependent overcurrent protection function. Set it according to the requirements of other functions.

Table 2-2 Example parameters for the current input function

2.1.23.3.2. Parameter setting for the operating characteristics

2.1.23.3.2.1. Selection of the voltage dependent characteristics

The function is basically a definite time overcurrent protection function, but the current pickup value is influenced by the measured voltage.

The function has two modes of operation, depending on the parameter setting:

- Voltage controlled (parameter “Restraining Mode” is set to “Controlled”),
- Voltage restrained (parameter “Restraining Mode” is set to “Restrained”).

The choice depends upon the power system characteristics and level of protection to be provided. The operating modes are explained below. Select one of them, according to the protection requirements.

2.1.23.3.2.1.1. Voltage controlled characteristics

In this case the overcurrent protection operates only if the voltage is below the “U_lowlimit” value and the current is above the “StartCurrent” value. (No operation is expected if the voltage is above the U_lowlimit” value.)

The pick-up current is the constant “StartCurrent” value (definite time overcurrent characteristic). The voltage controlled characteristic is shown in Figure 3-1.

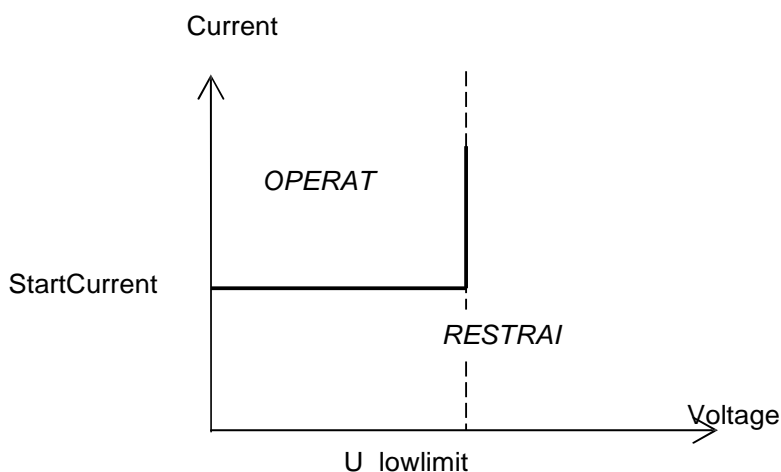

Figure 3-1 Voltage controlled characteristic

If voltage controlled characteristic is selected, consider the following setting criteria:

- The “U_lowlimit” voltage setting value should be below the minimal generator terminal voltage, expected in planned normal modes of operation (when the reactive power is delivered to the generator). At the same time the U_lowlimit voltage setting value should be above the maximum voltage, measured in three-phase fault condition, if the fault is located at the far end of the backup zone. Note: when calculating this voltage, consider the additional parallel power supply to this fault.
- The “StartCurrent” setting value should be below the minimum current, calculated for the end of the time span, when this function is expected to operate as a back-up protection. When calculating this current, consider the sub-transient to transient to steady state transition of the current, the decrement of the exciting voltage in case of static excitation system and the possible interaction of the voltage controller.
- The “U_highlimit” parameter has no role in this mode of operation.
- The “Ik_limit” parameter has no role in this mode of operation.
- The “Time Delay” parameter serves coordination with other protection devices and/or functions, protecting against external faults. Set this value for longer time delay than the expected trip time, when the main protection functions for these faults operate. The voltage dependent overcurrent protection function is designed to provide backup protection for these functions.

Table 3-1 is the summary of the parameters for voltage controlled mode of operation.

Parameter	Selection	Explanation
Operation	On	Enable the operation of the voltage dependent overcurrent protection function by setting this parameter to “On”
Restraining Mode	Controlled	The considerations above and the explanation in this Table are valid for this selection.
StartCurrent	calculate	The setting value should be based on calculation and experiences, as it is explained above
U_lowlimit	calculate	The setting value should be based on calculation and experiences, as it is explained above
U_highlimit	n.a.	This parameter is not applied in this mode of operation
Ik_limit	n.a.	This parameter is not applied in this mode of operation
Time Delay	coordinate	Set this parameter according to the time coordination, as it is explained above.

Table 3-1 Parameters for the voltage controlled mode of operation

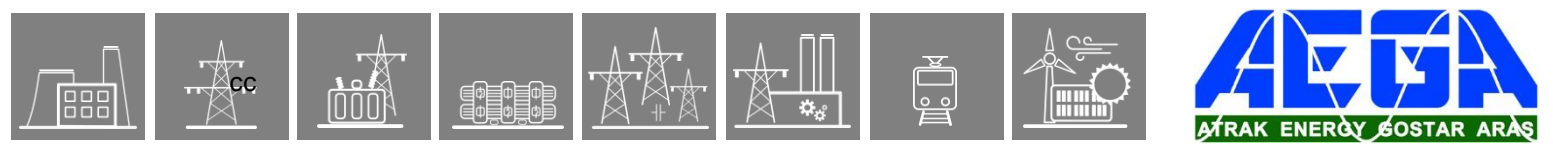

2.1.23.3.2.1.2. Voltage restrained characteristics

In this case the algorithm dynamically changes the threshold value of the current, based on the measured phase voltages at the generator terminals:

- Above the "U_Highlimit" value the function operates if the current is above the "StartCurrent" value.
- If the voltage is below the "U_lowlimit" value then the characteristic is lowered automatically to the "StartCurrent*I_{k_limit}/100".
- Between the two voltages the pick-up current value is increasing along a straight line.

The voltage restrained characteristic is shown in Figure 3-2.

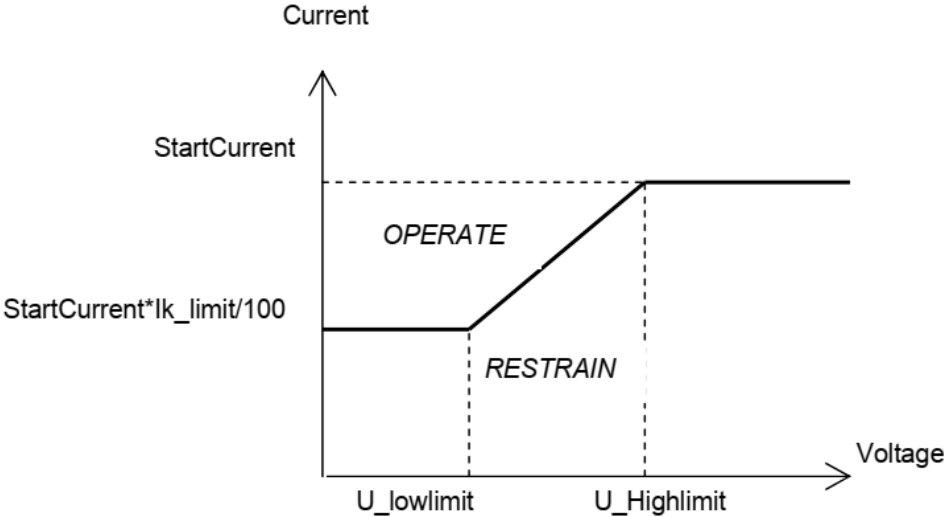

Figure 3-2 Voltage restrained characteristic

The voltage restrained characteristic allows special setting, when $U_lowlimit = U_highlimit$. The characteristic for this special choice is shown in Figure 3-3.

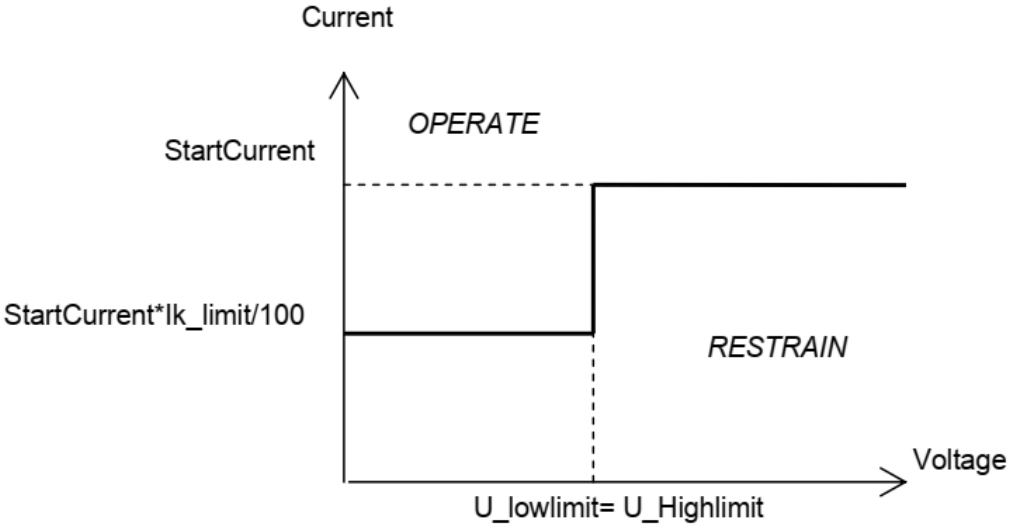

Figure 3-3 Special setting for the voltage restrained characteristic

Note: In case of incorrect setting, i.e. if $U_lowlimit$ is set higher than $U_highlimit$, the function is not operable. If the operator tries to download this wrong setting to the device, then the green operation LED indicator on the front side of the device turns to yellow, and the Internet browser screen of the connected computer shows the following warning symbol:



Correct for $U_{lowlimit} \leq U_{highlimit}$, and download the parameters again to leave the blocked state of the device and to return in normal operating mode.

The role of voltage restrained characteristic is to keep the started state of the protection function, even if the current decreases below the “StartCurrent” setting value. If t restrained mode is selected, consider the following setting criteria:

- The “U_highlimit” parameter setting value should be below the minimal generator terminal voltage, expected in planned normal modes of operation (when the reactive power is delivered to the generator).
- The U_lowlimit voltage setting value should be above the maximum voltage, measured in three-phase fault condition, if the fault is located at the far end of the backup zone. Note: when calculating this voltage, consider the additional parallel power supply to this fault.
- The “StartCurrent” setting value should be above the maximum load current of the generator. The usual overcurrent factor for the calculation is 1.5
- The “Ik_limit” parameter is a multiplication factor (in%) to multiply “StartCurrent”. It sets the current threshold below the minimum current, calculated for the end of the time span, when this function is expected to operate as a back-up protection. When calculating this current, consider the sub-transient to transient to steady state transition of the current, the decrement of the exciting voltage in case of static excitation system and the possible interaction of the voltage controller. It will generally be set below the generator fault current level as determined by synchronous reactance (Xs).
- The “Time Delay” parameter serves coordination with other protection devices and/or functions. Set this value for longer time delay then the expected trip time, when the main protection functions operate. The voltage dependent overcurrent protection function is designed to provide backup protection for these functions. It must be coordinated with the longest clearing time, for any of the transmission backup protection including breaker failure. A time margin of 0.5 seconds is recommended. This parameter value should also be checked for the following criteria: considering the decaying current and voltage during the operating time, the delivered extra power to the external fault may not overheat the generator.

Table 3-2 is the summary of the parameters for voltage restrained mode of operation.

Parameter	Selection	Explanation
Operation	On	Enable the operation of the voltage dependent overcurrent protection function by setting this parameter to “On”
Restrained Mode	Restrained	The considerations above and the explanation in this Table are valid for this selection.
StartCurrent	calculate	The setting value should be based on calculation and experiences, as it is explained above
U_lowlimit	calculate	The setting value should be based on calculation and experiences, as it is explained above
U_highlimit	calculate	The setting value should be based on calculation and experiences. This parameter value may not be below the U_lowlimit setting value
Ik_limit	calculate	The setting value should be based on calculation and experiences, as it is explained above
Time Delay	coordinate	Set this parameter according to the time coordination, as it is explained above.

Table 3-2 Parameters for the voltage restrained mode of operation

2.1.24.4. Structure of the definite time overvoltage protection algorithm

Fig.1-2 shows the structure of the definite time overvoltage protection (TOV59) algorithm.

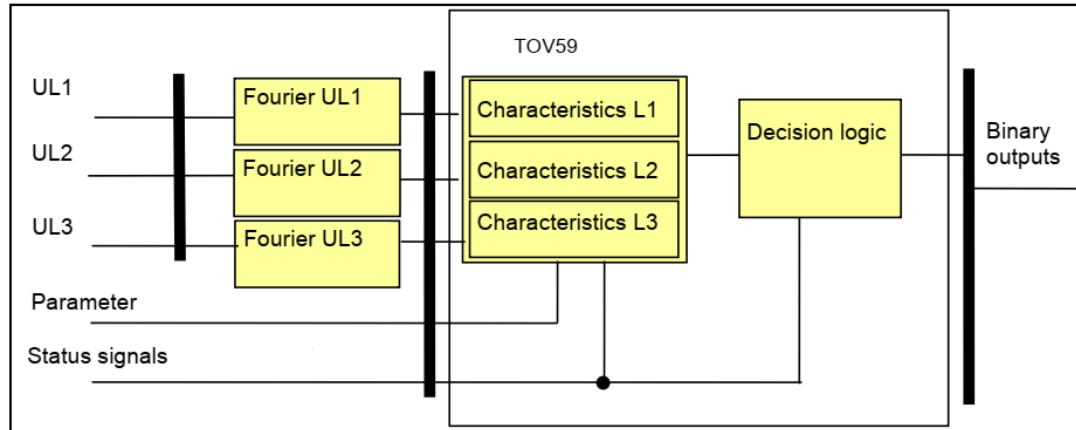

Figure 1-2 Structure of the definite time overvoltage protection algorithm

The **inputs** are

- the RMS values of the fundamental Fourier component of three phase voltages,
- parameters,
- status signals.

The **outputs** are

- the binary output status signals.

The **software modules** of the definite time overvoltage protection function:

Fourier calculations

These modules calculate the basic Fourier components of the phase voltages individually (not part of the TOV59 function). In medium voltage applications these are changed to phase-to-phase voltages.

Characteristics

This module calculates the required time delay based on the Fourier components of the phase (or phase-to-phase) voltages.

Decision logic

The decision logic module combines the status signals to generate the trip command of the function.

The following description explains the details of the individual components.

2.1.24.5. The Fourier calculation (Fourier)

These modules calculate the basic Fourier components of the phase voltages individually. They are not part of the TOV59 function; they belong to the preparatory phase.

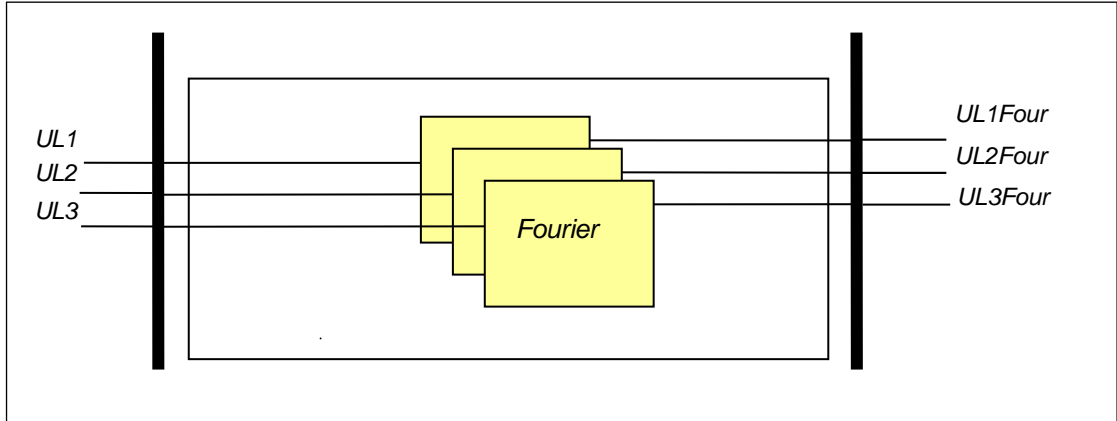
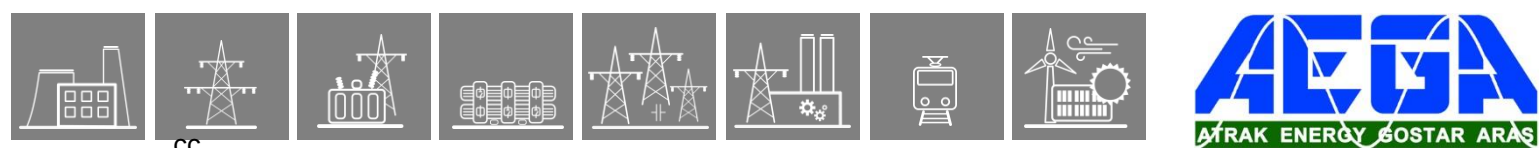

Figure 1-3 Schema of the Fourier calculation

The **inputs** are the sampled values of the three phase voltages (UL1, UL2, UL3)

The **outputs** are the RMS values of the basic Fourier components of the analyzed voltages (UL1Four, UL2Four, UL3Four).

The phase-to-phase voltages (if used) are also calculated here.



CC

Boolean parameter

Parameter name	Title	Default	Explanation
TOV59_StOnly_BPar_	Start Signal Only	0	Selection if starting and trip signal or starting signal only is to be generated. Set 0 for trip command generation.

Table 1-4 The Boolean parameters of the overvoltage protection function

Timer parameter

Parameter name	Title	Unit	Min	Max	Step	Default
Time delay of the overvoltage protection function.						
TOV59_Delay_TPar_	Time Delay	ms	0	60000	1	100

Table 1-5 The timer parameter of the overvoltage protection function

The **binary output status signals** of the three-phase definite time overvoltage protection function are listed in . *In case of phase-to-phase voltages, these are changed to L12, L23, L31 respectively.

**The trip signals are not published for the phases individually

Table 1-6 below.

Binary output status signal	Signal title	Explanation
TOV59_StL1_Grl_	StL1	Starting of the function in phase L1*
TOV59_TrL1_Grl_	TrL1**	Trip command of the function in phase L1*
TOV59_StL2_Grl_	StL2	Starting of the function in phase L2*
TOV59_TrL2_Grl_	TrL2**	Trip command of the function in phase L2*
TOV59_StL3_Grl_	StL3	Starting of the function in phase L3*
TOV59_TrL3_Grl_	TrL3**	Trip command of the function in phase L3*

*In case of phase-to-phase voltages, these are changed to L12, L23, L31 respectively.

**The trip signals are not published for the phases individually

Table 1-6 The binary output status signals of the definite time overvoltage protection function

2.1.24.7. The decision logic (Decision logic)

The decision logic module combines binary signals and Boolean parameters to generate the trip command of the function.

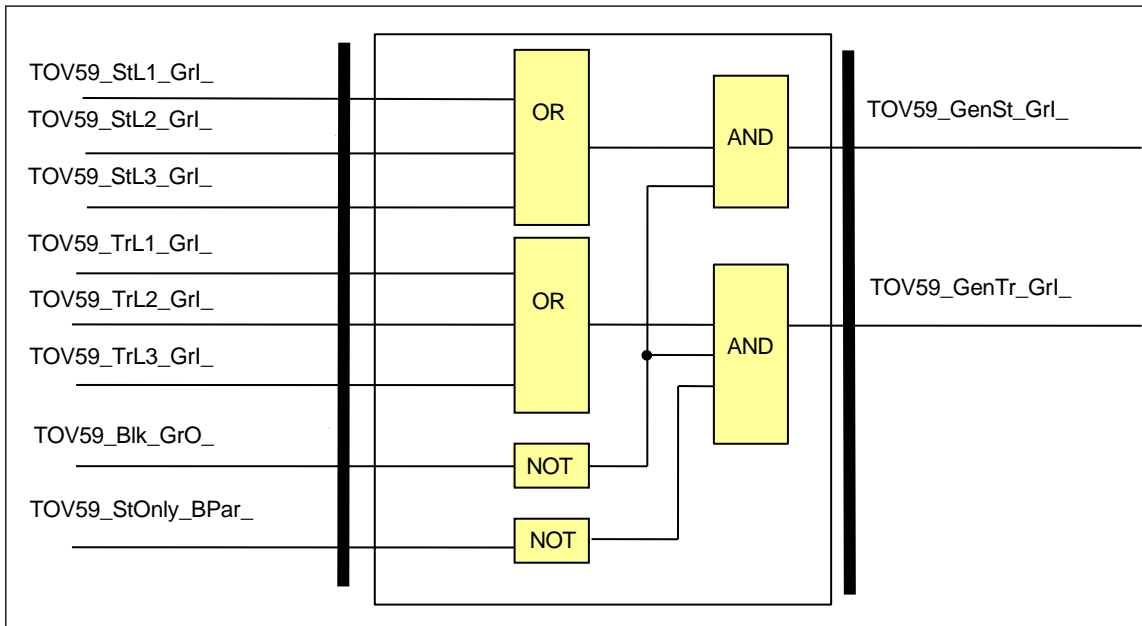

Figure 1-5 The decision logic scheme of the definite time overvoltage protection function

Binary input signal	Signal title	Explanation
TOV59_StL1_Grl_	StL1	Starting of the function in phase L1*
TOV59_TrL1_Grl_	TrL1**	Trip command of the function in phase L1*
TOV59_StL2_Grl_	StL2	Starting of the function in phase L2*
TOV59_TrL2_Grl_	TrL2**	Trip command of the function in phase L2*
TOV59_StL3_Grl_	StL3	Starting of the function in phase L3*
TOV59_TrL3_Grl_	TrL3**	Trip command of the function in phase L3*

*In case of phase-to-phase voltages, these are changed to L12, L23, L31 respectively.

**The trip signals are not published for the phases individually

Table 1-7 The binary input signals of the definite time overvoltage protection function

Boolean parameter

Parameter name	Title	Default
Enabling start signal only:		
TOV59_StOnly_BPar_	Start Signal Only	FALSE

Table 1-8 The Boolean parameter of the definite time overvoltage protection function

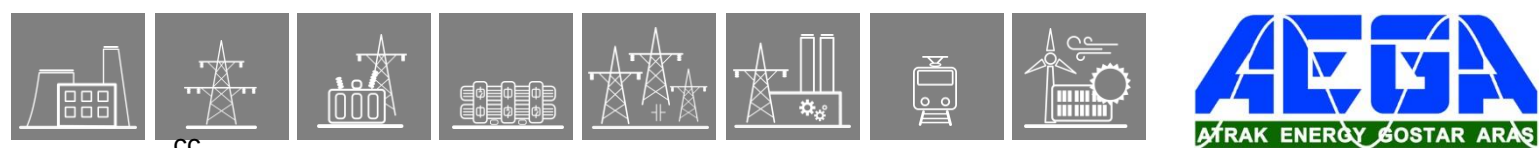

CC

Binary status signals

The overvoltage protection function has a binary input signal, which serves the purpose of disabling the function. The conditions of disabling are defined by the user, applying the graphic equation editor.

Binary input status signal	Explanation
TOV59_BlK_GrO_	Output status of a graphic equation defined by the user to disable the definite time overvoltage protection function.

Table 1-9 The binary input signal of the definite time overvoltage protection function

Binary output status signal	Title	Explanation
TOV59_StL1_Grl_	StL1	Start in phase L1*
TOV59_StL2_Grl_	StL2	Start in phase L2*
TOV59_StL3_Grl_	StL3	Start in phase L3*
TOV59_GenSt_Grl_	GenSt	General start signal
TOV59_GenTr_Grl_	GenTr	General trip command

*In case of phase-to-phase voltages, these are changed to L12, L23, L31 respectively.

Table 1-10 The binary output status signals of the definite time overvoltage protection function

2.1.24.8.3. Binary output status signals

The **binary output status signals** of overvoltage protection function are listed in Table 1-12
 The binary output status signals of the overvoltage protection function

Binary status signal	Title	Explanation
TOV59_StL1_GrI_	StL1	Start in phase L1
TOV59_StL2_GrI_	StL2	Start in phase L2
TOV59_StL3_GrI_	StL3	Start in phase L3
TOV59_GenSt_GrI_	GenSt	General start signal
TOV59_GenTr_GrI_	GenTr	General trip command

Table 1-12 The binary output status signals of the overvoltage protection function

2.1.24.8.4. Binary input status signals

Binary input signals

The overvoltage protection function has a binary input signal, which serves the purpose of disabling the function. **The conditions of disabling are defined by the user, applying the graphic equation editor.**

Binary status signal	Title	Explanation
TOV59_BlK_GrO_	Blk	Blocking of the overvoltage protection function

Table 1-13 The binary input signal of the overvoltage protection function

2.1.24.8.5. The function block

The function block of the overvoltage protection function is shown in Figure 1-6. This block shows all binary input and output status signals that are applicable in the graphic equation editor.

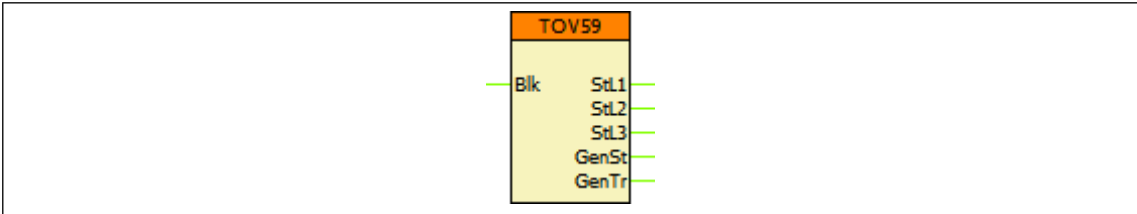

Figure 1-6 The function block of the overvoltage protection function

2.1.25.3. The Fourier calculation (Fourier)

This module calculates the RMS value of the fundamental Fourier component of the residual or neutral voltage ($U_N=3U_0$). This module is not part of the TOV59N function; it belongs to the preparatory phase.

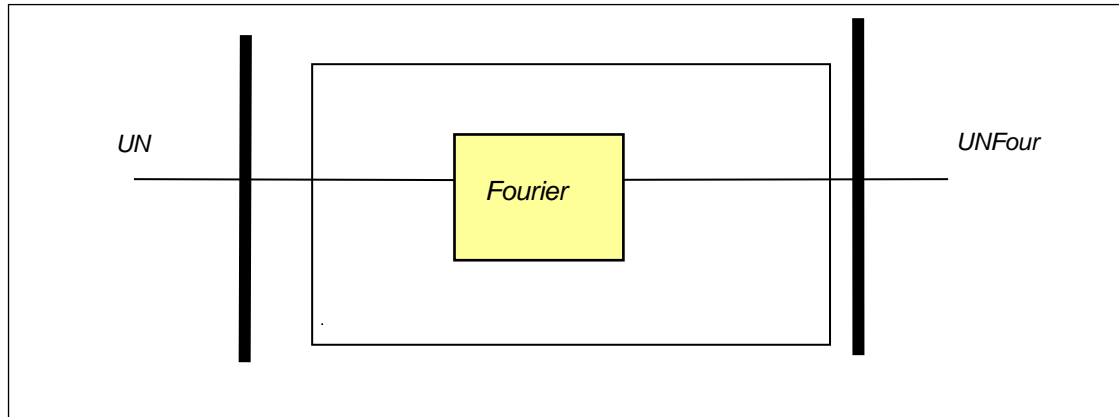

Figure 1-3 Schema of the Fourier calculation

The **input** is the sampled value of the residual voltage ($U_N=3U_0$).

The **output** is the RMS value of the fundamental Fourier component of the residual or neutral voltage (U_{NFour}).

2.1.25.4. The definite time characteristics (Characteristics)

This module decides the starting of the function and counts the required time delay based on the Fourier components of the residual voltage. The time delay is defined by the parameter setting value, if the voltage is above the voltage setting value.

The **inputs** are:

- the RMS value of the fundamental Fourier component of the residual or neutral voltage (U_{NFour}),
- parameters.

The **outputs** are the status signals of the function. These indicate the started state of the function.

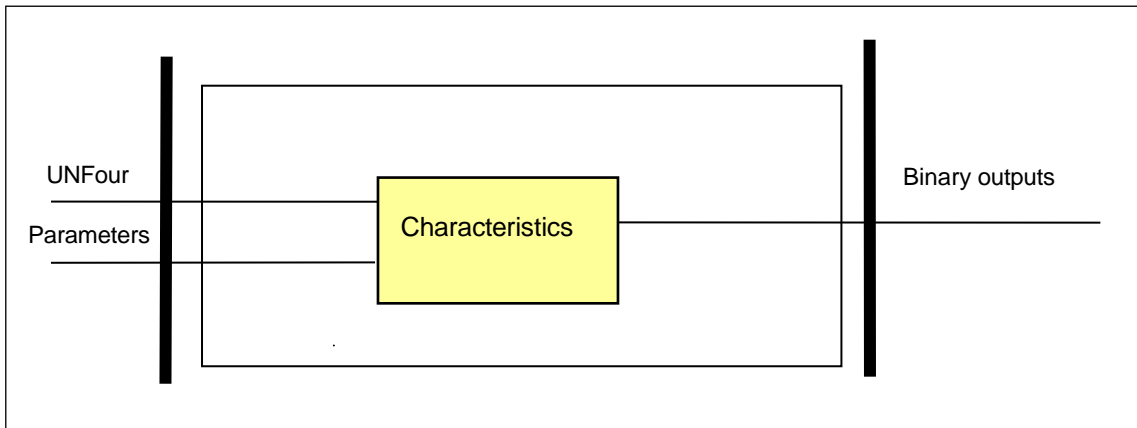

Figure 1-4 Schema of the residual definite time characteristic calculation

Enumerated parameter

Parameter name	Title	Selection range	Default
Parameter for enabling/disabling the function			
TOV59N_Oper_EPar_	Operation	Off, On	On

Table 1-1 The enumerated parameters of the residual definite time overvoltage protection function

Integer parameter

Parameter name	Title	Unit	Min	Max	Step	Default
Starting voltage parameter:						
TOV59N_StVol_IPar_	Start Voltage	%	2	60	1	30

Table 1-2 The integer parameters of the residual definite time overvoltage protection function

Timer parameter

Parameter name	Title	Unit	Min	Max	Step	Default
Definite time delay:						
TOV59N_Delay_TPar_	Time Delay	msec	0	60000	1	100

Table 1-3 Timer parameter of the residual definite time overvoltage protection function

The **binary output status signals** of the residual definite time overvoltage protection function are listed in Table 1-4.

Binary output signals	Signal title	Explanation
TOV59N_St_Grl_	Start L1	Starting of the function
TOV59N_Tr_Grl_	Trip L1	Trip command of the function

Table 1-4 The binary output status signals of the residual definite time overvoltage protection function

2.1.25.5. The decision logic (Decision logic)

The decision logic module combines the status signals, binary and enumerated parameters to generate the trip command of the function.

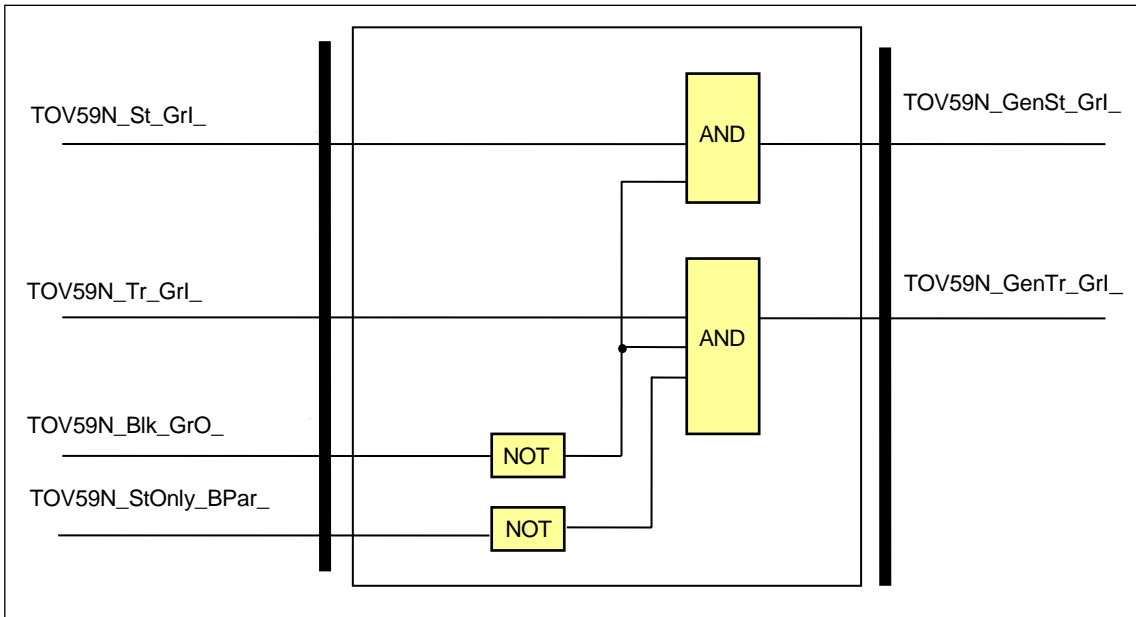

Figure 1-5 The logic scheme of the residual definite time overvoltage protection function

Binary input signals	Signal title	Explanation
TOV59N_St_GrI_	Start L1	Starting of the function
TOV59N_Tr_GrI_	Trip L1	Trip command of the function

Table 1-5 The binary input status signals of the decision logic scheme for the residual definite time overvoltage protection function

Boolean parameter

Parameter name	Title	Default
Enabling start signal only:		
TOV59N_StOnly_BPar_	Start Signal Only	FALSE

Table 1-6 The Boolean parameter of the residual definite time overvoltage protection function



Binary status signals

The overvoltage protection function has a binary input signal, which serves the purpose of disabling the function. **The conditions of disabling are defined by the user, applying the graphic equation editor.**

Binary status signal	Explanation
TOV59N_Blk_GrO_	Output status of a graphic equation defined by the user to disable the residual definite time overvoltage protection function.

Table 1-7 The binary input signal of the residual definite time overvoltage protection function

Binary output signals	Signal title	Explanation
TOV59N_GenSt_Grl_	General Start	General starting of the function
TOV59N_GenTr_Grl_	General Trip	General trip command of the function

Table 1-8 The binary output status signals of the residual definite time overvoltage protection function

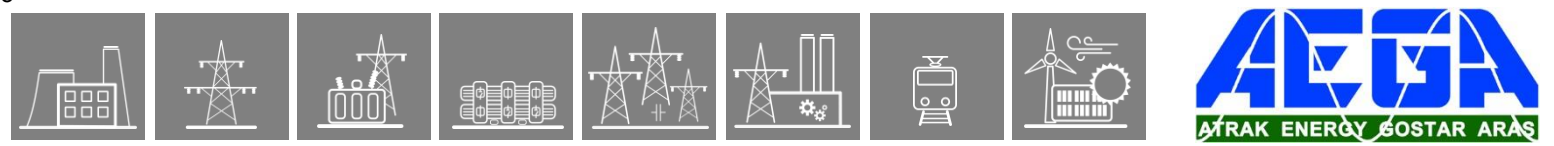

2.1.26. Residual start-up overvoltage protection function

During the start-up of a gas turbine, the frequency is far below the rated value for a relatively long time. The conventional measuring algorithms – RMS calculation, Fourier analysis, etc. - are not designed to perform measurement if the frequency is out of the operating range.

This protection function is designed as a residual definite time overvoltage protection function, using the peak-to-peak value of the residual voltage ($UN=3U_0$) in broad frequency range.

In this protection function the exciting state of the generator is not considered; the setting value of the characteristic quantity is constant. See also Protecta document “Overexcitation protection function” if the exciting state is to be considered.

2.1.26.1. Operation principle

2.1.26.1.1. Operating characteristics

This function operates according to definite time characteristics:

$$t(G) = t_{OP} \text{ when } G > G_s$$

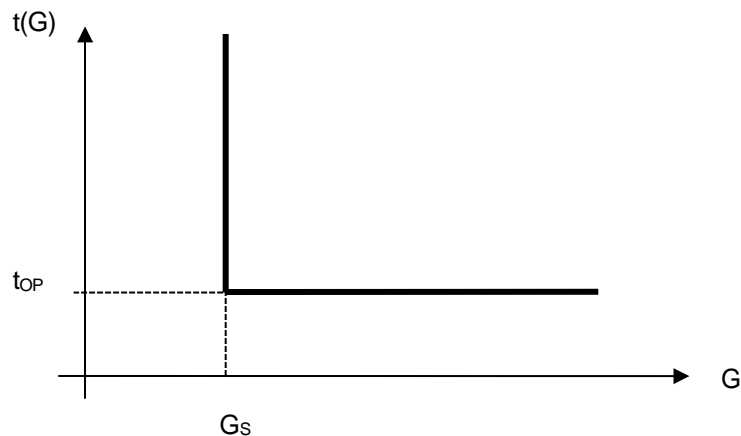

Figure 1-1 Overvoltage independent time characteristic

where

t_{OP} (seconds)	theoretical operating time if $G > G_s$, fix, according to the parameter setting value (Time delay),
G	measured value of the characteristic quantity, peak-to-peak value of the residual voltage,
G_s	setting value of the characteristic quantity (Start voltage).

2.1.26.1.2. Structure of the residual definite time overvoltage protection algorithm for start-up application

The figure below shows the structure of the residual definite time overvoltage protection (TOV59NS) algorithm for start-up application.

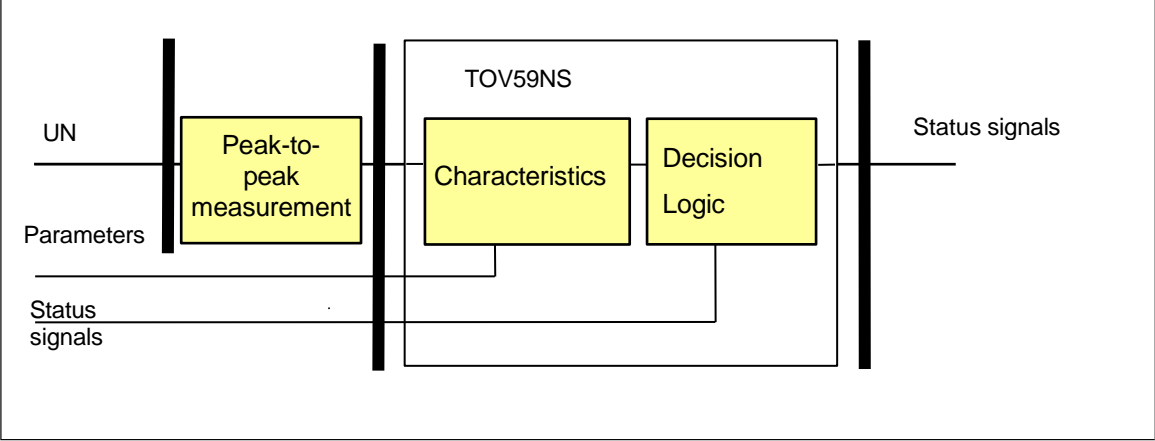

Figure 1-2 Structure of the definite time residual overvoltage protection algorithm for start-up application

The **inputs** are

- the peak-to-peak value of the residual or neutral voltage ($UN=3U_0$),
- parameters,
- status signals.

The **outputs** are

- the binary output status signals.

The **software modules** of the differential protection function:

Peak-to-peak measurement

These modules calculate the peak-to-peak value of the residual voltage (not part of the TOV59NS function).

Characteristics

This module calculates the required time delay based on the peak-to-peak value of the residual voltage.

Decision logic

The decision logic module combines the status signals to generate the trip command of the function.

The following description explains the details of the individual components.

2.1.26.1.3. The peak-to-peak measurement

This module calculates the peak-to-peak value of the residual or neutral voltage ($UN=3U_0$). This module is not part of the TOV59NS function; it belongs to the preparatory phase.

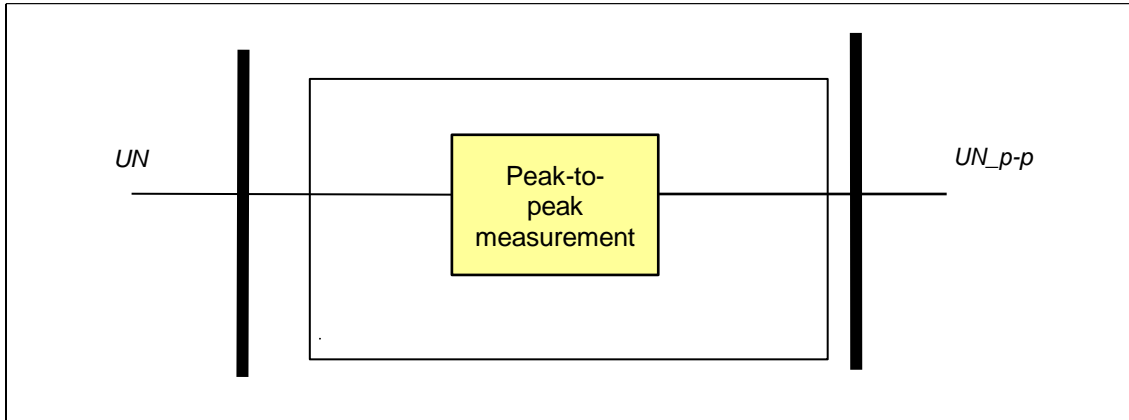

Figure 1-3 Schema of the peak-to-peak measurement

The **input** is the sampled value of the residual voltage ($UN=3U_0$).

The **output** is the peak-to-peak value of the residual or neutral voltage (UN_{p-p}).

NOTE: the scaling corresponds to the RMS value of a sinusoid.

2.1.26.1.4. The definite time characteristics (Characteristics)

This module decides the starting of the function and counts the required time delay based on the peak-to-peak value of the residual voltage. The time delay is defined by the parameter setting value, if the voltage is above the voltage setting value.

The **inputs** are:

- the peak-to-peak value of the residual or neutral voltage (UN_{p-p}),
- parameters.

The **outputs** are the status signals of the function. These indicate the started state and the trip command of the function.

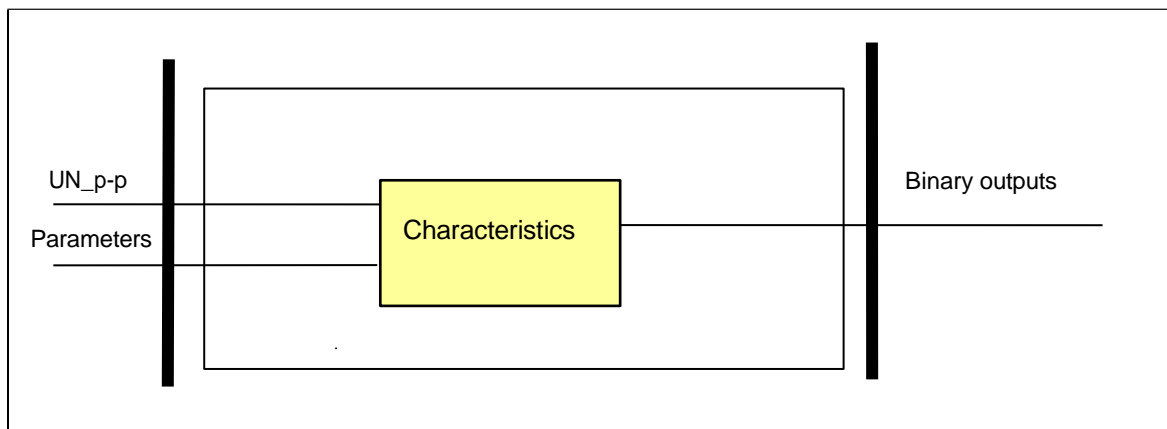
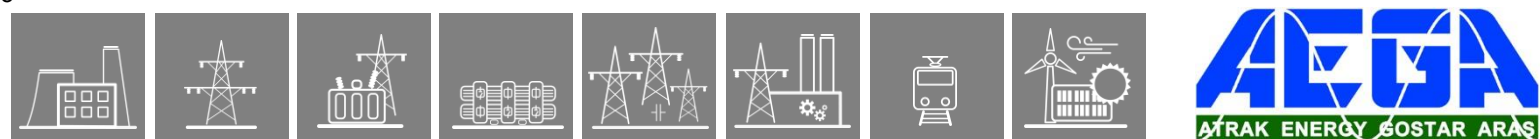

Figure 1-4 Schema of the definite time characteristic calculation



Enumerated parameter

Table 1-1 Enumerated parameter of the residual definite time overvoltage protection function for start-up application

PARAMETER NAME	TITLE	SELECTION RANGE	DEFAULT
Parameter for enabling/disabling the function			
TOV59NS_Oper_EPar_	Operation	Off, On	On

Integer parameter

Table 1-2 Integer parameter of the residual definite time overvoltage protection function for start-up application

PARAMETER NAME	TITLE	UNIT	MIN	MAX	STEP	DEFAULT
Starting voltage (scaled as RMS value) parameter percent of the rated voltage of the voltage input module:						
TOV59NS_StVol_IPar_	Start Voltage	%	2	60	1	30

Timer parameter

Table 1-3 Timer parameter of the residual definite time overvoltage protection function for start-up application

PARAMETER NAME	TITLE	UNIT	MIN	MAX	STEP	DEFAULT
Definite time delay:						
TOV59NS_Delay_TPar_	Time Delay	msec	0	60000	1	100

The **binary output status signals** of the residual definite time overvoltage protection function for start-up application are listed in Table 1-4.

Table 1-4 The binary output status signals of the residual definite time overvoltage protection function for start-up application

BINARY OUTPUT SIGNALS	SIGNAL TITLE	EXPLANATION
TOV59NS_St_Grl_	Start	Starting of the function
TOV59NS_Tr_Grl_	Trip	Trip command of the function

2.1.26.2. Start-up overvoltage protection function overview

The graphic appearance of the function block of the start-up overvoltage protection function is shown below. The block shows all binary input and output status signals which are applicable in the graphic equation editor.

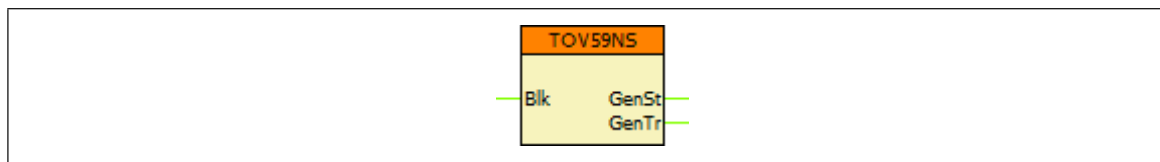

Figure 2-1 Graphic appearance of the function block of the inter-turn fault protection function

2.1.26.3. Settings

2.1.26.3.1. Parameters

The available parameters are listed below in order of their appearance in the *parameters* menu. If the setting range of a parameter should be extended, contact Protecta Support.

Table 2-1 Parameters of the inter-turn fault protection function

TITLE	DIM	RANGE	STEP	DEFAULT	EXPLANATION
Operation	-	Off, On	-	Off	Enabling the function
Start Signal Only	-	FALSE, TRUE	-	FALSE	Enabling start signal only
Start Voltage	%	2 – 60	1	30	Pickup setting value
Time Delay	msec	0 – 60000	1	200	Time delay (including the algorithm time, see Chapter 2.4 for more explanation)

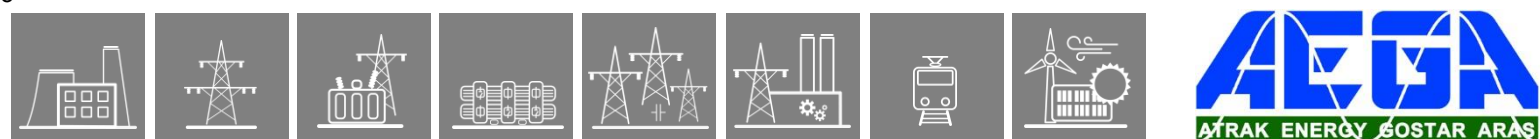

2.1.26.4. Function I/O

This section describes briefly the analogue and digital inputs and outputs of the function block.

2.1.26.4.1. Analogue inputs

The function uses the sampled values of the 4th voltage input on the VT module.

2.1.26.4.2. Binary input signals (graphed output statuses)

The conditions of the binary inputs are defined by the user, applying the graphic equation editor (*Logic Editor*). Parts written in **bold** are seen on the left side function block in the Logic editor.

Table 2-2 The binary input signal of the inter-turn fault protection function

BINARY OUTPUT SIGNAL	EXPLANATION
TOV59NS_ Blk _GrO_	Blocking input of the function

2.1.26.4.3. Binary output signals (graphed input statuses)

These signals can be used in EuroCAP to assign to LED, user LCD object etc. Parts written in **bold** are seen on the right side of the function block in the *Logic Editor*.

Table 2-3 The binary output signals of the inter-turn fault protection function

BINARY OUTPUT SIGNAL	SIGNAL TITLE	EXPLANATION
TOV59NS_ GenSt _GrI_	General Start	General start signal of the function
TOV59NS_ GenTr _GrI_	General Trip	General trip command of the function

2.1.26.4.4. Online data

Visible values on the *online data* page.

Table 2-4 Online displayed data of the inter-turn fault protection function

SIGNAL TITLE	DIMENSION	EXPLANATION
General Start	-	General start signal of the function
General Trip	-	General trip command of the function

2.1.26.4.5. Events

The following events are generated in the event list, as well as sent to the SCADA according to the configuration.

Table 2-5 Generated events of the inter-turn fault protection function

EVENT	VALUE	EXPLANATION
General Start	off, on	General start of the function
General Trip	off, on	General trip command of the function

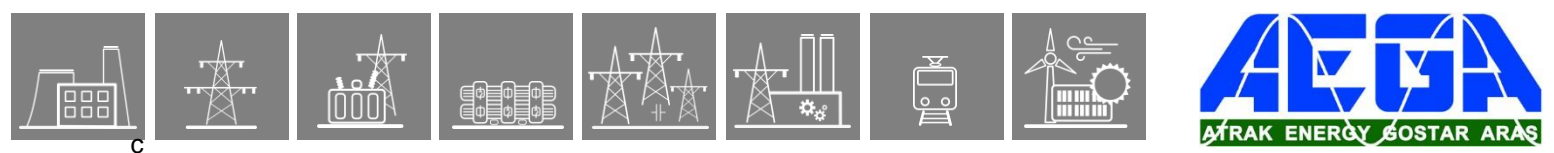

2.1.26.5. Technical data

Table 2-6 Technical data of the inter-turn fault protection function

FUNCTION	VALUE	ACCURACY
Effective frequency range	7-35Hz	
Effective voltage range	5-25%	
Pick-up starting accuracy	5-25%	< ± 5%
Operate time (frequency dependent)	2.5 periods	< ± 1 period
Reset time (frequency dependent)	3 periods	< ± 1 period

Determination of the above values is based on the following considerations:

- The function will be used in gas turbine applications, where the turbine will be started by the generator operating as a motor and supplied from a frequency converter. The purpose is to detect earth faults during startup in the low frequency range, where other functions are not effective. The function is only active during startup operation.
- Due to the limited voltage rating of the frequency converter, it is enough to examine voltage levels up to 25% of the generator rating.
- The starting converter does not drive the turbine up to rated speed. It can be switched off around two third of the rated speed, from where the turbine accelerates by itself. Therefore, the lowest operating frequency has been determined and frequencies up to 70% have been examined only.

2.1.26.6. Notes for testing

Normally in the EuroProt+ devices the trip contacts are assigned to the Trip Logic function block, and not to the protection function blocks. Because of this, the testing personnel must make sure that the Trip Logic is switched on ('Operation' parameter is set to other than 'Off') before starting the tests, otherwise there will be no physical trip on the relay.

Note that the time delay parameter incorporates the algorithm time as well, so the time delay does **not** mean the time difference between the appearance of the start and trip signals of the function. In other words: it is not the delay between the detection of the fault and the trip that follows it. This should be taken into consideration when checking the disturbance records.

Instead the time delay parameter defines the elapsed time from the appearance of the faulty state to the trip. Because of this, while testing, the delay measurement should start *from the moment of the fault injection* until the trip signal.

Note again that the function is only active during startup operation. Due to the limited voltage rating of the frequency converter used at the start of the generator, it is enough to examine voltage levels up to 25% of the generator rating.

2.1.27. Inter-turn fault protection function based on voltage measurement

In case of single-winding generators, a short-circuit between the turns of the stator winding cannot be detected by current-based protection functions, as there is no significant change in the current symmetry and magnitude. However, dangerous circulating current may flow between the shorted turns and damage the stator and its windings.

In order to detect such faulty operation, a special displacement voltage measurement shall be applied. The starpoint of the terminal side VT primary circuit shall be connected to the generator neutral. As a result, the open delta secondary winding can accurately detect voltage asymmetry between the phases and remain insensitive for earth faults.

Apart from the VT connection, the function block uses the same algorithm as the residual overvoltage protection, therefore the function block **TOV59N (Residual OverVoltage)** is utilized here. The difference lies within the analogue source. The algorithm will work according to definite time characteristics, using the RMS values of the fundamental Fourier component of the measured displacement voltage.

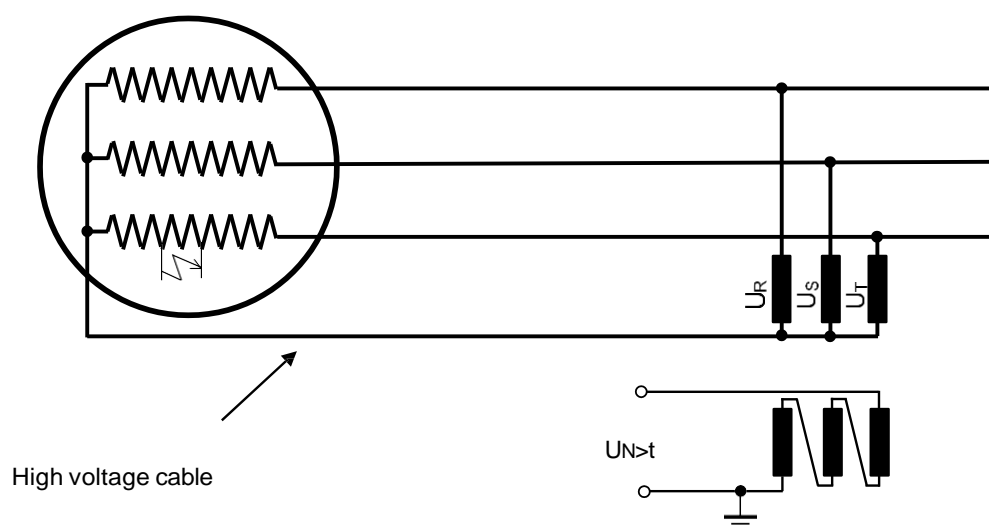
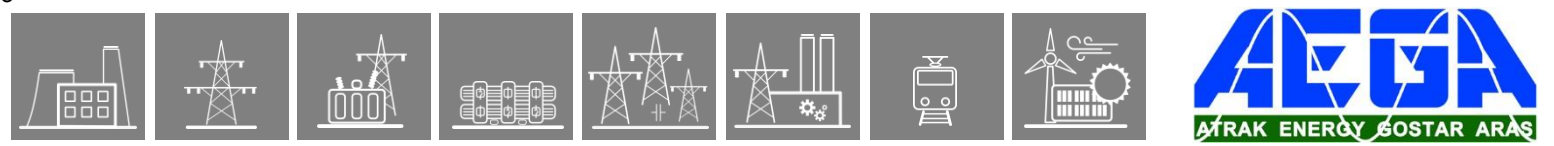

Figure 1-1 VT connection for the voltage based inter-turn fault protection



The **inputs** are

- the RMS values of the fundamental Fourier component of the inter-turn voltage,
- parameters,
- status signals.

The **outputs** are

- the binary output status signals.

The **software modules** of the voltage-based inter-turn fault protection function:

Fourier calculations

These modules calculate the basic Fourier components of the inter-turn voltage (not part of the TOV59N function).

Characteristics

This module calculates the required time delay based on the Fourier components of the inter-turn voltage.

Decision logic

The decision logic module combines the status signals to generate the trip command of the function.

The following description explains the details of the individual components.

2.1.27.1.3. The Fourier calculation (Fourier)

This module calculates the RMS value of the fundamental Fourier component of inter-turn voltage. This module is not part of the TOV59N function; it belongs to the preparatory phase.

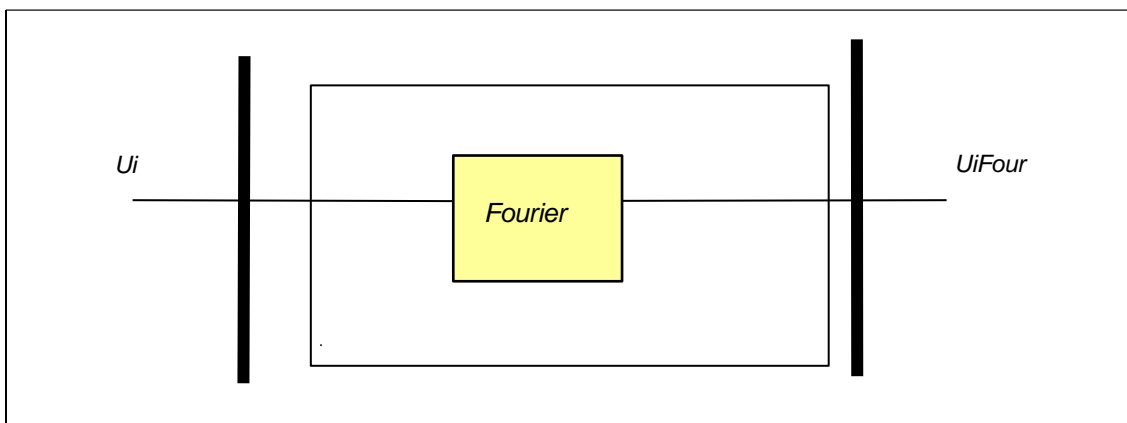

Figure 1-4 Schema of the Fourier calculation

The **input** is the sampled value of the inter-turn voltage (U_i).

The **output** is the RMS value of the fundamental Fourier component of the inter-turn voltage (U_{iFour}).

2.1.27.1.4. The definite time characteristics (Characteristics)

This module decides the starting of the function and counts the required time delay based on the Fourier components of the inter-turn voltage. The time delay is defined by the parameter setting value, if the voltage is above the voltage setting value.

The **inputs** are:

- the RMS value of the fundamental Fourier component of the inter-turn voltage (UiFour),
- parameters

The **outputs** are the status signals of the function. These indicate the started state of the function.

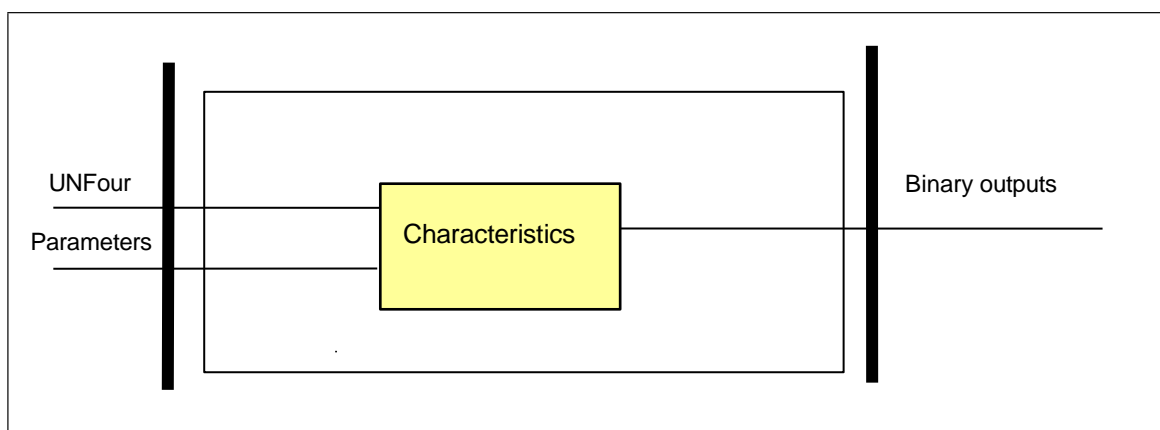

Figure 1-5 Schema of the definite time characteristic calculation

Enumerated parameter

Table 1-1 Enumerated parameter of the voltage based inter-turn fault protection function

PARAMETER NAME	TITLE	SELECTION RANGE	DEFAULT
Parameter for enabling/disabling the function			
TOV59N_Oper_EPar_	Operation	Off, On	On

Integer parameter

Table 1-2 Integer parameter of the voltage based inter-turn fault protection function

PARAMETER NAME	TITLE	UNIT	MIN	MAX	STEP	DEFAULT
Starting voltage parameter:						
TOV59N_StVol_IPar_	Start Voltage	%	2	60	1	30

Timer parameter

Table 1-3 Timer parameter of the voltage based inter-turn fault protection function

PARAMETER NAME	TITLE	UNIT	MIN	MAX	STEP	DEFAULT
Definite time delay:						
TOV59N_Delay_TPar_	Time Delay	msec	0	60000	1	100

The **binary output status signals** of the voltage based inter-turn fault protection function are listed in Table 1-4.

Table 1-4 The binary output status signals of the voltage based inter-turn fault protection function

BINARY OUTPUT SIGNALS	SIGNAL TITLE	EXPLANATION
TOV59N_St_GrI_	Start	Starting of the function
TOV59N_Tr_GrI_	Trip	Trip command of the function

2.1.27.1.5. The decision logic (Decision logic)

The decision logic module combines the status signals, binary and enumerated parameters to generate the trip command of the function.

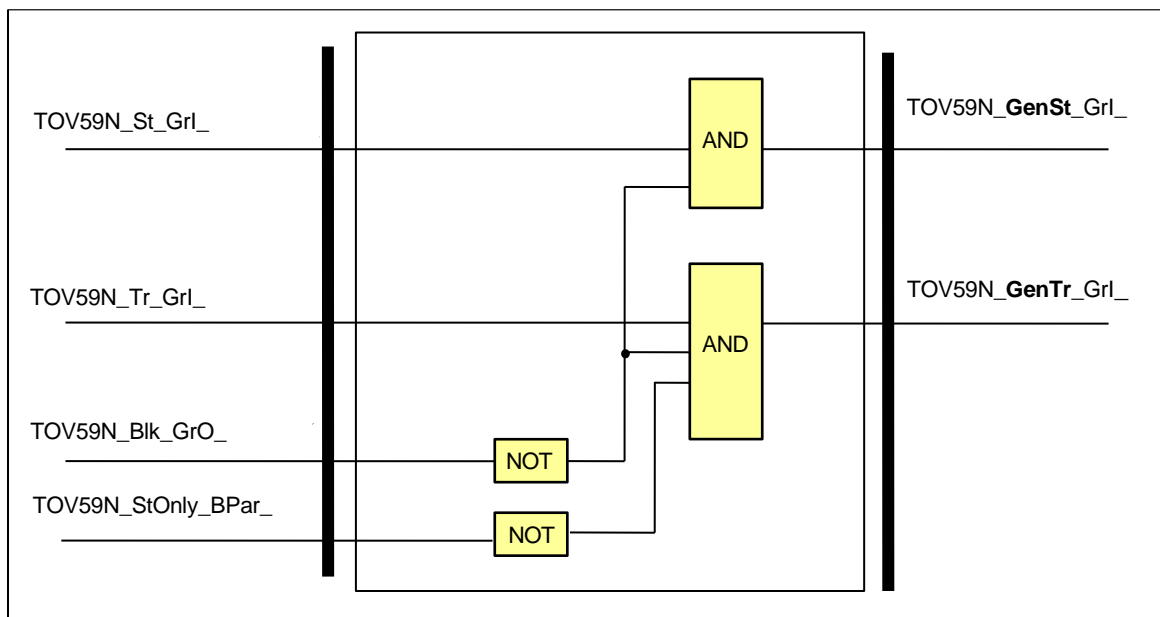

Figure 1-6 The logic scheme of the voltage based inter-turn fault protection function

Table 1-5 The binary input status signals of the decision logic scheme for the voltage based inter-turn fault protection function

BINARY INPUT SIGNALS	SIGNAL TITLE	EXPLANATION
TOV59N_St_Grl_	Start	Starting of the function
TOV59N_Tr_Grl_	Trip	Trip command of the function

Boolean parameter

Table 1-6 The Boolean parameter of the voltage based inter-turn fault protection function

PARAMETER NAME	TITLE	DEFAULT
Enabling start signal only:		
TOV59N_StOnly_BPar_	Start Signal Only	FALSE

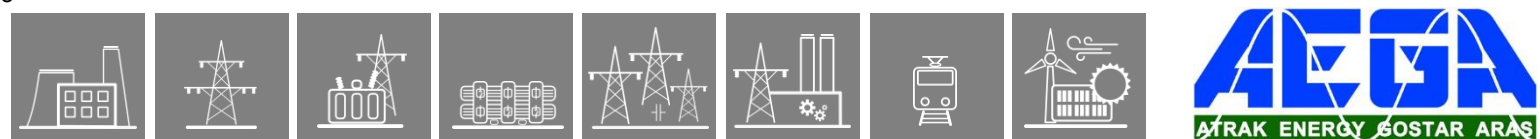

Binary status signals

The overvoltage protection function has a binary input signal, which serves the purpose of disabling the function. **The conditions of disabling are defined by the user, applying the graphic equation editor.**

Table 1-7 The binary input signal of the voltage based inter-turn fault protection function

BINARY STATUS SIGNAL	EXPLANATION
TOV59N_Blk_GrO_	Output status of a graphic equation defined by the user to disable the voltage based inter-turn fault protection function.

Table 1-8 The binary output status signals of the voltage based inter-turn fault protection function

BINARY OUTPUT SIGNALS	SIGNAL TITLE	EXPLANATION
TOV59N_GenSt_GrI_	General Start	General starting of the function
TOV59N_GenTr_GrI_	General Trip	General trip command of the function

2.1.27.2. Inter-turn fault protection function overview

The graphic appearance of the function block of the inter-turn fault protection function is shown below. The block shows all binary input and output status signals which are applicable in the graphic equation editor.

Note that because the same function block is used as that of the residual overvoltage function, the binary I/O of both functions are the same.

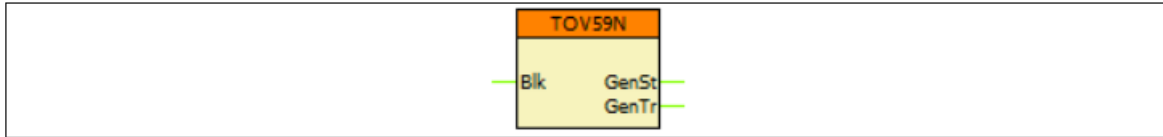

Figure 2-1 Graphic appearance of the function block of the inter-turn fault protection function

2.1.27.3. Settings

2.1.27.3.1. Parameters

The available parameters are listed below in order of their appearance in the *parameters* menu. If the setting range of a parameter should be extended, contact Protecta Support.

Table 2-1 Parameters of the inter-turn fault protection function

TITLE	DIM	RANGE	STEP	DEFAULT	EXPLANATION
Operation	-	Off, On	-	Off	Enabling the function
Start Signal Only	-	FALSE, TRUE	-	FALSE	Enabling start signal only
Start Voltage	%	2 – 60	1	30	Pickup setting value
Time Delay	msec	0 – 60000	1	200	Time delay (including the algorithm time, see Chapter 2.4 for more explanation)

2.1.27.4. Function I/O

This section describes briefly the analogue and digital inputs and outputs of the function block.

2.1.27.4.1. Analogue inputs

The function uses the sampled values of the 4th voltage input on the VT module.

2.1.27.4.2. Binary input signals (graphed output statuses)

The conditions of the binary inputs are defined by the user, applying the graphic equation editor (*Logic Editor*). Parts written in **bold** are seen on the left side function block in the Logic editor.

Table 2-2 The binary input signal of the inter-turn fault protection function

BINARY OUTPUT SIGNAL	EXPLANATION
TOV59N_ Blk _GrO_	Blocking input of the function

2.1.27.4.3. Binary output signals (graphed input statuses)

These signals can be used in EuroCAP to assign to LED, user LCD object etc. Parts written in **bold** are seen on the right side of the function block in the *Logic Editor*.

Table 2-3 The binary output signals of the inter-turn fault protection function

BINARY OUTPUT SIGNAL	SIGNAL TITLE	EXPLANATION
TOV59N_ GenSt _GrI_	General Start	General start signal of the function
TOV59N_ GenTr _GrI_	General Trip	General trip command of the function

2.1.27.4.4. Online data

Visible values on the *online data* page.

Table 2-4 Online displayed data of the inter-turn fault protection function

SIGNAL TITLE	DIMENSION	EXPLANATION
General Start	-	General start signal of the function
General Trip	-	General trip command of the function

2.1.27.4.5. Events

The following events are generated in the event list, as well as sent to the SCADA according to the configuration.

Table 2-5 Generated events of the inter-turn fault protection function

EVENT	VALUE	EXPLANATION
General Start	off, on	General start of the function
General Trip	off, on	General trip command of the function

2.1.28. Third harmonic differential overvoltage protection function description

2.1.28.1.1. Fundamental harmonic stator earth-fault protection

Partial stator earth-fault protection of generators is solved using TOV59N, 50 Hz zero sequence overvoltage function. This function is supplied by the neutral point voltage transformer or by the open delta connected voltage transformer at the connection side of the generator (See Figure 1–1).

The magnitude of the 50 Hz zero sequence voltage depends on the location of the stator earth-fault. As the earth-fault is getting closer to the neutral point, the 50 Hz zero sequence voltage decreases, and the protection function gets less and less sensitive. Accordingly, the setting value of the zero sequence voltage is advised to be set to a small value, to decrease the dead zone. The measured error voltages however act against this tendency: in case of earth faults at the connected high voltage network, a considerable zero sequence voltage is transmitted by the internal capacitances of the step-up transformer, and a third harmonic voltage distortion can also be detected. The fundamental harmonic component can be decreased using a resistor, connected to the open delta connected windings of the voltage transformers. The harmonic distortion can also be filtered using the Fourier method to get the fundamental harmonic component. With the application of these methods, about 85...90 % of the stator windings can be protected.

Due to the applied harmonic filter, which detects the 50 Hz fundamental harmonic, the voltage setting value may be below the measured voltage by a voltmeter, because in this voltage the 150 Hz component dominates.

The EuroProt+ system applies a zero sequence overvoltage protection function (TOV59N) to perform the fundamental harmonic earth-fault protection. This function is described in a separate document.

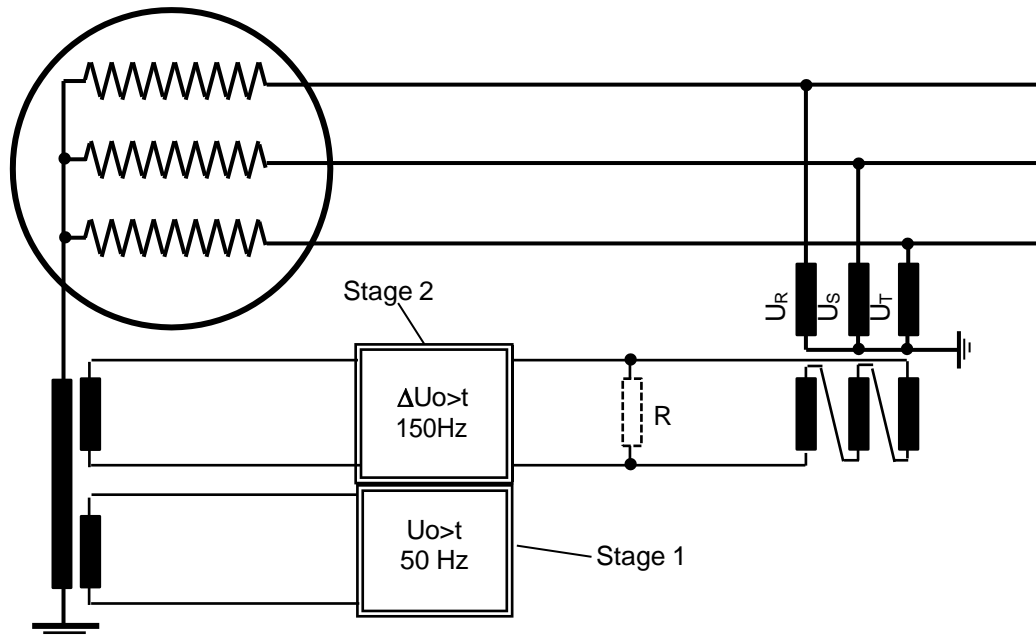

Figure 1–1 100% stator earth-fault protection for unit connected generators

2.1.28.2. Third harmonic earth-fault protection

The 100 % stator earth-fault protection of the generators is solved using the 150 Hz differential protection function (ΔU_{150}).

The U_{150} 150 Hz voltage component, generated in the stator coils of the generator has identical phasors in the phases (zero sequence), and due to the internal capacitances, it is distributed linearly in the coils symmetrical to the house (ground) (See Figure 1-2 a). Due to the additional capacitance of the transformer and that of the bus-bar, the voltage $U_t = U_{150_TERMINAL}$ will be smaller. In case of earth-fault in the star point, the capacitor at the star point side is shorted, accordingly the star point 150 Hz voltage gets zero, and that at the connection side increases (See Figure 1-2 b).

There are points inside the generator, where the 150 Hz voltage component is zero in case of normal operation (See Figure 1-2). Consequently in case of earth-fault at those points, the distribution of the third harmonic voltage component does not change. These points are approximately the midpoints of the stator coils. These points however can be protected using the 50 Hz overvoltage function, described in Paragraph 1.1. The joint application of both methods provides a 100 % earth-fault protection for the generator.

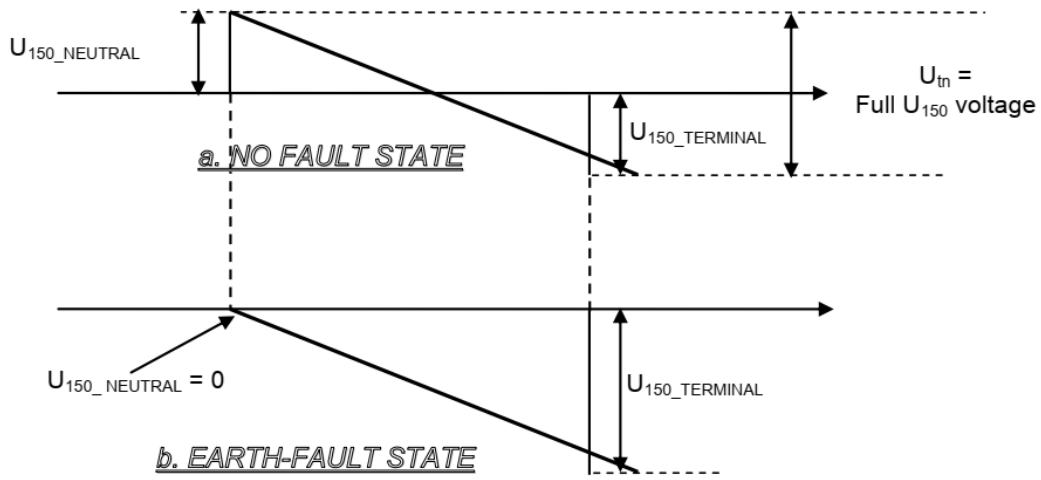

Figure 1-2 Distribution of the 150 Hz voltage component in the stator coils of the generator (generator operating alone, no resistance in the star point)

Depending on the load and excitation state of the generator, the full U_{150} voltage component changes in a broad range (1 ... 3, 1 ... 4). Accordingly, detecting the voltage component at the connection side only is not sufficient to detect an earth fault. The method to detect earth-faults near the star point is a special differential connection, which means comparing the full 150 Hz component ($U_{tn} = U_{150_TERMINAL} - U_{150_NEUTRAL}$) and that at the star point (See Figure 1-2, Stage 2). As the polarity of the full 150 Hz component and that at the star point is opposite, and also the magnitudes are different, for the comparison the protection algorithm first rotates the full voltage to the direction of the star point component, than it is decreased to match also the magnitude (See details below).

If the primary star point of the voltage transformers at the generator connection side is not connected to the ground, as it is shown in Figure 1-1, but to the star point of the generator, then the voltage transformers measure the full U_{tn} 150 Hz component. The applied connection is to be indicated by correct setting of parameter „Mode“. The setting „Un-Ut“ is to be selected if the star points of the voltage transformers at the connection side is grounded, the „Un-Utn“ mode however is to be selected if the primary star point of the voltage transformers is connected to the star point of the generator.

The turns ratio of the voltage transformers is set so that the star point voltage transformer and the open delta coils at the connection side indicate the same 50 Hz voltage in case of earth fault. Example: U_n line-to-line/ $\sqrt{3}$ /100/100 V, the open delta at the connection side: U_n line-to-line / $\sqrt{3}$ /100/3 V. In this case at earth fault at the connection side both voltages result 100 V to be detected in the protection device. If the turns ratios are different then the voltage inputs can be matched by two parameters („ U_n VT correction factor” and „ U_t/U_n VT correction factor”). Example in case of $U_{tn}=173V$, $U_n=240/\sqrt{3}=138V$ secondary voltages the values to be set are 1,73 and 1,38 respectively. Applying these correction factors, the resulting turns ratios between the primary environment and the voltage inputs of the algorithm are the same.

The protection based on the 150 Hz components compares the voltages at the star point and at the connection side, and checked if these voltage phasors are of opposite polarity and the magnitude differences in healthy state are balanced. This is valid if no resistance connected to the star point. Deviation related to the polarity is caused by a resistance connected in the star point, which distorts the capacitive voltage division. For this case the phasor diagram for the voltages is shown in Figure 1-3.

The balancing of the differential connection is shown in Figure 1-3. The full induced U_{tn} voltage is phase-shifted in the algorithm using a high-pass filter, to get a voltage of opposite polarity, related to the star point voltage. This phase-shifting corresponds to the frequency-dependent phase shifting of the internal capacitance of the generator and the star-point resistance. The result is the balanced state, independent of the frequency. The angle for phase shifting can be set in the range 0,05 ... 63 degrees, using the “Phase Shift” parameter values in the range of 0 ... 1024. (20 degrees correspond approximately to parameter value of 325). After the phase-shift compensation, the parameter „Multiplier” balances also the magnitude difference.

If no star point resistor is applied then the parameter for phase shift is to be set to 1. This results the minimum of the voltage error.

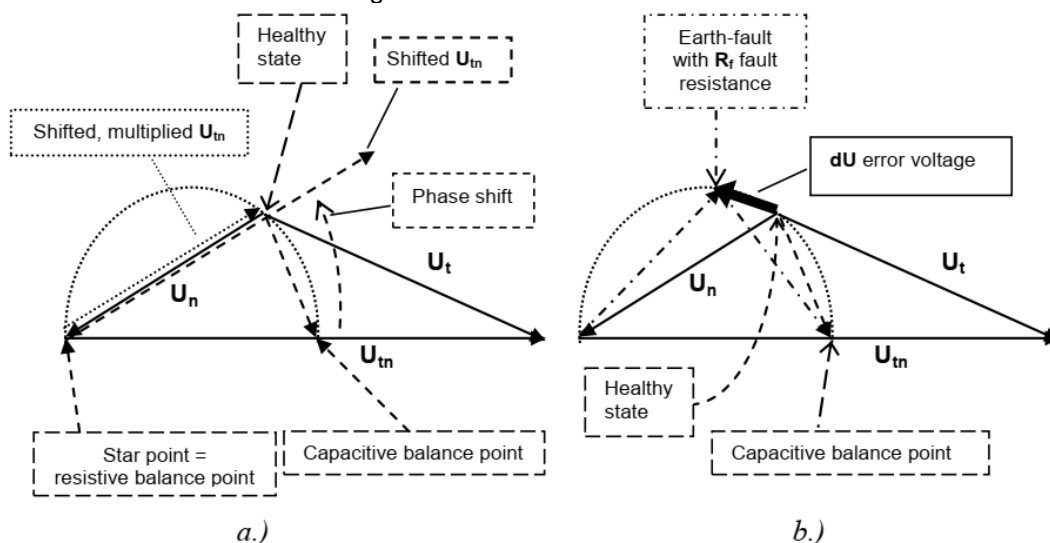
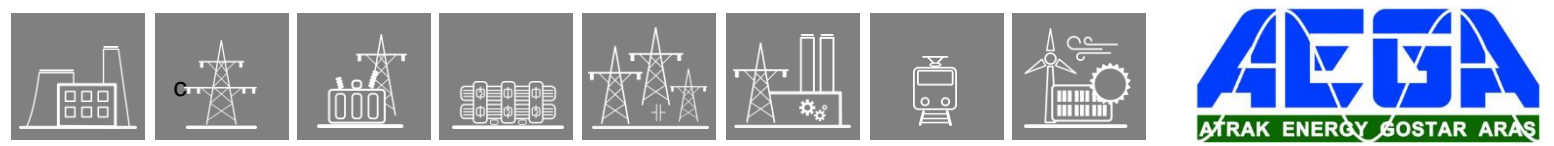

Figure 1-3 Phasor diagrams – Balancing, earth-fault

In case of earth fault with R_f fault resistance, the common point of the star-point voltage and the voltage at the connection point is shifted to the point indicated in Figure b) above. Accordingly the balance is broken (dU fault voltage), the protection function starts

- U_{tn}** the full 150 Hz voltage component, induced in the generator stator coils
- U_n** 150 Hz voltage at the star point
- U_t** 150 Hz voltage at the connection side



mode” parameter from “*Balancing*” to “*Normal*”. This setting resets the assignment of the buttons **I** and **O**, the balancing procedure is finished.

The same procedure is to be repeated for state B.

During the balancing procedure the trip command is disabled, the front panel buttons **I** and **O** are used to modify the phase shift.

For supplying the differential connection, two miniature circuit breakers with common operation should be installed in the secondary circuit of the star point voltage transformer and in the open delta of the connection side voltage transformers. With the common operation, both voltages disappear at the same time in case of any VT secondary circuit fault. If the common operation is not applied, then a fault in one of the VT secondary circuits causes unwanted trip command. If the common derive cannot be solved then the auxiliary contacts of the miniature circuit breakers, indicating open position, should be applied to block the protection function.

The 150 Hz earth-fault protection is installed with two stages. The first one is the warning stage; the second one can be applied to generate the trip command. Both of them have separate setting values and time delay.

The channel U1 of the voltage transformer input module of the device connects the voltage U_n/U_{tn} , the input U4 connects the star point voltage. To keep the highest possible sensitivity, the parameter setting for both channels is “*Phase*”. The role of the primary voltage value is only to display the voltages in primary scale. Accordingly this parameter cannot be set.

The displayed values are scaled to 1/10000 of the selected 100 V (or 200 V) rated values. The signals are recorded in the disturbance recorder in the same scaling. (1V 150 Hz is recorded as 100, when selecting RMS scaling). The setting values for the stages are interpreted with this scaling too. The on-line screen displays the values in %, the resolution is 0,001%.

The input voltages above 30V (for 220Vsetting above 60V) are limited. This means that above this value, the sampled values of the sinusoid are cut to the limit. This will generate an additional 150 Hz component, and this causes operation of the function even if the primary 150 Hz component is not sufficient for operation. This feature is needed in no load operation of the generator, when the induced 150Hz voltage component is low, and due to the installed capacitances at both sides of the machine level voltage transformers, the capacitive center point is shifted near to the connection point of the generator. In this state the voltage difference for earth-faults near to the connection point is low, and remains below the setting value. The voltage limitation is starting when the magnitude of the 50 Hz component reaches the 90% starting level of the 50 Hz first stage. This operation due to the voltage limitation is a backup protection function. The voltage limitation depends on the voltage. If the correction factors are set to different values then the voltage limitation starts at different values for earth-faults at a given location. If the “*Mode*” selection is set to “*Un-Utn*” then in case of earth-fault the U_{tn} does not contain 50 Hz component, the limitation is effective in U_n only.

2.1.28.3. Technical data

Function	Value	Accuracy
Drop-off ratio	0,9	
Characteristic accuracy		<2%
Time delay accuracy		±5% or ±15 ms, whichever is greater

Table 1-1 Technical data of the 100% earth-fault protection function

2.1.28.4. Parameters

2.1.28.4.1. Enumerated parameters

Parameter name	Title	Selection range	Default
TOV59TD_Oper_EPar_	Operation	Off, Un-Ut, Un-Utn	Off
TOV59TD_OpMode_EPar_	Mode of Operation	Normal, Balancing	Normal

Table 1-2 Enumerated parameters of the 100% earth-fault protection function

2.1.28.4.2. Integer parameters

Parameter name	Title	Unit	Min	Max	Step	Default
TOV59TD_PhShiftA_IPar_	Phase Shift State A		1	1024	1	512
TOV59TD_PhShiftB_IPar_	Phase Shift State B		1	1024	1	512
TOV59TD_WarnStVol_IPar_	Warning Start Voltage	%*0,01	10	500	1	100
TOV59TD_TrStVol_IPar_	Trip Start Voltage	%*0,01	10	500	1	100

Table 1-3 Integer parameters of the 100% earth-fault protection function

2.1.28.4.3. Float parameters

Parameter name	Title	Unit	Min	Max	Step	Default
TOV59TD_MultiA_FPar_	Multiplier State A		0,1	10.000	0,001	1
TOV59TD_MultiB_FPar_	Multiplier State B		0,1	10.000	0,001	1
TOV59TD_UNCorrFact_FPar_	Un VT Correction Factor		0,1	10.000	0,001	1
TOV59TD_UTCorrFact_FPar_	Ut/Utn VT Correction Factor		0,1	10.000	0,001	1

Table 1-4 Float parameters of the 100% earth-fault protection function

2.1.28.4.4. Timer parameters

Parameter name	Title	Unit	Min	Max	Step	Default
Definite time delay						
TOV59TD_WarnDelay_TPar_	Warning Delay	ms	0	60000	1	100
TOV59TD_TrDelay_TPar_	Trip Delay	ms	0	60000	1	100

Table 1-5 Timer parameters of the 100% earth-fault protection function

2.1.28.5. Binary status signals

2.1.28.5.1. Binary output status signals

Binary output status signal	Title	Explanation
TOV59TD_WarnSt_Grl	dU Warning Start	Start signal of the warning stage
TOV59TD_WarnTr_Grl	dU Warning Signal	Trip signal of the warning stage (Signal)
TOV59TD_TripSt_Grl	dU Trip Start	Start signal of the trip stage
TOV59TD_TripTr_Grl	dU Trip Command	Trip command
TOV59TD_StateB_Grl	State B	Active state is B
TOV59TD_Balancing_Grl	Balancing	Balancing mode

Table 1-6 Binary output status signals of the 100% earth-fault protection function

2.1.28.5.2. Binary Input status signals

Binary input status signal	Title	Explanation
TOV59TD_BlK_GrO_	Block	In case of active signal, the function is blocked
TOV59TD_StateB_GrO_	State B	In case of active signal, the function operates according to State B

Table 1-7 Binary input status signals of the 100% earth-fault protection function

2.1.28.6. Function block

The function block of the 100% earth-fault protection function is shown in Figure 1-5. This figure shows all input and output status signals, applicable in the graphic logic editor.

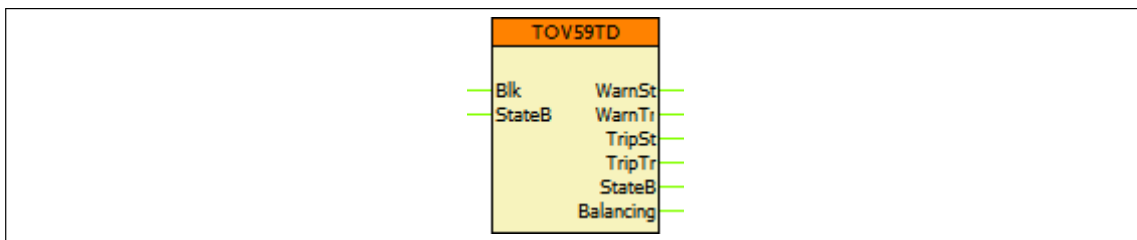

Figure 1-5 Function block of the 100% earth-fault protection function

2.1.28.7. Setting guide to the third harmonic differential overvoltage protection

2.1.28.7.1. Application examples

The third harmonic differential overvoltage protection function is designed to protect generator transformer units against ground faults near to the generator neutral point. (See Figure 7 and Figure 8) This function, applied jointly to the network frequency zero sequence overvoltage protection function, provides 100% stator earth fault protection.

The induced EMF in a synchronous generator contains harmonics. This method uses the third harmonic component to detect earth faults close to the neutral point and in the neutral point equipment. The third harmonic voltages have zero-sequence characteristic, accordingly, for the explanation of the operating modes, the zero sequence equivalent circuit of the generator transformer unit will be applied.

The practical arrangements of the generator transformer units can differ from each other in application of circuit breaker on the machine voltage level and in application of neutral grounding resistor. The Protecta TOV59_TD third harmonic differential overvoltage protection function can protect all these combinations.

The fault can be detected as a changed relation between the neutral point and generator terminal third harmonic voltages. In normal operation, the distribution of the third harmonic voltage in the system is defined by the distributed zero sequence capacitances and the neutral grounding resistor (if it is applied). The method supposes that the zero sequence capacitance of the system does not change (or it alternates between two values if the circuit breaker at machine voltage level is switched). Consequently this protection function cannot be applied to protect generators connected directly to the busbar, since the zero sequence capacitance changes in broad range, if the configuration changes due to connection and disconnection of other generators, lines, cables or transformers to the busbar.

2.1.28.7.1.1. Application in configurations without circuit breaker on the machine voltage level

2.1.28.7.1.1.1. Application without neutral grounding resistor

Figure 1 shows the equivalent zero sequence diagram of the configuration without machine voltage level circuit breaker and without neutral grounding resistor.

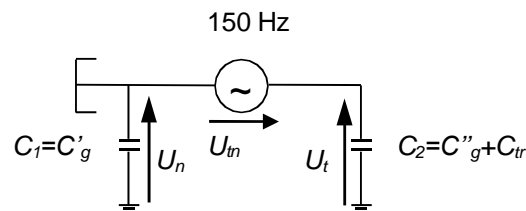

Figure 1 Zero sequence schema without neutral grounding resistor

- U_{tn} induced 150 Hz voltage component along the stator winding;
- U_n measured 150 Hz voltage component in the neutral point of the generator;
- U_t measured 150 Hz voltage component at the terminal point of the generator

With the positive directions of Figure 1:

$$U_t = U_n + U_{tn}$$

The voltage source represents the third harmonic induced voltage along the stator coils. The distributed capacitors are concentrated partly to the neutral point of the generator C_1 , partly to the generator terminal point C_2 . This C_2 capacitor includes also the zero sequence capacitor of the unit transformer. NOTE: the method does not need to know the value of the capacitors; the method is based on voltage measurements.

Figure 2 shows the vector diagram, using the positive directions of Figure 1.

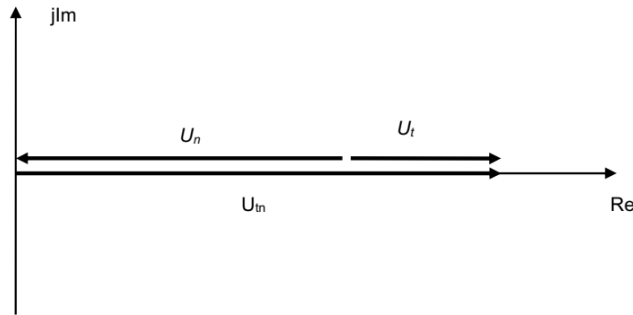

Figure 2 Third harmonic vector diagram without neutral grounding resistor

The method applies U_n , the 150 Hz voltage component measured in the neutral point and U_{tn} induced 150 Hz voltage component along the stator winding. The U_{tn} induced 150 Hz voltage component can either be directly measured, if the primary neutral point of the voltage transformers is connected to the neutral point of the generator (See Figure 7), or it can be calculated, if the primary neutral point of the voltage transformers is grounded (See Figure 8):

$$U_{tn} = U_t - U_n$$

The choice of the measurement is to be indicated by parameter setting “Operation= U_n-U_t ” if the primary neutral point of the voltage transformers is grounded (See Figure 8) and the terminal to ground voltage is measured or “Operation= U_n-U_{tn} ” if the primary neutral point of the voltage transformers is connected to the neutral point of the generator (See Figure 7) and the induced 150 Hz component is measured.

2.1.28.7.1.1.2. Application with neutral grounding resistor

Figure 3 shows the equivalent zero sequence diagram of the configuration without machine voltage level circuit breaker and with neutral grounding resistor.

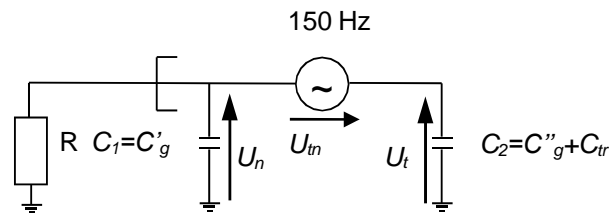

Figure 3 Zero sequence schema with neutral grounding resistor

Seen from the connection points of the resistor, an equivalent Thevenin generator can be derived See Figure 4.

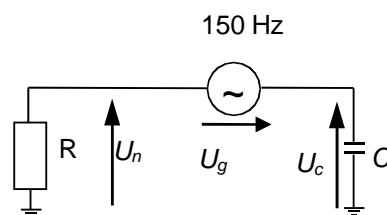

Figure 4 Zero sequence equivalent schema with neutral grounding resistor

where

$$C = C_1 + C_2$$

and

$$U_g = U_{tn} \frac{C_2}{C_1 + C_2}$$

U_n and U_c are resistive and capacitive voltages respectively. These voltages are perpendicular to each other. Consequently the vector diagram of Figure 5 can be drawn.

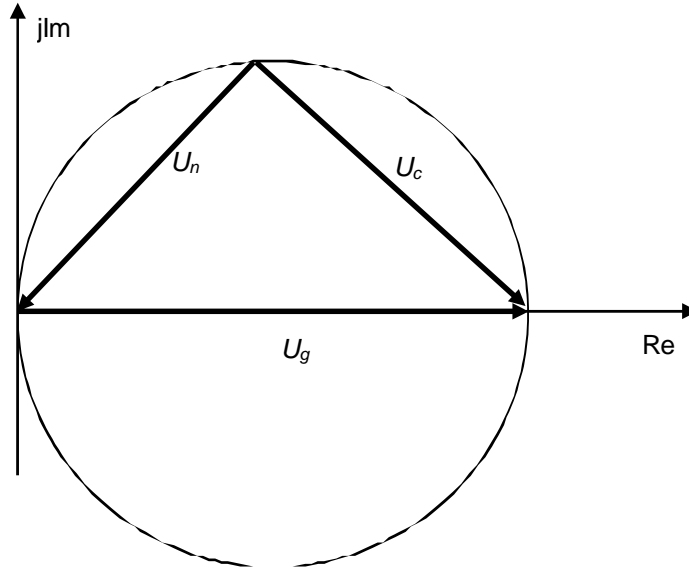

Figure 5 Vector diagram for the equivalent schema with neutral grounding resistor

Resolving the Thevenin equivalent of Figure 4 according to Figure 3, then the measurable voltages of Figure 6 can be drawn:

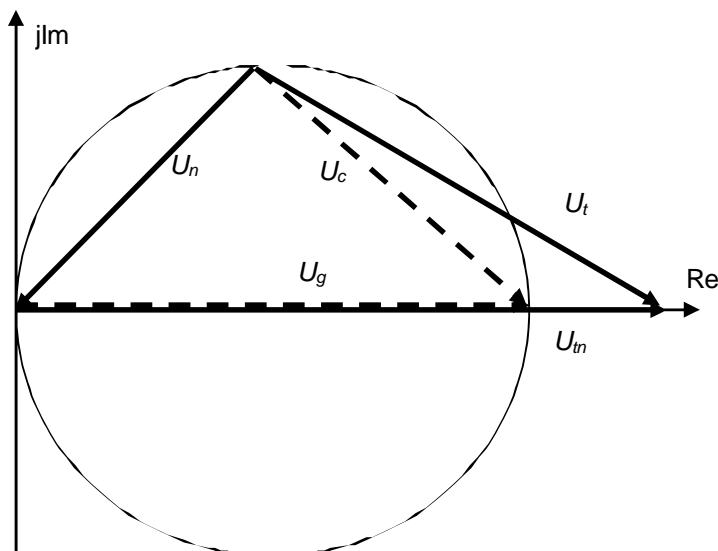
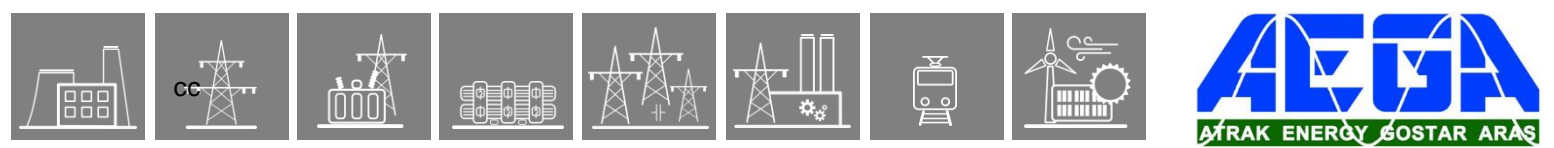

Figure 6 Vector diagram of the measured voltages with neutral grounding resistor



Comparing Figure 6 and Figure 5:

$$U_{tn} = U_g \frac{C_1 + C_2}{C_2}$$

and

$$U_t = U_n + U_{tn}$$

Based on the vector diagrams of Figure 2 (neutral grounding resistance is not applied) and Figure 6 (neutral grounding resistance is applied), the setting and the operation of the function can be explained below.

2.1.28.7.1.2. Application in configurations with circuit breaker on the machine voltage level

Switching off the circuit breaker at the machine voltage level disconnects the zero sequence capacitance of the unit transformer and that of the auxiliary transformer (if any). Accordingly there are basically two states of operation: “State A” when the circuit breaker is open and “State B” when the circuit breaker is closed.

The required balancing of the third harmonic voltage differential protection function is to be performed for both states. During operation of the generator, the auxiliary contact of the circuit breaker delivers information about the actual state.

Based on state of the circuit breaker, the protection function is adaptive; it considers the actual value of C_2 .

2.1.28.7.2. Connection diagrams

Figure 7 shows the application, where the VT primary star point connected to the generator star point. NOTE: for this connection a high voltage cable is needed between the star points, which can withstand the overvoltage during an earth fault!

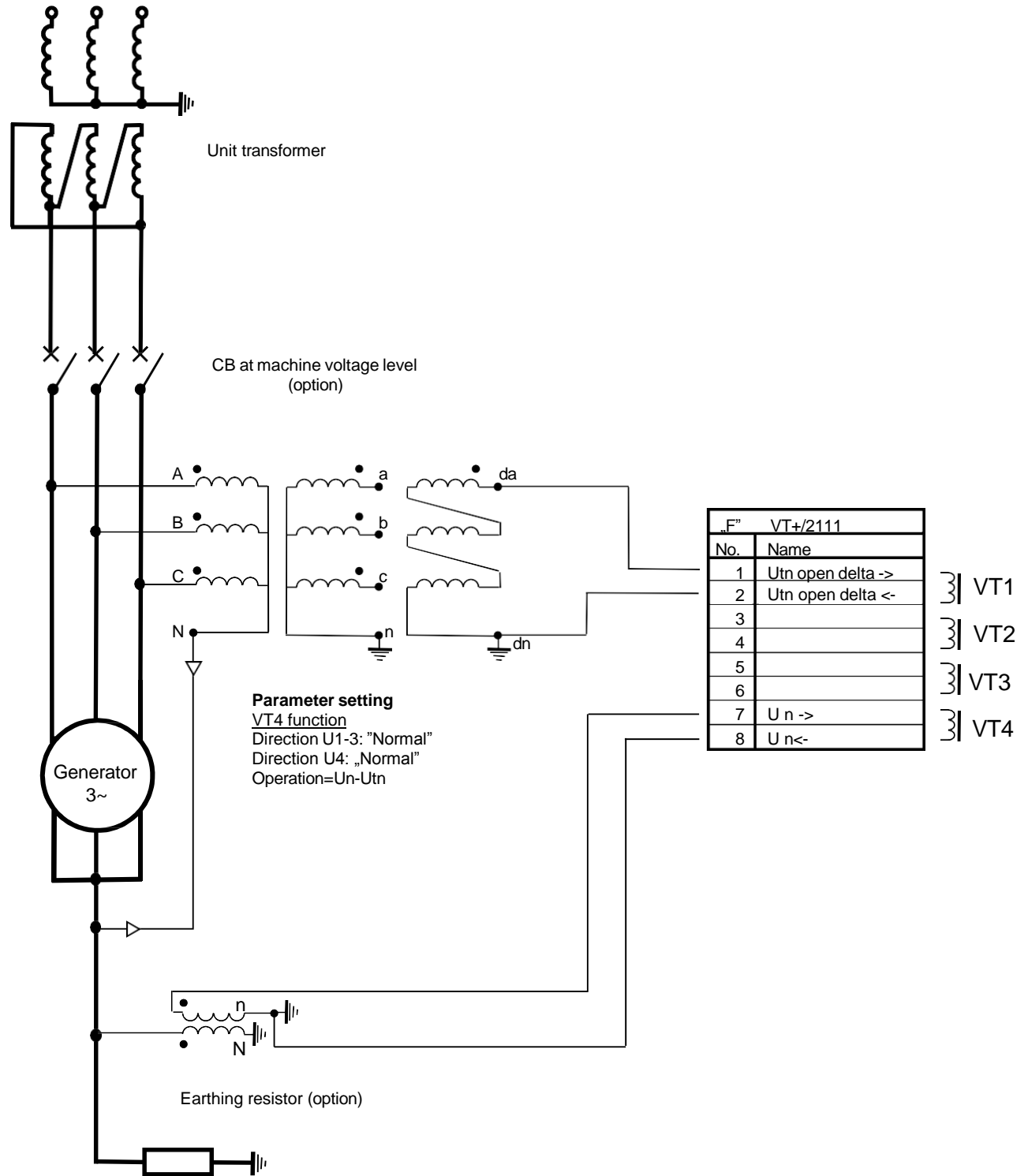

Figure 7 Connection diagram with VT star point connected to the generator star point

Figure 8 shows an application where the VT primary star point is grounded.

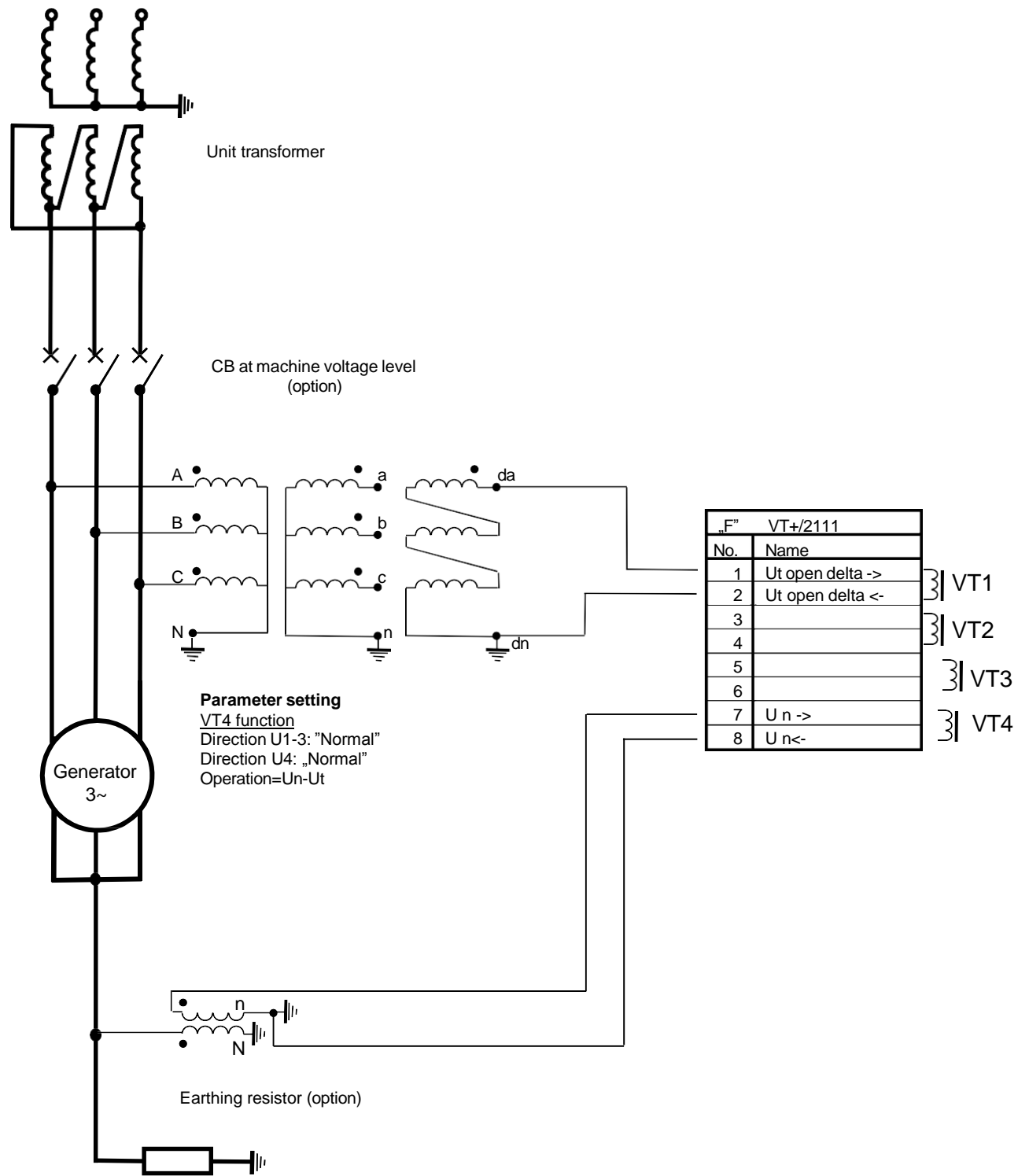

Figure 8 Connection diagram with VT star point grounded

Connect the voltage of the open delta and that at the neutral point according to Figure 7 or Figure 8. The corresponding parameter settings will be explained below.

2.1.28.7.3. Basic parameter setting

2.1.28.7.3.1. Setting the parameters of the voltage input module

The following parameters are valid if the voltage of the open delta and that at the neutral point are connected according to Figure 7 or Figure 8. The corresponding parameter settings are explained in Table 3-1.

Parameter	Selection	Explanation
Range	Type 100	The type indicates the rated secondary voltage of the VT. This can be 100 V (in this example) or 200V. The displayed values in % are referring to this voltage.
Connection U1-3	-	This parameter is hidden, no setting is required
Connection U4	-	This parameter is hidden, no setting is required
Direction U1-3	Normal	Figure 7 or Figure 8 shows the normal VT connection, i.e. the signed \square phase wire is connected to the terminal 1. (Select "Inverted" in case of inverted connection.)
Direction U4	Normal	Figure 7 or Figure 8 shows the normal VT connection, i.e. the signed \square phase wire is connected to the terminal 7. (Select "Inverted" in case of inverted connection.)
VT correction	-	This parameter is hidden, no setting is required
Rated Primary U1-3	15.75	Setting, according to the VT rated voltage, applied at the primary side. This parameter is used for scaling the displayed values only.
Rated Primary U4	15.75	Setting, according to the VT rated voltage, applied at the primary side. This parameter is used for scaling the displayed values only.

Table 3-1 Example parameters for the voltage input function

These basic settings are displayed in the parameter window of the VT4 module

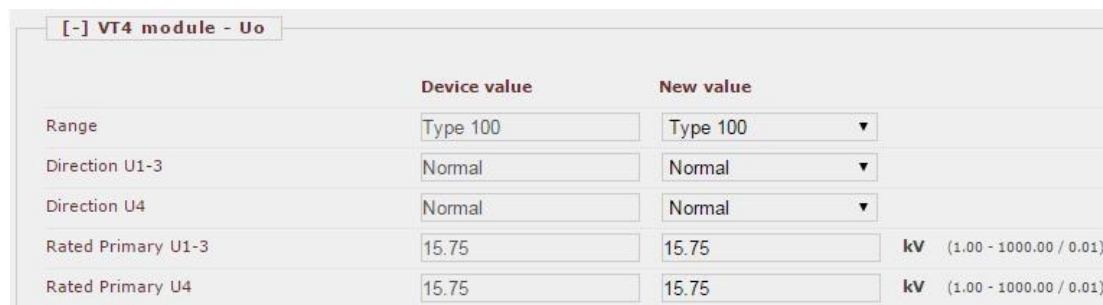

	Device value	New value	
Range	Type 100	Type 100	
Direction U1-3	Normal	Normal	
Direction U4	Normal	Normal	
Rated Primary U1-3	15.75	15.75	kV (1.00 - 1000.00 / 0.01)
Rated Primary U4	15.75	15.75	kV (1.00 - 1000.00 / 0.01)

Figure 9 Parameters of the VT4 voltage input module

2.1.28.7.3.2. Parameter of the VT star point connection

The VT star point connection at the terminals of the generator determines if U_t or U_{tn} voltage is measured directly. This parameter basically influences the correct operation of the protection function. If the arrangement is according to Figure 7 (the VT star point is connected to the generator star point) then set the parameter „Operation= Un-U_{tn}“. If the arrangement is according to Figure 8 (the VT star point is grounded) then set the parameter „Operation= Un-U_t“.

Parameter	Selection	Explanation
Operation	Off Un-U _{tn} Un-U _t	“Off” disables the operation of the function Select the setting according to the explanation above.

Table 3-2 Selecting the mode of operation

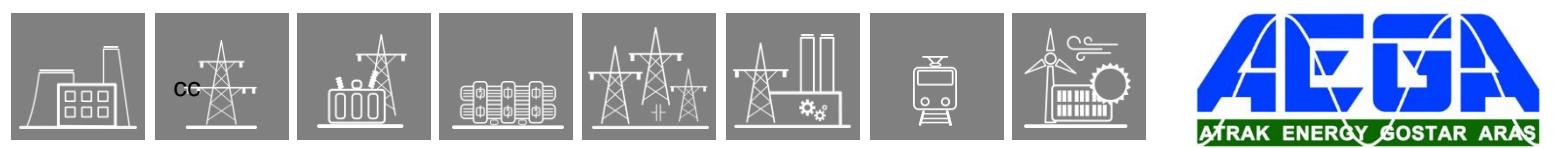

2.1.28.7.4. Balancing the third harmonic voltage differential protection

2.1.28.7.4.1. Balancing mode

The induced 150 Hz voltage continuously changes with the load state of the generator. Based on experiences however, the ratio of the neutral voltage 150 Hz component and the terminal residual voltage measured in open delta VT-s: U_n/U_t is practically unchanged. (The relatively slight deviation is covered by parameter settings: “Warning Start Voltage” and “Trip Start Voltage”.)

Actually the algorithm uses U_n (the neutral voltage 150 Hz component) and the U_{tn} (the induced voltage 150 Hz component) for comparison. For the continuous calculation, these voltages must be matched to each other. This is the “balancing” procedure.

To enter “balancing mode” set parameter “Mode of Operation = Balancing”. After finishing the procedure, do not forget to reset this parameter “Mode of Operation = Normal”.

In “Balancing mode” the protection function does not generate the trip command. Additionally, the two pushbuttons in the front panel of the device (I) and (O) serve step-by-step parameter setting and supervising the effect of parameter modification. The balancing procedure is described in this chapter.

2.1.28.7.4.2. Balancing without neutral grounding resistor

If no neutral grounding resistor is applied then the vector diagram is shown again in Figure 10.

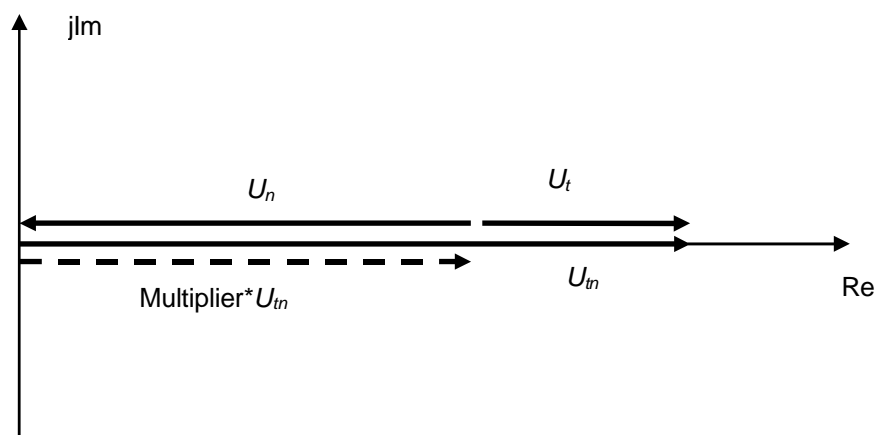

Figure 10 Third harmonic vector diagram without neutral grounding resistor

The dotted vector “Multiplier* U_{tn} ” shows the required balanced state:

$$dU_{bal} = U_n + Multiplier * U_{tn} = 0$$

If it is possible, perform the following steps at about half of the rated load $0.5P_n$ and $0.5Q_n$. (Experiences show that in other load states it will result the optimal measuring errors.)

	Device value	New value	
Operation	Un-Ut	Un-Ut	
Mode of Operation	Balancing	Balancing	
Un VT Correction Factor	1	1	(0.100 - 10.000 / 0.001)
Ut/Ut _n VT Correction Factor	1.000	1.000	(0.100 - 10.000 / 0.001)
Phase Shift State A	1	1	(1 - 1024 / 1)
Multiplier State A	1.000	0.598	(0.100 - 10.000 / 0.001)
Phase Shift State B	1	1	(1 - 1024 / 1)
Multiplier State B	1.000	1.000	(0.100 - 10.000 / 0.001)
Warning Start Voltage	20	20	%*0.01 (10 - 500 / 1)
Warning Delay	100	100	msec (0 - 60000 / 1)
Trip Start Voltage	50	50	%*0.01 (10 - 500 / 1)
Trip Delay	100	100	msec (0 - 60000 / 1)

Figure 12 Parameter window before balancing (No neutral grounding resistor)

- Check the On-line window again:

[-] Stator Earthfault		
dU State A	0.000	%
dU _{bal} State A	0.000	%
Multiplier State A	0.598	
Angle State A	179	deg
Phase Shift State A	1	
dU State B	0.202	%
dU _{bal} State B	0.000	%
Multiplier State B	0.598	
Angle State B	179	deg
Phase Shift State B	1	
State B	<input type="checkbox"/>	
dU Warning Start	<input type="checkbox"/>	
dU Warning Trip	<input type="checkbox"/>	
dU Trip Start	<input type="checkbox"/>	
dU Trip Command	<input type="checkbox"/>	
Balancing	<input checked="" type="checkbox"/>	

Figure 13 On-line window after balancing (No neutral grounding resistor)

The measured dU=0.000, the balancing is correct.

NOTE: After setting and checking all parameters, do not forget to reset: "Mode of Operation = Normal"

The local display of the device also supports the procedure of balancing. Figure 14 shows the device on-line window before balancing and Figure 15 does after balancing.



Figure 14 On-line window before balancing (No neutral grounding resistor)



Figure 15 On-line window after balancing (No neutral grounding resistor)

Figure 15 shows the measured values after successful balancing. Here the $dU=0.000$.

2.1.28.7.4.3. Balancing with neutral grounding resistor

If neutral grounding resistor is applied then the vector diagram is shown again in Figure 16.

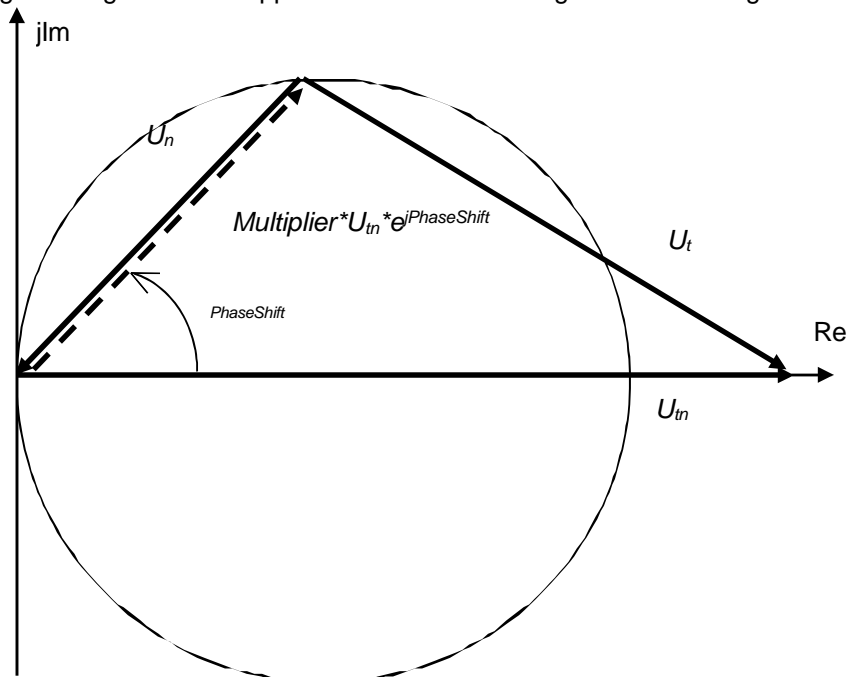

Figure 16 Third harmonic vector diagram with neutral grounding resistor

The dotted vector “Multiplier* $U_{tn} * e^{iPhaseShift}$ ” shows the required balanced state:

$$dU_{bal} = U_n + Multiplier * U_{tn} * e^{iPhaseShift} = 0$$

If it is possible, perform the following steps at about half of the rated load $0.5P_n$ and $0.5Q_n$. (Experiences show that in other load states it will result the optimal measuring errors.)

- Set in the parameter window “Mode of Operation = Balancing”
- Open the On-line window of the “Stator Earthfault” protection function (See Figure 17).

[-] Stator Earthfault		
dU State A	0.624	%
dUbal State A	0.347	%
Multiplier State A	0.343	
Angle State A	-159	deg
Phase Shift State A	1	
dU State B	0.624	%
dUbal State B	0.347	%
Multiplier State B	0.343	
Angle State B	-159	deg
Phase Shift State B	1	
State B	<input type="checkbox"/>	
dU Warning Start	<input checked="" type="checkbox"/>	
dU Warning Trip	<input type="checkbox"/>	
dU Trip Start	<input checked="" type="checkbox"/>	
dU Trip Command	<input type="checkbox"/>	
Balancing	<input checked="" type="checkbox"/>	

Figure 17 On-line window before balancing (With neutral grounding resistor)

Check:

- “Balancing” is checked. It means that the operating mode is balancing; no trip command will be generated.
- In unbalanced state, the measured dU is not zero.
- Because the angle is not set correctly, dUbal is not zero either.
- Balancing the angle is performed as follows:
Increase (or decrease) „Phase Shift” using the two push-buttons in the front panel of the device (I) and (O). Observe “dUbal” value on the on-line screen. In case of correct direction of changing the angle, this value should decrease. NOTE: the steps are relatively small to achieve the required accuracy. The push-button (X) on the front panel is used in “balancing state” to toggle between 1x step and 10x step. Additionally the procedure ends quicker if the starting angle as set by parameter “Phase Shift” is more realistic (Try it with the default 512, as a starting value.)

Figure 18 shows the state just before the correct phase shift value. Observe “Angle=180 deg”. Figure 19 shows the state just after the correct phase shift value. Observe “Angle=-179 deg”. The dUbal calculated value in both cases is 0.000.

2.1.28.7.4.4. Balancing with machine level circuit breaker

The circuit breaker on the machine voltage level disconnects the capacitance of the unit transformer and that of the auxiliary transformer (if any). Consequently there are two states to be operated with: State A when the circuit breaker is open (no load state) and State B when the circuit breaker is closed.

The balancing procedure described in 4.2 for the configuration without neutral grounding resistor or the procedure described in 4.3 for the configuration with neutral grounding resistor shall be repeated for both states.

For this configuration, which serves the case of circuit breaker on the machine voltage level, there are two parameters to be set for phase shift matching:

“Phase Shift State A” and “Phase Shift State B” and similarly two parameters to be set for magnitude matching: “Multiplier State A” and “Multiplier State B”.

The function block in the EuroCap configuration tool has a dedicated binary input: “StateB”. This input selects one set of parameters only. The displayed values refer also to the actual state only.

If there is an active signal on this binary input then State B is active. This input is to be programmed for the application when a circuit breaker on the machine voltage level is applied. The signal can be e.g. a status signal received from the auxiliary contact of the circuit breaker.

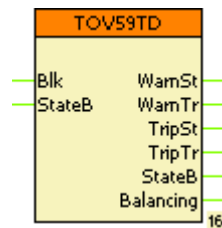
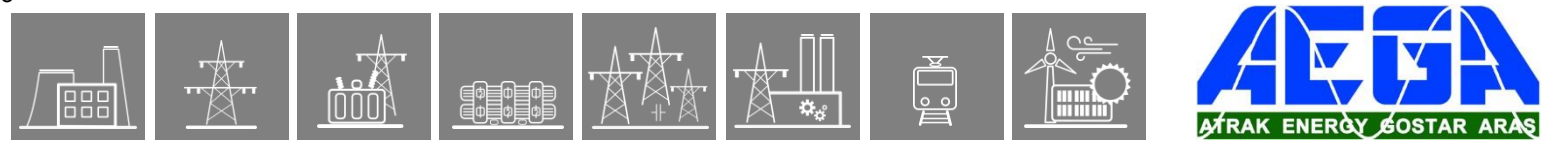

Figure 22 Function block of the third harmonic differential overvoltage protection



2.1.28.7.4.5. Setting the threshold values and the timers

The third harmonic differential overvoltage protection function supervises the dU value, calculated as:

$$dU = U_n + Multiplier * U_{tn} * e^{iPhaseShift}$$

In balanced state without earth-fault, this value is near zero, if it is not then it is caused either by measuring error or by earth-fault. The threshold values “Warning Start Voltage” and “Trip Start Voltage” serve this separation for the warning stage and for the trip stage respectively. The required setting values are advised to be measured during operation of the generator. For this, all possible operating conditions and load states should be considered.

The on-line screen continuously monitors dU. Find the maximum value during normal states: dUMax. The advised setting is:

Warning Start Voltage > 1.5 * dUMax Trip Start Voltage > 2 * dUMax

To keep sensitivity for high resistive faults, do not set too high values.

The time delays should over-bridge the transient periods e.g. for detection of the circuit breaker operation times. Set these parameters accordingly:

“Warning Delay” “Trip Delay”

NOTE: After setting and checking all parameters, do not forget to reset: “Mode of Operation = Normal”.

2.1.28.7.4.6. Checking the operation of the protection function

A usual method to check the operation of the third harmonic differential overvoltage protection is as follows:

The method supposes a correctly balanced parameter setting as it is described above.

In not excited state of the generator, connect an (additional) grounding resistor to the neutral of the generator, simulating an earth-fault. Slowly increase excitation, and check the 50 Hz voltage at the generator terminals. If the protection function operates (a warning signal or a trip command is generated) read the voltage value. This voltage related to the rated voltage is the sensitivity of the protection function. When performing the measurement in not loaded state, the result will be the sensitivity in most critical state.

When increasing the value of the (additional) grounding resistor, the sensitivity of the function for high impedance earth-fault can also be evaluated.

NOTE:

The algorithm includes a limitation of the sampled values of the zero sequence voltages at about 30% of the rated phase voltage. This limitation artificially generates third harmonic component, which changes the balance of the measurement. With this extension of the algorithm, the third harmonic differential overvoltage protection function can provide by itself a 100% stator earth-fault protection for the generator.

2.1.29. Rotor Earth Fault protection for isolated rotors

This rotor earth fault protection function (RotEF) can be applied to provide protection against rotor earth faults in generators, where the excitation circuit is isolated from the rotor iron core. The method applies cyclic DC voltage and zero voltage (earthing) toggling for the measurement. Due to the measuring arrangement, the accuracy of the measured fault resistance is independent of the exciting voltage and of the fault location (which part of the exciter voltage is inside the measuring loop) as well.

If both poles of the excitation winding are available, then additionally to the fault resistance, also the fault location relative to the positive brush and the exciting voltage can be calculated. The calculated exciting voltage can be applied to a rotor overload protection function in the form of overvoltage detection: $U_e > t$.

If only one of the poles of the excitation winding is available (e.g. in the case of excitation with rotating diodes) then the fault location and the exciting voltage cannot be calculated. The accuracy of the fault resistance calculation is however independent of these two factors.

The applied algorithm is selected by parameter setting.

2.1.29.1. Operation principle

The protection applies 100 V auxiliary DC voltage via resistance network between the rotor and the earth; then this point is connected to the earth (0 V is connected). The connected voltage is measured, and the total injected current and also the current flowing to the positive pole is measured. After decaying the transients in the network consisting of the resistance of the coupling network, the earth capacitances of the excitation circuit and those of the filter circuits of the coupling network, these measured values are recorded. The six registered values are applied to calculate the fault resistance (R_f), the fault location relative to the positive pole (k) and the exciting voltage (U_e).

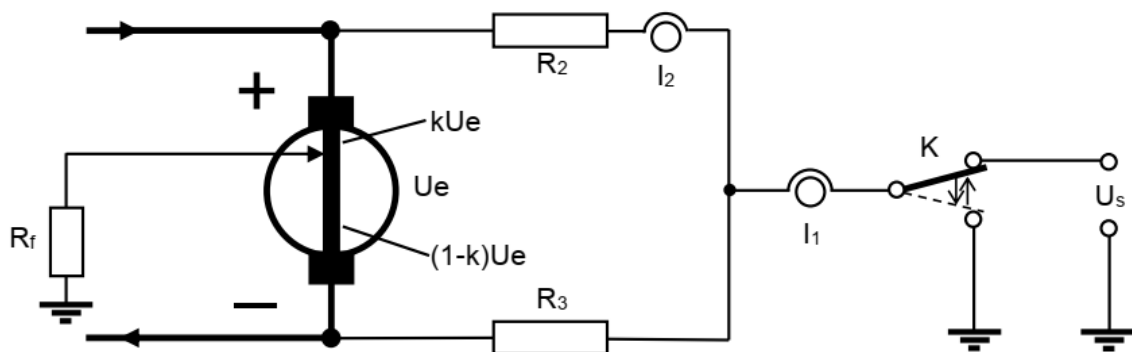

Figure 1-1 Connecting to the generator

'K' in Figure 1-1 above is a switch that is realized by an electrical circuit. The part connected to the ground has also voltage limiting function, to avoid overvoltage in the auxiliary voltage, caused by the connected part of the excitation voltage, resulting a current flowing in reverse direction.

If only one pole of the excitation voltage is available for connection, then the left side of the resistances R_2 and R_3 (see Figure 1-1) are pulled together to create a common point. This common point is connected to the rotor circuit.

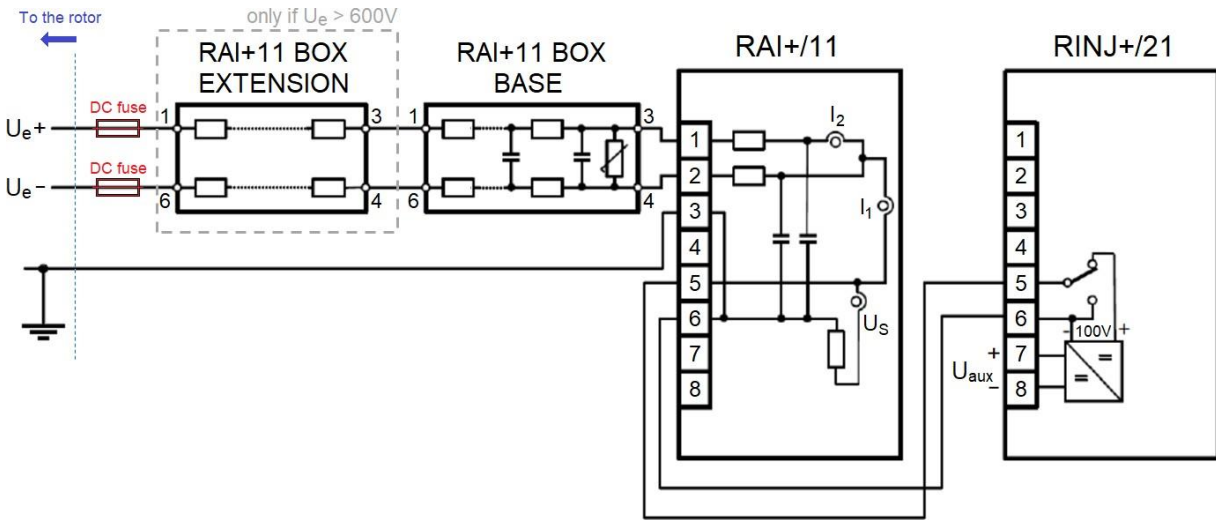

Figure 1-2 Wiring for ConnType1 mode (connecting to two points)

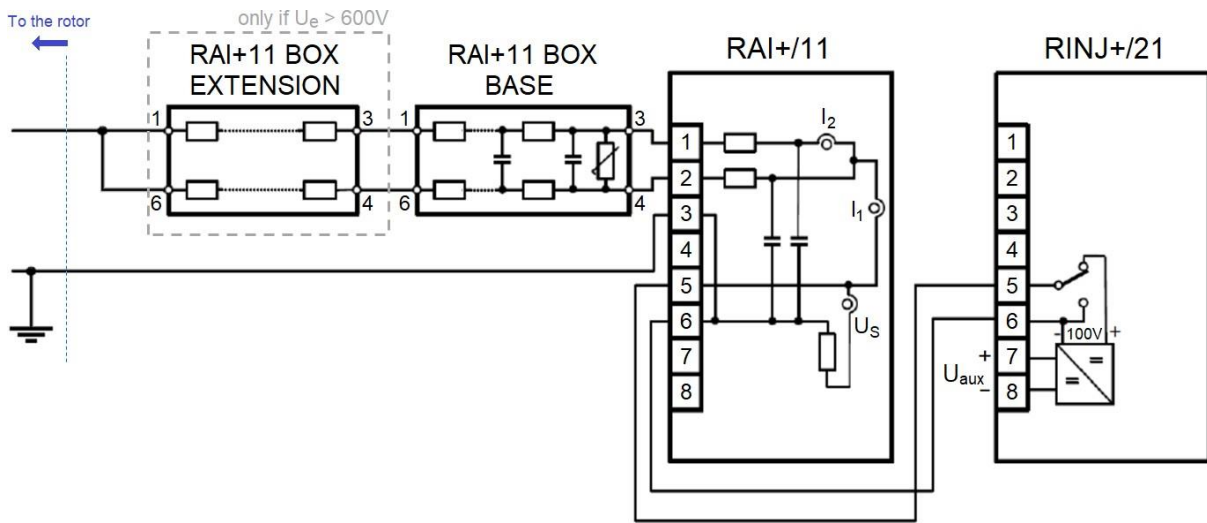

Figure 1-3 Wiring for ConnType2 (single point connection) mode

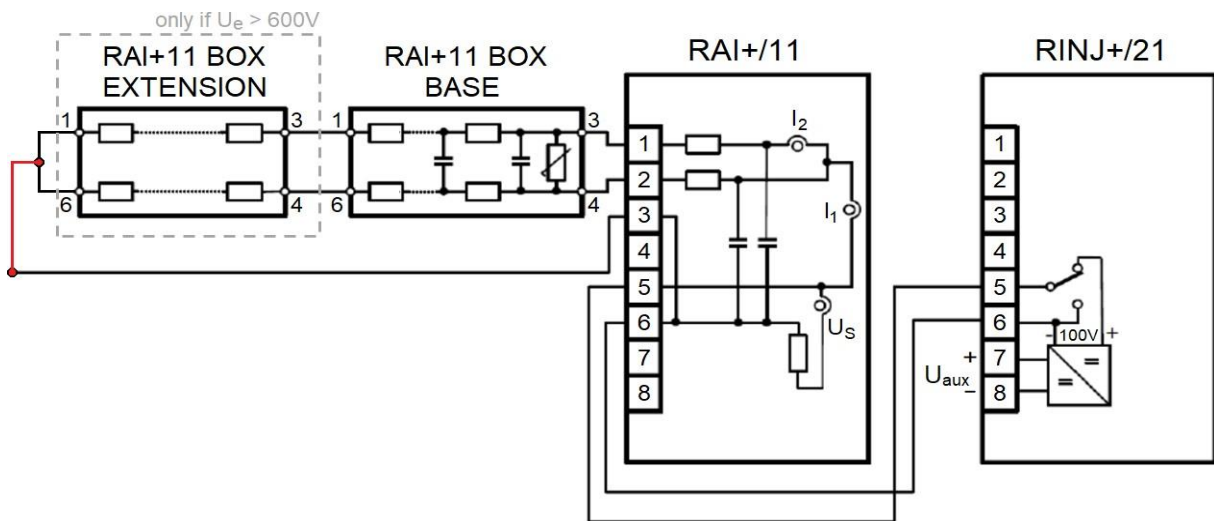

Figure 1-4 Wiring for Calibration mode

2.1.29.1.3. The properties of the measuring principle

The measuring method results in the value of the loop resistance. This is the sum of the fault resistance and the coupling resistance, which is the parallel equivalent of the coupling resistances at both sides. The fault resistance is calculated as the difference of these elements. As an example: if the fault resistance is 1 k Ω then with application of one coupling element (BASE only) then the measured loop resistance is 21 k Ω ; with the application of both coupling modules, it is 36 k Ω . The subtraction of appropriate values results in 1 k Ω . It can be seen that even in the case of accurate measurement the relative error is larger than the usual one if it is related to the expected 1 k Ω . *If it is possible, use only one coupling element to decrease the relative error.*



As it is explained above, the exact value of the equivalent coupling resistance is needed for the calculation (one part of it is located in the coupling unit, the other one is in the RAI+/11 hardware module). The exact value can be measured using the function itself, by connecting the interconnected point of the positive and negative cables to the ground. (This is the external connection point 3 of the module RAI+/11). At the same time, the mode of operation of the function is to be set to calibration mode. The on-line window of the function block displays the resistance value R2 normally connected to the positive pole and the resistance value R3, normally connected to the negative pole. It is advised to perform this calibration procedure during normal operation (at normal operation temperature) of the protection IED to reach the offset of the LEM modules the steady-state value. Usually, the measured values show some fluctuation. Try to estimate the average values to be set as parameters for R2 and R3.



When static excitation system is used then due to the controlled bridge connection, the excitation voltage shows steep edges with the frequency of three times of the network frequency.

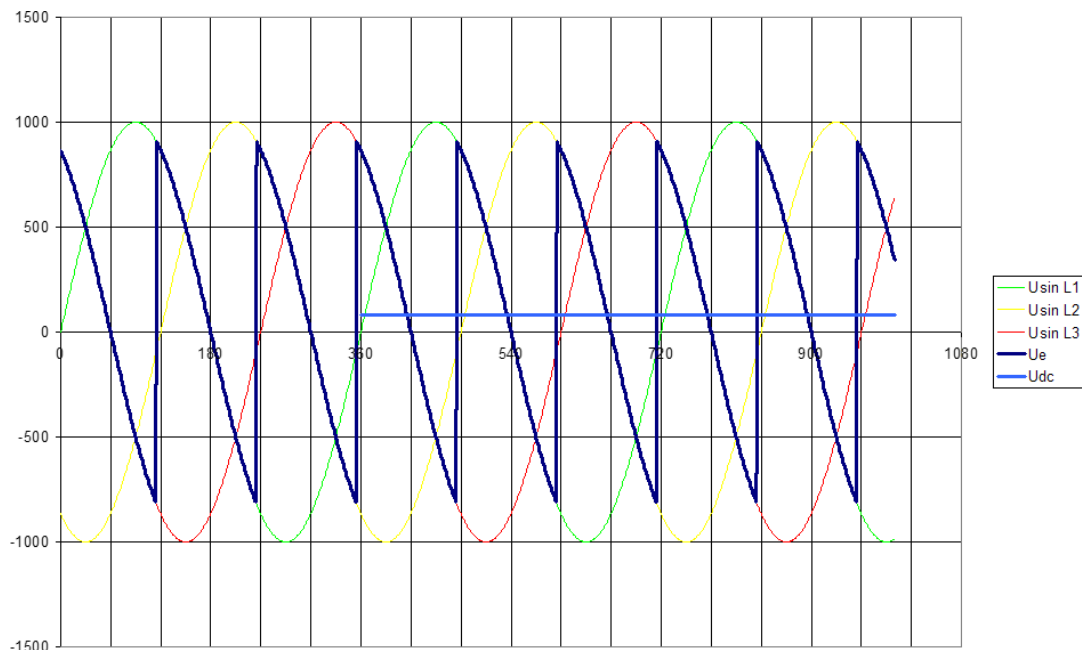

Figure 1-5 Excitation voltage components (phase voltages from the excitation transformer, the excitation voltage itself and its average value)

The average value of this time function is the actual excitation voltage. The excitation current is damped by the inductance of the rotor circuit. The largest jump in the voltage can be measured if the average excitation voltage is zero. If the ignition is delayed less than needed for zero average then the excitation voltage is increased, and it can even be inverted by delaying the ignition. For quick demagnetization, this property can be exploited.

It is obvious that for example at 1000 V rated value the injected voltage 100 V for measuring purposes has a relatively high noise voltage. To filter out this noise, the capacitors located in the auxiliary box BASE and also in hardware unit RAI+/11 serve as a filter circuit. Additionally, the algorithm of the function block realizes a digital filter function.

As it was described above, the measurement is performed by periodically changed 100 V measuring voltage and 0 voltage. To filter out external noises of network frequency, the toggling moment of time between the measuring voltage and the grounding can be set as an integer factor of the network time period. With this choice, the storing of the measured values is performed always at the same time, relative to the network sinusoidal voltage. Using this method, the steady-state periodic noises can be eliminated.

For the evaluation, the values U_s , I_1 , I_2 stored at the end of the half period with 100 V measuring voltage and those at the end of the grounded state are needed. At starting of the device and at parameter setting, the stored values are deleted. In these cases, a full measuring period is needed for evaluation. In normal operation, the evaluation is performed in every half period. Based on the calculated values, for the operation of the function and also for reset, three subsequent evaluation with the same result are needed. This means that after the level violation, two additional measuring half periods are needed for operation, and also for reset. This also means that the operating state lasts at least two measuring half periods. The **time delay** for operation is advised to be set for the value **at least three times of the half measuring period** to bridge over a possible random short-time operation. This rule of thumb is also valid for the $U_{e>}$ stage. To increase the speed of operation, a short half-period time selection is advised, however, this has a lower limit value to bridge over the toggling transients.



The time for the half measuring period is to be selected to leave time for the transients to decay. This is related to the time constant of the circuit, related to the mentioned RC filters and RC circuits consisting of the coupling resistances and earth capacitances of the rotor. If the waiting time is shorter than it is required, then the measured value is less than the expected one. This can be checked using a test resistor. The waiting time must be a compromise between speed and accuracy, considering the required shorter operation time – mostly it is advised to set it in a way in order that the accuracy is good enough at the lower Ohm setting of the two stages' start settings.

If there are changes in the primary circuit, e.g. the reserve excitation system is applied with longer connecting cable of larger capacitance, then the test is advised to be repeated.

2.1.29.1.4. Example for operation

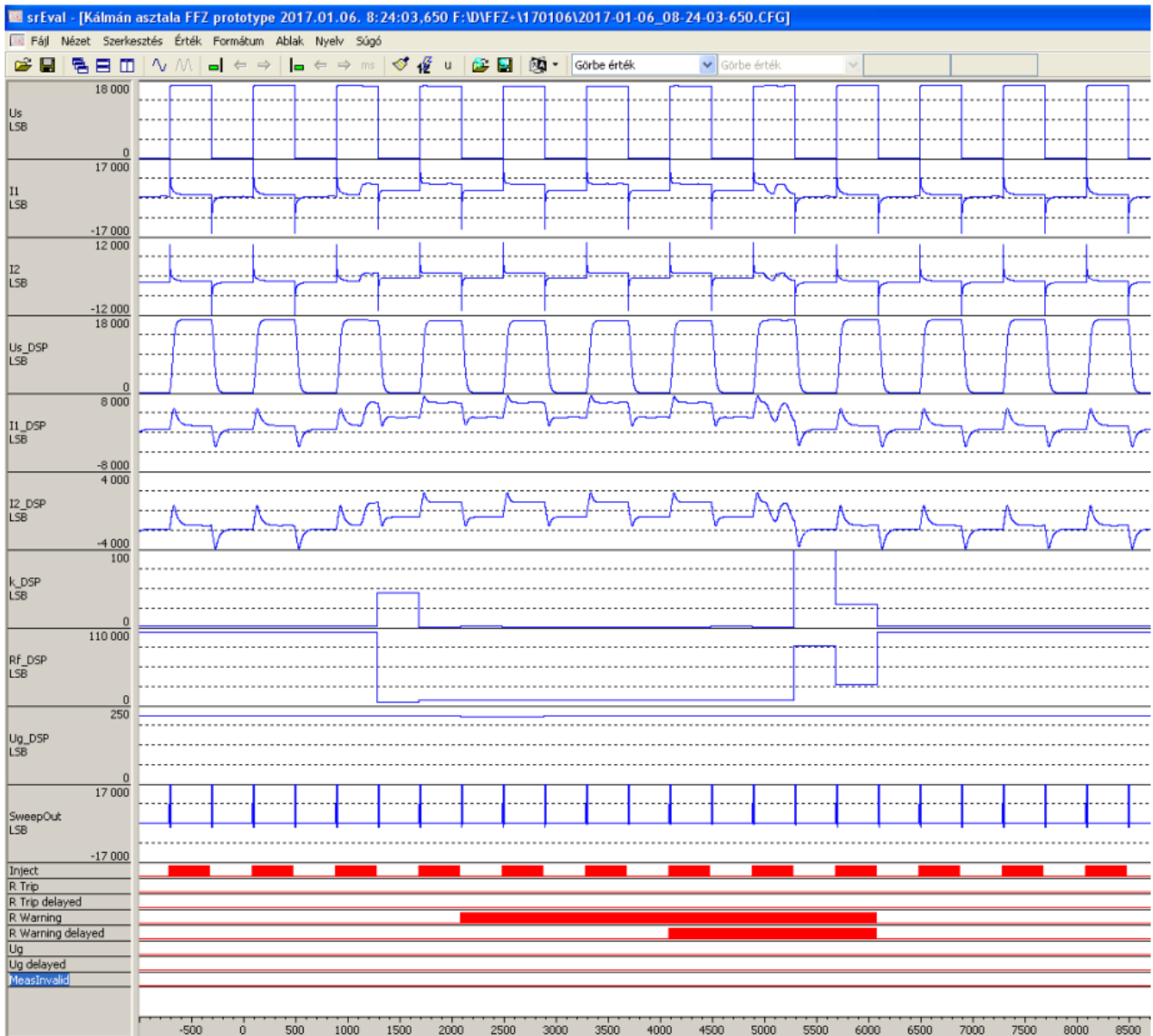

Figure 1-6 Disturbance record of an operation

The first three channels (Us, I1, I2) record the signals measured directly by the A/D converter. The subsequent three channels (Us-DSP, I1-DSP, I2-DSP) show these signals after numerical filtering, but in internal scaling. The members of the third group of the signals (k-DSP, Rf-DSP, Ug-DSP) are calculated values in natural scaling. The last analog signal “SweepOut” serves future evaluation. The diagram was recorded by manual triggering to record also long time pre-fault state. The “SweepOut” signal involves the recorded Us, I1, I2 values at the moment of the last three Us changes (three full measuring periods). Using this signal, the last three measured values can be evaluated later.

The recorded signals show that the fault is detected is at the third measuring half period after fault inception. This is valid also for reset state.

2.1.29.2. Rotor earth fault protection function overview

The graphic appearance of the function block of the rotor earth fault protection function is shown below. The block shows all binary input and output status signals which are applicable in the graphic equation editor.

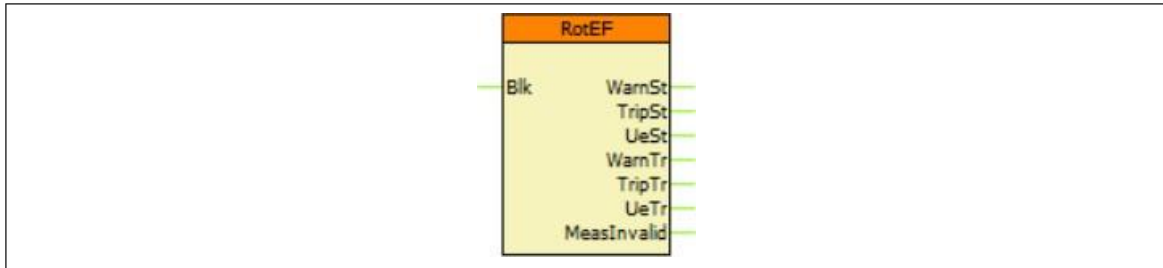

Figure 2-1 Graphic appearance of the function block of the rotor earth fault function

2.1.29.3. Settings

2.1.29.3.1. Parameters

The available parameters are listed below in order of their appearance in the *parameters* menu. If the setting range of a parameter should be extended, contact Protecta Support.

Table 2-1 Parameters of the rotor earth fault function

TITLE	DIM	RANGE	STEP	DEFAULT	EXPLANATION
Operation	-	Off, ConnType1, ConnType2, Calibration	-	Off	Off: function switched off ConnType1: both connection points available ConnType2: only single connection point available Calibration: special mode for measuring the coupling resistances
Halfperiod length	powercycle	1 – 1000	1	50	Setting value for the measuring half period
R2	ohm	35000 – 80000	1	40000	Exact value of the coupling resistor at the <i>positive</i> pole
R3	ohm	35000 – 80000	1	40000	Exact value of the coupling resistor at the <i>negative</i> pole
Warning Start	ohm	4000 – 40000	1	10000	Setting resistance value of the warning stage
Warning Delay	msec	1000 – 64000	1	2000	Time delay for the warning stage
Trip Stage Start	ohm	4000 – 40000	1	10000	Setting resistance value of the trip stage
Trip Stage Delay	msec	1000 – 64000	1	2000	Time delay for the trip stage
Ue Start	V	50 – 1500	1	200	Setting voltage value for the Ue>t (excitation overvoltage) stage
Ue Delay	msec	1000 – 64000	1	2000	Time delay for the Ue>t (excitation overvoltage) stage

2.1.29.4. Function I/O

This section describes briefly the analogue and digital inputs and outputs of the function block.

2.1.29.4.1. Analogue inputs

The function uses the following analogue signals as inputs:

- Sampled values of the auxiliary voltage to be switched on the circuit
- Sampled values total injected current
- Sampled values current on the positive pole

2.1.29.4.2. Analogue outputs (measurements)

The measured values of the differential protection function are listed in the table below.

Table 2-2 The measured analogue values of the rotor earth fault function

MEASURED VALUE	DIMENSION	EXPLANATION
R2 meas.	ohm	Measured R2 resistance during calibration
R3 meas.	ohm	Measured R3 resistance during calibration
Rf	ohm	Measured fault resistance
k	%	Fault location, relative to the positive brush. (It can be measured only if both poles of the excitation circuit are available, <i>ConnType1</i>) If the value is not realistic then the displayed value is 999.
Ue	V	Measured excitation voltage. (It can be measured only if both poles of the excitation circuit are available, <i>ConnType1</i>)

2.1.29.4.3. Binary input signals (graphed output statuses)

The conditions of the binary inputs are defined by the user, applying the graphic equation editor (*Logic Editor*). Parts written in **bold** are seen on the left side function block in the *Logic Editor*.

Table 2-3 The binary input signals of the rotor earth fault function

BINARY OUTPUT SIGNAL	EXPLANATION
RotEF_BIk_GrO_	Blocking input of the function

2.1.29.4.4. Binary output signals (graphed input statuses)

These signals can be used in EuroCAP to assign to LED, user LCD object etc. Parts written in **bold** are seen on the right side of the function block in the *Logic Editor*.

Table 2-4 The binary output signals of the rotor earth fault function

BINARY OUTPUT SIGNAL	SIGNAL TITLE	EXPLANATION
RotEF_WarnSt_Grl_	Warning Stage Start	This signal indicates starting of the warning stage
RotEF_TripSt_Grl_	Trip Stage Start	This signal indicates starting of the trip stage
RotEF_UeSt_Grl_	Ue Start	This signal indicates starting of the Ue> stage
RotEF_WarnTr_Grl_	Warning Stage Delay	This signal indicates timeout of the warning stage
RotEF_TripTr_Grl_	Trip Stage Delay	This signal indicates timeout of the trip stage
RotEF_UeTr_Grl_	Ue Trip	This signal indicates timeout of the Ue> stage
RotEF_MeasInvalid_Grl_	Invalid Measurement	This signal indicates invalid measurement, if in connected state, $U_s < 50V$ or in grounded state $U_s > 50V$.



2.1.29.4.5. Online data

Visible values on the on-line data page:

Table 2-5 Online displayed data of the rotor earth fault function

SIGNAL TITLE	DIMENSION	EXPLANATION
R2 meas.	ohm	Measured R2 resistance as the result of calibration
R3 meas.	ohm	Measured R2 resistance as the result of calibration
Invalid Measurement		This signal indicates invalid measurement, if in connected state, $U_s < 50V$ or in grounded state $U_s > 50V$.
Rf	ohm	Measured fault resistance
k	%	Fault location, relative to the positive brush. (It can be measured only if both poles of the excitation circuit are available, ConnType1) If the value is not realistic then the displayed value is 999.
Ue	V	Measured excitation voltage. (It can be measured only if both poles of the excitation circuit are available, ConnType1)
Warning Stage Start	-	This signal indicates starting of the warning stage
Trip Stage Start	-	This signal indicates starting of the trip stage
Ue Start	-	This signal indicates starting of the $U_e >$ stage
Warning Stage Delay	-	This signal indicates timeout of the warning stage
Trip Stage Delay	-	This signal indicates timeout of the trip stage
Ue Trip	-	This signal indicates timeout of the $U_e >$ stage

2.1.29.4.6. Events

The following events are generated in the event list, as well as sent to SCADA according to the configuration.

Table 2-6 Generated events of the rotor earth fault function

EVENT	VALUE	EXPLANATION
Warning Stage Start	off, on	Starting of the warning stage
Trip Stage Start	off, on	Starting of the trip stage
Ue Start	off, on	Starting of the $U_e >$ stage
Warning Stage Delay	off, on	Timeout of the warning stage
Trip Stage Delay	off, on	Timeout of the trip stage
Ue Trip	off, on	Timeout of the $U_e >$ stage

2.1.29.5. Technical data

Table 2-7 Technical data of the rotor earth fault function

FUNCTION	VALUE	ACCURACY
Resistance range	0 – 1000000 Ω	$\pm 10\% \pm (R2+R3)/400 \Omega$
Setting resistance range	4000 – 40000 Ω	$\pm 5\% \pm (R2+R3)/400 \Omega$
k (fault location relative to the positive brush)	0 – 100 %	$\pm 5\%$
Excitation voltage	0 – 1300 V	$\pm 5\%$
Setting excitation voltage range	50 – 1300 V	$\pm 5\%$
Operating time	(2-3) * half measuring period	$\pm 10 \text{ ms}$
Reset time	(2-3) * half measuring period	$\pm 10 \text{ ms}$
Reset ratio for R<	1,1 * setting + 1000 Ω	
Reset ratio for Ue>	0,9	
Timer (started at fault detection)		$\pm 5 \text{ ms}$

2.1.29.6. Commissioning and testing

Connections are made according to Figure 2-2, see below. The other figures of this section are based on this figure, and only those parts are shown that are different. The mentioned BOX refers to the one that connects to the generator itself (BASE, if it is the only BOX in use, and EXTENSION, if both are installed).

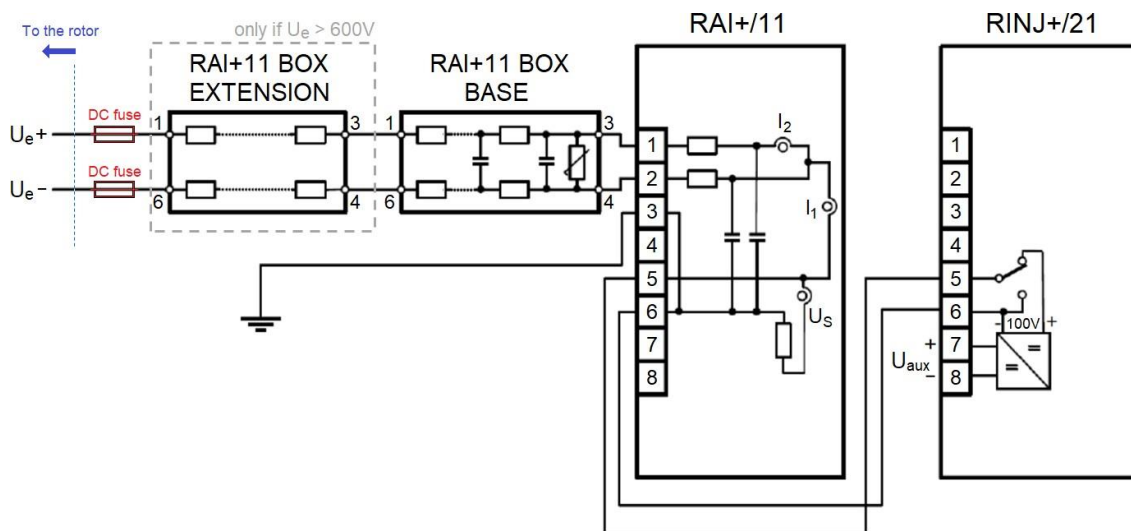

Figure 2-2 Wiring of internal (RINJ and RAI) and external (BOX) modules



The injector and measuring units **are to be connected to the excitation circuit via fuses**. The applied fuse should be prepared for the special purpose: it should be capable of interrupting the high excitation DC current. A representative value at $U_n = 1000 \text{ V}$ is $I_n = 2000 \text{ A}$.



The selection of the connection point must assure that the protection gets the excitation voltage in both cases: when the excitation voltage is switched over from the normal operation voltage to the reserve excitation source. In other words, the device must be connected to the rotor at all times via fuses, regardless which exciter is working on the rotor.

2.1.29.6.1. Calibration of the R2 and R3 coupling resistances

The resistances of the coupling circuit (R2 and R3) are about 40 k Ω on both sides (or 70 k Ω if the extension box is utilized as well), but for accurate measurement, their actual values must be measured and entered before putting the function into operation.

The calibration process is the following:

- a) Connect the inputs #1 and #6 together of the BOX (BASE or EXTENSION, according to the actual setup) to the earth point of the RAI+/11 module (pin #3), see the left side of the picture below:

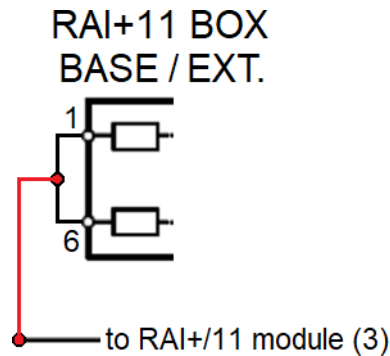

Figure 2-3 Connection for calibration

- b) Set the Operation parameter of the function to “Calibration”
- c) Check the on-line measurements of the function, and write down the values of “R2 meas.” and “R3 meas.”
- d) Enter these values to the parameters “R2” and “R3”, respectively
- e) Exit the calibration mode by choosing another “Operation” parameter setting

Once these parameters are set, and the operation is other than “Calibration”, the “R2 meas.” and “R3 meas.” on-line values are not important anymore.

2.1.29.6.2. Testing

Testing the function requires at least one external DC voltage source. With that, the essential parts of the function, namely the Warning and Trip stages, and the $U_{e>}$ (excitation overvoltage) can be commissioned and tested.

Testing the fault locator (on-line measured as “k”) requires an additional DC source, otherwise it will show either 0% or 100% during testing, see below.

This chapter describes both modes of testing the function.

2.1.29.6.2.1. Testing the essential parts (Warning, Trip, $U_{e>}$)

The excitation voltage is simulated by an external DC source, see the blue part (U) on the picture below. If the only DC supply is the auxiliary voltage that is used on the RINJ+/21 module (mentioned as U_{aux} in Figure 2-2), it can be utilized for this as well.

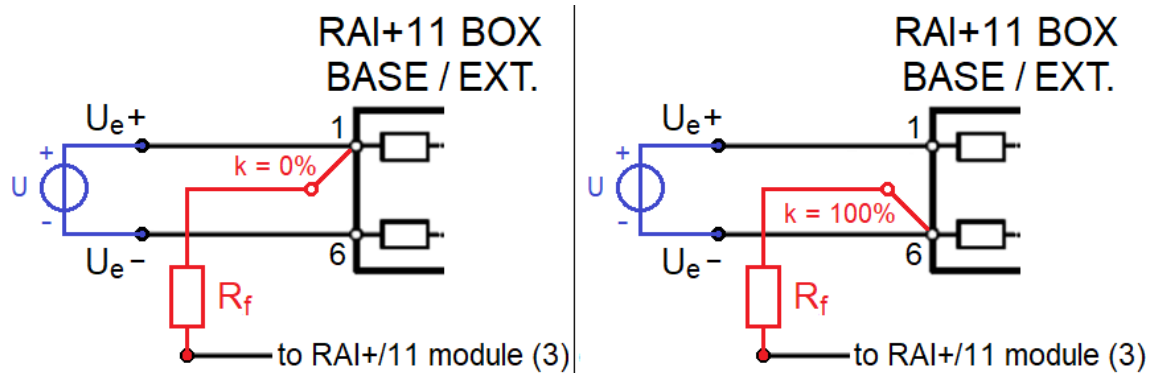

Figure 2-4 Connection for testing with one DC source with R_f at either end of the rotor

The red part (R_f) is a settable resistor, whose one pole is connected to the RAI+/11 module’s 3rd pin (the “earth”), and the other pole is connected to one input of the BOX (#1 or #6 – see the left or right part of Figure 2-4). The value of the R_f resistor represents the fault resistance. This is what the functions’ stages are based on.

For testing the function, do the following:

- Check the operation parameter (the function must not be disabled or in calibration mode)
- Set the resistor **above** the parameter setting; this serves as a pre-fault state
- Change the resistance **below** the parameter setting; the function will operate.
- The $U_{e>}$ stage can be tested similarly by adjusting the U voltage of the supply

Note that for proper test results, the length of the measuring halfperiod and the time delay of each stage must be set properly as well, otherwise two issues might come up:

- the function operates at lower R_f than expected, if the halfperiod length is set too low
- the function operates with way lower delay than expected, if the delay is set to less than at least three times of the half measuring period (at least this time is required to obtain a proper measurement)

For setting up these two parameters properly, see Chapter 2.4.3.

2.1.29.6.2.2. Testing the fault locator

In the previous chapter, by connecting the R_f resistor either to input #1 or #6 of the BOX, an earth fault is simulated with R_f fault resistance either on the positive or negative brush of the rotor. This is the reason why the value of the measured “k” is either 0% or 100% during such testing.

If a fault between these points is to be simulated, then two series-connected DC sources (U_1 and U_2 on the figure below) are required for the simulation of the the excitation voltage.

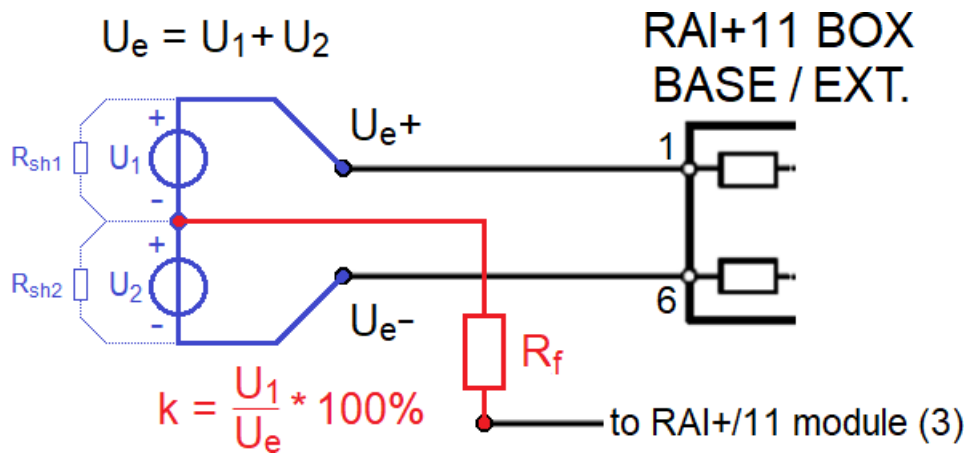

Figure 2-5 Connection for testing with two DC sources

The sum of these two voltages is the measured excitation voltage. Their ratio determines the “location” of the fault. With an example of an excitation voltage of **200V**:

Table 2-8 Simulation of different fault locations

U1 VOLTAGE	U2 VOLTAGE	RELATIVE LOCATION “K”
0 V*	200 V	0%
20 V*	180 V	10%
60 V	140 V	30%
100 V	100 V	50%
150 V	50 V	75%
200 V	0 V*	100%

*Low voltage setting results in bigger current flowing back into the DC power supply, which may not be supported by it. In this case, an additional resistor (R_{sh} on the figure above) is to be installed between the + and – outputs of each supply as a shunt for protecting it.



The resistor must be chosen in a way that least **20 mA** flows on it at the minimum testing voltage (20 mA is the maximum DC current that can be injected by the protection device). Keep in mind that this resistor must endure all test voltages!



When testing at the limits at the rotor (i.e. 0% or 100%, where either U_1 or U_2 voltage is zero), the protection of the power supply is not possible with the shunt resistor. Because of this, tests at these points must be performed with **one DC source only (see the previous chapter)**!

2.1.29.6.2.3. Testing with single-point connection (ConnType2) (Warning & Trip only)

Since there is no excitation voltage measurement here, a settable resistor (R_f) is enough to test the functionality. The resistor's one pole is connected to the RAI+/11 module's 3rd pin (the "earth"), and the other pole is connected to the already connected inputs of the BOX (#1 and #6 – see the left or right part of Figure 2-6).

The value of the R_f resistor represents the fault resistance. This is what the functions' stages are based on.

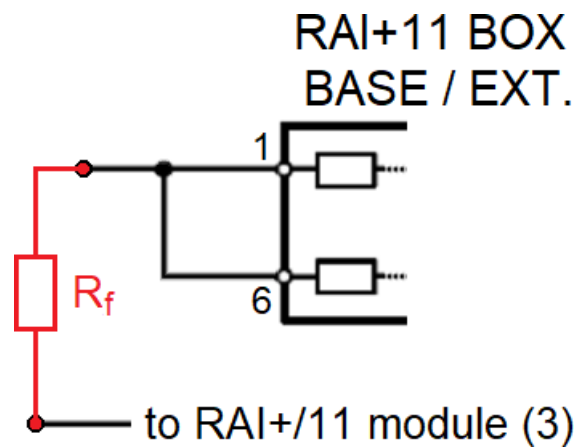

Figure 2-6 Connection for testing on one connection point

For testing the function, do the following:

- Check the operation parameter (the function must not be disabled or in calibration mode)
- Set the resistor **above** the parameter setting; this serves as a prefault state
- Change the resistance **below** the parameter setting; the function will operate.

Note that for proper test results, the length of the measuring halfperiod and the time delay of each stage must be set properly as well, otherwise two issues might come up:

- the function operates at lower R_f than expected, if the halfperiod length is set too low
- the function operates with way lower delay than expected, if the delay is set to less than at least three times of the half measuring period (at least this time is required to obtain a proper measurement)

For setting up these two parameters properly, see Chapter 2.4.3.

2.1.29.6.3. Length of the measuring halfperiods and time delay

The measuring impulses result in transients at each rising and falling edge. The length of these is related to the time constant of the circuit, related to the mentioned RC filters and RC circuits consisting of the coupling resistances and earth capacitances of the rotor. For details, see Chapter 1.1.3.

The time for the half measuring period is to be selected to leave time for these transients to decay. This can be checked in two ways:

- by using a test resistor (R_f , see the previous chapters): when the halfperiod length is too low, the measured resistance is lower than that of the test resistor.
- by creating a disturbance record manually (if the current measurements of the RAI+/11 module are added). Here, the transients can be seen in the waveforms. An example is shown below (this is made in laboratory, so on an actual generator, these transients may be much longer):

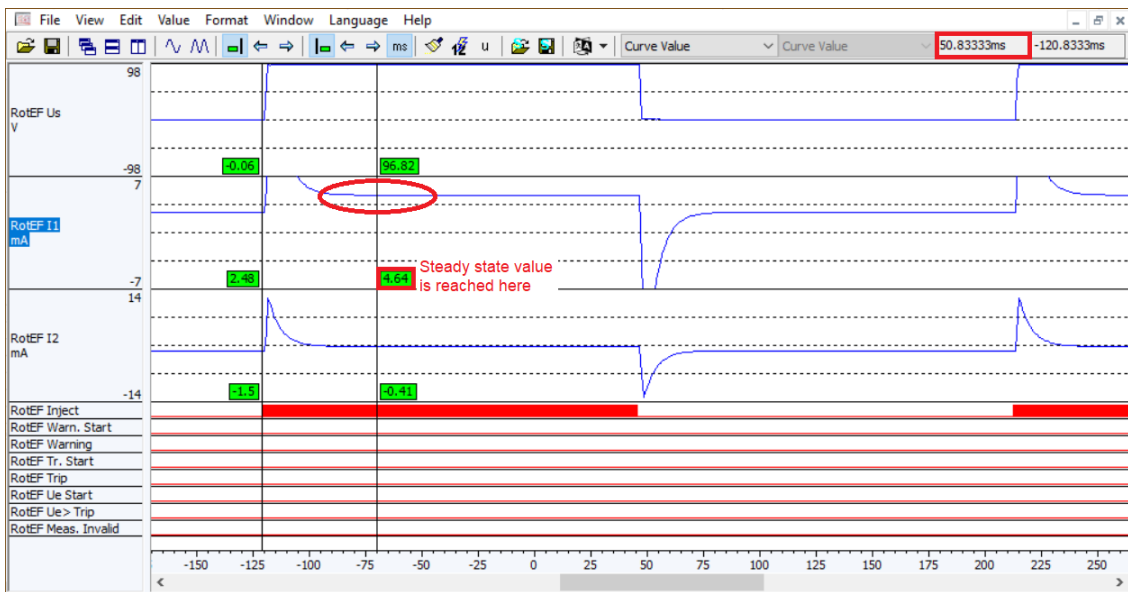

Figure 2-7 Disturbance record of the injections and measurements

The **time delay** for operation is advised to be set for the value at least **three times of the half measuring period** to bridge over a possible random short-time operation.

Taking these two into consideration, the settings of these two must be a compromise between speed and accuracy, considering the required shorter operation time – the accuracy must be good enough at the lower Ohm setting of either of the two stages' (Warning or Trip) start settings.

As an example, according to the measurements on Figure 2-7 above:

- the halfperiod length must be set to at least 3 *powercycles* ($3 \cdot 20 \text{ ms} = 60 \text{ ms}$)
- the time delays must be set to at least three times the value above: $3 \cdot 60 \text{ ms} = 180 \text{ ms}$,

which is way below the minimum setting, so they shall be set to 1000 ms.

2.1.30. Rotor earth fault protection for middle-grounded rotors

This rotor earth fault protection function (RotEFm) can be applied to provide protection against rotor earth faults in generators, where the excitation winding is grounded in the middle via the rotor body and its earthing brushes. In this arrangement, an additional contact to the ground results in a double earth fault, causing significant fault currents and vibrations in the bearing due to the flux asymmetry.

Therefore, it is necessary to detect the failure, shut down the machine and the excitation respectively.



Additionally, the calculated excitation voltage can be applied to a rotor overload protection function in the form of overvoltage detection: $U_e > t$. The time delay for this stage shall be set longer than the ceiling excitation time.

2.1.30.1. Operation principle

The algorithm is based on voltage comparison between the two halves of the rotor winding (see *Figure 1-1* below).

In static excitation applications, the controlled rectified bridge generates steep voltage peaks with three times the network frequency. Therefore, it is necessary to filter the excitation voltage with an RC circuit implemented in the coupling unit.

Due to the special construction of middle grounded rotors, the two halves of the winding may have different resistance, which results differences in the excitation voltage distribution. This kind of natural asymmetry shall be compensated with a parameter for accurate operation.

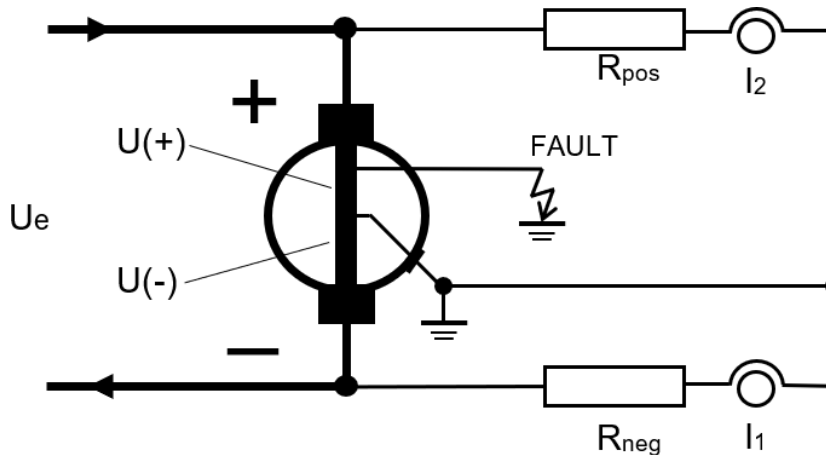

Figure 1-1 Connecting to the generator

The operation principle can be described with the following equations:

In normal operation $U(+)+U(-)+U_e \cdot A = 0$

By fault condition $U(+)+U(-)+U_e \cdot A = dU$

Where $U(+)=R_{pos} \cdot I_2$ is the voltage from the positive pole to the ground

$U(-)=R_{neg} \cdot I_1$ is the voltage from the negative pole to the ground

$U_e = U(+)-U(-)$ is the total excitation voltage between the poles

“A” is the voltage asymmetry factor expressed as a percentage of the total excitation voltage (“Asym. Voltage” parameter)

dU is the differential fault voltage, which is the criteria for pickup

2.1.30.1.1. Hardware components, coupling circuits

There is a special hardware module in the protection device, that contains the necessary hardware components for the function. The module RAI+/01 includes two galvanically isolated current inputs and the A/D converters for measured value processing.

The coupling unit (RAI+/01 BOX) includes two symmetrical circuits. One circuit connects to the positive pole and the ground, while the other circuit connects to the negative pole and the ground. The coupling unit shall be mounted externally on a din rail (see *Figure 1-2* below).

The coupling circuits consist of serial resistances, filtering condensers and voltage limiters. The sum of the serial connected resistance determines the current depending on the connected excitation voltage. Multiple connection points are available from 200V to 500V. In addition to the filtering RC circuit, the algorithm also uses a low-pass filter for the inputs.

The low-pass filter condensers in the two circuits shall have the same rating, in order to ensure equal measurement value processing with the same time constant. Otherwise, a sudden change in the excitation voltage would result in transient differences between the positive pole voltage and negative pole voltage.



Connection to the excitation circuit shall be protected by means of a fuse suitable to withstand the highest expected excitation voltage and to interrupt the maximum excitation current. If there are multiple sources for excitation (e.g. initial excitation, emergency excitation), the coupling unit shall be connected to the common output in order to make sure, that the protection works in all operational modes.

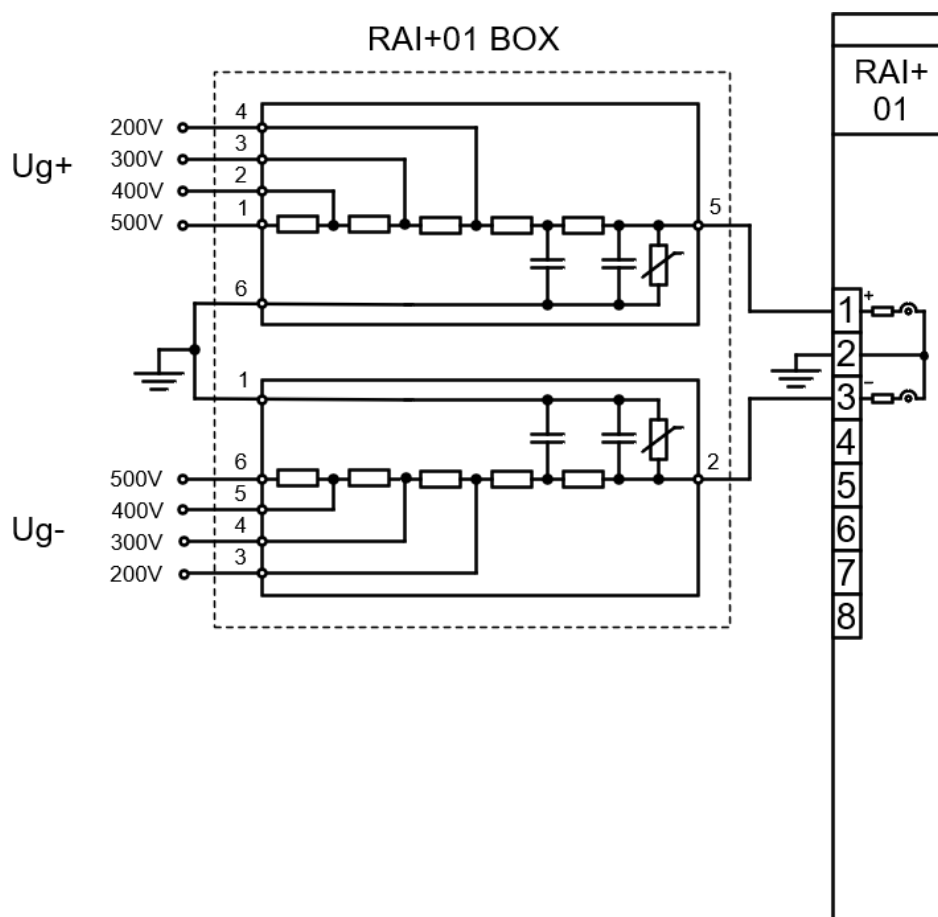

Figure 1-2 Wiring of internal (RAI+/01) and external (RAI+/01 BOX) modules

2.1.30.1.2. The properties of the measuring principle

The parallel circuits of the coupling unit transform the input voltages into measured currents. In order to express the measured and setting values in voltages, the algorithm needs the serial resistances of the coupling circuits as an input parameter. The setting value can be measured with an accurate ohm meter on the coupling unit terminations, depending on which voltage level is selected (see *Figure 1-2*). The resistance of the RAI+/01 internal module does not have to be considered here, since the algorithm automatically adds this value to the calculation.

The measuring principle is to compare the voltages on the poles. Adding the measured positive voltage to the negative will result the differential fault voltage (e.g. $U(+)=105V$ and $U(-)=-95V$, then $dU=10V$).

Due to small differences in resistance between the two halves of the rotor winding, there will be a natural voltage asymmetry, which shall be compensated during commissioning with the parameter "Asym. Voltage". This is given as a percentage of the total excitation voltage U_e . It is recommended to determine the asymmetry voltage when the excitation voltage is close to its rated value.



Example: if $U(+)=101V$ and $U(-)=-99V$, then the asymmetry is **2V**, so **-1%** shall be set).

2.1.30.2. Rotor earth fault protection function overview

The graphic appearance of the function block of the rotor earth fault protection function for middle-grounded rotors is shown below. The block shows all binary input and output status signals which are applicable in the graphic equation editor.

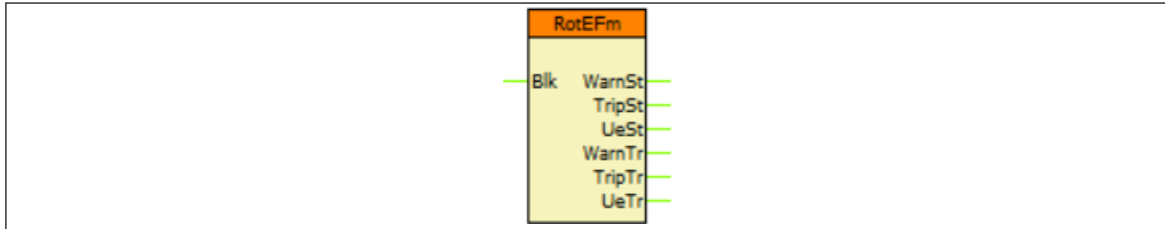

Figure 2-1 Graphic appearance of the function block of the rotor earth fault function

2.1.30.3. Settings

2.1.30.3.1. Parameters

The available parameters are listed below in order of their appearance in the *parameters* menu. If the setting range of a parameter should be extended, contact Protecta Support.

Table 2-1 Parameters of the rotor earth fault function

TITLE	DIM	RANGE	STEP	DEFAULT	EXPLANATION
Operation	-	Off, On	-	Off	Enabling the function
Ext. R Pos Side	ohm	5000 – 50000	1	17000	Exact value of the coupling resistor at the <i>positive</i> pole
Ext. R Neg Side	ohm	5000 – 50000	1	17000	Exact value of the coupling resistor at the <i>negative</i> pole
Asym. Voltage	%	-10.0 – 10.0	0.1	0.0	Asymmetry compensation (<i>related to the rated excitation voltage</i>)
Warning Start	V	0.1 – 50.0	0.1	5.0	Setting voltage value of the warning stage
Warning Delay	msec	1000 – 64000	1	2000	Time delay for the warning stage
Trip Stage Start	V	0.1 – 50.0	0.1	7.0	Setting voltage value of the trip stage
Trip Stage Delay	msec	1000 – 64000	1	2000	Time delay for the trip stage
Ue Start	V	50 – 1000	1	200	Setting voltage value for the Ue>t (excitation overvoltage) stage
Ue Delay	msec	1000 – 64000	1	2000	Time delay for the Ue>t (excitation overvoltage) stage

2.1.30.4. Function I/O

This section describes briefly the analogue and digital inputs and outputs of the function block.

2.1.30.4.1. Analogue inputs

The function uses the following analogue signals as inputs:

- Sampled values of the auxiliary voltage to be switched on the circuit
- Sampled values of the total injected current
- Sampled values of the current on the positive pole

2.1.30.4.2. Analogue outputs (measurements)

The measured values of the differential protection function are listed in the table below.

Table 2-2 The measured analogue values of the rotor earth fault function

MEASURAND NAME	TITLE	DIMENSION	EXPLANATION
RotEFm_Uepos_OLM_	Ue positive	V	Voltage on the positive pole
RotEFm_Ueneg_OLM_	Ue negative	V	Voltage on the negative pole
RotEFm_Ue_OLM_	dU	V	Differential voltage
RotEFm_Rf_OLM_	Ue	V	Total excitation voltage

2.1.30.4.3. Binary input signals (graphed output statuses)

The conditions of the binary inputs are defined by the user, applying the graphic equation editor (*Logic Editor*). Parts written in **bold** are seen on the left side function block in the Logic editor.

Table 2-3 The binary input signals of the rotor earth fault function

BINARY OUTPUT SIGNAL	EXPLANATION
RotEFm_ Blk _GrO_	Blocking input of the function

2.1.30.4.4. Binary output signals (graphed input statuses)

These signals can be used in EuroCAP to assign to LED, user LCD object etc. Parts written in **bold** are seen on the right side of the function block in the *Logic Editor*.

Table 2-4 The binary output signals of the rotor earth fault function

BINARY OUTPUT SIGNAL	SIGNAL TITLE	EXPLANATION
RotEFm_ WarnSt _Grl_	Warning Stage Start	This signal indicates starting of the warning stage
RotEFm_ TripSt _Grl_	Trip Stage Start	This signal indicates starting of the trip stage
RotEFm_ UeSt _Grl_	Ue Start	This signal indicates starting of the Ue> stage
RotEFm_ WarnTr _Grl_	Warning Stage Delay	This signal indicates timeout of the warning stage
RotEFm_ TripTr _Grl_	Trip Stage Delay	This signal indicates timeout of the trip stage
RotEFm_ UeTr _Grl_	Ue Trip	This signal indicates timeout of the Ue> stage



2.1.30.4.5. Online data

Visible values on the on-line data page:

Table 2-5 Online displayed data of the rotor earth fault function

SIGNAL TITLE	DIMENSION	EXPLANATION
Ue positive	V	Voltage on the positive pole
Ue negative	V	Voltage on the negative pole
dU	V	Differential voltage
Ue	V	Total excitation voltage
Warning Stage Start	-	This signal indicates starting of the warning stage
Warning Stage Delay	-	This signal indicates timeout of the warning stage
Trip Stage Start	-	This signal indicates starting of the trip stage
Trip Stage Delay	-	This signal indicates timeout of the trip stage
Ue Start	-	This signal indicates starting of the Ue> stage
Ue Trip	-	This signal indicates timeout of the Ue> stage

2.1.30.4.6. Events

The following events are generated in the event list, as well as sent to SCADA according to the configuration.

Table 2-6 Generated events of the rotor earth fault function

EVENT	VALUE	EXPLANATION
Warning Stage Start	off, on	Starting of the warning stage
Trip Stage Start	off, on	Starting of the trip stage
Ue Start	off, on	Starting of the Ue> stage
Warning Stage Delay	off, on	Timeout of the warning stage
Trip Stage Delay	off, on	Timeout of the trip stage
Ue Trip	off, on	Timeout of the Ue> stage

2.1.30.5. Technical data

Table 2-7 Technical data of the rotor earth fault function

FUNCTION	VALUE	ACCURACY
Voltage asymmetry	0.1-50V	±5%
Excitation voltage	50 – 1000 V	±5%
Operating time*	40 ms	+40 -20 ms
Reset time*	40 ms	+40 -20 ms
Reset ratio for dU>	0,9	
Reset ratio for Ue>	0,9	
Timer (started at fault detection)		±20 ms

*The operating and reset time are referring to the algorithm only. The time constant of the low-pass filter in the coupling unit shall also be considered according to Figure 2-2 and Figure 2-3.

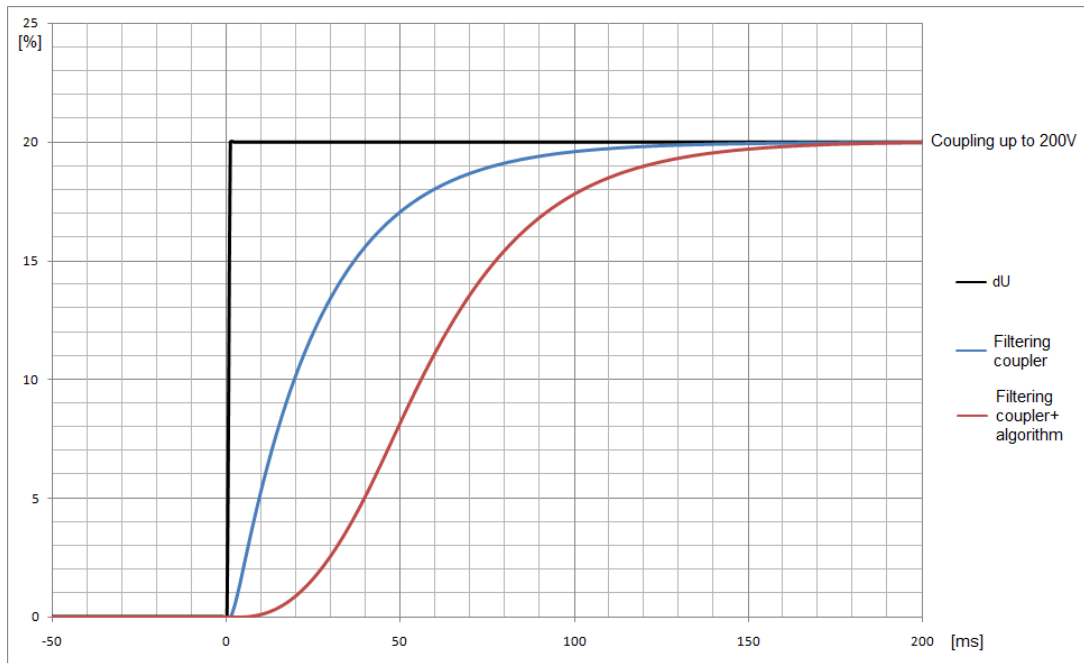

Figure 2-2 Filtering the analogue input with a coupler connected for 200V

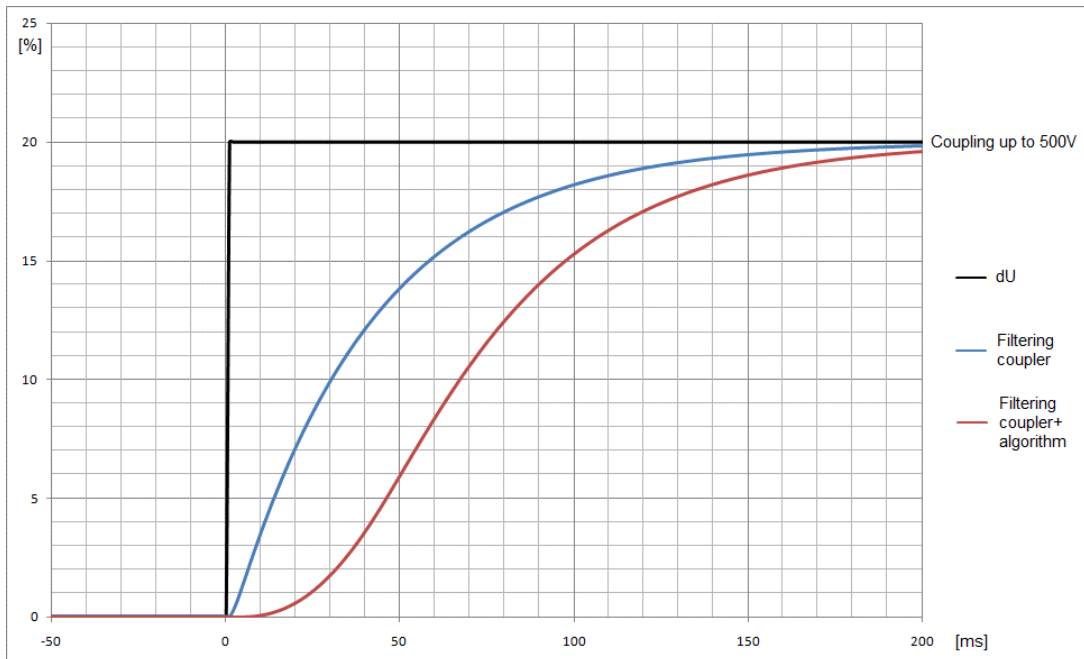
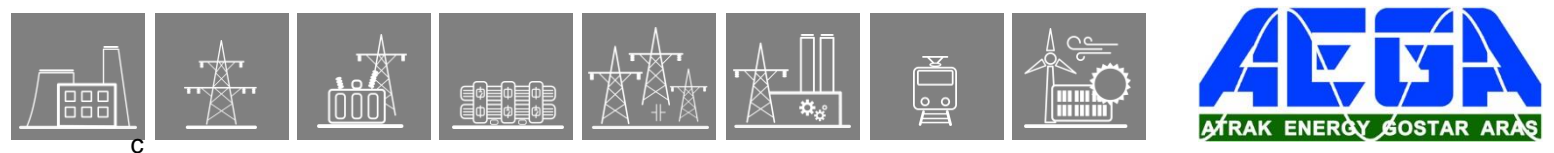

Figure 2-3 Filtering the analogue input with a coupler connected for 500V



2.1.30.6. Notes for testing

Normally in the EuroProt+ devices the trip contacts are assigned to the Trip Logic function block, and not to the protection function blocks. Because of this, the testing personnel must make sure that the Trip Logic is switched on ('Operation' parameter is set to other than 'Off') before starting the tests, otherwise there will be no physical trip on the relay.

2.1.31. Inrush current detection function

2.1.31.1. Application

When an inductive element with an iron core (transformer, reactor, etc.) is energized, high current peak values can be detected. This is caused by the transient asymmetric saturation of the iron core as a nonlinear element in the power network. The sizing of the iron core is usually sufficient to keep the steady state magnetic flux values below the saturation point of the iron core, so the inrush transient slowly dies out. These current peaks depend also on random factors such as the phase angle at energizing. Depending on the shape of the magnetization curve of the iron core, the detected peaks can be several times above the rated current peaks. Additionally, in medium or high voltage networks, where losses and damping are low, the indicated high current values may be sustained at length. Figure 1-1 shows a typical example for the inrush current shapes of a three-phase transformer.

As a consequence, overcurrent relays, differential relays or distance relays may start, and because of the long duration of the high current peaks, they may generate an unwanted trip command.

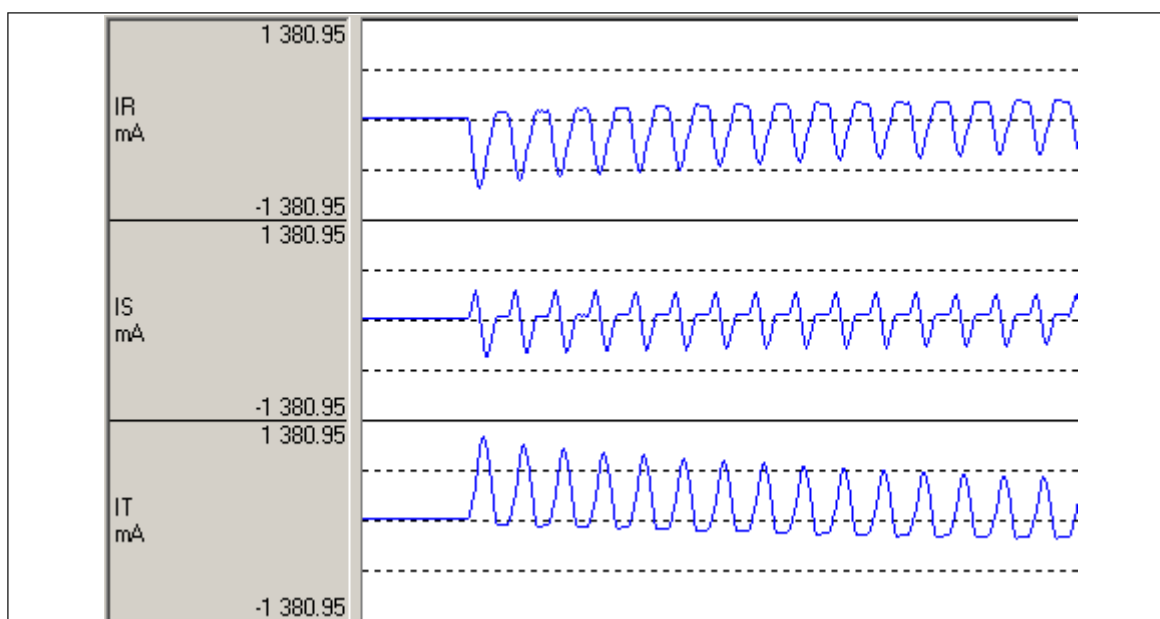

Figure 1-1 Example: A typical inrush current

The inrush current detection function can distinguish between high currents caused by overload or faults and the high currents during the inrush time.

Using the inrush detection binary signals, other protection functions can be blocked during the transient period so as to avoid the unwanted trip.

Some protection functions use these signals automatically, but a stand-alone inrush detection function block is also available for application at the user's discretion.

2.1.31.2. Inrush current detection function overview

The function block of the inrush current detection function is shown in Figure 2-1. This block shows all binary input and output status signals that are applicable in the graphic equation editor.

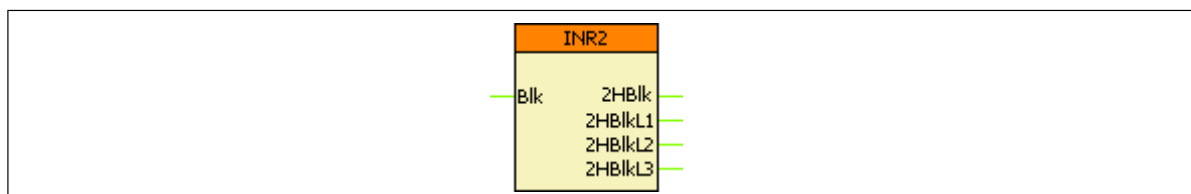

Figure 2-1 The function block of the inrush current detection function

2.1.31.2.1. Settings

2.1.31.2.1.1. Parameters

The available parameters are listed below in order of their appearance in the *parameters* menu. If the setting range of a parameter should be extended, contact Protecta Support.

Table 2-1 Parameters of the inrush current detection function

TITLE	DIM	RANGE	STEP	DEFAULT	EXPLANATION
Operation	-	Off, On	-	Off	Enabling the function
2 nd Harm Ratio	%	5 – 50	1	15	Ratio of the second harmonic Fourier component and the basic harmonic component.
IPh Base Sens	%	20 – 100	1	30	The function operates only if the base harmonic component is be above this setting

2.1.31.2.2. Function I/O

This section briefly describes the analogue and digital inputs and outputs of the function block.

2.1.31.2.2.1. Analogue inputs

The basic and second Fourier components of three phase currents.

2.1.31.2.2.2. Binary input signals (graphed output statuses)

The conditions of the binary inputs are defined by the user, applying the graphic equation editor (*Logic Editor*). Parts written in **bold** are seen on the left side function block in the Logic editor.

Table 2-2 The binary input signal of the inrush current detection function

BINARY INPUT SIGNAL	EXPLANATION
INR2_ Bik _GrO_	Blocking input of the function

2.1.31.2.2.3. Binary output signals (graphed input statuses)

These signals can be used in EuroCAP to assign to LED, user LCD object etc. Parts written in **bold** are seen on the right side of the function block in the *Logic Editor*.

Table 2-3 The binary output signals of the inrush current detection function

BINARY OUTPUT SIGNAL	SIGNAL TITLE	EXPLANATION
INR2_ 2HBik _GrI_	Inrush	Inrush current detected in one of the three phases
INR2_ 2HBikL1 _GrI_	Inrush L1	Inrush current detected in phase L1
INR2_ 2HBikL2 _GrI_	Inrush L2	Inrush current detected in phase L2
INR2_ 2HBikL3 _GrI_	Inrush L3	Inrush current detected in phase L3

2.1.31.2.2.4. Online data

Visible values on the *online data* page.

Table 2-4 Online displayed data of the inrush current detection function

SIGNAL TITLE	DIMENSION	EXPLANATION
Inrush L1	-	Inrush current detected in phase L1
Inrush L2	-	Inrush current detected in phase L2
Inrush L3	-	Inrush current detected in phase L3
Inrush	-	Inrush current detected in one of the three phases

2.1.31.2.2.5. Events

The following events are generated in the event list, as well as sent to the SCADA according to the configuration.

Table 2-5 Generated events of the inrush current detection function

EVENT	VALUE	EXPLANATION
2 nd Harm. Restraint	off, on	Inrush current detected in one of the three phases

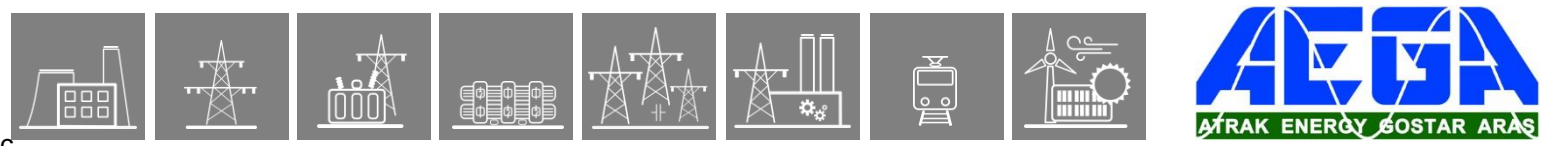

2.1.31.2.3. Technical data

Table 2-6 Technical data of the inrush current detection function

FUNCTION	VALUE	ACCURACY
Current accuracy	20 – 2000% of I_n	$\pm 1\%$ of I_n

2.1.31.2.4. Notes for testing

The differential protection function block (DIF87) has its own, built-in 2nd harmonic restraint feature which works independently from the function described here. For further information, see the Differential Protection Function description.

Keep in mind that there is a minimum requirement for the fundamental component of the current (% is the % of the CT nominal), and the function operates according to the 2nd harmonic content related to the fundamental component.

2.1.32. Pole Slipping Protection

2.1.32.1. Application

2.1.32.1.1. Field of Application

The pole slipping protection function can be applied mainly for synchronous generators. If a generator falls out of synchronism, then the voltage vector induced by the generator rotates slower or with a higher speed as compared to voltage vectors of the network. The result is that according to the frequency difference of the two vector systems, the cyclical voltage difference on the current carrying elements of the network are overloaded cyclically. To protect the stator coils from the harmful effects of the high currents and to protect the network elements, a disconnection is required.

The pole slipping protection function is designed for this purpose.

2.1.32.1.2. Principle of Operation

The principle of operation is the impedance calculation.

When a generator falls out of synchronism, then the voltage vector induced by the generator rotates slower or with a higher speed as compared to voltage vectors of the network. The result is that according to the frequency difference of the two vector systems the cyclical voltage difference on the current carrying elements of the network draws cyclically high currents. The calculated impedance moves along lines "Pole slipping" as it is indicated in Figure 1-1 on the impedance plane. (The stable swings return to the same quadrant of the impedance plane along lines "Stable swing".)

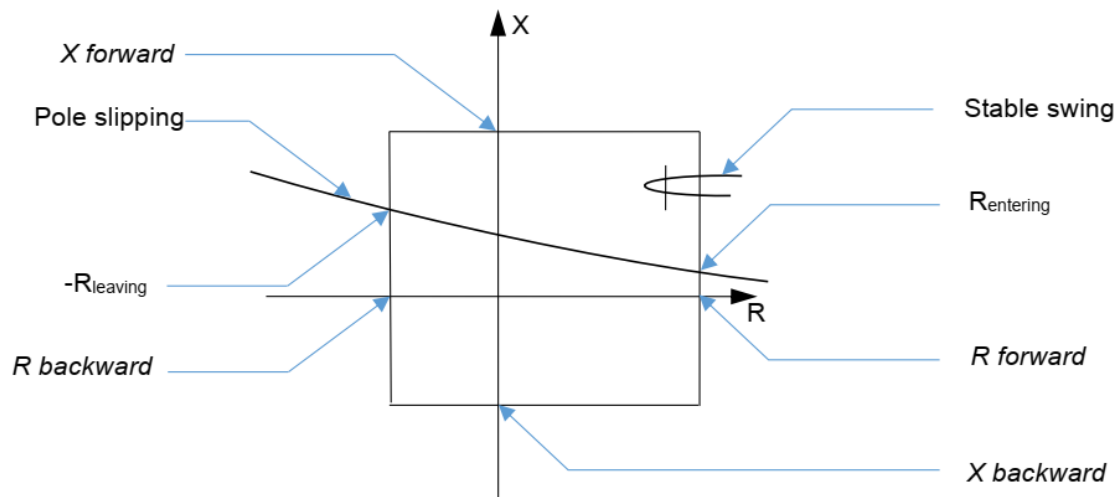

Figure 1-1 Pole slipping

The characteristic feature of pole slipping is that the impedance locus leaves the characteristic at a location, where the sign of the calculated resistance (e.g. $-R_{leaving}$) is opposite to that of the entering location (e.g. $+R_{entering}$).

If basically other protections on the network are expected to stop the pole slipping, then more than one vector revolution is permitted. In this case the number of the revolutions – defined by the *Max Cycle Number* parameter – can be set higher than 1, and the subsequent revolution is expected within a defined *Dead Time*, also set by parameter.

The duration of the generated trip pulse is set by the parameter *Pulse Duration*.

2.1.32.1.3. Main Features

The main features of the pole slipping protection function are as follows:

- A full-scheme system provides continuous measurement of impedances separately in three independent phase-to-phase measuring loops.
- Impedance calculation is conditional on the values of the positive sequence currents being above a defined value.
- A further condition of the operation is that the negative sequence current component is less than 1/6 of the value defined for the positive sequence component.
- The operate decision is based on quadrilateral characteristics on the impedance plane using four setting parameters.
- The number of vector revolutions can be set by a parameter.
- The duration of the trip signal is set by a parameter.
- Blocking/enabling binary input signal can influence the operation.

2.1.32.1.4. Structure of the Pole Slipping Protection

Figure 1-2 shows the structure of the pole slipping protection function with quadrilateral characteristic. The impedance calculation is made by an external, impedance-based protection function in the same configuration (underexcitation, distance or impedance protection):

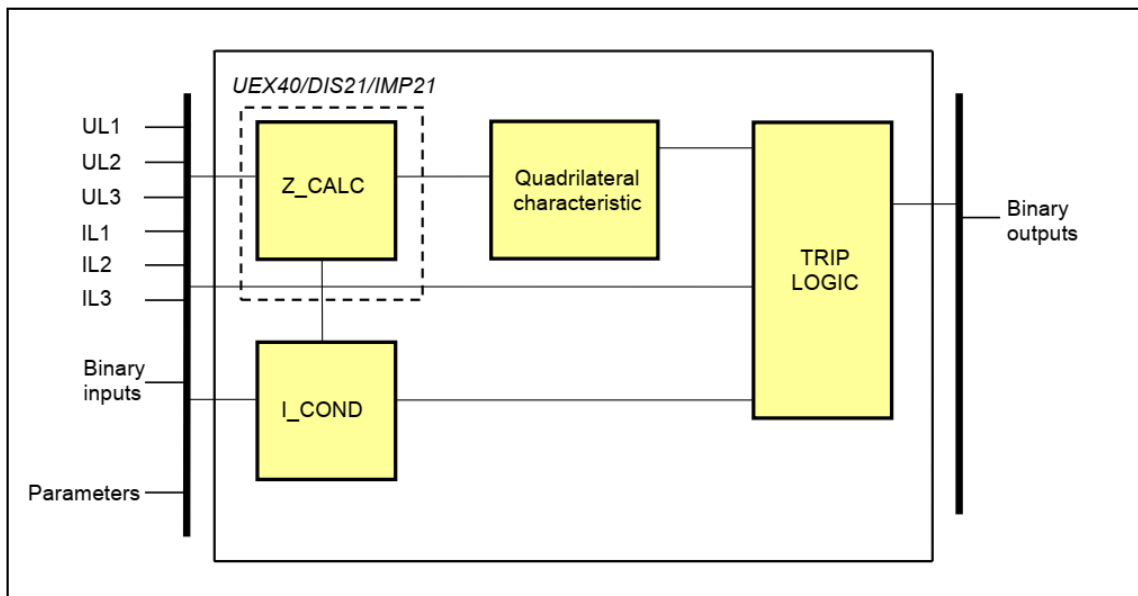

Figure 1-2 Structure of the pole slipping protection algorithm

The **inputs** are

- the Fourier components of three phase voltages (indirectly),
- the Fourier components of three phase currents (indirectly),
- binary inputs,
- parameters.

The **outputs** are

- the binary output status signals,

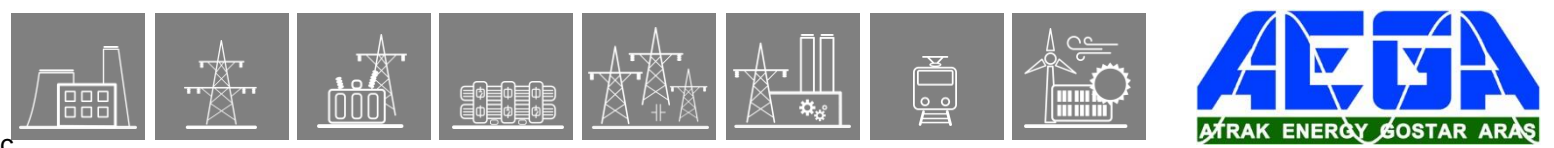

The **software modules** of the pole slipping protection function are as follows:

Z_CALC	calculates the impedances ($R + jX$) of the three phase-phase measuring current loops (external function)
Quadrilateral characteristic	compares the calculated impedances with the setting values of the quadrilateral characteristics. The result is the decision for all three measuring loops if the impedance is within the offset circle.
TRIP LOGIC	is the algorithm to decide to generate the trip command.
I_COND	calculates the current conditions necessary for the impedance calculation.

In the following sections, the details of the individual components are explained.

2.1.32.1.5.3. The Principal Scheme of the Impedance Calculation

Figure 1-3 shows the principal scheme of the impedance calculation Z_CALC.

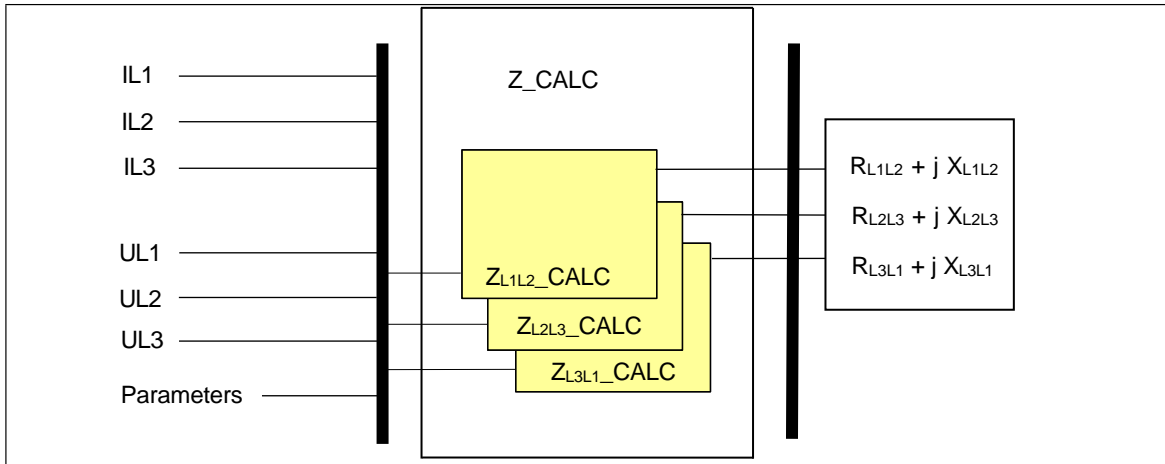

Figure 1-3 Principal scheme of the impedance calculation Z_CALC

The **inputs** are the Fourier components of:

- the Fourier components of three phase voltages,
- the Fourier components of three phase currents,
- parameters.

The **outputs** are the calculated positive sequence impedances (R+ jX) of the three measuring loops:

- Impedances of the three phase-to-phase loops.

Table 1-2 The measured (calculated) values of the Z_CALC module

CALCULATED VALUE	DIM.	EXPLANATION
$RL1L2 + j XL1L2$	ohm	Measured positive sequence impedance in the L1L2 loop
$RL2L3 + j XL2L3$	ohm	Measured positive sequence impedance in the L2L3 loop
$RL3L1 + j XL3L1$	ohm	Measured positive sequence impedance in the L3L1 loop

Z_CALC includes three practically identical software modules for impedance calculation:

- The three routines for the phase-to-phase loops get line-to-line voltages calculated from the sampled phase voltages and they get differences of the phase currents.

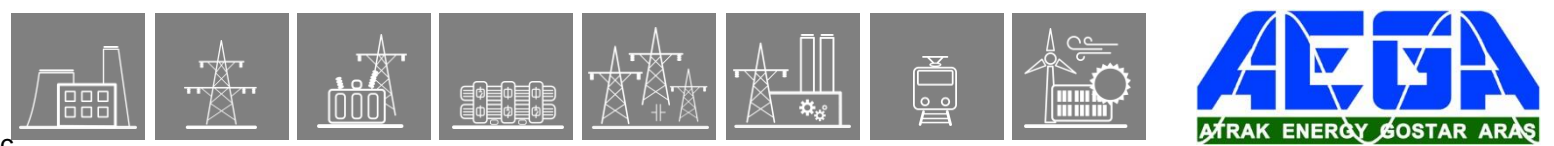

The parameters needed in the characteristic evaluation procedure of the pole slip function are explained in the following Tables.

Table 1-5 The integer parameter of the quadrilateral characteristic module

TITLE	DIM	RANGE	STEP	DEFAULT	EXPLANATION
Max Cycle Number	cycle	1 – 10	1	1	Definition for the number of the vector revolutions before a trip command

Table 1-6 The float parameters of the quadrilateral characteristic module

TITLE	DIM	RANGE	STEP	DEFAULT	EXPLANATION
R forward	ohm	0.10 – 150.00	0.01	10.00	R setting of the impedance characteristics in forward direction
X forward	ohm	0.10 – 150.00	0.01	10.00	X setting of the impedance characteristics in forward direction
R backward	ohm	0.10 – 150.00	0.01	10.00	R setting of the impedance characteristics in backward direction
X backward	ohm	0.10 – 150.00	0.01	10.00	X setting of the impedance characteristics in backward direction

Table 1-7 The timer parameter of the quadrilateral characteristic module

TITLE	DIM	RANGE	STEP	DEFAULT	EXPLANATION
Dead Time	msec	100 – 60000	1	5000	Time delay for waiting for a subsequent revolution if the <i>Max Cycle Number</i> parameter is set to more than 1

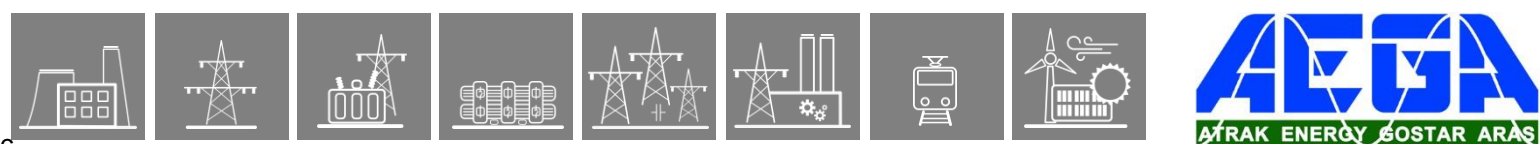

2.1.32.1.7. The Trip Logic (TRIP LOGIC) and Timing

The trip logic module determines the decision to generate the trip command. The condition is that at least two out of three phase-to-phase loops detect pole slip in a number required by parameter setting while the function is not blocked or disabled.

The duration of the trip pulse is defined by parameter setting.

Table 1-8 The enumerated parameter of the trip logic

TITLE	DIM	RANGE	STEP	DEFAULT	EXPLANATION
Operation	-	Off, On	-	Off	Parameter for disabling the function.

Table 1-9 Timer parameter of the trip logic

TITLE	DIM	RANGE	STEP	DEFAULT	EXPLANATION
Pulse Duration	msec	50 – 10000	1	150	Generated trip impulse duration

Table 1-10 Binary input values of the trip logic

INPUT VALUES	EXPLANATION
<i>Operation signals from the quadrilateral characteristic module (these signals are not published)</i>	
PsL1L2_1	The impedance in the fault loop L1L2 performed the given number of pole slips
PsL2L3_1	The impedance in the fault loop L2L3 performed the given number of pole slips
PsL3L1_1	The impedance in the fault loop L3L1 performed the given number of pole slips
<i>Impedance function start conditions generated by the I_COND module (these signals are also not published)</i>	
PSLIP78_cL1_GrI_	The current in phase L1 is sufficient for impedance calculation
PSLIP78_cL2_GrI_	The current in phase L2 is sufficient for impedance calculation
PSLIP78_cL3_GrI_	The current in phase L3 is sufficient for impedance calculation

Table 1-11 Binary output status signals of the trip logic

BINARY OUTPUT SIGNAL	SIGNAL TITLE	EXPLANATION
PSLIP78_Start_GrI_	Start	Start signal of the function
PSLIP78_Trip_GrI_	Trip	Trip command of the function

Table 1-12 The binary input status signal of the trip logic

BINARY INPUT SIGNAL	SIGNAL TITLE	EXPLANATION
PSLIP78_Blk_GrO_	Block	Blocking of the pole slipping function

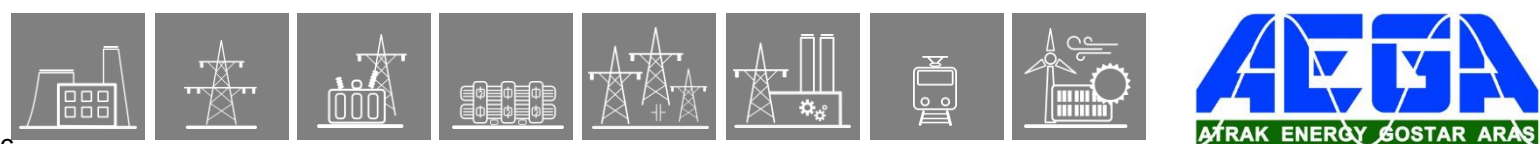

2.1.32.1.8. The Current Conditions of the Pole Slip Protection Function (I_COND)

The pole slip protection function can operate only if the positive sequence current component is above a certain value, defined for by a parameter value. A further condition of the operation is that the negative sequence current component is less than 1/6 of the value defined for the positive sequence component. This condition excludes the operation in case of asymmetrical faults. This module performs this preliminary decision.

Table 1-13 The binary output status signals of the current conditions module

BINARY OUTPUT SIGNAL	SIGNAL TITLE	EXPLANATION
<i>Impedance function start conditions generated by the I_COND module (these signals are not published)</i>		
PSLIP78_cIL1_Grl_	I L1 condition	The current in phase L1 is sufficient for impedance calculation
PSLIP78_cIL2_Grl_	I L2 condition	The current in phase L2 is sufficient for impedance calculation
PSLIP78_cIL3_Grl_	I L3 condition	The current in phase L3 is sufficient for impedance calculation

Table 1-14 Integer parameter for the current conditions module

TITLE	DIM	RANGE	STEP	DEFAULT	EXPLANATION
I1 Low Limit	%	50 – 200	1	120	Definition of minimal current enabling impedance calculation

The positive sequence current is considered to be sufficient if it is above the level set by the parameter *I1 Low Limit*. At the same time the negative sequence component should be below 1/6 of this parameter value.

2.1.32.2. Pole Slipping Protection Function Overview

The graphic appearance of the pole slipping protection function block is shown in Figure 2-1. This block shows all binary input and output status signals that are applicable in the graphic equation editor.

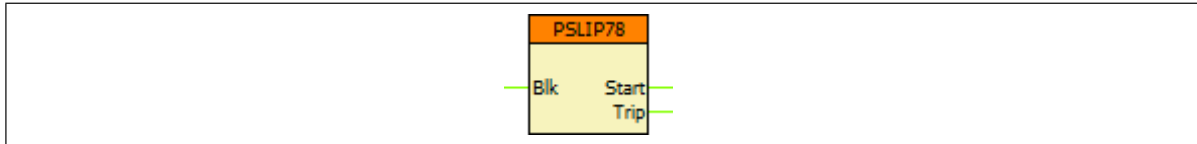

Figure 2-1 The function block of the pole slipping protection function

2.1.32.2.1. Settings

2.1.32.2.1.1. Parameters

The available parameters are listed below in order of their appearance in the *parameters* menu. If the setting range of a parameter should be extended, contact Protecta Support.

Table 2-1 Parameters of the pole slipping protection function

TITLE	DIM	RANGE	STEP	DEFAULT	EXPLANATION
Operation	-	Off, On	-	Off	Parameter for disabling or enabling the operation of the function.
Max Cycle Number	cycle	1 – 10	1	1	Definition for the number of the vector revolutions before sending a trip command
I1 Low Limit	%	50 – 200	1	120	Definition of minimal current enabling impedance calculation
R forward	ohm	0.10 – 150.00	0.01	10.00	R setting of the impedance characteristics in forward direction
X forward	ohm	0.10 – 150.00	0.01	10.00	X setting of the impedance characteristics in forward direction
R backward	ohm	0.10 – 150.00	0.01	10.00	R setting of the impedance characteristics in backward direction
X backward	ohm	0.10 – 150.00	0.01	10.00	X setting of the impedance characteristics in backward direction
Dead Time	msec	100 – 60000	1	5000	Time delay for waiting the subsequent revolution
Pulse Duration	msec	50 – 10000	1	150	Generated trip pulse duration

2.1.32.2.2. Function I/O

This section briefly describes the analogue and digital inputs and outputs of the function block.

2.1.32.2.2.1. Analogue Inputs

The analogue inputs of the function are the L1L2, L2L3 and the L3L1 loop impedance values.

2.1.32.2.2.2. Binary Input Signals (Graphed Output Statuses)

The conditions of the binary inputs are defined by the user, applying the graphic equation editor (*Logic Editor*). Parts written in **bold** are seen on the left side of the function block in the Logic editor.

Table 2-2 The binary input signals of the pole slipping protection function

BINARY INPUT SIGNAL	SIGNAL TITLE	EXPLANATION
PSLIP78_ Bik _GrO_	Block	Input for disabling the function

2.1.32.2.2.3. Binary Output Signals (Graphed Input Statuses)

These signals can be used in EuroCAP to assign to LED, user LCD object etc. Parts written in **bold** are seen on the right side of the function block in the *Logic Editor*.

Table 2-3 The binary output signals of the pole slipping protection function

BINARY OUTPUT SIGNAL	SIGNAL TITLE	EXPLANATION
PSLIP78_ Start _Grl_	Start	Start signal of the function
PSLIP78_ Trip _Grl_	Trip	Trip command of the function

2.1.32.2.2.4. Online Data

The following values are visible in the *online data* page.

Table 2-4 Online data of the pole slipping protection function

SIGNAL TITLE	DIMENSION	EXPLANATION
Start	-	Start signal of the function
Trip	-	Trip command of the function

2.1.32.2.2.5. Events

The following events are generated in the event list, as well as sent to the SCADA according to the configuration.

Table 2-5 Generatable events of the pole slipping protection function

EVENT	VALUE	EXPLANATION
Start	off, on	Start signal of the function
Trip	off, on	Trip command of the function

2.1.32.2.3. Technical Data

Table 2-6 Technical data of the pole slipping protection function

FUNCTION	VALUE	ACCURACY
Rated current, I_n	1/5A, parameter setting	
Rated Voltage, U_n	100/200V, parameter setting	
Current effective range	20 – 2000% of I_n	$\pm 1\%$ of I_n
Voltage effective range	2 – 110% of U_n	$\pm 1\%$ of U_n
Impedance effective range $I_n=1A$ $I_n=5A$	0.1 – 200 Ohm 0.1 – 40 Ohm	$\pm 5\%$
Zone static accuracy	48 Hz – 52 Hz 49.5 Hz – 50.5 Hz	$\pm 5\%$ $\pm 2\%$
Operate time	Typically 25 ms	± 3 ms
Minimum operate time	< 20 ms	
Reset time	16 – 25 ms	

2.1.32.2.4. Notes for Testing

The impedance trajectory must be created in a way that the impedance vector starts out of the characteristics, enters the rectangle from right side, and leaves it on the left side.

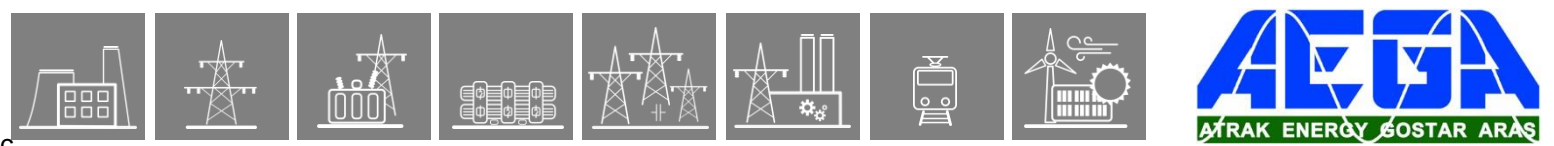

2.1.33. Over-frequency protection function

2.1.33.1. Application

The deviation of the frequency from the rated system frequency indicates unbalance between the generated power and the load demand. If the available generation is large compared to the consumption by the load connected to the power system, then the system frequency is above the rated value. The overfrequency protection function is usually applied to decrease generation to control the system frequency.

Another possible application is the detection of unintended island operation of distributed generation and some consumers. In the island, there is low probability that the power generated is the same as the consumption; accordingly, the detection of high frequency can be one of the indications of island operation.

2.1.33.1.1. Mode of operation

Depending on the hardware-software configuration, the frequency measurement is usually based on channel No. 1 (line voltage) and channel No. 4 (busbar voltage) of any voltage input module.

The accurate frequency measurement is performed by measuring the time period between two rising edges and also between two falling edges at zero crossing of a voltage signal. The frequency value is calculated by the average of these two values. At each zero crossing the average value (and the frequency) is recalculated.

For the acceptance of the measured frequency, at least four subsequent valid measurements are needed. Similarly, four invalid measurements are needed to reset the measured frequency from the last valid value to zero.

The minimum voltage condition can be set as a parameter for enabling the evaluation of the frequency. This parameter is called U limit.

The overfrequency protection function generates a start signal if at least five measured frequency values are above the preset level.

2.1.33.2. Overfrequency protection function overview

The graphic appearance of the function block of the overfrequency protection function is shown below. The block shows all binary input and output status signals which are applicable in the graphic equation editor.

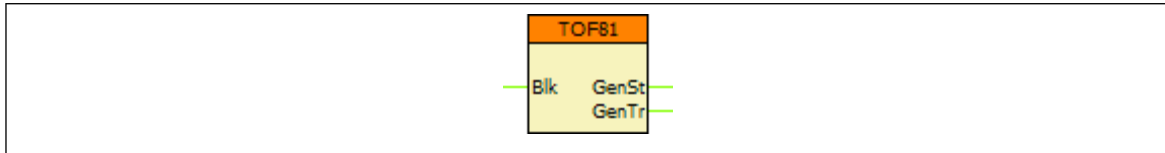

Figure 2-1 Graphic appearance of the function block of the overfrequency protection function

2.1.33.2.1. Settings

2.1.33.2.1.1. Parameters

The available parameters are listed below in order of their appearance in the *parameters* menu. If the setting range of a parameter should be extended, contact Protecta Support.

Table 2-1 Parameters of the overfrequency protection function

TITLE	DIM	RANGE	STEP	DEFAULT	EXPLANATION
Operation	-	Off, On	-	Off	Enabling the function
Start Signal Only	-	FALSE, TRUE	-	FALSE	Enabling start signal only
Start Frequency	Hz	40.00 – 70.00	0.01	51.00	Setting value of the comparison
U limit	-	0.1Un – 1Un	0.01	0.45	Minimum voltage condition for enabling the operation of the function
Time Delay	msec	140* – 10000	1	200	Time delay (including the algorithm time, see Chapter 2.4 for more explanation)

*The minimum operate time is lower than the settable minimum delay, however below this value the timing is less accurate, see Chapter 2.3 for details

2.1.33.2.2. Function I/O

This section describes briefly the analogue and digital inputs and outputs of the function block.

2.1.33.2.2.1. Analogue inputs

The function uses the sampled values of a voltage input or a calculated line-to-line voltage. This is defined in the configuration.

2.1.33.2.2.2. Analogue outputs (measurements)

The frequency measurement is displayed *MXU_F* – frequency measurement function which is an independent function.

2.1.33.2.2.3. Binary input signals (graphed output statuses)

The conditions of the binary inputs are defined by the user, applying the graphic equation editor (*Logic Editor*). Parts written in **bold** are seen on the left side function block in the *Logic editor*.

Table 2-2 The binary input signal of the overfrequency protection function

BINARY OUTPUT SIGNAL	EXPLANATION
TOF81_ Bik _GrO_	Blocking input of the function

2.1.33.2.2.4. Binary output signals (graphed input statuses)

These signals can be used in EuroCAP to assign to LED, user LCD object etc. Parts written in **bold** are seen on the right side of the function block in the *Logic Editor*.

Table 2-3 The binary output signals of the overfrequency protection function

BINARY OUTPUT SIGNAL	SIGNAL TITLE	EXPLANATION
TOF81_ GenSt _Grl_	General Start	General start signal of the function
TOF81_ GenTr _Grl_	General Trip	General trip command of the function

2.1.33.2.2.5. Online data

Visible values on the *online data* page.

Table 2-4 Online displayed data of the overfrequency protection function

SIGNAL TITLE	DIMENSION	EXPLANATION
General Start	-	General start signal of the function
General Trip	-	General trip command of the function

2.1.33.2.2.6. Events

The following events are generated in the event list, as well as sent to the SCADA according to the configuration.

Table 2-5 Generated events of the overfrequency protection function

EVENT	VALUE	EXPLANATION
General Start	off, on	General start of the function
General Trip	off, on	General trip command of the function

2.1.33.2.3. Technical data

The technical data, except for the min. operate voltage, are based on the function block testing according to the directives of the **IEC 60255-181:2019** standard.

Table 2-6 Technical data of the overfrequency protection function

FUNCTION	VALUE	ACCURACY
Operate range	40 - 60 Hz (50 Hz system) 50 - 70 Hz (60 Hz system)	± 3 mHz (20 mHz*)
Effective range	45 - 55 Hz (50 Hz) 55 - 65 Hz (60 Hz)	± 3 mHz (10 mHz*)
Min. operate time	93 ms (50 Hz) 73 ms (60 Hz)	± 32 ms ± 27 ms
Time delay	140 – 60000 ms <140 ms (50 Hz) <140 ms (60 Hz)	± 4 ms ± 32 ms ± 27 ms
Reset frequency	[Start freq.] – 101 mHz	± 1 mHz
Reset time	98 ms (50 Hz) 85 ms (60 Hz)	± 6 ms
Reset ratio for U limit	0.8	

**with the harmonic content according to the standard*

2.1.33.2.4. Notes for testing

Normally in the EuroProt+ devices the trip contacts are assigned to the Trip Logic function block, and not to the protection function blocks. Because of this, the testing personnel must make sure that the Trip Logic is switched on ('Operation' parameter is set to other than 'Off') before starting the tests, otherwise there will be no physical trip on the relay.

Note that the time delay parameter incorporates the algorithm time as well, so the time delay *does not mean the time difference between the appearance of the start and trip signals* of the function. In other words: it is not the delay between the detection of the fault and the trip that follows it. This should be taken into consideration when checking the disturbance records.

Instead the time delay parameter defines the elapsed time from the appearance of the faulty state to the trip. Because of this, while testing, the delay measurement should start *from the moment of the fault injection* until the trip signal.

The source voltage for frequency measurement is defined by the voltage input of the functionblock. This can be checked in the functionblock properties in EuroCAP

Before the fault injection at least 1 second pre-fault should be simulated with nominal frequency and voltage.

Based on IEC 60255-181 standard recommendations, the operation time shall be measured with a frequency of 0.5Hz higher than the setting value for Start frequency.

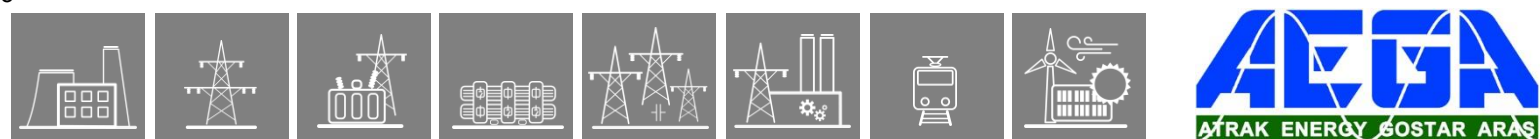

2.1.34. Underfrequency protection function

2.1.34.1. Application

The deviation of the frequency from the rated system frequency indicates unbalance between the generated power and the load demand. If the available generation is small compared to the consumption by the load connected to the power system, then the system frequency is below the rated value. The underfrequency protection function is usually applied to increase generation or for load shedding to control the system frequency.

Another possible application is the detection of unintended island operation of distributed generation and some consumers. In the island, there is low probability that the power generated is the same as the consumption; accordingly, the detection of low frequency can be one of the indications of island operation.

2.1.34.1.1. Mode of operation

Depending on the hardware-software configuration, the frequency measurement is usually based on channel No. 1 (line voltage) and channel No. 4 (busbar voltage) of any voltage input module.

The accurate frequency measurement is performed by measuring the time period between two rising edges and also between two falling edges at zero crossing of a voltage signal. The frequency value is calculated by the average of these two values. At each zero crossing the average value (and the frequency) is recalculated.

For the acceptance of the measured frequency, at least four subsequent valid measurements are needed. Similarly, four invalid measurements are needed to reset the measured frequency from the last valid value to zero.

The minimum voltage condition can be set as a parameter for enabling the evaluation of the frequency. This parameter is called U limit.

The underfrequency protection function generates a start signal if at least five measured frequency values are below the preset level.

2.1.34.2. Underfrequency protection function overview

The graphic appearance of the function block of the underfrequency protection function is shown below. The block shows all binary input and output status signals which are applicable in the graphic equation editor.

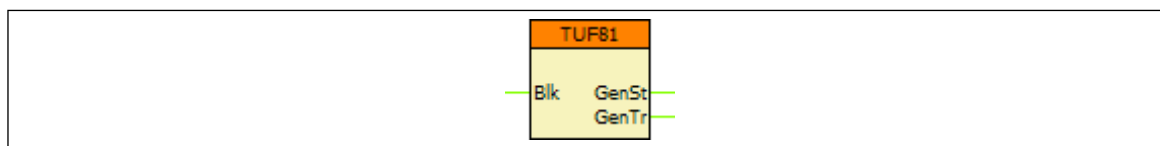

Figure 2-1 Graphic appearance of the function block of the underfrequency protection function

2.1.34.2.1. Settings

2.1.34.2.1.1. Parameters

The available parameters are listed below in order of their appearance in the *parameters* menu. If the setting range of a parameter should be extended, contact Protecta Support.

Table 2-1 Parameters of the underfrequency protection function

TITLE	DIM	RANGE	STEP	DEFAULT	EXPLANATION
Operation	-	Off, On	-	Off	Enabling the function
Start Signal Only	-	FALSE, TRUE	-	FALSE	Enabling start signal only
Start Frequency	Hz	40.00 – 70.00	0.01	49.00	Setting value of the comparison
U limit	-	0.1Un – 1Un	0.01	0.45	Minimum voltage condition for enabling the operation of the function
Time Delay	msec	140* – 10000	1	200	Time delay (including the algorithm time, see Chapter 2.4 for more explanation)

*The minimum operate time is lower than the settable minimum delay, however below this value the timing is less accurate, see Chapter [2.3](#) for details

2.1.34.2.2. Function I/O

This section describes briefly the analogue and digital inputs and outputs of the function block.

2.1.34.2.2.1. Analogue inputs

The function uses the sampled values of a voltage input or a calculated line-to-line voltage. This is defined in the configuration.

2.1.34.2.2.2. Analogue outputs (measurements)

The frequency measurement is displayed *MXU_F* – frequency measurement function which is an independent function.

2.1.34.2.2.3. Binary input signals (graphed output statuses)

The conditions of the binary inputs are defined by the user, applying the graphic equation editor (*Logic Editor*). Parts written in **bold** are seen on the left side function block in the Logic editor.

Table 2-2 The binary input signal of the underfrequency protection function

BINARY OUTPUT SIGNAL	EXPLANATION
TUF81_ Blk _GrO_	Blocking input of the function

2.1.34.2.2.4. Binary output signals (graphed input statuses)

These signals can be used in EuroCAP to assign to LED, user LCD object etc. Parts written in **bold** are seen on the right side of the function block in the *Logic Editor*.

Table 2-3 The binary output signals of the underfrequency protection function

BINARY OUTPUT SIGNAL	SIGNAL TITLE	EXPLANATION
TUF81_ GenSt _Grl_	General Start	General start signal of the function
TUF81_ GenTr _Grl_	General Trip	General trip command of the function

2.1.34.2.2.5. Online data

Visible values on the *online data* page.

Table 2-4 Online displayed data of the underfrequency protection function

SIGNAL TITLE	DIMENSION	EXPLANATION
General Start	-	General start signal of the function
General Trip	-	General trip command of the function

2.1.34.2.2.6. Events

The following events are generated in the event list, as well as sent to the SCADA according to the configuration.

Table 2-5 Generated events of the underfrequency protection function

EVENT	VALUE	EXPLANATION
General Start	off, on	General start of the function
General Trip	off, on	General trip command of the function

2.1.34.2.3. Technical data

The technical data, except for the min. operate voltage, are based on the function block testing according to the directives of the **IEC 60255-181:2019** standard.

Table 2-6 Technical data of the underfrequency protection function

FUNCTION	VALUE	ACCURACY
Operate range	40 - 60 Hz (50 Hz system) 50 - 70 Hz (60 Hz system)	± 3 mHz (20 mHz*)
Effective range	45 - 55 Hz (50 Hz) 55 - 65 Hz (60 Hz)	± 3 mHz (10 mHz*)
Min. operate time	93 ms (50 Hz) 73 ms (60 Hz)	± 32 ms ± 27 ms
Time delay	140 – 60000 ms <140 ms (50 Hz) <140 ms (60 Hz)	± 4 ms ± 32 ms ± 27 ms
Reset frequency	[Start freq.] + 101 mHz	± 1 mHz
Reset time	98 ms (50 Hz) 85 ms (60 Hz)	± 6 ms
Reset ratio for U limit	0.8	

*with the harmonic content according to the standard

2.1.34.2.4. Notes for testing

Normally in the EuroProt+ devices the trip contacts are assigned to the Trip Logic function block, and not to the protection function blocks. Because of this, the testing personnel must make sure that the Trip Logic is switched on ('Operation' parameter is set to other than 'Off') before starting the tests, otherwise there will be no physical trip on the relay.

Note that the time delay parameter incorporates the algorithm time as well, so the time delay *does not mean the time difference between the appearance of the start and trip signals* of the function. In other words: it is not the delay between the detection of the fault and the trip that follows it. This should be taken into consideration when checking the disturbance records.

Instead the time delay parameter defines the elapsed time from the appearance of the faulty state to the trip. Because of this, while testing, the delay measurement should start *from the moment of the fault injection* until the trip signal.

The source voltage for frequency measurement is defined by the voltage input of the functionblock. This can be checked in the functionblock properties in EuroCAP.

Before the fault injection at least 1 second pre-fault should be simulated with nominal frequency and voltage.

Based on IEC 60255-181 standard recommendations, the operation time shall be measured with a frequency of 0.5Hz lower than the setting value for Start frequency.

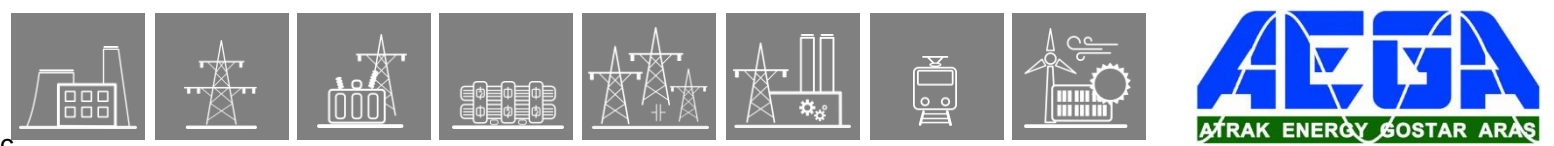

2.1.35. Rate of change of frequency protection function

2.1.35.1. Application

The deviation of the frequency from the rated system frequency indicates unbalance between the generated power and the load demand. If the available generation is large compared to the consumption by the load connected to the power system, then the system frequency is above the rated value, and if it is small, the frequency is below the rated value. If the unbalance is large, then the frequency changes rapidly. The rate of change of frequency protection function is usually applied to reset the balance between generation and consumption to control the system frequency.

Another possible application is the detection of unintended island operation of distributed generation and some consumers. In the island, there is low probability that the power generated is the same as consumption; accordingly, the detection of a high rate of change of frequency can be one of the indications of island operation.

2.1.35.1.1. Mode of operation

Depending on the hardware-software configuration, the frequency measurement is usually based on channel No. 1 (line voltage) and channel No. 4 (busbar voltage) of any voltage input module.

The accurate frequency measurement is performed by measuring the time period between two rising edges and also between two falling edges at zero crossing of a voltage signal. The frequency value is calculated by the average of these two values. At each zero crossing the average value (and the frequency) is recalculated.

For the acceptance of the measured frequency, at least four subsequent valid measurements are needed. Similarly, four invalid measurements are needed to reset the measured frequency from the last valid value to zero.

Other basic criterion is that the evaluated voltage should be above 10% of the rated voltage value.

The rate of change of frequency protection function generates a start signal if the df/dt value is above the setting value. The rate of change of frequency is calculated as the difference of the frequency at the present sampling and at 5 periods earlier; the df/dt comparator has a built-in delay of 100 ms to filter out unwanted operations.

2.1.35.2. Rate of change of frequency protection function overview

The graphic appearance of the function block of the rate of change of frequency protection function is shown below. The block shows all binary input and output status signals which are applicable in the graphic equation editor.

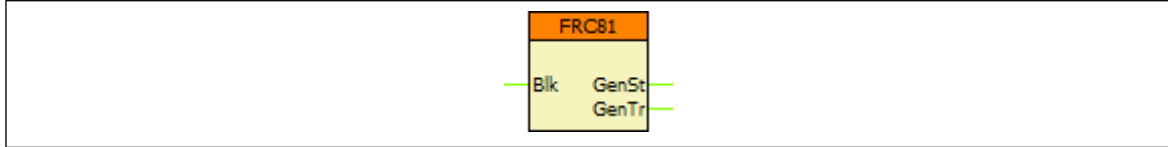

Figure 2-1 Graphic appearance of the function block of the rate of change of frequency protection function

2.1.35.2.1. Settings

2.1.35.2.1.1. Parameters

The available parameters are listed below in order of their appearance in the *parameters* menu. If the setting range of a parameter should be extended, contact Protecta Support.

Table 2-1 Parameters of the rate of change of frequency protection function

TITLE	DIM	RANGE	STEP	DEFAULT	EXPLANATION
Operation	-	Off, On	-	Off	Enabling the function
Start Signal Only	-	FALSE, TRUE	-	FALSE	Enabling start signal only
Start df/dt	Hz/sec	-5.00 – 5.00	0.01	0.50	Setting value of the comparison
Time Delay	msec	200* – 10000	1	200	Time delay (including the algorithm time, see Chapter 2.4 for more explanation)

**the minimum operate time is lower than the settable minimum delay, however below this value the timing is less accurate, see Chapter 2.3 for details*

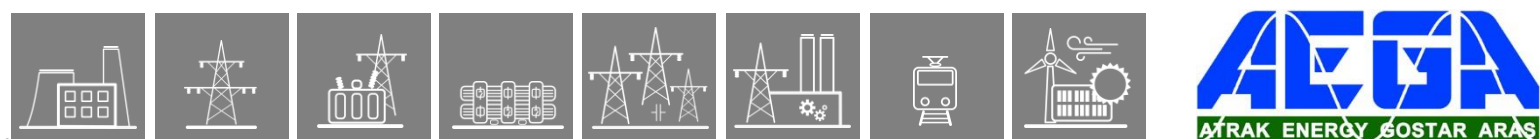

2.1.35.2.2. Function I/O

This section describes briefly the analogue and digital inputs and outputs of the function block.

2.1.35.2.2.1. Analogue inputs

The function uses the sampled values of a voltage input or a calculated line-to-line voltage. This is defined in the configuration.

2.1.35.2.2.2. Binary input signals (graphed output statuses)

The conditions of the binary inputs are defined by the user, applying the graphic equation editor (*Logic Editor*). Parts written in **bold** are seen on the left side function block in the *Logic editor*.

Table 2-2 The binary input signal of the rate of change of frequency protection function

BINARY OUTPUT SIGNAL	EXPLANATION
FRC81_ Blk _GrO_	Blocking input of the function

2.1.35.2.2.3. Binary output signals (graphed input statuses)

These signals can be used in EuroCAP to assign to LED, user LCD object etc. Parts written in **bold** are seen on the right side of the function block in the *Logic Editor*.

Table 2-3 The binary output signals of the rate of change of frequency protection function

BINARY OUTPUT SIGNAL	SIGNAL TITLE	EXPLANATION
FRC81_ GenSt _Grl_	General Start	General start signal of the function
FRC81_ GenTr _Grl_	General Trip	General trip command of the function

2.1.35.2.2.4. Online data

Visible values on the *online data* page.

Table 2-4 Online displayed data of the rate of change of frequency protection function

SIGNAL TITLE	DIMENSION	EXPLANATION
General Start	-	General start signal of the function
General Trip	-	General trip command of the function

2.1.35.2.2.5. Events

The following events are generated in the event list, as well as sent to the SCADA according to the configuration.

Table 2-5 Generated events of the rate of change of frequency protection function

EVENT	VALUE	EXPLANATION
General Start	off, on	General start of the function
General Trip	off, on	General trip command of the function

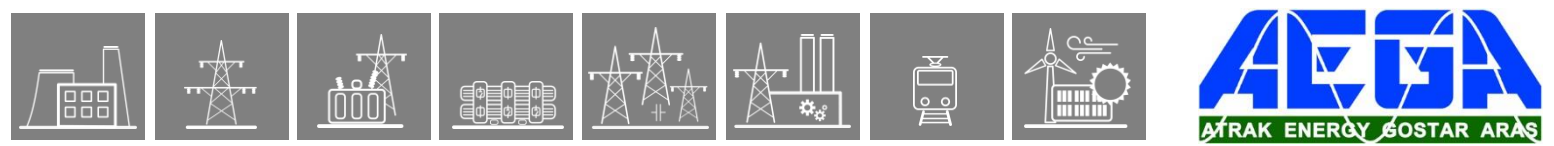

The **software modules** of the differential protection function:

Vector group

This module compensates the phase shift and turn's ratio of the transformer. The results of this calculation are the "sampled values" of the phase-shifted phase currents for all three (two) sides of the transformer and those of the three differential currents.

Diff base harm.

This module calculates the basic Fourier components of the three differential currents. These results are needed for the high-speed differential current decision and for the second and fifth harmonic restraint calculation.

Diff 2. harm.

This module calculates the second harmonic Fourier components of the three differential currents. These results are needed for the second harmonic restraint decision.

Diff 5. harm.

This module calculates the fifth harmonic Fourier components of the three differential currents. These results are needed for the fifth harmonic restraint decision.

2. harm. restraint

The differential current can be high in case of transformer energizing, due to the current distortion caused by the transformer iron core asymmetric saturation. In this case the second harmonic content of the differential current is applied in this module to disable the operation of the differential protection function.

The differential current can be high in case of external faults, due to the current distortion caused by saturated CT on the faulty side. Additional usage of the second harmonic restraint in these cases can help to disable the operation of the differential protection function.

The result of this calculation is needed for the decision logic.

5. harm. restraint

The differential current can be high in case of over-excitation of the transformer, due to the current distortion caused by the transformer iron core symmetric saturation. In this case the fifth harmonic content of the differential current is applied in this module to disable the operation of the differential protection function. The result of this calculation is needed for the decision logic.

Current magnitude

This module calculates the magnitude of the phase-shifted phase currents and that of the differential currents. The result of this calculation is needed for the differential characteristic evaluation.

Differential characteristics

This module performs the necessary calculations for the evaluation of the "percentage differential characteristics". The result of this calculation is needed for the decision logic.

Decision logic

The decision logic module decides if the differential current of the individual phases is above the characteristic curve of the differential protection function. This curve is the function of the restraint current, which is calculated based on the magnitude of the phase-shifted phase currents. This module calculates the second and fifth harmonic ratio of the differential current, relative to the basic harmonic content. The result can restrain the operation of the differential protection function. The high-speed overcurrent protection function based on the differential currents is performed in this module too.

The following description explains the details of the individual components.

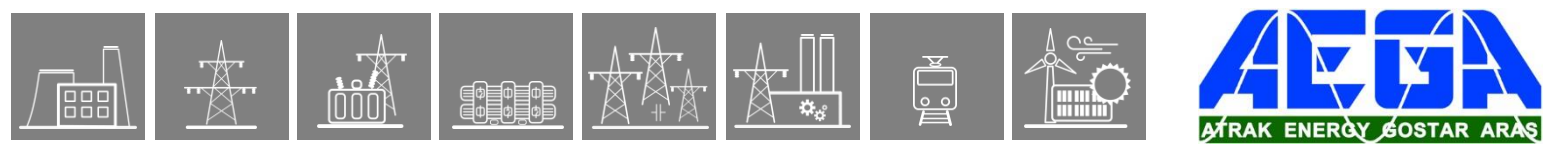

2.1.36.1.2. Turn's ratio matching and vector shift compensation (Vector group)

The three-phase power transformers transform the primary current to the secondary side according to the turn's ratio and the vector group of the transformers. The Y (star) D (delta) or Z (zig-zag) connection of the three phase coils on the primary and on the secondary side causes vector shift of the currents. The conventional electromechanical or static electronic devices of the differential protection compensate the vector shift with appropriate connection of the current transformer coils. The numerical differential protection function applies matrix transformation to the directly measured currents of one side of the transformer to match them with the currents of the other side(s).

In the transformer differential protection of Protecta the software module „Vector_group” calculates the matrix transformation and the turn's ratio matching. Here the target of the matrix transformation is the delta (D) side.

2.1.36.1.2.1. Turn's ratio matching

In the transformer, the magnitude of the current is transformed according to the turn's ratio (and the vector group) of the transformers. In practical terms this transformation is expressed as the voltage ratio(s). For the calculation, the rated voltages of the transformation is to be declared: “Un Primary”, “Un Secondary” and in case of transformer with three voltage levels also “Un Tertiary”.

The differential protection function needs also a reference current. The specific points of the differential characteristic are expressed as percent of this reference current. This value is calculated internally, based on the rated power of the transformer. It is usual that for transformers with three voltage levels – where the rated power for all three sides can be different – the value for the primary side is to be set as a parameter. NOTE: when selecting other values, the scaling of the differential characteristic also changes.

The summary of the parameters needed for turn's ratio matching are summarized in [Table 1-1](#).

Floating point parameters

Table 1-1 The floating-point parameters for the turn's ratio compensation

PARAMETER NAME	TITLE	DIM.	MIN	MAX	DEFAULT
Rated power (primary side) of the transformer					
DIF87_Sn_FPar_	Sn	MVA	1.00	1000.00	125.00
Rated voltages Un1, Un2 (and Un3 if tertiary side also available)					
DIF87_UTRPri_FPar_	Un Primary	kV	1.00	1000.00	132.00
DIF87_UTRSec_FPar_	Un Secondary	kV	1.00	1000.00	22.00
DIF87_UTRTer_FPar_	Un Tertiary	kV	1.00	1000.00	11.50

Based on these parameters, the reference current for the high voltage primary side of the transformer is calculated with the well-known formula:

$$I_{reference_1} = \frac{S_n}{\sqrt{3} U_{n1}}$$

Where:

- $I_{reference_1}$ is the reference current for the high voltage primary side of the transformer,
- S_n is the rated power of the primary side of the transformer,
- U_{n1} is the rated voltage of the primary side of the transformer.

This reference current can be transformed to the secondary or to the tertiary sides of the transformer for the reference values of other sides. For the relay, these reference values are transmitted by the current transformers, according to the CT turn's ratios. This information is set in the CT modules of the device as parameter values.

Table 1-2 Vector shift compensation matrices

Matrix ID	Matrix
U0	$\begin{bmatrix} 1 & 0 & 0 \\ 0 & 1 & 0 \\ 0 & 0 & 1 \end{bmatrix}$
U6	$\begin{bmatrix} -1 & 0 & 0 \\ 0 & -1 & 0 \\ 0 & 0 & -1 \end{bmatrix}$
P11	$\frac{1}{\sqrt{3}} * \begin{bmatrix} 1 & -1 & 0 \\ 0 & 1 & -1 \\ -1 & 0 & 1 \end{bmatrix}$
P5	$\frac{1}{\sqrt{3}} * \begin{bmatrix} -1 & 1 & 0 \\ 0 & -1 & 1 \\ 1 & 0 & -1 \end{bmatrix}$
P1	$\frac{1}{\sqrt{3}} * \begin{bmatrix} 1 & 0 & -1 \\ -1 & 1 & 0 \\ 0 & -1 & 1 \end{bmatrix}$
P7	$\frac{1}{\sqrt{3}} * \begin{bmatrix} -1 & 0 & 1 \\ 1 & -1 & 0 \\ 0 & 1 & -1 \end{bmatrix}$
Z0	$\frac{1}{3} * \begin{bmatrix} 2 & -1 & -1 \\ -1 & 2 & -1 \\ -1 & -1 & 2 \end{bmatrix}$
Z6	$\frac{1}{3} * \begin{bmatrix} -2 & 1 & 1 \\ 1 & -2 & 1 \\ 1 & 1 & -2 \end{bmatrix}$
Z4	$\frac{1}{3} * \begin{bmatrix} -1 & 2 & -1 \\ -1 & -1 & 2 \\ 2 & -1 & -1 \end{bmatrix}$
Z10	$\frac{1}{3} * \begin{bmatrix} 1 & -2 & 1 \\ 1 & 1 & -2 \\ -2 & 1 & -1 \end{bmatrix}$
Z8	$\frac{1}{3} * \begin{bmatrix} -1 & -1 & 2 \\ 2 & -1 & -1 \\ -1 & 2 & -1 \end{bmatrix}$
Z2	$\frac{1}{3} * \begin{bmatrix} 1 & 1 & -2 \\ -2 & 1 & 1 \\ 1 & -2 & 1 \end{bmatrix}$
U4	$\begin{bmatrix} 0 & 1 & 0 \\ 0 & 0 & 1 \\ 1 & 0 & 0 \end{bmatrix}$
U10	$\begin{bmatrix} 0 & -1 & 0 \\ 0 & 0 & -1 \\ -1 & 0 & 0 \end{bmatrix}$

Application of the matrix transformation for two winding transformers

The primary winding of a power transformer can be “Y” or “D” (Delta) connected.

If the primary is “Y” connected then the secondary can be configured to “y”, “d” or “z”. The possible combinations are shown in [Table 1-3](#).



2.1.36.1.2.5. Operation with the zero-sequence current in case of phase-to-ground fault on the delta side

On the secondary side of a high voltage/medium voltage transformer which is connected in delta on the medium voltage side, an additional neutral grounding transformer is applied. Between the neutral point of this grounding transformer and the ground, either a grounding resistor is connected to limit the single phase to ground fault currents below 100 A (in some cases 200 A), or here a Petersen coil is applied which limits the single phase fault currents to a small value of some Amps.

In these cases, there are two locations for the currents transformers on the delta side to supply the differential protection. In one case the neutral grounding transformer is located inside the protected zone of the differential protection (*in Figure 3-7 and Figure 3-8 of the Appendix* it is the location "Z"), in the other case the neutral grounding transformer is outside the protected zone (*in Figure 3-7 and Figure 3-8 of the Appendix* this is the application of the current transformers on location „Y”).

If the neutral grounding transformer is in the protected zone, then the current distribution depends on the location of the supplying generator, as it is shown *in Figure 3-7 and Figure 3-8 of the Appendix*. In these cases, for correct operation of the differential protection (if the operating characteristic lines are set to be sensitive) the subtraction of the zero sequence current is needed. This additional transformation „replaces” the measuring location to the point („Y”), where no zero sequence current can flow, so these transformed currents do not include the zero sequence current of the neutral grounding transformer.

2.1.36.1.2.6. The principal scheme of the vector group compensation

Figure 1-2 shows the principal scheme of the vector shift compensation.

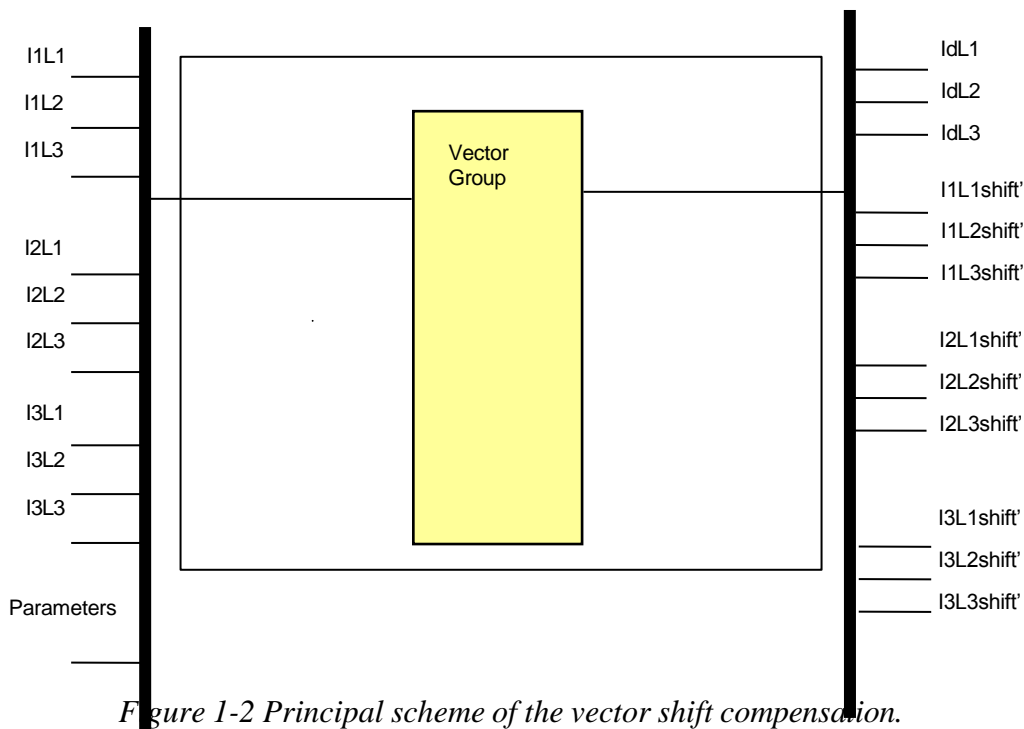

Figure 1-2 Principal scheme of the vector shift compensation.

The **inputs** are the sampled values of:

- The three phase currents of the primary side (I1L1, I1L2, I1L3)
- The three phase currents of the secondary side (I2L1, I2L2, I2L3)
- The three phase currents of the tertiary side (I3L1, I3L2, I3L3 in DIF87T3 version only)
- Parameters for vector shift and turn's ratio compensation.

Enumerated parameters for the vector shift compensation:

Table 1-7 Enumerated parameters for the vector shift compensation

Parameter name	Title	Selection range	Default
Parameter to select connection group of the transformer coils in primary-secondary relation:			
DIF87_VGrSec_EPar_	Pri-Sec VGroup*	Dy1,Dy5,Dy7,Dy11,Dd0,Dd6,Dz0,Dz2,Dz4,Dz6,Dz8,Dz10,Yy0,Yy6,Yd1,Yd5,Yd7,Yd11,Yz1,Yz5,Yz7,Yz11	Dd0
Parameter to select connection group of the transformer coils in primary-tertiary relation:			
DIF87_VGrTer_EPar_	Pri-Ter VGroup*	Dy1,Dy5,Dy7,Dy11,Dd0,Dd6,Dz0,Dz2,Dz4,Dz6,Dz8,Dz10,Yy0,Yy6,Yd1,Yd5,Yd7,Yd11,Yz1,Yz5,Yz7,Yz11	Dd0

* If the connection of the primary winding in primary-secondary and primary tertiary relation is selected in contradiction then the protection function is automatically disabled, and the function generates a warning signal.

Boolean parameter for the vector shift compensation:

Table 1-8 The Boolean parameter for the vector shift compensation

Parameter name	Title	Default	Explanation
DIF87_0Seq_BPar_	Zero Seq Elimination	True	See Chapter 1.1.5

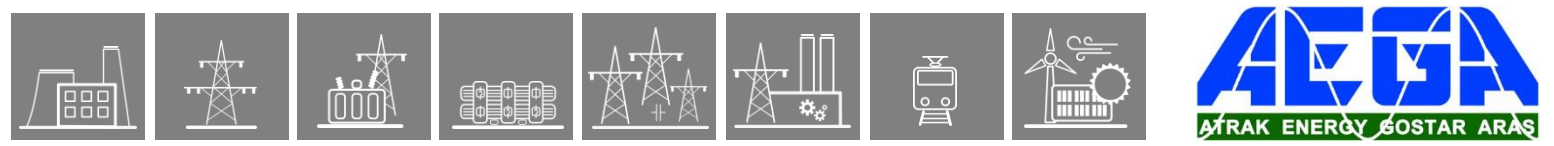

The **outputs** are the “sampled values” of the phase-shifted currents:

- The differential currents after phase-shift $\left[\begin{array}{c} IdL1 \\ IdL2 \\ IdL3 \end{array} \right]$
- The primary currents after phase-shift $\left[\begin{array}{c} I1L1shift \\ I1L2shift \\ I1L3shift \end{array} \right]$
- The secondary currents after phase-shift $\left[\begin{array}{c} I2L1shift \\ I2L2shift \\ I2L3shift \end{array} \right]$
- The tertiary currents after phase-shift (in DIF87T3 version only) $\left[\begin{array}{c} I3L1shift \\ I3L2shift \\ I3L3shift \end{array} \right]$



2.1.36.1.3. Harmonic analysis of the differential currents (Diff basic harm.), (Diff 2. harm.), (Diff 5. harm.)

2.1.36.1.3.1. The principle of calculation

The differential current can be high in case of transformer energizing, due to the current distortion caused by the transformer iron core asymmetric saturation. In this case the second harmonic content of the differential current is applied to disable the operation of the differential protection function.

The differential current can also be high in case of external faults, due to the current distortion caused by saturated CT on the faulty side. Additional usage of the second harmonic restraint in these cases disables the operation of the differential protection function.

The differential current can be high in case of over-excitation of the transformer, due to the current distortion caused by the transformer iron core symmetric saturation. In this case the fifth harmonic content of the differential current is applied to disable the operation of the differential protection function.

The harmonic analysis block of modules consists of three individual software modules.

Diff base harm.

This module calculates the basic Fourier components of the three differential currents. These results are needed for the high-speed differential current decision and for the second and fifth harmonic restraint calculation.

Diff 2. harm.

This module calculates the second harmonic Fourier components of the three differential currents. These results are needed for the second harmonic restraint decision.

Diff 5. harm.

This module calculates the fifth harmonic Fourier components of the three differential currents. These results are needed for the fifth harmonic restraint decision.

2.1.36.1.3.2. The principal scheme of the harmonic analysis

Figure 1-3 shows the structure of the harmonic analysis.

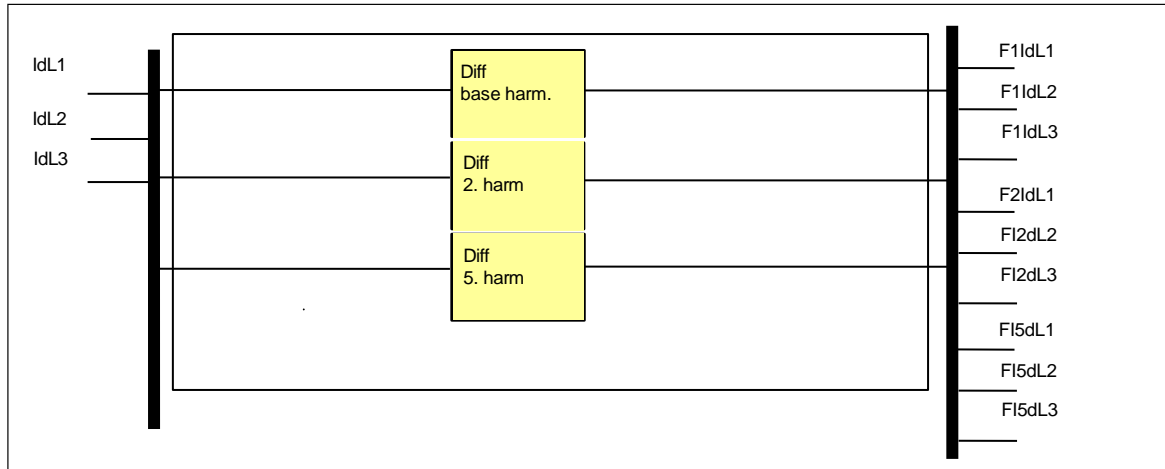

Figure 1-3 Principal scheme of the harmonic analysis.

The **inputs** are the “sampled values” of the differential currents, based on the phase-shifted currents:

- The differential currents after phase-shift
- $$\begin{bmatrix} IdL1 \\ IdL2 \\ IdL3 \end{bmatrix}$$

The **outputs** are the basic, the second and the fifth harmonic Fourier components of the differential currents (also as p.u. of the reference current):

- The basic harmonic Fourier components of the differential currents
- $$\begin{bmatrix} F1dL1 \\ F1dL2 \\ F1dL3 \end{bmatrix}$$
- The second harmonic Fourier components of the differential currents
- $$\begin{bmatrix} F2dL1 \\ F2dL2 \\ F2dL3 \end{bmatrix}$$
- The fifth harmonic Fourier components of the differential currents
- $$\begin{bmatrix} F5dL1 \\ F5dL2 \\ F5dL3 \end{bmatrix}$$

These values are processed by the software modules 2. harmonic restraint and 5. harmonic restraint

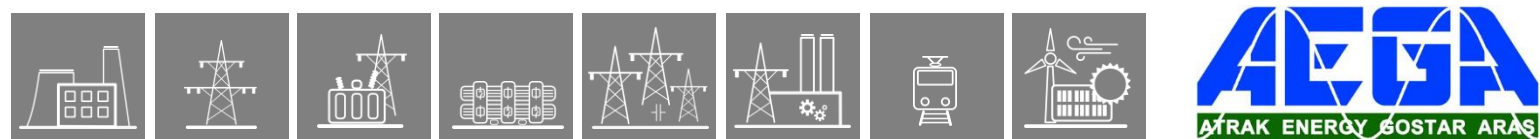

2.1.36.1.4. The harmonic restraint decision (2. harmonic restraint) and (5. harmonic restraint)

2.1.36.1.4.1. The principle of the restraint decision

The differential current can be high in case of transformer energizing, due to the current distortion caused by the transformer iron core asymmetric saturation. In this case the second harmonic content of the differential current is applied to disable the operation of the differential protection function.

The differential current can be high in case of external faults, due to the current distortion caused by saturated CT on the faulty side. Additional usage of the second harmonic restraint in these cases can help to disable the operation of the differential protection function.

The differential current can be high in case of over-excitation of the transformer as well, due to the current distortion caused by the transformer iron core symmetric saturation. In this case the fifth harmonic content of the differential current is applied to disable the operation of the differential protection function.

The harmonic analysis block of modules consists of two sub-blocks, one for the second harmonic decision and one for the fifth harmonic decision. Each sub-block includes three individual software modules for the phases.

The software modules evaluate the harmonic content relative to the basic harmonic component of the differential currents, and compare the result with the parameter values, set for the second and fifth harmonic. If the content is high, then the assigned status signal is set to “true” value. If the duration of the active status is at least 25 ms (or 20.83 ms on a 60 Hz system), then resetting of the status signal is delayed by additional 15 ms (12.5 ms on a 60 Hz system).

Depending on the dedicated Boolean parameter setting “Cross Blocking”, there are two modes of operation:

- If the “Cross Blocking” parameter is FALSE (not checked) then the three “measuring elements” operate individually. The internal output signal of the “measuring element” is blocked only if the own differential current contains harmonics (second and/or fifth) above the setting level, indicating inrush current or over-excitation. Other measuring element may generate trip requirement.
- If the “Cross Blocking” parameter is TRUE (checked) then the three blocking any of the “measuring elements” by harmonics (second and/or fifth) above the setting level blocks also the internal output signal of all three “measuring elements”. The function does not generate trip requirement.

The duration of the cross blocking is set by a dedicated parameter “Cross Blocking Limit”. This is the maximum duration of cross-blocking; after timeout, the cross-blocking resets even if there are high values of harmonics in another “measuring element(s)”. Note that the “measuring element(s)” with high values of harmonics will keep on self-blocking.

2.1.36.1.4.2. The principal scheme of the harmonic restraint decision

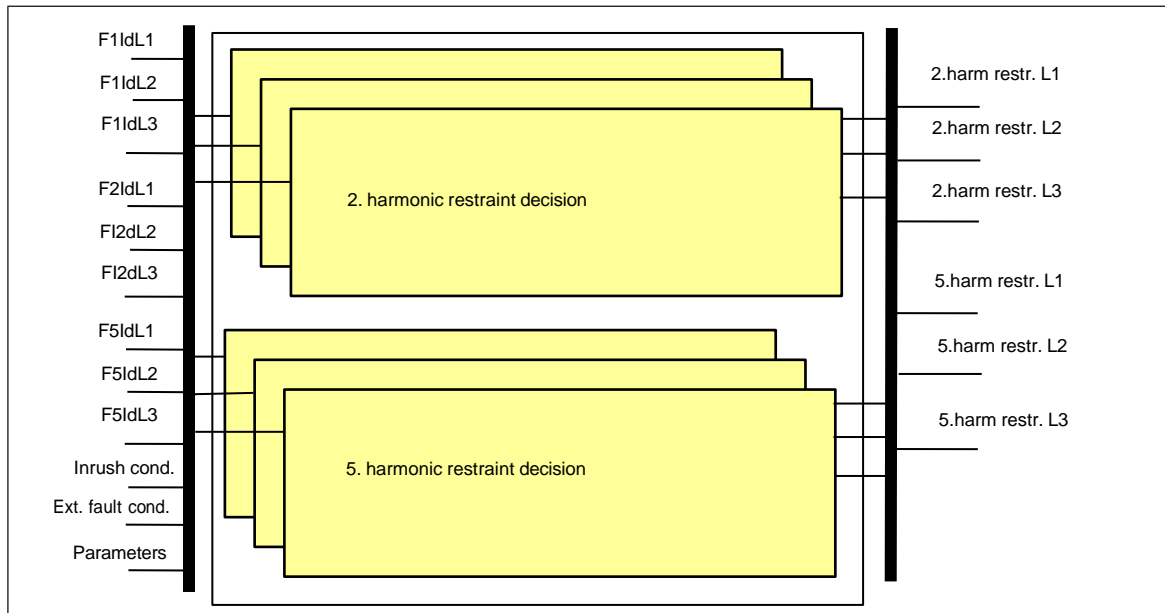

Figure 1-4 Principal scheme of the harmonic restraint decision

The **inputs** are the following:

- The basic harmonic Fourier components of the differential currents

$$\begin{bmatrix} F1dL1 \\ F1dL2 \\ F1dL3 \end{bmatrix}$$

- The second harmonic Fourier components of the differential currents

$$\begin{bmatrix} F2IdL1 \\ F2IdL2 \\ F2IdL3 \end{bmatrix}$$

- The fifth harmonic Fourier components of the differential currents

$$\begin{bmatrix} F5IdL1 \\ F5IdL2 \\ F5IdL3 \end{bmatrix}$$

- Inrush condition detection for 2nd harmonic decision
- External fault condition detection for 2nd harmonic decision
- Parameter settings for harmonic detection

The outputs of the modules are the status signals for each phase and for second and fifth harmonics separately, indicating the restraint status caused by high harmonic contents.

2.1.36.1.4.2.1. Inrush condition for 2nd harmonic block

For blocking the differential protection function during inrush, the second harmonic restraint is evaluated if the transformer is detected to be either off or recently switched on. The **Inrush condition** signal indicates this state.

The inrush condition deactivates after a *5 seconds delay (or 4.167 seconds on a 60 Hz system)* if the following two conditions are fulfilled:

- any of the phase currents exceed 2%,
- there are no 2nd harmonics detected, see [Figure 1-7](#) and the figure below:

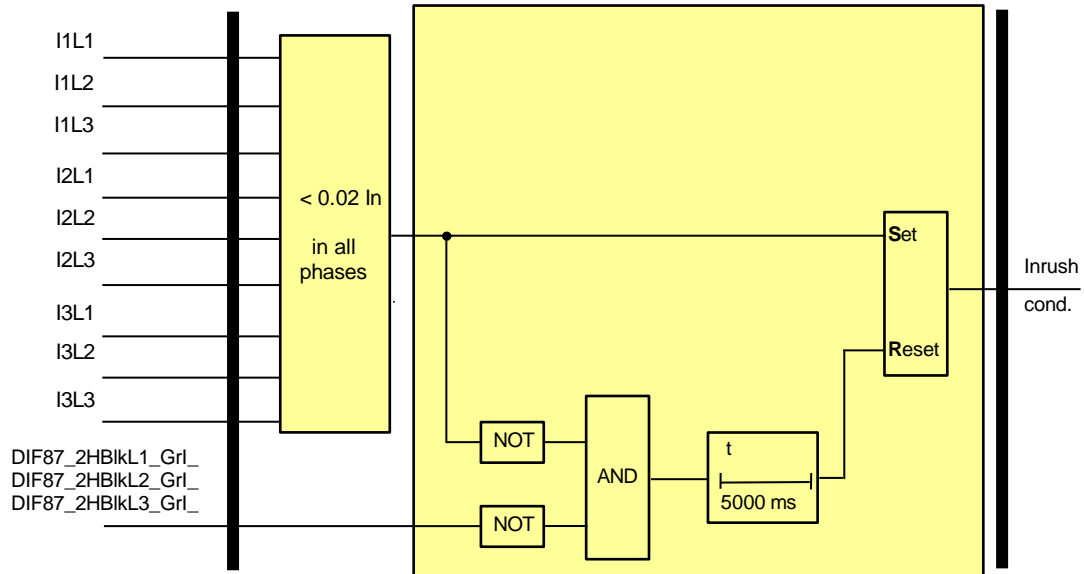

**the value is connected to the cycle time of 50 Hz. For 60 Hz applications it becomes lower: 4166.67 ms*

Figure 1-5 Logic scheme of the inrush condition

2.1.36.1.4.2.2. External fault condition for 2nd harmonic block

The second harmonic restraint is also evaluated for disabling the differential protection function during external faults with CT saturation. The **Ext. fault condition** signal indicates this state. This signal activates when the shifted and compensated currents between the two sides have at least an angle difference of **75 degrees**.

For valid angle measurement, it is required that the involved sides' shifted currents' magnitude is larger than **10%** (of the reference current, which is the transformer rated current).

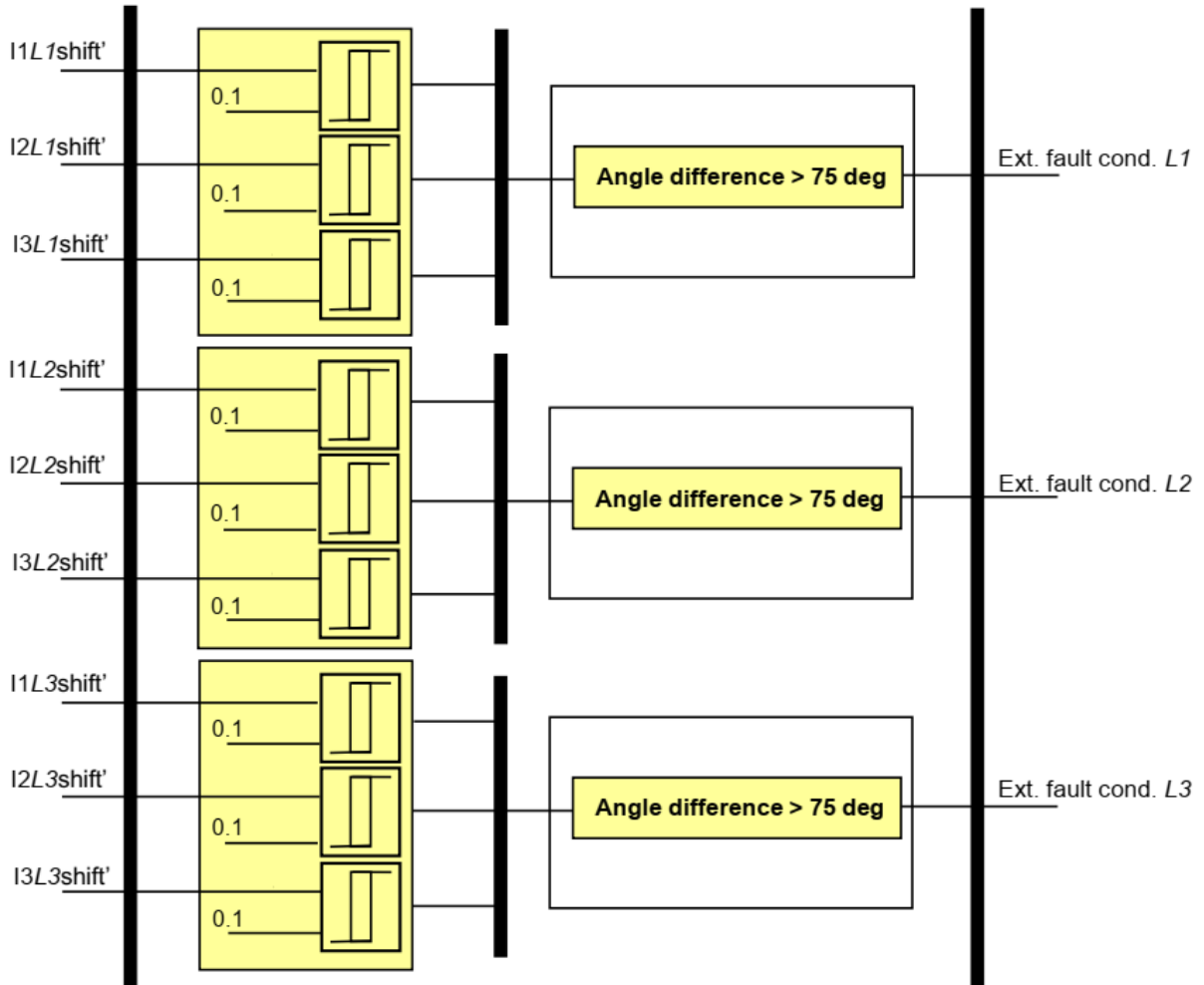
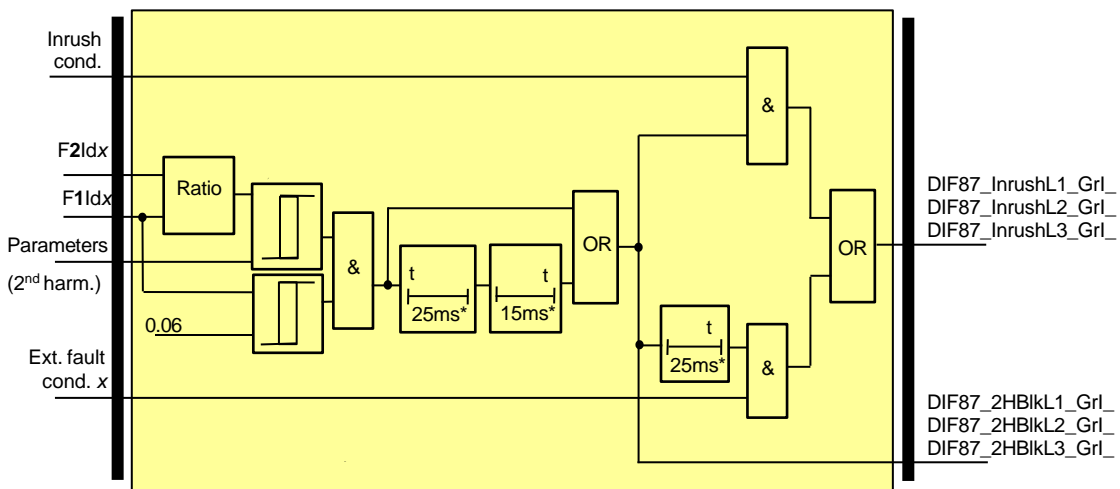

Figure 1-6 Logic scheme of the external fault condition

2.1.36.1.4.2.3. 2nd harmonic blocking scheme

The 2nd harmonic restraint function follows the logic below:



*the values are connected to the cycle time of 50 Hz. For 60 Hz applications these become lower: 20.83 ms and 12.5 ms
 Figure 1-7 Logic scheme of the 2nd harmonic decision based on inrush or external fault

The logic scheme is repeated for the **second** harmonic restraint decision for all three phases ("measuring elements") separately (x=L1, L2, L3).

First the ratio of the harmonic and the base harmonic is calculated, and this ratio is compared to the parameter setting (second and fifth separately). In case of high ratio value, the restraint signal is generated immediately, and at the same time a timer is started. If the 25 ms (or 20.83 ms on a 60 Hz system) delay is over, and during the running time the high ratio was continuous, then a drop-off timer is started, which extends the duration of the restraint signal.

The restraint signal is generated if either the inrush condition or the external fault condition is active.

The decisions of the phases are connected in OR gate to result harmonic restraint status signal: DIF87_Inrush_Gr_ (Inrush). Note that the signal includes both cases where the 2nd harmonics are evaluated.

2.1.36.1.4.2.4. 5th harmonic blocking scheme

The 5th harmonic restraint function follows the logic below:

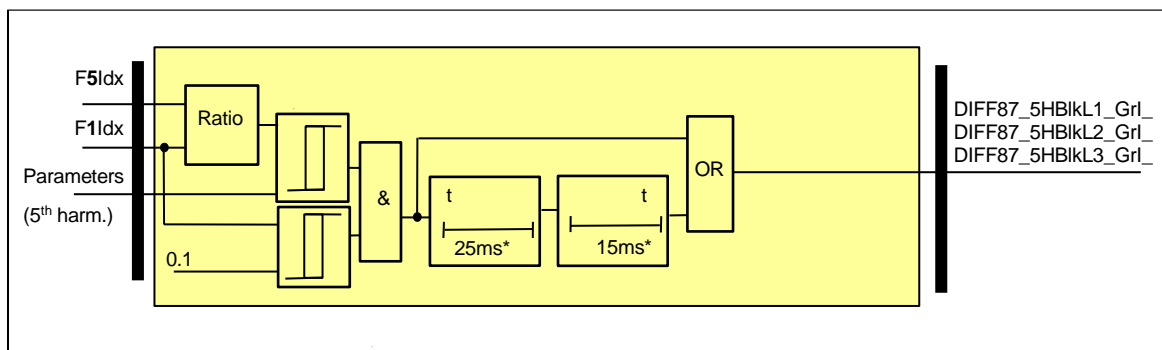

*the values are connected to the cycle time of 50 Hz. For 60 Hz applications these become lower: 20.83 ms and 12.5 ms
 Figure 1-8 Logic scheme of the 5th harmonic restraint decision

The logic for the fifth harmonic restraint decision is like the second harmonic one with the difference that there are no further conditions other than the minimum differential current.

2.1.36.1.5. The current magnitude calculation (Current magnitude)

2.1.36.1.5.1. The principle of the current magnitude calculation

The module, which evaluates the differential characteristics, compares the magnitude of the differential currents and those of the restraint currents. For this calculation the current magnitudes are needed. These magnitudes are calculated in this module.

2.1.36.1.5.2. The principal scheme of the current magnitude calculation

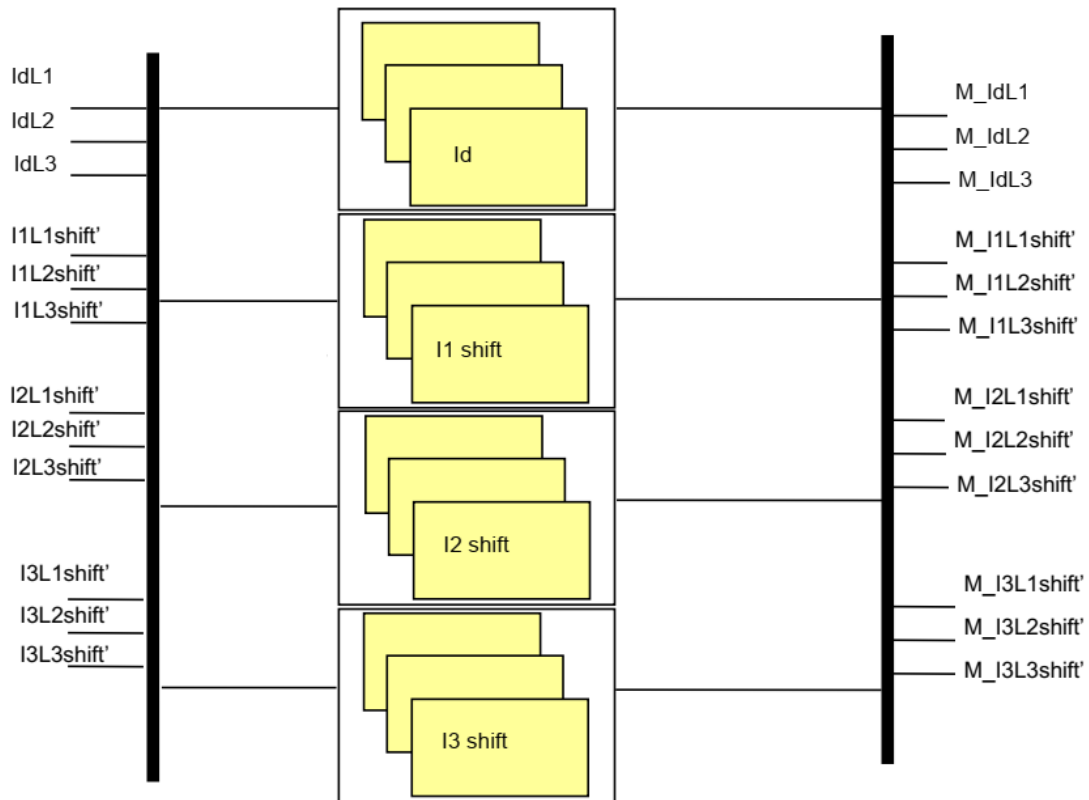
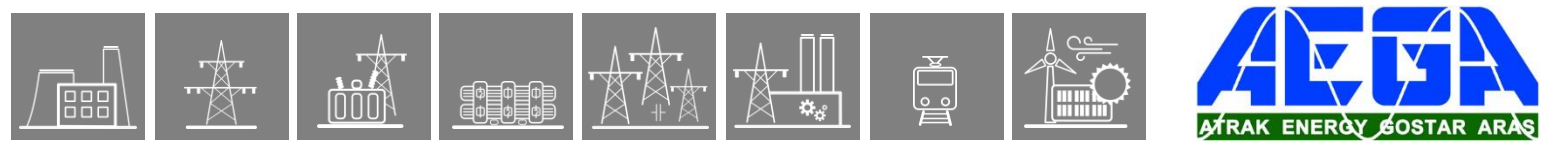

Figure 1-9 Principal scheme of the current magnitude calculation

The **inputs** are the “sampled values” of the phase-shifted currents:

- The differential currents after phase-shift $\begin{bmatrix} IdL1 \\ IdL2 \\ IdL3 \end{bmatrix}$
- The primary currents after phase-shift $\begin{bmatrix} I1L1shift' \\ I1L2shift' \\ I1L3shift' \end{bmatrix}$



- The secondary currents after phase-shift $\begin{bmatrix} I_{2L1shift} \\ I_{2L2shift} \\ I_{2L3shift} \end{bmatrix}$

- The tertiary currents after phase-shift (in DIF87T3 version only) $\begin{bmatrix} I_{3L1shift} \\ I_{3L2shift} \\ I_{3L3shift} \end{bmatrix}$

The **outputs** are the magnitude of the calculated currents

- The magnitudes of the differential currents after phase-shift $\begin{bmatrix} M_IdL1 \\ M_IdL2 \\ M_IdL3 \end{bmatrix}$

- The magnitudes of the primary currents after phase-shift $\begin{bmatrix} M_I1L1shift \\ M_I1L2shift \\ M_I1L3shift \end{bmatrix}$

- The magnitudes of the secondary currents after phase-shift $\begin{bmatrix} M_I2L1shift \\ M_I2L2shift \\ M_I2L3shift \end{bmatrix}$

- The magnitudes of the tertiary currents after phase-shift $\begin{bmatrix} M_I3L1shift \\ M_I3L2shift \\ M_I3L3shift \end{bmatrix}$
(in DIF87T3 version only)

2.1.36.1.6. The evaluation of the differential characteristics (differential characteristics)

2.1.36.1.6.1. The principle of the differential characteristics

This module evaluates the differential characteristics. It compares the magnitude of the differential currents and those of the restraint currents. The restraint (bias) currents are calculated using the following formulas:

$$M_{IbiasL1} = \frac{M_{I1L1shift} + M_{I2L1shift} + M_{I3L1shift}}{2}$$

$$M_{IbiasL2} = \frac{M_{I1L2shift} + M_{I2L2shift} + M_{I3L2shift}}{2}$$

$$M_{IbiasL3} = \frac{M_{I1L3shift} + M_{I2L3shift} + M_{I3L3shift}}{2}$$

Based on these values (denoted generally as “Ibias”) and the values of the differential current magnitudes (denoted generally as “Idiff”) the differential protection characteristics are shown on Figure 1-10.

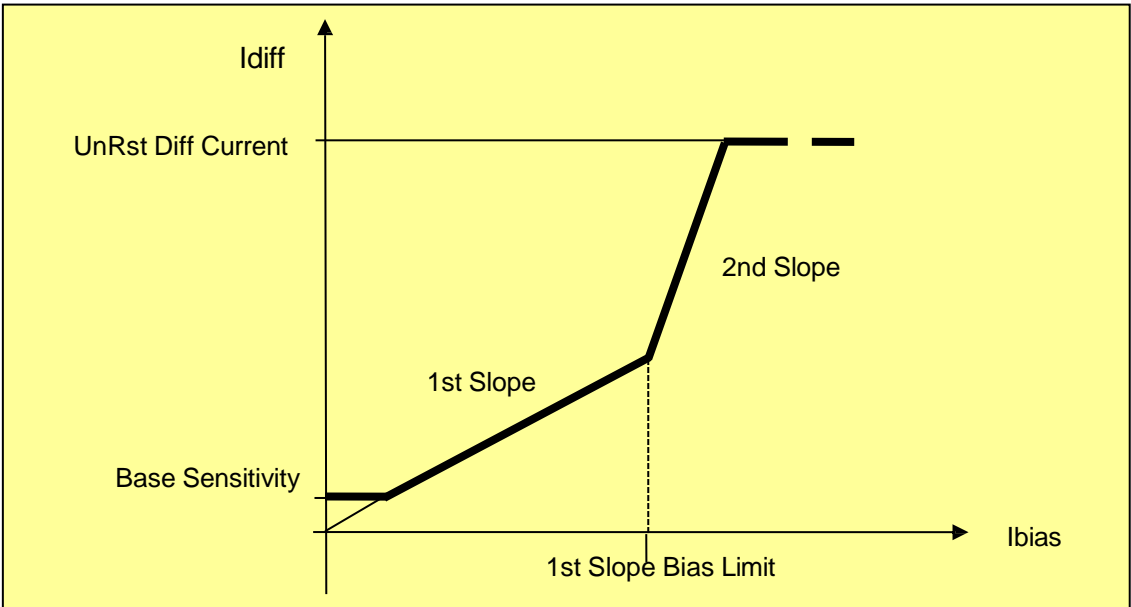

Figure 1-10 The differential protection characteristics

Additionally separate status-signals are set to “true” value if the differential currents in the individual phases are above the limit, set by parameter (see “Unrestrained differential function”).

Table 1-16 The binary output status signals of the unrestrained differential protection characteristics

Binary output signals	Signal title	Explanation
Unrestrained decision		
DIF87_UnRL1St_Grl_i	Start L1 unrestr.	This internal status is true if the differential current in measuring element L1 is above the high current setting
DIF87_UnRL2St_Grl_i	Start L2 unrestr.	This internal status is true if the differential current in measuring element L2 is above the high current setting
DIF87_UnRL3St_Grl_i	Start L3 unrestr.	This internal status is true if the differential current in measuring element L3 is above the high current setting

2.1.36.1.6.3. The principal scheme of the evaluation of differential characteristics

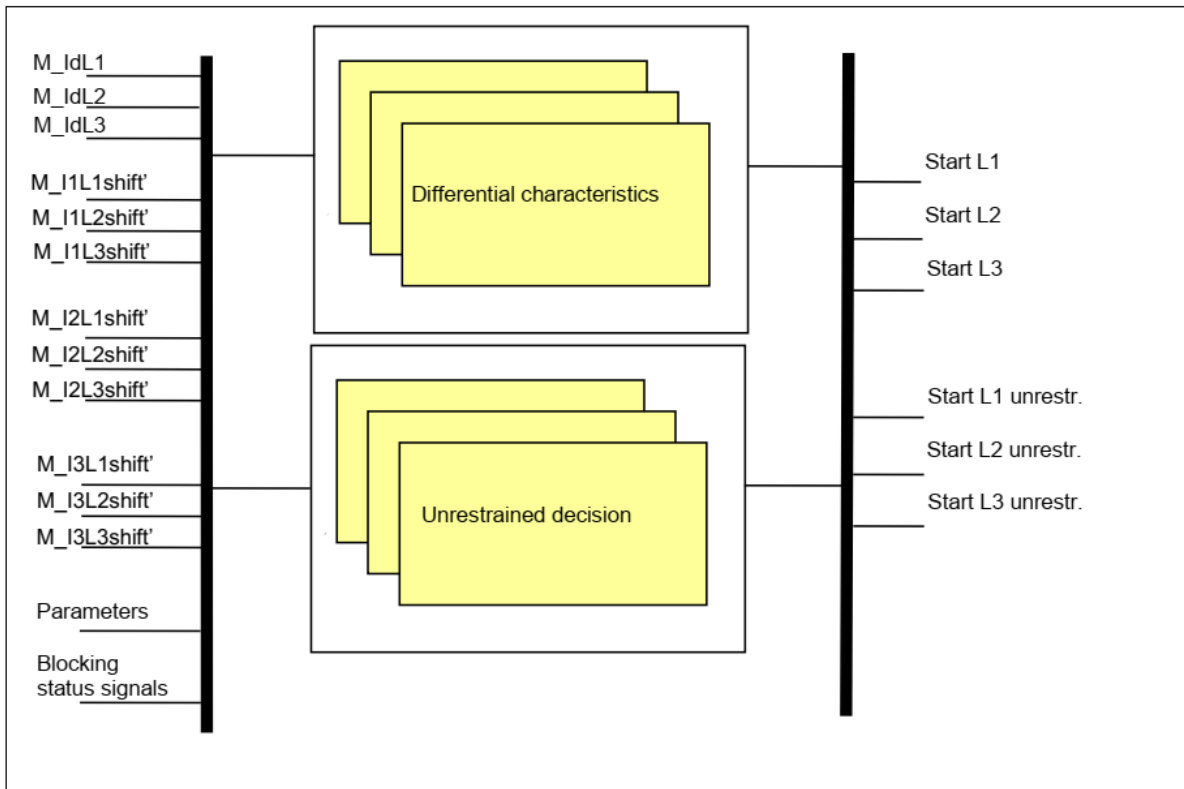

Figure 1-11 The Scheme of evaluation of differential protection characteristics.

The **inputs** are the magnitude of the calculated currents:

- The magnitudes of the differential currents after phase-shift

$$\begin{bmatrix} M_IdL1 \\ M_IdL2 \\ M_IdL3 \end{bmatrix}$$
- The magnitudes of the primary currents after phase-shift

$$\begin{bmatrix} M_I1L1shift' \\ M_I1L2shift' \\ M_I1L3shift' \end{bmatrix}$$

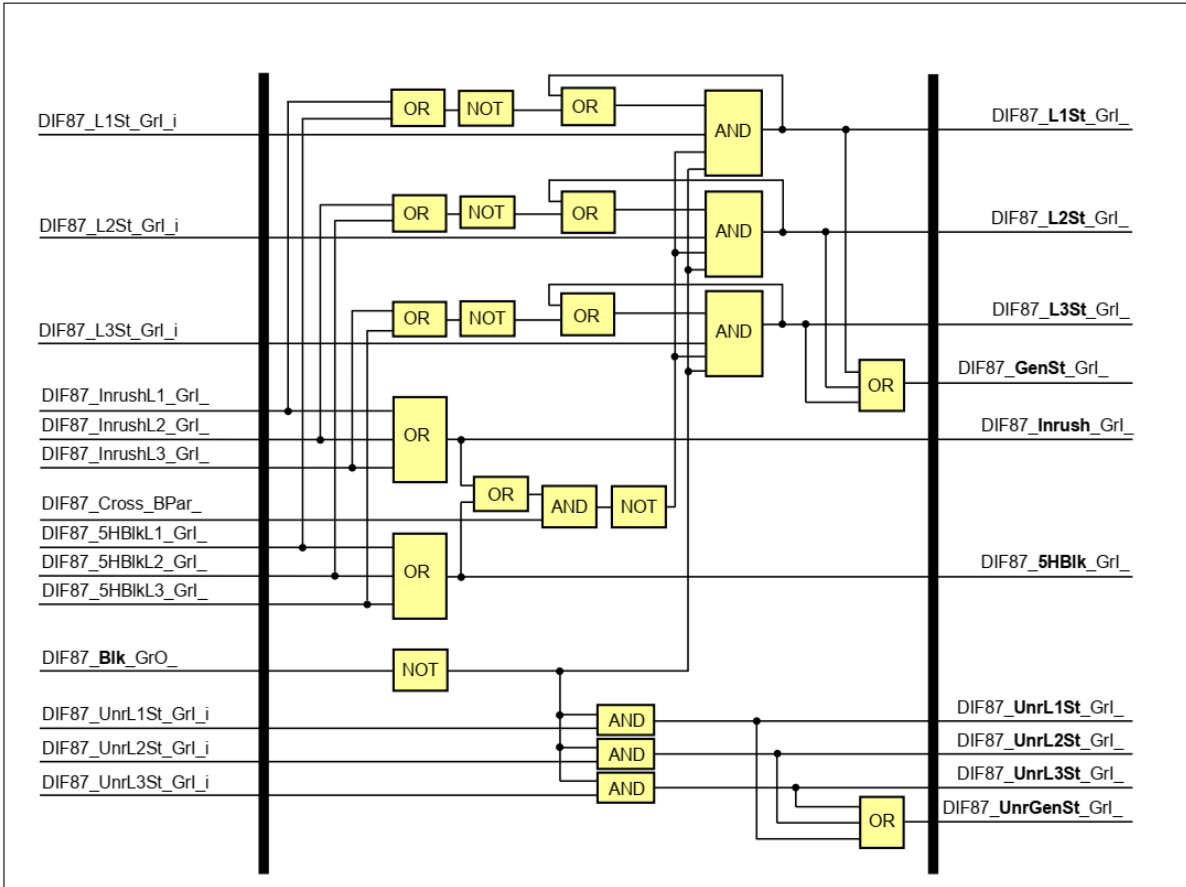

Figure 1-12 The decision logic schema of the differential protection function

2.1.36.1.7.3. Special measures for CT saturation during external faults

Basically, the 2nd slope of the differential characteristic is set to cover the errors caused by saturated CT, however, there are further methods implemented to stabilize the differential protection function even more in case of external faults (while keeping it sensitive for internal ones) with saturated CT. This chapter explains these two special functionalities and their conditions to activate.

- Adaptive characteristics**
 In case of external faults, the differential currents appear a little while after the CT has become saturated. In case of internal faults, these two events happen at the same time. Based on this principle, the differential protection function switches to a less sensitive characteristic if such sign of an external fault is detected.

The condition: the measured Bias current in any phase is above $1.25I_n$ for at least 3 milliseconds while the differential current is less than the set Base Sensitivity. This condition falls off if the Bias current drops below $0.8I_n$.

The characteristic: 1st slope 50% and 2nd slope 200%

- Usage of the 2nd harmonic restraint**
 The second harmonic restraint decision can be enabled if there is at least 75 degrees difference between the measured currents after vector shift compensation (indicating an external fault), see Chapter 1.3.

2.1.36.2. Differential protection function overview

The graphic appearance of the function blocks of the differential protection function for transformers of two or three voltage levels are shown on [Figure 2-1](#). These blocks show all binary input and output status signals, which are applicable in the graphic equation editor.

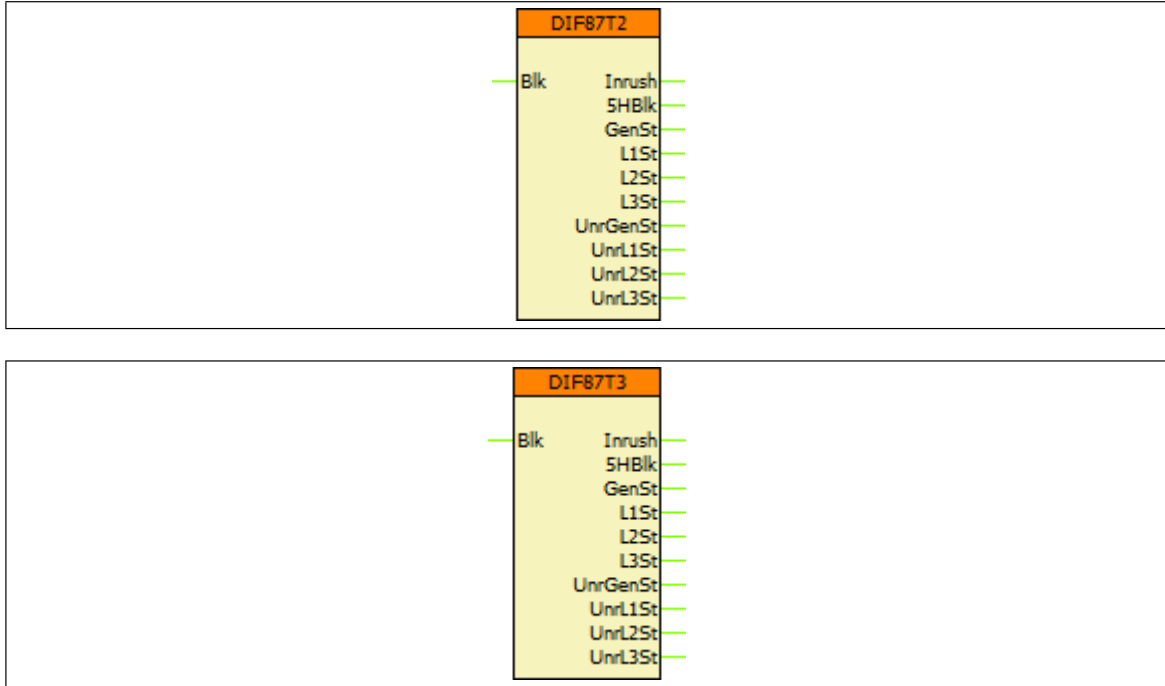
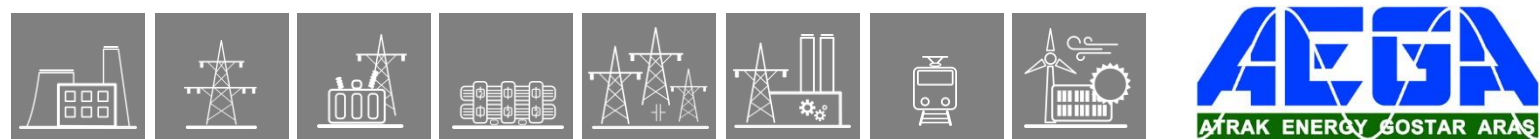

Figure 2-1 Graphic appearance of the function blocks of the differential protection function



2.1.36.2.1. Settings

2.1.36.2.1.1. Parameters

Table 2-1 Parameters of the differential protection function

TITLE	DIM	RANGE	STEP	DEFAULT	EXPLANATION
Operation	-	Off, On	-	Off	Enabling the differential protection function
<i>Parameters related to the protected transformer</i>					
Pri-Sec VGroup	-	Dy1,Dy5,Dy7,Dy11, Dd0,Dd6,Dz0,Dz2, Dz4,Dz6,Dz8,Dz10, Yy0, Yy6, Yd1, Yd5, Yd7, Yd11, Yz1, Yz5, Yz7, Yz11	-	Dd0	Connection group of the transformer coils in primary-secondary relation
Pri-Ter VGroup*	-	Dy1,Dy5,Dy7,Dy11, Dd0,Dd6,Dz0,Dz2, Dz4,Dz6,Dz8,Dz10, Yy0, Yy6, Yd1, Yd5, Yd7, Yd11, Yz1, Yz5, Yz7, Yz11	-	Dd0	Connection group of the transformer coils in primary-tertiary relation
ZeroSeq Elimination	-	FALSE, TRUE	-	FALSE	Check this when a neutral grounding transformer is applied in the protected zone on the delta side (see Chapter 1.1.5)
Sn	MVA	1.00 – 1000.00	0.01	125.00	Rated apparent power of the transformer
Un Primary	kV	1.00 – 1000.00	0.01	132.00	Rated voltage of the transformer primary side
Un Secondary	kV	1.00 – 1000.00	0.01	22.00	Rated voltage of the transformer secondary side
Un Tertiary	kV	1.00 – 1000.00	0.01	11.50	Rated voltage of the transformer tertiary side
<i>Parameters related to the harmonic restraint</i>					
Cross Blocking	-	FALSE, TRUE	-	FALSE	When selected, the harmonic restraint blocks all phases instead of only the affected ones (see Chapter 1.3.2)
2nd Harm Ratio	% (Idiff)	5 – 50	1	15	Second harmonic restraint ratio related to the <i>basic harmonic of the differential current</i>
5th Harm Ratio	% (Idiff)	5 – 50	1	15	Fifth harmonic restraint ratio related to the <i>basic harmonic of the differential current</i>
Cross Blocking Limit	msec	100 – 60000	1	5000	After expiration the phases that still have high harmonic content will remain blocked, the others are released

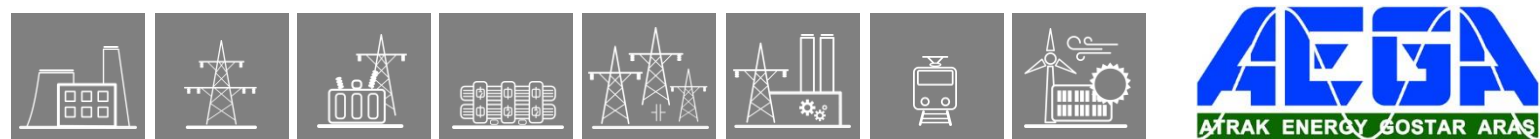

2.1.36.2.2. Function I/O

This section describes briefly the analogue and digital inputs and outputs of the function block.

2.1.36.2.2.1. Analogue inputs

The function uses the sampled values of the three phase currents of each side.

2.1.36.2.2.2. Analogue outputs (measurements)

The measured values of the differential protection function are listed in the table below.

Table 2-2 The measured analogue values of the differential protection function

MEASURED VALUE	DIMENSION	EXPLANATION
Differential current L1	In %	The calculated differential current in measuring element L1 (after vector group compensation)
Differential current L2	In %	The calculated differential current in measuring element L2 (after vector group compensation)
Differential current L3	In %	The calculated differential current in measuring element L3 (after vector group compensation)
Bias current L1	In %	The calculated restraint current in measuring element L1 (after vector group compensation)
Bias current L2	In %	The calculated restraint current in measuring element L2 (after vector group compensation)
Bias current L3	In %	The calculated restraint current in measuring element L3 (after vector group compensation)

Remark: The evaluated basic harmonic values of the measured input phase currents (without vector group compensation) help the commissioning of the differential protection function. These evaluations however are performed by an independent software measuring module, so this chapter excludes the description of these measurements.

2.1.36.2.2.3. Binary input signals (graphed output statuses)

The conditions of the inputs are defined by the user, applying the graphic equation editor (logic editor). The part written in **bold** is seen on the function block in the logic editor.

Table 2-3 The binary input signal of the differential protection function

BINARY INPUT SIGNAL	EXPLANATION
DIF87_ Bik _GrO_	Output status of a graphic equation defined by the user to disable the differential protection function. Only the measurements work and are displayed.

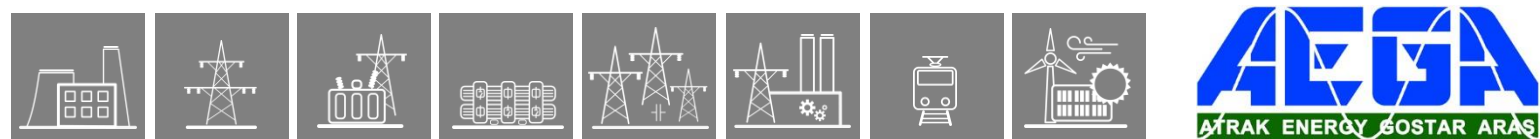

2.1.36.2.2.5. On-line data

Visible values on the on-line data page:

Table 2-5 On-line data of the differential protection function

SIGNAL TITLE	DIMENSION	EXPLANATION
Differential current L1	In %	The calculated differential current in measuring element L1 (after vector group compensation)
Differential current L2	In %	The calculated differential current in measuring element L2 (after vector group compensation)
Differential current L3	In %	The calculated differential current in measuring element L3 (after vector group compensation)
Bias current L1	In %	The calculated restraint current in measuring element L1 (after vector group compensation)
Bias current L2	In %	The calculated restraint current in measuring element L2 (after vector group compensation)
Bias current L3	In %	The calculated restraint current in measuring element L3 (after vector group compensation)
Inrush L1	-	Restraint caused by high second harmonic content in L1 differential current during inrush or external fault
Inrush L2	-	Restraint caused by high second harmonic content in L2 differential current during inrush or external fault
Inrush L3	-	Restraint caused by high second harmonic content in L3 differential current during inrush or external fault
Inrush	-	Restraint caused by high second harmonic content in any of the differential currents during inrush or external fault
5.Harm Restr. L1	-	Restraint caused by high fifth harmonic content in L1 differential current
5.Harm Restr. L2	-	Restraint caused by high fifth harmonic content in L2 differential current
5.Harm Restr. L3	-	Restraint caused by high fifth harmonic content in L3 differential current
5.Harm Restraint	-	Restraint caused by high fifth harmonic content in any of the differential currents
Start L1	-	Start of the restrained differential protection function in measuring element L1 (after vector group compensation)
Start L2	-	Start of the restrained differential protection function in measuring element L2 (after vector group compensation)
Start L3	-	Start of the restrained differential protection function in measuring element L3 (after vector group compensation)
General Start	-	General start of the restrained differential protection function
Start L1 - unrestrained	-	Start of the unrestrained differential protection function in measuring element L1 (after vector group compensation)
Start L2 - unrestrained	-	Start of the unrestrained differential protection function in measuring element L2 (after vector group compensation)
Start L3 - unrestrained	-	Start of the unrestrained differential protection function in measuring element L3 (after vector group compensation)
General Start - unrestrained	-	General start of the unrestrained differential protection function

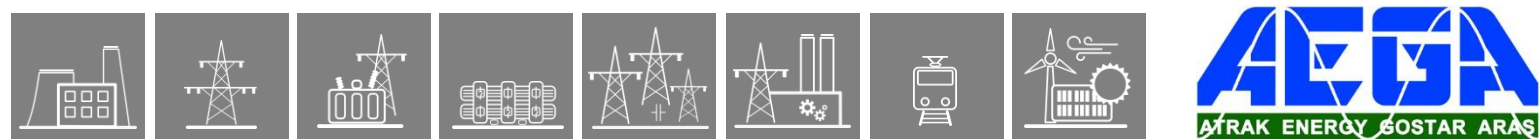

2.1.36.2.2.6. Events

The following events are generated in the event list, as well as sent to SCADA according to the configuration.

Table 2-6 Events of the differential protection function

EVENT	VALUE	EXPLANATION
Inrush L1	off, on	Restraint in phase L1 caused by high second harmonic content in the differential current during inrush or external fault
Inrush L2	off, on	Restraint in phase L2 caused by high second harmonic content in the differential current during inrush or external fault
Inrush L3	off, on	Restraint in phase L3 caused by high second harmonic content in the differential current during inrush or external fault
Start L1	off, on	Start of the restrained differential protection function in measuring element L1 (after vector group compensation)
Start L2	off, on	Start of the restrained differential protection function in measuring element L2 (after vector group compensation)
Start L3	off, on	Start of the restrained differential protection function in measuring element L3 (after vector group compensation)
General Start	off, on	General start of the restrained part of the differential protection function
Start L1 – unrestrained	off, on	Start of the unrestrained differential protection function in measuring element L1 (after vector group compensation)
Start L2 – unrestrained	off, on	Start of the unrestrained differential protection function in measuring element L2 (after vector group compensation)
Start L3 – unrestrained	off, on	Start of the unrestrained differential protection function in measuring element L3 (after vector group compensation)
General Start – unrestrained	off, on	General start of the unrestrained part of the differential protection function

2.1.36.2.3. Technical data and notes

Table 2-7 Technical data of the transformer differential protection

FUNCTION	VALUE	ACCURACY
Operating characteristic	2 breakpoints	
Reset ratio	0,9	
Characteristic accuracy*		<3%
Operate time, unrestrained	Typically 20 ms	<10 ms
Reset time, unrestrained	Typically <55 ms	
Operate time, restrained	Typically 30 ms*	<10 ms
Reset time, restrained	Typically <35 ms	

*Bias current is above $0.2 I_n$; see Chapter 2.3.2 for more information

2.1.36.2.3.1. Notes for testing

There is an XRIO setting file available for the function. With that, only the parameters of the CT modules and the differential protection function should be entered along the type of the fault to be generated. By using this file, testing the operation characteristic will not need any further setting.

Normally in the EuroProt+ devices the trip contacts are assigned to the Trip Logic function block, and not to the protection function blocks. Because of this the testing personnel must make sure that the Trip Logic is switched on ('Operation' parameter is set to other than 'Off') before starting the testing, otherwise there will be no physical trip on the relay.

Notes for testing the operation characteristics:

- Direction settings in the CT4 module function are 'Line' and 'Bus'. However, in case of differential protection 'Line' means 'Towards protected object'. So if the two CTs' starpoints are towards protected object, their settings should be 'Line' for both. (with XRIO file this point is obsolete)
- Reference winding is the delta side (see Chapter 1.1.2). Reference current is the nominal current of the transformer (see Chapter 1.1.1). (with XRIO file this point is obsolete)
- When setting up the characteristics in the relay tester, and when checking the results, keep in mind that the currents are transformed to the delta side, which results in different behavior compared to the applications of other manufacturers. (with XRIO file this point is obsolete)
- The adaptive characteristics to external faults might cause different test results, as the characteristics will be different under certain circumstances (see Chapter 1.6.3). To avoid this, the pre-fault currents should not exceed $1 * I_n$.
If the pre-fault currents cannot be adjusted, then setting the *pre-fault time to zero* also solves the issue.

Notes for testing the harmonic restraint characteristic:

- When testing the **2nd harmonic** restraint, keep in mind that either of the two conditions (inrush or external fault, see Chapter 1.3) must be fulfilled to activate the restraint along with the condition of the differential current to be at least $0.1 I_n$.
- The **5th harmonic** restraint can be tested freely the condition of the differential current to be at least $0.1 I_n$.

2.1.36.2.3.2. CT sizing requirements

The CT sizing guidelines for internal and external faults (according to the IEC60255-187-1 standard) can be acquired on request from Protecta personnel on application@protecta.hu

2.1.36.2.3.3. Transformer and primary CT rated current ratios

When ordering a device with differential protection, it must be taken into consideration that the function's characteristics are based on the *transformer's rated current*. This means that the rated currents of the primary CTs shall be selected in a way that their secondary currents are reasonably high to be measured accurately on the protection device's CT modules.

The desirable value for the primary CTs' rated current would be close to that of the transformer's rated currents, so that their measurements stay accurate for the differential protection.

For example, let's take a transformer with the following data:

$$\begin{aligned} S_n &= 50 \text{ MVA} \\ U_{n1} &= 230 \text{ kV} \\ U_{n2} &= 11 \text{ kV} \end{aligned}$$

The reference currents (transformer rated currents) on the primary and secondary sides in this case are:

$$\begin{aligned} I_{reference1} &= \frac{S_n}{\sqrt{3} U_{n1}} \rightarrow I_{reference1} = 125.5 \text{ A} \\ I_{reference2} &= \frac{S_n}{\sqrt{3} U_{n2}} \rightarrow I_{reference2} = 1207.2 \text{ A} \end{aligned}$$

Staying at the example, if a CT with a rated current of 2000A is installed on the *primary (1)* side, and another CT with 1500A on the *secondary (2)* side, the matching ratios between the transformer's and the CT's rated currents would be the following:

$$\begin{aligned} TR_1 &= \frac{I_{TRn1}}{I_{CTn1}} \rightarrow TR_1 = \frac{125.5 \text{ A}}{2000 \text{ A}} = 0.06275 = 6.275\% \\ TR_2 &= \frac{I_{TRn2}}{I_{CTn2}} \rightarrow TR_2 = \frac{1207.2 \text{ A}}{3000 \text{ A}} = 0.4024 = 40.24\% \end{aligned}$$

The issue is on the primary side, where a rated current (100%) flowing on the transformer would represent only **6.275%** on the CT. In other words, if 6.275% current (62.75 mA on 1A rated secondary) is flowing on the primary side and no current on the secondary side, the differential protection function will show 100% differential current on its on-line data. With a base sensitivity setting of 20%, 12.55 mA current (1.255%) could already cause the function to operate.

2.1.36.2.3.3.1. Recommended CT/TR nominal current matching ratios

Because of the issue above, applying the function to different matching ratios might provide different accuracy results (the lower the ratio, the better the accuracy); this also depends on the function block settings, see the table below.

Table 2-8 Characteristic accuracy depending on the CT/TR matching ratio

CHARACTERISTICS' PARAMETERS		MATCHING RATIO (PRIMARY SIDE)*		
BASE SENSITIVITY	1ST SLOPE	7 (14.29%)	12 (8.33%)	16 (6.25%)
10% (minimum)	10% (minimum)	3%	6%	10%
20% (default)	20% (default)	3%	4%	7%
20% (default)	30%	3%	3%	5%

*CT/TR ratio on the secondary side is constant (40%, see the example above)

The 3% accuracy shown in [Table 2-7](#) with the base sensitivity of 20% can be expected with a matching ratio of **7 or lower** (or higher than 14.29% if shown in TR/CT ratio instead).

If the 1st slope is at least 20% as well (default setting), the same accuracy can be reached until the ratio of **12**.

2.1.36.3. Appendix

2.1.36.3.1. Current distribution inside the Y/d transformers

For the explanation the following positive directions are applied:

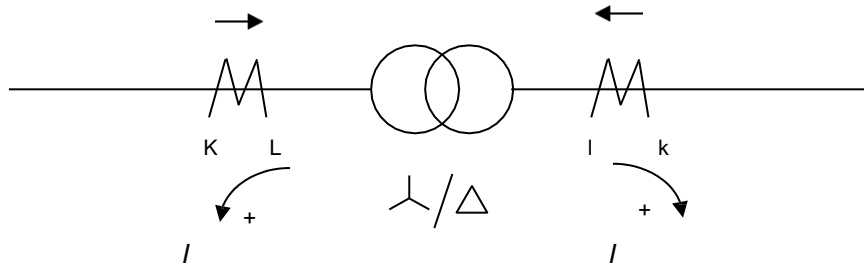

Figure 3-1 Positive directions.

2.1.36.3.1.1. Three-phase fault (or normal load state)

The figure below shows the current distribution inside the transformers in case of three-phase fault or at normal, symmetrical load state:

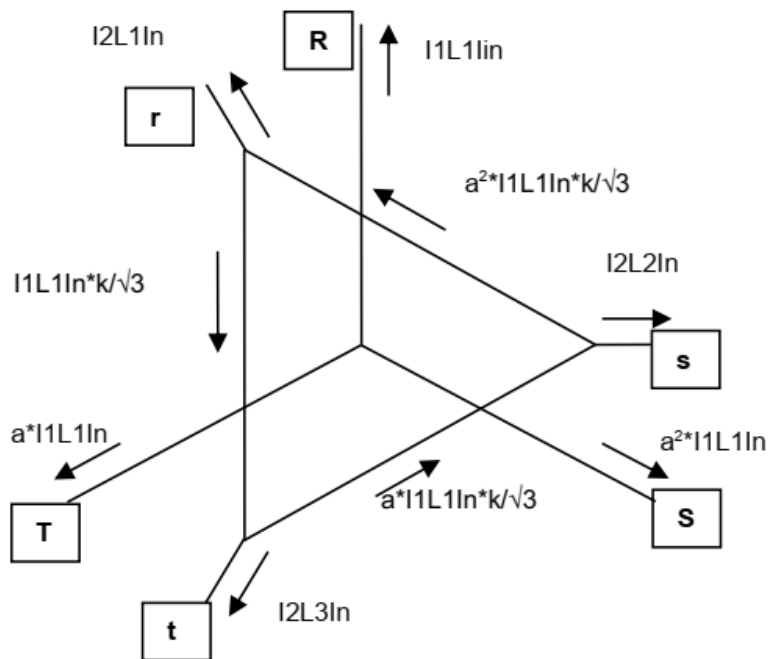

Figure 3-2 Currents in case of normal load (or three-phase fault)

On this figure k is the current ratio. The positive directions are supposed to be directed out of the transformer on both sides, as it is supposed by the differential protection. (If the directions suppose currents flowing through the transformer, then

$$I_{2L1} In = k \cdot I / \sqrt{3} \cdot (a^2 - 1)$$

This indicates that the connection group of this transformer is Yd11.

Here the primary currents form a symmetrical system:

$$\begin{bmatrix} I_{1L1/n} \\ I_{1L2/n} \\ I_{1L3/n} \end{bmatrix} = I \begin{bmatrix} 1 \\ a^2 \\ a \end{bmatrix}$$

The secondary currents can be seen on the figure (please consider the division factor $\sqrt{3}$ in the effective turn's ratio):

$$\begin{bmatrix} I_{2L1/n} \\ I_{2L2/n} \\ I_{2L3/n} \end{bmatrix} = k * I \frac{1}{\sqrt{3}} \begin{bmatrix} (a^2 - 1) \\ (a - a^2) \\ (1 - a) \end{bmatrix}$$

2.1.36.3.1.2. Phase-to-phase fault on the Y side

Assume I current on the primary Y side between phases S ($\equiv L2$) and T ($\equiv L3$).

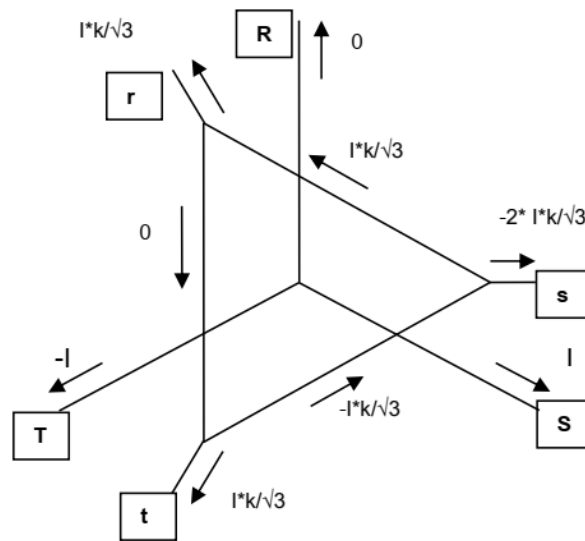

Figure 3-3 Currents inside the transformer at ST fault on the Y side

On this figure k is the current ratio.

The Y side currents are:

$$\begin{bmatrix} I_{1L1/n} \\ I_{1L2/n} \\ I_{1L3/n} \end{bmatrix} = I \begin{bmatrix} 0 \\ 1 \\ -1 \end{bmatrix}$$

The delta side currents can be seen on this figure:

$$\begin{bmatrix} I_{2L1/n} \\ I_{2L2/n} \\ I_{2L3/n} \end{bmatrix} = k * \frac{1}{\sqrt{3}} * I \begin{bmatrix} 1 \\ -2 \\ 1 \end{bmatrix}$$

2.1.36.3.1.3. Phase-to-phase fault at the delta side

Assume I current on the secondary delta side between phases “s” ($\equiv L2$) and “t” ($\equiv L3$).

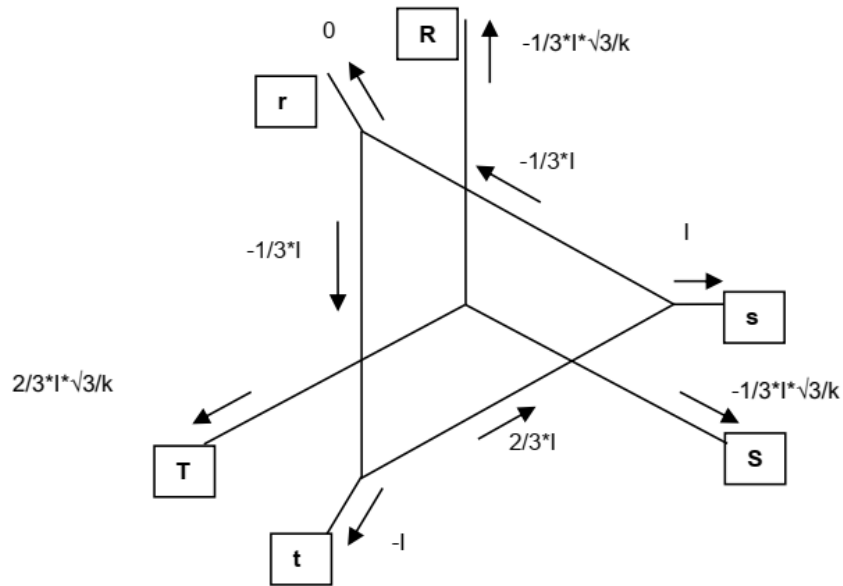

.Figure 3-4 Currents inside the transformer at “st” fault on the delta side

On this figure k is the current ratio.

The secondary currents are:

$$\begin{bmatrix} I_{2L1n} \\ I_{2L2n} \\ I_{2L3n} \end{bmatrix} = I \begin{bmatrix} 0 \\ 1 \\ -1 \end{bmatrix}$$

These are distributed in the delta supposing $2/3 : 1/3$ distribution factor. So the primary Y side currents can be seen on this figure:

$$\begin{bmatrix} I_{1L1n} \\ I_{1L2n} \\ I_{1L3n} \end{bmatrix} = \frac{1}{k} * \frac{\sqrt{3}}{3} * I \begin{bmatrix} -1 \\ -1 \\ 2 \end{bmatrix}$$

2.1.36.3.1.4. Single phase external fault at the Y side

- Assume I fault current in the phase R ($\equiv L1$) in case of solidly grounded neutral. No power supply is supposed at the delta side:

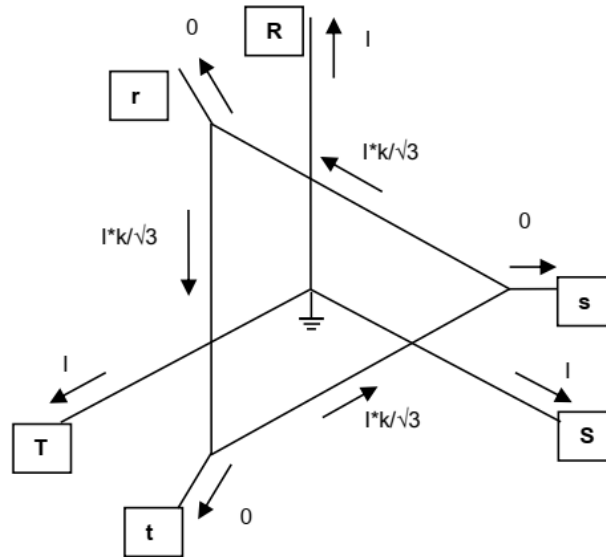

Figure 3-5 Currents inside the transformer at single phase fault at the Y side (Bauch effect)

On this figure k is the current ratio.

The primary Y side currents are:

$$\begin{bmatrix} I_{L1In} \\ I_{L2In} \\ I_{L3In} \end{bmatrix} = I \begin{bmatrix} 1 \\ 1 \\ 1 \end{bmatrix}$$

On the delta side there are no currents flowing out of the transformer:

$$\begin{bmatrix} I_{L1In} \\ I_{L2In} \\ I_{L3In} \end{bmatrix} = I \begin{bmatrix} 0 \\ 0 \\ 0 \end{bmatrix}$$

- Assume I fault current at the Y side in phase R ($\equiv L1$) in case of solidly grounded neutral. Assume the power supply at the delta side:

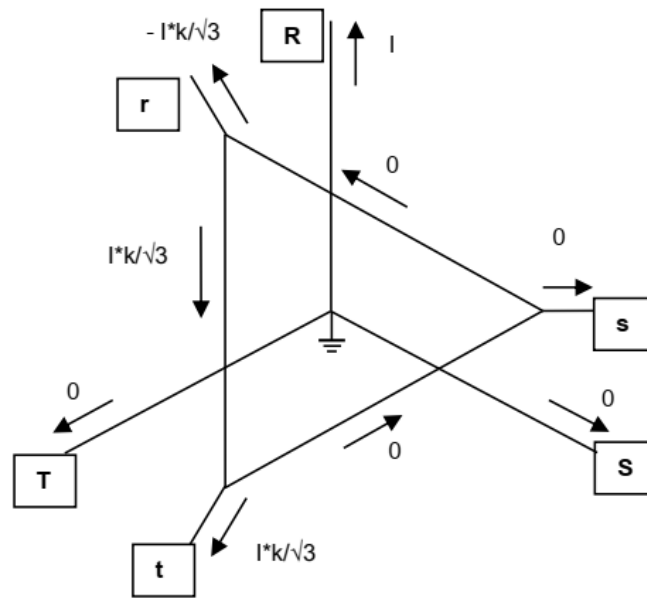

Figure 3-6 Currents inside the transformer at single phase fault at the Y side, supply at the delta side

On this figure k is the current ratio.

The primary Y side

$$\begin{bmatrix} I_{1L1ln} \\ I_{1L2ln} \\ I_{1L3ln} \end{bmatrix} = I \begin{bmatrix} 1 \\ 0 \\ 0 \end{bmatrix} \quad \text{currents are:}$$

The delta side currents can be seen on this figure:

$$\begin{bmatrix} I_{2L1ln} \\ I_{2L2ln} \\ I_{2L3ln} \end{bmatrix} = k * \frac{1}{\sqrt{3}} * I \begin{bmatrix} -1 \\ 0 \\ 1 \end{bmatrix}$$

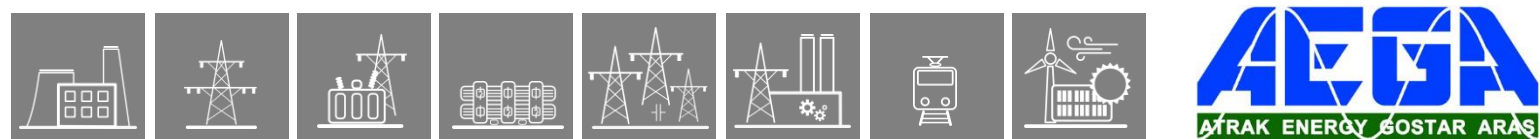

Based on the figure above, with positive directions out of the transformer the currents in the CTs are:

On the Y side (location X in Fig. 2-7):

$$\begin{bmatrix} I_{1L1In} \\ I_{1L2In} \\ I_{1L3In} \end{bmatrix} = I\sqrt{3}/k \begin{bmatrix} -1 \\ 1 \\ 0 \end{bmatrix}$$

The delta side currents at the location „Y”:

$$\begin{bmatrix} I_{2L1In} \\ I_{2L2In} \\ I_{2L3In} \end{bmatrix} = I \begin{bmatrix} 2 \\ -1 \\ -1 \end{bmatrix}$$

If the current is measured at location „Z” then the node - which has to fulfill the Kirchhoff's node law – is extended by the neutral grounding transformer, but the current flowing between the neutral point and the ground is not measured and not added to the current summation. This current is the 3I₀ zero sequence component, which can be calculated as the sum of the phase currents. At location „Z” the zero sequence component has no other path to flow, but the neutral grounding transformer.

The delta side currents at the location „Z”:

$$\begin{bmatrix} I_{2L1In} \\ I_{2L2In} \\ I_{2L3In} \end{bmatrix} = I \begin{bmatrix} 3 \\ 0 \\ 0 \end{bmatrix}$$

In this case the zero sequence current is I. If the vector group compensation is for the delta side, then the transformation does not change this current, on the high voltage side however there is no zero sequence component. But anyhow the transformation would filter this component out.

In the practice this zero sequence current component is always below the rated current of the transformer, but in case of sensitive setting of the differential protection, or at mechanical application of a relay test set without any logic control this can result faulty operation of the differential protection in case of external fault.

To avoid this faulty operation there is a binary parameter in the differential protection, the effect of which is to subtract the zero sequence current component from the phase currents, if it is needed:

$$\begin{bmatrix} I_{2L1In} \\ I_{2L2In} \\ I_{2L3In} \end{bmatrix} = \begin{bmatrix} I_{2L1In}' - I_{20} \\ I_{2L2In}' - I_{20} \\ I_{2L3In}' - I_{20} \end{bmatrix} = I \begin{bmatrix} 3 \\ 0 \\ 0 \end{bmatrix} - I \begin{bmatrix} 1 \\ 1 \\ 1 \end{bmatrix} = I \begin{bmatrix} 2 \\ -1 \\ -1 \end{bmatrix}$$

It means that based on the currents of the CT-s located at „Z” the current is calculated, which could be measured at location „Y”.

REMARK: This zero sequence current subtraction could be applied without any consequences in case of current transformers at location „Y” too, because in case of external faults, at this location no zero sequence current can be detected. In case of internal fault however this decreases the faulty phase current by 2/3. This could worsen the sensitivity of the differential protection in case high impedance internal faults. The application of the mentioned binary parameter can disable the subtraction of the zero sequence current in case of measurement at location „Y”.

2.1.36.3.1.5.2. Power supply at the delta side

If on a medium voltage network with neutral grounding transformer connects distributed generators, a possible state of operation can be that the transformer is disconnected at the high voltage Y side. On the Y side no current can flow, and if the differential protection measures the currents on the medium voltage side at location „Z” (Fig. 2-8) then in case of sensitive setting of the characteristic lines or at testing, the differential protection can generate a faulty trip command. The current distribution according to Fig. 2-8 is as follows:

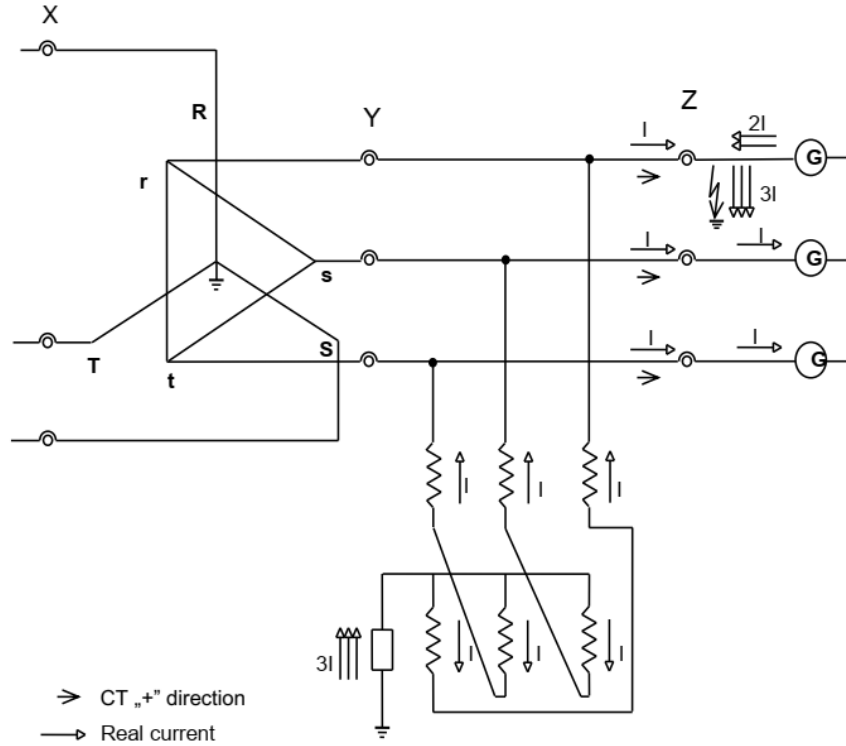

Figure 3-8 Current distribution in case of delta side single phase fault, supply at the delta side

In this case no current is detected at the point „X” (CB open):

$$\begin{bmatrix} I_{1L1In} \\ I_{1L2In} \\ I_{1L3In} \end{bmatrix} = \begin{bmatrix} 0 \\ 0 \\ 0 \end{bmatrix}$$

The measured currents at „Z” can be seen in the figure:

$$\begin{bmatrix} I_{2L1In} \\ I_{2L2In} \\ I_{2L3In} \end{bmatrix} = I \begin{bmatrix} 1 \\ 1 \\ 1 \end{bmatrix}$$

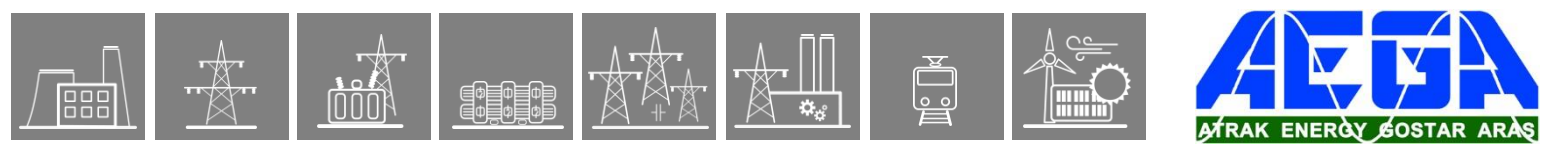

To avoid mal-operation (trip) at external fault a binary parameter is applied, the effect of which is to subtract the zero sequence current at the delta side:

$$\begin{bmatrix} I_{2L1In} \\ I_{2L2In} \\ I_{2L3In} \end{bmatrix} = \begin{bmatrix} I_{2L1In'} - I_{20} \\ I_{2L2In'} - I_{20} \\ I_{2L3In'} - I_{20} \end{bmatrix} = I \begin{bmatrix} 1 \\ 1 \\ 1 \end{bmatrix} - I \begin{bmatrix} 1 \\ 1 \\ 1 \end{bmatrix} = \begin{bmatrix} 0 \\ 0 \\ 0 \end{bmatrix}$$

It means that based on the currents of the CT-s located at „Z” the current is calculated, which could be measured at location „Y”.

With this transformation the unwanted trip is avoided.

2.1.36.4. Example for application

For the application example consider a transformer with three voltage levels, according to [Figure 1-1](#). The coils for the primary are connected Y with solidly grounded neutral. The secondary coils are delta connected, and the tertiary coils are also Y connected, but the neutral point is isolated. In this example it is supposed that no neutral grounding transformer is connected within the protected zone.

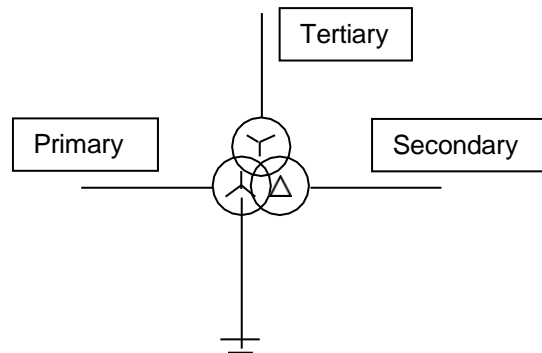

Figure 1-1 Application example

Example transformer data for the application:

Rated voltages:	$U1/U2/U3 = 120/36,75/22 \text{ kV}$
Rated power:	$S_n = 40/30/20 \text{ MVA}$
Connection group:	YNd11y6

Current transformers installed for the application are shown in [Figure 1-2](#). All P1 points are arranged towards the transformer.

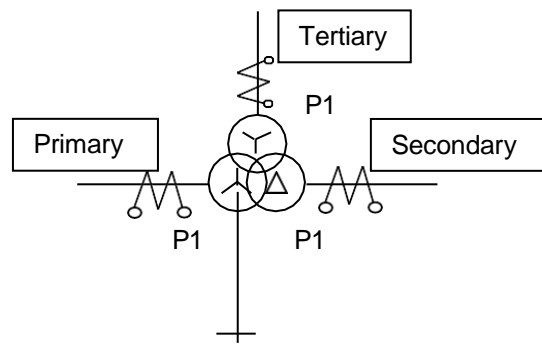

Figure 1-2 Current transformers, assigned to the differential protection function

Current transformer data:

Primary side	1000/1 A
Secondary side	500/1 A
Tertiary side	600/1 A

Suppose that the transformer is to be protected by differential protection.

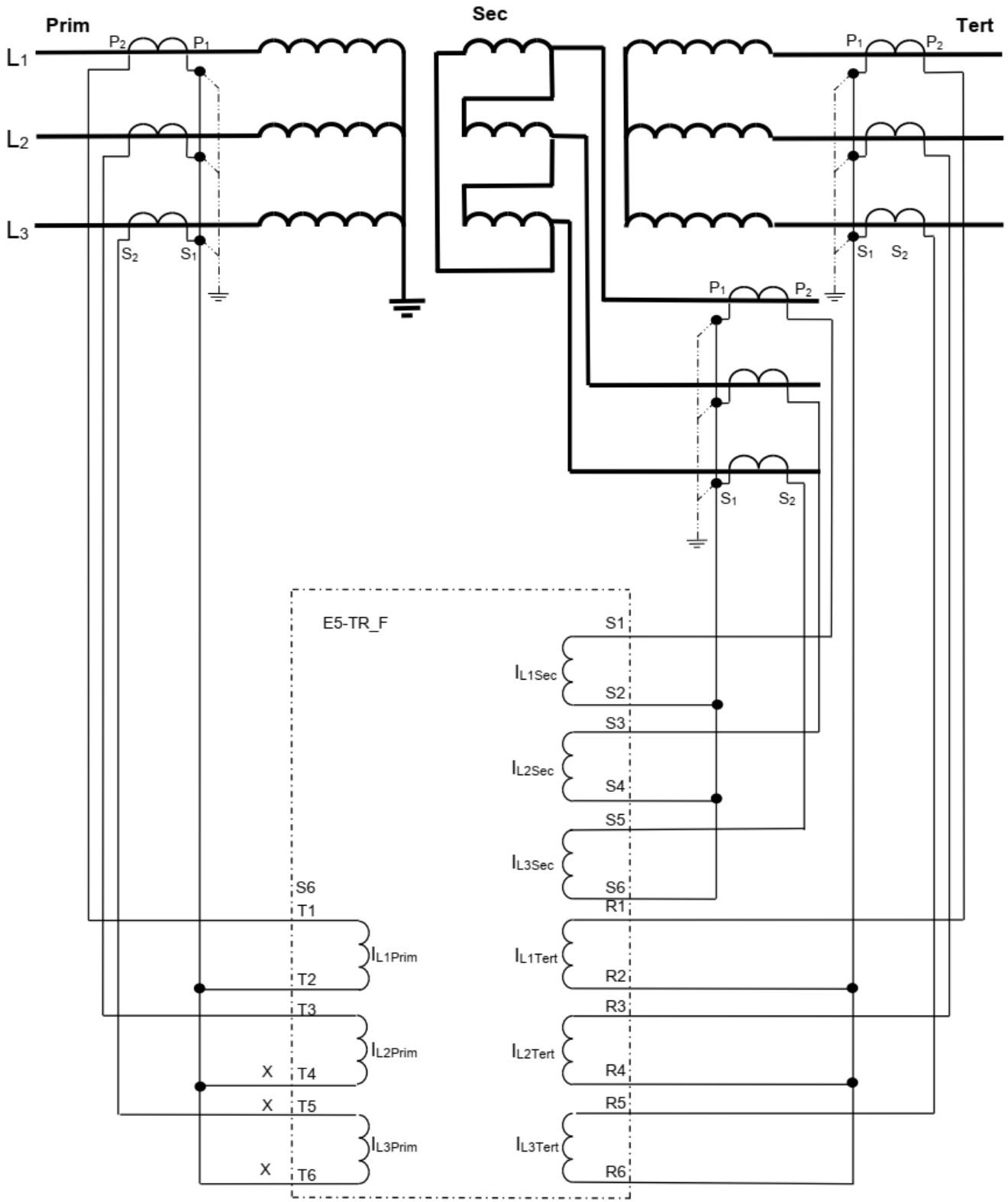

Figure 1-4 Connection diagram for the example

2.1.36.4.1. Setting the CT input function blocks

In the EuroProt+ devices the CT inputs are assigned to CT function blocks. They need parameter setting and also displaying functions are assigned to them. Parameters can be set in the parameter screen of a WEB browser, when there is Internet connection with the device. For details about this communication see the Protecta document “**Remote user interface description**” available in Protecta WEB site www.protecta.hu.

NOTE: the parameters can be set also using the local LCD touch-screen of the device, if no internet connection is available. For details about this communication see the Protecta document “**LCD touchscreen interface description**” available in Protecta WEB site www.protecta.hu.

The parameters of the current input function are explained in the following tables.

Enumerated parameters

Parameter name	Title	Selection range	Default
Rated secondary current of the first three input channels. 1A or 5A is selected by parameter setting, no hardware modification is needed.			
CT4_Ch13Nom_EPar_	Rated Secondary I1-3	1A,5A	1A
Rated secondary current of the fourth input channel. 1A or 5A (0.2A, 1A) is selected by parameter setting, no hardware modification is needed.			
CT4_Ch4Nom_EPar_	Rated Secondary I4	1A,5A (0.2A, 1A)	1A
Definition of the positive direction of the first three currents, given by location of the secondary star connection point			
CT4_Ch13Dir_EPar_	Starpoint I1-3	Line,Bus	Line
Definition of the positive direction of the fourth current, given as normal or inverted			
CT4_Ch4Dir_EPar_	Direction I4	Normal,Inverted	Normal

Table 2-1 The enumerated parameters of the current input function

Floating point parameters

Parameter name	Title	Dim.	Min	Max	Default
Rated primary current of channel1-3					
CT4_Pr113_FPar_	Rated Primary I1-3	A	100	4000	1000
Rated primary current of channel4					
CT4_Pr114_FPar_	Rated Primary I4	A	100	4000	1000

Table 2-2 The floating point parameters of the current input function

NOTE: The rated primary current of the channels is not needed for the current input function block itself. These values are passed on to the subsequent function blocks.

Using the information given in this example above, the following setting values are assigned:

Primary side and grounding CT:

Rated Secondary I1-3	1A	Selected, according to the CT applied at the primary side.
Rated Secondary I4	1A	Not applied, the value is not considered.
Starpoint I1-3	Line	“Line” in this case means “Toward protected object = Transformer”
Direction I4		Not applied, the value is not considered.
Rated Primary I1-3	1000	Setting, according to the CT applied at the primary side. This parameter is used for scaling the displayed values only
Rated Primary I4		Not applied, the value is not considered.

Secondary side:

Rated Secondary I1-3	1A	Selected, according to the CT applied at the secondary side.
Rated Secondary I4		Not applied, the value is not considered.
Starpoint I1-3	Line	“Line” in this case means “Toward protected object = Transformer”
Direction I4		Not applied, the value is not considered.
Rated Primary I1-3	500	Setting, according to the CT applied at the secondary side. This parameter is used for scaling the displayed values only
Rated Primary I4		Not applied, the value is not considered.

Tertiary side:

Rated Secondary I1-3	1A	Selected, according to the CT applied at the tertiary side.
Rated Secondary I4		Not applied, the value is not considered.
Starpoint I1-3	Line	“Line” in this case means “Toward protected object = Transformer”
Direction I4		Not applied, the value is not considered.
Rated Primary I1-3	600	Setting, according to the CT applied at the tertiary side. This parameter is used for scaling the displayed values only
Rated Primary I4		Not applied, the value is not considered.

Table 2-3 Summary of the CT parameter setting

2.1.36.4.2. Parameter setting for the differential function

The parameters with the selected settings for the example application for the differential protection function are summarized in [Table 3-1](#) below. Some parameters need basic considerations some of them need also calculation. This is explained in the paragraphs below:

Operation	On	Set this parameter to “On” for enabling the function. NOTE: In tests, when other protection functions are tested. Switch this parameter to “Off” to prevent false test results. The details see in paragraph 3.1
Pri-Sec VGroup	Yy6	This setting is selected according to the protected object. NOTE: see explanation in paragraph 3.2
Pri-Ter VGroup	Yd11	This setting is selected according to the protected object. (Example) NOTE: see explanation in paragraph 3.2

Zero Seq Elimination	False	Not checked. This parameter is needed only if there is isolated (Not grounded) side of the transformer and there is and additional neutral grounding transformer within the protected zone. As this additional neutral grounding transformer is not supposed to be present, the checkbox can remain unchecked. This is described in paragraph 3.6
TR Primary Comp	20	This value needs calculation. This is described in paragraph 3.3
TR Secondary Comp	132	This value needs calculation. This is described in paragraph 3.3
TR Tertiary Comp	184	This value needs calculation. This is described in paragraph 3.3
2nd Harm Ratio	15	This value needs some considerations. These are described in paragraph 3.4
5nd Harm Ratio	25	This value needs some considerations. These are described in paragraph 3.4
Base Sensitivity	50	Parameter for the differential characteristic. This value needs some considerations. These are described in paragraph 3.5
1st Slope	50	Parameter for the differential characteristic. This value needs some considerations. These are described in paragraph 3.5
1st Slope Bias Limit	400	Parameter for the differential characteristic. This value needs some considerations. These are described in paragraph 3.5
UnRst Diff Current	800	Parameter for the differential characteristic. This value needs some considerations. These are described in paragraph 3.5

Table 3-1 Summary of the differential protection parameter setting

2.1.36.4.2.1. Enabling the differential protection function

The DIF87 differential protection function can be applied as main protection for transformers, generators, large motors and also for protection of lines or cables on solidly grounded networks, or any combination of the mentioned protected objects.

The version DIF87_3w can be applied to protect transformers with three voltage levels. The simpler version DIF87_2w is designed to protect two winding transformers.

The parameter for enabling the differential protection function is shown in table below:

Parameter name	Title	Selection range	Default
Parameter to enable the differential protection function:			
DIF87_Op_EPar_	Operation	Off, On	Off

For enabling the function, set this Boolean parameter:

„Operation” = „On”

Additionally the differential protection function block has a binary input signal: „Blk”. In active state of this input signal the function is blocked. The conditions for blocking can be programmed using the graphic logic editor

2.1.36.4.2.2. Setting the vector compensation

A three-phase transformer transforms the primary current to the secondary side according to the turn's ratio and the connection of the coils. The connection of the coils Y (star), D (delta) or Z (zig-zag) results phase shift of the current vectors. The numerical transformer differential protection function applies matrix transformation for the phase currents, according to the connection group to match them on all sides of the transformer.

The required matrix transformation is defined by correct selection of the transformer's connection group.

The transformer differential protection function in Protecta EuroProt+ devices transforms all currents to the delta side. This method is the numerical realization of the traditional principle: connect the secondary coils of the current transformers on the Y side of the transformer to delta, and apply y connection of the CT secondary coils on the delta side of the transformer. This transformation automatically eliminates also the problem caused by zero sequence current components.

Parameters for matching the vector group of the transformer are listed in the table below:

Parameter name	Title	Selection range	Default
Parameter to select connection_group of the transformer coils in primary-secondary relation:			
DIF87_VGrSec_EPar_	Pri-Sec VGroup*	Dy1,Dy5,Dy7,Dy11,Dd0,Dd6,Dz0,Dz2,Dz4,Dz6,Dz8,Dz10,Yy0,Yy6,Yd1,Yd5,Yd7,Yd11,Yz1,Yz5,Yz7,Yz11	Dd0
Parameter to select connection_group of the transformer coils in primary-secondary relation:			
DIF87_VGrTer_EPar_	Pri-Ter VGroup*	Dy1,Dy5,Dy7,Dy11,Dd0,Dd6,Dz0,Dz2,Dz4,Dz6,Dz8,Dz10,Yy0,Yy6,Yd1,Yd5,Yd7,Yd11,Yz1,Yz5,Yz7,Yz11	Dd0

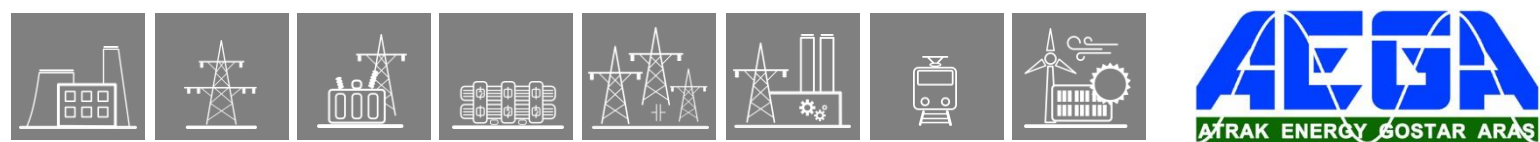

* If the connection of the primary winding in primary-secondary and primary tertiary relation is selected in contradiction then the protection function is automatically disabled, and the function generates a warning signal.

The selection of these parameters is easy: select the real connection relationship of the protected transformer. For autotransformers select always Yy0.

If the protection function is applied to protect the unit of transformer-line or transformer-cable then the parameters should be selected as the connection group can be seen from the location of the protection. As an example: a transformer of Yd11 connection group is seen at the other side as a transformer Dy1.

2.1.36.4.2.3. Setting the magnitude matching

The basic principle is that in case of power transfer at rated current the currents to be compared should be the same, 100%. This means that in case of any external faults there will be no current difference, the differential function is balanced and stable.

For a two winding transformer, usually the rated current of the transformer is considered to be the base current, considered to be 100%. (NOTE: any other current value could also be selected for this reference current.) The ratio of the secondary and primary rated currents is the turn's ratio of the transformer. For the setting calculation, calculate the ratio of the transformer rated current and the CT rated primary current. These values expressed in % are the parameter values to be set for parameters „TR Primary Comp” and “TR Secondary Comp”.

For a three winding transformer in the example the rated power of the winding is not the same (40 MVA, 30 MVA and 20 MVA), consequently the ratio of rated currents for the windings do not match the turn's ratio of the coils. In this case the usual procedure is to consider the rated current of the primary side, and transform this current both for the secondary and to the tertiary side. These calculated currents should be related to the rated currents of the CT-s. These values expressed in % are the parameter values to be set for parameters „TR Primary Comp”, “TR Secondary Comp” and “TR Tertiary Comp”

In the example:

The rated primary current is calculated from the transformer data above. This is the reference current.

$$I_{1n\text{primary}} = 192 \text{ A}$$

$$I_{2n\text{primary}} = 471 \text{ A} \quad \text{based on the turn's ratio it is:} \quad 627 \text{ A}$$

$$I_{3n\text{primary}} = 525 \text{ A} \quad \text{based on the turn's ratio it is:} \quad 1047 \text{ A}$$

The calculation of the setting values is as follows

$$\text{„TR Primary Comp"} = 100 \cdot 192 \text{ A} / 1000 \text{ A} = 19.2\% \quad \text{It needs correction.}$$

$$\text{„TR Secondary Comp"} = 100 \cdot 627 \text{ A} / 500 \text{ A} = 125.4\% \quad \text{It needs correction, using the same factor}$$

$$\text{„TR Tertiary Comp"} = 100 \cdot 1047 \text{ A} / 600 \text{ A} = 174.5\% \quad \text{It needs correction, using the same factor}$$

For the 120 kV side the setting of 19% is below the low limit of the parameter range. Select instead 20 %. Consequently the compensation values both for the secondary and tertiary sides should be multiplied by 20/19. Note this correction means only that not the rated current but a slightly different value is selected as the base current.

$$\text{„TR Primary Comp"} = 20 \%$$

$$\text{„TR Secondary Comp"} = 20/19 \cdot 125.4 \% = 132 \%$$

$$\text{„TR Tertiary Comp"} = 20/19 \cdot 174.5 \% = 184 \%$$

2.1.36.4.2.4. Considerations, related to the harmonic restraint

When a transformer is energized then due to the asymmetric saturation of the iron core a high “inrush current” can flow from one side into the transformer. This is a pure differential current. To prevent unwanted operation of the differential protection the special waveform of the inrush current is identified. The principle is the detection of the second harmonic content, which is present in the inrush current, but its value can be neglected in any fault current. For the differential current, the second harmonic component in the evaluation is related to the value of the base harmonic. This is the parameter „2nd Harm Ratio”. If this ratio gets higher due to inrush current, the trip command is blocked.

When a transformer is overexcited then the iron core is saturated symmetrically, resulting high current peaks, distorting both the positive and the negative sinusoidal current shape. In this current shape the fifth harmonic is characteristic. To prevent mal-operation, this component of the differential current is analyzed and compared to the base harmonic. If the ratio is high, then the differential current is caused by the over-excitation, the trip command is blocked. If however the fifth harmonic content is low, then the high differential current, which is a fault current, results trip command. The ratio is the parameter „5th Harm Ratio”.

If no results of detailed harmonic analysis are available, apply the factory setting, which can be corrected later. The proposed setting values are:

$$\text{„2nd Harm Ratio”} = 15 \%$$

and

$$\text{„5th Harm Ratio”} = 25 \%$$

2.1.36.4.3. Considerations, related to the differential characteristic for the differential protection function

The differential characteristic is shown in *Figure 3-1*. If the calculated ($I_{\text{bias}}, I_{\text{diff}}$) operating point is above the characteristic, then the differential protection operates.

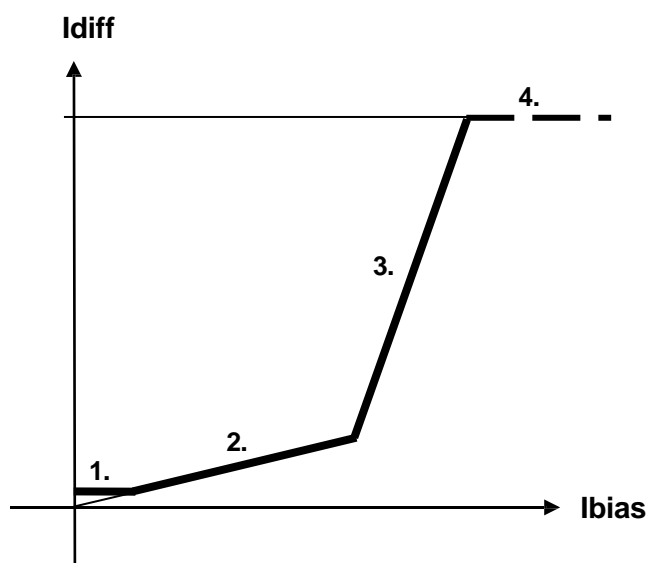
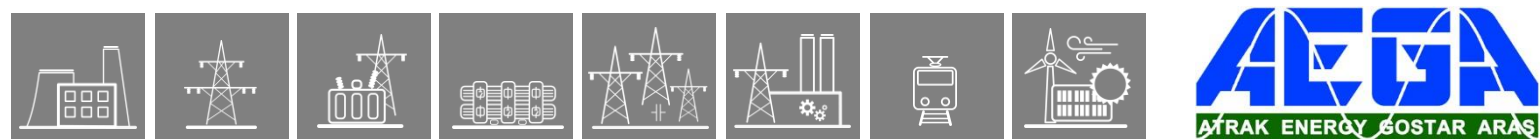

Figure 3-1 The differential characteristic

This characteristic has four sections; each of them is a straight line. The parameters define the position of these lines on the I_{diff} - I_{bias} plane.

The first parameter is “Base Sensitivity”. It defines the minimum differential current for the operation. Its role is to prevent mal-operation in case of current noises and measuring errors for small currents. In this example the selected setting value is the less sensitive selection:



„Base Sensitivity” = 50 %,

This value can be tested easily: inject three phase symmetrical currents from one side only and increase its value. The operation is expected if this current gets above 50% of the reference current. (In this example it is $0.5 \cdot 0.87A$. NOTE: for asymmetrical fault current this value changes due to the matrix transformation.)

The second section of the characteristic is a line through the origin of the I_{diff} - I_{bias} plane. The slope of this line serves to compensate the not correct matching of the CT-s, e.g. due to the different tap-changer positions and the CT errors. Due to these causes the error current increases if the current flowing through the transformer increases. The parameter is “1st Slope”. The mathematical expression of the second section of the characteristic is

$$I_{diff} = \frac{1stSlope}{100} * I_{bias}$$

. The steps for getting the parameter value are as follows:

- Calculate the error in percent, due to not correct matching (To be calculated for all three voltage levels):

$$x\% = \left(1 - \left| \frac{I_{\cdot} \cdot required_matching}{I_{\cdot} \cdot matching} \right| \right) * 100$$

- The unbalance of the differential protection at top or bottom position of the tap changer in percent, related to the value of 0 position ($r_{max}\%$):

$$x\% = |r_{max}\%|$$

Select the biggest value of the calculated $x\%$ values above. The setting value is advised to be above this value.

Example: suppose the voltage control range to be $+18\%/-12\%$, and the reference position for current balancing is the 0 position, then the parameter value with 1,5x safety is:

$$\text{„1st Slope”} = 1,5 \cdot 18 = 27 \rightarrow 30 \%$$

Another choice for calculation is the selection the mid-position of the tap-changer. This is in this example as follows: The full position range is $18 + 12 = 30\%$. The half value is 15% , accordingly the mid-position is $+3\%$. With this the voltage ratio of the transformer to be considered is to be increased by $118/115$, and the balancing of the current is to be determined for this voltage. In this case only $\pm 15\%$ tap position range can be considered, and the value of this parameter is decreased to:

$$\text{„1st Slope”} = 1,5 \cdot 15 = 22,5 \rightarrow 25 \%$$

The slope of the third section of the characteristic is higher. This is to compensate the increased CT error, due to the CT saturation at higher currents. This higher slope is a factory setting: 200%. The parameter “1st Slope Bias Limit” defines the intersection point of section 2 and 3.

This parameter value is influenced by the highest fault current in the protected object and the applied current transformer saturation point related to the rated value. If the current transformer is less over-dimensioned then select the parameter value for “1st Slope Bias Limit” low. The usual consideration is: for relatively high currents select 200 %, for low fault currents select 1000 %.

The fourth section of the characteristic is the unrestrained section. The related parameter is “UnRst Diff Current”. This parameter serves unrestrained fast operation if the high magnitude of the fault current indicates internal fault. The calculation determines the maximal external fault current, and the setting value should be above this current.

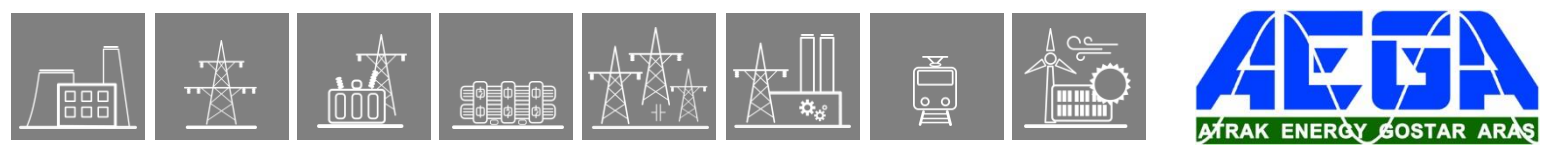

2.1.36.4.4. Considerations for zero sequence elimination

In solidly grounded high voltage networks, in case of external earth faults, the Y-delta transformers supply zero sequence current, which is present on the Y side only. No zero sequence current can flow on the delta side. When comparing the currents in the differential protection, this could cause unwanted operation.

The differential protection function in the Protecta EuroProt+ devices eliminates the Y side zero sequence current by matrix transformation (simulating the old type delta connected CT secondary behavior). This elimination is automatic, no additional solution is needed.

In several cases, however, there is additional neutral grounding transformer on the delta side of the transformer within the protected zone. Between the neutral point of this additional transformer an arc suppression Petersen coil, or a grounding resistor is connected. The Petersen coil minimizes the earth-fault current to some Amperes, the resistor limits the earth-fault current to 100 A (in some cases to 200 A).

If the neutral grounding transformer is not in the protected zone, it is outside the current transformers, then set:

„ZeroSeq Elimination” = „False” (Not checked)

In some cases, however, the neutral grounding transformer is closely connected to the main transformer's delta side terminals; it is in the protected zone. The advantage of this arrangement is that the energizing the transformer immediately solves the neutral grounding problems.

In case of external earth-fault the zero sequence current of the neutral grounding transformer is detected by the delta side current transformers. The zero sequence elimination is needed. In this case set

„ZeroSeq Elimination” = „True” (Checked)

2.1.36.4.5. Application of the binary signals

The binary output status signals are usually applied in the graphic logic editor as input signals. The logic relationship can be programmed freely.

The available binary output status signals of the differential protection function are listed in the table below:

Binary output signals	Signal title	Explanation
Restrained differential protection function		
DIF87_L1St_Grl_	Start L1	Start of the restrained differential protection function in phase L1 (after vector group compensation)
DIF87_L2St_Grl_	Start L2	Start of the restrained differential protection function in phase L2 (after vector group compensation)
DIF87_L3St_Grl_	Start L3	Start of the restrained differential protection function in phase L3 (after vector group compensation)
DIF87_GenSt_Grl	General Start	General start of the restrained differential protection function
Unrestrained differential protection function		
DIF87_UnRL1St_Grl_	Start L1 unrestr.	Start of the unrestrained differential protection function in phase L1 (after vector group compensation)
DIF87_UnRL2St_Grl_	Start L2 unrestr.	Start of the unrestrained differential protection function in phase L2 (after vector group compensation)
DIF87_UnRL3St_Grl_	Start L3 unrestr.	Start of the unrestrained differential protection function in phase L3 (after vector group compensation)
DIF87_UnRGenSt_Grl_	General Start unrestr	General start of the unrestrained differential protection function
Harmonic blocking		
DIF87_2HBlk_Grl	2.Harm Restr.	Restraint caused by high second harmonic content in any of the differential currents
DIF87_5HBlk_Grl	5.Harm Restr.	Restraint caused by high fifth harmonic content in any of the differential currents

The differential protection function has a binary input signal, which serves disabling the function. **The conditions of disabling are defined by the user, applying the graphic equation editor.**

Binary input signal	Explanation
DIF87_Blk_GrO	Output status of a graphic equation defined by the user to disable the differential protection function.

2.1.37. Restricted earth-fault protection function

The restricted earth-fault protection function is basically a low-impedance differential protection function based on zero sequence current components. It can be applied to transformers with grounded neutral. The function compares the measured neutral current at the star point and the calculated zero sequence current component of the phase currents and generates a trip command if the difference of these currents is above the characteristics.

2.1.37.1. Structure of the restricted earth-fault protection algorithm

Fig.1-1 shows the structure of the restricted earth-fault protection (DIF87N) algorithm.

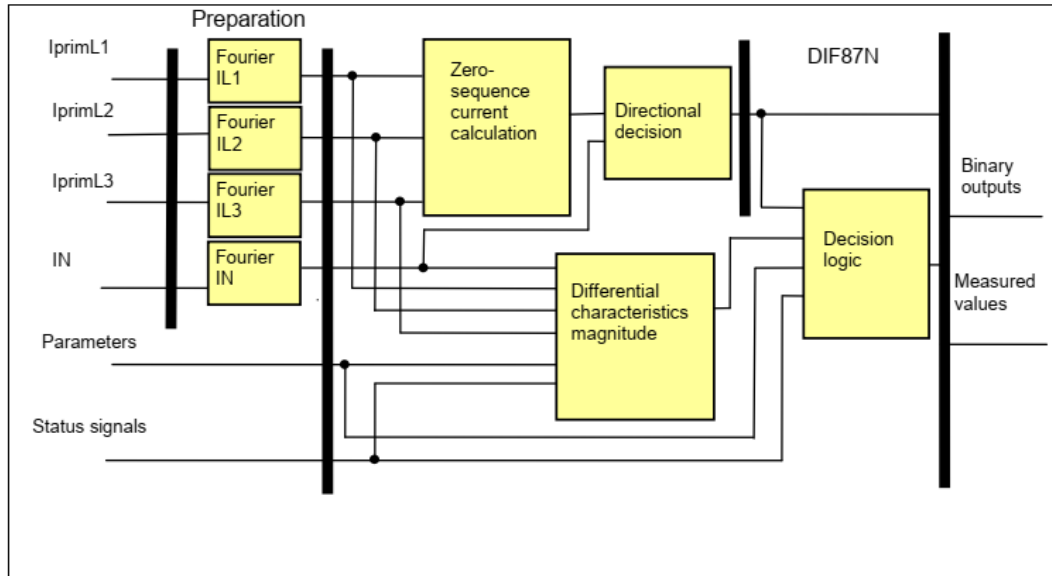

Figure 1-1 Structure of the restricted earth-fault protection algorithm

The **inputs** for the preparation are:

- the sampled values of three primary phase currents,
- the sampled value of the neutral current.

The **outputs** of the preparation are:

- the RMS values of the fundamental Fourier components of the phase currents and that of the neutral current.

The **inputs** for the DIF87N function are:

- the RMS values of the fundamental Fourier components of the phase currents and that of the neutral current,
- parameters,
- status signal.

The **outputs** of the DIF87N function are:

- the binary output status signal,
- the measured values for displaying.

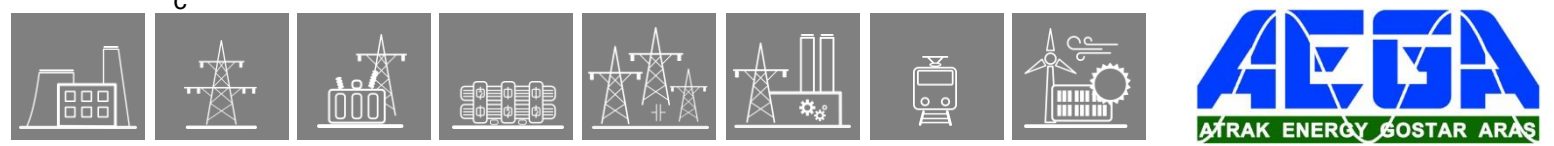

The **software modules** of the restricted earth-fault protection function:

Fourier calculations

These modules calculate the basic Fourier current components of the phase currents and that of the neutral current individually. These modules belong to the preparatory phase.

Zero sequence current calculation

This module calculates the zero sequence current components based on the Fourier components of the phase currents. These modules belong to the preparatory phase.

Directional decision

This module compares the direction of the neutral current and that of the calculated zero sequence current. In case of small zero sequence components of the high fault currents in the phases, this decision improves the stability of the function.

Differential characteristics

This module performs the necessary calculations for the evaluation of the “percentage differential characteristics” and decides if the differential current is above the characteristic curve of the restricted earth-fault protection function. This curve is the function of the restraint current, which is the maximum of the phase currents and the current of the neutral point. The result of this calculation is needed for the decision logic.

Decision logic

The decision logic module combines the status signals, binary and enumerated parameters to generate the trip command of the function.

The following description explains the details of the individual components.

2.1.37.2. The Fourier calculation (Fourier)

These modules calculate the basic Fourier current components of the phase currents and that of the neutral current individually. The magnitudes of these currents are matched to each other using the current transformer rated current values. These modules belong to the preparatory phase.

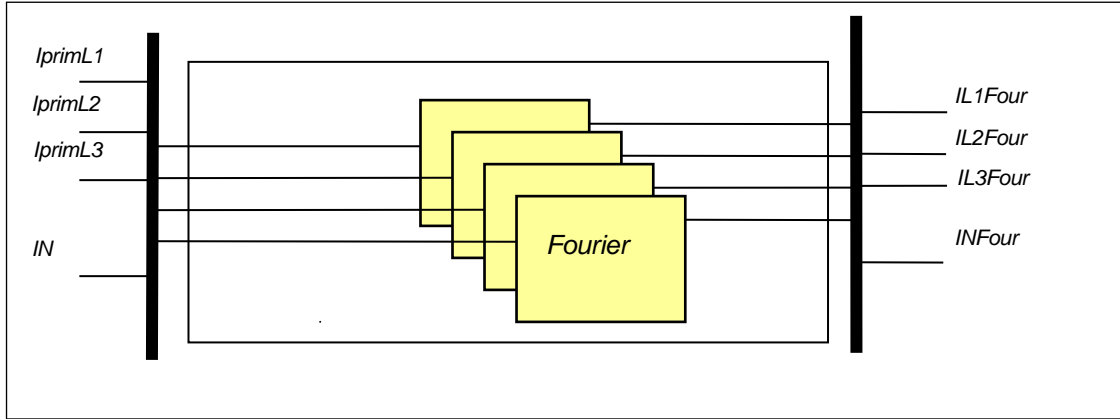

Figure 1-2 Principal scheme of the Fourier calculation

The **inputs** are the sampled values of:

- the three phase currents of the primary side (IprimL1, IprimL2, IprimL3)
- the current measured at the neutral point (IN)

The **outputs** are the basic Fourier components of the analyzed currents (IL1Four, IL2Four, IL3Four, INFour).

The **integer parameters** of the Fourier calculation are listed in (% related to the input rated current)

Table 1-1.

Parameter name	Title	Unit	Min	Max	Step	Default
Parameters for the current magnitude compensation:						
DIF87N_TRPri_IPar_	TR Primary Comp	%	20	500	1	100
DIF87N_TRNeut_IPar_	TR Neutral	%	100	1000	1	500

(% related to the input rated current)

Table 1-1 The integer parameters of the Fourier calculation

2.1.37.3. The zero sequence current calculation (Zero sequence current calculation)

This module calculates the zero sequence current component based on the Fourier components of the phase currents. This module belongs to the preparatory phase.

The **inputs** are the basic Fourier components of the phase currents (IL1Four, IL2Four, IL3Four).

The **outputs** are the Fourier components of the calculated zero sequence current (3IoFour).

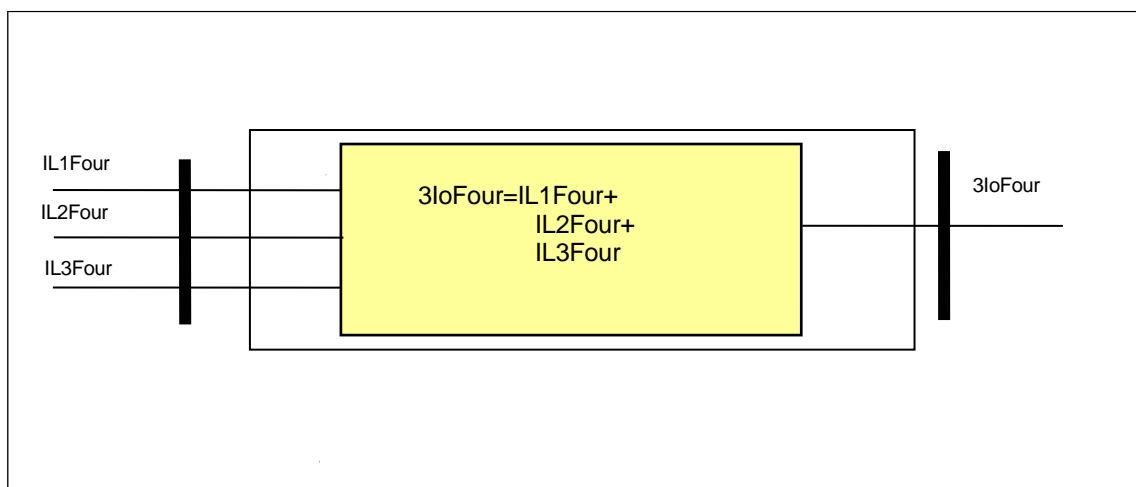

Figure 1-3 Principal scheme of the zero sequence current calculation

2.1.37.4. Directional decision (Directional decision)

This module compares the direction of the neutral current and that of the calculated zero sequence current. In case of small zero sequence component of the high fault currents in the phases, this decision improves the stability of the function.

For the directional decision, the positive directions are drawn in Figure 1-4. In this system, if the angle between the calculated zero sequence current $3I_0$ and the measured neutral current I_N is out of the range of ± 90 degrees, then the restricted earth fault protection can be blocked, the status signal DIF87N_StDir_GrI_ (Dir.element Start) is set to TRUE value.

The blocking of the directional decision is decided in the decision logic of the function, using the binary parameter DIF87N_DirCheck_BPar_.

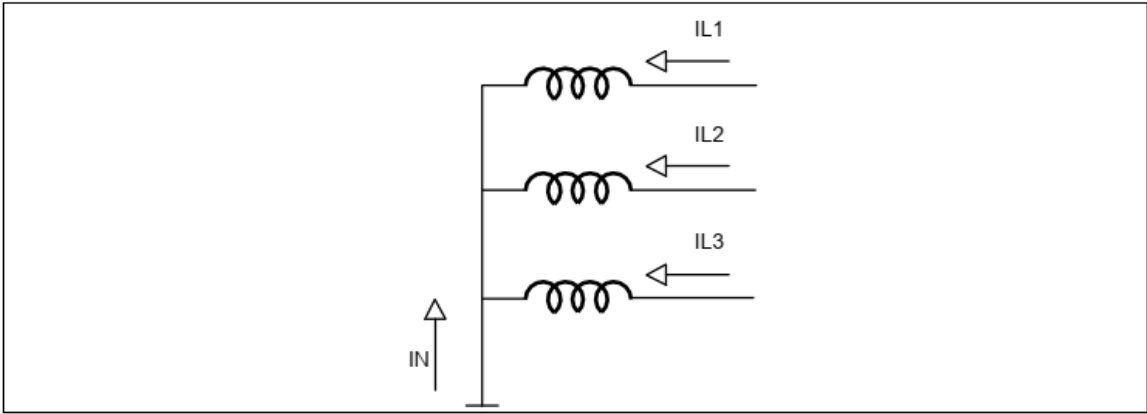

Figure 1-4 Positive directions for the directional decision

The **inputs** are the Fourier components of the calculated zero sequence current ($3I_{0Four}$) and that of the neutral current (I_{NFour}).

The **binary output status signal** of the directional decision is shown in Table 1-2.

Binary output signals	Signal title	Explanation
DIF87N_StDir_Grl_	Dir.element Start	Directional blocking signal of the zero-sequence directional element

Table 1-2 The binary output status signals of the directional decision

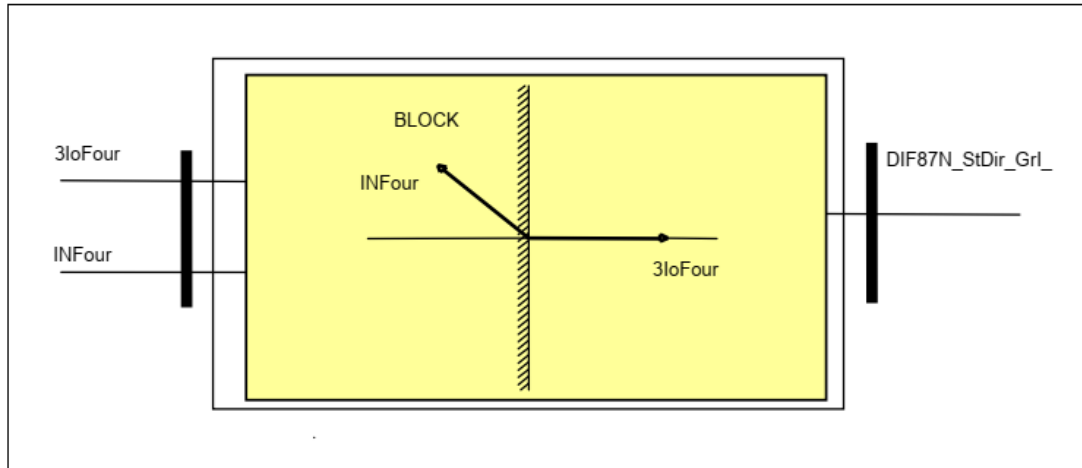

Figure 1-5 Principal scheme of the directional decision

2.1.37.5. The zero sequence differential characteristics (Differential characteristics)

This module performs the necessary calculations for the evaluation of the “percentage differential characteristics”, and decides if the differential current is above the characteristic curve of the zero sequence differential protection (restricted earth-fault protection) function. This curve is the function of the restraint current, which is the maximum of the phase currents and the current of the neutral point. The result of this calculation is processed in the decision logic.

The differential current is calculated using the following formula:

$$\text{Diff Current} = IL1\text{Four} + IL2\text{Four} + IL3\text{Four} + IN\text{Four}$$

The restraint current is calculated using the following formula:

$$\text{Bias Current} = \text{MAX}(IL1\text{Four}, IL2\text{Four}, IL3\text{Four}, IN\text{Four})$$

Based on these values, the zero sequence differential protection characteristics are shown in *Figure 1-6*.

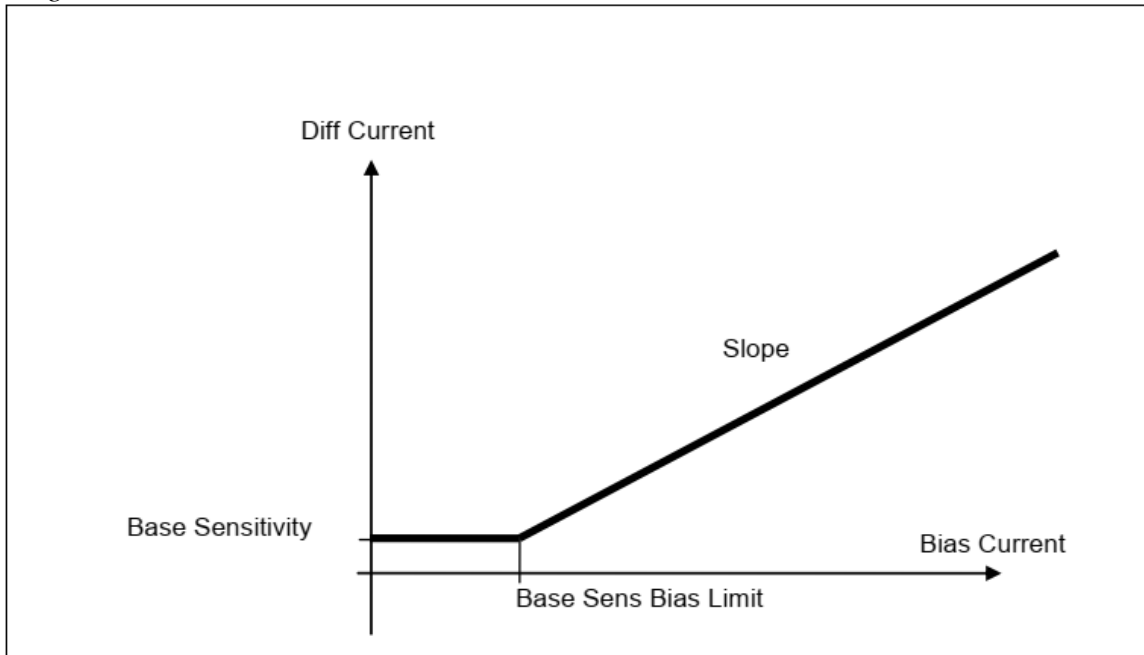

Figure 1-6 The zero sequence differential protection characteristics

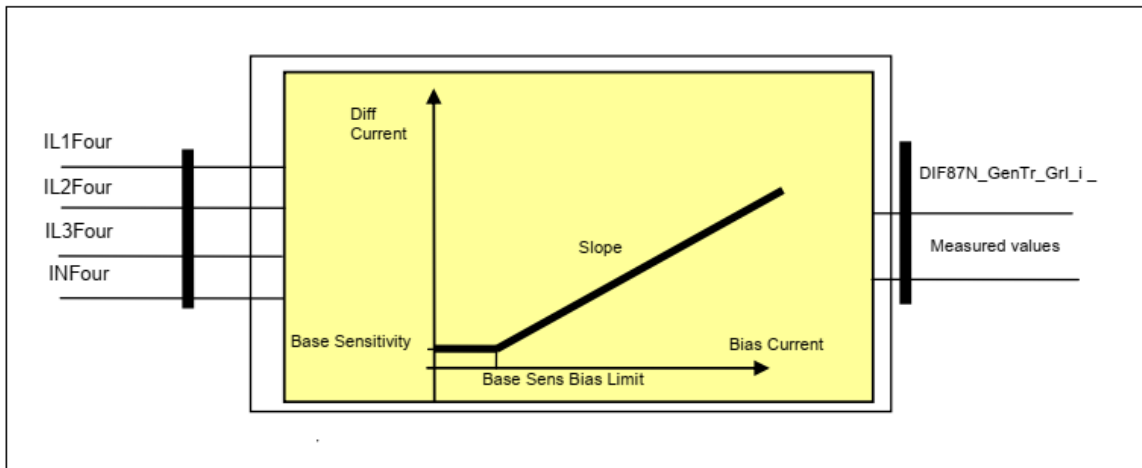

Figure 1-7 Principal scheme of the zero sequence differential protection

The **measured values** of the restricted earth-fault protection function are listed in Table 1-3.

Measured value	Title	Dim.	Explanation
DIF87N_Id_OLM_	Diff Current	In %	The calculated differential current
DIF87N_Bias_OLM_	Bias Current	In %	The calculated restraint current

Table 1-3 The measured analogue values of the zero sequence differential protection characteristics

The **binary output status signal** of the restricted earth-fault protection characteristics is shown in Table 1-4.

Binary output signals	Signal title	Explanation
DIF87N_GenTr_GrI_i	General Trip_i	Internal general trip signal of the differential characteristics

Table 1-4 The binary output status signals of the zero sequence differential protection characteristics

The parameters of the restricted earth-fault protection characteristics are explained in the following tables.

The integer parameters of the restricted earth-fault protection characteristics are listed in Table 1-5.

Parameter name	Title	Unit	Min	Max	Step	Default
Base sensitivity:						
DIF87N_f1_IPar_	Base Sensitivity	%*	10	50	1	30
Slope of the second section of the characteristics:						
DIF87N_f2_IPar_	Slope	%**	50	100	1	70
Break point of the characteristic line:						
DIF87N_f2Brk_IPar_	Base Sens Bias Limit	%*	100	200	1	125

(* % related to the magnitude-compensated current (see Table 1-1)

** % related to the bias current)

Table 1-5 The integer parameters of the zero sequence differential protection characteristics

The binary input signal serves to increase the base sensitivity by 4 times. **The conditions of increasing are defined by the user, applying the graphic equation editor.**

Binary input signal	Explanation
DIF87N_UnSens_GrO_	Output status of a graphic equation defined by the user to increase the base sensitivity by 4 times

Table 1-6 The binary input signal of the zero sequence differential protection characteristics

2.1.37.6. The decision logic (Decision logic)

The decision logic module combines the status signals, binary and enumerated parameters to generate the trip command of the function.

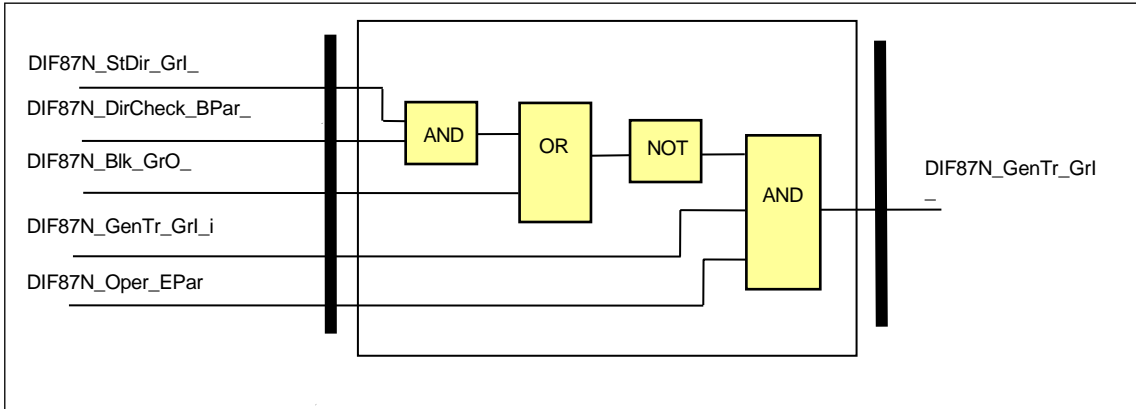

Figure 1-8 The logic scheme of the restricted earth-fault protection function

Binary input signals	Signal title	Explanation
DIF87N_GenTr_Grl_i	General Trip_i	Internal general trip signal of the differential characteristics
DIF87N_StDir_Grl_	Dir.element Start	Directional blocking signal restricted earth-fault protection function

Table 1-7 The binary input status signals of the zero sequence differential protection characteristics

The restricted earth-fault protection function has a binary input signal, which serves the purpose of disabling the function. **The conditions of disabling are defined by the user applying the graphic equation editor.**

Binary input signal	Explanation
DIF87N_Blk_GrO	Output status of a graphic equation defined by the user to disable the restricted earth-fault protection function.

Table 1-8 The binary input signal of the restricted earth-fault protection function

The binary output signals of the restricted earth-fault protection function are listed in Table 1-9.

Binary output signals	Signal title	Explanation
DIF87N_GenTr_Grl_	General Trip	General trip signal of the zero sequence differential protection characteristics
DIF87N_StDir_Grl_	Dir.element Start	Directional blocking signal of the restricted earth-fault protection function

Table 1-9 The binary output status signals of the zero sequence differential protection characteristics

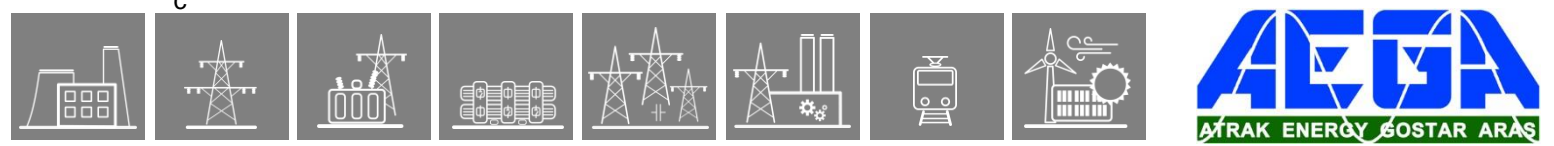

The enumerated parameter of the restricted earth-fault protection function is shown in Table 1-10:

Parameter name	Title	Selection range	Default
Parameter to enable the zero sequence differential protection function:			
DIF87N_Oper_EPar_	Operation	Off, On	On

Table 1-10 The enumerated parameters of the restricted earth-fault protection function

The Boolean parameter of the restricted earth-fault protection function is shown in Table 1-11:

Parameter name	Title	Default	Explanation
DIF87N_DirCheck_BPar_	Directional check	True	Enabling the directional checking of the measured and calculated zero sequence currents

Table 1-11 The Boolean parameters of the restricted earth-fault protection function

The restricted earth-fault protection function generates a trip signal if the differential current as the function of the bias current is above the differential characteristic lines and the function is not blocked and the operation of the function is enabled by parameter setting.

Blocking can be caused by the directional decision if it is enabled by parameter setting and the angle of the currents is in the blocking area or the user has composed a blocking graphic equation, and the conditions result a TRUE value for the blocking.

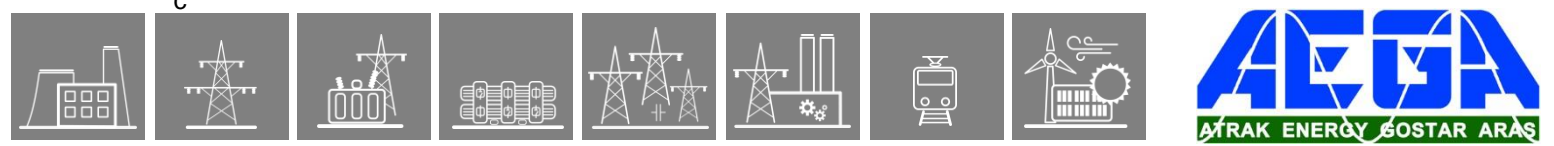

The integer parameters of the restricted earth-fault protection function are listed in Table 1-16.

Parameter name	Title	Unit	Min	Max	Step	Default
Parameters for the current magnitude compensation:						
DIF87N_TRPri_IPar_	TR Primary Comp	%	20	500	1	100
DIF87N_TRNeut_IPar_	TR Neutral	%	100	1000	1	500
Base sensitivity:						
DIF87N_f1_IPar_	Base Sensitivity	%	10	50	1	30
Slope of the second section of the characteristics:						
DIF87N_f2_IPar_	Slope	%	50	100	1	70
Break point of the characteristic line:						
DIF87N_f2Brk_IPar_	Base Sens Bias Limit	%	100	200	1	125

Table 1-16 The integer parameters of the restricted earth-fault protection function

Floating-point parameters

The restricted earth-fault protection function has no floating-point parameters.

Timer parameters

The restricted earth-fault protection function has no timers.

2.1.37.7.4. The binary input status signals

The restricted earth-fault protection function has a binary input signal, which serves the purpose of disabling the function. **The conditions of disabling are defined by the user, applying the graphic equation editor.**

The other binary input signal serves to increase the base sensitivity by 4 times. **The conditions of increasing the base sensitivity are defined by the user, applying the graphic equation editor.**

Binary input signal	Explanation
DIF87N_Blk_GrO	Output status of a graphic equation defined by the user to disable the restricted earth-fault protection function.
DIF87N_UnSens_GrO_	Output status of a graphic equation defined by the user to increase the base sensitivity by 4 times

Table 1-17 The binary input signal of the restricted earth-fault protection function

2.1.37.7.5. Binary output status signals

The **binary output status signals** of the restricted earth-fault protection function are listed in Table 1-18.

Binary output signals	Signal title	Explanation
DIF87N_GenTr_GrI_	General Trip	General trip signal of the restricted earth-fault protection function

Table 1-18 The binary output status signals of the restricted earth-fault protection function

2.1.37.7.6. The function block

The function block of the restricted earth fault protection function is shown in Figure 1-9. This block shows all binary input and output status signals that are applicable in the graphic equation editor.

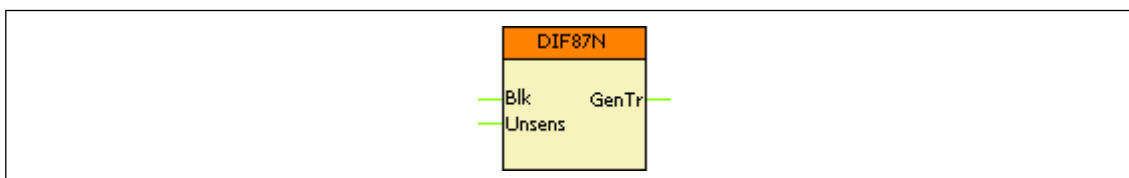

Figure 1-9 The function block of the restricted earth-fault protection function

2.1.37.9. Example for the application

For the application example consider an autotransformer equipped with tertiary, according to [Figure 1-1](#). The coils for the primary and secondary sides are auto-connected with solidly grounded neutral. The tertiary coils are delta connected, and applied also for power transmission.

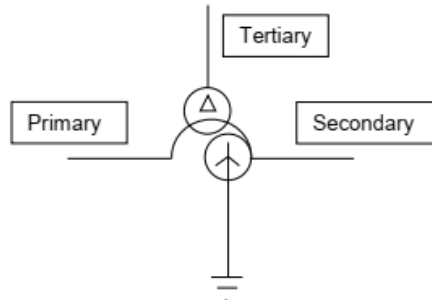

Figure 1-1 Autotransformer application

Example transformer data for the application:

Rated voltages: 220 kV / 132 kV / 11 kV
 Rated power: 100 MVA / 100 MVA / 30 MVA
 Calculated rated currents: 262 A / 437 A / 1575 A (5249 A)

NOTE: for the tertiary coil two currents are calculated, one is based on the coil rated power; this is 1575 A and one for the highest reference power (5249 A). This higher value is needed for balancing the differential protection function.

Current transformers installed for the application are shown in [Figure 1-2](#). The P1 points are arranged towards the transformer, except the CT in the grounding. For this CT the P2 point is toward the transformer.

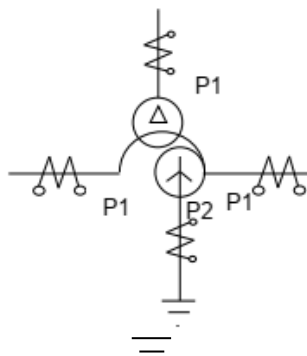

Figure 1-2 Current transformers, assigned to the differential protection and restricted earth-fault protection functions

Current transformer data:

Primary side 300 A / 1 A
 Secondary side 500 A / 1 A
 Tertiary side 2000 A / 1 A
 Grounding 300 A / 1 A

Suppose that the transformer is to be protected by differential protection and restricted earth-fault protection.

The phase differential protection involves the primary, secondary and tertiary windings, for this function the current measured by the CT in the grounding is not applied. The zero sequence current is eliminated numerically using matrix transformation within the differential protection function. See *Figure 1-3*.

The restricted earth-fault protection is applied for the galvanic connected windings. This means the auto-connected coils for the primary and secondary sides. The tertiary side is excluded from the protected zone. See *Figure 1-3*.

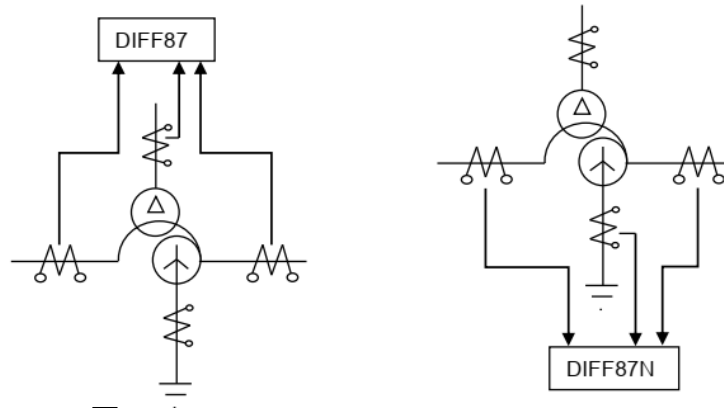

Figure 1-3 Differential protection and restricted restricted earth-fault protection application

The restricted earth-fault protection considers the coils as a node, bordered by current transformers: the three CT-s of the high voltage primary side, three CT-s of the secondary side and the CT in the grounding. Here the Kirchoff's node-law is to be satisfied: the sum of these seven currents must result zero. In other cases, due to internal fault, a TRIP command is to be generated for the circuit breakers.

If in theory the summation is performed in three steps: first the sum of three primary side currents is calculated, resulting the residual component at the primary side, then the sum of the three secondary currents is calculated, resulting the residual component at the secondary side, finally these calculated residual currents and the residual current measured in the grounding CT is added. As it can be seen, the restricted earth-fault protection is basically a zero sequence differential protection for the galvanic connected coils, as a node.

For the realization of the differential protection and jointly the restricted earth-fault protection function, a Protecta made EuroProt+ device configuration is applied. This device realizes – among other protection, supervision and monitoring functions – also these functions.

The required connection diagram is shown in *Figure 1-4*. The device contains three current input modules in positions “R”, “S” and “T”. Each current input module contains four CT inputs. The module in “T” is reserved for the primary three phase currents, and the fourth channel is the input for the CT in the grounding.

The module in “S” is reserved for the secondary three phase currents, and the fourth channel is not applied. Similarly, the module in “R” is reserved for the tertiary three phase currents, and the fourth channel is not applied.

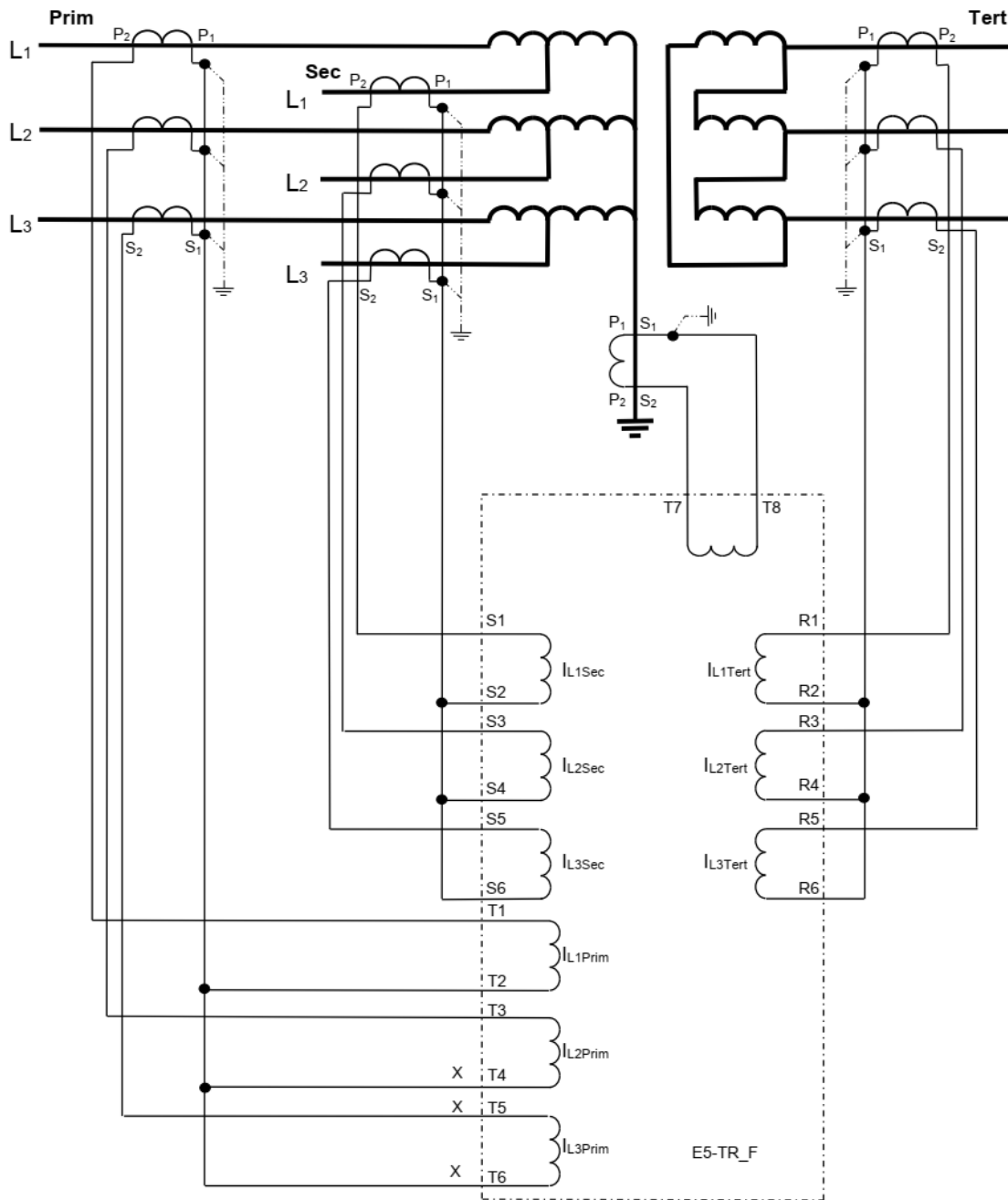
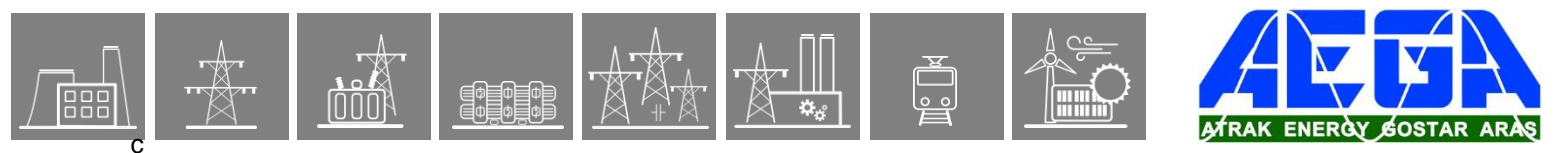

Figure 1-4 EuroProt+ connection diagram for differential protection and restricted earth-fault protection application

NOTE: In this diagram, as default, all CT P1 points are towards the protected object. Due to the reverse connection of the CT in the grounding, applied in the example, this direction is reverted by parameter setting.



In all three sides of the transformer, connect the CT in Y, with the neutral point at the transformer side, according to

Figure 1-4. The vector group compensation, required in Primary/Tertiary and in Secondary/Tertiary relationship is performed numerically within the differential protection function, together with magnitude compensation. Similarly the required zero sequence elimination is solved numerically. No interposing current transformers are required.

2.1.37.9.1. Setting the CT input function blocks

In the EuroProt+ devices the CT inputs are assigned to CT function blocks. They need parameter setting and also displaying functions are assigned to them. *Figure 2-1* shows the parameter screen, when there is Internet connection with the device. For details about this communication see the Protecta document “**Remote user interface description**” available in Protecta WEB site www.protecta.hu.

NOTE: the parameters can be set also using the local LCD touch-screen of the device, if no internet connection is available. For details about this communication see the Protecta document “**LCD touchscreen interface description**” available in Protecta WEB site www.protecta.hu.

The parameters of the current input function are explained in the following tables.

Enumerated parameters

Parameter name	Title	Selection range	Default
Rated secondary current of the first three input channels. 1A or 5A is selected by parameter setting, no hardware modification is needed.			
CT4_Ch13Nom_EPar_	Rated Secondary I1-3	1A,5A	1A
Rated secondary current of the fourth input channel. 1A or 5A (0.2A, 1A) is selected by parameter setting, no hardware modification is needed.			
CT4_Ch4Nom_EPar_	Rated Secondary I4	1A,5A (0.2A, 1A)	1A
Definition of the positive direction of the first three currents, given by location of the secondary star connection point			
CT4_Ch13Dir_EPar_	Starpoint I1-3	Line,Bus	Line
Definition of the positive direction of the fourth current, given as normal or inverted			
CT4_Ch4Dir_EPar_	Direction I4	Normal,Inverted	Normal

Table 2-1 The enumerated parameters of the current input function

Floating point parameters

Parameter name	Title	Dim.	Min	Max	Default
Rated primary current of channel1-3					
CT4_Pr113_FPar_	Rated Primary I1-3	A	100	4000	1000
Rated primary current of channel4					
CT4_Pr114_FPar_	Rated Primary I4	A	100	4000	1000

Table 2-2 The floating point parameters of the current input function

NOTE: The rated primary current of the channels is not needed for the current input function block itself. These values are passed on to the subsequent function blocks.

[-] CT4 module Prim.

	Device value (Default_set_1)	New value	
Rated Secondary I1-3	<input type="text" value="1A"/>	<input type="text" value="1A"/> <input type="button" value="v"/>	
Rated Secondary I4	<input type="text" value="1A"/>	<input type="text" value="1A"/> <input type="button" value="v"/>	
Starpoint I1-3	<input type="text" value="Line"/>	<input type="text" value="Line"/> <input type="button" value="v"/>	
Direction I4	<input type="text" value="Inverted"/>	<input type="text" value="Inverted"/> <input type="button" value="v"/>	
Rated Primary I1-3	<input type="text" value="300"/>	<input type="text" value="300"/>	A
Rated Primary I4	<input type="text" value="300"/>	<input type="text" value="300"/>	A

[-] CT4 module Sec.

	Device value (Default_set_1)	New value	
Rated Secondary I1-3	<input type="text" value="1A"/>	<input type="text" value="1A"/> <input type="button" value="v"/>	
Rated Secondary I4	<input type="text" value="1A"/>	<input type="text" value="1A"/> <input type="button" value="v"/>	
Starpoint I1-3	<input type="text" value="Line"/>	<input type="text" value="Line"/> <input type="button" value="v"/>	
Direction I4	<input type="text" value="Normal"/>	<input type="text" value="Normal"/> <input type="button" value="v"/>	
Rated Primary I1-3	<input type="text" value="500"/>	<input type="text" value="500"/>	A
Rated Primary I4	<input type="text" value="300"/>	<input type="text" value="300"/>	A

[-] CT4 module Tert.

	Device value (Default_set_1)	New value	
Rated Secondary I1-3	<input type="text" value="1A"/>	<input type="text" value="1A"/> <input type="button" value="v"/>	
Rated Secondary I4	<input type="text" value="1A"/>	<input type="text" value="1A"/> <input type="button" value="v"/>	
Starpoint I1-3	<input type="text" value="Line"/>	<input type="text" value="Line"/> <input type="button" value="v"/>	
Direction I4	<input type="text" value="Normal"/>	<input type="text" value="Normal"/> <input type="button" value="v"/>	
Rated Primary I1-3	<input type="text" value="2000"/>	<input type="text" value="2000"/>	A
Rated Primary I4	<input type="text" value="300"/>	<input type="text" value="300"/>	A

Figure 2-1 EuroProt+ parameter screen for the CT input modules

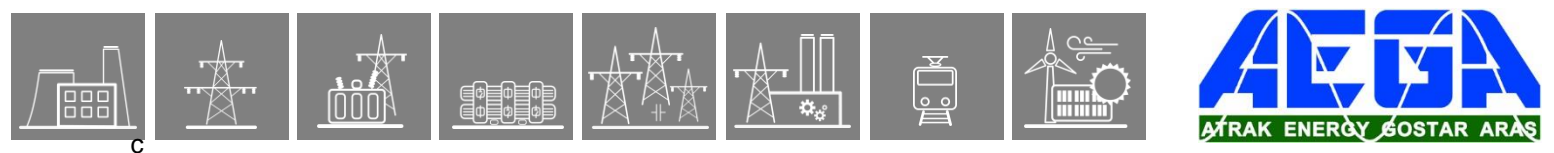

Using the information given in this example above, the following setting values are assigned:

Primary side and grounding CT:

Rated Secondary I1-3	1A	Selected, according to the CT applied at the primary side.
Rated Secondary I4	1A	Selected, according to the CT applied in the grounding.
Starpoint I1-3	Line	“Line” in this case means “Toward protected object = Transformer”
Direction I4	Inverted	In this application all P1 points of the CT-s are on the transformer side, except the CT in the grounding, which has P2 point at the transformer side. This is the reason why the positive direction is “Inverted” to fulfill the Kirchhoff’s node law.
Rated Primary I1-3	300	Setting, according to the CT applied at the primary side. This parameter is used for scaling the displayed values only
Rated Primary I4	300	Setting, according to the CT applied in the grounding. This parameter is used for scaling the displayed values only

Secondary side:

Rated Secondary I1-3	1A	Selected, according to the CT applied at the secondary side.
Rated Secondary I4		Not applied, the value is not considered.
Starpoint I1-3	Line	“Line” in this case means “Toward protected object = Transformer”
Direction I4		Not applied, the value is not considered.
Rated Primary I1-3	500	Setting, according to the CT applied at the secondary side. This parameter is used for scaling the displayed values only
Rated Primary I4		Not applied, the value is not considered.

Tertiary side:

Rated Secondary I1-3	1A	Selected, according to the CT applied at the tertiary side.
Rated Secondary I4		Not applied, the value is not considered.
Starpoint I1-3	Line	“Line” in this case means “Toward protected object = Transformer”
Direction I4		Not applied, the value is not considered.
Rated Primary I1-3	2000	Setting, according to the CT applied at the tertiary side. This parameter is used for scaling the displayed values only
Rated Primary I4		Not applied, the value is not considered.

Table 2-3 Summary of the CT parameter setting

2.1.37.10. Setting the differential protection function

The parameters of the differential protection function are explained in the following tables.

Enumerated parameters for the differential protection function:

Parameter name	Title	Selection range	Default
Parameter to enable the differential protection function:			
DIF87_Op_EPar_	Operation	Off, On	On
Parameter to select connection group of the transformer coils in primary-secondary relation:			
DIF87_VGrSec_EPar_	Pri-Sec VGroup*	Dy1,Dy5,Dy7,Dy11,Dd0,Dd6,Dz0,Dz2,Dz4,Dz6,Dz8,Dz10,Yy0,Yy6,Yd1,Yd5,Yd7,Yd11,Yz1,Yz5,Yz7,Yz11	Dd0
Parameter to select connection group of the transformer coils in primary-tertiary relation:			
DIF87_VGrTer_EPar_	Pri-Ter VGroup*	Dy1,Dy5,Dy7,Dy11,Dd0,Dd6,Dz0,Dz2,Dz4,Dz6,Dz8,Dz10,Yy0,Yy6,Yd1,Yd5,Yd7,Yd11,Yz1,Yz5,Yz7,Yz11	Dd0

Table 3-1 The enumerated parameters of the differential protection function

* If the connection of the primary winding in primary-secondary and primary tertiary relation is selected in contradiction then the protection function is automatically disabled, and the function generates a warning signal.

Boolean parameter for the differential protection function:

Parameter name	Title	Default	Explanation
DIF87_0Seq_BPar_	Zero Seq Elimination	True	

Table 3-2 The Boolean parameter of the differential protection function

Integer parameters

Parameter name	Title	Unit	Min	Max	Step	Default
Parameters for the current magnitude compensation:						
DIF87_TRPr_IPar_	TR Primary Comp	%	20	500	1	100
DIF87_TRSec_IPar_	TR Secondary Comp	%	20	500	1	100
DIF87_TRTer_IPar_	TR Tertiary Comp	%	20	200	1	100
Parameter of the second harmonic restraint:						
DIF87_2HRat_IPar_	2nd Harm Ratio	%	5	50	1	15
Parameter of the fifth harmonic restraint:						
DIF87_5HRat_IPar_	5th Harm Ratio	%	5	50	1	25
Parameters of the percentage characteristic curve:						
Base sensitivity:						
DIF87_f1_IPar_	Base Sensitivity	%	10	50	1	20
Slope of the second section of the characteristics:						
DIF87_f2_IPar_	1st Slope	%	10	50	1	20
Bias limit of the first slope:						
DIF87_f3_IPar_	1st Slope Bias Limit	%	200	2000	1	200
Unrestrained differential protection current level:						
DIF87_HCurr_IPar_	UnRst Diff Current	%	800	2500	1	800

Table 3-3 The integer parameters of the differential protection function

[-] Differential 3w		
	Device value (Default_set_1)	New value
Operation	On	On <input type="button" value="v"/>
Pri-Sec VGroup	Yy0	Yy0 <input type="button" value="v"/>
Pri-Ter VGroup	Yd11	Yd11 <input type="button" value="v"/>
ZeroSeq Elimination	<input type="checkbox"/>	<input type="checkbox"/>
TR Primary Comp	87	87 <input type="button" value="v"/> %
TR Secondary Comp	87	87 <input type="button" value="v"/> %
TR Tertial Comp	262	262 <input type="button" value="v"/> %
2nd Harm Ratio	15	15 <input type="button" value="v"/> %
5th Harm Ratio	25	25 <input type="button" value="v"/> %
Base Sensitivity	50	50 <input type="button" value="v"/> %
1st Slope	50	50 <input type="button" value="v"/> %
1st Slope Bias Limit	400	400 <input type="button" value="v"/> %
UnRst Diff Current	800	800 <input type="button" value="v"/> %

Figure 3-1 EuroProt+ parameter screen for the differential protection function

These parameters need basic considerations some of them need also calculation. This is explained in the table below:

Operation	On	Set this parameter to “On” for enabling the function. NOTE: In tests, when other protection functions are tested. Switch this parameter to “Off” to prevent false test results
Pri-Sec VGroup	Yy0	This setting is selected according to the protected object. For autotransformers select always Yy0. NOTE: see explanation in paragraph 3.1.
Pri-Ter VGroup	Yd11	This setting is selected according to the protected object. (Example) NOTE: see explanation in paragraph 3.1
Zero Seq Elimination	False	Not checked. This parameter is needed only if there is isolated (Not grounded) side of the transformer and there is and additional neutral grounding transformer within the protected zone. As this additional neutral grounding transformer is not supposed to be present, the checkbox can remain unchecked. This is described in paragraph
TR Primary Comp	87	This value needs calculation. This is described in paragraph 3.2
TR Secondary Comp	87	This value needs calculation. This is described in paragraph 3.2
TR Tertiary Comp	262	This value needs calculation. This is described in paragraph 3.2
2nd Harm Ratio	15	This value needs some considerations. These are described in paragraph 3.3
5nd Harm Ratio	25	This value needs some considerations. These are described in paragraph 3.3
Base Sensitivity	50	Parameter for the differential characteristic. This value needs some considerations. These are described in paragraph 3.4
1st Slope	50	Parameter for the differential characteristic. This value needs some considerations. These are described in paragraph 3.4
1st Slope Bias Limit	400	Parameter for the differential characteristic. This value needs some considerations. These are described in paragraph 3.4
UnRst Diff Current	800	Parameter for the differential characteristic. This value needs some considerations. These are described in paragraph 3.4

Table 3-4 Summary of the differential protection parameter setting

2.1.37.10.1. Vector shift compensation

The Protecta EuroProt+ configurations perform numerical vector shift compensation. The secondary wires of the current transformers are connected in Y, and the three phase currents secondary values are input directly into the current inputs of the device. No interposing CT-s are required.

The principle of the vector shift compensation is the numerical realization of the old principle: on Y side of the transformer apply delta connected secondary, on delta side of the transformer apply Y connected secondary. The advantage of this method is that the zero sequence current elimination is “automatic”.

The numerical solution is matrix multiplication: on Y side a phase shifting matrix is applied, e.g. for Yd11 transformation it is:

$$\begin{bmatrix} I_{1Rshift} \\ I_{1Sshift} \\ I_{1Tshift} \end{bmatrix} = \frac{1}{\sqrt{3}} \begin{bmatrix} 1 & -1 & 0 \\ 0 & 1 & -1 \\ -1 & 0 & 1 \end{bmatrix} \begin{bmatrix} I_{1r} \\ I_{1s} \\ I_{1t} \end{bmatrix}$$

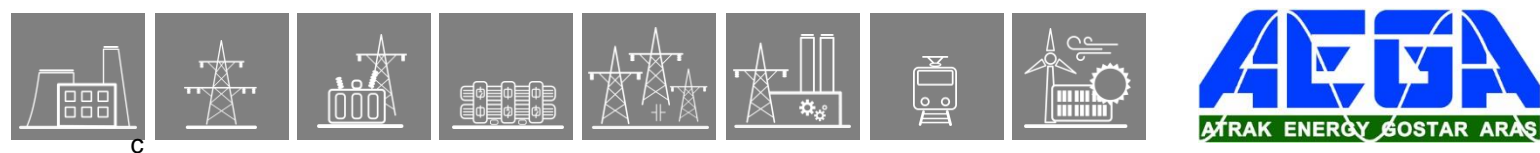

2.1.37.10.2. Calculation of the amplitude compensation for the differential protection function

The basic principle is that in case of power transfer at rated current the currents to be compared should be the same, 100%. This means that in case of any external faults there will be no current difference, the differential function is balanced and stable.

For a two winding transformer, usually the rated current of the transformer is considered to be the base current, considered to be 100%. The ratio of the secondary and primary rated currents is the turn's ratio of the transformer.

For the setting calculation, calculate the ratio of the transformer rated current and the CT rated primary current. These values expressed in % are the parameter values to be set for parameters „TR Primary Comp” and “TR Secondary Comp”.

For a three winding transformer in the example the rated power of the winding is not the same (100MVA, 100 MVA and 30 MVA), consequently the ratio of rated currents for the windings do not match the turn's ratio of the coils. In this case the usual procedure is to consider the rated current of the primary side, and transform this current both for the secondary and to the tertiary side. These calculated currents should be related to the rated currents of the CT-s. These values expressed in % are the parameter values to be set for parameters „TR Primary Comp”, “TR Secondary Comp” and “TR Tertiary Comp”.

In the example:

The rated primary current is 262 A, see the transformer data above. This is the reference current.

This current is transformed to the secondary is 437 A.

This current is transformed to the tertiary is 5249 A. (Here the rated current would be 1575 A, this value is not considered!) The calculation of the setting values is as follows

$$\begin{aligned} \text{„TR Primary Comp"} &= 100 * 262 \text{ A} / 300 \text{ A} = 87\% \\ \text{„TR Secondary Comp"} &= 100 * 437 \text{ A} / 500 \text{ A} = 87\% \\ \text{„TR Tertiary Comp"} &= 100 * 5249 \text{ A} / 2000 \text{ A} = 262\% \end{aligned}$$

Using this setting, the reference current on the secondary side is displayed by the differential protection function as 100%.

2.1.37.10.3. Considerations, related to the harmonic restraint

When a transformer is energized then due to the asymmetric saturation of the iron core a high “inrush current” can flow from one side into the transformer. This is a pure differential current. To prevent unwanted operation of the differential protection the special waveform of the inrush current is identified. The principle is the detection of the second harmonic content, which is present in the inrush current, but its value can be neglected in any fault current. For the differential current, the second harmonic component in the evaluation is related to the value of the base harmonic. This is the parameter „2nd Harm Ratio”. If this ration gets higher due to inrush current, the trip command is blocked.

When a transformer is overexcited then the iron core is saturated symmetrically, resulting high current peaks, distorting both the positive and the negative sinusoidal current shape. In this current shape the fifth harmonic is characteristic. To prevent mal-operation, this component of the differential current is analyzed and compared to the base harmonic. If the ratio is high, then the differential current is caused by the over-excitation, the trip command is blocked. If however the fifth harmonic content is low, then the high differential current, which is a fault current, results trip command. The ratio is the parameter „5th Harm Ratio”.

If no results of detailed harmonic analysis are available, apply the factory setting, which can be corrected later. The proposed setting values are:

$$\text{„2nd Harm Ratio”} = 15 \%$$

and

$$\text{„5th Harm Ratio”} = 25 \%$$

2.1.37.10.4. Considerations, related to the differential characteristic for the differential protection function

The differential characteristic is shown in *Figure 3-2*. If the calculated (I_{diff} , I_{bias}) operating point is above the characteristic, then the differential protection operates.

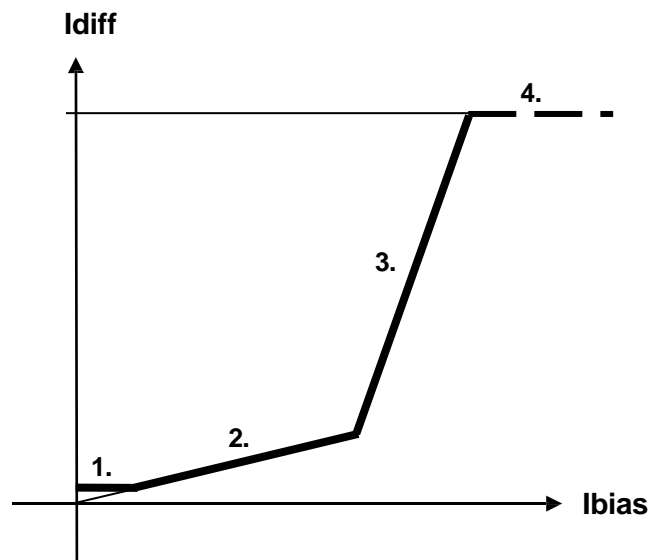
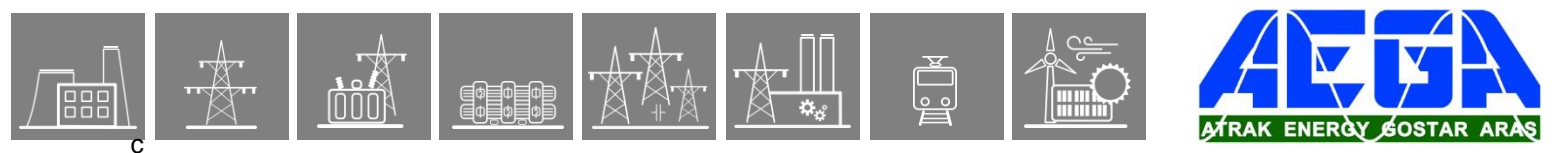

Figure 3-2 The differential characteristic

This characteristic has four sections; each of them is a straight line. The parameters define the position of these lines on the I_{diff} - I_{bias} plane.

The first parameter is “Base Sensitivity”, it defines the minimum differential current for the operation. Its role is to prevent mal-operation in case of current noises and measuring errors for small currents. In this example the selected setting value is the less sensitive selection:



„Base Sensitivity” = 50 %,

This value can be tested easily: inject three phase symmetrical currents from one side only and increase its value. The operation is expected if this current gets above 50% of the reference current. (In this example it is $0.5 \cdot 0.87A$. NOTE: for asymmetrical fault current this value changes due to the matrix transformation.)

The second section of the characteristic is a line through the origin of the I_{diff} - I_{bias} plane. The slope of this line serves to compensate the not correct matching of the CT-s, e.g. due to the different tap-changer positions and the CT errors. Due to these causes the error current increases if the current flowing through the transformer increases. The parameter is “1st Slope”. The mathematical expression of the second section of the characteristic is:

$$I_{diff} = \frac{1stSlope}{100} * I_{bias}$$

The steps for getting the parameter value are as follows:

- Calculate the error in percent, due to not correct matching (To be calculated for all three voltage levels):

$$x\% = \left(1 - \left| \frac{I1 \cdot required_matching}{I1 \cdot matching} \right| \right) * 100$$

- The unbalance of the differential protection at top or bottom position of the tap changer in percent, related to the value of 0 position ($r_{max}\%$):

$$x\% = |r_{max}\%|$$

Select the biggest value of the calculated x% values above. The setting value is advised to be above this value.

Example: suppose the voltage control range to be +18%/–12 %, and the reference position for current balancing is the 0 position, then the parameter value with 1,5x safety is:

$$\text{„1st Slope”} = 1,5 \cdot 18 = 27 \rightarrow 30 \%$$

Another choice for calculation is the selection the mid-position of the tap-changer. This is in this example as follows: The full position range is $18 + 12 = 30 \%$, The half value is 15% , accordingly the mid-position is $+3 \%$. With his the voltage ratio of the transformer to be considered is to be increased by $118 / 115$, and the balancing of the current is to be determined for this voltage. In this case only $\pm 15 \%$ tap position range can be considered, and the value of this parameter is decreased to:

$$\text{„1st Slope”} = 1,5 \cdot 15 = 22,5 \rightarrow 25 \%$$

The slope of the third section of the characteristic is higher. This is to compensate the increased CT error, due to the CT saturation at higher currents. This higher sloe is a factory setting: 200%. The parameter “1st Slope Bias Limit” defines the intersection point of section 2 and 3.

This parameter value is influenced by the highest fault current in the protected object and the applied current transformer saturation point related to the rated value. If the current transformer is less over-dimensioned then select the parameter vale for “1st Slope Bias Limit” low. The usual consideration is: for relatively high currents select 200 %, for low fault currents select 1000 %.

The fourth section of the characteristic is the unrestrained section. The related parameter is “UnRst Diff Current”. This parameter serves unrestrained fast operation if the high magnitude of the fault current indicates internal fault. The calculation determines the maximal external fault current, and the setting value should be above this current.

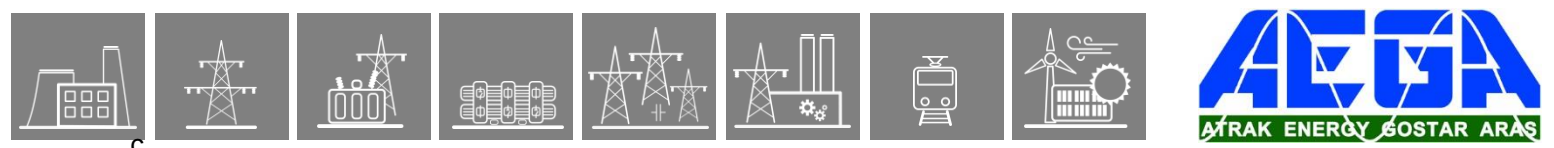

2.1.37.10.5. Considerations for zero sequence elimination

In solidly grounded high voltage networks, in case of external earth faults, the Y-delta transformers revert zero sequence current, which is present on the Y side only. No zero sequence current can flow on the delta side. When comparing the currents in the differential protection, this could cause unwanted operation.

The differential protection function in the Protecta EuroProt+ devices eliminates the Y side zero sequence current by matrix transformation (simulating the old type delta connected CT secondary behavior). This elimination is automatic, no additional solution is needed.

In several cases, however, there is additional neutral grounding transformer on the delta side for the transformer within the protected zone. Between the neutral point of this additional transformer an arc suppression Petersen coil, or a grounding resistor is connected. The Petersen coil minimizes the earth-fault current to some Amperes, the resistor limits the earth-fault current to 100 A (in some cases to 200 A).

If the neutral grounding transformer is not in the protected zone, it is outside the current transformers, then set:

„ZeroSeq Elimination” = „False” (Not checked)

In some cases, however, the neutral grounding transformer is closely connected to the main transformer's delta side terminals, it is in the protected zone. The advantage of this arrangement is that the energizing the transformer immediately solves the neutral grounding problems.

In case of external earth-fault the zero sequence current of the neutral grounding transformer is detected by the delta side current transformers. The zero sequence elimination is needed. In this case set

„ZeroSeq Elimination” = „True” (Checked)

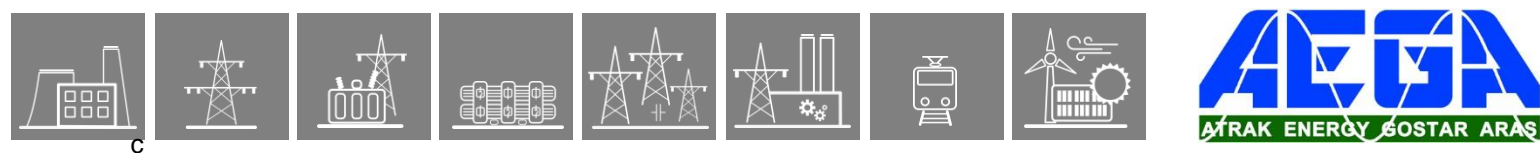

2.1.37.11. Setting the restricted earth-fault protection function

The restricted earth-fault protection function is basically a zero sequence (residual) differential protection (DIF87N), applied for the galvanic interconnected coils.

The parameters of the restricted earth-fault protection function are explained in the following tables.

Enumerated parameter for the restricted earth-fault protection function:

Parameter name	Title	Selection range	Default
Parameter to enable the differential protection function:			
DIF87N_Op_EPar_	Operation	Off, On	On

Table 4-1 The enumerated parameter of the restricted earth-fault protection function

Boolean parameter for the differential protection function:

Parameter name	Title	Default	Explanation
DIF87N_DirCheck_BPar_	Directional check	True	

Table 4-2 The Boolean parameter of the restricted earth-fault protection function

Integer parameters

Parameter name	Title	Unit	Min	Max	Step	Default
Parameters for the current magnitude compensation:						
DIF87N_TRPri_IPar_	TR Primary Comp	%	4	500	1	100
DIF87N_TRSec_IPar_	TR Secondary Comp	%	4	500	1	100
DIF87N_TRNeut_IPar_	TR Neutral Comp	%	4	1000	1	500
Parameters of the percentage characteristic curve:						
Base sensitivity:						
DIF87N_f1_IPar_	Base Sensitivity	%	10	50	1	20
Slope of the second section of the characteristics:						
DIF87N_f2_IPar_	Slope	%	50	100	1	70
Bias limit of the first slope:						
DIF87N_f2Brk_IPar_	Base Sensitivity Bias Limit	%	100	200	1	125

Table 4-3 The integer parameters of the restricted earth-fault protection function

[-] Restricted EF

	Device value (Default_set_1)	New value
Operation	On	On <input type="button" value="v"/>
Directional check	<input type="checkbox"/>	<input type="checkbox"/>
TR Primary Comp	15	15 %
TR Secondary Comp	9	9 %
TR Neutral Comp	15	15 %
Base Sensitivity	50	50 %
Slope	50	50 %
Base Sens Bias Limit	125	125 %

Figure 4-1 EuroProt+ parameter screen for the restricted earth-fault protection function

These parameters need basic considerations some of them need also calculation. This is explained in the table below:

Operation	On	Set this parameter to “On” for enabling the function. NOTE: In tests, when other protection functions are tested, switch this parameter to “Off” to prevent false test results
Directional check	False	Not checked. This parameter is needed to increase the security of the function in case of low level external faults. This is described in paragraph 4.3
TR Primary Comp	15	This value needs calculation. This is described in paragraph 4.1
TR Secondary Comp	9	This value needs calculation. This is described in paragraph 4.1
TR Neutral Comp	15	This value needs calculation. This is described in paragraph 4.1
Base Sensitivity	50	Parameter for the differential characteristic. This value needs some considerations. These are described in paragraph 4.2
1st Slope	50	Parameter for the differential characteristic. This value needs some considerations. These are described in paragraph 4.2
1st Slope Bias Limit	125	Parameter for the differential characteristic. This value needs some considerations. These are described in paragraph 4.2

Table 4-4 Summary of the CT parameter setting

2.1.37.11.1. Calculation of the amplitude compensation for the restricted earth-fault protection function

The basic principle is that in case of any external faults there will be no current difference, the zero sequence differential function is balanced and stable.

The setting of the restricted earth-fault protection function is independent of the setting of the differential protection function.

Here the same current is freely selected as the base current for the whole, galvanic connected coil system. The choice of the current is free. For more sensitive protection select a relatively low value. In the example the following value is selected:

$$I_{Base} = 44 \text{ A}$$

This is a primary value, which is transformed by the current transformers to the secondary side. For the setting, it is related to the rated primary currents of the current transformers:

- „TR Primary Comp”= $100 \cdot 44 \text{ A} / 300 \text{ A} = 15\%$
- „TR Secondary Comp”= $100 \cdot 44 \text{ A} / 500 \text{ A} = 9\%$
- „TR Neutral Comp” = $100 \cdot 44 \text{ A} / 300 \text{ A} = 15\%$

In the restricted earth-fault protection these values are used for amplitude matching the secondary currents

2.1.37.11.2. Considerations, related to the differential characteristic for the restricted earth-fault protection function

The differential characteristic is shown in *Figure 4-2*. If the calculated (I_{bias}, I_{diff}) operating point is above the characteristic, then the differential protection operates.

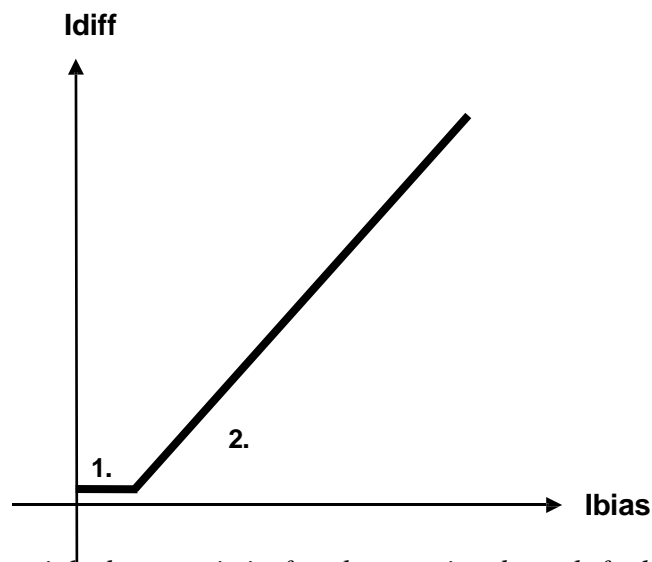

Figure 4-2 The differential characteristic for the restricted earth-fault protection function

This characteristic has two sections; each of them is a straight line. The parameters define the position of these lines on the I_{diff} - I_{bias} plane.

The parameters are expressed in percent, the basis is the “IBase” selected current. The first parameter is “Base Sensitivity”, it defines the minimum differential current for the operation. Its role is to prevent mal-operation in case of current noises and measuring errors for small currents. In this example the selected setting value is the less sensitive selection:

$$\text{„Base Sensitivity”} = 50 \%,$$

NOTE: The percent value is related to the “IBase” selected current. In the example the restricted earth-fault protection summarizes the secondary currents of seven current transformers. It is advised to avoid too sensitive setting, due to the accumulated errors on several CT-s. Similarly select not too low current for “IBase” base current for the reference and for the calculation.

This value can be tested easily: inject a single residual current e.g. into the grounding CT input and increase its value. The operation is expected if this current gets above 50% of the reference current. (In this example it is $0.5 \cdot 44A / 300A \cdot 1A = 73.3 \text{ mA}$.)

The slope of the second section of the characteristic intends to compensate the not correct matching of the CT-s, e.g. due to the CT errors. Consider that the error current increases if the zero sequence current flowing through the transformer increases. In the example the selected setting value is:

$$\text{„1st Slope”} = 50 \%,$$

NOTE: The percent value is related to the IBias current.

The third parameter defines the intersection point of the two characteristic lines. Do not select this point too high, because near to the intersection point it leaves too much area, where error currents can intersect the characteristic.

In the example the selected setting value is:

$$\text{„1st Slope Bias Limit”} = 125 \%.$$

NOTE: The percent value is related to the “IBase” selected current.

2.1.37.11.3. Considerations, related to the directional check

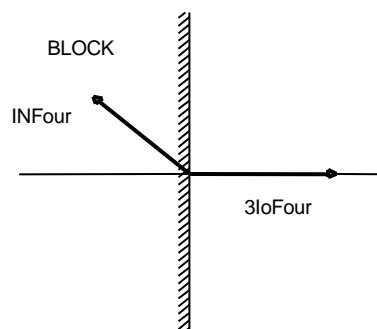
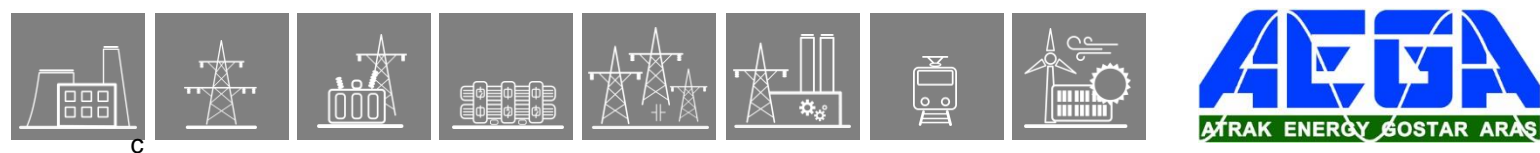

Figure 4-3 Principle of the directional check

In the directional check the vector position of the residual current measured in the grounding (IN_{Four}) and that of the vectorial sum of all other currents ($3Io_{Four}$) is compared.

Figure 4-3 shows a vector position which blocks the operation of the restricted earth fault protection, if the Boolean parameter “Directional check” is True (Checked). If the checkbox is not checked then the directionality is not considered. This parameter is needed to increase the security of the function in case of low level external faults



2.1.37.12. Testing instructions

2.1.37.12.1. Testing the differential protection

When testing a function, it is advised to disable all other functions to avoid trip commands generated by the other functions.

The applied test set supports the tests with 2*3 currents. With this test set the differential protection can be tested in three steps: Primary/Secondary, Primary/Tertiary and Secondary/Tertiary relationship. In all cases the currents of the not tested side is supposed to be zero.

This paragraph shows the tests in Pimary/Secondary relationship.

The basic parameters are documented by the test set, as it is shown in

Test Object - Differential Parameters

Protected Object:

Protected Object: Transformer
Vector Group: YY0D11

Winding/Leg Name:	Primary	Secondary	Tertiary
Voltage:	220,00 kV	132,00 kV	11,00 kV
Power:	100,00 MVA	100,00 MVA	30,00 MVA
Starpoint Grounding:	Yes	Yes	No
Delta-connected CT:	No	No	No

CT:

Winding/Leg Name:	Primary	Secondary	Tertiary
CT Current Prim:	300,00 A	500,00 A	2000,00 A
CT Current Sec:	1,00 A	1,00 A	1,00 A
CT Grounding:	tow. Prot. Obj.	tow. Prot. Obj.	tow. Prot. Obj.
Gnd CT Prim Current:	200,00 A	800,00 A	800,00 A
Gnd CT Sec Current:	1,00 A	1,00 A	1,00 A
Gnd CT Grounding:	n/a	n/a	n/a

Figure 5-1 Basic test parameters

The setting values of the function correspond to the values described above.

Please consider that the differential protection function is the cooperation of three “measuring elements”. Each measuring element gets the magnitude- and phase-compensated currents. NOTE that in case of asymmetric fault the input current values are modified due to the matrix phase-shift compensation as compared to the injected fault currents, if the fault is supposed to be on the Y side of the transformer.

In the characteristic tests please consider that the Idiff differential current in the differential protection function is the vectorial sum of all nine phase-compensated and magnitude compensated currents in three groups, related to the three “measuring elements”. The Ibias current is the sum of the absolute values of three currents in the measuring elements divided by 2.

The simplest test is a three phase injection test for testing the accuracy of the differential characteristic.

For asymmetric fault tests the expected characteristic is modified to cover the current modification of the vector shift compensation.

Test Results for Fault Location L2-L3 at Reference Side Primary

Ibias	Idiff Nominal	Idiff Actual	Dev (rel)	Dev (abs)	Check Test	State	Result
0,50 In	0,433 In	0,430 In	-0,72 %	-0,0031 In		Tested	Passed
1,00 In	0,495 In	0,498 In	0,54 %	0,0027 In		Tested	Passed
1,50 In	0,745 In	0,742 In	-0,40 %	-0,0030 In		Tested	Passed
2,00 In	0,995 In	0,991 In	-0,37 %	-0,0036 In		Tested	Passed
2,50 In	1,245 In	1,241 In	-0,34 %	-0,0043 In		Tested	Passed
3,00 In	1,495 In	1,490 In	-0,33 %	-0,0049 In		Tested	Passed
4,00 In	1,995 In	1,992 In	-0,16 %	-0,0031 In		Tested	Passed
5,00 In	2,495 In	2,491 In	-0,15 %	-0,0037 In		Tested	Passed
6,00 In	2,995 In	2,991 In	-0,15 %	-0,0044 In		Tested	Passed
7,00 In	3,600 In	3,586 In	-0,41 %	-0,0146 In		Tested	Passed
8,00 In	5,606 In	5,626 In	0,35 %	0,0197 In		Tested	Passed
9,00 In	6,930 In	6,903 In	-0,39 %	-0,0274 In		Tested	Passed
10,00 In	6,930 In	6,900 In	-0,43 %	-0,0298 In		Tested	Passed

Operating Characteristic Diagram

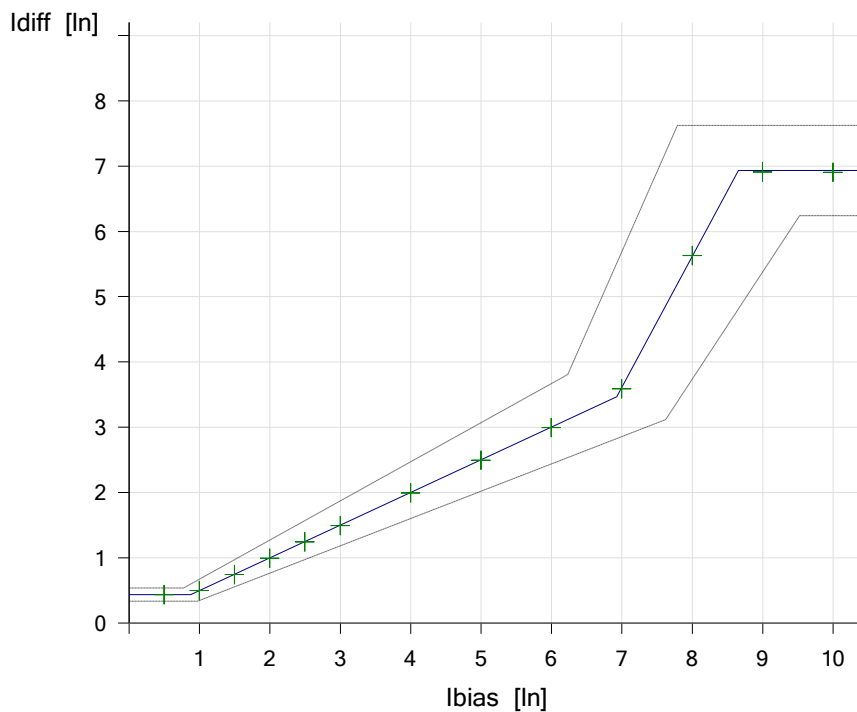

Figure 5-3 Result of double phase fault test, the fault is at the secondary side, supplied from the primary side

NOTE The matrix vector shift compensation decreases the compared current by SQRT3. Consequently the detected knee points of the characteristic are shifted to increased current values. (The setting values of the differential protection function are the same as those applied in three-phase fault test.)

Similarly, in case of single phase faults, the expected characteristic is modified. (The setting values of the differential protection function are the same as those applied in three-phase fault test.) This is shown in [Figure 5-4](#).

Operating Characteristic Diagram

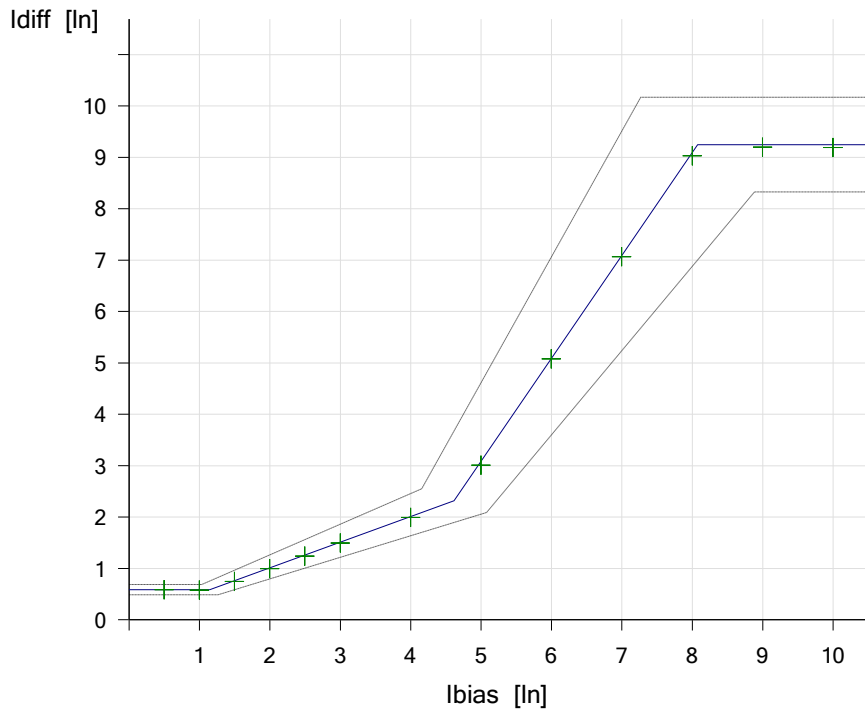
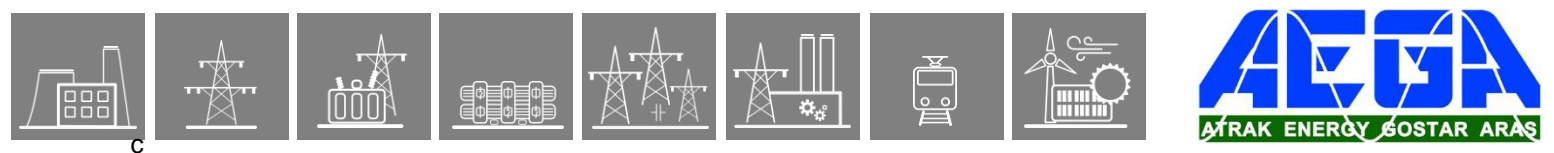

Figure 5-4 Result of single phase fault test, the fault is at the secondary side, supplied from the primary side



2.1.37.12.2. Testing the restricted earth-fault protection

When testing a function, it is advised to disable all other functions to avoid trip commands generated by the other functions.

The applied test set supports the tests with 2*3 currents. With this test set the restricted earth-fault protection can be tested in two steps: Primary/Neutral, and Secondary/Neutral relationship. In all cases the currents of the not tested sides (Secondary or Primary respectively) is supposed to be zero. Note that the Tertiary side is not involved in the restricted earth-fault protection.

In the characteristic tests please consider that the Idiff differential current in the restricted earth-fault protection function is the vectorial sum of six phase currents plus the neutral current. The I_{bias} current is the maximum of these seven currents.

2.1.37.12.2.1. Characteristic accuracy tests

This paragraph shows the tests in Pimary/Neutral relationship. Three-phase current are injected in the Primary side and the sum of the other three current set is injected in the Neutral.

Test Results for Fault Location L1-E at Reference Side Primary

I _{bias}	I _{diff} Nominal	I _{diff} Actual	Dev (rel)	Dev (abs)	Check Test	State	Result
0,50 In	0,500 In	0,503 In	0,63 %	0,0031 In		Tested	Passed
1,00 In	0,500 In	0,447 In	-10,62 %	-0,0531 In		Tested	Passed
1,50 In	0,625 In	0,612 In	-2,17 %	-0,0136 In		Tested	Passed
2,00 In	0,875 In	0,838 In	-4,29 %	-0,0375 In		Tested	Passed
4,00 In	1,876 In	1,880 In	0,20 %	0,0037 In		Tested	Passed
6,00 In	2,877 In	2,791 In	-2,97 %	-0,0855 In		Tested	Passed
8,00 In	3,877 In	3,798 In	-2,05 %	-0,0796 In		Tested	Passed
10,00 In	4,878 In	4,838 In	-0,82 %	-0,0401 In		Tested	Passed
12,00 In	5,878 In	5,848 In	-0,52 %	-0,0304 In		Tested	Passed
14,00 In	6,879 In	6,811 In	-0,99 %	-0,0681 In		Tested	Passed
16,00 In	7,880 In	7,802 In	-0,98 %	-0,0775 In		Tested	Passed
18,00 In	8,880 In	8,748 In	-1,49 %	-0,1320 In		Tested	Passed
20,00 In	9,881 In	9,885 In	0,04 %	0,0043 In		Tested	Passed

Operating Characteristic Diagram

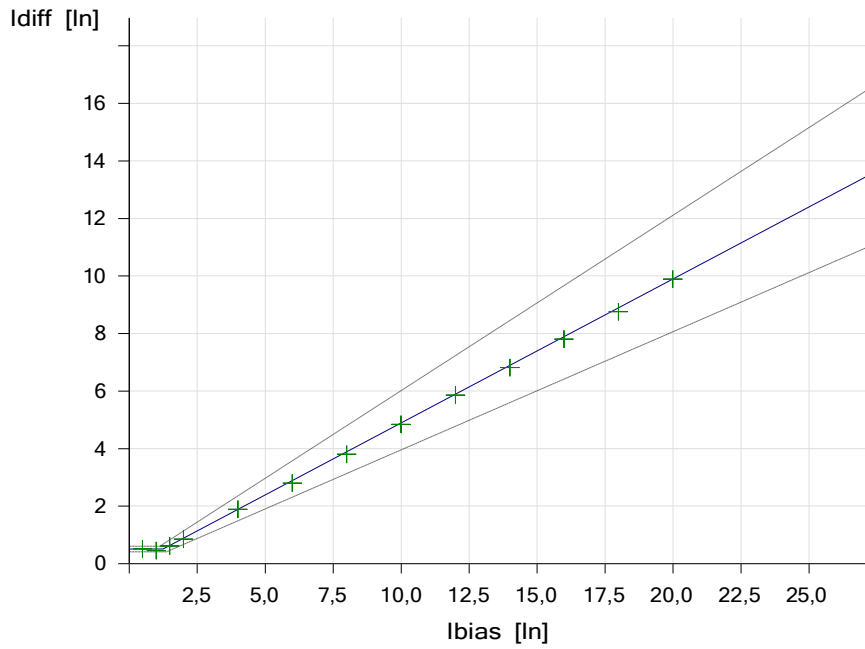

Figure 5-5 Result of characteristic accuracy test of the restricted earth-fault protection

2.1.37.13. Single shot fault simulation

In this test an external earth-fault is supposed at the secondary side with 1500A primary current. The primary current distribution is shown in Figure 5-6.

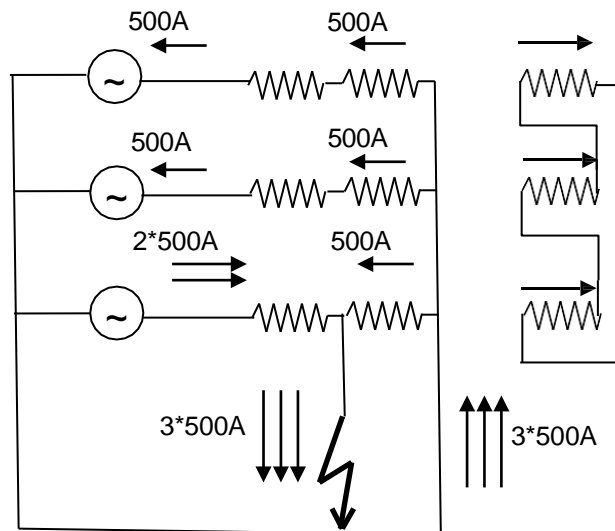

Figure 5-6 Primary current distribution

The currents are transformed to the device side by the current transformers:

$$I_{\text{primary L1}} = 2 \cdot 500 \text{ A} \cdot 1/300 = 3.33 \text{ A}$$

$$I_{\text{primary L2}} = I_{\text{primary L3}} = 500 \text{ A} \cdot 1/300 = 1.66 \text{ A}$$

$$I_{\text{secondary L1}} = 3 \cdot 500 \text{ A} \cdot 1/500 = 3 \text{ A}$$

$$I_{\text{neutral}} = 3 \cdot 500 \text{ A} \cdot 1/300 = 3.33 \text{ A}$$

These currents are drawn in [Figure 5-7](#). Note that the Kirchhoff's node law is satisfied with primary currents only. The secondary currents are transformed with CT with different ratios. (This deviation is compensated by the current matching parameters of the restricted earth-fault protection function.)

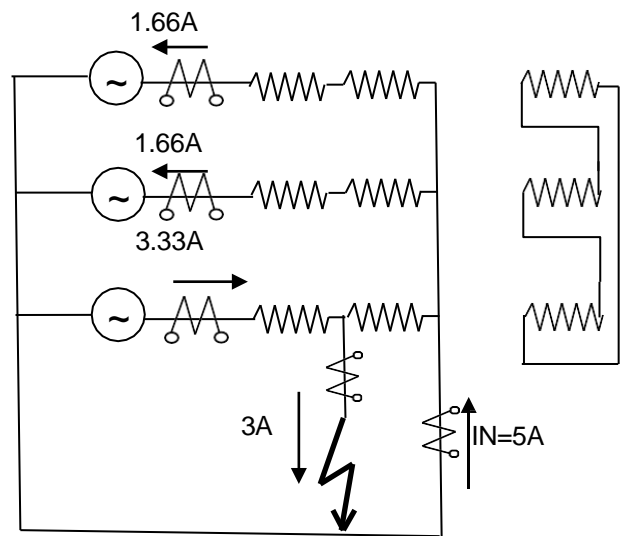

Figure 5-7 Secondary current distribution

NOTE. The current in the neutral point is measured with a CT of reverse polarity. This is not indicated in the figure.

[Figure 5-8](#) below shows the measured (secondary) currents of the CT modules. The first module shows the three currents of the primary side and the current in the grounding CT. The second module measures the single fault current of the secondary side. (The currents of the tertiary side are all zero.)



Figure 5-8 Measured currents of the CT modules

Figure 5-9 shows the displayed values by the restricted earth-fault protection function. The differential current value is small (not zero due to the not accurate current injection). The high bias (restraint) current prevents operation, i.e. the “General Trip” box is not checked in the figure. The behavior is correct.

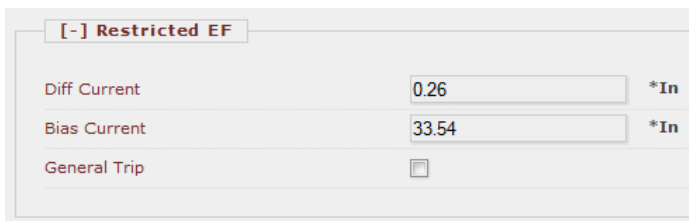

Figure 5-9 On-line display of the restricted earth-fault function with correct CT connection

If for example the grounding CT is reversed connected, then the function generates the trip command, due to the false high differential current (i.e. the “General Trip” box is checked in the figure). The behavior is correct.

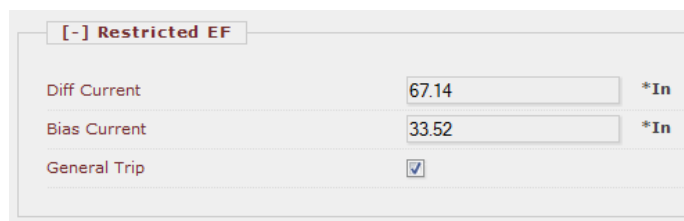

Figure 5-10 On-line display of the restricted earth-fault function with reverse CT connection in the grounding

2.1.37.13.1.1. Checking the directional blocking

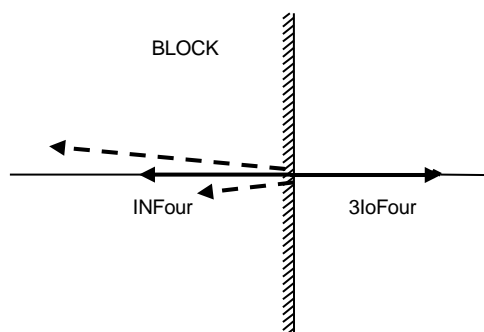

Figure 5-11 Checking the directional blocking

For checking the directional blocking, consider [Figure 5-11](#). For external fault the restricted earth-fault is balanced, the function does not generate the trip command. In this state the “3IoFour” vector, which is the sum of the currents of all phase current transformers has the same magnitude as “INFour” (solid vector on the figure), but the direction is opposite.

Now suppose that due to any measuring errors this balance is not fulfilled for external fault, and suppose that “INFour” is different in magnitude and/or phase angle. This is illustrated with dotted vectors. It is obvious that the difference of the solid “INFour” vector and the dotted version is the “Idiff” differential current, detected by the restricted earth-fault protection function. If this “Idiff” error current is large enough, the function generates the trip command.

For the test consider a balanced state, as shown in [Figure 5-7](#). Here the “INFour” current corresponds to $I_N=5A$. Increase /decrease the magnitude and/or phase angle of this vector to generate sufficient “Idiff” current for the operation of the restricted earth-fault protection function, if the Boolean parameter “Directional check” is FALSE (not checked).

NOTE: Remember that the “Ibias” is the maximum of any applied phase currents or the I_N neutral current. Considering this, for the trip command, the (I_{Bias}, I_{diff}) point must be above the characteristic.

Now change the parameter “Directional check” to TRUE (checked). In this state no trip command is generated if the phase angle between “3IoFour” and “INFour” is out of the range -90° to $+90^\circ$, this is the left side of [Figure 5-11](#). (An internal fault supposes that the phase angle between these vectors is in the range -90° to $+90^\circ$, this is the right side of [Figure 5-11](#).)

2.2. Control & supervision functions

2.2.1. Phase-Selective Trip Logic

2.2.1.1. Operation principle

The phase-selective trip logic function operates according to the functionality required by the IEC 61850 standard for the "Trip logic logical node".

2.2.1.1.1. Application

The phase-selective function is applied when one-phase trip commands might be required, mostly in distance protection applications.

The function receives the trip requirements of the protective functions implemented in the device and combines the binary signals and parameters to the outputs of the device.

The trip requirements are programmed by the user, using the graphic equation editor. The decision logic has the following aims:

- Define a minimal impulse duration even if the protection functions detect a very short time fault,
- In case of phase-to-phase faults, involve the third phase in the trip command,
- Fulfill the requirements of the automatic reclosing function to generate a three-phase trip command even in case of single-phase faults,
- In case of an evolving fault, during the evolving fault waiting time include all three phases into the trip command

2.2.1.1.2. The decision logic

The decision logic module combines the status signals and the enumerated parameter to generate the general trip command on the output module of the device.

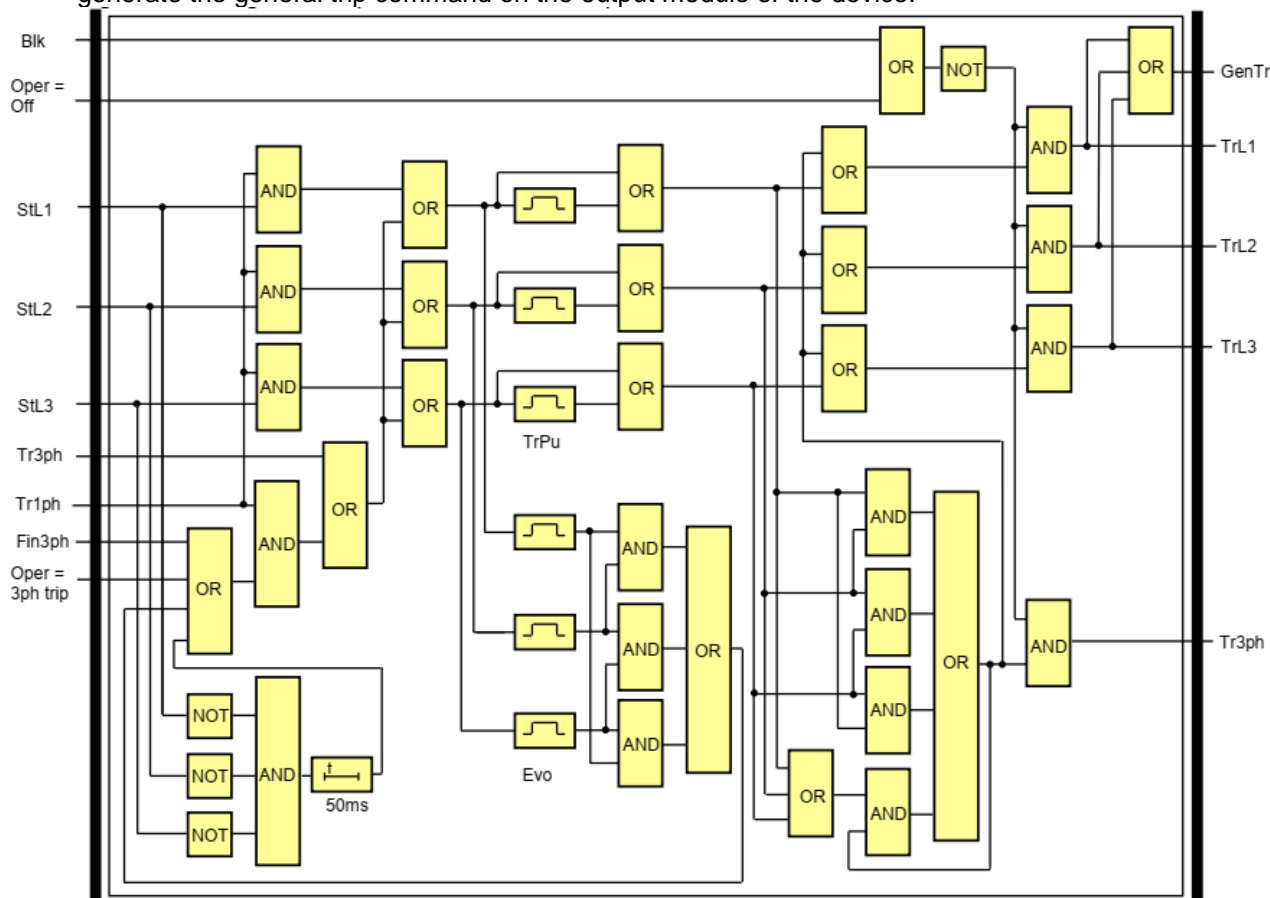

Figure 1-1 Logic scheme of the decision logic

2.2.1.2. PhSel. Trip logic function overview

The graphic appearance of the function block of the phase-selective trip logic function is shown in the figure below.

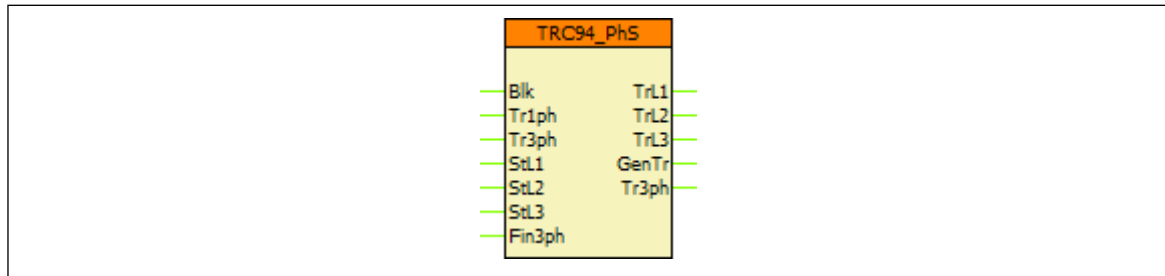

Figure 2-1 Graphic appearance of the function block of the phase-selective trip logic function

2.2.1.2.1. Settings

2.2.1.2.1.1. Parameters

TITLE	DIM	RANGE	STEP	DEFAULT	EXPLANATION
Operation	-	Off, 3ph trip, 1ph/3ph trip	-	Off	Selection of the operating mode
Min Pulse Duration	ms	50 – 60000	1	150	Minimum duration of the generated pulse
Evolving Fault Time	ms	50 – 60000	1	1000	Waiting time for evolving fault

Table 2-1 Parameters of the phase-selective trip logic function

2.2.1.2.2. Function I/O

This section describes briefly the analogue and digital inputs and outputs of the function block.

2.2.1.2.2.1. Analogue inputs

This function does not have analogue inputs.

2.2.1.2.2.2. Analogue outputs (measurements)

This function does not have measurements.

2.2.1.2.2.3. Binary input signals (graphed output statuses)

The conditions of the inputs are defined by the user, applying the graphic equation editor (logic editor). The part written in **bold** is seen on the function block in the logic editor.

BINARY INPUT SIGNAL	EXPLANATION
TRC94 Blk GrO_	Blocking the outputs of the function
TRC94 Tr1ph GrO_	Request for single-phase trip command
TRC94 Tr3ph GrO_	Request for three-phase trip command
TRC94 StL1 GrO_	Request for trip command in phase L1
TRC94 StL2 GrO_	Request for trip command in phase L2
TRC94 StL3 GrO_	Request for trip command in phase L3
TRC94 Fin3ph GrO_	Forcing three-phase trip even in case of single-phase fault

Table 2-2 The binary input signals of the phase-selective trip logic function

2.2.1.2.2.4. Binary output signals (graphed input statuses)

The binary output status signals of the differential protection function. Parts written in **bold** are seen on the function block in the logic editor.

BINARY OUTPUT SIGNAL	SIGNAL TITLE	EXPLANATION
TRC94_TrL1_Grl_	Trip L1	Generated trip command for phase L1
TRC94_TrL2_Grl_	Trip L2	Generated trip command for phase L2
TRC94_TrL3_Grl_	Trip L3	Generated trip command for phase L3
TRC94_GenTr_Grl_	General Trip	Generated general trip command (active for 1ph and 3ph trips as well)
TRC94_Tr3ph_Grl_	3Ph Trip	Generated three-phase trip command

Table 2-3 The binary output signal of the phase-selective trip logic function

2.2.1.2.2.5. On-line data

Visible values on the on-line data page:

SIGNAL TITLE	DIMENSION	EXPLANATION
General Trip	-	Status of the General Trip binary output
Trip L1	-	Status of the Trip L1 binary output
Trip L2	-	Status of the Trip L2 binary output
Trip L3	-	Status of the Trip L3 binary output
3Ph Trip	-	Status of the 3Ph Trip binary output

Table 2-4 On-line data of the phase-selective trip logic function

2.2.1.2.2.6. Events

The following events are generated in the event list, as well as sent to SCADA according to the configuration.

EVENT	VALUE	EXPLANATION
Trip L1	off, on	Status of the Trip L1 binary output
Trip L2	off, on	Status of the Trip L2 binary output
Trip L3	off, on	Status of the Trip L3 binary output
General Trip	off, on	Status of the General Trip binary output

Table 2-5 Event of the phase-selective trip logic function

2.2.1.2.3. Technical data

FUNCTION	VALUE	ACCURACY
Pulse time		< 3 ms

Table 2-6 The technical data of the phase-selective trip logic function

2.2.1.2.3.1. Notes for testing

When using an EuroProt+ device with phase-selective trip logic, the first 3 trip contacts of the trip module are assigned to the corresponding Trip L1-L2-L3 outputs of the Trip Logic function block. These assignments can be checked in the configuration file of the device by using the EuroCAP tool (see the picture below, note that the actual configuration might be different from that of on the figure). It is possible to assign multiple contacts to one trip logic output (mainly when two trip circuits are used).

▼ E1-Line_F

- ▼ Hardware Configuration
 - Connector allocation
 - LED assignment
 - ▼ IO Signals
 - > Analogue Inputs
 - > Analogue Outputs
 - > Binary Inputs
 - > Binary Outputs
 - ▼ Trip definition
 - ▼ Assignment
 - > Communication
 - > Software Configuration
 - > Subscribed GOOSE assignment
 - > System

Trip definition / Assignment

Add

Insert

Remove

Modify

Move Up

Move Dn

Ix	Name	Title	Defined by	Show order	Parameters	Type
0	TripAssign1	Trip L1	RootFunctionBlock		TRC94_TripL1_TLO_TripContact_O02	4444 Trip assign
1	TripAssign2	Trip L2	RootFunctionBlock		TRC94_TripL2_TLO_TripContact_O04	4444 Trip assign
2	TripAssign3	Trip L3	RootFunctionBlock		TRC94_TripL3_TLO_TripContact_O06	4444 Trip assign

Figure 2-2 Trip assignment in EuroCAP

During commissioning the testing personnel must make sure that, along with the protection functions under test, the corresponding Trip Logic(s) is (are) switched on ('Operation' parameter is set to other than 'Off') before starting the testing, otherwise there will be no actual trip signal given on the assigned trip contacts.

2.2.2. Circuit breaker wear monitoring function

If a circuit breaker interrupts a current, the electric arc between the contacts results some metal loss. If the metal loss due to the burning of the electric arc becomes substantial, the contacts must be replaced.

Manufacturers define the permitted number of short circuits by formulas such as:

$$\sum_{i=1}^n I_i^k = CycNum$$

where

n = number of short circuits

k = exponent, calculated by the algorithm, based on the parameters I = short-circuit current, kA (RMS)

CycNum = total value of weighted breaking currents.

Similar information is conveyed by the diagram below. This shows the number of permitted interruptions (logarithmic scaling) versus short-circuit current (logarithmic scaling) that the contacts in a circuit breaker can manage before the metal loss due to burning becomes so significant that the contacts must be replaced.

Number of interruptions

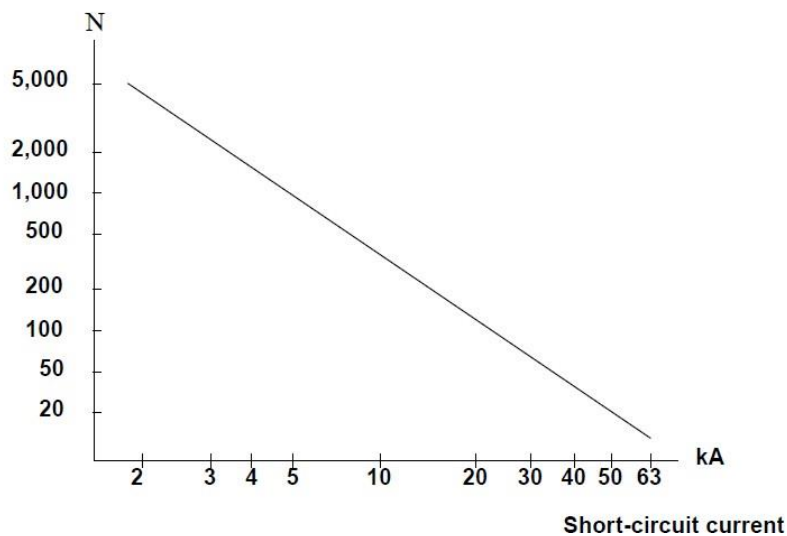
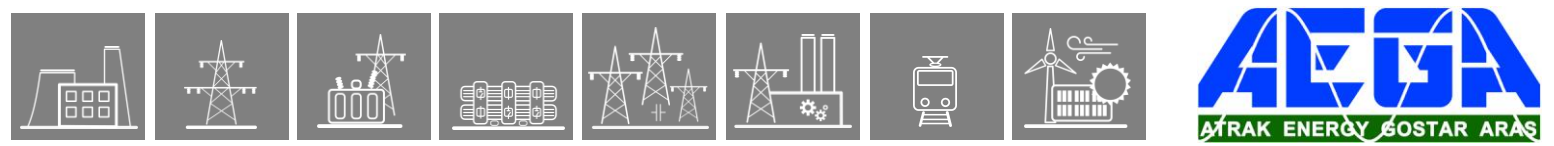

Figure 1-1 Example: Number of permitted interruptions as the function of the interrupted current

The straight line of the curve is defined by two points:

- The number of permitted interruptions of 1 kA current (CycNum - 1kA)
- The number of permitted interruptions of the rated breaking current of the circuit breaker (CycNum – I Rated Trip).

The circuit breaker wear monitoring function finds the maximum value of the phase currents of each interruption and calculates the wear caused by the operation performed. If the sum of the calculated wear reaches the limit, a warning signal is generated. This indicates the time of the required preventive maintenance of the circuit breaker.



2.2.2.1. Operation of the circuit breaker wear monitoring algorithm

The operating principle of the circuit breaker wear monitoring function is based on curves similar to the one shown in [Figure 1-1](#). With this figure, the manufacturer of the circuit breaker defines the permitted total number of current interruptions up to the subsequent preventive maintenance.

The straight line of the curve is defined by two points:

- The number of interruptions of 1 kA current, by parameter `CBWear_CycNumIn_IPar_` (`CycNum - 1kA`)
- The number of interruptions of the rated breaking current of the circuit breaker by parameter `CBWear_CycNumInTrip_IPar_` (`CycNum - I Rated Trip`). The rated breaking current of the circuit breaker is set by parameter `CBWear_InTrCB_FPar_` (`Rated Trip Current`)

The circuit breaker wear monitoring function processes the Fourier basic harmonic component of the three phase currents.

The circuit breaker wear monitoring function identifies the highest value of the phase currents at each interruption.

The procedure of monitoring starts at the receipt of a trip command on the dedicated input (`Trip`). For the start of this procedure, the circuit breaker also needs to be in closed state. This signal is received on the dedicated binary input (`CB Closed`).

The procedure of identifying the maximum phase current value terminates when the current falls below the minimum current defined by the parameter `CBWear_Imin_FPar_` (`Min Current`) AND the circuit breaker gets in open position. This signal is received on the dedicated binary input (`CB Open`).

The procedure also stops if the time elapsed since its start exceeds 1 s. In this case no CB wear is calculated.

Based on the characteristic defined above, the function calculates the wear caused by the operation performed. If the sum of the calculated wear reaches the limit defined by the parameter `CBWear_CycNumAlm_IPar_` (`CycNum - Alarm`), a warning signal is generated (`Alarm`). This indicates the advised time of the preventive maintenance of the circuit breaker.

The accumulated “wear” of the circuit breaker is stored on non-volatile memory; therefore, the value is not lost even if the power supply of the devices is switched off.

This information is displayed among the on-line data as “Actual wear”. This counter indicates how many 1 kA equivalent switches were performed since the last maintenance (reset).

When preventive maintenance is performed, the accumulated “wear” of the circuit breaker must be reset to 0 to start a new maintenance cycle. The circuit breaker wear monitoring function offers two ways of resetting:

- Binary True signal programmed to the “Reset” input of the function
- Performing a direct command via the Commands menu of the supervising WEB browser (for details, see the “Europrot+ manual”, “Remote user interface description” document). The Command window looks like [Figure 1-2](#).



Figure 1-2 The command window to reset the CB wear counter

The **inputs** of the circuit breaker wear monitoring function are

- the Fourier components of three phase currents,
- binary inputs,
- parameters.

The **output** of the circuit breaker wear monitoring function is

- the Alarm binary output status signal.

2.2.2.2. Technical summary

2.2.2.2.1. Technical data

Function	Range	Accuracy
Current accuracy	20 – 2000% of I_n	$\pm 1\%$ of I_n
Accuracy in tracking the theoretical wear characteristics		5%

Table 1-1 Technical data of the circuit breaker wear monitoring

2.2.2.2.2. Summary of the parameters

The parameters of the circuit breaker wear monitoring function are explained in the following tables.

Enumerated parameter

Parameter name	Title	Selection range	Default
Disabling or enabling the operation of the function			
CBWear_Oper_EPar_	Operation	Off,On	Off

Table 1-2 The enumerated parameter of the circuit breaker wear monitoring function

Integer parameters

Parameter name	Title	Unit	Min	Max	Step	Default
Permitted number of trip operation if the breaking current is 1kA						
CBWear_CycNumIn_IPar_	CycNum - 1kA		1	100000	1	50000
Permitted number of trip operation if the breaking current is InTrip (See floating parameter "Rated Trip Current")						
CBWear_CycNumInTrip_IPar_	CycNum – I Rated Trip		1	100000	1	100
Permitted level of the weighted sum of the breaking currents						
CBWear_CycNumAlm_IPar_	CycNum - Alarm		1	100000	1	50000

Table 1-3 The integer parameters of the circuit breaker wear monitoring function

Floating point parameters

Parameter name	Title	Unit	Min	Max	Step	Default
Rated breaking current of the circuit breaker						
CBWear_InTrCB_FPar_	Rated Trip Current	kA	10	100	0.01	10
Minimum level of the current below which the procedure to find the highest breaking current is stopped						
CBWear_lmin_FPar_	Min Current	kA	0.10	0.50	0.01	0.10

Table 1-4 The floating-point parameters of the circuit breaker wear monitoring function

2.2.2.2.3. Binary output status signals

The **binary output status signals** of the circuit breaker wear monitoring function.

Binary output signals	Signal title	Explanation
Alarm signal of the function block		
CBWear_Alarm_GrI_	Alarm	Alarm signal is generated if the weighted sum of the breaking currents is above the permitted level

Table 1-5 The binary output status signal of the circuit breaker wear monitoring function

2.2.2.2.4. The binary input status signals

The **binary inputs** are signals influencing the operation of the circuit breaker wear monitoring function. These signals are the results of logic equations graphically edited by the user.

Binary input signals	Signal title	Explanation
Disabling the function		
CBWear_BlK_GrO_	Blk	The programmed True state of this input disables the operation of the function
Open state of the circuit breaker		
CBWear_Open_GrO_	Open	The open state of the circuit breaker is needed to stop the procedure to find the maximum breaking current
Closed state of the circuit breaker		
CBWear_Closed_GrO_	Closed	The closed state of the circuit breaker is needed to perform the procedure to find the maximum breaking current

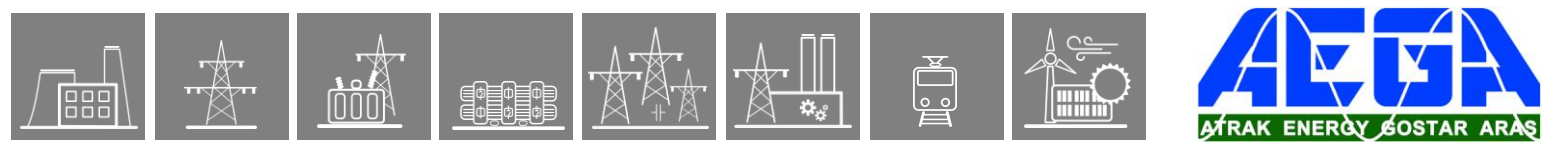

Trip command to the circuit breaker		
CBWear_Trip_GrO_	Trip	This signal starts the procedure to find the highest breaking current
Reset command		
CBWear_Reset_GrO_	Reset	If this input is programmed to logic True, at maintenance the weighted sum of the breaking currents can be set to 0

Table 1-6 The binary input signals of the circuit breaker wear monitoring function

2.2.2.2.5. The function block

The function block of the circuit breaker wear monitoring function is shown in [Figure 1-3](#). This block shows all binary input and output status signals that are applicable in the graphic equation editor.

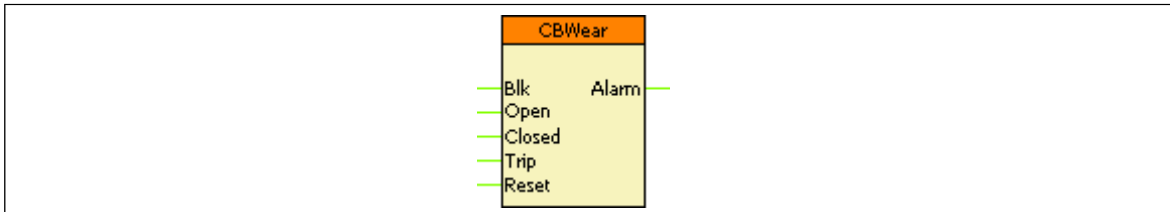

Figure 1-3 The function block of the circuit breaker wear monitoring function



2.2.3. Circuit breaker control function block

2.2.3.1. Application

The circuit breaker control block can be used to integrate the circuit breaker control of the EuroProt+ device into the station control system and to apply active scheme screens of the local LCD of the device.

2.2.3.1.1. Mode of operation

The circuit breaker control block receives remote commands from the SCADA system and local commands from the local LCD of the device, performs the prescribed checking and transmits the commands to the circuit breaker. It processes the status signals received from the circuit breaker and offers them to the status display of the local LCD and to the SCADA system.

Main features:

- Local (LCD of the device) and Remote (SCADA) operation modes can be enabled or disabled individually.
- The signals and commands of the synchro-check / synchro-switch function block can be integrated into the operation of the function block.
- Interlocking functions can be programmed by the user applying the inputs “EnaOff” and “EnaOn”, using the graphic equation editor.
- Programmed conditions can be used to temporarily disable the operation of the function block using the graphic equation editor.
- The function block supports the control models prescribed by the IEC 61850 standard.
- All necessary timing tasks are performed within the function block:
 - Time limitation to execute a command
 - Command pulse duration
 - Filtering the intermediate state of the circuit breaker
 - Checking the synchro-check and synchro-switch times
 - Controlling the individual steps of the manual commands
- Sending trip and close commands to the circuit breaker (to be combined with the trip commands of the protection functions and with the close command of the automatic reclosing function; the protection functions and the automatic reclosing function directly gives commands to the CB). The combination is made graphically using the graphic equation editor
- Operation counter
- Event reporting

2.2.3.2. Circuit Breaker control function overview

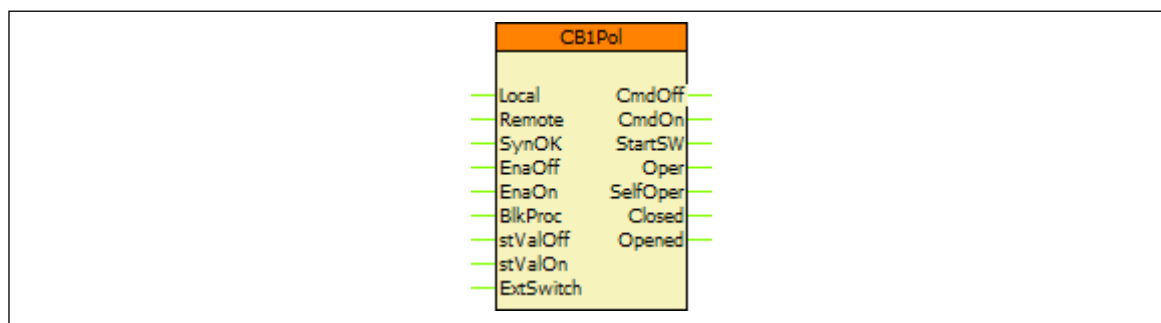

Figure 2-1 Graphic appearance of the function block of the circuit breaker control function

2.2.3.3. Settings

2.2.3.3.1. Parameters

TITLE	DIM	RANGE	STEP	DEFAULT	EXPLANATION
ControlModel	-	Direct normal, Direct enhanced, SBO enhanced	-	Direct normal	The control model of the circuit breaker node according to the IEC 61850 standard
Forced Check	-	FALSE, TRUE	-	TRUE	If true, then the check function cannot be neglected by the check attribute defined by the IEC 61850 standard
Max Operating Time	ms	10 – 1000	1	200	When either enhanced control model is selected, the status of the CB must change within this time after the issued command. At timeout an invalid-position error will be generated for the client.
Pulse Duration	ms	50 – 1000	1	300	Duration of the generated On and Off impulse*
Max Intermediate Time	ms	20 – 500	1	100	Waiting time for status signals, at expiry the CB is reported to be in intermediate state
Max SynCheck Time	ms	10 – 5000	1	1000	Length of the time period to wait for the conditions of the synchronous state. After expiry of this time, the synchro-switch procedure is initiated (see synchro-check/ synchro-switch function block description)
Max SynSW Time**	ms	0 – 60000	1	0	Length of the time period to wait for the synchro-switch impulse (see synchro-check/ synchro-switch function block description). After this time the function resets, no switching is performed
SBO Timeout	ms	1000 – 20000	1	5000	Duration of the waiting time between object selection and command selection. At timeout no command is performed

* If the input status signals (stValOff, stValOn) indicate the successful switching then the pulse is withdrawn, but the minimum duration is 100 ms (factory setting).

** If this parameter is set to 0, then the “StartSW” output is not activated

Table 2-1 Parameters of the circuit breaker control function

2.2.3.3.2. Function I/O

This section describes briefly the analogue and digital inputs and outputs of the function block.

2.2.3.3.2.1. Binary input signals (graphed output statuses)

The conditions of the inputs are defined by the user, applying the graphic equation editor (logic editor). The part written in **bold** is seen on the function block in the logic editor.

BINARY INPUT SIGNAL	EXPLANATION
CB1Pol_ Local _GrO_	If this input is active, the circuit breaker can be controlled using the local LCD of the device.
CB1Pol_ Remote _GrO_	If this input is active, the circuit breaker can be controlled via remote communication channels of the SCADA system or the device web page ('commands' menu)
CB1Pol_ SynOK _GrO_	This input indicates if the synchronous state of the voltage vectors at both sides of the circuit breaker enables the closing command. This signal is usually generated by the synchro check/ synchro switch function. If this function is not available, set the input to logic true.
CB1Pol_ EnaOff _GrO_	The active state of this input enables the opening of the circuit breaker. The state is usually generated by the <i>interlocking conditions defined graphically by the user</i> .
CB1Pol_ EnaOn _GrO_	The active state of this input enables the closing of the circuit breaker. The state is usually generated by the <i>interlocking conditions defined graphically by the user</i> .
CB1Pol_ BlkProc _GrO_	The active state of this input blocks the operation of the circuit breaker. The conditions are defined graphically by the user.
CB1Pol_ stValOff _GrO_	Off (Opened) state of the circuit breaker.
CB1Pol_ stValOn _GrO_	On (Closed) state of the circuit breaker.
CB1Pol_ ExtSwitch _GrO_	This signal is considered only when evaluating unintended operation (see "SelfOper" output in Chapter 2.2.2). It indicates that an external command has been issued to the circuit breaker (e.g. trip request from other protection device or external on/off command is given).

Table 2-2 The binary input signals of the circuit breaker control function

2.2.3.3.2.2. Binary output signals (graphed input statuses)

The binary output status signals of the differential protection function. Parts written in **bold** are seen on the function block in the logic editor.

BINARY OUTPUT SIGNAL	SIGNAL TITLE	EXPLANATION
CB1Pol_ CmdOff _Grl_	Off Command	Off command impulse, the duration of which is defined by the parameter "Pulse duration"
CB1Pol_ CmdOn _Grl_	On Command	On command impulse, the duration of which is defined by the parameter "Pulse duration"
CB1Pol_ StartSW _Grl_	Start Synchro-switch	If the synchro check/synchro switch function is applied and the synchronous state conditions are not valid for the time defined by the parameter "Max.SynChk time", then this output triggers the synchro switch function (see synchro-check/synchro-switch function block description).
CB1Pol_ Oper _Grl_	Operation	An impulse with a duration of 150 ms at any operation of the circuit breaker
CB1Pol_ SelfOper _Grl_	Unintended Operation	This output is logic true if the status of the circuit breaker has changed without detected command from the SCADA system or on the input "ExtSwitch"
CB1Pol_ Closed _Grl_	Closed	The filtered status signal for closed state of the circuit breaker
CB1Pol_ Opened _Grl_	Opened	The filtered status signal for opened state of the circuit breaker

Table 2-3 The binary output signals of the circuit breaker control function

2.2.3.3.2.3. On-line data

Visible values on the on-line data page:

SIGNAL TITLE	DIMENSION	EXPLANATION
Status	-	State of the CB (see Chapter 2.2.6)
Off Command	-	Off command impulse, the duration of which is defined by the parameter "Pulse duration"
On Command	-	On command impulse, the duration of which is defined by the parameter "Pulse duration"
Operation	-	An impulse with a duration of 150 ms at any operation of the circuit breaker
Unintended Operation	-	This output is logic TRUE if the status of the circuit breaker has changed without detected command from the SCADA system or on the input "ExtSwitch"
Opened	-	The filtered status signal for opened state of the circuit breaker
Closed	-	The filtered status signal for closed state of the circuit breaker
Operation counter	-	Resettable* counter that increments every time the Operation (see above) output gets active

*The operation counter can be reset on the device web page on-line menu.

Table 2-4 On-line data of the circuit breaker control function

2.2.3.3.2.4. Events

The following events are generated in the event list, as well as sent to SCADA according to the configuration.

EVENT	VALUE	EXPLANATION
Status	Intermediate,Off,On,Bad	CB state indication based on the received signals

Table 2-5 Event of the circuit breaker control function

2.2.3.3.2.5. Commands

The following table contains the issuable commands of the function block. The name of the command channel is used while working in the EuroCAP configuration tool, whereas the title is seen by the user on the device web page.

COMMAND CHANNEL	TITLE	RANGE	EXPLANATION
CB1Pol_Oper_Con_	Operation	Off,On	Issue open (off) or close (on) command on the corresponding outputs of the function block

Table 2-6 The command of the circuit breaker control function

2.2.3.3.2.6. Indication of the four states (Intermediate, On, Off, Bad)

To generate an active scheme on the local LCD, there is an internal status variable indicating the state of the circuit breaker. Different graphic symbols can be assigned to the values, the function block's events are generated also according to this status variable.

This integer status has four values based on the states of the **stValOn** and **stValOff** inputs of the function block.

INTEGER STATUS	TITLE	STVALON STATE	STVALOFF STATE	VALUE	EXPLANATION
CB1Pol_stVal_ISt_	Status	FALSE	FALSE	0: Intermediate	Integer status signal for indicating the state of the CB according to the corresponding inputs of the function block
		FALSE	TRUE	1: Off	
		TRUE	FALSE	2: On	
		TRUE	TRUE	3: Bad	

Table 2-7 State signals from the circuit breaker control function

2.2.3.3.3. Technical data

FUNCTION	VALUE	ACCURACY
Pulse time		< 3 ms

Table 2-8 The technical data of the circuit breaker control function

2.2.3.3.3.1. Notes for testing

If the commands get blocked from time to time during commissioning, it is advised to check how the conditions are fulfilled to issue commands on the function block. The following **three** conditions must be fulfilled at the same time:

- Local or Remote input is active appropriately
- The enabling input (EnaOff or EnaOn) of the issued command (off or on) is active
- (close/on command only) Synchro-check is OK (SynOK input is active)

If there are no conditions to be defined for any of these three (e.g. there is no synchro-check function present, so no valid signal can be provided to that input), the corresponding input can be connected to constant logical TRUE signal provided by the fixture output of the Common function block.

2.2.3.3.3.1.1. IEC 61850 commands

In several configurations the Interlocking and Control logical nodes may have the same prefix for CB and DC function blocks (**INTCILO#** and **SBwCSWI#** respectively where the '#' marks the instance number). This means that their instance number not necessarily corresponds to the actual function block:

- Example: if there are **2** DC and **1** CB function blocks in the same configuration where the former ones were added first, the instance number **#1** and **#2** will belong to the DC function blocks whereas number **#3** will belong to the CB function block even if it is the only CB control function in the device.
- Make sure to check which logical nodes belong to which function by checking the DOI description using the EuroCAP tool (right click the function block in the Logic editor)

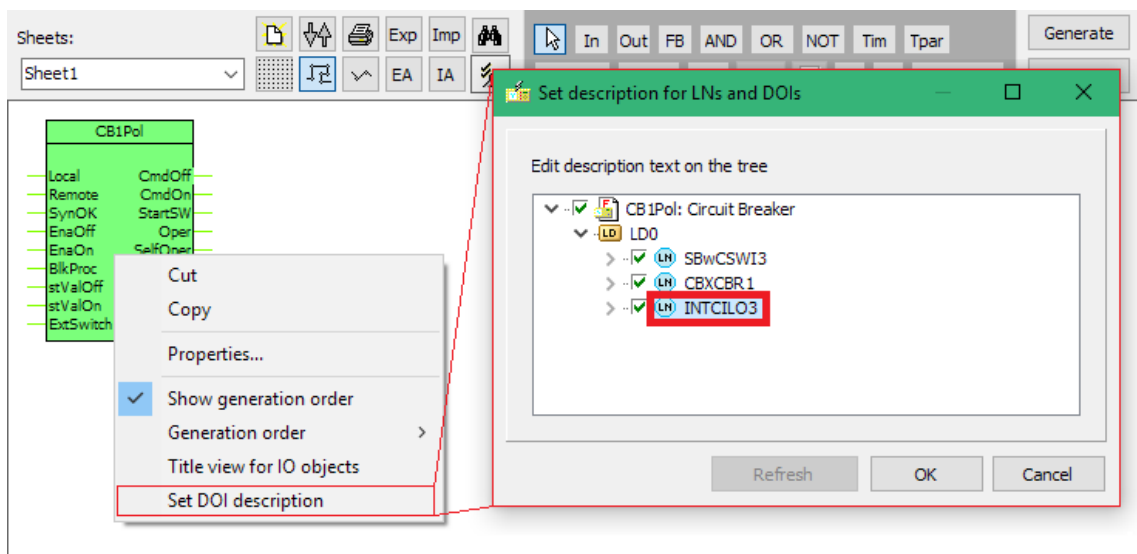

Figure 2-2 Checking the description of the Interlocking LN of the function block

In other cases, the two prefixes are given according to the type of the function block, so they are individual for each (i.e. **CBCILO#** and **CBCSW#** for circuit breaker and **DCCILO#** and **DCCSW#** for disconnector).



2.2.4. Disconnecter control function

2.2.4.1. Application

The disconnector control block can be used to integrate the disconnector control of the EuroProt+ device into the station control system and to apply active scheme screens of the local LCD of the device.

2.2.4.1.1. Mode of operation

The disconnector control block receives remote commands from the SCADA system and local commands from the local LCD of the device, performs the prescribed checking and transmits the commands to the disconnector. It processes the status signals received from the disconnector and offers them to the status display of the local LCD and to the SCADA system.

Main features:

- Local (LCD of the device) and Remote (SCADA) operation modes can be enabled or disabled individually.
- Interlocking functions can be programmed by the user applying the inputs “EnaOff” and “EnaOn”, using the graphic equation editor.
- Programmed conditions can be used to temporarily disable the operation of the function block using the graphic equation editor.
- The function block supports the control models prescribed by the IEC 61850 standard.
- All necessary timing tasks are performed within the function block:
 - Time limitation to execute a command
 - Command pulse duration
 - Filtering the intermediate state of the disconnector
 - Controlling the individual steps of the manual commands
- Sending open and close commands to the disconnector
- Operation counter
- Event reporting

2.2.4.2. Disconnecter control function overview

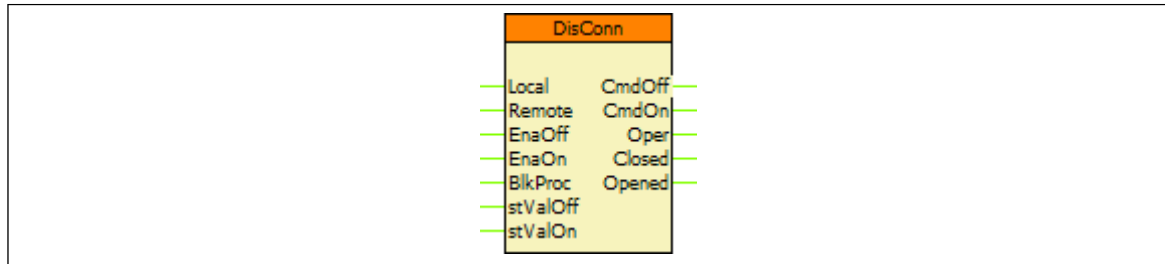

Figure 2-1 Graphic appearance of the function block of the disconnecter control function

2.2.4.2.1. Settings

2.2.4.2.1.1. Parameters

TITLE	DIM	RANGE	STEP	DEFAULT	EXPLANATION
Control Model	-	Direct normal, Direct enhanced, SBO enhanced	-	Direct normal	The control model of the disconnecter node according to the IEC 61850 standard
Type of Switch	-	N/A, Load Break, Disconnecter, Earthing Switch, HS Earthing Switch	-	Disconnecter	
Forced Check	-	FALSE, TRUE	-	TRUE	If true, then the check function cannot be neglected by the check attribute defined by the IEC 61850 standard
Max Operating Time	ms	10 – 60000	1	10000	When either enhanced control model is selected, the status of the DC must change within this time after the issued command. At timeout an invalid-position error will be generated for the client.
Pulse Duration	ms	100 – 60000	1	1000	Duration of the generated On and Off impulse*
Max Intermediate Time	ms	20 – 60000	1	10000	Waiting time for status signals, at expiry the DC is reported to be in intermediate state
SBO Timeout	ms	1000 – 20000	1	5000	Duration of the waiting time between object selection and command selection. At timeout no command is performed

* If the input status signals (stValOff, stValOn) indicate the successful switching then the pulse is withdrawn, but the minimum duration is 1000 ms (factory setting).

Table 2-1 Parameters of the disconnecter control function

2.2.4.2.2. Function I/O

This section describes briefly the analogue and digital inputs and outputs of the function block.

2.2.4.2.2.1. Binary input signals (graphed output statuses)

The conditions of the inputs are defined by the user, applying the graphic equation editor (logic editor). The part written in **bold** is seen on the function block in the logic editor.

BINARY INPUT SIGNAL	EXPLANATION
DisConn_ Local _GrO_	If this input is active, the disconnector can be controlled using the local LCD of the device.
DisConn_ Remote _GrO_	If this input is active, the disconnector can be controlled via remote communication channels of the SCADA system or the device web page ('commands' menu)
DisConn_ EnaOff _GrO_	The active state of this input enables the opening of the disconnector. The state is usually generated by the <i>interlocking conditions defined graphically by the user</i> .
DisConn_ EnaOn _GrO_	The active state of this input enables the closing of the disconnector. The state is usually generated by the <i>interlocking conditions defined graphically by the user</i> .
DisConn_ BlkProc _GrO_	The active state of this input blocks the operation of the disconnector. The conditions are defined graphically by the user.
DisConn_ stValOff _GrO_	Off (Opened) state of the disconnector.
DisConn_ stValOn _GrO_	On (Closed) state of the disconnector.

Table 2-2 The binary input signals of the disconnector control function

2.2.4.2.2.2. Binary output signals (graphed input statuses)

The binary output status signals of the differential protection function. Parts written in **bold** are seen on the function block in the logic editor.

BINARY OUTPUT SIGNAL	SIGNAL TITLE	EXPLANATION
DisConn_ CmdOff _Grl_	Off Command	Off command impulse, the duration of which is defined by the parameter "Pulse duration"
DisConn_ CmdOn _Grl_	On Command	On command impulse, the duration of which is defined by the parameter "Pulse duration"
DisConn_ Oper _Grl_	Operation	An impulse with a duration of 150 ms at any operation of the disconnector
DisConn_ Closed _Grl_	Closed	The filtered status signal for closed state of the disconnector
DisConn_ Opened _Grl_	Opened	The filtered status signal for opened state of the disconnector

Table 2-3 The binary output signals of the disconnector control function

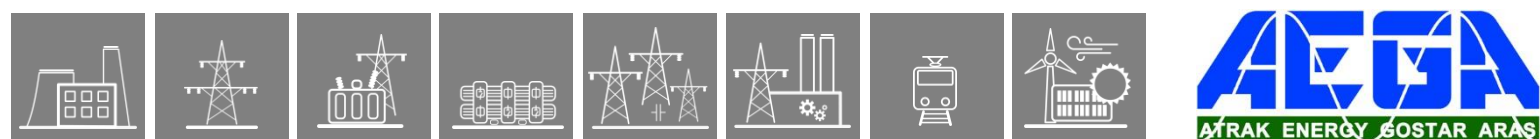

2.2.4.2.2.3. On-line data

Visible values on the on-line data page:

SIGNAL TITLE	DIMENSION	EXPLANATION
Status	-	State of the DC (see Chapter 2.2.6)
Off Command	-	Off command impulse, the duration of which is defined by the parameter "Pulse duration"
On Command	-	On command impulse, the duration of which is defined by the parameter "Pulse duration"
Operation	-	An impulse with a duration of 150 ms at any operation of the disconnector
Opened	-	The filtered status signal for opened state of the disconnector
Closed	-	The filtered status signal for closed state of the disconnector
Operation counter	-	Resettable* counter that increments every time the Operation (see above) output gets active

Table 2-4 On-line data of the disconnector control function

*The operation counter can be reset on the device web page on-line menu.

2.2.4.2.2.4. Events

The following events are generated in the event list, as well as sent to SCADA according to the configuration.

EVENT	VALUE	EXPLANATION
Status	Intermediate,Off,On,Bad	DC state indication based on the received status signals

Table 2-5 Event of the disconnector control function

2.2.4.2.2.5. Commands

The following table contains the issuable commands of the function block. The name of the command channel is used while working in the EuroCAP configuration tool, whereas the title is seen by the user on the device web page.

COMMAND CHANNEL	TITLE	RANGE	EXPLANATION
DisConn_Oper_Con_	Operation	Off,On	Issue open (off) or close (on) command on the corresponding outputs of the function block

Table 2-6 The command of the disconnector control function

2.2.4.2.2.6. Indication of the four states (Intermediate, On, Off, Bad)

To generate an active scheme on the local LCD, there is an internal status variable indicating the state of the disconnecter. Different graphic symbols can be assigned to the values, the function block's events are generated also according to this status variable.

This integer status has four values based on the states of the **stValOn** and **stValOff** inputs of the function block.

INTEGER STATUS	TITLE	STVALON STATE	STVALOFF STATE	VALUE	EXPLANATION
DisConn_stVal_ISt_	Status	FALSE	FALSE	0: Intermediate	Integer status signal for indicating the state of the DC according to the corresponding inputs of the function block
		FALSE	TRUE	1: Off	
		TRUE	FALSE	2: On	
		TRUE	TRUE	3: Bad	

Table 2-7 State signals from the disconnecter control function

2.2.4.2.3. Technical data

FUNCTION	VALUE	ACCURACY
Operate time		±5% or ±15 ms, whichever is greater

Table 2-8 The technical data of the disconnecter control function

2.2.4.2.3.1. Notes for testing

If the commands get blocked from time to time during commissioning, it is advised to check how the conditions are fulfilled to issue commands on the function block. The following **three** conditions must be fulfilled at the same time:

- Local or Remote input is active appropriately
- The enabling input (EnaOff or EnaOn) of the issued command (off or on) is active

If there are no conditions to be defined for any of these two (e.g. there is no difference made between local/remote control), the corresponding input can be connected to constant logical TRUE signal provided by the fixture output of the Common function block.

2.2.4.2.3.1.1. IEC 61850 commands

In several configurations the Interlocking and Control logical nodes may have the same prefix for DC and CB function blocks (**INTCILO#** and **SBwCSWI#** respectively where the '#' marks the instance number). This means that their instance number not necessarily corresponds to the actual function block:

- Example: if there are **1** CB and **1** DC function blocks in the same configuration where the former was added first, the instance number **#1** will belong to the CB function block whereas number **#2** will belong to the DC function block even if it is the only DC control function in the device.
- Make sure to check which logical nodes belong to which function by checking the DOI description using the EuroCAP tool (right click the function block in the Logic editor)

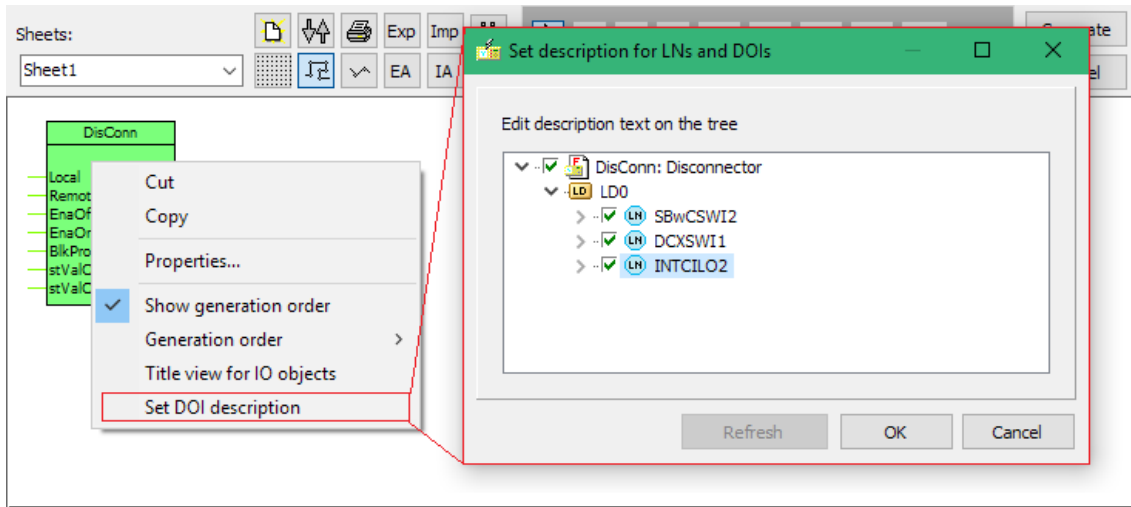

Figure 2-2 Checking the description of the Interlocking LN of the function block

In other cases, the two prefixes are given according to the type of the function block, so they are individual for each (i.e. **DCCILO#** and **DCCSW#** for disconnecter and **CBCILO#** and **CBCSW#** for circuit breaker).

2.2.4.3. Example logic

A simple example can be seen below of how to insert the function block in the user logic using the EuroCAP Logic Editor:

- The Local/Remote state of the device is provided by the Common function block which is present in all configurations
- The connections to the BIn and BOut elements show the connections to the physical input and output contacts
- The highlighted signal leading to the EnaOff and EnaOn inputs is the realization of the interlocking logic. In this case the disconnecter can operate only if the circuit breaker is opened.

The opened state of the CB is now indicated by its filtered 'Opened' signal which is active only if the CB is open and there is no state error (or intermediate state) of it.

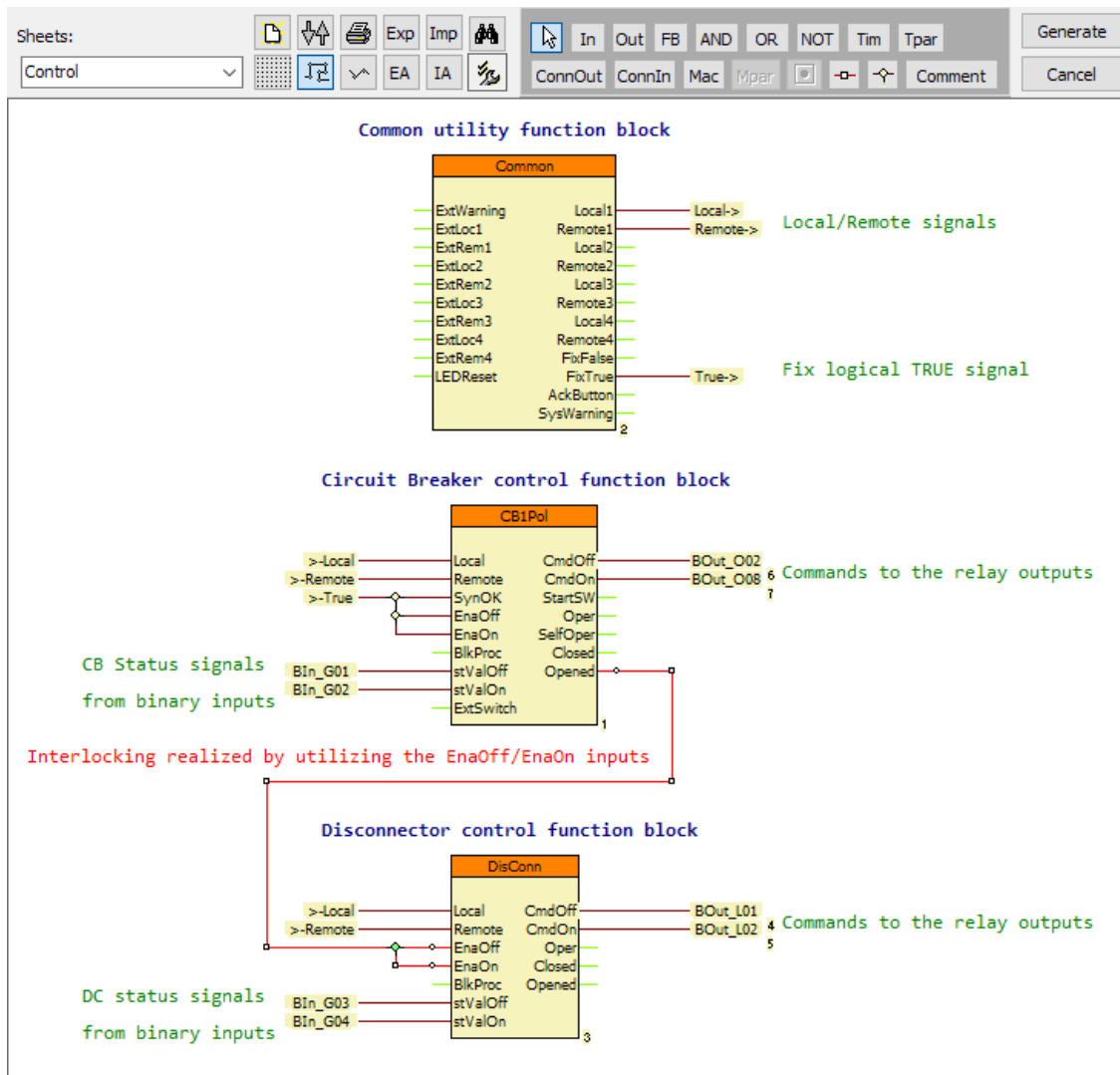

Figure 3-1 Inserting the disconnector function block into the logic (example)

2.2.5.2. Ethernet Links function overview

The graphic appearance of the function block is shown on [Figure 2-1](#). These blocks show all binary input and output status signals, which are applicable in the graphic equation editor.

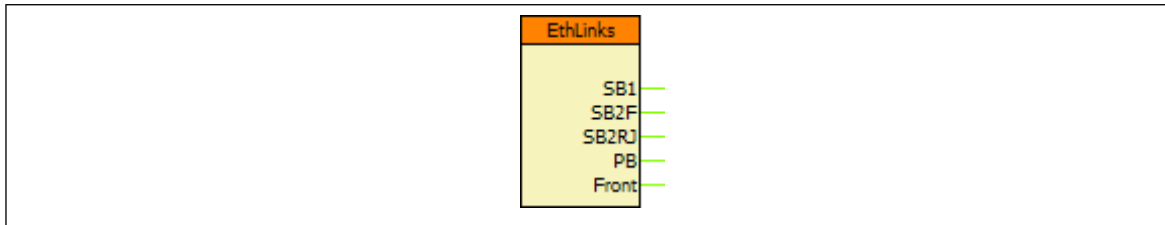

Figure 2-1 Graphic appearance of the function block of the ethernet links function

2.2.5.2.1. Settings

There are no settings for this function block.

2.2.5.2.2. Function I/O

This section describes briefly the analogue and digital inputs and outputs of the function block.

This function block owns only binary output signals.

2.2.5.2.2.1. Binary output signals (graphed input statuses)

The binary output status signals of the Ethernet Links function. **Parts written in bold** are seen on the function block in the logic editor.

BINARY OUTPUT SIGNAL	SIGNAL TITLE	EXPLANATION
EthLnk_ SB1 _Grl_	Station Bus1	Active if the first (upper) fiber optic port of the CPU module has an active connection.
EthLnk_ SB2F _Grl_	Station Bus2 – Fiber	Active if the second (middle) fiber optic port of the CPU module has an active connection.
EthLnk_ SB2RJ _Grl_	Station Bus2 –RJ4	Active if the RJ45 port of the CPU module has an active connection.
EthLnk_ PB _Grl_	Process Bus	Active if the third (lower) fiber optic port of the CPU module has an active connection
EthLnk_ Front _Grl_	RJ45/EOB on front panel	Active if the front RJ45 port (or EOB) has an active connection

Table 2-1 The binary output status signals of the ethernet links function

2.2.5.2.2.2. On-line data

Visible values on the on-line data page:

SIGNAL TITLE	DIMENSION	EXPLANATION
Station Bus1	-	Active if the first (upper) fiber optic port of the CPU module has an active connection.
Station Bus2 – Fiber	-	Active if the second (middle) fiber optic port of the CPU module has an active connection.
Station Bus2 –RJ4	-	Active if the RJ45 port of the CPU module has an active connection.
Process Bus	-	Active if the third (lower) fiber optic port of the CPU module has an active connection
RJ45/EOB on front panel	-	Active if the front RJ45 port (or EOB) has an active connection

Table 2-2 The measured analogue values of the ethernet links function

2.2.5.2.2.3. Events

The following events are generated in the event list, as well as sent to SCADA according to the configuration.

EVENT	VALUE	EXPLANATION
Station Bus1	off, on	Active if the first (upper) fiber optic port of the CPU module has an active connection.
Station Bus2 – Fiber	off, on	Active if the second (middle) fiber optic port of the CPU module has an active connection.
Station Bus2 –RJ4	off, on	Active if the RJ45 port of the CPU module has an active connection.
Process Bus	off, on	Active if the third (lower) fiber optic port of the CPU module has an active connection
RJ45/EOB on front panel	off, on	Active if the front RJ45 port (or EOB) has an active connection

Table 2-3 Events of the ethernet links function

2.2.5.2.3. Technical data

There is no technical data to add.

2.2.6. Trip Circuit Supervision

2.2.6.1. Introduction

This document describes the applicable hardware and provides guidelines for usage in the device configuration.

2.2.6.1.1. Operation principle

The trip circuit supervision is utilized for checking the integrity of the circuit between the trip coil and the tripping output of the protection device.

This is realized by injecting a small DC current (around 1-5 mA) into the trip circuit. If the circuit is intact, the current flows, causing an active signal to the opto coupler input of the trip contact.

The state of the input is shown on the devices' binary input listing among the other binary inputs, and it can be handled like any other of them (it can be added to the user logic, etc.)

2.2.6.1.2. Applicable modules

The following modules contain trip outputs with trip circuit supervision. The information here is restricted to the trip circuit supervision only. For more details please refer to the EuroProt+ Hardware description from which these were extracted. Note that there are other modules without trip circuit supervision, those are not listed here.

Table 1-1 Modules with Trip Circuit Supervision

MODULE TYPE	TRIP+4201	TRIP+2101	TRIP+2201	PSTP+4201	PSTP+2101
CHANNEL NUMBER	4	4	4	2	2
RATED VOLTAGE	24 V DC and 48 V DC	110 V DC	220 V DC	24 V DC and 48 V DC and 60 V DC	110 V DC and 220 V DC
THERMAL WITHSTAND VOLTAGE	72 V DC	150 V DC	242 V DC	72 V DC	242 V DC

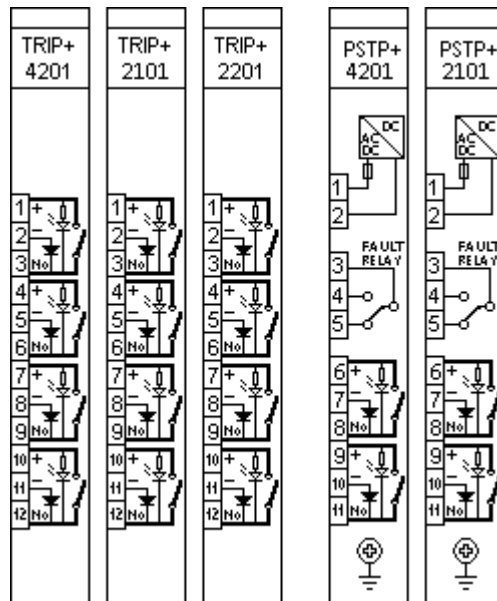

Figure 1-1 I/O arrangement of the modules with TCS

2.2.6.2. Hardware application

2.2.6.2.1. Wiring

The wiring of these modules can be 2-wire or 3-wire. The TCS – Trip Circuit Supervision function is active with both methods.



The voltage of the "No" contact is maximized at 15 V by a Zener-diode. Make sure that the voltage caused by the resistance of the circuit breaker and the injected current from the TRIP+ module does not reach 10 V. In case of PSTP+ modules, this voltage is 8 V (PSTP+/4201) and 13 V (PSTP+/2101).



Our TRIP+ modules are made to switch DC circuits. **Using reversed polarity or AC voltage can cause the damage of the internal circuits.**

2.2.6.2.1.1. 3-wire TRIP+ wiring methods

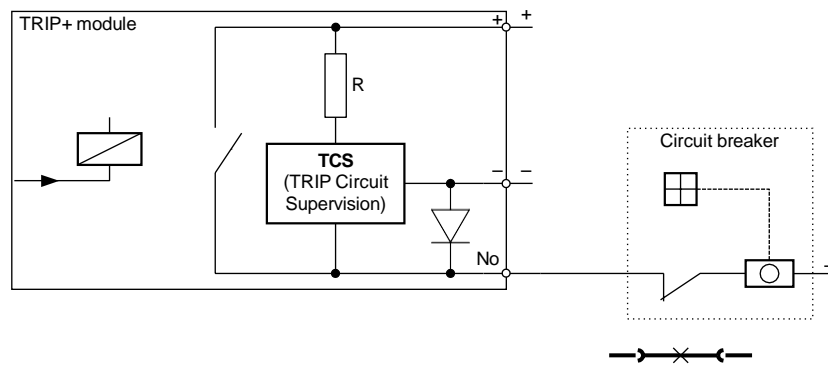

Figure 2-1 3-wire TRIP+ wiring

It is possible to use parallel connected TRIP+ modules. In this case the negative contacts must be common.

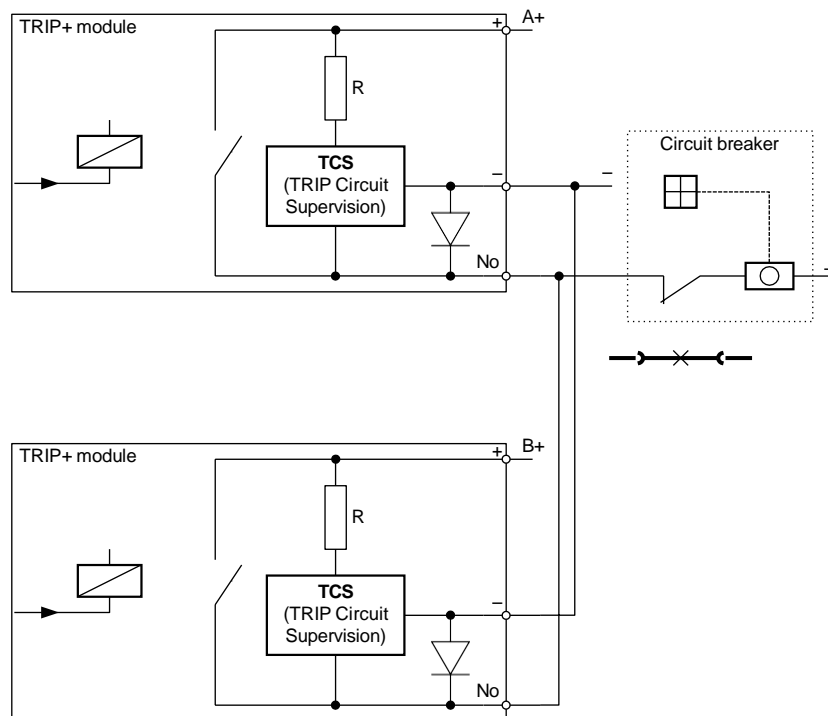

Figure 2-2 3-wire TRIP+ wiring using parallel connected TRIP+ modules

2.2.6.2.1.2. 2-wire TRIP+ wiring methods

If it is necessary, you can also wire the TRIP+ modules using only the “+” and the “No” contacts.

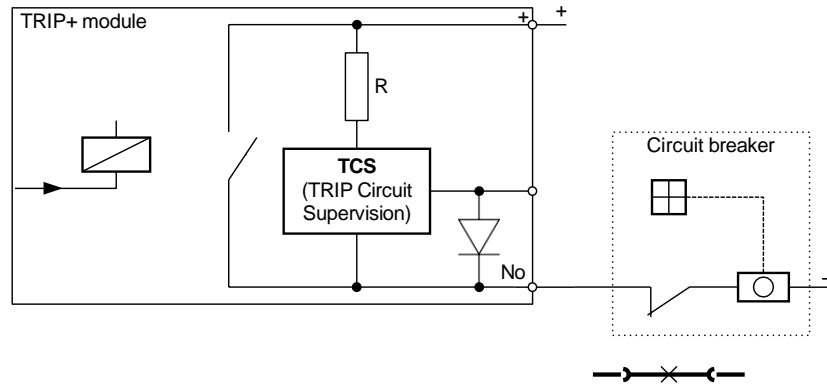

Figure 2-3 2-wire TRIP+ wiring

It is possible to use parallel connected TRIP+ modules.

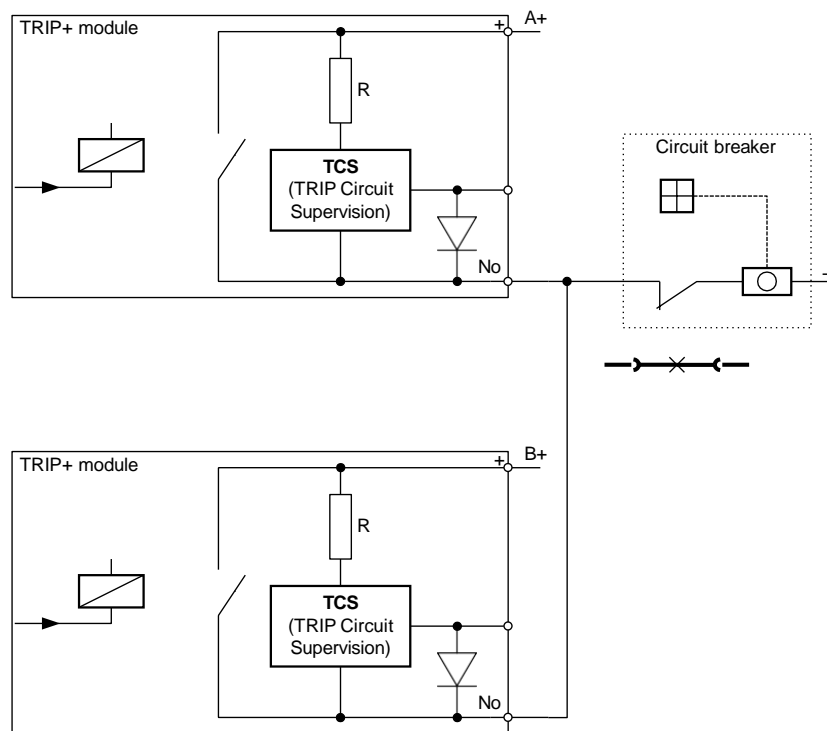

Figure 2-4 2-wire TRIP+ wiring using parallel connected TRIP+ modules

If the circuit breaker needs two-pole switching, TRIP+ modules can be connected series as you can see in [Figure 2-5](#).

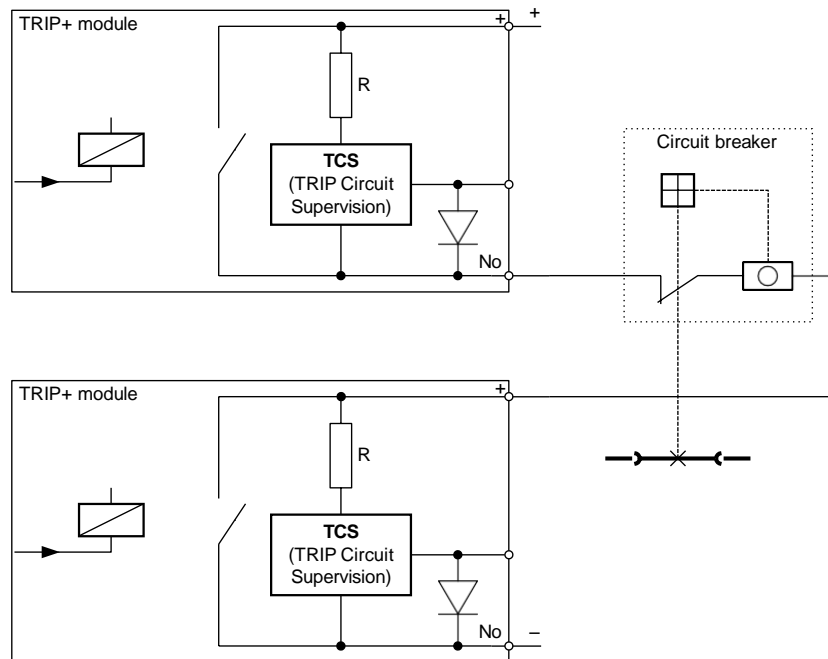

Figure 2-5 2-wire TRIP+ wiring using series connected TRIP+ modules

2.2.6.2.2. TCS signal handling

The Trip Circuit Supervision detects broken trip circuit if the current flowing through the trip coil is below 1 mA or (in case of 3-wire wirings) the voltage on it is above 8-10-13 V (depending on the module).

In Chapter [2.3](#) there are calculated maximum values for the resistance of the trip coil. If these values are exceeded, the TCS might consider the trip circuit broken even if it is intact.

To solve this, there are two ways:

- a) **Using the 2-wire wiring method***: leaving out/disconnecting the DC- part of the TRIP wiring may solve the issue.
Note that in this case the voltage is not maximized on 15 V, so **the used voltage (up to 220 Vdc) will appear on the “NO” pin**. Caution is advised when touching the wiring in this case.
- b) **Usage of modules without TCS**: if the TCS is not a requirement (e.g. in backup protections), it can be simply left out by opting for the appropriate modules (such as PSTP+/2131 or TRIP+/21F1) while ordering.

**The inputs of some relay testers might sense the states of the Trip contacts active even if they are not. In such cases the “-“ pin must be wired in for the tests.*



2.2.6.2.3. Technical data

The following tables contain information according to the wiring connections described in Chapter 2.1.

Table 2-1 Technical data for the TRIP+ modules

MODULE TYPE	TRIP+4201	TRIP+2101	TRIP+2201	
VALUE OF R RESISTOR ($\pm 10\%$)	10 k Ω	73 k Ω	130 k Ω	
INJECTED CURRENT AT "NO" CONTACT	2.4 mA @ 24 V DC 4.8 mA @ 48 V DC	1.5 mA @ 110 V DC	1.7 mA @ 220 V DC	
MAXIMUM RESISTANCE OF THE TRIP COIL	3-WIRE WIRING (MAX. 10 V)	11.8 k Ω @ 24 V DC 3.7 k Ω @ 48 V DC	9.7 k Ω @ 110 V DC 8.4 k Ω @ 125 V DC	8.1 k Ω @ 220 V DC
	3-WIRE WIRING WITH IN PARALLEL (MAX. 10 V)	5.9 k Ω @ 24 V DC 1.8 k Ω @ 48 V DC	4.8 k Ω @ 110 V DC 4.2 k Ω @ 125 V DC	4 k Ω @ 220 V DC
	2-WIRE METHOD (1 mA MIN. CURRENT)	14 k Ω @ 24 V DC 38 k Ω @ 48 V DC	37 k Ω @ 110 V DC 52 k Ω @ 125 V DC	90 k Ω @ 220 V DC

The PSTP+ modules work based on current generator principle, so the calculations for these are based on the necessary minimum current and the allowed maximum voltage.

Table 2-2 Technical data for the PSTP+ modules

MODULE TYPE	PSTP+4201	PSTP+2101	
INJECTED CURRENT AT "NO" CONTACT	1.5 mA	1.5 mA	
MAXIMUM RESISTANCE OF THE TRIP COIL	3-WIRE WIRING (1 mA CURRENT)	8 k Ω (max. 8 V)	13 k Ω (max. 13 V)
	3-WIRE WIRING IN PARALLEL	4 k Ω (max. 8 V)	6.5 k Ω (max. 13 V)
	2-WIRE METHOD (1 mA MIN. CURRENT)	24 k Ω @ 24 V DC 48 k Ω @ 48 V DC 60 k Ω @ 60 V DC	110 k Ω @ 110 V DC 220 k Ω @ 220 V DC

2.2.6.3. Software application

2.2.6.3.1. Binary inputs



The **TCS input is active if the trip circuit is intact**, so the logical '0' or FALSE signal of the input means that either the trip circuit is broken, or it connects to high resistance.

The TCS signals are shown the same way as other binary inputs are in the device: they can be seen in the **on-line data** menu on the local HMI or the device web page, and they can be utilized just like any other binary input when editing the device configuration with EuroCAP software.

The names/titles of the inputs follow the occupied slot of the TRIP module (if it is in Slot **N**, the TCS contact is named BIn_#N##).

2.2.6.3.2. The TCS macro

In most cases the trip circuit is tripped along with the circuit breaker as well. In situations like this the TCS input would signal a broken trip circuit (logical '0' or FALSE) unnecessarily. To avoid this, the status signals of the CB are to be used combined with the TCS input signal so that it will be evaluated only when the CB is closed.

The TCS macro incorporates this logic for two separate TCS inputs for one CB (see [Figure 3-2](#) for the two TCS inputs and the CB status signal inputs). The outputs are the failure signals for each connected TCS input.

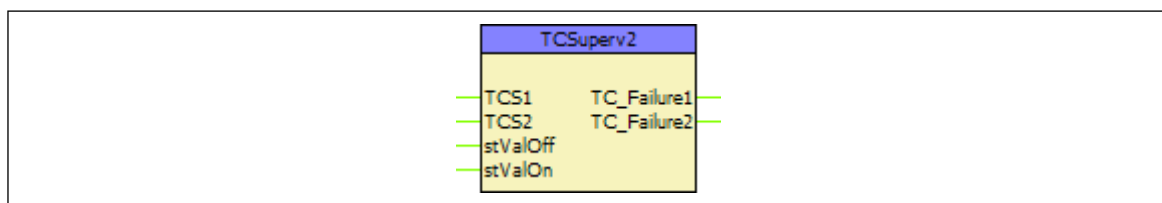

Figure 3-1 Graphic appearance of the Trip Circuit Supervision macro



The internal logic of the macro can be seen on [Figure 3-2](#) below. Both outputs have a fixed pick delay of 1000 ms. Note that **here the outputs are active if the trip circuit is broken**. For a CB with only 1 trip circuit it is enough to simply leave the **TCS2** input open (naturally in this case the TC_Failure2 output cannot be used).

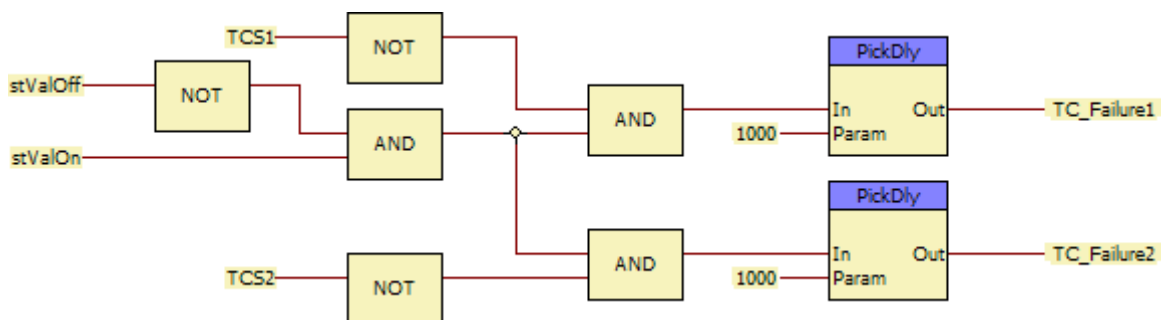

Figure 3-2 Internal logic of the Trip Circuit Supervision macro

2.2.6.3.2.1. Binary input signals

The following table explains the binary input signals of the macro.

Table 3-1 Binary input signals of the Trip Circuit Supervision macro

BINARY INPUT SIGNAL	EXPLANATION
TCS1	Connect here the first TCS binary input
TCS2	Connect here the second TCS binary input
stValOff	CB Off/Open signal
stValOn	CB On/Closed signal

2.2.6.3.2.2. Binary output signals

The following table explains the binary output signals of the macro.

Table 3-2 Binary output signals of the Trip Circuit Supervision macro

BINARY OUTPUT SIGNAL	EXPLANATION
TC_Failure1	Failure on the first circuit
TC_Failure2	Failure on the second circuit

Note that these are the outputs of a macro, and not a function block, so they must be connected to a physical or a logical output (ConnOut, create status) to make them usable in other parts of the configuration. For further information please refer to the EuroCAP software description.

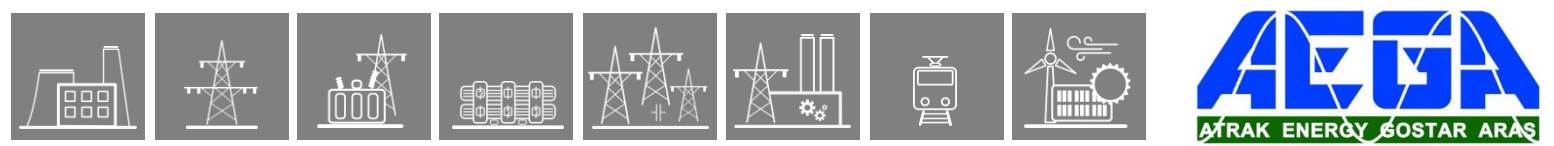

2.2.7. Dead Line Detection Function

2.2.7.1. Application

The “Dead Line Detection” (DLD) function generates a signal indicating the dead or live state of the line. Additional signals are generated to indicate if the phase voltages and phase currents are above the pre-defined limits.

2.2.7.1.1. Mode of Operation

The task of the “Dead Line Detection” (DLD) function is to decide the Dead line/Live line state.

Criteria of “Dead line” state: all three phase voltages are below the voltage setting value AND all three currents are below the current setting value.

Criteria of “Live line” state: all three phase voltages are above the voltage setting value.

2.2.7.1.2. Structure of the Algorithm

Figure 1-1 shows the structure of the dead line detection algorithm.

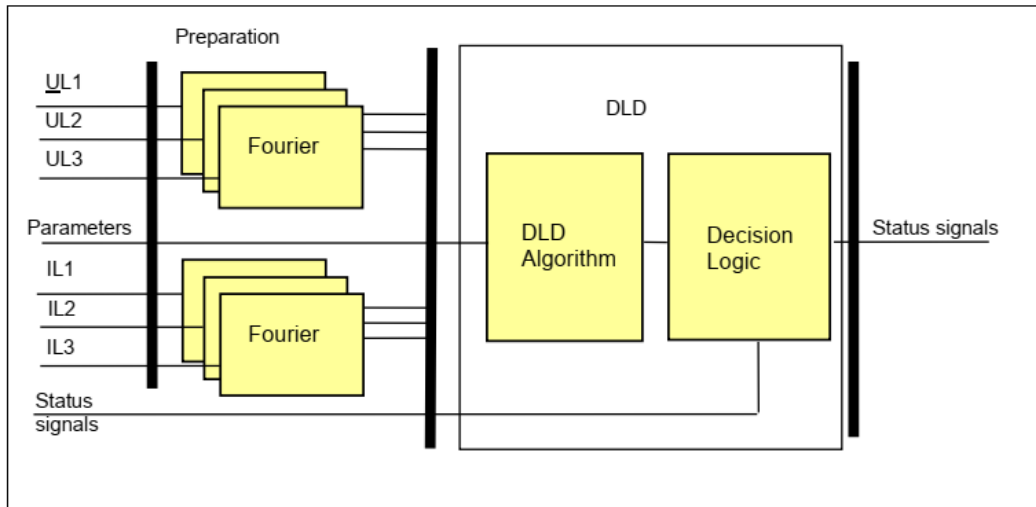

Figure 1-1 Structure of the dead line detection algorithm

For the preparation phase:

The **inputs** are

- the sampled values of the three phase voltages (UL1, UL2, UL3) and three phase currents (IL1, IL2, IL3),
- parameters.

The **outputs** are

- the fundamental Fourier components of the three phase voltages (UL1, UL2, UL3) and three phase currents (IL1, IL2, IL3).

For the DLD function:

The **inputs** are

- the fundamental Fourier components of the three phase voltages (UL1, UL2, UL3) and three phase currents (IL1, IL2, IL3),
- parameters,
- status signals.

The **software modules** of the dead line detection function are:

Fourier calculations

These modules calculate the basic Fourier components of the phase currents and phase voltages individually. These modules belong to the preparation phase.

Dead Line Detection

This module decides if the “Live line condition” (Line_OK) or the “DeadLine condition” is fulfilled.

Decision logic

The decision logic module combines the status signals to generate the outputs of the function.

The following description explains the details of the individual components.

2.2.7.1.3. The Fourier Calculation (Fourier)

These modules calculate the basic Fourier current components of the phase voltages and phase currents individually. These modules belong to the preparation phase.

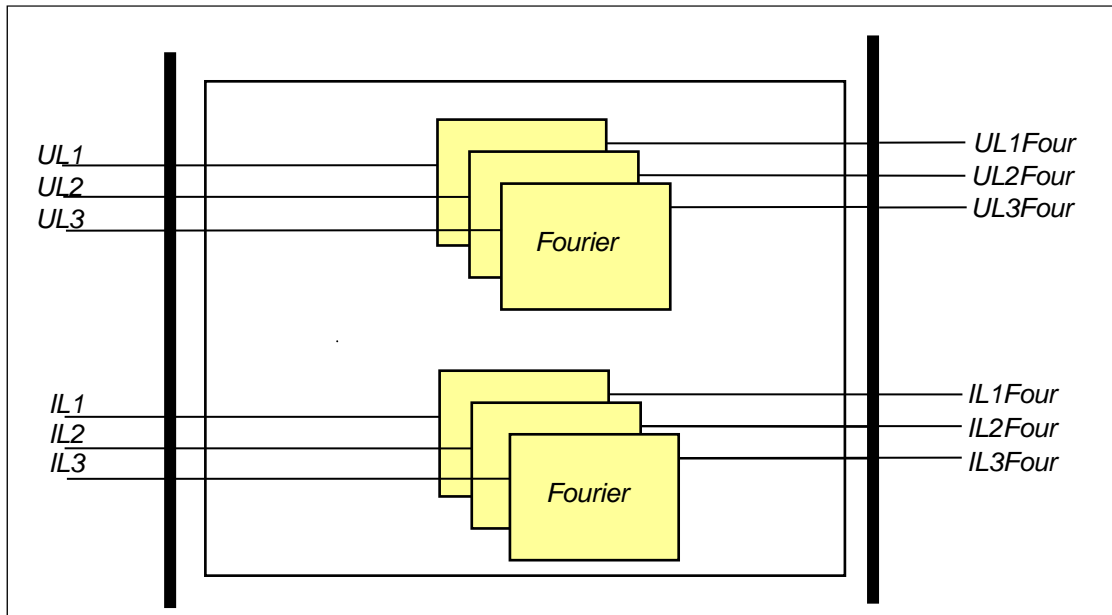

Figure 1-2 Principal scheme of the Fourier calculation

The **inputs** are the sampled values of:

- the three phase voltages (UL1, UL2, UL3)
- the three phase currents (IL1, IL2, IL3)

The **outputs** are:

- the basic Fourier components of the analyzed voltages (UL1Four, UL2Four, UL3Four),
- the basic Fourier components of the analyzed currents (IL1Four, IL2Four, IL3Four).

2.2.7.1.4. The Dead Line Detection Algorithm (Dead Line Detection)

This module decides if the “Live line condition” (Line_OK) or the “DeadLine condition” is fulfilled.

The **inputs** are

- the basic Fourier components of the phase voltages (UL1Four, UL2Four, UL3Four),
- the basic Fourier components of the phase currents (IL1Four, IL2Four, IL3Four),
- status signals,
- parameters.

The **outputs** are the internal status signals of the function. These indicate the “DeadLine condition” or the “Live line condition” (Line_OK) state.

Criteria of “Dead line” state: all three phase voltages are below the voltage setting value AND all three currents are below the current setting value.

Criteria of “Live line” state: all three phase voltages are above the voltage setting value.

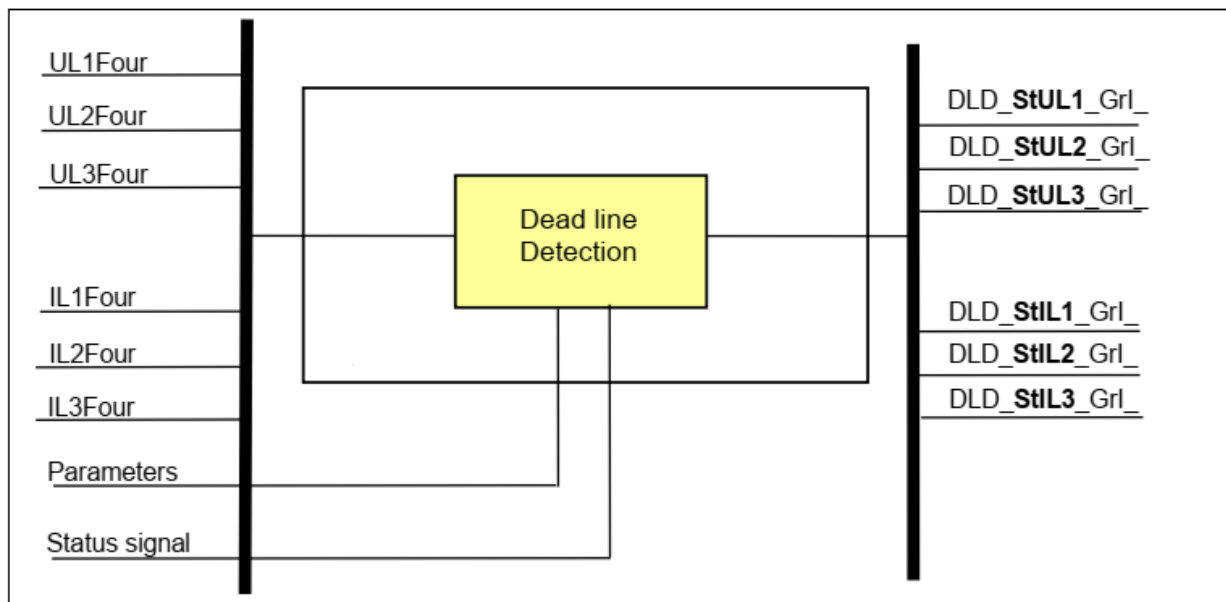

Figure 1-3 Principal scheme of the dead line detection function

Enumerated parameters

Table 1-1 The enumerated parameters of the dead line detection function

TITLE	DIM	RANGE	STEP	DEFAULT	EXPLANATION
Operation	-	Off, On	-	Off	Parameter for enabling the function

Integer parameters

Table 1-2 The integer parameters of the dead line detection function

TITLE	DIM	RANGE	STEP	DEFAULT	EXPLANATION
Min Operate Voltage	%	10 – 100	1	60	Voltage setting for “Dead line” state criteria.
Min Operate Current	%	2 – 100	1	10	Current setting for “Dead line” state criteria.

Binary status signals

The dead line detection function has a binary input signal, which serves the purpose of disabling the function. **The conditions of disabling are defined by the user, applying the graphic equation editor.**

Table 1-3 The binary input signal of the dead line detection function

BINARY STATUS SIGNAL	SIGNAL TITLE	EXPLANATION
DLD_Blk_GrO_	Block	Input used to disable the function

The **binary output status signals** of the residual dead line detection function are listed in [Table 1-4](#).

Table 1-4 The binary output status signals of the dead line detection function

BINARY OUTPUT SIGNAL	SIGNAL TITLE	EXPLANATION
DLD_StUL1_Grl_	Start UL1	The voltage of phase L1 is above the setting limit
DLD_StUL2_Grl_	Start UL2	The voltage of phase L2 is above the setting limit
DLD_StUL3_Grl_	Start UL3	The voltage of phase L3 is above the setting limit
DLD_StIL1_Grl_	Start IL1	The current of phase L1 is above the setting limit
DLD_StIL2_Grl_	Start IL2	The current of phase L2 is above the setting limit
DLD_StIL3_Grl_	Start IL3	The current of phase L3 is above the setting limit

2.2.7.1.5. The Decision Logic (Decision logic)

The decision logic module combines status signals, binary and enumerated parameters to generate the dead line or live line status signals.

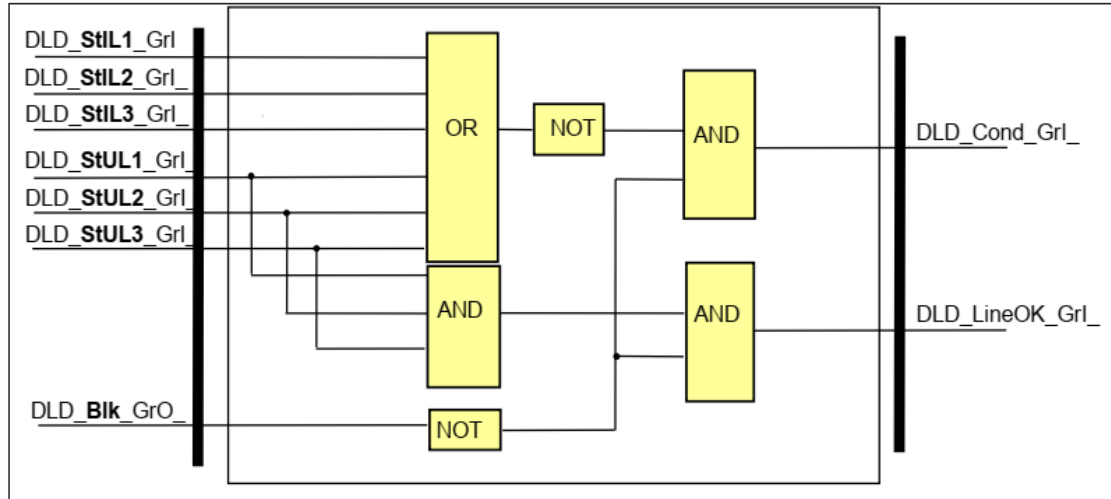

Figure 1-4 The logic scheme of the decision logic

Table 1-5 The binary input status signal of the decision logic

BINARY INPUT SIGNAL	SIGNAL TITLE	EXPLANATION
DLD_StUL1_Grl_	Start UL1	The voltage of phase L1 is above the setting limit
DLD_StUL2_Grl_	Start UL2	The voltage of phase L2 is above the setting limit
DLD_StUL3_Grl_	Start UL3	The voltage of phase L3 is above the setting limit
DLD_StIL1_Grl_	Start IL1	The current of phase L1 is above the setting limit
DLD_StIL2_Grl_	Start IL2	The current of phase L2 is above the setting limit
DLD_StIL3_Grl_	Start IL3	The current of phase L3 is above the setting limit

Binary status signals

The function has a binary input signal, which serves the purpose of disabling the function. **The conditions of disabling are defined by the user, applying the graphic equation editor.**

Table 1-6 The binary input signal of the dead line detection function

BINARY STATUS SIGNAL	SIGNAL TITLE	EXPLANATION
DLD_Blk_GrO_	Block	Input for disabling the function

Table 1-7 The binary output status signals of the dead line detection function

BINARY OUTPUT SIGNAL	SIGNAL TITLE	EXPLANATION
DLD_DeadLine_Grl_	DeadLine condition	The requirements of "DeadLine condition" are fulfilled
DLD_LineOK_Grl_	LineOK condition	The requirements of "Live line condition" (LineOK) are fulfilled

2.2.7.2. DeadLine Detection Function Overview

The graphic appearance of the dead line detection function block is shown in [Figure 2-1](#). This block shows all binary input and output status signals that are applicable in the graphic equation editor.

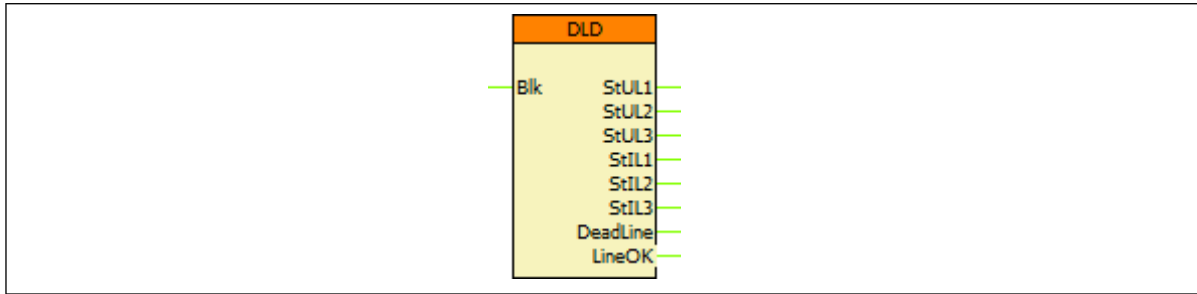

Figure 2-1 The function block of the residual instantaneous overcurrent protection

2.2.7.2.1. Settings

2.2.7.2.1.1. Parameters

The available parameters are listed below in order of their appearance in the *parameters* menu. If the setting range of a parameter should be extended, contact Protecta Support.

Table 2-1 Parameters of the dead line detection function

TITLE	DIM	RANGE	STEP	DEFAULT	EXPLANATION
Operation	-	Off, On	-	Off	Parameter for enabling the function
Min Operate Voltage	%	10 – 100	1	60	Voltage setting for “Dead line” state criteria.
Min Operate Current	%	2 – 100	1	10	Current setting for “Dead line” state criteria.

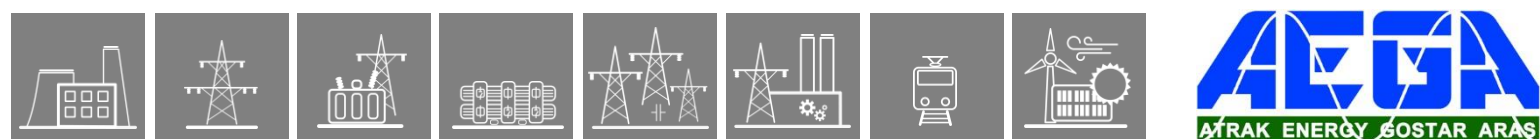

2.2.7.2.2. Function I/O

This section briefly describes the analogue and digital inputs and outputs of the function block.

2.2.7.2.2.1. Analogue inputs

The analog inputs are the sampled values of the three phase voltages and the three phase currents.

2.2.7.2.2.2. Binary input signals (graphed output statuses)

The conditions of the binary inputs are defined by the user, applying the graphic equation editor (*Logic Editor*). Parts written in **bold** are seen on the left side of the function block in the Logic editor.

Table 2-2 The binary input signals of the dead line detection function

BINARY INPUT SIGNAL	SIGNAL TITLE	EXPLANATION
DLD_ Blk _GrO_	Block	Input for disabling the function

2.2.7.2.2.3. Binary output signals (graphed input statuses)

These signals can be used in EuroCAP to assign to LED, user LCD object etc. Parts written in **bold** are seen on the right side of the function block in the *Logic Editor*.

Table 2-3 The binary output signals of the dead line detection function

BINARY OUTPUT SIGNAL	SIGNAL TITLE	EXPLANATION
DLD_ StUL1 _GrI_	Start UL1	The voltage of phase L1 is above the setting limit
DLD_ StUL2 _GrI_	Start UL2	The voltage of phase L2 is above the setting limit
DLD_ StUL3 _GrI_	Start UL3	The voltage of phase L3 is above the setting limit
DLD_ StIL1 _GrI_	Start IL1	The current of phase L1 is above the setting limit
DLD_ StIL2 _GrI_	Start IL2	The current of phase L2 is above the setting limit
DLD_ StIL3 _GrI_	Start IL3	The current of phase L3 is above the setting limit
DLD_ DeadLine _GrI_	DeadLine condition	The requirements of "DeadLine condition" are fulfilled
DLD_ LineOK _GrI_	LineOK condition	The requirements of "Live line condition" (LineOK) are fulfilled

2.2.7.2.2.4. Online data

The following values are visible in the *online data* page.

Table 2-4 Online data of the dead line detection function

SIGNAL TITLE	DIMENSION	EXPLANATION
DeadLine condition	-	The requirements of "DeadLine condition" are fulfilled
LineOK condition	-	The requirements of "Live line condition" are fulfilled

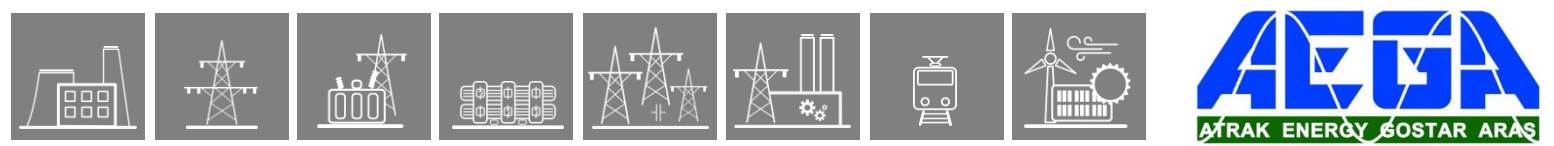

2.2.7.2.2.5. Events

There are no events generated for this function block.

2.2.7.2.3. Technical Data

Table 2-5 Technical data of the dead line detection function

FUNCTION	VALUE	ACCURACY
Pick-up voltage		1%
Operation time	< 20 ms	
Reset ratio	0.95	

2.2.7.2.4. Notes for Testing

This function does not generate events on its own. To create them, another function block, the GGIO16 custom event function block must be utilized, see its description for more information.

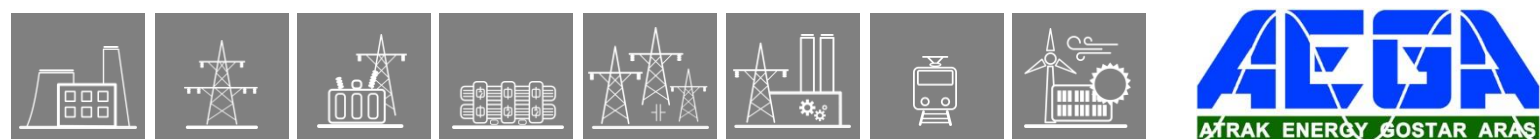

2.2.8. Voltage transformer supervision function

The voltage transformer supervision function generates a signal to indicate an error in the voltage transformer secondary circuit. This signal can serve, for example, as a warning, indicating disturbances in the measurement, or it can disable the operation of the distance protection function if appropriate measured voltage signals are not available for a distance decision.

The voltage transformer supervision function is designed to detect faulty asymmetrical states of the voltage transformer circuit caused, for example, by a broken conductor in the secondary circuit.

(Another method for detecting voltage disturbances is the supervision of the auxiliary contacts of the miniature circuit breakers in the voltage transformer secondary circuits. This function is not described here.)

The user has to generate graphic equations for the application of the signal of this voltage transformer supervision function.

This function is interconnected with the “dead line detection function”. Although the dead line detection function is described fully in a separate document, the explanation necessary to understand the operation of the VT supervision function is repeated also in this document.

2.2.8.1. Mode of operation

2.2.8.1.1. “Dead line detection” (DLD) function - modes of operation

The voltage transformer supervision function is based on the “Dead line detection” (DLD) function, the task of which is to decide the Dead line/Live line state.

Criteria of “Dead line” state: all three phase voltages are below the preset voltage value AND all three currents are below the preset current value.

Criteria of “Live line” state: all three phase voltages are above the preset voltage value.

The dead line detection function is described in a separate document.

2.2.8.1.2. “Voltage transformer supervision” (VTS) function - modes of operation

The voltage transformer supervision function can be used in three different modes of application:

Zero sequence detection (for typical applications in systems with grounded neutral): “VT failure” signal is generated if the residual voltage ($3U_0$) is above the preset voltage value AND the residual current ($3I_0$) is below the preset current value.

Negative sequence detection (for typical applications in systems with isolated or resonant grounded (Petersen) neutral): “VT failure” signal is generated if the negative sequence voltage component (U_2) is above the preset voltage value AND the negative sequence current component (I_2) is below the preset current value.

Special application: “VT failure” signal is generated if the residual voltage ($3U_0$) is above the preset voltage value AND the residual current ($3I_0$) AND the negative sequence current component (I_2) are below the preset current values.

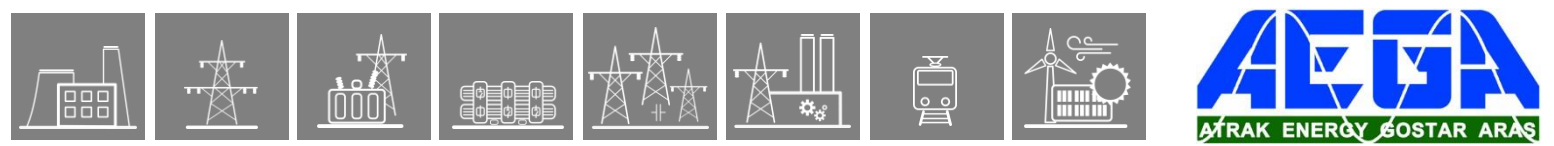

2.2.8.1.3. Activating the VTS function

The voltage transformer supervision function can be activated if “Live line” status is detected for at least 200 ms. This delay avoids mal-operation at line energizing if the poles of the circuit breaker make contact with a time delay. The function is set to be inactive if “Dead line” status is detected.

If the conditions specified by the selected mode of operation are fulfilled (for at least 4 milliseconds) then the voltage transformer supervision function is activated and the operation signal is generated. (When evaluating this time delay, the natural operating time of the applied Fourier algorithm must also be considered.)

NOTE: For the operation of the voltage transformer supervision function the “Dead line detection function” must be operable as well: it must be enabled by binary parameter setting, and its blocking signal may not be active.

2.2.8.1.4. Resetting the VTS function

If, in the active state, the conditions for operation are no longer fulfilled, the resetting of the function depends on the mode of operation of the primary circuit:

- If the “Live line” state is valid, then the function resets after approx. 200 ms of time delay. (When evaluating this time delay, the natural operating time of the applied Fourier algorithm must also be considered.)
- If the “Dead line” state is started and the “VTS Failure” signal has been continuous for at least 100 ms, then the “VTS failure” signal does not reset; it is generated continuously even when the line is in a disconnected state. Thus, the “VTS Failure” signal remains active at reclosing.
- If the “Dead line” state is started and the “VTS Failure” signal has not been continuous for at least 100 ms, then the “VTS failure” signal resets.

2.2.8.2. Structure of the voltage transformer supervision algorithm

Fig.1-1 shows the structure of the voltage transformer supervision (VTS) algorithm.

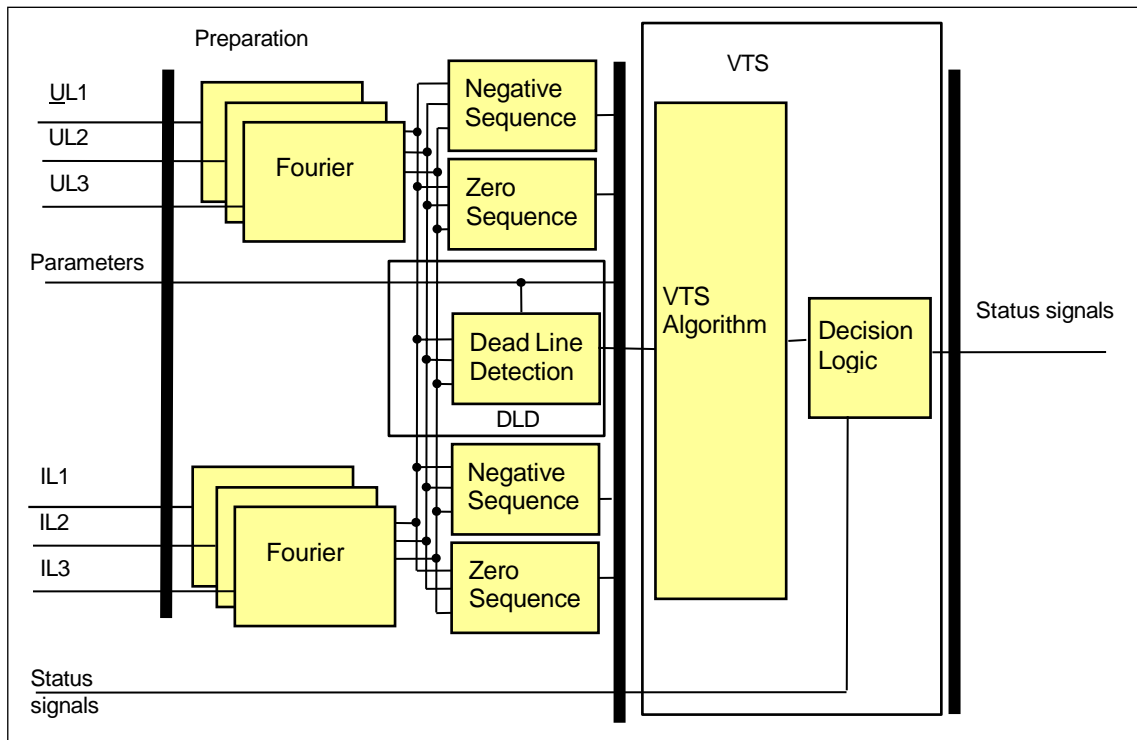

Figure 1-1 Structure of the voltage transformer supervision algorithm

For the preparation phase:

The **inputs** are

- the sampled values of the three phase voltages (UL1, UL2, UL3) and three phase currents (IL1, IL2, IL3),
- parameters.

The **outputs** are

- negative and zero sequence voltage and current components.
- signals indicating the “Live line” or “Dead line” condition.

For the VTS function:

The **inputs** are

- negative and zero sequence voltage and current components.
- signals indicating the “Live line” or “Dead line” condition,
- parameters,
- status signals.

The **outputs** are

- the binary output status signal indicating a failure of the voltage transformer secondary circuit,
- signals indicating the “Live line” or “Dead line” condition.

2.2.8.3. The Fourier calculation (Fourier)

These modules calculate the basic Fourier current components of the phase voltages and phase currents individually. These modules belong to the preparation phase.

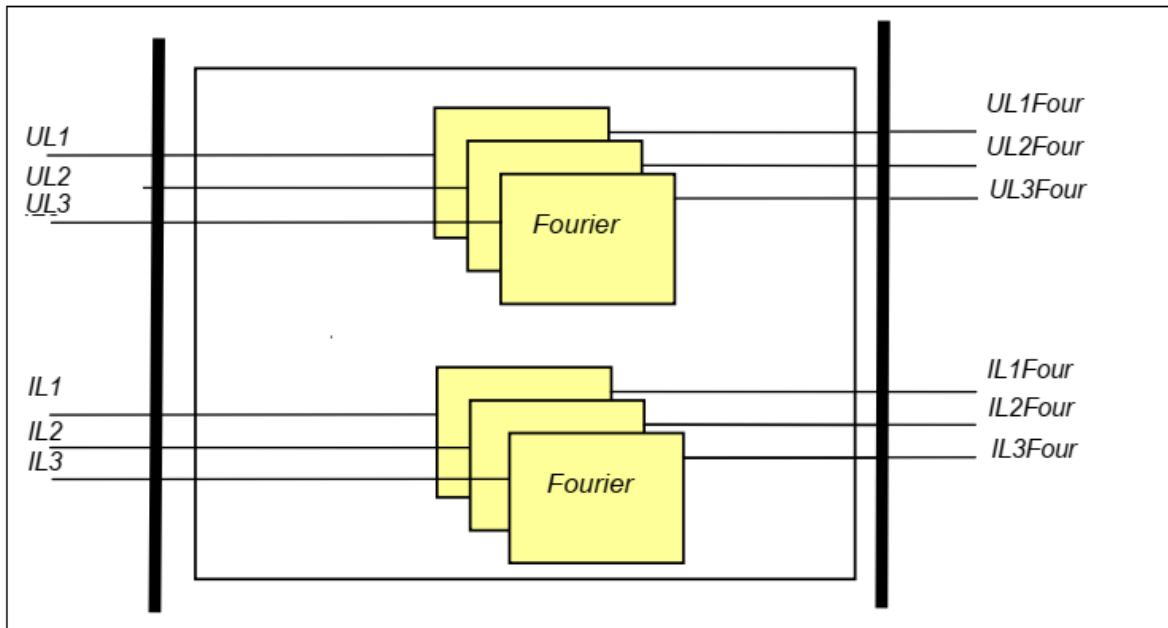

Figure 1-2 Principal scheme of the Fourier calculation

The **inputs** are the sampled values of:

- the three phase voltages (UL1, UL2, UL3)
- the three phase currents (IL1, IL2, IL3)

The **outputs** are

- the basic Fourier components of the analyzed voltages (UL1Four, UL2Four, UL3Four),
- the basic Fourier components of the analyzed currents (IL1Four, IL2Four, IL3Four).

2.2.8.4. The negative phase sequenc calculation (Negative sequence)

This module calculates the negative phase sequence components based on the Fourier components of the phase voltages and phase currents. These modules belong to the preparation phase.

The **inputs** are the basic Fourier components of the phase voltages and phase currents (UL1Four, UL2Four, UL3Four, IL1Four, IL2Four, IL3Four).

The **outputs** are

- the basic Fourier components of the negative sequence voltage component (UNegFour),
- the basic Fourier components of the negative sequence current component (INegFour).

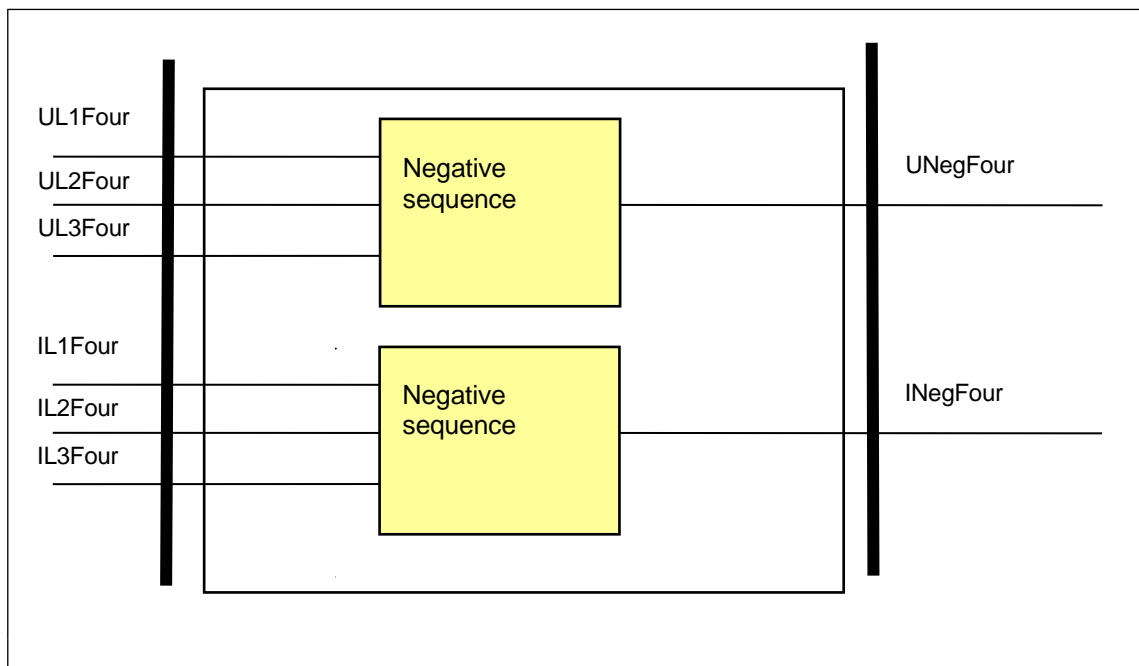

Figure 1-3 Schema of the negative sequence component calculation

2.2.8.5. The residual voltage and current calculation (Zero sequence)

This module calculates the residual voltage ($U_{ZerFour}$) and current ($I_{ZerFour}$) based on the Fourier components of the phase voltages and currents. These modules belong to the preparation phase.

The **inputs** are

- the basic Fourier components of the phase voltages ($UL1Four$, $UL2Four$, $UL3Four$),
- the basic Fourier components of the phase currents ($IL1Four$, $IL2Four$, $IL3Four$).

The **outputs** are

- the basic Fourier components of the residual voltage ($U_{ZerFour}$),
- the basic Fourier components of the residual current ($I_{ZerFour}$).

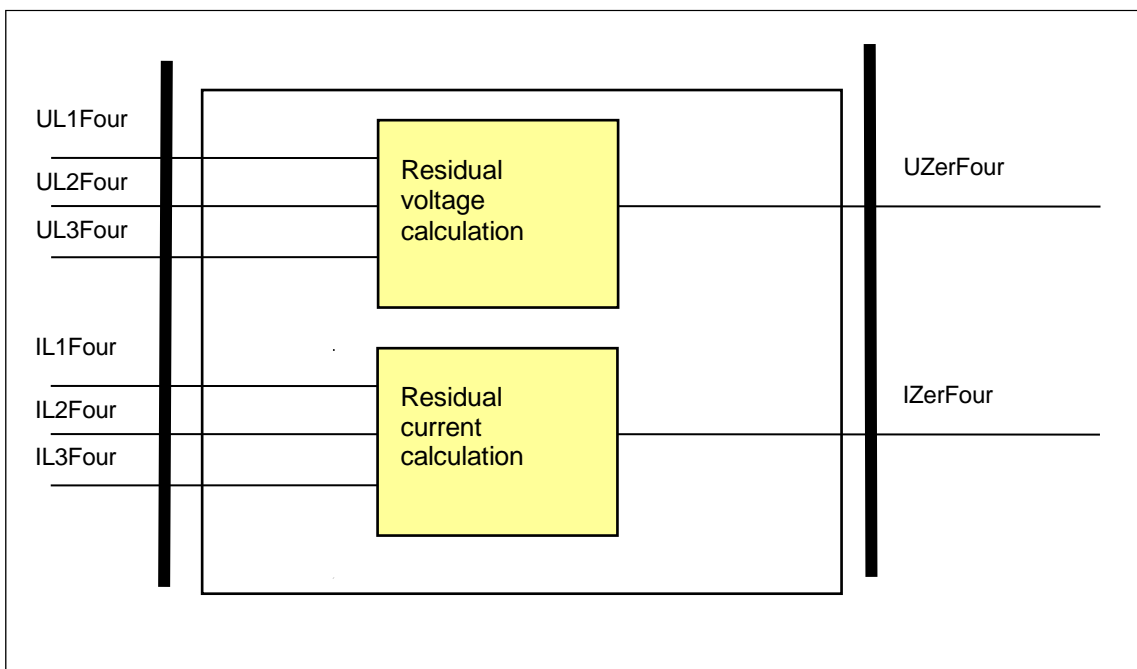

Figure 1-4 Schema of the residual voltage and current calculation

2.2.8.6. The dead line detection algorithm (Dead Line Detection)

This module decides if the “Line_OK condition” or the “DeadLine condition” is fulfilled. This module belongs to the preparation phase.

The **inputs** are

- the basic Fourier components of the phase voltages (UL1Four, UL2Four, UL3Four),
- the basic Fourier components of the phase currents (IL1Four, IL2Four, IL3Four),
- parameters.

The **outputs** are the internal status signals of the function. These indicate the “DeadLine condition state” or the “Line_OK conditions” state. This module belongs to the preparation phase.

Criteria of “Dead line” state: all three phase voltages are below the voltage setting value AND all three currents are below the current setting value.

Criteria of “Live line” state: all three phase voltages are above the voltage setting value.

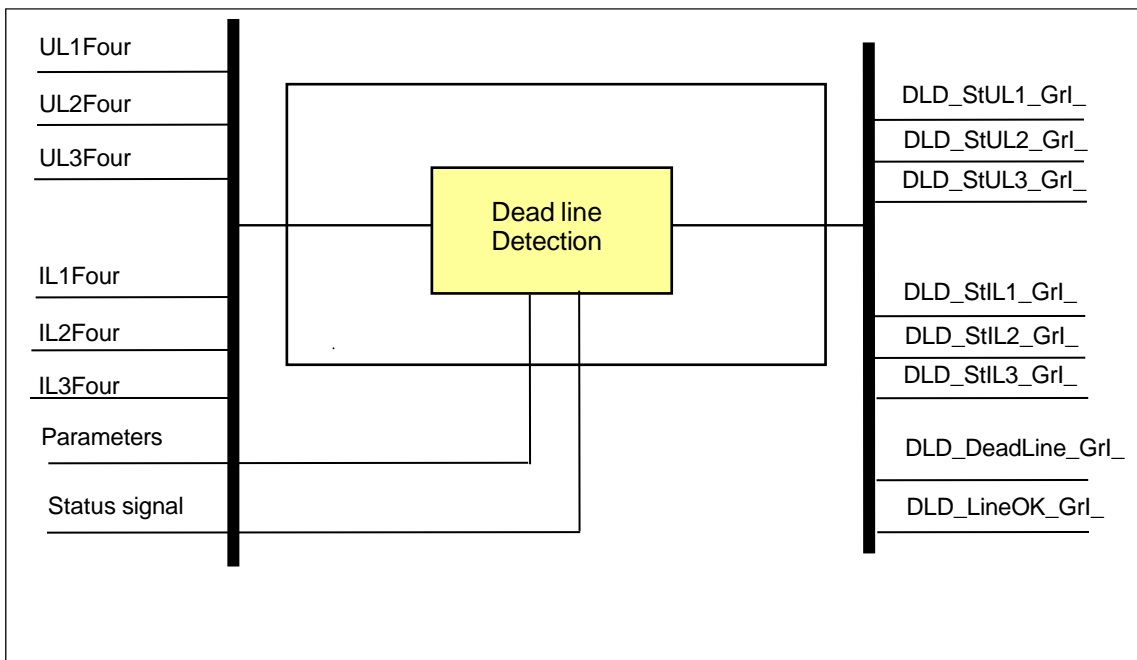

Figure 1-5 Principal scheme of the dead line detection function

The parameters of the dead line detection function are listed in [Table 1-1](#).

Integer parameters

Parameter name	Title	Unit	Min	Max	Step	Default
Integer parameters of the dead line detection function						
DLD_ULev_IPar_	Min Operate Voltage	%	10	100	1	60
DLD_ILev_IPar_	Min Operate Current	%	2	100	1	10

Table 1-1 The integer parameters of the dead line detection function

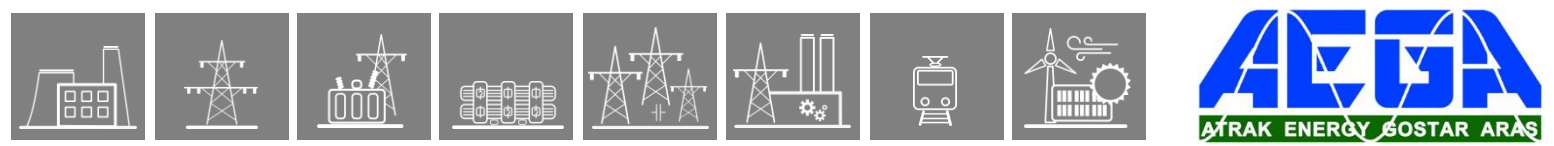

Binary status signals

The dead line detection function has a binary input signal, which serves the purpose of disabling the function. **The conditions of disabling are defined by the user, applying the graphic equation editor.**

Binary status signal	Explanation
DLD_Blk_GrO_	Output status of a graphic equation defined by the user to disable the dead line detection function.

Table 1-2 The binary input signal of the dead line detection function

The **binary output status signals** of the dead line detection function are listed in Table 1-3.

Binary output signals	Signal title	Explanation
DLD_StUL1_GrI_	Start UL1	The voltage of phase L1 is above the preset parameter value
DLD_StUL2_GrI_	Start UL2	The voltage of phase L2 is above the preset parameter value
DLD_StUL3_GrI_	Start UL3	The voltage of phase L3 is above the preset parameter value
DLD_StIL1_GrI_	Start IL1	The current of phase L1 is above the preset parameter value
DLD_StIL2_GrI_	Start IL2	The current of phase L2 is above the preset parameter value
DLD_StIL3_GrI_	Start IL3	The current of phase L3 is above the preset parameter value
DLD_DeadLine_GrI_	DeadLine condition	The criteria for dead line condition are fulfilled
DLD_LineOK_GrI_	LineOK condition	The criteria for line OK condition are fulfilled

Table 1-3 The binary output status signals of the dead line detection function

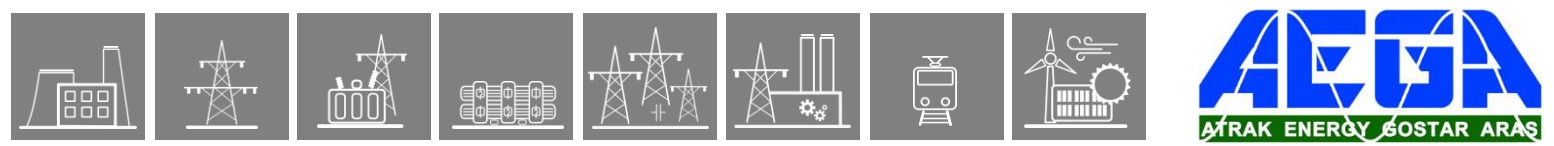

2.2.8.7. Voltage transformer supervision (VTS algorithm)

The voltage transformer supervision function can be used in three different modes of operation:

Zero sequence detection (for typical applications in systems with grounded neutral): “VT failure” signal is generated if the residual voltage ($3U_0$) is above the preset voltage value AND the residual current ($3I_0$) is below the preset current value.

Negative sequence detection (for typical applications in systems with isolated or resonant grounded (Petersen) neutral): “VT failure” signal is generated if the negative sequence voltage component (U_2) is above the preset voltage value AND the negative sequence current component (I_2) is below the preset current value.

Special application: “VT failure” signal is generated if the residual voltage ($3U_0$) is above the preset voltage value AND the residual current ($3I_0$) AND the negative sequence current component (I_2) are below the preset current values.

The task of this module is to detect if the conditions of the “VTS FAIL” state are fulfilled, according to the conditions defined for the selected mode of operation.

The **inputs** are

- the basic Fourier components of the residual voltage ($UZerFour$) and current ($IZerFour$),
- the negative sequence components of the voltage ($UNegFour$) and current ($INegFour$),
- binary signals from the dead line detection function,
- parameters.

NOTE: For the operation of the voltage transformer supervision function the “Dead line detection function” must be operable as well: it must be enabled by binary parameter setting, and its blocking signal may not be active.

The **output** is the internal status signal of the function. This internal signal indicates if the “VTS_FAIL_int” condition is fulfilled.

Binary output signals	Signal title	Explanation
VTS_FAIL_int	VTS_FAIL_int	Internal status signal indicating the fulfillment of conditions. This status signal is not available for the users.

Table 1-4 The binary internal status signals of the voltage transformer supervision algorithm

The parameters of the voltage transformer supervision algorithm are listed in [Table 1-5](#) and in [Table 1-6](#).

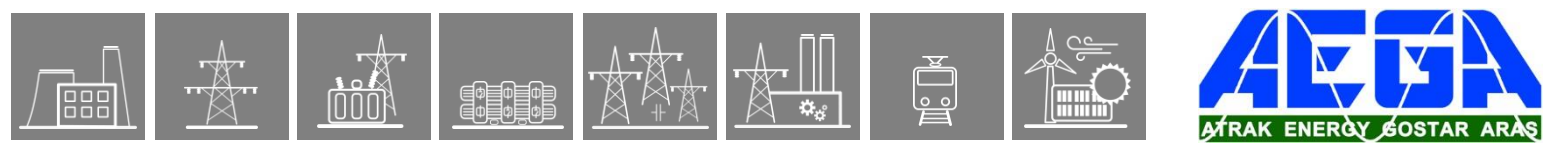

Enumerated parameter

Parameter name	Title	Selection range	Default
Parameter for type selection			
VTS_Oper_EPar_	Operation	Off, Zero sequence, Neg sequence, Special	Zero sequence

Table 1-5 The enumerated parameters of the voltage transformer supervision function

Integer parameters

Parameter name	Title	Unit	Min	Max	Step	Default
Starting voltage and current parameter for residual and negative sequence detection:						
VTS_Uo_IPar_	Start URes	%	5	50	1	30
VTS_Io_IPar_	Start IRes	%	10	50	1	10
VTS_Uneg_IPar_	Start UNeg	%	5	50	1	10
VTS_Ineg_IPar_	Start INeg	%	10	50	1	10

Table 1-6 The integer parameters of the voltage transformer supervision algorithm

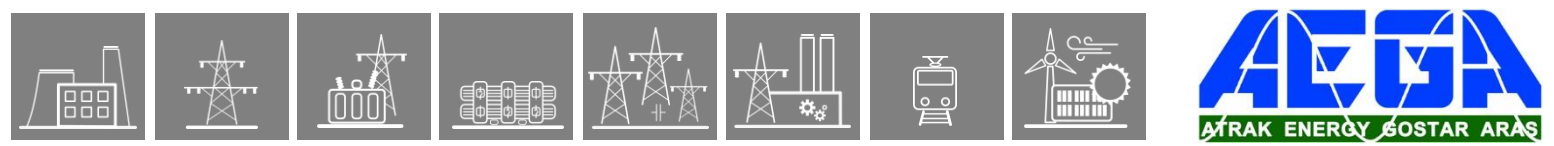

Binary status signals

The voltage transformer supervision function has a binary input signal, which serves the purpose of disabling the function. **The conditions of disabling are defined by the user, applying the graphic equation editor.**

Binary status signal	Explanation
VTS_BlK_GrO_	Output status of a graphic equation defined by the user to disable the voltage transformer supervision function.

Table 1-8 The binary input signal of the decision logic

Binary output signals	Signal title	Explanation
DLD_DeadLine_GrI_	DeadLine condition	The requirements of “DeadLine condition” are fulfilled
DLD_LineOK_GrI_	LineOK condition	The requirements of “LineOK condition” are fulfilled
VTS_Fail_GrI	VT Failure	Failure status signal of the VTS function

Table 1-9 The binary output status signals of the decision logic

2.2.8.9. Technical summary

2.2.8.9.1. Technical data

Function	Value	Accuracy
Pick-up voltage I ₀ =0A I ₂ =0A		<1% <1%
Operation time	<20ms	
Reset ratio	0.95	

Table 1-10 Technical data of the voltage transformer supervision function

2.2.8.9.2. The parameters

Integer parameters

Parameter name	Title	Unit	Min	Max	Step	Default
Integer parameters of the dead line detection function						
DLD_ULev_IPar_	Min Operate Voltage	%	10	100	1	60
DLD_ILev_IPar_	Min Operate Current	%	2	100	1	10
Starting voltage and current parameter for residual and negative sequence detection:						
VTS_Uo_IPar_	Start URes	%	5	50	1	30
VTS_Io_IPar_	Start IRes	%	10	50	1	10
VTS_Uneg_IPar_	Start UNeg	%	5	50	1	10
VTS_Ineg_IPar_	Start INeg	%	10	50	1	10

Table 1-11 The integer parameters of the voltage transformer supervision function

Enumerated parameter

Parameter name	Title	Selection range	Default
Parameter for type selection			
VTS_Oper_EPar_	Operation	Off, Zero sequence, Neg. sequence, Special	Zero sequence

Table 1-12 The enumerated parameter of the voltage transformer supervision function

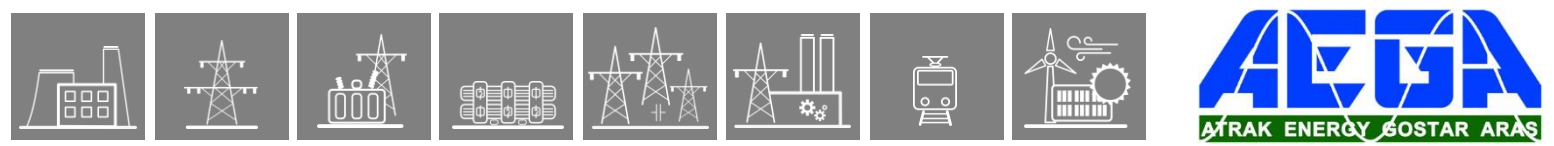

2.2.8.9.3. The binary input status signals

Binary status signals

The voltage transformer supervision function has a binary input signal, which serves the purpose of disabling the function. **The conditions of disabling are defined by the user, applying the graphic equation editor.**

Binary status signal	Explanation
VTS_BlK_GrO_	Output status of a graphic equation defined by the user to disable the voltage transformer supervision function.

Table 1-13 The binary input signal of the voltage transformer supervision function

2.2.8.9.4. Binary output status signals

The **binary output status signals** of the voltage transformer supervision function are listed in Table 1-14.

Binary output signals	Signal title	Explanation
DLD function		
DLD_StUL1_Grl_	Start UL1	The voltage of phase L1 is above the preset parameter value, signal of the DLD function
DLD_StUL2_Grl_	Start UL2	The voltage of phase L2 is above the preset parameter value, signal of the DLD function
DLD_StUL3_Grl_	Start UL3	The voltage of phase L3 is above the preset parameter value, signal of the DLD function
DLD_StIL1_Grl_	Start IL1	The current of phase L1 is above the preset parameter value, signal of the DLD function
DLD_StIL2_Grl_	Start IL2	The current of phase L2 is above the preset parameter value, signal of the DLD function
DLD_StIL3_Grl_	Start IL3	The current of phase L3 is above the preset parameter value, signal of the DLD function
DLD_DeadLine_Grl_	DeadLine condition	The requirements of "DeadLine condition" are fulfilled, signal of the DLD function
DLD_LineOK_Grl_	LineOK condition	The requirements of "LineOK condition" are fulfilled, signal of the DLD function
VTS function		
VTS_Fail_Grl	VT Failure	Failure status signal of the VTS function

Table 1-14 The binary output signals of the voltage transformer supervision function

2.2.8.9.5. The function block

The function block of the dead line detection and voltage transformer supervision function is shown in Figure 1-7. This block shows all binary input and output status signals that are applicable in the graphic equation editor.

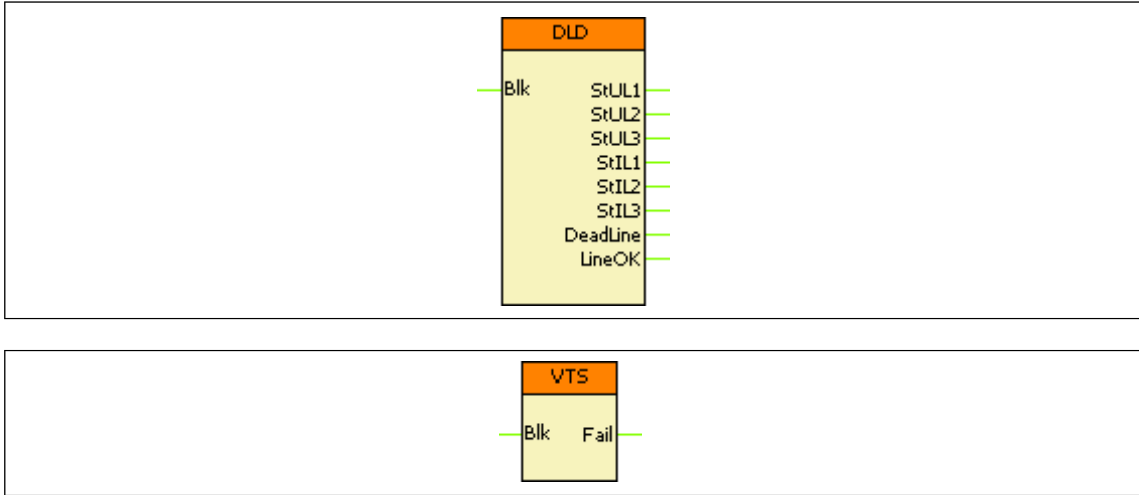

Figure 1-7 The function block of the dead line detection and voltage transformer supervision function

2.2.9. Current unbalance function

2.2.9.1. Application

The current unbalance protection function can be applied to detect unexpected asymmetry in current measurement.

2.2.9.1.1. Mode of operation

The applied method selects maximum and minimum phase currents (RMS values of the fundamental Fourier components). If the difference between them is above the setting limit, the function generates a start signal. It is a necessary precondition of start signal generation that the maximum of the currents be above 10 % of the rated current and below 150% of the rated current.

The function can be disabled by parameter setting, and by an input signal programmed by the user with the graphic programming tool.

The trip command is generated after the defined time delay if trip command is enabled by parameter setting.

2.2.9.1.2. Operation principles

Figure 1-1 shows the structure of the current unbalance protection algorithm.

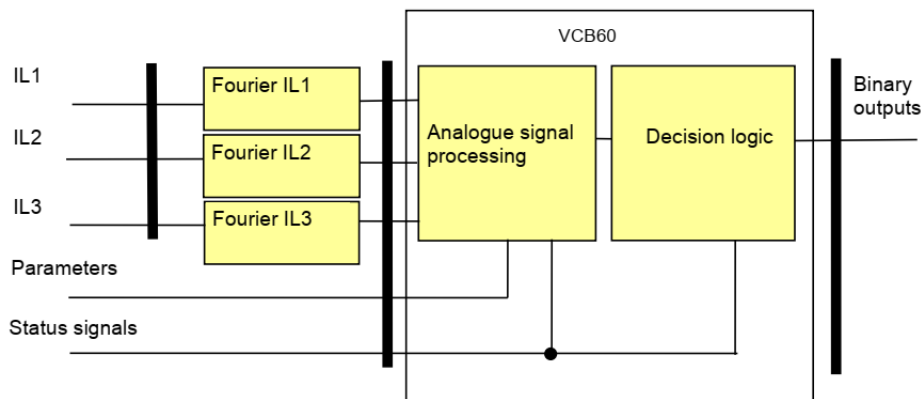

Figure 1-1 Structure of the current unbalance protection algorithm

The **inputs** of the preparatory phase are

- the three phase currents,

The **outputs** of the preparatory phase are

- the RMS values of the fundamental Fourier component of three phase currents.

The **inputs** of the current unbalance function are

- the RMS values of the fundamental Fourier component of three phase currents,
- parameters,
- status signals.

The **outputs** are

- the binary output status signals.

The **software modules** of the current unbalance function:

Fourier calculations

These modules calculate the RMS values of the basic Fourier current components of the phase currents individually (not part of the VCB60 function).

Analogue signal processing

This module processes the RMS values of the Fourier components of the phase currents to prepare the signals for the decision.

Decision logic

The decision logic module combines the status signals to generate the starting signal and the trip command of the function.

The following description explains the details of the individual components.

2.2.9.1.3. The Fourier calculation (Fourier)

These modules calculate the RMS values of the fundamental Fourier components of the phase currents individually. They are not part of the VCB60 function; they belong to the preparatory phase.

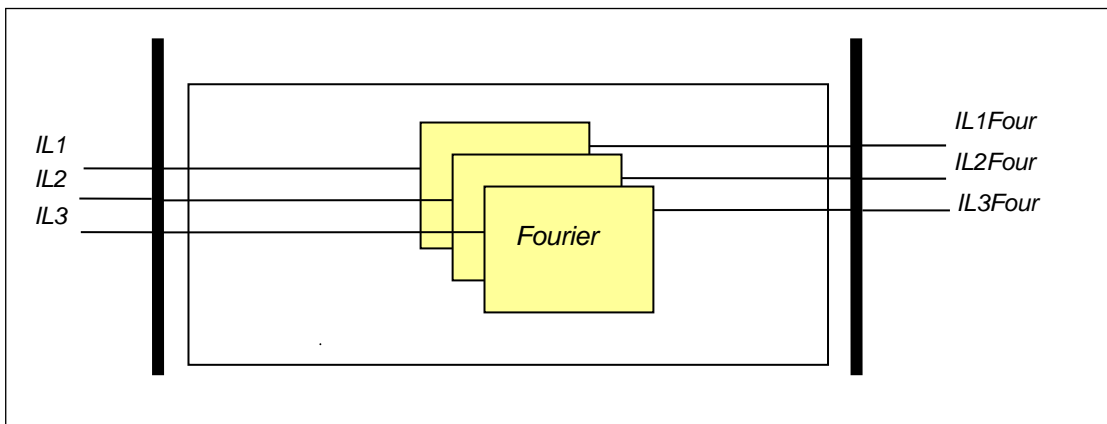

Figure 1-2 Principal scheme of the Fourier calculation

The **inputs** are the sampled values of the three phase currents (IL1, IL2, IL3)

The **outputs** are the RMS values of the fundamental Fourier components of the phase currents (IL1Four, IL2Four, IL3Four).

2.2.9.1.5. The decision logic (Decision logic)

The decision logic module combines the status signals, binary and enumerated parameters to generate the trip command of the function.

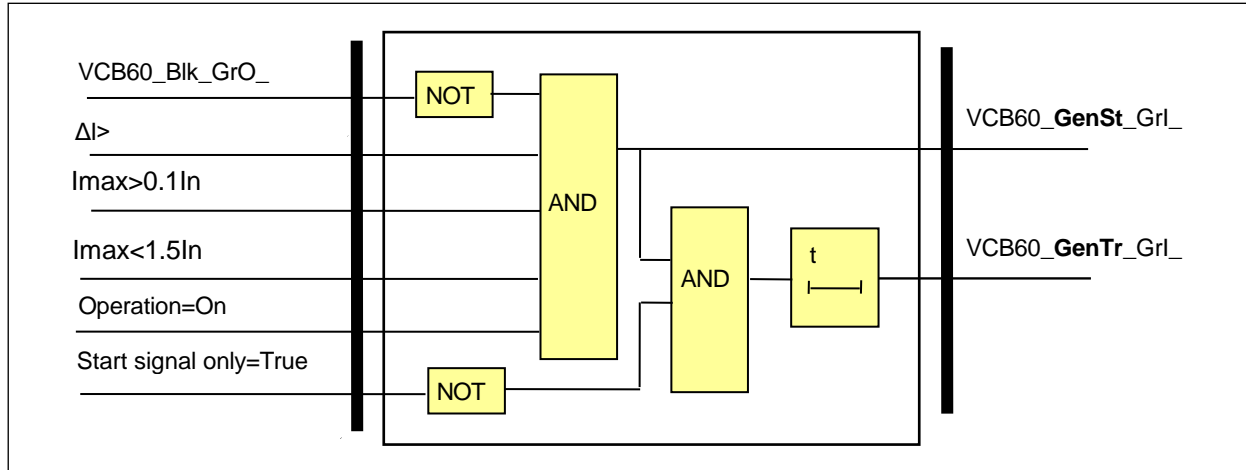

Figure 1-4 The logic scheme of the current unbalance function

The **inputs** are internal binary signals:

- $\Delta I >$ the difference between the maximum and minimum of the RMS values of the fundamental Fourier components of the phase currents as a percentage of the maximum of these values is above the limit defined by parameter setting "Start Current Diff";
- $I_{max} > 0.1 I_n$ the maximum of the RMS values of the fundamental Fourier components of the phase currents is sufficient for evaluation;
- $I_{max} < 1.5 I_n$ the maximum of the RMS values of the fundamental Fourier components of the phase currents is not considered as a fault current.

2.2.9.2. Current unbalance protection function overview

The graphic appearance of the function block of the current unbalance protection function is shown below. The block shows all binary input and output status signals which are applicable in the graphic equation editor.

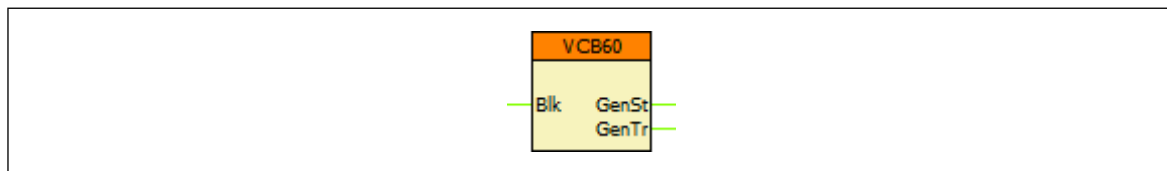

Figure 2-1 Graphic appearance of the function block of the current unbalance protection function

2.2.9.2.1. Settings

2.2.9.2.1.1. Parameters

The available parameters are listed below in order of their appearance in the *parameters* menu. If the setting range of a parameter should be extended, contact Protecta Support.

Table 2-1 Parameters of the current unbalance protection function

TITLE	DIM	RANGE	STEP	DEFAULT	EXPLANATION
Operation	-	Off, On	-	Off	Enabling the function
Start Signal Only	-	FALSE, TRUE	-	FALSE	When checked, the function provides start signal only, and no trip signal.
Start Current	%	10 – 90	1	50	Phase difference current setting
Time Delay	msec	100 – 60000	1	1000	Time delay (including the algorithm time, see Chapter 2.4 for more explanation)

2.2.9.2.2. Function I/O

This section describes briefly the analogue and digital inputs and outputs of the function block.

2.2.9.2.2.1. Analogue inputs

The function uses the sampled values of a current input. This is defined in the configuration.

2.2.9.2.2.2. Binary input signals (graphed output statuses)

The conditions of the binary inputs are defined by the user, applying the graphic equation editor (*Logic Editor*). Parts written in **bold** are seen on the left side function block in the Logic editor.

Table 2-2 The binary input signal of the current unbalance protection function

BINARY OUTPUT SIGNAL	EXPLANATION
VCB60_ Blk _GrO_	Blocking input of the function

2.2.9.2.2.3. Binary output signals (graphed input statuses)

These signals can be used in EuroCAP to assign to LED, user LCD object etc. Parts written in **bold** are seen on the right side of the function block in the *Logic Editor*.

Table 2-3 The binary output signals of the current unbalance protection function

BINARY OUTPUT SIGNAL	SIGNAL TITLE	EXPLANATION
VCB60_ GenSt _Grl_	General Start	General start signal of the function
VCB60_ GenTr _Grl_	General Trip	General trip command of the function

2.2.9.2.2.4. Online data

Visible values on the *online data* page.

Table 2-4 Online displayed data of the current unbalance protection function

SIGNAL TITLE	DIMENSION	EXPLANATION
General Start	-	General start signal of the function
General Trip	-	General trip command of the function

2.2.9.2.2.5. Events

The following events are generated in the event list, as well as sent to the SCADA according to the configuration.

Table 2-5 Generated events of the current unbalance protection function

EVENT	VALUE	EXPLANATION
General Start	off, on	General start of the function
General Trip	off, on	General trip command of the function

2.2.9.2.3. Technical data

Table 2-6 Technical data of the current unbalance protection function

FUNCTION	VALUE	ACCURACY
Pick-up starting accuracy at In		< 2 %
Reset ratio	0,95	
Operate time	70 ms	

2.2.9.2.4. Notes for testing

Normally in the EuroProt+ devices the trip contacts are assigned to the Trip Logic function block, and not to the protection function blocks. Because of this, the testing personnel must make sure that the Trip Logic is switched on ('Operation' parameter is set to other than 'Off') before starting the tests, otherwise there will be no physical trip on the relay.

Note that the time delay parameter incorporates the algorithm time as well, so the time delay *does not mean the time difference between the appearance of the start and trip signals* of the function. In other words: it is not the delay between the detection of the fault and the trip that follows it. This should be taken into consideration when checking the disturbance records.

Instead the time delay parameter defines the elapsed time from the appearance of the faulty state to the trip. Because of this, while testing, the delay measurement should start *from the moment of the fault injection* until the trip signal.

2.3. Measuring functions

The measured values can be checked on the touch-screen of the device in the “On-line functions” page, or using an Internet browser of a connected computer. The displayed values are secondary voltages and currents, except the block “Line measurement”. This specific block displays the measured values in primary units, using VT and CT primary value settings.

Analog value	Explanation
VT4 module	
Voltage Ch – U1	RMS value of the Fourier fundamental harmonic voltage component in phase L1
Angle Ch – U1	Phase angle of the Fourier fundamental harmonic voltage component in phase L1*
Voltage Ch – U2	RMS value of the Fourier fundamental harmonic voltage component in phase L2
Angle Ch – U2	Phase angle of the Fourier fundamental harmonic voltage component in phase L2*
Voltage Ch – U3	RMS value of the Fourier fundamental harmonic voltage component in phase L3
Angle Ch – U3	Phase angle of the Fourier fundamental harmonic voltage component in phase L3*
Voltage Ch – U4	RMS value of the Fourier fundamental harmonic voltage component in Channel U4
Angle Ch – U4	Phase angle of the Fourier fundamental harmonic voltage component in Channel U4*
CT4 module	
Current Ch - I1	RMS value of the Fourier fundamental harmonic current component in phase L1
Angle Ch - I1	Phase angle of the Fourier fundamental harmonic current component in phase L1*
Current Ch - I2	RMS value of the Fourier fundamental harmonic current component in phase L2
Angle Ch - I2	Phase angle of the Fourier fundamental harmonic current component in phase L2*
Current Ch - I3	RMS value of the Fourier fundamental harmonic current component in phase L3
Angle Ch - I3	Phase angle of the Fourier fundamental harmonic current component in phase L3*
Current Ch - I4	RMS value of the Fourier fundamental harmonic current component in Channel I4
Angle Ch - I4	Phase angle of the Fourier fundamental harmonic current component in Channel I4*
<i>Distance protection function (DIS21_HV)</i>	
Fault location	Measured distance to fault
Fault react.	Measured reactance in the fault loop
L1N loop R	Resistive component value of impedance in L1-N loop
L1N loop X	Reactive component value of impedance in L1-N loop
L2N loop R	Resistive component value of impedance in L2-N loop
L2N loop X	Reactive component value of impedance in L2-N loop
L3N loop R	Resistive component value of impedance in L3-N loop
L3N loop X	Reactive component value of impedance in L3-N loop
L12 loop R	Resistive component value of impedance in L12 loop
L12 loop X	Reactive component value of impedance in L12 loop
L23 loop R	Resistive component value of impedance in L23 loop
L23 loop X	Reactive component value of impedance in L23 loop
L31 loop R	Resistive component value of impedance in L31 loop
L31 loop X	Reactive component value of impedance in L31 loop

<i>Synchrocheck function (SYN25)</i>	
Voltage Diff	Voltage different value
Frequency Diff	Frequency different value
Angle Diff	Angle different value
<i>Line measurement (MXU_L) (here the displayed information means primary value)</i>	
Active Power – P	Three-phase active power
Reactive Power – Q	Three-phase reactive power
Apparent Power – S	Three-phase power based on true RMS voltage and current measurement
Current L1	True RMS value of the current in phase L1
Current L2	True RMS value of the current in phase L2
Current L3	True RMS value of the current in phase L3
Voltage L1	True RMS value of the voltage in phase L1
Voltage L2	True RMS value of the voltage in phase L2
Voltage L3	True RMS value of the voltage in phase L3
Voltage L12	True RMS value of the voltage between phases L1 L2
Voltage L23	True RMS value of the voltage between phases L2 L3
Voltage L31	True RMS value of the voltage between phases L3 L1
Frequency	Frequency
<i>Metering (MTR)</i>	
Forward MWh	Forward MWh
Backward MWh	Backward MWh
Forward MVAh	Forward MVAh
Backward MVAh	Backward MVAh
<i>Line thermal protection (TTR49L)</i>	
Calc. Temperature	Calculated line temperature

* The reference angle is the phase angle of “Voltage Ch - U1”

Table 3-146 Measured analog values

2.3.1. Current input function

2.3.1.1. Application of the current input function

The application of the current inputs depends on the correct connection of the hardware terminals and also on the correct parameter setting for the CT4 function block. This guide describes examples, based on which any other combinations can be realized.

In the applications of the current transformer hardware module, the first three current inputs (terminals 1-2, 3-4, 5-6) receive the three phase currents (IL1, IL2, IL3), the fourth input (terminals 7-8) is reserved for zero sequence current, for the zero sequence current of the parallel line or for any additional currents. Accordingly, the first three inputs have common parameters while the fourth current input needs individual setting.

The CT4 function block is an independent module in the sense that:

- It has independent parameters to be set, associated to the current inputs,
- It delivers the sampled current values for protection, measurement function blocks and for disturbance recording and for on-line displaying,
- It provides parameters for the subsequent functions blocks for scaling the measured currents.
- It performs the basic calculations
 - Fourier basic harmonic magnitude and angle,
 - True RMS value.

2.3.1.1.1. Parameter setting

2.3.1.1.1.1. Summary of the parameters

The parameters of the current input function are explained in the following tables.

Enumerated parameters

Parameter name	Title	Selection range	Default
Rated secondary current of the first three input channels. 1A or 5A is selected by parameter setting, no hardware modification is needed.			
CT4_Ch13Nom_EPar_	Rated Secondary I1-3	1A,5A	1A
Rated secondary current of the fourth input channel. 1A or 5A (0.2A, 1A) is selected by parameter setting, no hardware modification is needed.			
CT4_Ch4Nom_EPar_	Rated Secondary I4	1A,5A (0.2A, 1A)	1A
Definition of the positive direction of the first three currents, given by location of the secondary star connection point			
CT4_Ch13Dir_EPar_	Starpoint I1-3	Line,Bus	Line
Definition of the positive direction of the fourth current, given as normal or inverted			
CT4_Ch4Dir_EPar_	Direction I4	Normal,Inverted	Normal

Table 1-1 The enumerated parameters of the current input function

Floating point parameters

Parameter name	Title	Dim.	Min	Max	Default
Rated primary current of channel1-3					
CT4_PrI13_FPar_	Rated Primary I1-3	A	100	4000	1000
Rated primary current of channel4					
CT4_PrI4_FPar_	Rated Primary I4	A	100	4000	1000

Table 1-2 The floating point parameters of the current input function

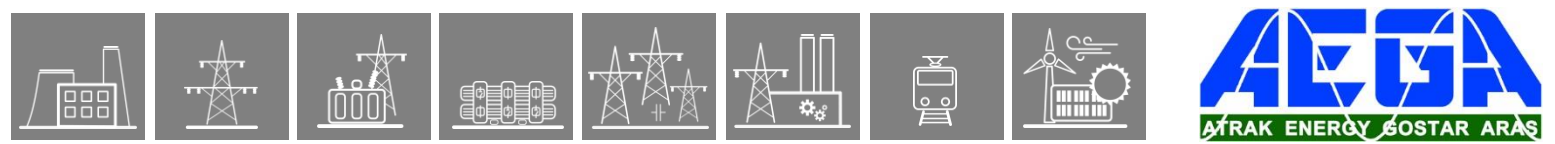

NOTE: The rated primary current of the channels is not needed for the current input function block itself. These values are passed on to the subsequent function blocks.

2.3.1.1.1.2. Setting the rated secondary current

The scaling of the currents (even hardware scaling) depends on parameter setting.

Rated Secondary I1-3 and Rated Secondary I4

Select the rated secondary current according to the nominal data of the main current transformer. The options to choose from are 1A or 5A (in special applications, 0.2A or 1A). This parameter influences the internal number format and, naturally, accuracy. (A small current is processed with finer resolution if 1A is selected.) The first parameter is common for the first three channels and the second one is applied for the fourth channel.

NOTE: when selecting from the available choice, no hardware modification is needed.

2.3.1.1.1.3. Setting the positive direction of the currents

The positive direction of the currents influences the correct operation of directionality (e.g. distance protection, directional overcurrent protection, power calculation, etc.) If needed, the currents can be inverted by setting parameters. This is equivalent to interchanging the two wires, connecting the currents to the inputs.

Starpoint I1-3 and Direction I4.

Starpoint I1-3 applies to each of the channels IL1, IL2 and IL3. The example of Figure 1-1 below shows the connection and the correct parameter setting for Starpoint I1-3=Line. The current L1 is connected to terminal No1 of the CT input, the current L2 to No3, and the current L3 to No5. The common point of the CT inputs is the connected No2-No4-No6. This point leads the residual current to the input No7. The connection point No8 is connected with the fourth wire to the star-point of the CTs. This application of the fourth channel is the "Normal" direction.

If the currents are connected not this way then change the parameter values accordingly.

2.3.1.1.1.4. Setting the rated primary current

These parameters are needed only to display the currents (and powers) in primary scale. The protection function apply secondary values, these parameters are not needed for protection functions.

Rated Primary I1-3 and Rated Primary I-4

Select the rated primary currents according to the nominal data of the main current transformers. The first parameter (Rated Primary I1-3) is common for the first three channels and the second (Rated Primary I-4) is for the fourth channel.

2.3.1.1.2. Application of the on-line measurements in commissioning

The **measured values** of the current input function block are listed and explained in the Table below.

Measured value	Dim.	Explanation
Current Ch - I1	A(secondary)	Fourier basic component of the current in channel IL1
Angle Ch - I1	degree	Vector position of the current in channel IL1
Current Ch - I2	A(secondary)	Fourier basic component of the current in channel IL2
Angle Ch - I2	degree	Vector position of the current in channel IL2
Current Ch - I3	A(secondary)	Fourier basic component of the current in channel IL3
Angle Ch - I3	degree	Vector position of the current in channel IL3
Current Ch - I4	A(secondary)	Fourier basic component of the current in channel I4
Angle Ch - I4	degree	Vector position of the current in channel I4

Table 1-3 The measured analogue values of the current input function

NOTE1: The scaling of the Fourier basic component is such that if pure sinusoid 1A RMS of the rated frequency is injected, the displayed value is 1A.

NOTE2: The reference of the vector position depends on the device configuration. If a voltage input module is included, then the reference vector (vector with angle 0 degree) is the vector calculated for the first voltage input channel of the first applied voltage input module. If no voltage input module is configured, then the reference vector (vector with angle 0 degree) is the vector calculated for the first current input channel of the first applied current input module. (The first input module is the one, located closer to the CPU module.)

2.3.1.1.3. Examples

When the vector position of the currents are relevant (e.g. distance protection, directional overcurrent protection, power measurement, etc.) then mind the correct connection of the instrument transformers and the related parameter setting. If the wires of the secondary cables are interchanged then change also the related parameter values.

2.3.1.1.3.1. Residual current measurement

Figure 1-1 shows a connection example with 3I₀ measurement. The star-point of the CT-s is towards the line, L1 is connected to terminal No1 of the CT input, L2 to No3, L3 to No5.

The common point of the CT inputs is the connected No2-No4-No6. This point leads the residual current to the input No7. The connection point No8 is connected with the fourth wire to the star-point of the CTs.

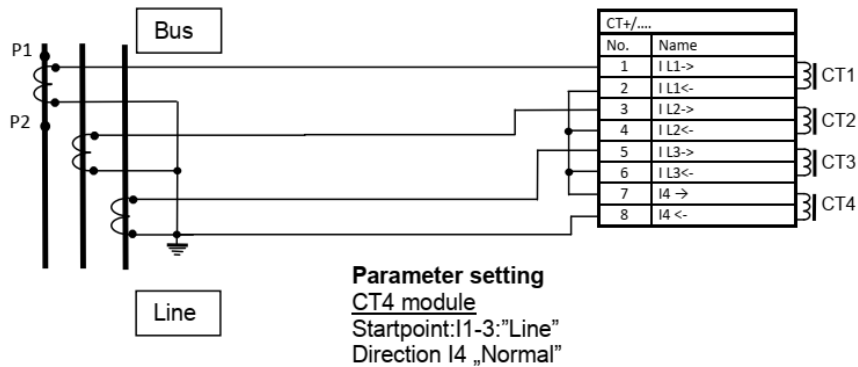

Figure 1-1 Example: CT connection with 3I₀ measurement

The related proposed parameter setting is the screen-shot of Figure 1-2. Parameter “Starpoint I1-3” is set to “Line”, indicating that the star-point is toward the protected object (line). The parameter “Direction I4” is set to “Normal”, indicating that the residual current flows in to terminal No7 and the star point of the primary current transformer is toward the protected object (line).

	Device value (Default_set_1)	New value		
Rated Secondary I1-3	1A	1A		
Rated Secondary I4	1A	1A		
Starpoint I1-3	Line	Line		
Direction I4	Normal	Normal		
Rated Primary I1-3	1000	1000	A	(100 - 4000 / 1)
Rated Primary I4	1000	1000	A	(100 - 4000 / 1)

Figure 1-2 Example: Parameter setting, according to Figure 1-1

In case of normal operation of the network, the correct connection of the CT-s and the related parameter setting can be checked using the “On-line” measurements. Disconnect one phase of the protected line, e.g. L1. The expected result is shown in Figure 1-3. The current is missing in phase L1 (Current Ch-I1 = 0) and the measured 3I₀ value is the vector sum of the remaining I₂+I₃. (Value of “Current Ch - I4” with the related “Angle - I4”).

NOTE: If in this test, only the secondary current is disclosed using a short measuring cable, then the measured current in this phase is usually not zero, due to the current distribution between the low-impedance input and the impedance of the measuring cable. For correct result, additionally to the short-circuit, also the disconnection of this input is needed. In this example the reference vector is the vector of the first voltage channel (not shown in the screenshot).

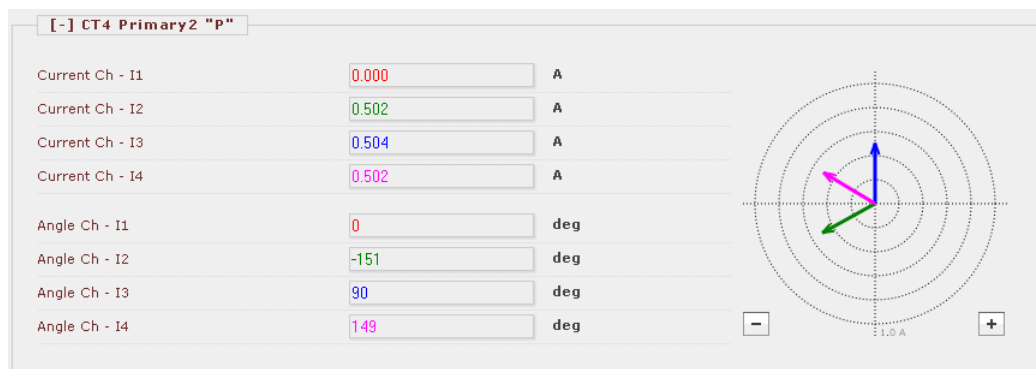

Figure 1-3 Example: Checking the current connection

2.3.1.1.3.2. Application of core-balanced CT

Figure 1-4 shows a connection example with 3I₀ measurement. The star-point of the CT-s is towards the line, L1 is connected to terminal No1 of the CT input, L2 to No3, L3 to No5. The common point of the CT inputs is the connected No2-No4-No6. The separately measured residual current is connected with the same polarity to terminals 7-8.

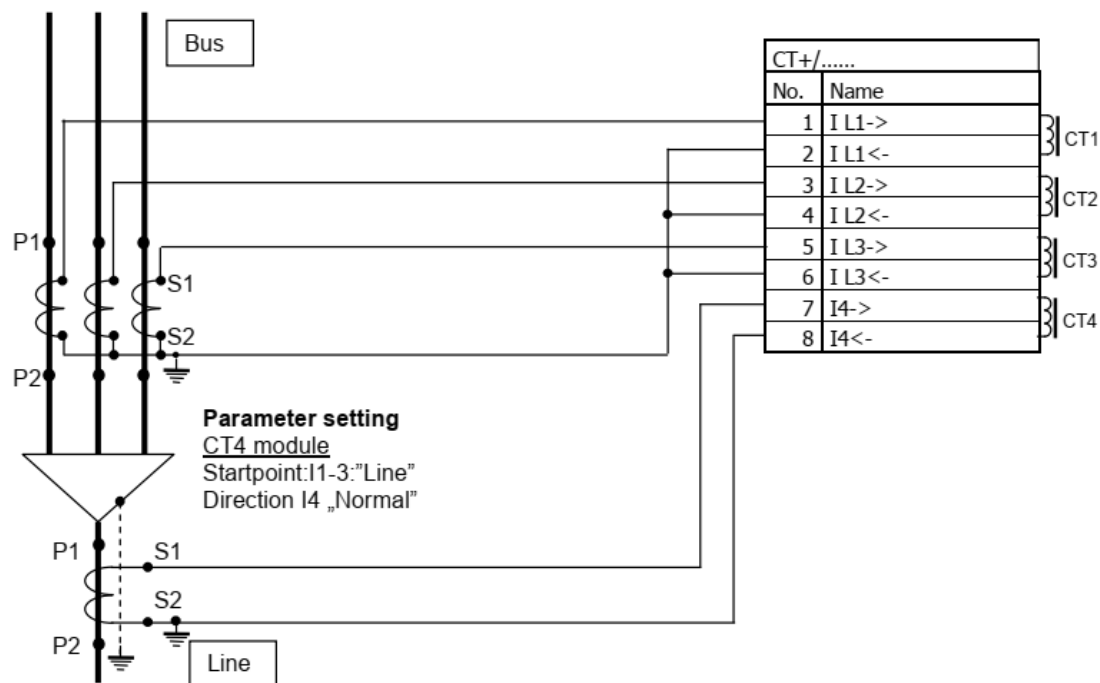

Figure 1-4 Example: CT connection with core-balance CT application

This figure also indicates the proposed parameter values for this connection. The checking is similar to that, shown in Figure 1-3.

2.3.2. AIC current input function

2.3.2.1. Application of the AIC current input function

If the factory configuration includes an AIC input hardware module, the AIC current input function block is automatically configured among the software function blocks. Separate current input function blocks are assigned to each AIC current input hardware module.

The AIC current input module accepts transducers current outputs. The AIC module has four channels, they can measure unipolar and bipolar current values in wide ranges. (See EuroProt+ hardware description document.) The transducer converts any physical quantity to DC current values.

The transmitters can be connected by wiring methods, shown in Figure 1–1, Figure 1–2 and Figure 1–3.

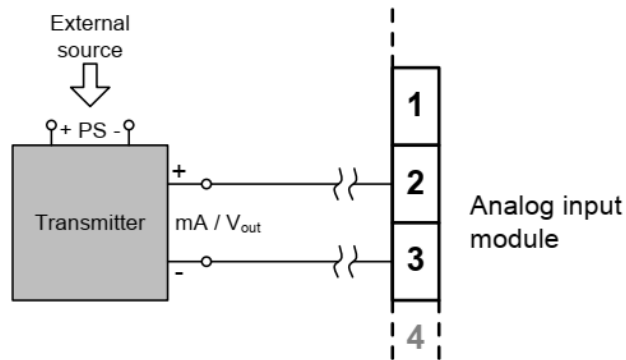

Figure 1–1 2-wire AIC wiring without 12 V excitation

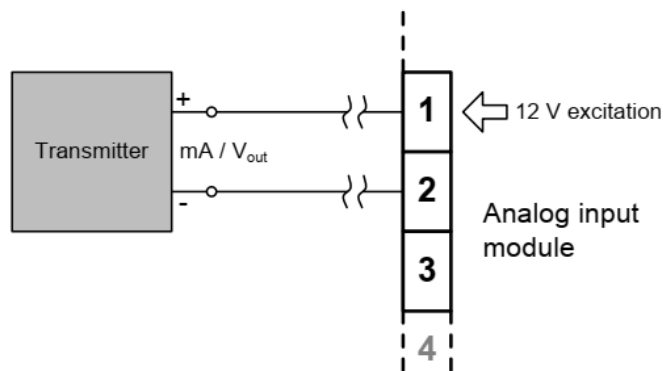

Figure 1–2 2-wire AIC wiring with 12 V excitation

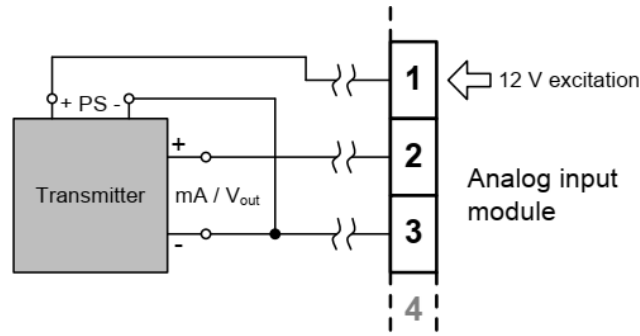

Figure 1–3 3-wire AIC wiring with 12 V excitation

The channels of the module are independent of each other. To each channel a dedicated measuring module is assigned. These measuring modules are described in a separate document: “**GGIOmA current measurement module function block description**”.

2.3.2.2. Technical summary

2.3.2.2.1. Technical data

The technical data of the AIC analog current input module are related to the hardware module. This is described in the document “**EuroProt+ Hardware description**, Chapter 11: analog input module”.

2.3.2.2.2. Summary of the parameters

The parameters of the AIC analog current input function are explained in the following table.

Enumerated parameters

Parameter name	Title	Selection range	Default
Polarity of Channel 1			
AIC_Ch1Dir_EPar_1	Direction - Ch1	Normal,Inverted*	Normal
Polarity of Channel 2			
AIC_Ch2Dir_EPar_1	Direction – Ch2	Normal,Inverted*	Normal
Polarity of Channel 3			
AIC_Ch3Dir_EPar_1	Direction – Ch3	Normal,Inverted*	Normal
Polarity of Channel 4			
AIC_Ch4Dir_EPar_1	Direction – Ch4	Normal,Inverted*	Normal

*Figures 1-1, 1-2 and 1-3 show “Normal” connection polarity

Table 1-1 The enumerated parameters of the current input function

NOTE: The function block has no input and output binary signals, the graphic logic editor does not show this function block.

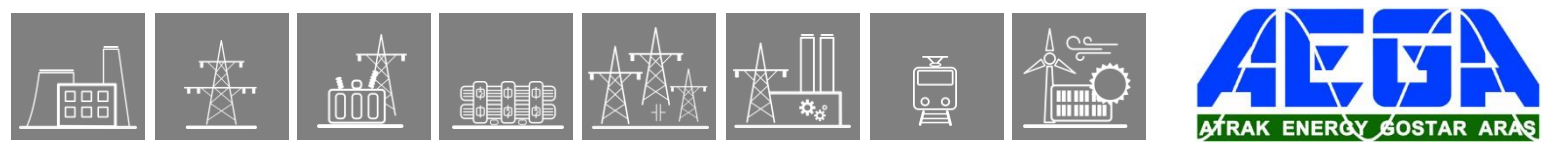

2.3.3. Voltage input function

2.3.3.1. Application of the voltage input function

The application of the voltage inputs depends on the correct connection of the hardware terminals and also on the correct parameter setting for the VT4 function block. This guide describes examples, based on which any other combinations can be realized.

In the applications of the voltage transformer hardware module, the first three voltage inputs receive the three phase voltages (UL1, UL2, UL3), the fourth input is reserved for zero sequence voltage, for the busbar voltage if synchronized switching is applied or for any additional voltages. Accordingly, the first three inputs have common parameters while the fourth voltage input needs individual setting.

The VT4 function block is an independent module in the sense that:

- It has independent parameters to be set, associated to the voltage inputs,
- It delivers the sampled voltage values for protection, measurement function blocks and for disturbance recording,
- It provides parameters for the subsequent functions blocks for scaling the measured voltages.
- It performs the basic calculations
 - Fourier basic harmonic magnitude and angle,
 - True RMS value.

2.3.3.1.1. Parameter setting

2.3.3.1.1.1. Summary of the parameters

The parameters of the voltage input function are explained in the following tables.

Enumerated parameters

Parameter name	Title	Selection range	Default
Rated secondary voltage of the input channels. 100 V or 200V is selected by parameter setting, no hardware modification is needed.			
VT4_Type_EPar_	Range	Type 100,Type 200	Type 100
Connection of the first three voltage inputs (main VT secondary)			
VT4_Ch13Nom_EPar_	Connection U1-3	Ph-N, Ph-Ph, Ph-N-Isolated	Ph-N
Selection of the fourth channel input: phase-to-neutral or phase-to-phase voltage			
VT4_Ch4Nom_EPar_	Connection U4	Ph-N,Ph-Ph	Ph-Ph
Definition of the positive direction of the first three input channels, given as normal or inverted			
VT4_Ch13Dir_EPar_	Direction U1-3	Normal,Inverted	Normal
Definition of the positive direction of the fourth voltage, given as normal or inverted			
VT4_Ch4Dir_EPar_	Direction U4	Normal,Inverted	Normal

Table 1-1 The enumerated parameters of the voltage input function

Integer parameter

Parameter name	Title	Unit	Min	Max	Step	Default
Voltage correction						
VT4_CorrFact_IPar_	VT correction	%	100	115	1	100

Table 1-2 The integer parameter of the voltage input function

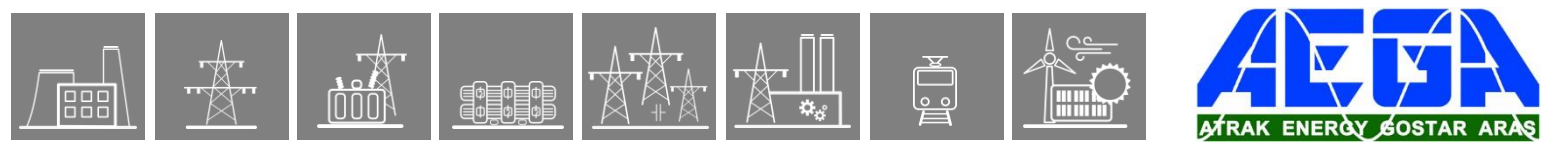

Floating point parameters

Parameter name	Title	Dim.	Min	Max	Default
Rated primary voltage of channel 1, 2, 3					
VT4_PriU13_FPar	Rated Primary U1-3	kV	1	1000	100
Rated primary voltage of channel 4					
VT4_PriU4_FPar	Rated Primary U4	kV	1	1000	100

Table 1-3 The floating point parameters of the voltage input function

NOTE: The rated primary voltage of the channels is not needed for the voltage input function block itself. These values are passed on to the subsequent function blocks.

2.3.3.1.1.2. Setting the rated secondary voltage

The scaling of the voltage depends on parameter setting.

Range

There are basically two standard voltage transformer types: one with secondary rated voltage 100 V, the other with 200 V. Select the parameter value respectively: Type 100, Type 200. No hardware modification is needed. This parameter influences the internal number format and, naturally, accuracy. (A small voltage is processed with finer resolution if 100V is selected.)

VT correction

In some cases the rated secondary of the voltage transformers is not 100V but e.g. 110 V. This parameter is to correct this difference, if the rated secondary voltage of the main voltage transformer does not match the rated input of the device. As an example: if the rated secondary voltage of the main voltage transformer is 110V, then select Type 100 for the parameter "Range" and the required value to set here is 110%.

2.3.3.1.1.3. Setting the connection and the positive direction of the voltages

The connection and direction parameters of the first three VT secondary windings must be set to reflect actual physical connection of the main VTs.

Connection U1-3.

The selection can be: "Ph-N", "Ph-Ph" or "Ph-N-Isolated".

The *Ph-N* option is applied in solidly grounded networks, where the measured phase voltage is never above $1.5 \cdot U_n$. In this case the primary rated voltage of the VT must be the value of the rated PHASE-TO-NEUTRAL voltage.

The *Ph-N-Isolated* option is applied in compensated or isolated networks, where the measured phase voltage can be above $1.5 \cdot U_n$ even in normal operation. In this case the primary rated voltage of the VT must be the value of the rated PHASE-TO-PHASE voltage.

The *Ph-Ph* option is to be selected if phase-to-phase voltage is connected to the VT input of the device. Here, the primary rated voltage of the VT must be the value of the rated PHASE- TO-PHASE voltage. This option must not be selected if the distance protection function or directional overcurrent protection function is supplied from the VT input.

Connection U4



The fourth input is reserved for zero sequence voltage or for a voltage from the other side of the circuit breaker for synchronized switching. Accordingly, the connected voltage must be identified with parameter setting Connection U4. Here, phase-to-neutral or phase-to-phase voltage can be selected: “Ph-N”, “Ph-Ph”

Direction U1-3

If needed, the phase voltages can be inverted by setting the parameter Direction U1-3. This selection applies to each of the channels UL1, UL2 and UL3. The primary/secondary connection of the VT windings is generally star/star connected and the phase voltages signed with • are connected to the VT4 terminals 1-3-5. In this case the parameter setting is „Normal”. Select “Inverted” to the parameter Direction U1-3 in case of inverted connection of phase voltages.” (See also Figure 1-1 in setting example.)

Direction U4

This parameter applies to the channel UL4. If the voltage signed with • is connected to the VT4 terminal 7 the parameter setting is „Normal”. Select “Inverted” to the parameter Direction U4 in case of inverted connection of the voltage. This inversion may be needed in protection functions such as distance protection or for any functions with directional decision, or for checking the voltage vector positions.

Figure 1-1 shows an example with harmonized connection and parameter setting.

If the voltages are connected not this way then change the parameter values accordingly.

2.3.3.1.1.4. Setting the rated primary voltage

These parameters are needed only to display the voltages (and powers) in primary scale. The protection functions apply secondary values, these parameters are not needed for protection functions.

Rated Primary U1-3 and Rated Primary U-4

Select the rated primary voltages according to the nominal data of the main voltage transformers. The two parameters are: common for the first three channels and one for the fourth channel respectively.

2.3.3.1.2. Application of the on-line measurements in commissioning

The performed basic calculation results the Fourier basic harmonic magnitude and angle value of the voltages. These results are processed by subsequent protection function blocks and they are available for on-line displaying as well.

2.3.3.1.2.1. Summary of the on-line measurements

The **measured values** of the voltage input function block.

Measured value	Dim.	Explanation
Voltage Ch - U1	V(secondary)	Fourier basic component of the voltage in channel UL1
Angle Ch - U1	degree	Vector position of the voltage in channel UL1
Voltage Ch - U2	V(secondary)	Fourier basic component of the voltage in channel UL2
Angle Ch - U2	degree	Vector position of the voltage in channel UL2
Voltage Ch - U3	V(secondary)	Fourier basic component of the voltage in channel UL3
Angle Ch - U3	degree	Vector position of the voltage in channel UL3
Voltage Ch - U4	V(secondary)	Fourier basic component of the voltage in channel U4
Angle Ch - U4	degree	Vector position of the voltage in channel U4

Table 1-4 The measured analogue values of the voltage input function

NOTE1: The scaling of the Fourier basic component is such that if pure sinusoid 57V RMS of the rated frequency is injected, the displayed value is 57V.

NOTE2: The reference vector (vector with angle 0 degree) is the vector calculated for the first voltage input channel of the first applied voltage input module. (The first voltage input module is the one, configured closer to the CPU module.)

2.3.3.1.3. Examples

When the vector position of the voltages are relevant (e.g. distance protection, directional overcurrent protection, power measurement, synchrocheck, etc.) then mind the correct connection of the instrument transformers and the related parameter setting. If the wires of the secondary cables are interchanged then change also the related parameter values.

2.3.3.1.3.1. Phase voltage and residual voltage measurement

Figure 1-1 shows the phase voltage measurement and also the residual voltage measurement e.g. for residual directional overcurrent protection function. In this example the residual voltage is measured in open delta of the VT secondary coils. The network is supposed to be compensated. This figure also indicates the proposed parameter values.

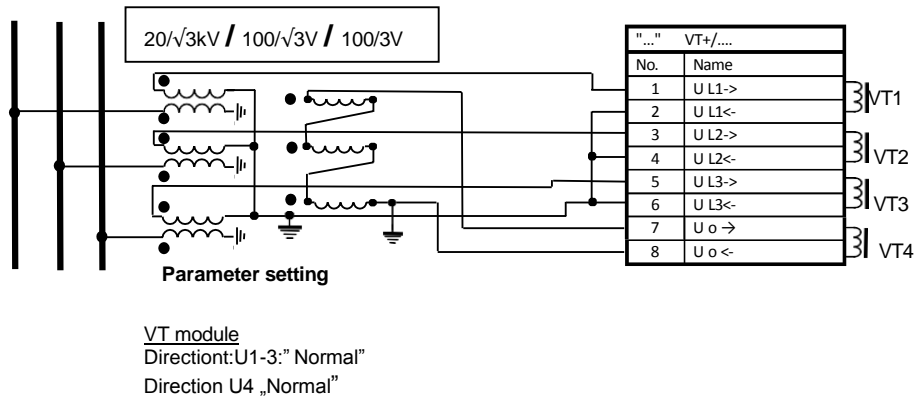

Figure 1-1 Example: Phase voltage and residual voltage measurement

Range	Type 100	The type indicates the rated secondary voltage of the VT. This can be 100 V (in this example) or 200V
Connection U1-3	Ph-N-Isolated	This indicates that the VT primary is connected between the conductor and the ground (in this example in compensated network). This could be Ph-N or Ph-Ph in other application. (NOTE: If the neutral of the system is not grounded, select Ph-N-Isolated)
Connection U4	Ph-Ph	In case of earth fault the open delta measures 100 V. This corresponds to the phase-to-phase value
Direction U1-3	Normal	Figure 1-1 shows the normal VT connection, i.e. the signed • phase wires are connected to the terminals 1-3-5. (Select "Inverted" in case of inverted connection.)
Direction U4	Normal	Figure 1-1 shows the normal VT connection, i.e. the signed • wire of the open delta of VT-s is connected to the terminal 7. (Select "Inverted" in case of inverted connection.)
VT correction	100	If the rated secondary value of the VT is e.g. 110 V then select this correction value to 110%.
Rated Primary U1-3	20	Setting, according to the VT rated voltage, applied at the primary side. This parameter is used for scaling the displayed values only.
Rated Primary U4	11.55	This parameter is used for scaling the displayed values only. In case of earth fault, the open delta measures 100 V. In primary value it is displayed as the phase voltage in the 20 kV network.

Table 1-5 Example parameters for the voltage input function

2.3.3.1.3.2. Syncrocheck using phase-to neutral voltage

Figure 1-2 shows the application of the fourth voltage input of the VT module for syncrocheck function. Here UL2 of the busbar voltage is used for this purpose.

NOTE: Among syncrocheck parameters set "Voltage select" parameter to "L2-N".

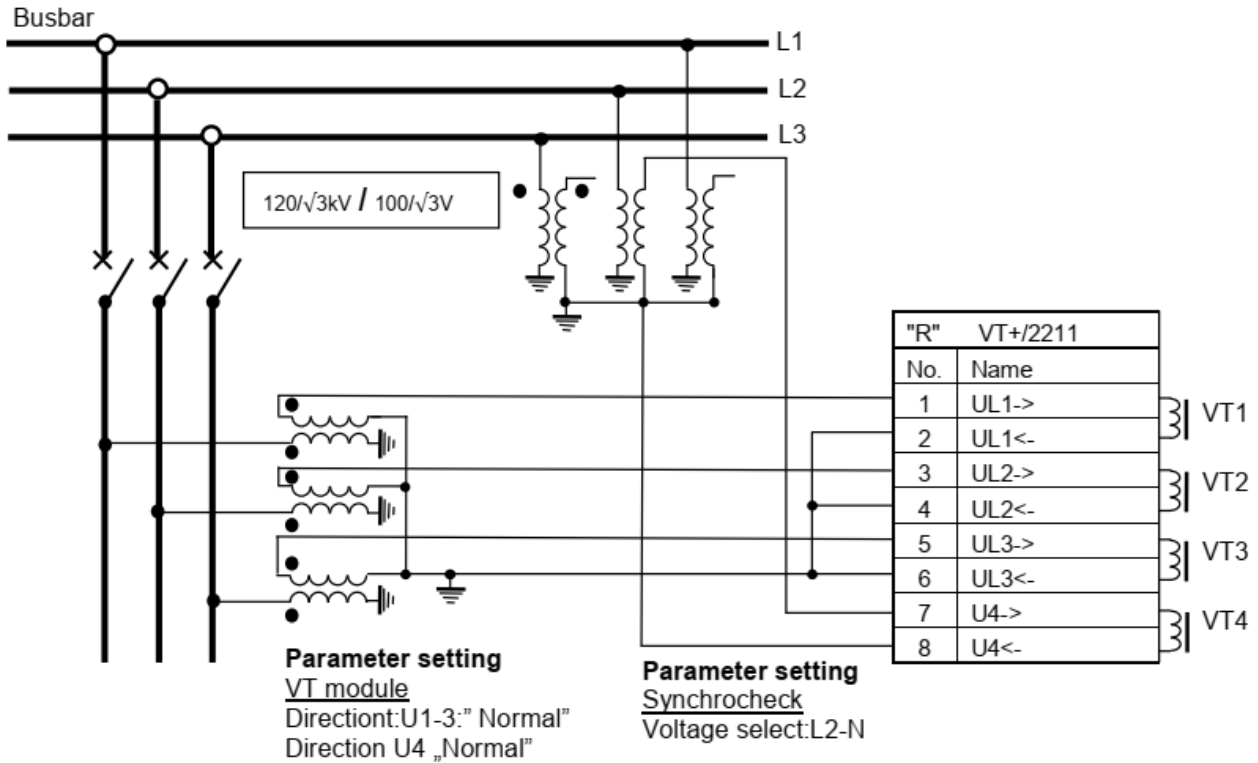

Figure 1-2 Example: Syncrocheck, using phase-to-neutral voltage

Figure 1-3 shows the screenshot indicating the proposed parameter values.

	Device value (Default_set_1)	New value		
Range	Type 100	Type 100		
Connection U1-3	Ph-N	Ph-N		
Connection U4	Ph-N	Ph-N		
Direction U1-3	Normal	Normal		
Direction U4	Normal	Normal		
VT correction	100	100	%	(100 - 115 / 1)
Rated Primary U1-3	69.28	69.28	kV	(1.00 - 1000.00 / 0.01)
Rated Primary U4	69.28	69.28	kV	(1.00 - 1000.00 / 0.01)

Figure 1-3 Example:Parameters for syncrocheck, using phase-to-neutral voltage

The "On-line window" of the VT4 input module shows the checking the correct voltage vector position. When the line is connected to the busbar, i.e. the CB is closed, in this example the U4 voltage is expected to have the same value and position as U2. See Figure 1-4.

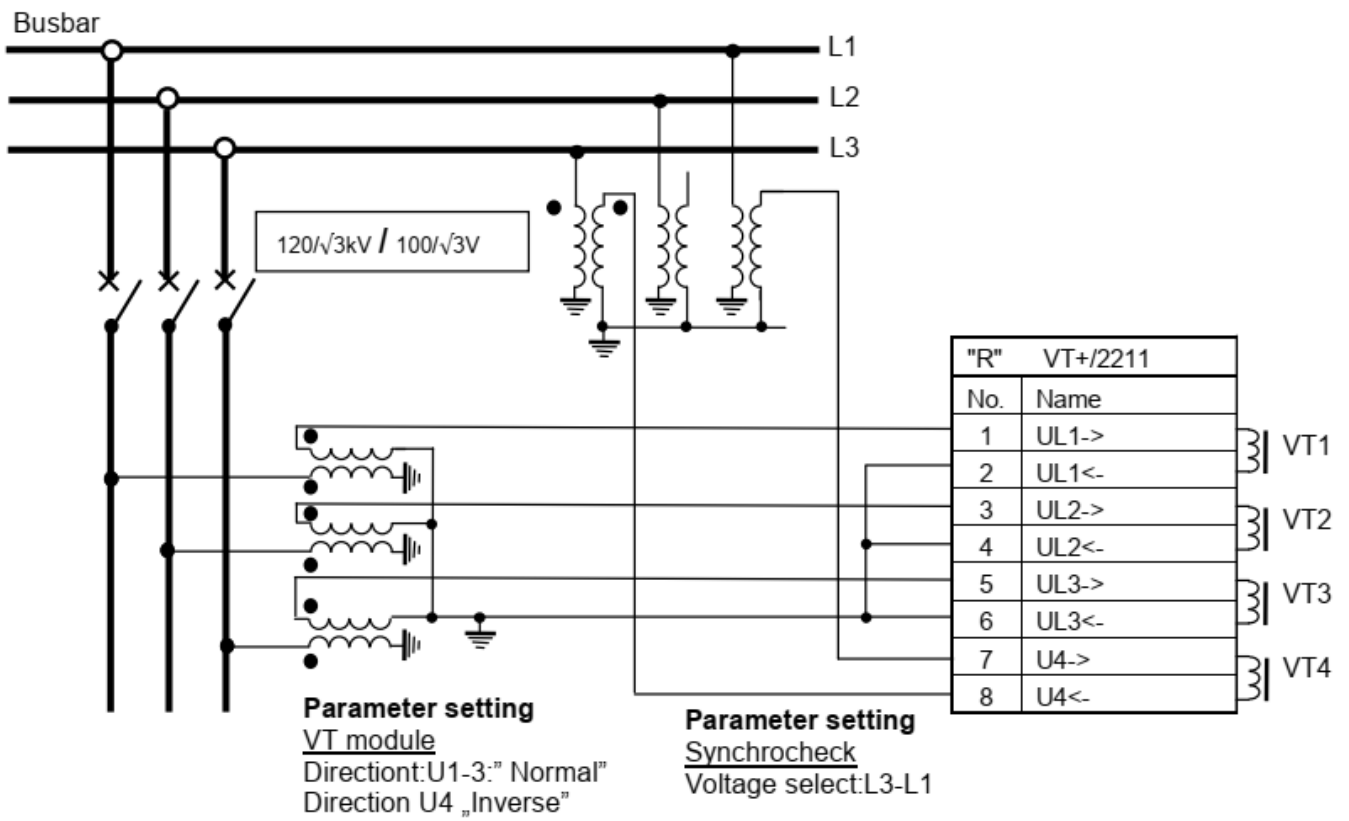

Figure 1-5 Example: Synchrocheck, using phase-to-phase voltage

Figure 1-6 shows the proposed parameter values for the connection shown above.

[-] VT4 module "U"

	Device value (Default_set_1)	New value		
Range	Type 100	Type 100		
Connection U1-3	Ph-N	Ph-N		
Connection U4	Ph-Ph	Ph-Ph		
Direction U1-3	Normal	Normal		
Direction U4	Inverted	Inverted		
VT correction	100	100	%	(100 - 115 / 1)
Rated Primary U1-3	69.28	69.28	kV	(1.00 - 1000.00 / 0.01)
Rated Primary U4	120.00	120.00	kV	(1.00 - 1000.00 / 0.01)

Figure 1-6 Example: Parameters for syncrocheck, using phase-to-phase voltage

The "On-line window" of the VT4 input module shows the checking the correct voltage vector position. When the line is connected to the busbar, i.e. the CB is closed, in this example the U4 voltage is expected to have a vector identical with the voltage difference U3-U1. See Figure 1-7.

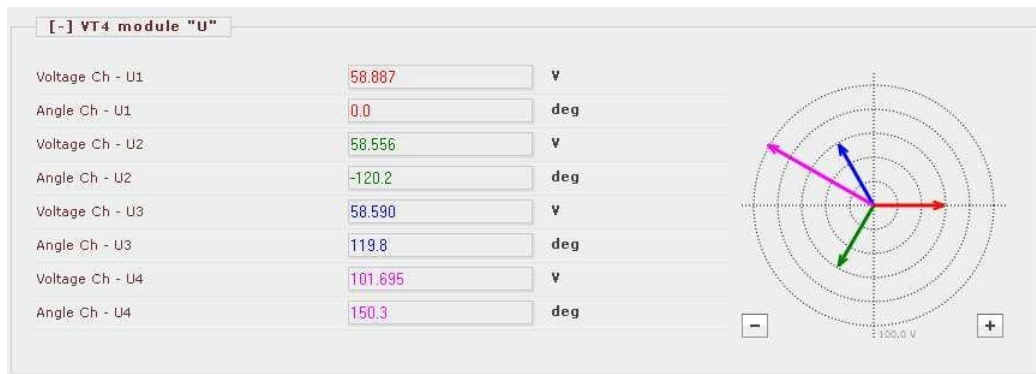
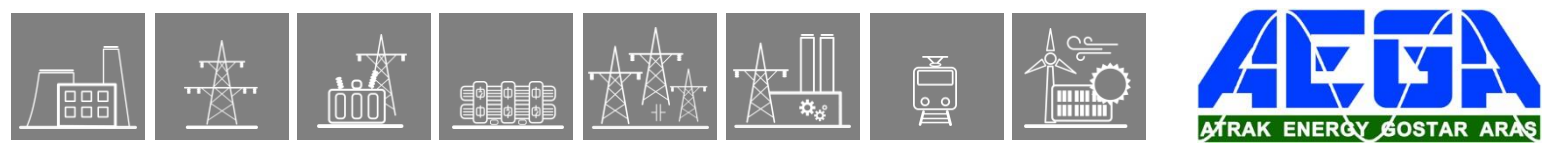

Figure 1-7 Example: On-line measurement for syncrocheck, using phase-to-phase voltage

NOTE that due to the reverse connection of the voltage difference and the parameter setting also reverted by "Inverse" setting, the indicated U4 vector corresponds to the parameter "Voltage select=L3-L1" among syncrocheck parameters.



2.3.4. Line and frequency measurement functions

2.3.4.1. Application

The input values of the EuroProt+ devices are the secondary signals of the voltage transformers and those of the current transformers when they are available in the actual configuration.

These signals are pre-processed by the “VT4 module” voltage input function block and by “CT4 module” the current input function block. These function blocks are described in separate documents. The pre-processed values include the Fourier basic harmonic phasors of the voltages and currents and the true RMS values. Additionally, it is in these function blocks that parameters are set concerning the voltage ratio of the primary voltage transformers and current ratio of the current transformers.

Based on the pre-processed values and the measured transformer parameters, the measurement function blocks calculate - depending on the hardware and software configuration - the primary RMS values of the voltages and currents and some additional values such as active and reactive power, symmetrical components of voltages and currents. These values are available as primary quantities and they can be displayed on the on-line screen of the device or on the remote user interface of the computers connected to the communication network and they are available for the SCADA system using the configured communication system.

2.3.4.2. Mode of operation

The **inputs** of the line measurement function are

- the Fourier components and true RMS values of the measured voltages and currents,
- frequency measurement,
- parameters.

The **outputs** of the line measurement function are

- displayed measured values,
- reports to the SCADA system.

NOTE: the scaling values are entered as parameter setting for the “Voltage transformer input” function block and for the “Current transformer input” function block.

2.3.4.3. The measurement

2.3.4.3.1. The measured values; variants of the function

There are six variants of the MXU function, based on their **measured values**. Parameters and measurements are alike for each. The **type of the variant** is shown in the *function block name*:

- Line Measurement (*MXU_LM*)
- Frequency Measurement (*MXU_F*)
- Voltage measurement (*MXU_V*)
- Voltage measurement (*MXU_V1*) (single voltage)
- Current measurement (*MXU_C*)
- Current measurement (*MXU_C1*) (single current)

Table 1-1 Measured values of each variant

ON-LINE MEASURED VALUE	EXPLANATION	MXU FUNCTION BLOCK VARIANT					
		LM	F	V	V1	C	C1
MXU_P_OLM_	Active Power – P (Fourier base harmonic value)	X					
MXU_Q_OLM_	Reactive Power – Q (Fourier base harmonic value)	X					
MXU_S_OLM_	Apparent Power – S (Fourier base harmonic value)	X					
MXU_Fi_OLM_	Power factor	X					
MXU_I1_OLM_	Current L1	X				X	X
MXU_I2_OLM_	Current L2	X				X	
MXU_I3_OLM_	Current L3	X				X	
MXU_Ipos_OLM_	Calculated positive seq. current	X				X	
MXU_Ineg_OLM_	Calculated negative seq. current	X				X	
MXU_3Io_OLM_	Calculated 3Io	X				X	
MXU_U1_OLM_	Voltage L1	X		X	X		
MXU_U2_OLM_	Voltage L2	X		X			
MXU_U3_OLM_	Voltage L3	X		X			
MXU_U12_OLM_	Voltage L12	X		X			
MXU_U23_OLM_	Voltage L23	X		X			
MXU_U31_OLM_	Voltage L31	X		X			
MXU_Upos_OLM	Calculated positive seq. voltage	X		X			
MXU_Uneg_OLM_	Calculated negative seq. voltage	X		X			
MXU_3Uo_OLM_	Calculated 3Uo	X		X			
MXU_f_OLM_	Frequency		X	X			

2.3.4.4.2. “Integrated” mode of reporting

If the “Integrated” mode is selected for reporting, a report is generated if the time integral of the measured value since the last report gets becomes larger, in the positive or negative direction, then the (deadband*1sec) area. As an example, [Figure 1-2](#) shows that the integral of the current in time becomes higher than the Deadband value multiplied by 1sec, this results “report2”, etc.

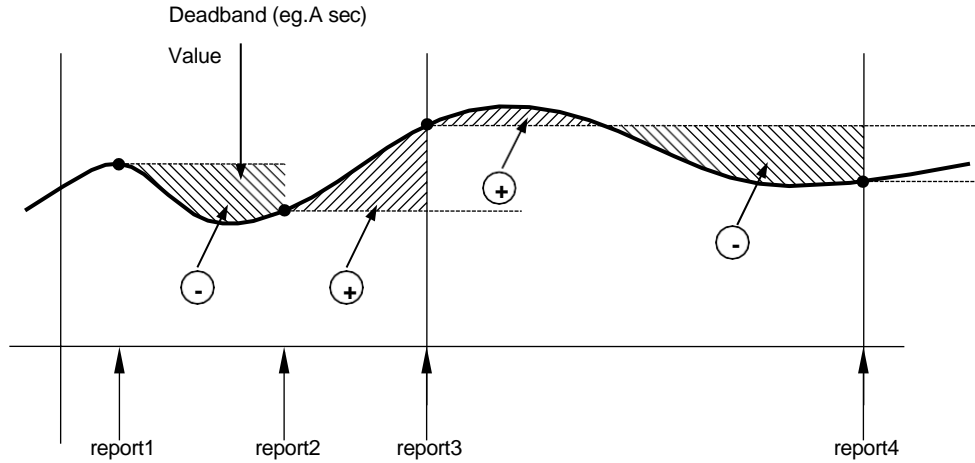

Figure 1-2 Reporting if “Integrated” mode is selected

2.3.4.4.3. Periodic reporting

Periodic reporting is generated independently of the changes of the measured values when the defined time period elapses. If the reporting time period is set to 0, then no periodic reporting is performed for this quantity.

Applying periodic reporting and setting up its interval is done by using the **Communication configurator**, a part of the **EuroCAP** software (see its description for detailed information).

Once the “Trigger period” property is set to “True”, the “Integrity period” setting becomes available to set (in milliseconds). As an example, see the picture below.

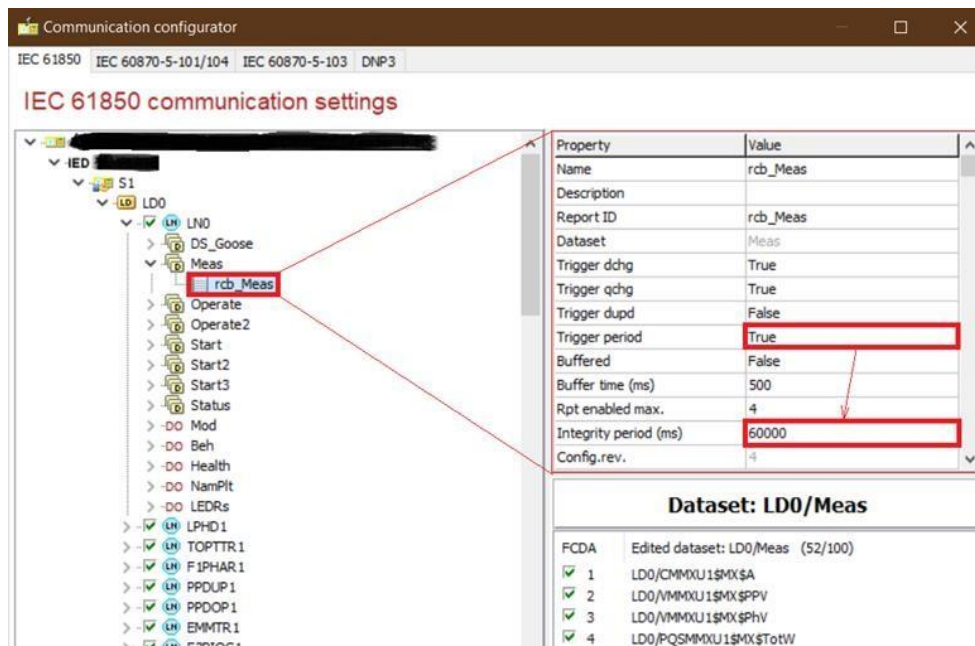
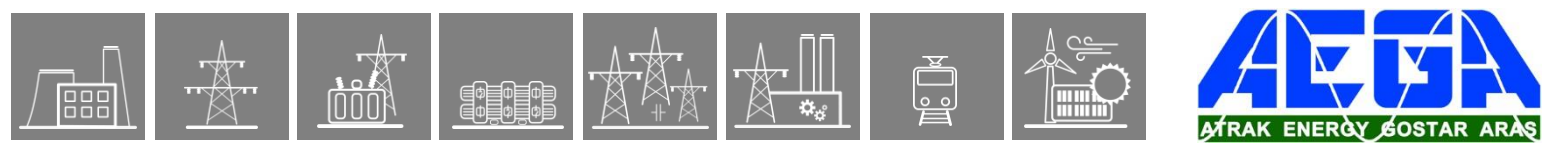

Figure 1-3 Setting up periodic reporting in EuroCAP



2.3.4.4.4. Zero-point clamping

A measured value under the zero-point clamping limit is cut off to zero.

- Three-phase current measurement 0.2% of nominal (I_n)
- Three-phase voltage measurement 2% of nominal (U_n)
- Residual current measurement 0.2% of nominal (I_n)
- Residual voltage measurement 2% of nominal (U_n)
- Phase sequence current measurement 0.2% of the nominal (I_n)
- Phase sequence voltage measurement 2% of the nominal (U_n)
- Three-phase power and energy measurement 0.23% of the nominal (S_n)

Range Value - Ipos	A	1 – 5000	1	500	Range value for the positive seq. current
Report Deadband - P	-	Off, Amplitude, Integrated	-	Amplitude	Selection of the reporting mode for active power measurement
Deadband Value - P	kW*	0.10 – 10000.00	0.01	10	Deadband value for the active power
Range Value - P	kW*	1.00 – 100000.00	0.01	500	Range value for the active power
Report Deadband - Q	-	Off, Amplitude, Integrated	-	Amplitude	Selection of the reporting mode for reactive power measurement
Deadband Value - Q	kVAr*	0.10 – 10000.00	0.01	10	Deadband value for the reactive power
Range Value - Q	kVAr*	1.00 – 100000.00	0.01	500	Range value for the reactive power
Report Deadband - S	-	Off, Amplitude, Integrated	-	Amplitude	Selection of the reporting mode for apparent power measurement
Deadband Value - S	kVA*	0.10 – 10000.00	0.01	10	Deadband value for the apparent power
Range Value - S	kVA*	1.00 – 100000.00	0.01	500	Range value for the apparent power
Report Deadband	Hz	Off, Amplitude, Integrated	-	Amplitude	Selection of the reporting mode for frequency measurement
Deadband Value	Hz	0.01 – 1.00	0.01	0.03	Deadband value for the frequency
Range Value	Hz	0.05 – 10.00	0.01	5	Range value for the frequency

**the prefixes can change (i.e. kW→MW, kV→V etc.) depending on the configuration; changing these is done by Protecta personnel*

***if the setting range is to be extended, contact Protecta personnel*

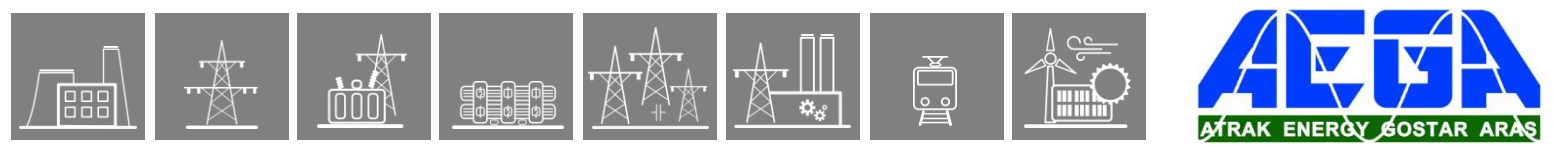

2.3.4.5.2. Function I/O

This section describes briefly the analogue and digital inputs and outputs of the function block.

2.3.4.5.2.1. Analogue inputs

The analogue inputs of the measurement functions are

- the Fourier components and true RMS values of the measured and calculated secondary voltages
- the Fourier components and true RMS values of the measured secondary currents,

2.3.4.5.2.2. Analogue outputs (measurements)

See the next chapter (On-line data) for the listing of all measurements. Note again, that the measured values depend on the type of the actual measurement function block, see Chapter [1.3.1](#)

2.3.4.5.2.3. On-line data

The **on-line data** of the line measurement function depend on the available analogue values which are referring to the applied hardware configuration.

Visible values on the on-line data page:

Table 2-2 On-line data of the line measurement function

SIGNAL TITLE	DIMENSION	EXPLANATION
Power - P	kW*	Calculated three-phase active power
Reactive Power - Q	kVAr*	Calculated three-phase reactive power
Apparent Power - S	kVA*	Calculated three-phase apparent power
Power factor	-	Calculated power factor
Current L1	A	Measured primary current L1 based on the nominal values of the CT4 current input function
Current L2	A	Measured primary current L2 based on the nominal values of the CT4 current input function
Current L3	A	Measured primary current L3 based on the nominal values of the CT4 current input function
Positive sequence current	A	Calculated positive sequence current from the three phase currents
Negative sequence current	A	Calculated negative sequence current from the three phase currents
Calculated 3I ₀	A	Calculated 3I ₀ from the three phase currents
Voltage L1	kV*	Measured primary L1 phase voltage L1 based on the nominal values of the VT4 voltage input function
Voltage L2	kV*	Measured primary L2 phase voltage L2 based on the nominal values of the VT4 voltage input function
Voltage L3	kV*	Measured primary L3 phase voltage L3 based on the nominal values of the VT4 voltage input function
Voltage L12	kV*	Calculated L12 phase-to-phase voltage
Voltage L23	kV*	Calculated L23 phase-to-phase voltage
Voltage L31	kV*	Calculated L31 phase-to-phase voltage
Positive sequence voltage	kV*	Calculated positive sequence voltage from the three phase voltages
Negative sequence voltage	kV*	Calculated negative sequence voltage from the three phase voltages
Calculated 3U ₀	kV*	Calculated 3U ₀ from the three phase voltages
Frequency	Hz	Measured frequency

**the prefixes may be different (i.e. kW→MW, kV→V etc.) depending on the configuration; changing these is done by Protecta personnel*

2.3.5.4. Parameters of the function block

Enumerated parameter

Parameter name	Title	Selection range	Default
Time window for averaging			
MXU_TimWin_EPar_T _	Average TimeWindow	Off,5min,10min,15min,30min,60min	Off

Table 1-1 The enumerated parameters of the average and maximum measurement function

Integer parameter

Parameter name	Title	Unit	Min	Max	Step	Default
Time window for finding the maximum value						
MXU_MaxResInt_IPar_T	MaxReset Interval	day	0	365	1	1
Moment of time for reporting and reset						
MXU_MaxResTime_IPar_T	MaxReset Time	hour	0	23	1	12

Table 1-2 The integer parameters of the average and maximum measurement function

2.3.5.5. Status signals of the function block

The average and maximum measurement function block has **binary input signals**, which serve the purpose of resetting the values and enabling logging the average value. **The conditions are defined by the user, applying the graphic equation editor.**

Binary status signal	Explanation
MXU_Reset_GrO_IL1 *	This signal resets both the calculated average and the found maximum value. At the end of the running cycles, the values found during the shortened cycle will be processed.
MXU_DemHMIEna_GrO_IL1	During the active state of this signal also the calculated average value is logged

* Note: In this example “IL1” is indicating that in the instant of the function block processes the RMS value of the current in line 1

Table 1-3 The binary input signal for the average and maximum measurement function block

The average and maximum measurement function block **has no binary output signals.**

2.3.5.6. The function block

The function block of the average and maximum measurement function is shown in Figure 1-1. This block shows all binary input (and output) status signals that are applicable in the graphic equation editor.

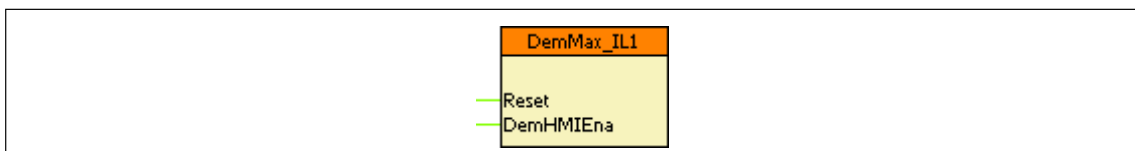
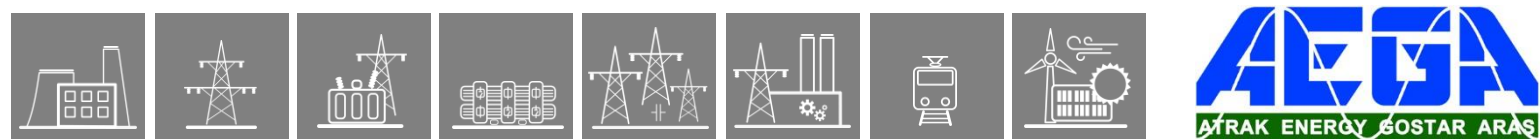

Figure 1-1 The function block of the average and maximum measurement function block



2.3.6.1.3. Impulse mode

Based on the external energy meter impulses. These impulse outputs of the meter connect as binary inputs. Metering function block calculates the active and reactive power supply and demand. These values are accumulated to obtain, separately:

- Active power demand,
- Active power supply,
- Reactive power demand.
- Reactive power supply,

Impulse scaling values are entered as parameters named “Active pulse scale” and “Reactive pulse scale”.

The time period of the accumulation is defined by parameter setting. It can be selected in a broad range. The start of the accumulation is based on the integrated real-time clock of the device. For example, for the “Time Interval” setting of 15min, the trigger is: at 0h0min, 0h15min, 0h30min, 0h45 min, 1h0min, etc.

When the accumulation time is over, the calculated values are reported to the SCADA system. The displayed values change continuously.

The calculated values are available as primary quantities and they can be displayed on the on-line screen of the device or on the webpage of the device and they are available for the SCADA system using the configured communication system

The **inputs** of the metering function are:

- the impulses of energy meter,
- parameters.

The **output** of the metering function is:

- displayed measured values.

2.3.6.1.4. Cumulation mode

“Cumulation mode” parameter defines the mode of operation. It can be “TRUE” or “FALSE”.

In “FALSE” mode the values set to zero after the values are reported to the SCADA system, based on the “Time Interval” settings.

In “TRUE” mode the values are cumulated after the report is sent to the SCADA system.

Maximum cumulated value depends on the CT module of IED and the primary nominals of CT and VT.

“Nominal primary power” = “Rated Primary U1-3” setting of VT module multiplied by “Rated Primary I1-3” setting of CT module. Unit prefix (kilo- or Mega) depends on the configuration, the “Line measurement” function uses the same unit prefix as Metering.

Maximum cumulated power value with CT+/1500 module = 3 259 602 multiplied by “Nominal primary power”

Maximum cumulated power value with CT+/5151 module = 65 192 055 multiplied by “Nominal primary power”

Maximum cumulated power value with CT+/5115 module = 8 149 006 multiplied by “Nominal primary power”

User can reset cumulated value to zero either by initiating the reset input of Metering function block or by restarting the device.

2.3.6.1.5. The measurement

2.3.6.1.5.1. Reference direction

“Reference direction” parameter setting defines the direction when voltage and current vectors are in phase. Setting can be “Demand” or “Supply”.

2.3.6.1.5.2. The measured values

Unit prefix of the **measured values** of the metering function depends on the configuration: it can be kilo or Mega. The “Line measurement” function uses the same unit prefix as the Metering.

MEASURED VALUE	EXPLANATION
MTR_PosP_OLM_	Demand kWh – active power consumption
MTR_NegP_OLM_	Supply kWh – active power supply
MTR_PosQ_OLM_	Demand kVArh – reactive power consumption
MTR_NegQ_OLM_	Supply kVArh – reactive power supply

Table 1-1 Measured values of the metering function

The measured values available are shown as on-line information, see the figure below.



[-] METERING		
Demand kWh	400.0	kWh
Supply kWh	300.0	kWh
Demand kVArh	500.0	kVArh
Supply kVArh	2500.0	kVArh

Figure 1-1 Measured values of the metering function

2.3.6.1.6. Parameter setting

The time period of accumulation is defined by parameter setting. This can be selected in a broad range, as it is shown in Table 1-2.

Enumerated parameter

PARAMETER NAME	TITLE	SELECTION RANGE	DEFAULT
Selection of the time period for power metering			
MTR_TimInt_EPar_	Time Interval	Off, 5min, 10min, 15min, 30min, 60min	30min

Table 1-2 The enumerated parameter of the metering function

2.3.6.2. Metering function overview

The graphic appearance of the function block of the metering function is shown below. The block shows all binary input and output status signals which are applicable in the graphic equation editor.

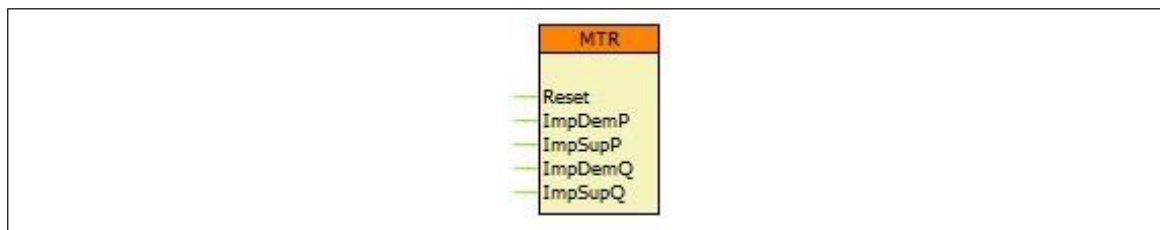

Figure 2-1 Graphic appearance of the function block of the metering function

2.3.6.2.1. Settings

2.3.6.2.1.1. Parameters

The available parameters are listed below in order of their appearance in the *parameters* menu. If the setting range of a parameter should be extended, contact Protecta Support.

Table 2-1 The available parameters of the metering function

TITLE	DIM.	RANGE	STEP	DEFAULT	EXPLANATION
Time Interval	-	Off, 5min (On), 10min , 15min , 30min , 60min	-	30min	Time period of accumulation parameter for general operation of the function:
Input selection	-	Measurement, Impulse,	-	Measurement	Input selection of energy calculation
Cumulation mode		FALSE,TRUE		FALSE	Cumulation mode is used
Reference direction	-	Demand, Supply	-	Demand	Energy direction reference selection.
Active pulse scale	kWh/ pulse	1 - 10000	1	100	One impulse of energy meter is equal to this setting
Reactive pulse scale	kVarh/ pulse	1 - 10000	1	100	One impulse of energy meter is equal to this setting

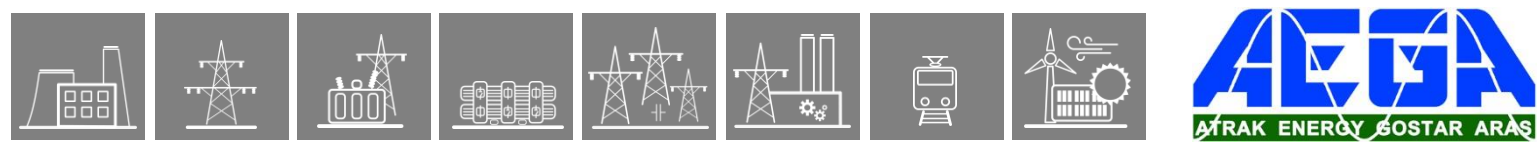

2.3.6.2.2. Function I/O

This section describes briefly the analogue and digital inputs and outputs of the function block.

2.3.6.2.2.1. Analogue inputs

The function uses the sampled values of a voltage and current inputs. This is defined in the configuration.

2.3.6.2.2.2. Analogue outputs (measurements)

The measured values of the metering function are listed in the table below.

Table 2-2 The measured analogue values of the metering function

MEASURED VALUE	DIMENSION	EXPLANATION
Demand P	kWh	<i>Demand P. Unit prefix can be kilo- or mega-, depends on the configuration</i>
Supply P	kWh	<i>Supply P. Unit prefix can be kilo- or mega-, depends on the configuration</i>
Demand Q	kVArh	<i>Demand Q. Unit prefix can be kilo- or mega-, depends on the configuration</i>
Supply Q	kVArh	<i>Supply Q. Unit prefix can be kilo- or mega-, depends on the configuration</i>

2.3.6.2.2.3. Binary input signals (graphed output statuses)

The conditions of the binary inputs are defined by the user, applying the graphic equation editor (*Logic Editor*). Parts written in **bold** are seen on the left side function block in the Logic editor.

Table 2-3 The binary input signal of the metering function

BINARY OUTPUT SIGNAL	EXPLANATION
MTR_Reset_GrO_	Reset input of the function has meaning only in cumulation mode
MTR_ImpDemP_GrO_	Demand P impulse of external energy meter input of the function has meaning only in impulse input mode
MTR_ImpSupP_GrO_	Supply P impulse of external energy meter input of the function has meaning only in impulse input mode
MTR_ImpDemQ_GrO_	Demand Q impulse of external energy meter input of the function has meaning only in impulse input mode
MTR_ImpSupQ_GrO_	Supply Q impulse of external energy meter input of the function has meaning only in impulse input mode

2.3.6.2.2.4. Events

The following events are generated in the event list, as well as sent to the SCADA according to the configuration.

Table 2-4 Generated events of the metering function

EVENT	DIMENSION	EXPLANATION
Demand P	Wh	<i>Demand P value</i>
Supply P	Wh	<i>Supply P value</i>
Demand Q	VArh	<i>Demand Q value</i>
Supply Q	VArh	<i>Supply Q value</i>

2.3.6.2.3. Technical data

Table 2-5 Technical data of the metering function

FUNCTION	RANGE	ACCURACY
Power accuracy	$I > 15\%I_n$	$\pm 3\%$

2.3.6.2.4. Notes for testing

Time period of the accumulation is defined by parameter setting.

Starting accumulation is based on the integrated real-time clock of the device.

For example, for a “Time Interval” setting of 15min, the trigger is: at 0h0min, 0h15min, 0h30min, 0h45 min, 1h0min, etc.

Parameter changing resets the accumulation. Using the settings of the example above, setting new parameters at 0h07min will result in the following:

- the accumulated values are reset to zero,
- the new accumulation starts at 0h15min,
- the first report is sent at 0h30min. Measured values in Events list will also refresh at 0h30min.

2.3.6.2.5. 61850 LN

Instance number of Logical Node is not mentioned in the table below.

Table 2-6 Logical Node and Data Objects of the metering function

LN NAME	DO NAME	DA NAME	FC	EXPLANATION
EMMTR	DmdVArhPV	mag.f	MX	<i>Demand VArh value</i>
		q	MX	<i>quality</i>
		t	MX	<i>timestamp</i>
	DmdWhPV	mag.f	MX	<i>Demand Wh value</i>
		q	MX	<i>quality</i>
		t	MX	<i>timestamp</i>
	SupVArhPV	mag.f	MX	<i>Supply VArh value</i>
		q	MX	<i>quality</i>
		t	MX	<i>timestamp</i>
	SupWhPV	mag.f	MX	<i>Supply Wh value</i>
		q	MX	<i>quality</i>
		t	MX	<i>timestamp</i>

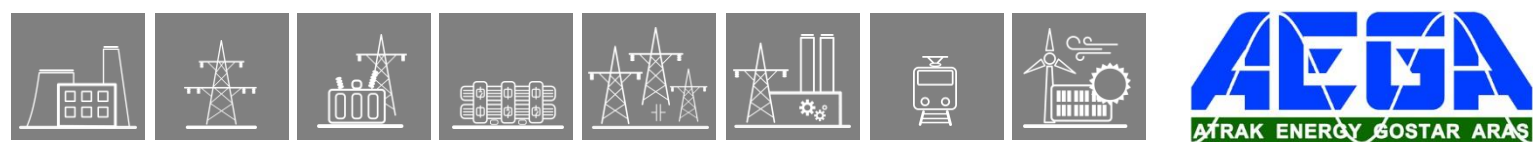

2.3.7. Voltage selection function block

2.3.7.1. Application

In several substation configurations with double busbar, there is no voltage measurement in the bays, but voltage transformers are connected to the busbars only.

If the protection functions configured in the bay devices apply voltage measurement then the correct selection of the voltage sources is needed. The role of the voltage selection is that the protection functions get the voltage of the busbar section to which the feeder or the transformer is connected.

To solve this problem the device gets both three-phase voltages of both busbar sections, and a binary signal decides which one is valid for the protection function.

The “Voltage selection” function block assigns the correct voltages to the protection functions.

2.3.7.2. Mode of operation

The voltage selection is decided by a binary signal. **The conditions are defined by the user applying the graphic equation editor.**

If this input signal is FALSE then the voltages of the voltage input module configured as default input are assigned to the protection functions.

If however this input signal is TRUE then the voltages of the other voltage input module are assigned to the protection functions.

2.3.7.3. The binary status signals

The voltage selection function block has a binary input signal. **The conditions are defined by the user applying the graphic equation editor.**

The **binary input status signal** of the voltage selection function block is shown in Table 1-1.

Binary status signal	Title	Explanation
SelectVolt_USelect_GrO_	USelect	Binary signal controlling the voltage selection

Table 1-1 The binary input status signal of the voltage selection function block

The **binary output status signals** of the voltage selection function block. The voltage selection function block has no binary output status signals.

2.3.7.4. The parameters

The voltage selection function block has no parameters.

2.3.7.5. The symbol of the function block in the graphic editor

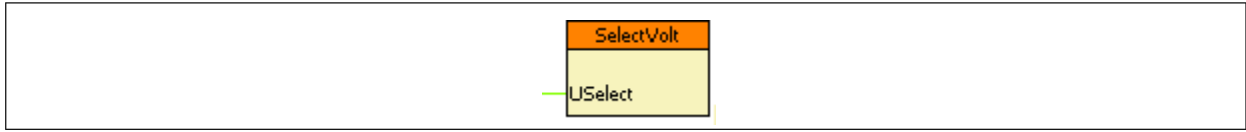

Figure 1-1 The function block of the voltage selection function block

The name of the input signal is a part of the “Binary status signal” name shown in Table 1-1.

2.3.7.6. Example

In this simple example the channel No.1 of the binary input module in position “F” is used as the signal controlling the selection.

If this input signal is FALSE then the voltages of the voltage input module configured as default input are assigned to the protection functions.

If however this input signal is TRUE then the voltages of the other voltage input module are assigned to the protection functions.

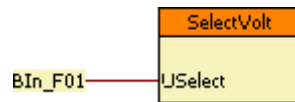
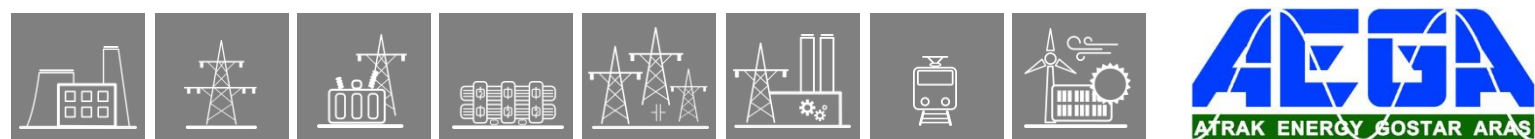

Figure 2-1 Example The simple application of the voltage selection function block



2.3.8. Trip Value Recorder

2.3.8.1. Application

For quick evaluating of network faults, it is very useful to see in the event list of the protection device the measured primary analog values (currents, voltages) before and during the fault state. The Trip value recorder function serves this purpose.

This function is not a default element of any configuration, but it can be acquired (please contact Protecta Support team).

2.3.8.1.1. The measurement

The input values of the EuroProt+ devices are the secondary signals of the voltage transformers and those of the current transformers.

These signals are pre-processed by the “Voltage transformer input” function block and by the “Current transformer input” function block. These function blocks are described in separate documents. The pre-processed values include the Fourier basic harmonic phasors of the voltages and currents and the true RMS values. Additionally, it is in these function blocks that parameters are set concerning the voltage ratio of the primary voltage transformers and current ratio of the current transformers.

Based on the pre-processed analogue signals, several function blocks perform additional calculation, e.g.: active and reactive power, frequency, temperature, impedances, higher harmonics, symmetrical components, etc.

The Trip value recorder function calculates the primary values from its three input secondary signals (currents or voltages) and uses them as described in the following chapter.

2.3.8.1.2. Operation principles

The Trip value recorder has two binary inputs: “Start” and “Trip”.

When the “Start” binary input receives a rising edge signal, the function stores the pre-fault value of the three analogue signals and the fault value of the three analogue signal as well and the function starts waiting for the trigger (Trip) signal. If no trigger signal coming and new start signal receives the stored pre-fault and fault values will be overwritten by the latest ones.

The “Trip” binary input of the function is applied for triggering the trip value recording to generate the events with the pre-fault and fault values.

After triggering the function, so the “Trip” binary input is activated, the function generates the following values in the event list and sends them automatically to the SCADA system:

- pre-fault values of the three analog signals 100 ms before the Start signal receives,
- fault values of the three analog signals: average of the values 10 ms and 20 ms after the Start.

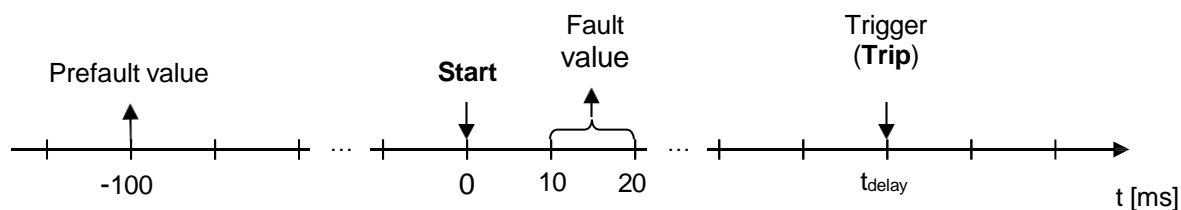

Figure 1-1 Time diagram of the trip recording behaviour

2.3.8.2. Trip value recorder function overview

The graphic appearance of the function block of the trip value recorder function is shown below. The block shows all binary input and output status signals which are applicable in the graphic equation editor.

Usually, the collected general start signal of the protection functions is assigned to the “Start” input and the general trip signal of trip logic function is connected to the “Trip” input.

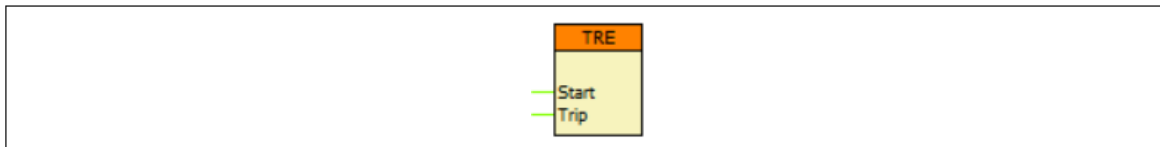

Figure 2-1 Graphic appearance of the function block of the trip value recorder function

2.3.8.2.1. Settings

2.3.8.2.1.1. Parameters

The Trip value recorder function does not have any parameters.

2.3.8.2.2. Function I/O

This section describes briefly the analogue and digital inputs and outputs of the function block.

2.3.8.2.2.1. Analogue inputs

The function uses the sampled values of a current input or voltage input. Moreover, calculated analogue signals i.e.: symmetrical values, differential/bias current values can be used as inputs.

The following table contains the available input channels of the trip value recorder function.

Table 2-1 Available analogue inputs of the trip value recorder function

ANALOGUE INPUTS	RELATED FUNCTION BLOCK
Phase current, phase-to-phase, symmetrical, residual currents	CT4, CalcCurr
Voltage in phase, phase-to-phase, and symmetrical; Reference (busbar) voltages	VT4, CalcVolt
Calculated Idiff/Ibias current of transformer differential protection	DIF87T
Calculated Idiff/Ibias current of busbar differential protection for each bus section	DIF87B

NOTE: Displaying the fault current values of the line differential protection Idiff/Ibias current and the restricted earth fault protection Idiff/Ibias current are integrated into the protection function, thus not need additional trip value functions to display the trip values.

2.3.8.2.2.2. Binary input signals (graphed output statuses)

The conditions of the binary inputs are defined by the user, applying the graphic equation editor (*Logic Editor*). Parts written in **bold** are seen on the left side function block in the Logic editor.

Table 2-2 The binary input signal of the trip value recorder function

BINARY OUTPUT SIGNAL	EXPLANATION
TRE_Start_GrO_	Dedicated input of the function to receive the start signal of the selected protection functions
TRE_Trip_GrO_	Dedicated input of the function to receive the trip signal of the selected protection functions

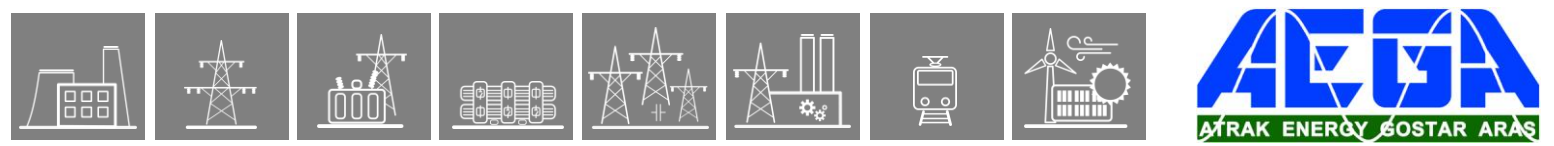

2.3.8.2.2.3. Binary output signals (graphed input statuses)

The Trip value recorder function does not have any binary output signals.

2.3.8.2.2.4. Online data

No default visible values on the *online data* page.

2.3.8.2.2.5. Events

The following events are generated in the event list, as well as sent to the SCADA according to the configuration.

Table 2-3 Generated events of the trip value recorder function

EVENT	VALUE	EXPLANATION
... Prefault*	according to the applied input	Prefault value of the applied signal
... Fault*	according to the applied input	Fault value of the applied signal

**The event text may vary according to the actual device configuration (.epcs)*

2.3.9. RTD temperature input function

2.3.9.1. Application of the RTD input

If the factory configuration includes an RTD temperature input hardware module, the temperature input function block is automatically configured among the software function blocks. Separate temperature input function blocks are assigned to each temperature input hardware module.

The RTD+1100 temperature input hardware module is equipped with four special input channels, the RTD+ 0200 has a single channel only. (See EuroProt+ hardware description document.) To each channel, a temperature sensor can be connected. The temperature is measured as the resistance value of the sensor, which depends upon the temperature.

The sensors can be connected by wiring methods, shown in Figure 1–1, Figure 1–2 and Figure 1–3. The connection mode is identified also by parameter setting.

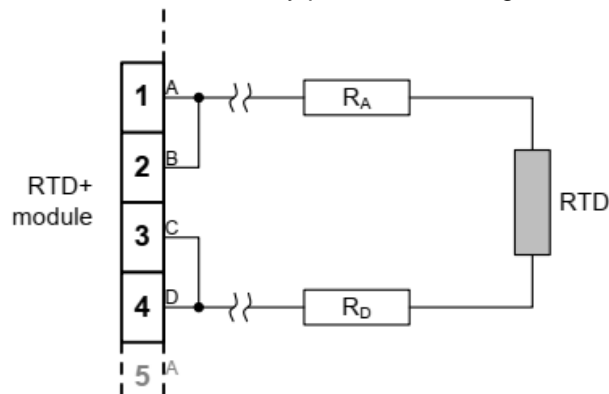

Figure 1–1 2-wire RTD wiring

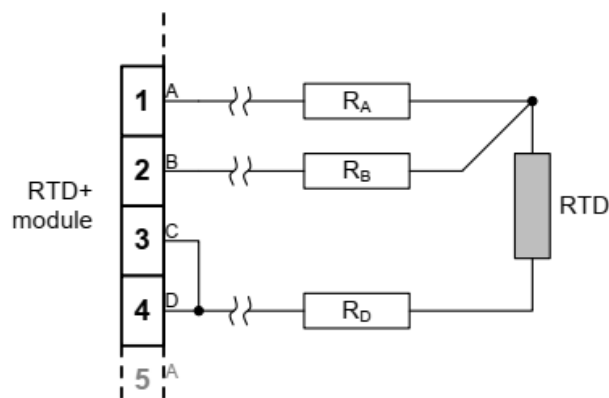

Figure 1–2 3-wire RTD wiring

When 3-wire connection is applied, it is supposed that $R_A=R_D$.

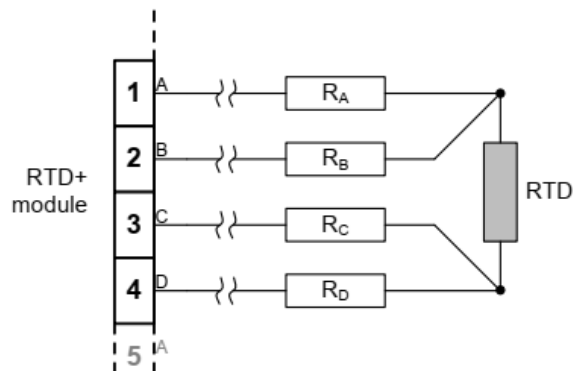
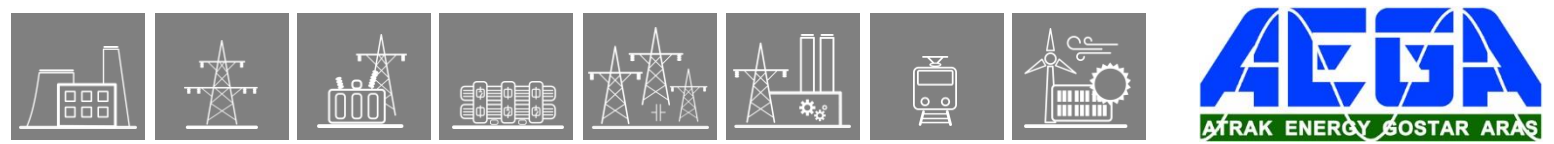

Figure 1-3 4-wire RTD wiring

The channels of the module are independent of each other. To each channel a dedicated measuring module is assigned. These measuring modules are described in a separate document: “**GGIORTD temperature measurement module function block description**”. The module is prepared to connect the following types of sensors:

- Pt100/Ni100
- Ni120/Ni120US
- Pt250/Ni250
- Pt1000/Ni1000
- Cu10
- Service-Ohm (60 Ω ... 1.6 k Ω)

The applied type of sensors define the conversion mode from measured resistance to temperature. These are selected by parameters of the temperature measuring module. See separate document: “**GGIORTD temperature measurement module function block description**”.



2.4. Disturbance recorder function

The disturbance recorder function can record analog signals and binary status signals. These signals are configured using the EuroCAP software tool.

The disturbance recorder function has a binary input signal, which serves the purpose of starting the function. **The conditions of starting are defined by the user, applying the graphic equation editor.** The disturbance recorder function keeps on recording during the active state of this signal but the total recording time is limited by the timer parameter setting.

The pre-fault time, max recording time and post-fault time can be defined by parameters.

2.4.1. Mode of recording

If the triggering conditions defined by the user - using the graphic equation editor – are satisfied and the function is enabled by parameter setting, then the disturbance recorder starts recording the sampled values of configured analog signals and binary signals.

The analog signals can be sampled values (voltages and currents) received via input modules or they can be calculated analog values (such as negative sequence components, etc.)

The number of the configured binary signals for recording is limited to 64, and up to 32 analog channels can be recorded.

The available memory for disturbance records is 12 MB.

There are two function blocks available. The first function (**DRE**) applies 20 sampling in a network period. Accordingly for 50 Hz, the sampling frequency is 1 kHz. (For 60 Hz the sampling frequency is 1.2 kHz). This is used in all configurations by default.

The second function (**DRE2**) is capable to be set by parameter to apply 20 or 40 sampling in a network period. This way accordingly for 50 Hz, the sampling frequency is 1 kHz or 2 kHz (and for 60 Hz the sampling frequency is 1.2 kHz or 2.4 kHz). *Except for this, the two function blocks are the same.*

As an example, for 50 Hz, if the duration of the record is 1000 ms then one analog channel needs about 7 kB and a binary channel needs 2 kB, Using the following formula the memory size can be estimated:

$$\text{Memory size of a record} = (n \cdot 7 \text{ kB} + m \cdot 2 \text{ kB}) \cdot \text{record duration (s)}$$

Here n,m: are the number of analog and binary channels respectively.

During the operation of the function, the pre-fault signals are preserved for the time duration as defined by the parameter “PreFault”.

The recording duration is limited by the parameter “Max Recording Time” but if the triggering signal resets earlier, this section is shorter.

The post-fault signals are preserved for the time duration as defined by the parameter “PostFault”.

During or after the running of the recording, the triggering condition must be reset for a new recording procedure to start.

2.4.2. Format of recording

The records are stored in standard COMTRADE format.

- The configuration is defined by the file .cfg,
- The data are stored in the file .dat,
- Plain text comments can be written in the file .inf.

2.4.3. Downloading and evaluating the disturbance records

The procedure for downloading the records is described in detail in the EuroProt+ manual “Remote user interface description”, Chapter 4.7. The three files are zipped in a file .zip. This procedure assures that the three component files (.cfg, .dat and .inf) are stored in the same location.

The evaluation can be performed using any COMTRADE evaluator software. Protecta offers the “**srEval**” software for this purpose. The application of this software is described in detail in the “srEval manual”. This manual can be downloaded from the following Internet address: http://www.softreal.hu/product/sreval_en.shtml.

2.4.4. Parameters of the disturbance recorder functions

Enumerated parameters

Parameter name	Title	Selection range	Default
Parameter for activation			
DRE_Oper_EPar_	Operation	Off, On	Off
DRE_Resolution_EPar_	Resolution *	1/1.2kHz, 2/2.4kHz	1/1.2kHz

*only on the optional 2/2.4 kHz disturbance recorder function

Table 1-1 The enumerated parameters of the disturbance recorder functions

Timer parameters

Parameter name	Title	Unit	Min	Max	Step	Default
Pre-fault time:						
DRE_PreFault_TPar_	PreFault	msec	100	1000	1	200
Post-fault time:						
DRE_PostFault_TPar_	PostFault	msec	100	1000	1	200
Overall-fault time limit:						
DRE_MaxFault_TPar_	Max Recording Time	msec	500	10000	1	1000

Table 1-2 The timer parameters of the disturbance recorder functions

NOTE: The device goes automatically in “Warning” state and sends a warning message (see [Figure 1-1](#)) if the sum of the pre-fault time and post-fault time is longer than the overall-fault time. The corresponding message in the RDSP log file is: „Wrong DR settings. PreFault + PostFault must be less than MaxFault. Check the parameters.”



Figure 1-1 Warning message if the settings are invalid

2.4.5. The input signals of the disturbance recorder functions

Binary status signals

The disturbance recorder function has a binary input signal, which serves the purpose of starting the function. **The conditions of starting are defined by the user, applying the graphic equation editor.**

Binary status signal	Explanation
DRE_Start_GrO_	Output status of a graphic equation defined by the user to start the disturbance recorder function.

Table 1-3 The binary input signal of the disturbance recorder functions

The recording is performed if the function is enabled by the parameter setting AND the triggering condition as defined by the user is “True” as well.

2.4.6. The function blocks

The two function blocks of the disturbance recorder function is shown in [Figure 1-2](#). The block shows the binary input status signal, which serves the purpose of triggering the record. It is defined by the user in the graphic equation editor.

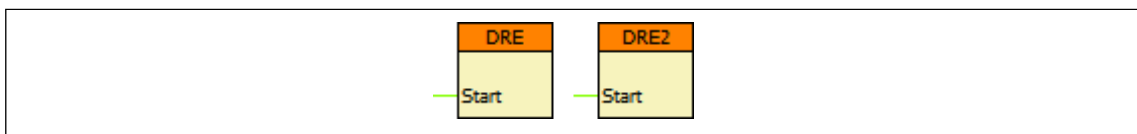

Figure 1-2 The function blocks of the disturbance recorder functions

2.4.7. The recorded signals

The analog and binary signals to be recorded are configured using the EuroCAP software tool in the menu item “Software configuration/Disturbance recorder”. (The access level of the user must be at least “Master”.) The application of this software is described in detail in the EuroCAP manual.



2.5. Event recorder

The events of the device and those of the protection functions are recorded with a time stamp of 1 ms time resolution. This information with indication of the generating function can be checked on the touch-screen of the device in the “Events” page, or using an Internet browser of a connected computer

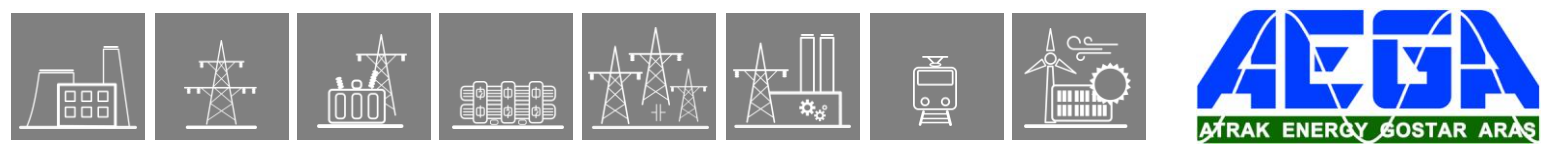

3. Maintenance guide for EuroProt+ devices

3.1. Foreword

The EuroProt+ devices are designed with the most up-to-date and durable components available, to keep appliances in continuous operation for decades. For this range, the only type of components that can age and lead to equipment failure are the power supply capacitors. Therefore, this document, in addition to suggesting some general steps for planned inspections, contains important information on the inspection of power supply modules.

3.2. Safety precautions

The EP+ protection-family, depending on the type, operates at dangerous power supply voltages (220 VDC, 230 VAC, 60 VDC, 48 VDC).



In all cases where the connections of the appliance are to be installed or opened, the work must be carried out by a suitably qualified person.

In all cases, the first step of activity should be to switch off the power



The EuroProt+ protection family has a high operating internal temperature. Operations carried out immediately after operation may lead to dangerous burns.



The hardware and software of the EP+ protection family form a complex system. Setting, modifying, and mounting the individual components may severely affect the operation of the whole system.

In all cases where the device is to be operated or maintained, the activity must be carried out by qualified personnel only

3.2.1. General guidelines for a scheduled maintenance of EP+ devices

1. As a first step, it is recommended to send an email attaching a report.zip file to the Protecta Application Department on the email address application@protecta.hu. In the report file, the logs contain information that can indicate abnormal operation of a module before it causes an operational fault. Based on this information, Protecta can make recommendations for the replacement or repair of the modules concerned.



The report.zip file can be downloaded from the device's web interface, in the Backup / Report section of the Advanced / Status / Log menu, by pressing the "Get file" button. Attention! The file size should be about 700kB. If the downloaded file size is significantly smaller than this, please try again or contact Protecta's Application Department via our web-based support system (<https://support.protecta.hu/?language=English>)!

2. It is usually recommended to update the firmware of the devices during scheduled maintenance. Information about the new firmware releases can be found in the [Release Notes on the Protecta homepage](#). The information here can be used to consider upgrading the basic software for a single device, or all devices in a substation.



Before starting the upgrade, always contact the Protecta Application Department or submit a ticket in the web-based support system from the following link: <https://support.protecta.hu/>

For more details on the firmware update, please refer to Chapter 4.2.10.4 of the [EuroProt+ Operating Manual](#).

3.3. Power supply maintenance

Power supplies are designed with the longest possible life electrolytic capacitors. Their expected lifetime depends significantly on the environmental conditions of the device. During a scheduled inspection, we recommend visual inspection of the power supply for any abnormalities in the capacitors. The most common phenomena are: bloating, electrolyte leakage, discoloration, which typically occurs on capacitors, but can also occur on the surface of the PCB board due to leakage. In case of abnormality, the capacitors should be replaced. In such a case, please contact Protecta's Application Department via our support page (<https://support.protecta.hu/>)!

The following figures illustrate the different capacitor states in several photos.



Figure 4-1 The capacitor on the right is already discolored

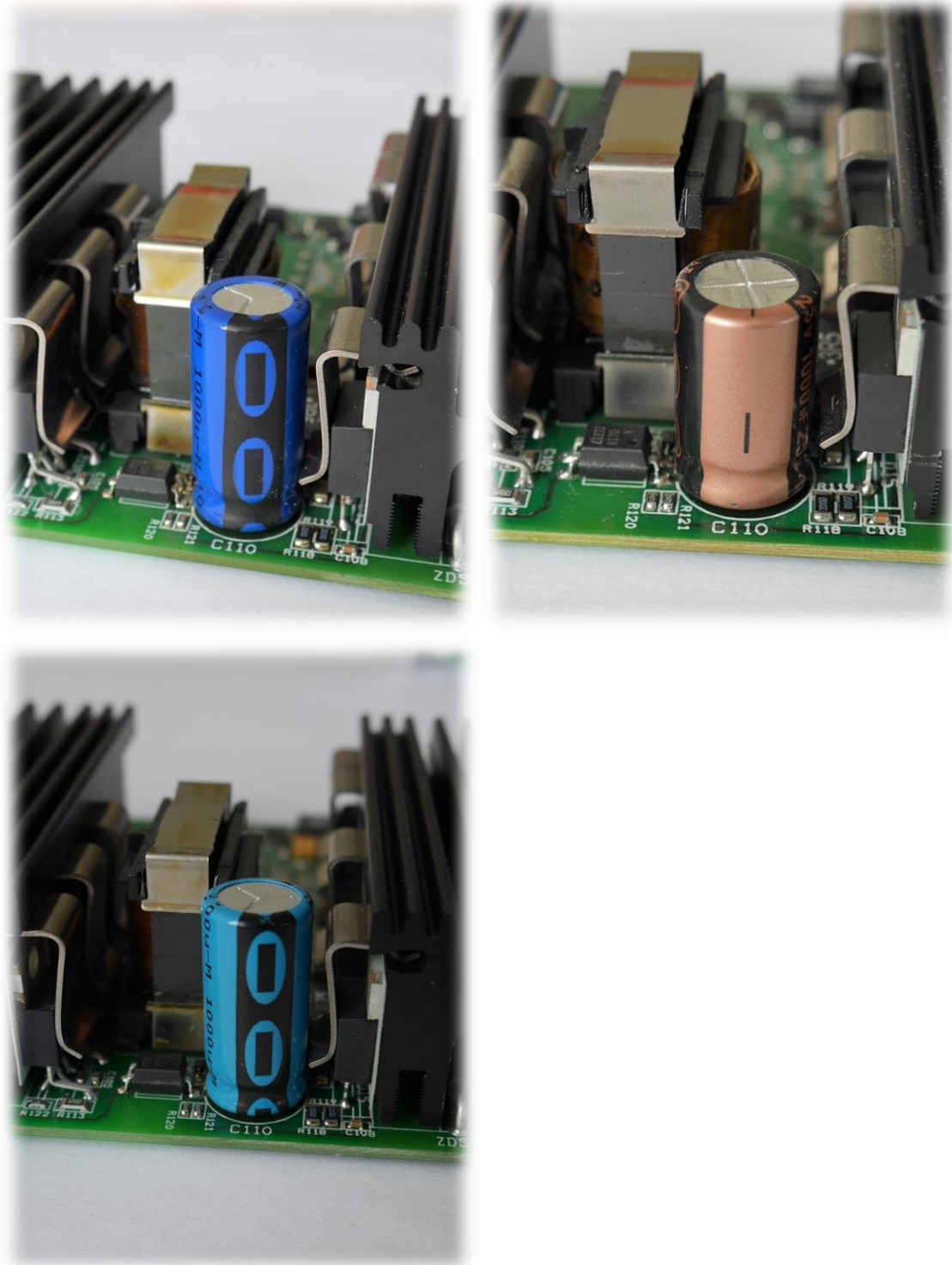

Figure 4-2 Healthy capacitors on visual inspection

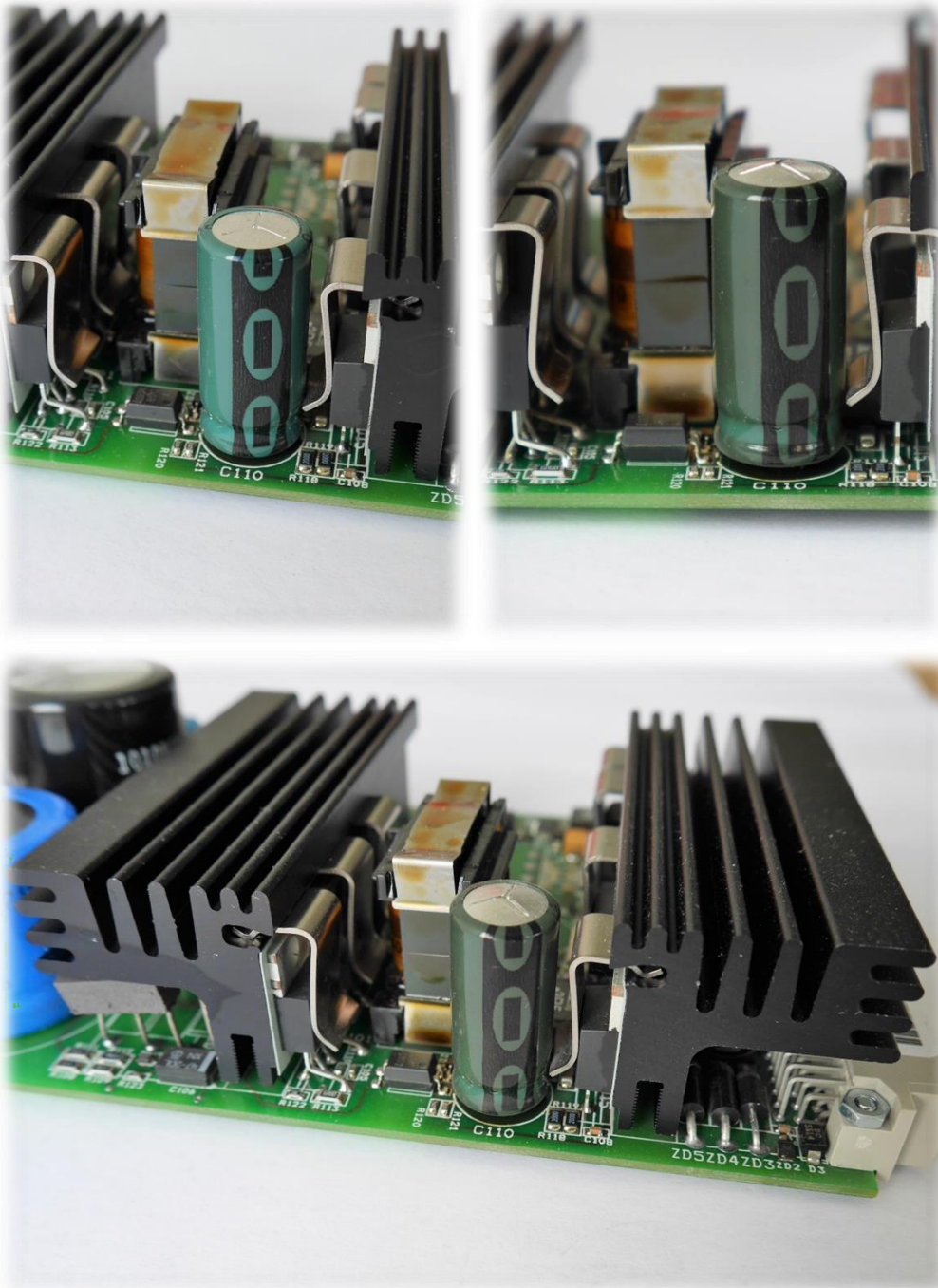

Figure 4-3 Faulty capacitances on visual inspection. The discoloration compared to the original blue color is clearly visible, bloating can be seen on 2 of them

3.4. Elements and Batteries

Az EuroProt+ protection family devices do not contain either a single-use battery or a rechargeable battery.