

Manual

Transformer Protection & control
EuroProt+/DTRV

E7-TR

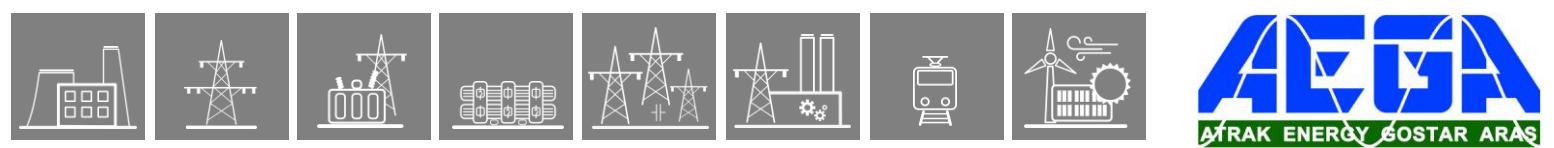

VERSION INFORMATION

NAME	DOCUMENT ID	VERSION	DATE
EuroProt+ DTRV type	PP-13-21886	1.0	2019-04-04
EuroProt+ Hardware description	PP-13-19958	2.0	2023-02-10
Definite time undervoltage protection function	PP-13-21403	1.1	2017-01-11
Definite time overvoltage protection function	PP-13-21400	1.2	2017-01-11
Automatic tap changer controller function (parallel transformers included)	PP-13-21171	2.3	2023-01-13
Circuit breaker wear monitoring	PP-13-21310	1.1	2016-09-06
Circuit Breaker control	PP-13-21877	2.0	2019-04-01
Disconnecter control	PP-13-20396	2.0	2019-04-01
Ethernet Links function	PP-13-21870	1.0	2019-02-19
Application of high-speed TRIP contacts	PP-13-21592	1.1	2017-10-02
Voltage transformer supervision and dead line detection	VERSION 1.1	1.1	2011-10-25
Current input function block setting guide	VERSION 1.1	1.0	2015-01-29
Voltage input function block setting guide	VERSION 1.0	1.0	2015-01-29
Line measurement Frequency measurement Voltage measurement Current measurement	PP-13-21168	2.3	2021-09-02
Disturbance recorder	PP-13-20368	3.0	2017-06-02
AIC current input function	PP-13-21392	1.0	2017-01-03
Remote I/O (RIO) server description	PP-13-22346	1.0	2021-06-02
Technical notes on EOB interoperability	-	1.0	2011-06-27
Maintenance guide	PP-13-226045	2.0	2022-11-18
RTD temperature input function	PP-13-21394	1.0	2017-01-03
Average and maximum measurement function	PP-11-20109	1.0	2013-09-27
Metering function	PP-13-22238	2.1	2022-10-19
Trip value recorder function	PP-13-20947	2.1	2020-12-10
Voltage measurement selection function	VERSION 1.0	1.0	2013-02-06
EP+ Installation manual	PP-06-22516	1.0	2022-03-09
transcoder unit for transformer tap changer	PP-13-22348	1.0	2021-06-02

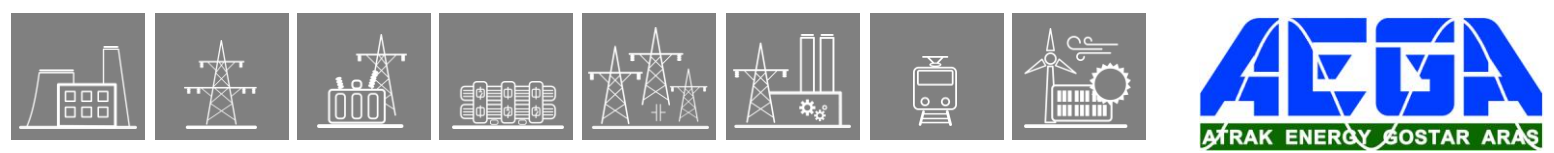
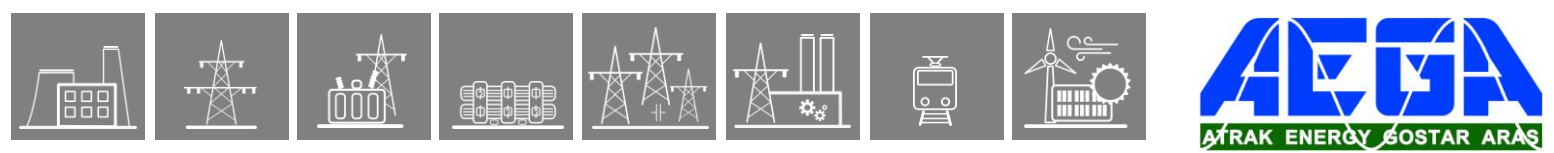
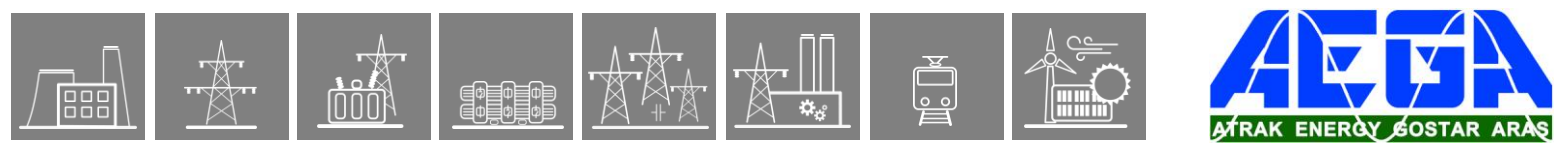

Table of Contents

1.	Introduction	5
1.1.	Application	5
1.1.1.	General features.....	5
1.2.	Pre-defined configuration variants	6
1.3.	Hardware configuration.....	7
1.3.1.	The applied hardware modules	8
1.3.2.	Meeting the device	9
1.3.3.	System design.....	10
1.3.4.	CPU and COM module	11
1.3.5.	Device housings	31
1.3.6.	Human-Machine Interface (HMI) module	33
1.3.7.	Current input module	40
1.3.8.	Voltage input module.....	45
1.3.9.	Binary input module.....	47
1.3.10.	Signaling module	50
1.3.11.	Tripping module.....	53
1.3.12.	RTD input module.....	74
1.3.13.	Analog input module (AI)	76
1.3.14.	Analog output module (ATO)	78
1.3.15.	Sensor input module.....	80
1.3.16.	INJ module.....	82
1.3.17.	Generator protection modules	83
1.3.18.	Power supply module	86
1.3.19.	Sampling synchronization module	90
1.3.20.	Mixed function modules	91
1.3.21.	General data.....	101
1.3.22.	Mechanical data.....	103
1.3.23.	Mounting methods.....	106
1.3.24.	Product availability (special and obsolete modules)	126
1.3.25.	Remote I/O (RIO) server description.....	131
1.3.26.	Technical notes on EOB interoperability.....	140
1.3.27.	EP+ Installation manual	143
1.3.28.	transcoder unit for transformer tap changer	151
2.	Function and I/O listing.....	158
3.	Software configuration	159
3.1.	Protection functions	159
3.1.1.	Definite time undervoltage protection function	160
3.1.2.	Definite time overvoltage protection function	168
3.1.3.	Automatic tap changer controller function (parallel transformers included).	177
3.2.	Control & supervision functions.....	201
3.2.1.	Circuit breaker wear monitoring function.....	201
3.2.2.	Circuit breaker control function block.....	206
3.2.3.	Disconnecter control function.....	212
3.2.4.	Ethernet Links function.....	219
3.2.5.	Voltage transformer supervision function.....	222
3.3.	Measuring functions.....	237



3.3.1.	Current input function	239
3.3.2.	AIC current input function.....	244
3.3.3.	Voltage input function	246
3.3.4.	Line and frequency measurement functions	254
3.3.5.	Average and maximum measurement function.....	264
3.3.6.	Metering	266
3.3.7.	Voltage selection function block.....	272
3.3.8.	Trip Value Recorder	274
3.3.9.	RTD temperature input function.....	277
3.4.	Disturbance recorder function	280
3.4.1.	Mode of recording.....	280
3.4.2.	Format of recording.....	281
3.4.3.	Downloading and evaluating the disturbance records	281
3.4.4.	Parameters of the disturbance recorder functions.....	281
3.4.5.	The input signals of the disturbance recorder functions	282
3.4.6.	The function blocks	282
3.4.7.	The recorded signals.....	282
3.5.	Event recorder.....	283
4.	Maintenance guide for EuroProt+ devices	284
4.1.	Foreword.....	284
4.2.	Safety precautions	284
4.2.1.	General guidelines for a scheduled maintenance of EP+ devices	285
4.3.	Power supply maintenance	286
4.4.	Elements and Batteries	288
5.	External connections.....	289



1. Introduction

The **DTRV** product type is a member of the **EuroProt+** product line, made by Protecta Co. Ltd. The **EuroProt+** complex protection in respect of hardware and software is a modular device. The modules are assembled and configured according to the requirements, and then the software determines the functions. This manual describes the **DTRV** product type.

1.1. Application

The **DTRV** products are designed for protection and control applications of power transformers and generators including generator-transformer blocks (these generator applications are handled independently).

The main application field of the **DTRV** type here is power transformers of any type with any vector group, whether it be two- or three-winding transformers, autotransformers at MV and/or HV voltage level.

The relays of this type support double breaker terminals such as breaker and a half or ring bus topology.

The main protection functions of the **DTRV** type include differential protection, overcurrent protections for both (or all three) sides, and voltage and frequency-based protections.

Additionally, the **DTRV** product type incorporates the control of tap changers / automatic voltage regulators by dedicated configuration variants.

Because of the implemented control, measuring and monitoring function, the IEDs can also be used as a bay control unit.

The **EuroCAP configuration tool**, which is available free of charge, offers a user-friendly and flexible application for protection, control and measurement functions to ensure that the IED-EP+ devices are fully customizable.

1.1.1. General features

- Native IEC 61850 IED with Edition 2 compatibility
- Scalable hardware to adapt to different applications
- 84 HP or 42HP wide rack size (height: 3U)
- The pre-defined factory configuration can be customized to the user's specification with the powerful EuroCAP tool
- Flexible protection and control functionality to meet special customer requirements
- Advanced HMI functionality via color touchscreen and embedded WEB server, extended measuring, control and monitoring functions
- User configurable LCD user screens, which can display SLDs (Single Line Diagrams) with switchgear position indication and control as well as measuring values and several types of controllable objects.
- Various protection setting groups available
- Enhanced breaker monitoring and control
- High capacity disturbance recorder (DRE) and event logging (data is stored in non-volatile memory):
 - DRE for up to 32 analogue and 64 digital signal channels.
 - Event recorder can store more than 10,000 events.
- Several mounting methods: Rack; Flush mounting; Semi-flush mounting; Wall mounting; Wall-mounting with terminals; Flush mounting with IP54 rated cover.
- Wide range of communication protocols:
 - Ethernet-based communication: IEC61850; IEC60870-5-104; DNP3.0 TCP; Modbus TCP
 - Serial communication: DNP3.0; IEC60870-5-101/103; MODBUS, SPA

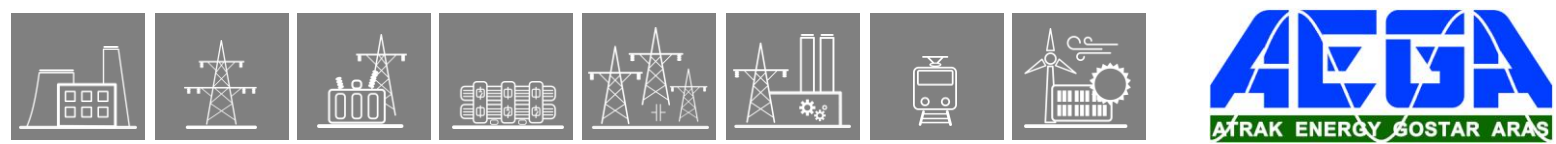

- The EuroProt+ family can handle several communication protocols simultaneously.
- Built-in self-monitoring to detect internal hardware or software errors
- Different time sources available: NTP server; Minute pulse; Legacy protocol master; IRIG-B000 or IRIG-B12X

1.2. Pre-defined configuration variants

The number and the functionality of the members of each product type is put together according to the application philosophy, keeping in mind the possible main usages. The available configurations of the DTRV type for transformers are listed in the table below.

VARIANT	MAIN APPLICATION
E0-Tr	Simplified protection for small transformers
E1-Tr	Two-winding transformer differential protection and control
E2-Tr	Two-winding transformer differential protection and control with voltage-based functions
E3-Tr	Two-winding transformer differential protection and control with voltage-based functions and automatic voltage regulator / tap changer controller
E4-Tr	Three-winding transformer differential protection and control
E5-Tr	Three-winding transformer differential protection and control with voltage-based functions
E6-Tr	Three-winding transformer differential protection and control with voltage-based functions and automatic voltage regulator / tap changer controller
E7-Tr	Automatic voltage regulator / tap changer controller

Table 1-1 The members of the DTRV type

Note that there are further members of the DTRV type, such as the E9, E10, E11 and E12 which are *generator protections* with several special functions, therefore they are handled separately from the ones listed here.

1.3. Hardware configuration

The minimum number of inputs and outputs are listed in the Table below.

Hardware configuration	ANSI	E7-TR
Mounting		Op.
Panel instrument case		
Current inputs (4th channel can be sensitive)		8
Voltage inputs		8
Digital inputs		12
Digital outputs		8
Fast trip outputs		-
Temperature monitoring (RTDs) *	38 / 49T	Op.

Table 3 The basic hardware configuration of the E7-TR configuration

The basic module arrangement of the E7-TR configuration is shown below.

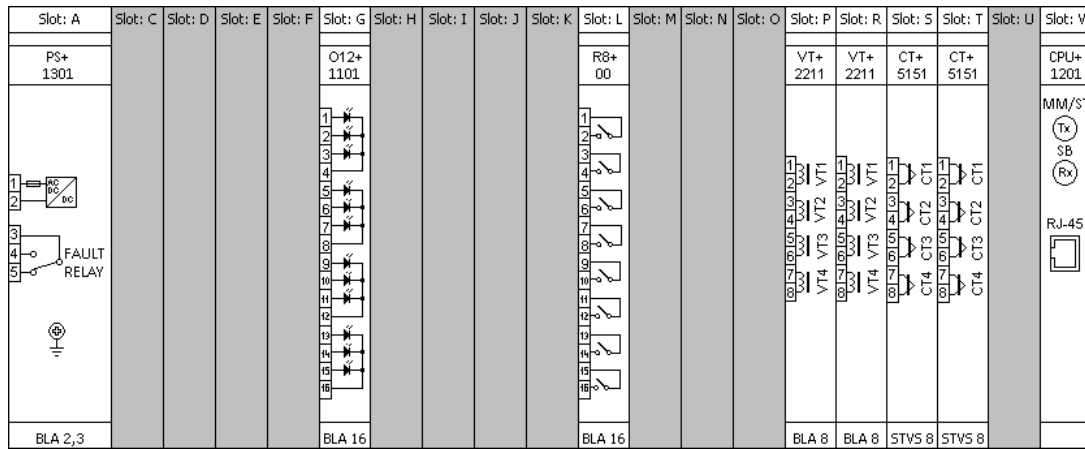

Figure 2 Basic module arrangement of the E7-TR configuration (84TE, rear view)

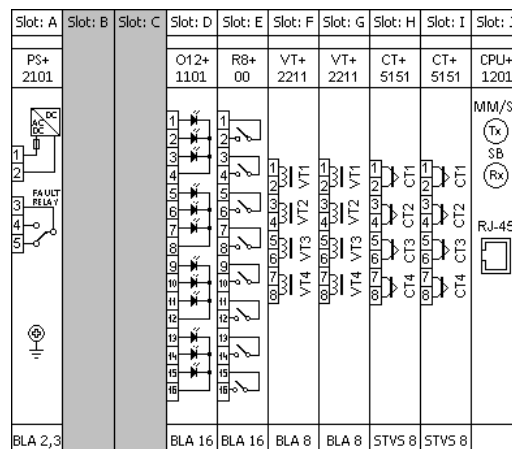

Figure 3 Basic module arrangement of the E7-TR configuration (42TE, rear view)

1.3.1. The applied hardware modules

The applied modules are listed in Table 4.

Module identifier	Explanation
PS+ 1301	Power supply unit (in 84TE)
PS+ 2101	Power supply unit (in 42TE)
O12+ 1101	Binary input module
R8+ 00	Signal relay output module
VT+ 2211	Analog voltage input module
CT + 5151	Analog current input module
CPU+ 1201	Processing and communication module

Table 4 The applied modules of the E7-TR configuration

The technical specification of the device and that of the modules are described in the document "**Hardware description**".

1.3.2. Meeting the device

The basic information for working with the **EuroProt+** devices are described in the document “**Quick start guide to the devices of the EuroProt+ product line**”.



*Figure 4 The 84 inch rack of **EuroProt+** family*



*Figure 5 The 42 inch rack of **EuroProt+** family*



*Figure 6 The double 42 inch rack of **EuroProt+** family*

1.3.3. System design

The EuroProt+ protection device family is a scalable hardware platform to adapt to different applications. Data exchange is performed via a 16-bit high-speed digital non-multiplexed parallel bus with the help of a backplane module.

Each module is identified by its location and there is no difference between module slots in terms of functionality. The only restriction is the position of the CPU module because it is limited to the “CPU” position. The built-in self-supervisory function minimizes the risk of device malfunctions.

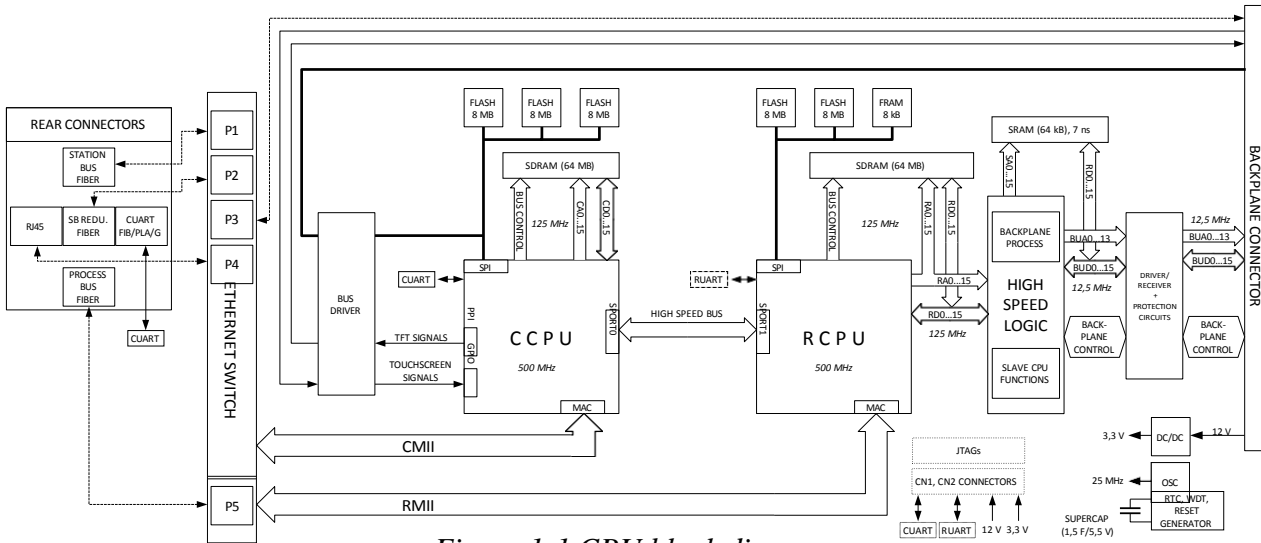
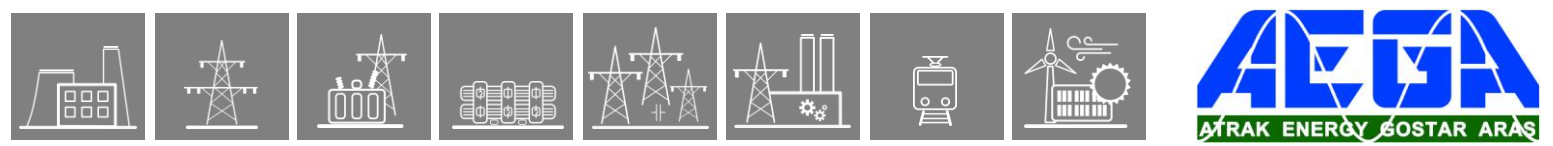

Figure 1-1 CPU block diagram

The backplane board itself is a passive board but it provides a 16-bit bus, power supply distribution, a two-wire interface (TWI) supporting module inventory management and module identification. It is designed to meet the requirements for high-speed digital buses and to comply with electromagnetic emission standards.



1.3.4. CPU and COM module

1.3.4.1. CPU+ module

The CPU module contains all the protection, control and communication functions of the EuroProt+ device. Dual 500 MHz high-performance Analog Devices Blackfin processors separate relay functions (RDSP) from communication and HMI functions (CDSP). Reliable communication between processors is performed via high-speed synchronous serial internal bus (SPORT).

Each processor has its own operative memory such as SDRAM and flash memories for configuration, parameter and firmware storage. Both firmware are stored in a dedicated flash memory independent from the disturbance recorder and event storage.

The CDSP's operating system (uClinux) utilizes a robust JFFS flash file system, which enables fail-safe operation and the storage of disturbance record files, configuration and parameters.

The RDSP core runs at 500 MHz and its external bus speed is 125 MHz. The backplane data speed is limited to approx. 20 MHz, which is more than enough for module data throughput. An additional logic element (CPLD and SRAM) is used as a bridge between the RDSP and the backplane. The CPLD collects analogue samples from CT/VT modules and also controls signaling outputs and inputs.

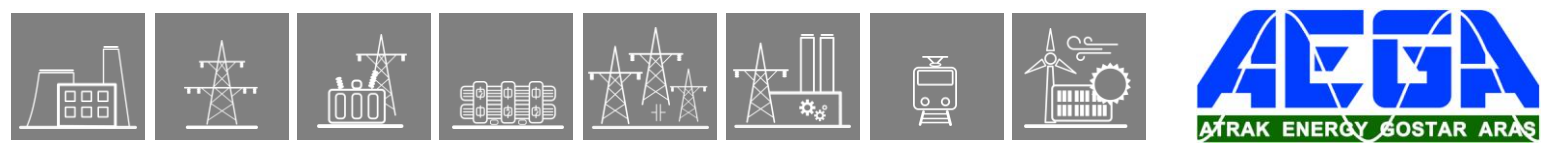

1.3.4.1.1. Fast start-up

After power-up the RDSP processor starts up with the previously saved configuration and parameters. Generally, the power-up procedure for the RDSP and relay functions takes only a few seconds. That is to say, it is ready to trip within this time. CDSP's start-up procedure is longer because its operating system needs time to build its file system, initializing user applications such as HMI functions and the IEC61850 software stack.

1.3.4.1.2. HMI and communication tasks

- Embedded WEB-server:
 - Firmware upgrade possibility
 - Modification of user parameters
 - Events list and disturbance records
 - Password management
 - Online data measurement
 - Commands
 - Administrative tasks
- Front panel TFT display handling: the interactive menu set is available through the TFT and the touchscreen interface
- User keys: capacitive touch keys on front panel
- The built-in 5-port Ethernet switch allows EuroProt+ to connect to IP/Ethernet-based networks. The following Ethernet ports are available:
 - Station bus (100Base-FX Ethernet) SBW
 - Redundant station bus (100Base-FX Ethernet) SBR
 - Process bus (100Base-FX Ethernet)
 - EOB2 (Ethernet Over Board) or RJ-45 Ethernet user interface on front panel
 - Optional 10/100Base-T port via RJ-45 connector
- PRP/HSR seamless redundancy for Ethernet networking (100Base-FX Ethernet)
- Other communication:
 - RS422/RS485 interfaces (galvanic interface to support legacy or other serial protocols, ASIF)
 - Plastic or glass fiber interfaces to support legacy protocols, ASIF
 - Proprietary process bus communication controller on COM+ module
 - Telecommunication interfaces: G.703, IEEE C37.94

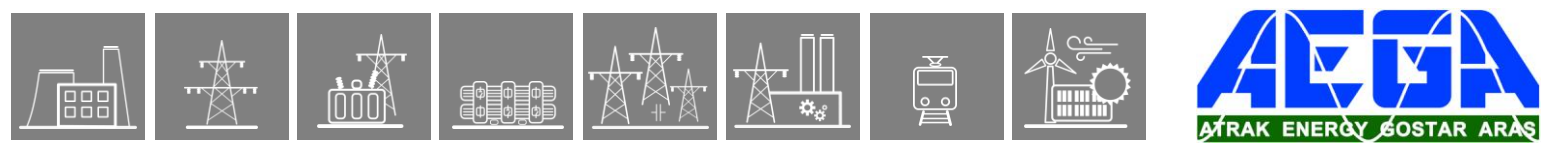

CPU VERSION	PRIMARY STATION BUS SBW	SECONDARY (REDUNDANT) STATION BUS SBR	LEGACY PORT/PROTOCOL	PROCESS BUS (FIBER) PB	SERVICE PORT ON FRONT PANEL EOB/ RJ45
CPU+/0007	-	-	-	-	+
CPU+/0091	-	-	-	+ SM SH	+
CPU+/0201*	-	+ RJ45	-	-	+
CPU+/0211*	-	+ RJ45	-	+ MM	+
CPU+/0281*	-	+ RJ45	-	+ SM LH	+
CPU+/0291*	-	+ RJ45	-	+ SM SH	+
CPU+/0301	-	-	+ POF	-	+
CPU+/0401	-	-	+ GS	-	+
CPU+/0501*	-	-	+ Galv. RS485/422	-	+
CPU+/1001	+ MM	-	-	-	+
CPU+/1004	+ MM	-	-	-	+
CPU+/1011	+ MM	-	-	+ MM	+
CPU+/1091	+ MM	-	-	+ SM SH	+
CPU+/1101*	+ MM	+ MM	-	-	+
CPU+/1111	+ MM	+ MM	-	+ MM	+
CPU+/1181	+ MM	+ MM	-	+ SM LH	+
CPU+/1191	+ MM	+ MM	-	+ SM SH	+
CPU+/1201*	+ MM	+ RJ45	-	-	+
CPU+/1202	+ MM	+ RJ45	-	-	+
CPU+/1211	+ MM	+ RJ45	-	+ MM	+
CPU+/1281	+ MM	+ RJ45	-	+ SM LH	+
CPU+/1291*	+ MM	+ RJ45	-	+ SM SH	+
CPU+/1292	+ MM	+ RJ45	-	+ SM SH	+
CPU+/1301	+ MM	-	+ POF	-	+
CPU+/1311	+ MM	-	+ POF	+ MM	+
CPU+/1331	+ MM	-	+ double POF	-	+
CPU+/1381	+ MM	-	+ POF	+ SM LH	+
CPU+/1391	+ MM	-	+ POF	+ SM SH	+
CPU+/1401	+ MM	-	+ GS	-	+
CPU+/1411	+ MM	-	+ GS	+ MM	+
CPU+/1481	+ MM	-	+ GS	+ SM LH	+
CPU+/1491	+ MM	-	+ GS	+ SM SH	+
CPU+/1501	+ MM	-	+ Galv. RS485/422	-	+
CPU+/1511	+ MM	-	+ Galv. RS485/422	+ MM	+

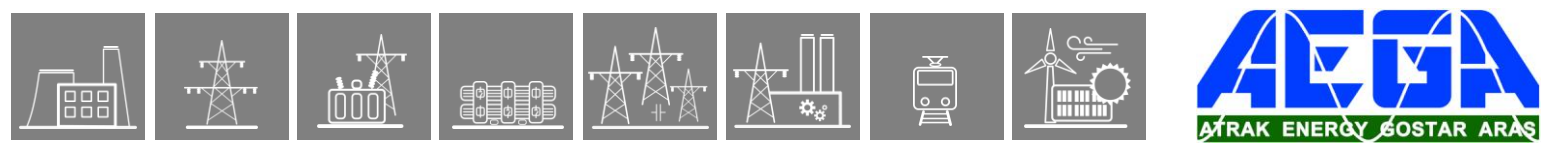

CPU VERSION	PRIMARY STATION BUS (FIBER) SBW	SECONDARY (REDUNDANT) STATION BUS SBR	LEGACY PORT/PROTOCOL	PROCESS BUS (FIBER) PB	SERVICE PORT ON FRONT PANEL EOB/ RJ45
CPU+/1581	+ MM	-	+ Galv. RS485/422	+ SM LH	+
CPU+/1611	+ MM	-	+ Galvanic sync	+ MM	+
CPU+/1681	+ MM	-	+ Galvanic sync	+ SM LH	+
CPU+/6001	+ MM/LC	-	-	-	+
CPU+/6004	+ MM/LC	-	-	-	+
CPU+/6093	+ MM/LC	-	-	+ SM SH	+
CPU+/6094	+ MM/LC	-	-	+ SM SH	+
CPU+/6601*	+ MM/LC	+ MM/LC	-	-	+
CPU+/9201	+ SM SH	+ RJ45	-	-	+
CPU+/9291	+ SM SH	+ RJ45	-	+ SM SH	+
CPU+/9501	+ SM SH	-	+ Galv. RS485/422	-	+
CPU+/9901	+ SM SH	+ SM SH	-	-	+
CPU+/A001*	+ MM/LC PRP/HSR	-	-	-	+
CPU+/A004	+ MM/LC PRP/HSR	-	-	-	+
CPU+/A011	+ MM/LC PRP/HSR	-	-	+ MM	+
CPU+/A081	+ MM/LC PRP/HSR	-	-	+ SM LH	+
CPU+/A091	+ MM/LC PRP/HSR	-	-	+ SM SH	+
CPU+/A094	+ MM/LC PRP/HSR	-	-	+ SM SH	+

*Note: the modules can be equipped with a different handle (narrower and made of aluminum, instead of the standard plastic), if the other modules of the device are equipped with top-screw terminals (see Chapter 20.2). In these cases, a "T" letter appears on the label of the module (e.g. CPU+/1201T), but all other properties remain the same.

For legacy CPU cards (e.g. CPU+0001, ...) see [Product availability](#) chapter.

PRP/HSR option: A and F types can be ordered with PRP/HSR communication as sw option **Legend for CPU version table:**

MM: Multimode with ST connector	GS: Glass with ST connector
MM/LC: Multimode with LC connector	SFP: Small Form-factor Pluggable connector
SM: Single mode with FC/PC connector	SB: Station Bus
LH: Long Haul with FC/PC connector	SBW: Station Bus Working
SH: Short Haul with FC/PC connector	SBR: Station Bus Redundant
POF: Plastic Optical Fiber with 1 mm fiber connector	PB: Proprietary Process Bus

CPU+ 0007	CPU+ 0091	CPU+ 0201	CPU+ 0211	CPU+ 0281	CPU+ 0291	CPU+ 0301	CPU+ 0401	CPU+ 0501	CPU+ 1001	CPU+ 1004
									MM/ST	MM/ST
									Tx SB Rx	Tx SB Rx
		RJ-45	RJ-45	RJ-45	RJ-45	POF Tx Rx	GS/ST Tx ASIF Rx	Tx+ Tx- GND Rx- Rx+		
	SM SH FCPC Tx PB Rx		MM/ST Tx PB Rx	SM LH FCPC Tx PB Rx	SM SH FCPC Tx PB Rx			1 2 3 4 5		
CPU+ 1011	CPU+ 1091	CPU+ 1101	CPU+ 1111	CPU+ 1181	CPU+ 1191	CPU+ 1201	CPU+ 1202	CPU+ 1211	CPU+ 1281	CPU+ 1291
MM/ST	MM/ST	MM/ST	MM/ST	MM/ST	MM/ST	MM/ST	MM/ST	MM/ST	MM/ST	MM/ST
Tx SB Rx	Tx SB Rx	Tx SBW Rx	Tx SBW Rx	Tx SBW Rx	Tx SBW Rx	Tx SB Rx	Tx SBW Rx	Tx SB Rx	Tx SB Rx	Tx SB Rx
		MM/ST	MM/ST	MM/ST	MM/ST	RJ-45	RJ-45	RJ-45	RJ-45	RJ-45
MM/ST	SM SH FCPC	Tx SBR Rx	Tx SBR Rx	Tx SBR Rx	Tx SBR Rx				SM LH FCPC	SM SH FCPC
Tx PB Rx	Tx PB Rx		MM/ST Tx PB Rx	SM LH FCPC Tx PB Rx	SM SH FCPC Tx PB Rx			MM/ST Tx PB Rx	Tx PB Rx	Tx PB Rx
CPU+ 1292	CPU+ 1301	CPU+ 1311	CPU+ 1331	CPU+ 1381	CPU+ 1391	CPU+ 1401	CPU+ 1411	CPU+ 1481	CPU+ 1491	CPU+ 1501
MM/ST	MM/ST	MM/ST	MM/ST	MM/ST	MM/ST	MM/ST	MM/ST	MM/ST	MM/ST	MM/ST
Tx SBW Rx	Tx SB Rx	Tx SB Rx	Tx SB Rx	Tx SB Rx	Tx SB Rx	Tx SB Rx	Tx SB Rx	Tx SB Rx	Tx SB Rx	Tx SB Rx
RJ-45	POF	POF	POF1	POF	POF	GS/ST	GS/ST	GS/ST	GS/ST	Tx+ Tx- GND Rx- Rx+
	Tx Rx	Tx Rx	Tx Rx	Tx Rx	Tx Rx	Tx ASIF Rx	Tx ASIF Rx	Tx ASIF Rx	Tx ASIF Rx	1 2 3 4 5
SM SH FCPC		MM/ST	POF2	SM LH FCPC	SM SH FCPC		MM/ST	SM LH FCPC	SM SH FCPC	
Tx PB Rx		Tx PB Rx	Tx Rx	Tx PB Rx	Tx PB Rx		Tx PB Rx	Tx PB Rx	Tx PB Rx	

CPU+ 1511	CPU+ 1581	CPU+ 1611	CPU+ 1681	CPU+ 6001	CPU+ 6004	CPU+ 6093	CPU+ 6094	CPU+ 6601	CPU+ 9201	CPU+ 9291
MM/ST	MM/ST	MM/ST	MM/ST	MM/LC	MM/LC	MM/LC	MM/LC	MM/LC	SM SH FCPC	SM SH FCPC
Tx	Tx	Tx	Tx	Rx	Rx	Rx	Rx	Rx	Tx	Tx
SB	SB	SB	SB						SB	SB
Rx	Rx	Rx	Rx						Rx	Rx
Tx+ 1	Tx+ 1	-	-					MM/LC		
Tx- 2	Tx- 2	-	-					Rx	RJ-45	RJ-45
GND 3	GND 3	GND 3	GND 3							
Rx- 4	Rx- 4	Sy- 4	Sy- 4							
Rx+ 5	Rx+ 5	Sy+ 5	Sy+ 5							
MM/ST	SM LH FCPC	MM/ST	SM LH FCPC			SM SH FCPC	SM SH FCPC			SM SH FCPC
Tx	Tx	Tx	Tx			Tx	Tx			Tx
PB	PB	PB	PB			PB	PB			PB
Rx	Rx	Rx	Rx			Rx	Rx			Rx
CPU+ 9501	CPU+ 9901	CPU+ A001	CPU+ A004	CPU+ A011	CPU+ A081	CPU+ A091	CPU+ A094			
SM SH FCPC	SM SH FCPC	PRP/HSR MM/LC	PRP/HSR MM/LC	PRP/HSR MM/LC	PRP/HSR MM/LC	PRP/HSR MM/LC	PRP/HSR MM/LC			
Tx	Tx	Rx	Rx	Rx	Rx	Rx	Rx			
SB	PB	LAN A	LAN A	LAN A	LAN A	LAN A	LAN A			
Rx	Rx	Rx	Rx	Rx	Rx	Rx	Rx			
Tx+ 1	SM SH FCPC	LAN B	LAN B	LAN B	LAN B	LAN B	LAN B			
Tx- 2	Tx	LAN C	LAN C	LAN C	LAN C	LAN C	LAN C			
GND 3	PB	LAN D	LAN D	LAN D	LAN D	LAN D	LAN D			
Rx- 4	Rx	LAN E	LAN E	LAN E	LAN E	LAN E	LAN E			
Rx+ 5	Rx	LAN F	LAN F	LAN F	LAN F	LAN F	LAN F			
		A B I	A B I	A B I	A B I	A B I	A B I			
		LINK/ACT	LINK/ACT	LINK/ACT	LINK/ACT	LINK/ACT	LINK/ACT			
				MM/ST	SM LH FCPC	SM SH FCPC	SM SH FCPC			
				Tx	Tx	Tx	Tx			
				PB	PB	PB	PB			
				Rx	Rx	Rx	Rx			

Figure 2-1 CPU versions

Interface types:

- 100Base-FX Ethernet:
 - MM/ST 1300 nm, 50/62.5/125 μ m connector, (up to 2 km) fiber
 - SM/FC 1550 nm, 9/125 μ m connector, (LH: long haul, up to 120 km)
 - SM/FC 1550 nm, 9/125 μ m connector, (SH: short haul, up to 50 km)
 - MM/LC 1300 nm, 50/62.5/125 μ m connector, (up to 2 km) fiber
- 10/100 Base-TX Ethernet: RJ-45-8/8
- Service port on HMI:
 - 10/100 Base-T Ethernet: RJ-45-8/8
 - EOB2 interface: attachable to the front panel by a proprietary magnetic connector; the connector box ends in a RJ-45 8/8 plug. It is 10Base-T full duplex interface, and it enables 10/100Base TX communication with service computers.
- ASIF: Asynchronous Serial Interface
 - plastic optical fiber (ASIF-POF)
 - glass with ST connector (ASIF-GS)
 - galvanic RS485/422 (ASIF-G)

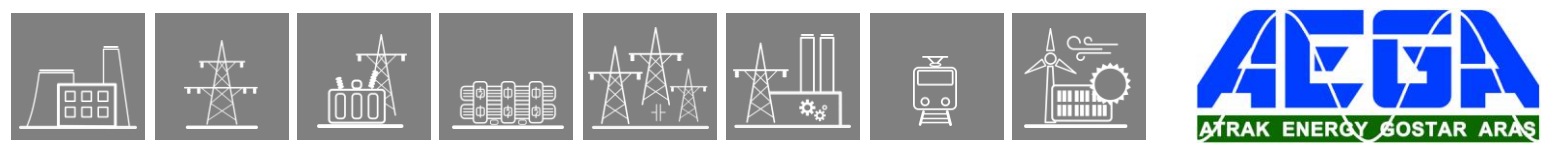

1.3.4.2. COM modules

The COM+ modules are responsible for special communication tasks, these are the following:

- binary signal transmission
- line differential protection communication via Ethernet or telecommunication networks
- busbar differential protection communication
- multi-port Ethernet switch using MODBUS/TCP protocol for Remote I/O (RIO) servers

1.3.4.2.1. COM modules for binary signal transmission

MODULE TYPE	INTERFACE TYPE	NUMBER OF INTERFACES	UNIT WIDTH	APPLICATION
COM+/1801*	MM/ST 1300 nm, 50/62.5/125 μm and SM/FC 1550 nm, 9/125 μm connector, 100Base-FX Ethernet	2	4 HP	Line differential protection, binary signal transmission up to 2 km and up to 120 km
COM+/1901*	MM/ST 1300 nm, 50/62.5/125 μm and SM/FC 1550 nm, 9/125 μm connector, 100Base-FX Ethernet	2	4 HP	Line differential protection, binary signal transmission up to 2 km and up to 50 km
COM+/8882	SM/FC 1550 nm, 9/125 μm connector, 100Base-FX Ethernet	3	4 HP	3 direction binary signal transmission up to 120 km
COM+/9902	SM/FC 1550 nm, 9/125 μm connector, 100Base-FX Ethernet	2	4 HP	2 direction binary signal transmission up to 50 km
COM+/9992	SM/FC 1550 nm, 9/125 μm connector, 100Base-FX Ethernet	3	4 HP	3 direction binary signal transmission up to 50 km

*Note: the modules can be equipped with a different handle (narrower and made of aluminum, instead of the standard plastic), if the other modules of the device are equipped with top-screw terminals (see Chapter 20.2). In these cases, a "T" letter appears on the label of the module (e.g. **COM+/1801T**), but all other properties remain the same

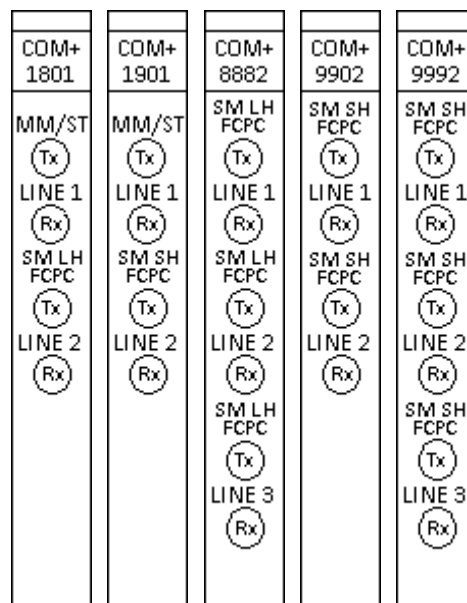

Figure 2-2 COM modules for binary signal transmission

1.3.4.2.2. COM modules for line differential communication

MODULE TYPE	INTERFACE TYPE	NUMBER OF INTERFACES	UNIT WIDTH	APPLICATION
COM+/0091	G703.1 (64 kbit/s)	1	4 HP	Line differential protection via telecom network
COM+/1101	MM/ST 1300 nm, 50/62.5/125 μm connector, 100Base-FX Ethernet	2	4 HP	3 terminals / redundant line differential protection up to 2 km
COM+/1801*	MM/ST 1300 nm, 50/62.5/125 μm and SM/FC 1550 nm, 9/125 μm connector, 100Base-FX Ethernet	2	4 HP	3 terminals / redundant line differential protection up to 2 km and up to 120 km
COM+/1901*	MM/ST 1300 nm, 50/62.5/125 μm and SM/FC 1550 nm, 9/125 μm connector, 100Base-FX Ethernet	2	4 HP	3 terminals / redundant line differential protection up to 2 km and up to 50 km
COM+/8801	SM/FC 1550 nm, 9/125 μm connector, 100Base-FX Ethernet	2	4 HP	3 terminals / redundant line differential protection up to 120 km
COM+/9901	SM/FC 1550 nm, 9/125 μm connector, 100Base-FX Ethernet	2	4 HP	3 terminals / redundant line differential protection up to 50 km

*Note: the modules can be equipped with a different handle (narrower and made of aluminum, instead of the standard plastic), if the other modules of the device are equipped with top-screw terminals (see Chapter 20.2). In these cases, a "T" letter appears on the label of the module (e.g. **COM+/1801T**), but all other properties remain the same

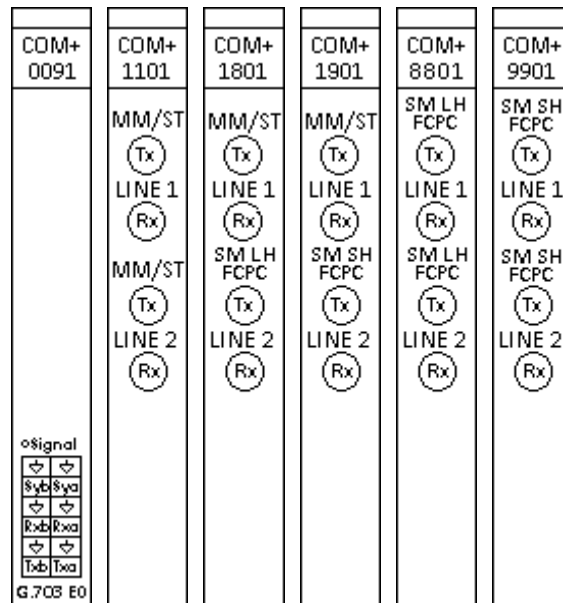

Figure 2-3 COM modules for line differential applications

1.3.4.2.3. COM modules for busbar differential protection communication

MODULE TYPE	INTERFACE TYPE	NUMBER OF INTERFACES	UNIT WIDTH	APPLICATION
COM+/1111	MM/ST 1300 nm, 50/62.5/125 µm connector, 100Base-FX Ethernet	3	4 HP	Busbar protection for 3 bay units up to 2 km
COM+/1111D	MM/ST 1300 nm, 50/62.5/125 µm connector, 100Base-FX Ethernet	3	4 HP	Busbar protection for 3x2 bay units (dual) up to 2 km

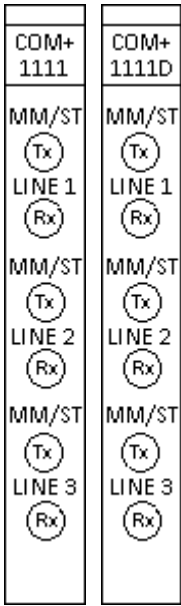

Figure 2-4 COM modules for busbar differential protections

1.3.4.2.4. COM modules for Remote I/O (RIO) servers

MODULE TYPE	INTERFACE TYPE	NUMBER OF INTERFACES	UNIT WIDTH	APPLICATION
COM+/1202*	MM/LC 1300 nm, 50/62.5/125 μm connector, 100Base-FX Ethernet	2	8 HP	2-port Ethernet switch for MODBUS via RIO
COM+/1324*	MM/LC 1300 nm, 50/62.5/125 μm connector, 100Base-FX Ethernet	4	8 HP	4-port Ethernet switch for MODBUS via RIO
COM+/1335	MM/LC 1300 nm, 50/62.5/125 μm connector, 100Base-FX Ethernet	5	8 HP	5-port Ethernet switch for MODBUS via RIO
COM+/6603	MM/LC 1300 nm, 50/62.5/125 μm connector, 100Base-FX Ethernet	2	4 HP	2-port Ethernet switch for MODBUS via RIO
COM+/6663	MM/LC 1300 nm, 50/62.5/125 μm connector, 100Base-FX Ethernet	3	4 HP	3-port Ethernet switch for MODBUS via RIO

***Obsolete module. These modules are not recommended for new designs!**

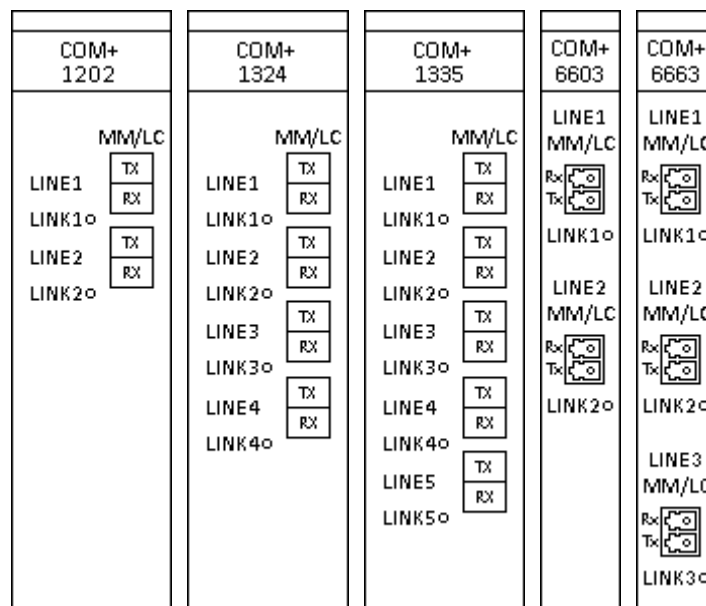

Figure 2-5 COM modules for RIO servers

1.3.4.3. Communication interface characteristics

1.3.4.3.1. Ethernet multi-mode transmitter and receiver

1.3.4.3.1.1. MM/ST connector

Up to approximately 2 km.

Transmitter

PARAMETER	SYMBOL	MIN.	TYP.	MAX.	UNIT
OPTICAL OUTPUT POWER 62.5/125 μm , NA = 0.275 FIBER	P_O	BOL*: -19 EOL*: -20	-	-14	dBm avg.
OUTPUT OPTICAL POWER 50/125 μm , NA = 0.20 FIBER	P_O	BOL*: -22.5 EOL*: -23.5	-	-14	dBm avg.
OPTICAL EXTINCTION RATIO	ER	-	-	10 -10	% dB
CENTER WAVELENGTH	λ_C	1270	1308	1380	nm

* BOL: Beginning of life, EOL: End of life

Note: according to field experiences, the 62.5/125 μm cabling is recommended for applications where the center wavelength is 1300/1310 nm.

Receiver sensitivity is measured with $2^{23} - 1$ PRBS pattern within BER = 2.5×10^{-10}

PARAMETER	SYMBOL	MIN.	TYP.	MAX.	UNIT
SIGNAL DETECT - ASSERTED	P_A	$P_D + 1.5 \text{ dB}$	-	-33	dBm avg.
SIGNAL DETECT - DEASSERTED	P_D	-45	-	-	dBm avg.
SIGNAL DETECT - HYSTERESIS	$P_A - P_D$	1.5	-	-	dB
SIGNAL DETECT ASSERT TIME (OFF TO ON)	AS_Max	0	2	100	μs
SIGNAL DETECT DEASSERT TIME (ON TO OFF)	ANS_Max	0	8	350	μs

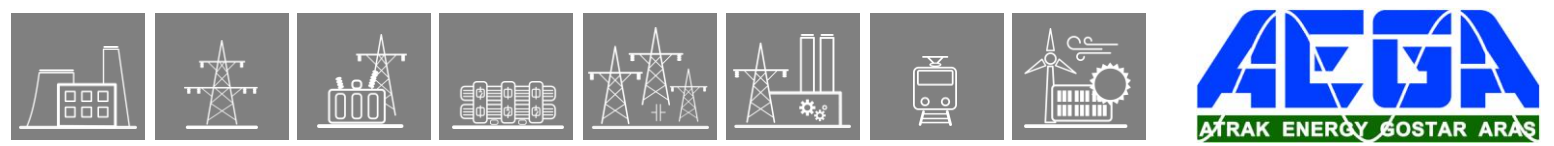

1.3.4.3.1.2. MM/LC connector

Up to approximately 2 km.

Transmitter

PARAMETER	SYMBOL	MIN.	TYP.	MAX.	UNIT
OPTICAL OUTPUT POWER** 62.5/125 μm , NA = 0.275 FIBER	P_O	BOL*: -19 EOL*: -20	-15.7	-14	dBm avg.
OUTPUT OPTICAL POWER 50/125 μm , NA = 0.20 FIBER	P_O	BOL*: -22.5 EOL*: -23.5	-	-14	dBm avg.
OPTICAL EXTINCTION RATIO	ER	-	0.002 -47	0.2 -27	% dB
CENTER WAVELENGTH	λ_C	1270	1308	1380	nm

* BOL: Beginning of life, EOL: End of life

Note: according to field experiences, the 62.5/125 μm cabling is recommended for applications where the center wavelength is 1300/1310 nm.

Receiver sensitivity is measured with $2^{23} - 1$ PRBS pattern within BER = 2.5×10^{-10}

PARAMETER	SYMBOL	MIN.	TYP.	MAX.	UNIT
SIGNAL DETECT - ASSERTED	P_A	$P_D + 1.5 \text{ dB}$	-	-33	dBm avg.
SIGNAL DETECT - DEASSERTED	P_D	-45	-	-	dBm avg.
SIGNAL DETECT - HYSTERESIS	$P_A - P_D$	1.5	-	-	dB
SIGNAL DETECT ASSERT TIME (OFF TO ON)	AS_Max	0	2	100	μs
SIGNAL DETECT DEASSERT TIME (ON TO OFF)	ANS_Max	0	5	100	μs

1.3.4.3.2. Ethernet single mode transmitter and receiver

1.3.4.3.2.1. Long haul single mode transceiver

Up to approximately 120 km, with max. 32 dB link attenuation.

Transmitter

PARAMETER	SYMBOL	MIN.	TYP.	MAX.	UNIT
OPTICAL OUTPUT POWER	P_O	-6	-	0	dBm avg.
OPTICAL EXTINCTION RATIO	ER	8.3	-	-	dB
CENTER WAVELENGTH	λ_C	1490	1550	1610	nm

Receiver sensitivity is measured with $2^{23} - 1$ PRBS pattern within $BER = 2.5 \times 10^{-10}$

PARAMETER	SYMBOL	MIN.	TYP.	MAX.	UNIT
OPTICAL INPUT SENSITIVITY	P_{IN}	-	-38	-35	dBm avg.
SATURATION	P_{SAT}	-3	0	-	dBm
CENTER WAVELENGTH	λ_C	1100	-	1600	nm
SIGNAL DETECT - ASSERTED	P_A	-	-	-35	dBm avg.
SIGNAL DETECT - DEASSERTED	P_D	-45	-	-	dBm avg.
HYSTERESIS	P_{HYS}	-	3	-	dB

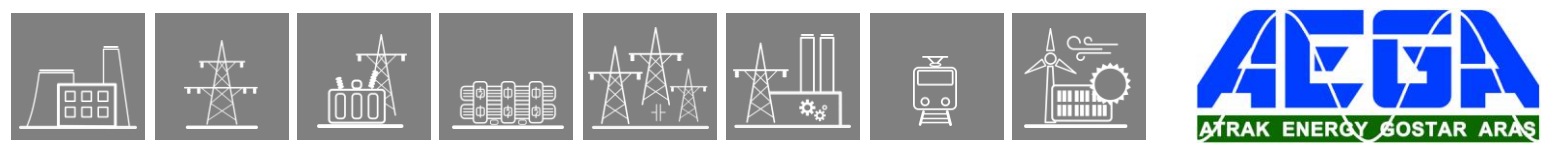

1.3.4.3.2.2. Short haul single mode transceiver

Up to approximately 50 km, with max. 27 dB link attenuation.

Transmitter

PARAMETER	SYMBOL	MIN.	TYP.	MAX.	UNIT
OPTICAL OUTPUT POWER	P_O	-12	-	-6	dBm avg.
OPTICAL EXTINCTION RATIO	ER	8.3	-	-	dB
CENTER WAVELENGTH	λ_C	1490	1550	1610	nm

Receiver sensitivity is measured with $2^{23} - 1$ PRBS pattern within $BER = 2.5 \times 10^{-10}$

PARAMETER	SYMBOL	MIN.	TYP.	MAX.	UNIT
OPTICAL INPUT SENSITIVITY	P_{IN}	-	-38	-35	dBm avg.
SATURATION	P_{SAT}	-3	0	-	dBm
CENTER WAVELENGTH	λ	1100	-	1600	nm
SIGNAL DETECT - ASSERTED	P_A	-	-	-35	dBm avg.
SIGNAL DETECT - DEASSERTED	P_D	-45	-	-	dBm avg.
HYSTERESIS	P_{HYS}	-	3	-	dB

1.3.4.3.3. ASIF-O transmitter and receiver

1.3.4.3.3.1. ASIF-O POF

Transmitter

PARAMETER	SYMBOL	MIN.	TYP.	MAX.	UNIT	JUMPER SETTINGS
TRANSMITTER OUTPUT OPTICAL POWER	P_T	-15.3	-	-9	dBm	JP1 2-3
		-23.3	-	-17		JP1 1-2
PEAK EMISSION WAVELENGTH	λ_{PK}	-	660	-	nm	
EFFECTIVE DIAMETER	D	-	1	-	mm	
NUMERICAL APERTURE	NA	-	0.5	-		

Receiver

PARAMETER	SYMBOL	MIN.	TYP.	MAX.	UNIT
INPUT OPTICAL POWER LEVEL LOGIC 0	$P_{R(L)}$	-39	-	-13.7	dBm
INPUT OPTICAL POWER LEVEL LOGIC 1	$P_{R(H)}$	-	-	-53	dBm
EFFECTIVE DIAMETER	D	-	1	-	mm
NUMERICAL APERTURE	NA	-	0.5	-	

These characteristics are valid for both POF interfaces in CPU+1331 module.

1.3.4.3.3.2. ASIF-O GLASS

Transmitter (Output measured out of 1 meter of cable)

PARAMETER	SYMBOL	MIN.	TYP.	MAX.	UNIT	JUMPER SETTINGS
50/125 μm FIBER CABLE NA = 0.2	P_o	-19.4	-16.4	-14.4	dBm peak	JP1 2-3
		-28.9	-25.9	-23.9		JP1 1-2
62.5/125 μm FIBER CABLE NA = 0.275	P_o	-15.6	-12.6	-10.6	dBm peak	JP1 2-3
		-22.9	-19.9	-17.9		JP1 1-2

Receiver

PARAMETER	SYMBOL	MIN.	TYP.	MAX.	UNIT
PEAK OPTICAL INPUT POWER LOGIC LEVEL HIGH ($\lambda_P = 820 \text{ nm}$)	P_{RH}	-25.4	-	-9.2	dBm peak
PEAK OPTICAL INPUT POWER LOGIC LEVEL LOW	P_{RL}	-	-	-40	dBm peak

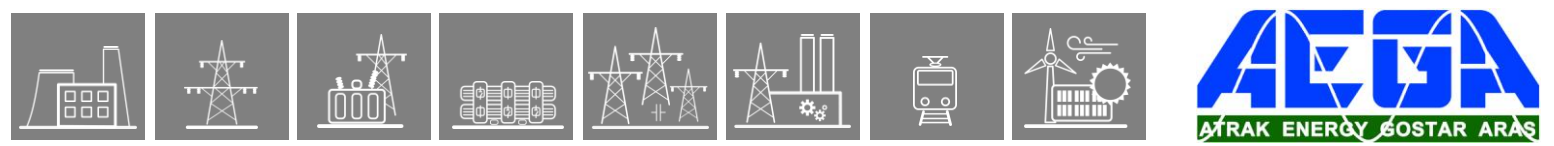

1.3.4.3.4. ASIF-G transmitter and receiver

The RS422/RS485 interfaces of our CPU+1501, CPU+1511, CPU+1581, CPU+9501 modules provide galvanic interface to support legacy or other serial protocols. For more details see our RS485/422 application note, available on our homepage.

Transmitter

PARAMETER	SYMBOL	MIN.	TYP.	MAX.	UNIT
DIFFERENTIAL OUTPUT VOLTAGE (LOADED, $R_L = 100 \Omega$, RS422)	V_{OD2}	2	-	3.6	V
DIFFERENTIAL OUTPUT VOLTAGE (LOADED, $R_L = 54 \Omega$, RS485)	V_{OD2}	1.5	-	3.6	V

Receiver

PARAMETER	SYMBOL	MIN.	TYP.	MAX.	UNIT
DIFFERENTIAL INPUT THRESHOLD VOLTAGE	V_{TH}	-200	-125	-30	mV
INPUT VOLTAGE HYSTERESIS	V_{HYS}	-	15	-	mV
LINE INPUT RESISTANCE	R_{IN}	96	-	-	k Ω

1.3.4.3.5. G.703 64 kbit/s co-directional interface (E0)

The EuroProt+ device also supports line differential communication via telecom networks using

- 64 kbit/s co-directional interface type through COM+0091. This type of communication is performed via 2 x 2 wire isolated galvanic type interface. The protection device is connected to a multiplexer or gateway which is responsible for protocol/speed conversion.

- Connector type: Weidmüller: Receptacle: S2L 3.50/12/90 F
Plug: B2L 3.50/12/180 F
- Impedance: 120 Ω
- Cable length: 50 m
- Interface type: G.703.1 64 kbit/s (E0) co-directional, selectable grounding, with optional external clock input

For further information about the cable assembly of this type of interface please see our G.703 E0 cable assembly guide.

Receiver

PARAMETER	VALUE
LOSS OF SIGNAL ALARM LEVEL	± 1.5 dB difference between alarm-on and alarm-off
DYNAMIC RANGE	10 dB maximum cable loss range

Transmitter

PARAMETER	VALUE
PAIR FOR EACH DIRECTION	± 1.5 dB difference between alarm-on and alarm-off
TEST LOAD IMPEDANCE	10 dB maximum cable loss range
NOMINAL PEAK VOLTAGE OF A “MARK” (PULSE)	One symmetric pair
PEAK VOLTAGE OF A “SPACE” (NO PULSE)	120 Ω resistive
NOMINAL PULSE WIDTH	1.0 V
RATIO OF THE AMPLITUDES OF POSITIVE AND NEGATIVE	0 V ± 0.10 V
PULSES AT THE CENTRE OF THE PULSES INTERVAL	3.9 ms
RATIO OF THE WIDTHS OF POSITIVE AND NEGATIVE PULSES	0.95 to 1.05
AT THE NOMINAL HALF AMPLITUDE	0.95 to 1.05
MAXIMUM PEAK-TO-PEAK JITTER AT THE OUTPUT PORT	Refer to clause 2/G.823

1.3.4.3.5.1. PRP/HSR redundant Ethernet communication interface

The PRP/HSR redundant Ethernet communication interface supports the two new IEC 62439-3 protocols which provide seamless redundancy for Ethernet networking in substations with zero-time recovery in case of a single failure without frame loss:

- PRP – Parallel Redundancy Protocol (IEC 62439-3 Clause 4)
- HSR – High-availability Seamless Redundancy (IEC 62439-3 Clause 5)

This interface uses two MM/LC connectors for double connection to networks as these protocols are based on the duplication of the sent frames.

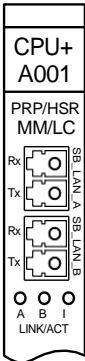

Figure 2-6 PRP/HSR connectors on a CPU+A001 module

1.3.4.3.5.2. Parallel Redundancy Protocol (PRP)

This redundancy protocol implements redundancy in the nodes as they are connected to two independent networks (LAN_A and LAN_B) sending a copy of each frame to both directions. The destination node receives and processes the first copy and discards the other copy of the sent frame.

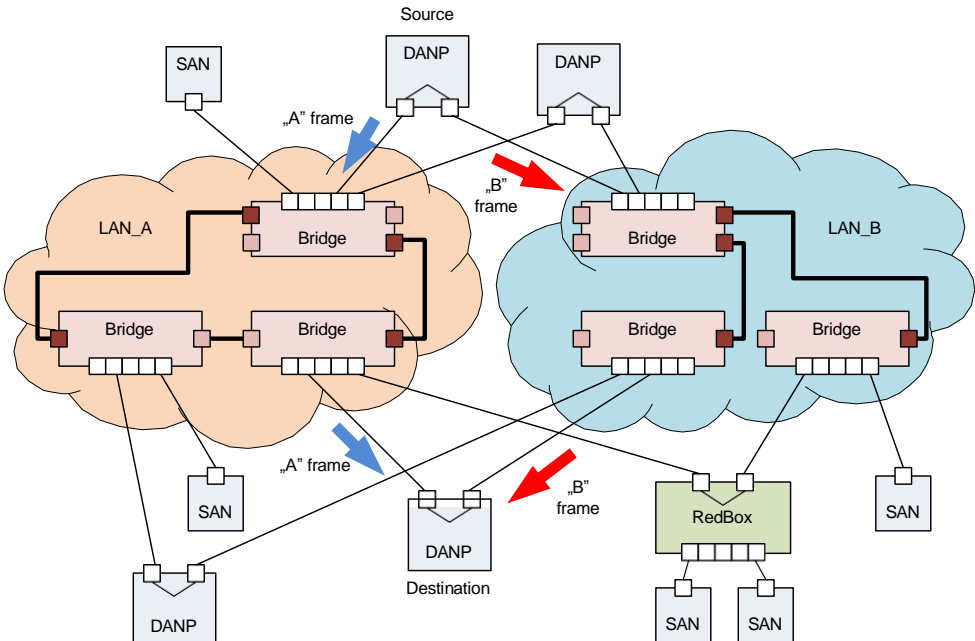

Figure 2-7 Example of a PRP redundant network

Single attached node (SAN): Network device that connects to a network with only one port.
 Double attached node implementing PRP (DANP): Network device which connects to a network with two ports implementing PRP redundancy.

1.3.4.3.5.3. High-availability Seamless Redundancy (HSR)

An HSR network provides redundancy with the same safety as PRP does with a lower cost. The principle of this protocol is also based on the duplication of the sent frames but in this solution the nodes are connected to a closed ring. A source node sends two copy of a frame to both direction and the destination node accepts the first received copy and discards the other one. If a frame returns to its source the node does not let it through itself prevent the possibility of an overload of the ring.

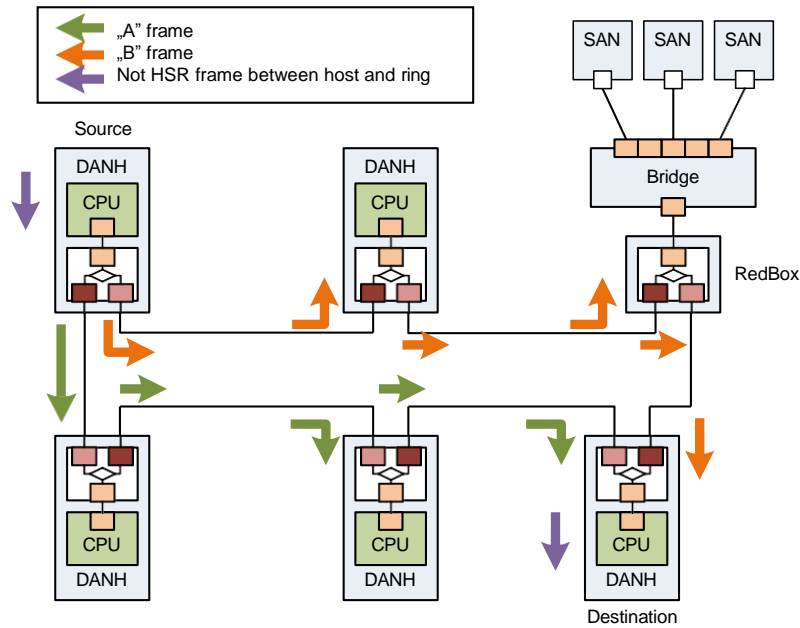
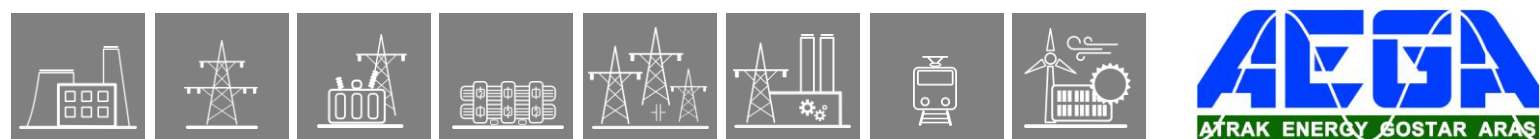

Figure 2-8 Example of an HSR redundant network

Single attached node (SAN): Network device that connects to a network with only one port.
Double attached node implementing HSR (DANH): Network device which connects to a network with two ports implementing HSR redundancy.



1.3.5. Device housings

Three+one versions are available: one is 84 HP wide with 21 module slots, the 42 HP wide, which supports 10 module slots, the double 42 HP wide with 20 module slots, and finally the 24 HP, which supports 6 module slots.

Depending on the installed modules of the configuration, the top and bottom panels of the 84 HP and 42 HP racks can be either solid (default) or perforated by 2 mm holes to prevent overheating. 24 HP housings do not have this feature, as the S24 system is less flexible, their range of the optional modules are narrower.

RACK CONFIGURATION	FREE MODULE SLOTS*	BOTTOM AND TOP PANELS	DISPLAY OPTIONS
84 HP, SINGLE RACK (3 U)	20	Solid, Perforated	3.5" TFT, 5.7" TFT
42 HP, SINGLE RACK (3 U)	9	Solid, Perforated	3.5" TFT, 5.7" TFT
42 HP, DOUBLE RACK (6 U)	19	Solid, Perforated	3.5" TFT
24 HP, PANEL INSTRUMENT CASE	5	Solid	B/W alphanumeric 3.5" TFT

**CPU module is mandatory, it uses up one fixed position*

Previously, a new rack type has been introduced to the 42HP devices. As of April 2021. this type is introduced to the 84HP devices as well. The depth of the box has been reduced from 242 mm to 223 mm. By default, this reduced-depth housing shall be used for newly manufactured devices. For more information about the previous and new size, see Chapter [22.1](#).

The following images showcase examples of the different types of available device housings with different kinds of front panel HMI. The available front panels are listed in Chapter 4.





<p>84 HP single rack (3 U) with 3.5" TFT display and solid housing</p>	
<p>84 HP single rack (3 U) with 5.7" TFT display and perforated housing</p>	
<p>42 HP single rack (3 U) with 3.5" TFT display and solid housing</p>	
<p>42 HP double rack (6 U) with 3.5" TFT display and solid housing</p>	
<p>24 HP panel instrument case with B/W display (left) TFT display (right)</p>	

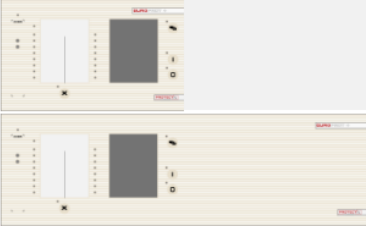



Figure 3-1 Rack configuration illustrations

1.3.6. Human-Machine Interface (HMI) module

The EuroProt+ device HMI consists of the following two main parts:

- Hardware: the HMI module, which is the front panel of the device, this is described here
- Software: the embedded web server and the menu system that is accessible through the HMI module. The web server is accessible via station bus, EOB interface or RJ-45 Ethernet connector. This is described in detail in the [Operating Manual](#) (external document).

1.3.6.1. Local HMI modules

MODULE TYPE	DISPLAY	SERVICE PORT	RACK SIZE	RACK DEPTH	ILLUSTRATION
HMI+/3505 HMI+/3405*	3,5" TFT	EOB	42 HP	Reduced	
			84 HP		
HMI+/3506 HMI+/3406* HMI+/3404*	3,5" TFT	RJ-45	42 HP	Reduced	
			Double 42HP		
			84 HP		
HMI+/5005	5,7" TFT	EOB	42 HP	Reduced	
HMI+/5006 HMI+/5004*	5,7" TFT	RJ-45	42 HP	Reduced	
			Double 42 HP		
HMI+/5706 HMI+/5704*	5,7" TFT	RJ-45	84 HP	Reduced	

**new display hardware requires CDSP firmware version 1560-H5 or higher!*

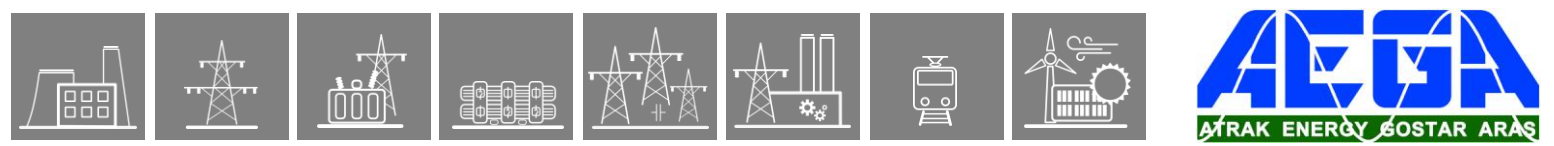

The following modules were made for the previous (now obsolete) racks (see Chapter 22.1), so they can be found in numerous devices. These became obsolete as well, **they are not recommended for new designs!**

MODULE TYPE	DISPLAY	SERVICE PORT	RACK SIZE	RACK DEPTH	ILLUSTRATION
HMI+/3501	3,5" TFT	EOB	42 HP	Normal	
			84 HP		
HMI+/3502	3,5" TFT	RJ-45	42 HP	Normal	
			84 HP		
HMI+/5001	5,7" TFT	EOB	42 HP	Normal	
HMI+/5002	5,7" TFT	RJ-45	42 HP	Normal	
HMI+/5701	5,7" TFT	EOB	84 HP	Normal	
HMI+/5702	5,7" TFT	RJ-45	84 HP	Normal	

1.3.6.2. Remote HMI

Protecta provides an alternative solution in that case if the IED can be only mounted in a non-practical way for managing the device via usual Human-Machine Interface.

By using a remote HMI (*terminal HMI device*), customers can place the HMI up to 3 meters far from the IED itself (*host device*) and mount the IED in any possible way that is applicable. The connection between the remote HMI and the IED is provided by a custom galvanic interface with DA-15 connector on the remote side.



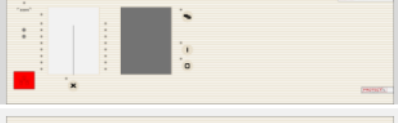
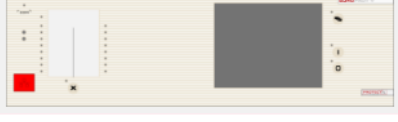

Figure 4-1 42 HP Remote HMI

Depending on the size of the HMI module you can use any applicable mounting methods that described in the [Mounting methods](#) chapter (Flush mounting, Semi-flush mounting, Rack mounting).



Figure 4-2 Remote HMI module with its host device

MODULE TYPE	DISPLAY	SERVICE PORT	RACK SIZE	RACK DEPTH	ILLUSTRATION
HMIT+/3505	3,5" TFT	EOB	42 HP	Reduced	
			84 HP		
HMIT+/3506	3,5" TFT	RJ-45	42 HP	Reduced	
			84 HP		
HMIT+/5706	5,7" TFT	RJ-45	84 HP	Reduced	

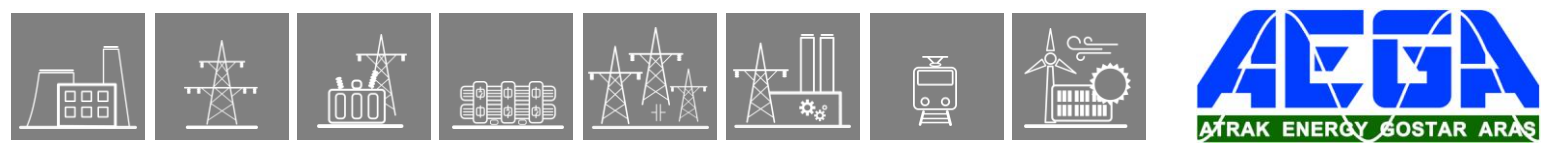



The following modules were made for the previous (now obsolete) racks (see Chapter 22.1), so they can be found in numerous devices. These became obsolete as well, **they are not recommended for new designs!**

MODULE TYPE	DISPLAY	SERVICE PORT	RACK SIZE	RACK DEPTH	ILLUSTRATION
HMIT+/3501	3,5" TFT	EOB	42 HP	Normal	
			84 HP		
HMIT+/3502	3,5" TFT	RJ-45	42 HP	Normal	
			84 HP		
HMIT+/5702	5,7" TFT	RJ-45	84 HP	Normal	

1.3.6.3. S24 HMI

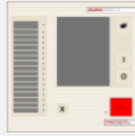
The S24 Smart Line devices have a different HMI family:

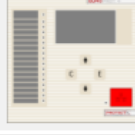
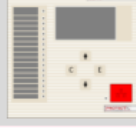
MODULE TYPE	DISPLAY	SERVICE PORT	RACK SIZE	MOUNTING	ILLUSTRATION
HMI+/2604* HMI+/2404 HMI+/2304**	3,5" TFT	RJ-45	24 HP	Normal	
HMI+/2606* HMI+/2406 HMI+/2306**	3,5" TFT	RJ-45	24 HP	DIN-rail	
HMI+/2704* HMI+/2504	B&W LCD	RJ-45	24 HP	Normal	
HMI+/2706* HMI+/2506	B&W LCD	RJ-45	24 HP	DIN-rail	

*for newer, modular-type S24 devices

**new display hardware requires CDSP firmware version 1560-H5 or higher!

The following module is **obsolete, it is not recommended for new designs!**

MODULE TYPE	DISPLAY	SERVICE PORT	RACK SIZE	MOUNTING	ILLUSTRATION
HMI+/2401*	3,5" TFT	EOB	24 HP	Normal	

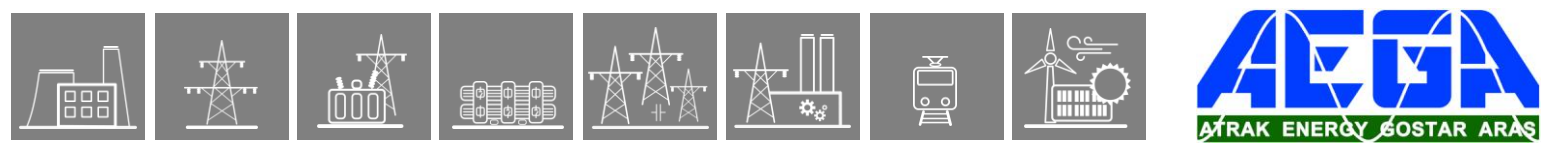

1.3.6.4. Parts of the HMI modules

The EuroProt+ device HMI on the front panel contains the following elements:

Function	Description
16 PIECES USER LEDs	Three-color, 3 mm circular LEDs
COM LED	Yellow, 3 mm circular LED indicating EOB/RJ-45 (on the front panel) communication link and activity
CAPACITIVE TOUCH KEY LEDs	4 pcs yellow, 3 mm circular LEDs indicating touch key actions
DEVICE STATUS LED	1 piece three-color, 3 mm circular LED Green: normal device operation Yellow: device is in warning state Red: device is in error state
DEVICE KEYS (I, O, X, PAGE)	Capacitive touch keys
	Tactile push buttons
BUZZER	Audible touch key pressure feedback
CHANGEABLE LED DESCRIPTION LABEL	Describes user LED functionality
DISPLAY	320 × 240 pixel TFT color display with resistive touchscreen interface (3.5" or optional 5.7")
	128 × 64 LCD black & white display
OPTICAL INTERFACE FOR FACTORY USAGE	For debugging and software development purposes <i>Only for 42 HP and 84 HP devices.</i>
EOB CONNECTOR	Ethernet Over Board: communication interface accomplishes isolated, non-galvanic Ethernet connection with the help of a magnetically attached EOB device. The EOB device has an RJ-45 type connector supporting Ethernet connection to the user computer. This is a proprietary and patented solution from Protecta Ltd. EOB1: Supporting 10Base-T Ethernet connection. Passive device with one RJ45 type connector. Obsolete module. EOB2: Supporting 10/100Base-Tx Ethernet connection. An active device that has a USB port in addition to the RJ45 connector for powering up.
ETHERNET SERVICE PORT	IP56 rated Ethernet 10/100-Base-T interface with RJ-45 type connector (IP56 only valid if the cap of the service port is closed.)

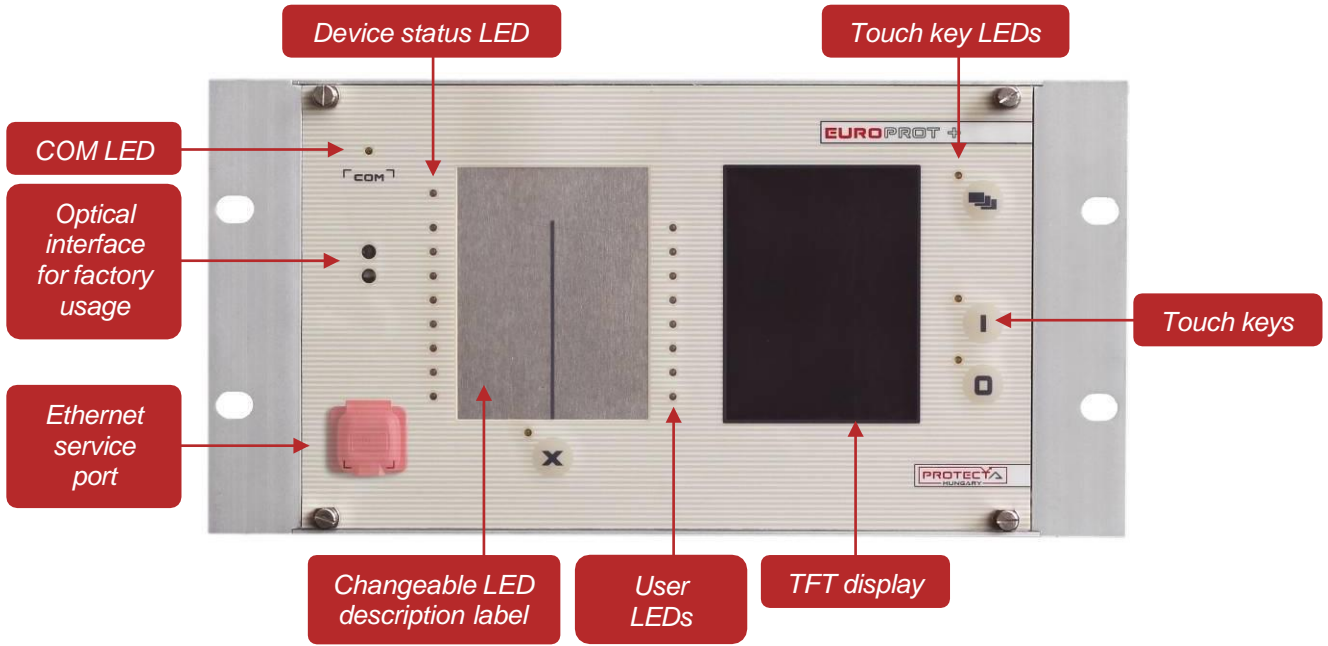

Figure 4–3 HMI signals and controls

LCD dot-defect handling policy

The definitions of dot-defect are as below:

- The defect area of the dot must be bigger than half of a dot.
- For bright dot-defect (sparkle mode), showing black pattern, the dot's brightness must be over 30 % brighter than others at black raster.
- For dark dot-defect (black mode), showing white pattern, the dot's brightness must be under 70 % darker than others at R.G.B. raster.

DOT-DEFECT TYPE		MAXIMUM NUMBER ACCEPTABLE	
		3.5"	5.7"
SPARKLE MODE	1 dot	4	4
	2 dots	2 (sets)	1
	IN TOTAL	4	5
BLACK MODE	1 dot	4	5
	2 dots	2 (sets)	2
	IN TOTAL	4	5
SPARKLE MODE AND BLACK MODE	2 dots	2 (sets)	n/a
IN TOTAL		6	10

For further information please contact our Application Team. (application@protecta.hu)

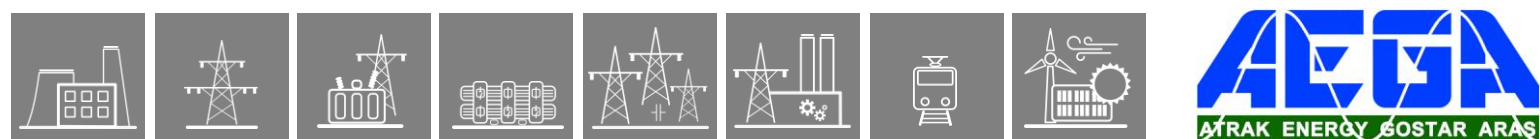

1.3.7. Current input module

This is an input module with intermediate current transformers to input the phase currents and the zero-sequence current. The rated current for the phase current and for the zero-sequence current can be selectable by parameter.

Main features:

- Rated frequency: 50 Hz, 60 Hz
- *Electronic* iron-core flux compensation

Connector types:

- *The default and optionally available connector types are indicated for each module in the tables below. See Chapter 20.2 for details about each type.*

MODULE TYPE	CT+/0101		CT+/1111*		CT+/1155		CT+/1500	
CHANNEL NUMBER	1 – 4		1 – 4		1 – 4		1 – 3	
SELECTABLE RATED CURRENT, I_N [A]	0.04	0.2	1	5	1	5	1	5
MAX. MEASURED CURRENT ($\pm 10\%$)	$8 \times I_N$		$50 \times I_N$		$12.5 \times I_N$		$2 \times I_N$	
POWER CONSUMPTION AT RATED CURRENT [VA]	0.005	0.1	0.01	0.25	0.02	0.45	0.1	1.55
THERMAL WITHSTAND [A]								
CONTINUOUSLY	7		20		20		7	
10 s	50		175		120		50	
1 s	150		500		380		150	
10 ms	330		1200		850		330	
CONNECTOR TYPE	<u>Default:</u> STVS <u>Options:</u> -		<u>Default:</u> STVS <u>Options:</u> -		<u>Default:</u> STVS <u>Options:</u> -		<u>Default:</u> STVS <u>Options:</u> R	
RECOMMENDED APPLICATION	DEFL earth fault protection		Special disturbance recorder application in wider frequency range		Special protection applications where the overcurrent in the secondary circuit can not exceed $10 \times I_N$		General three-phase measurement	

***Obsolete module. These modules are not recommended for new designs!**

MODULE TYPE	CT+/1515*		CT+/2500*		CT+/5101			
CHANNEL NUMBER	1 – 4		1 – 3		1 – 3		4	
SELECTABLE RATED CURRENT, I_N [A]	1	5	1	5	1	5	0.2	1
MAX. MEASURED CURRENT ($\pm 10\%$)	$2 \times I_N$		$2 \times I_N$		$50 \times I_N$		$12.5 \times I_N$	
POWER CONSUMPTION AT RATED CURRENT [VA]	0.1	1.55	0.1	1.55	0.01	0.25	0.005	0.1
THERMAL WITHSTAND [A]								
CONTINUOUSLY	7		7		20		7	
10 s	50		50		175		50	
1 s	150		150		500		150	
10 ms	330		330		1200		330	
CONNECTOR TYPE	<u>Default:</u> STVS <u>Options:</u> -		<u>Default:</u> STVS <u>Options:</u> -		<u>Default:</u> STVS <u>Options:</u> -			
RECOMMENDED APPLICATION	Special disturbance recorder application		Generator protections		Extremely sensitive earth-fault applications			

***Obsolete module. These modules are not recommended for new designs!**

MODULE TYPE	CT+/5102				CT+/5111*			
CHANNEL NUMBER	1 – 3		4		1 – 3		4	
SELECTABLE RATED CURRENT, I_N [A]	1	5	0.2	1	1	5	0.001	0.005
MAX. MEASURED CURRENT ($\pm 10\%$)	$50 \times I_N$		$50 \times I_N$		$50 \times I_N$		$50 \times I_N$	
POWER CONSUMPTION AT RATED CURRENT [VA]	0.01	0.25	0.001	0.01	0.01	0.25	0.005	0.1
THERMAL WITHSTAND [A]								
CONTINUOUSLY	20		20		20		7	
10 s	175		120		175		50	
1 s	500		380		500		150	
10 ms	1200		850		1200		330	
CONNECTOR TYPE	<u>Default:</u> STVS <u>Options:</u> -				<u>Default:</u> STVS <u>Options:</u> R			
RECOMMENDED APPLICATION	Sensitive earth-fault applications				Sensitive earth-fault applications			

***Obsolete module. These modules are not recommended for new designs!**

MODULE TYPE	CT+5115		CT+5116		CT+/5151		CT+/5152	
CHANNEL NUMBER	1 – 4		1 – 3		1 – 4		1 – 4	
SELECTABLE RATED CURRENT, I_N [A]	1	5	1	5	1	5	1	5
MAX. MEASURED CURRENT ($\pm 10\%$)	$50 \times I_N$		$50 \times I_N$		$50 I_N$		$50 I_N$	
POWER CONSUMPTION AT RATED CURRENT [VA]	0.01	0.25	0.01	0.25	0.01	0.25	0.01	0.25
THERMAL WITHSTAND [A]								
CONTINUOUSLY	20		20		20		20	
10 s	175		175		175		175	
1 s	500		500		500		500	
10 ms	1200		1200		1200		1200	
CONNECTOR TYPE	<u>Default:</u> STVS <u>Options:</u> R		<u>Default:</u> STVS <u>Options:</u> -		<u>Default:</u> STVS <u>Options:</u> R		<u>Default:</u> STVS <u>Options:</u> R	
RECOMMENDED APPLICATION	<ul style="list-style-type: none"> General protection applications* Three-phase measurement* 		High-impedance differential protection		General protection applications		Busbar protection bay units	

*The CT+/5115 module handles both applications: it can be connected to the protection and measurement core of the primary CT as well

MODULE TYPE	CT+/5153					CT+/5154*				
CHANNEL NUMBER	1 – 3		4			1 – 3		4		
SELECTABLE RATED CURRENT, I_N [A]	1	5	1	0.2	0.2 sens.	1	5	5	1	0.2
MAX. MEASURED CURRENT ($\pm 10\%$)	$50 \times I_N$			$10 \times I_N$		$50 \times I_N$			$10 \times I_N$	
POWER CONSUMPTION AT RATED CURRENT [VA]	0.06	1.3	0.6	0.004	0.0004	0.06	1.3	1.3	0.06	0.004
THERMAL WITHSTAND [A]										
CONTINUOUSLY	20		7			20				
10 s	175		50			175				
1 s	500		150			500				
10 ms	1200		330			1200				
CONNECTOR TYPE	<u>Default:</u> STVS <u>Options:</u> R, T**					<u>Default:</u> STVS <u>Options:</u> R				
RECOMMENDED APPLICATION	General protection application, extremely sensitive transient earth-fault protections					General protection application, sensitive transient earth-fault protections				

***Obsolete module. These modules are not recommended for new designs!**

**The connector remains the same STVS, only the handle of the module becomes narrower and will be made of aluminum

MODULE TYPE	CT+/5155*					CT+/5253**				
CHANNEL NUMBER	1 – 3		4			1 – 3		4		
SELECTABLE RATED CURRENT, I_N [A]	1	5	0.25	0.05	0.05 sens.	5	1	0.25	0.05	0.05 sens.
MAX. MEASURED CURRENT ($\pm 10\%$)	$50 \times I_N$			$10 \times I_N$		$25 \times I_N$				
POWER CONSUMPTION AT RATED CURRENT [VA]	0.06	1.3	0.6	0.004	0.0004	0.06	1.3	0.6	0.004	0.0004
THERMAL WITHSTAND [A]										
CONTINUOUSLY	20		7			20		7		
10 s	175		50			175		50		
1 s	500		150			500		150		
10 ms	1200		330			1200		330		
CONNECTOR TYPE	Default: STVS Options: -					Default: STVS Options: -				
RECOMMENDED APPLICATION	DMD Special sensitive earth fault protection					Circuit breaker diagnostics				

***Obsolete module. These modules are not recommended for new designs!**

****Special module**

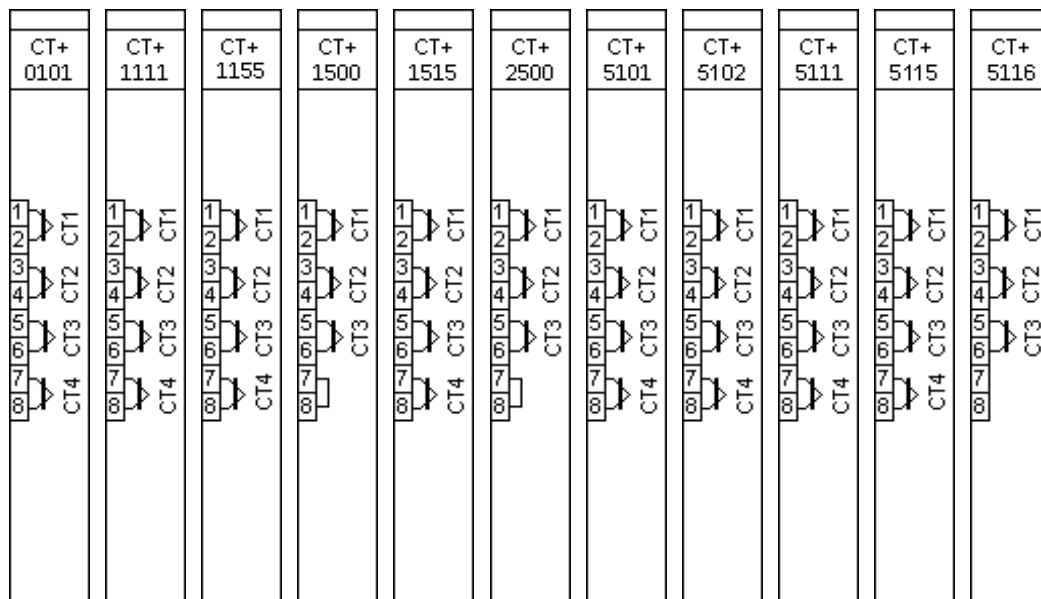

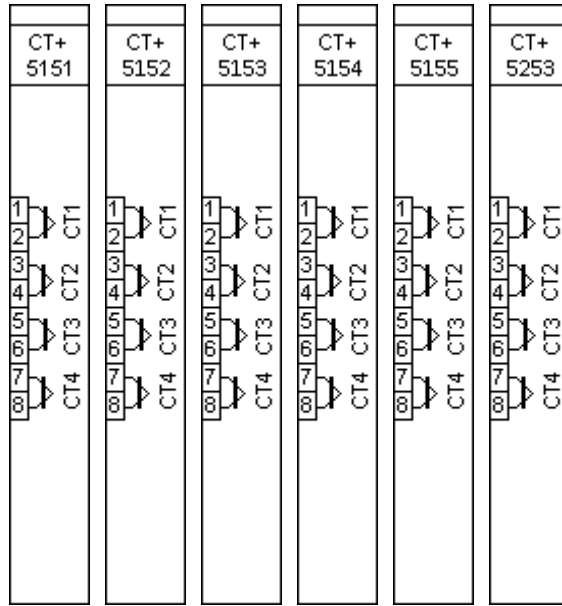
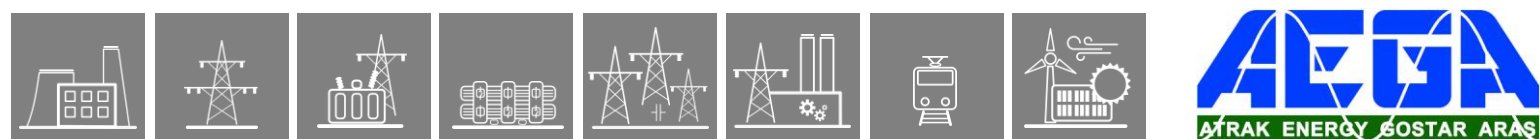

Figure 5-1 CT modules



1.3.8. Voltage input module

If the device performs voltage and/or frequency related functions and measurements (voltage protections, directional protections, frequency protections etc.), then this module is needed.

Connector types:

- The default and optionally available connector types are indicated for each module in the tables below. See Chapter 20.2 for details about each type.

MODULE TYPE	VT+/2211	VT+/2212*	VT+/2215**
CHANNEL NUMBER	4	4	4
SELECTABLE VOLTAGE RANGE	<u>Type 100:</u> $\frac{100}{\sqrt{3}}$, 100 V <u>Type 200:</u> $\frac{200}{\sqrt{3}}$, 200 V	<u>Type 100:</u> $\frac{100}{\sqrt{3}}$, 100 V <u>Type 200:</u> $\frac{200}{\sqrt{3}}$, 200 V	<u>Type 100:</u> $\frac{100}{\sqrt{3}}$, 100 V <u>Type 200:</u> $\frac{200}{\sqrt{3}}$, 200 V
CONTINUOUS VOLTAGE WITHSTAND	200 V	200 V	200 V
SHORT TIME OVERLOAD (1 s)	275 V (10s)	275 V	275 V
VOLTAGE MEASURING RANGE ($\pm 10\%$)	0.05 U _N – 1.3 U _N	0.05 U _N – 1.3 U _N	0.05 U _N – 1.3 U _N
POWER CONSUMPTION OF VOLTAGE INPUT	0.61 VA at 200 V 0.2 VA at 100 V	0.61 VA at 200 V 0.2 VA at 100 V	ch. 1-3: 0.61 VA at 200 V 0.2 VA at 100 V ch. 4: 50 mVA at 100 V
CONNECTOR TYPE	<u>Default:</u> BLA <u>Options:</u> F, T, R	<u>Default:</u> BLA <u>Options:</u> -	<u>Default:</u> BLA <u>Options:</u> -
RECOMMENDED APPLICATION	General protection applications.	Special disturbance recorder application in wider frequency range	Special protection applications with voltage transformers that require low power consumption on the 4 th channel.

***Obsolete module. These modules are not recommended for new designs!**

**Special module

MODULE TYPE	VT+/2245	VT+/2246*
CHANNEL NUMBER	4	3
SELECTABLE VOLTAGE RANGE	Type 200: $\frac{200}{\sqrt{3}}$, 200 V Type 400: $\frac{400}{\sqrt{3}}$	
CONTINUOUS VOLTAGE WITHSTAND	400 V	
SHORT TIME OVERLOAD (1 s)	420 V	420 V (10 s)
VOLTAGE MEASURING RANGE ($\pm 10\%$)	0.05 U _N – 1.3 U _N	
POWER CONSUMPTION OF VOLTAGE INPUT	0.21 VA at 200 V 0.28 VA at 230 V	
CONNECTOR TYPE	Default: BLA Options: T	Default: BLA Options: -
RECOMMENDED APPLICATION	Protection applications for 400 V AC secondary voltage	Special protection applications for 400 V AC secondary voltage and increased isolation to 6 kV

*Special module

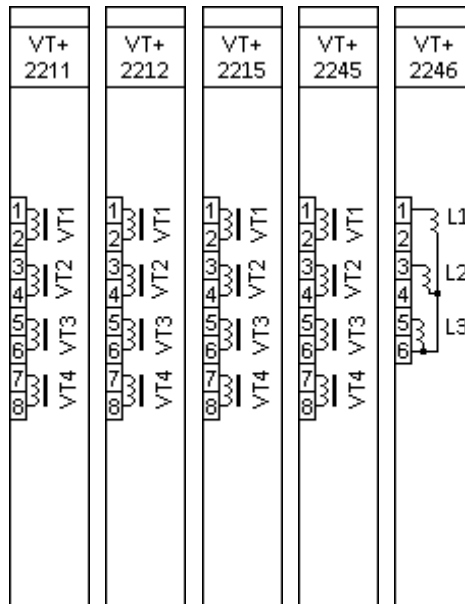
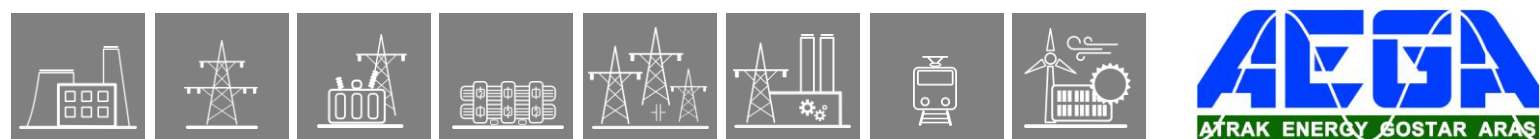

Figure 6-1 VT modules



1.3.9. Binary input module

The inputs are galvanic isolated, and the module converts high-voltage signals to the voltage level and format of the internal circuits. The inputs of this module can be also programmed to serve as a PPM input for time synchronization.

Connector types:

- The default and optionally available connector types are indicated for each module in the tables below. See Chapter 20.2 for details about each type.

Notes for the following tables:

- **Thermal withstand voltage:** continuous with 60 % of the input channels are energized.
- **Clamp voltage:** these are the guaranteed values; the actual ones might differ from those provided here (falling and rising around $0.66 U_N$ and $0.77 U_N$, respectively)

MODULE TYPE	O8+/2401	O8+/4801	O8+/1101	O8+/2201
CHANNEL NUMBER	8	8	8	8
TIME SYNCHRONIZATION	configured by EuroCAP	configured by EuroCAP	configured by EuroCAP	configured by EuroCAP
RATED VOLTAGE	24 V	48 V	110 V	220 V
THERMAL WITHSTAND VOLTAGE	72 V	100 V	250 V	320 V
CLAMP VOLTAGE	falling $0.64 U_N$ rising $0.8 U_N$	falling $0.64 U_N$ rising $0.8 U_N$	falling $0.64 U_N$ rising $0.8 U_N$	falling $0.64 U_N$ rising $0.8 U_N$
COMMON GROUPS	independent	independent	independent	independent
CONNECTOR TYPE	<u>Default:</u> BLA <u>Options:</u> T	<u>Default:</u> BLA <u>Options:</u> T	<u>Default:</u> BLA <u>Options:</u> T	<u>Default:</u> BLA <u>Options:</u> T

MODULE TYPE	O12+/2401	O12+/4801	O12+/1101	O12+/2201
CHANNEL NUMBER	12	12	12	12
TIME SYNCHRONIZATION	configured by EuroCAP	configured by EuroCAP	configured by EuroCAP	configured by EuroCAP
RATED VOLTAGE	24 V	48 V	110 V	220 V
THERMAL WITHSTAND VOLTAGE	72 V	72 V	250 V	320 V
CLAMP VOLTAGE	falling $0.64 U_N$ rising $0.8 U_N$	falling $0.64 U_N$ rising $0.8 U_N$	falling $0.64 U_N$ rising $0.8 U_N$	falling $0.64 U_N$ rising $0.8 U_N$
COMMON GROUPS	4 × 3 common	4 × 3 common	4 × 3 common	4 × 3 common
CONNECTOR TYPE	<u>Default:</u> BLA <u>Options:</u> T	<u>Default:</u> BLA <u>Options:</u> F, T	<u>Default:</u> BLA <u>Options:</u> F, T	<u>Default:</u> BLA <u>Options:</u> T

MODULE TYPE	O12+/4201*	O12+/2101*	O15+/4801T	O15+/1101T
CHANNEL NUMBER	12	12	15	15
TIME SYNCHRONIZATION	configured by EuroCAP	configured by EuroCAP	configured by EuroCAP	configured by EuroCAP
RATED VOLTAGE	24 V DC / 48 V DC user selectable on channel basis by jumpers	110 V DC / 220 V DC user selectable on channel basis by jumpers	48 V	110 V
THERMAL WITHSTAND VOLTAGE	72 V	320 V	100 V	250 V
CLAMP VOLTAGE	falling 0.64 U _N rising 0.8 U _N	falling 0.64 U _N rising 0.8 U _N	falling 0.64 U _N rising 0.8 U _N	falling 0.64 U _N rising 0.8 U _N
COMMON GROUPS	4 × 3 common	4 × 3 common	1 × 15 common	1 × 15 common
CONNECTOR TYPE	<u>Default:</u> BLA <u>Options:</u> -	<u>Default:</u> BLA <u>Options:</u> T	BLT	BLT

* O12+2101 and O12+4201 modules can be used only in demonstration applications! For further information see our [Product availability](#) chapter.

MODULE TYPE	O16+/2401*	O16+/4801*	O16+/1101*	O16+/2201*
CHANNEL NUMBER	16	16	16	16
TIME SYNCHRONIZATION	-	-	-	-
RATED VOLTAGE	24 V	48 V	110 V	220 V
THERMAL WITHSTAND VOLTAGE	72 V	100 V	250 V	320 V
CLAMP VOLTAGE	falling 0.64 U _N rising 0.8 U _N	falling 0.64 U _N rising 0.8 U _N	falling 0.64 U _N rising 0.8 U _N	falling 0.64 U _N rising 0.8 U _N
COMMON GROUPS	2 × 8 common	2 × 8 common	2 × 8 common	2 × 8 common
CONNECTOR TYPE	<u>Default:</u> BL 3.5 <u>Options:</u> -	<u>Default:</u> BL 3.5 <u>Options:</u> -	<u>Default:</u> BL 3.5 <u>Options:</u> -	<u>Default:</u> BL 3.5 <u>Options:</u> -

*Obsolete module. These modules are not recommended for new designs! O15+ modules are recommended instead (see above).

Main features:

- Digitally filtered per channel
- Current drain:
 - max. 1.6 mA per channel at 220 V DC
 - max. 1.8 mA per channel at 110 V DC
 - max. 2 mA per channel at 48 V DC
 - max. 3 mA per channel at 24 V DC
- In such applications where the input voltage is 60 V the modules with 48 V rated voltage can be used.
- Input voltage type can be either DC or AC voltage. If AC voltage is used make sure that the type and the parameters of the binary inputs are configured properly in EuroCAP tool.

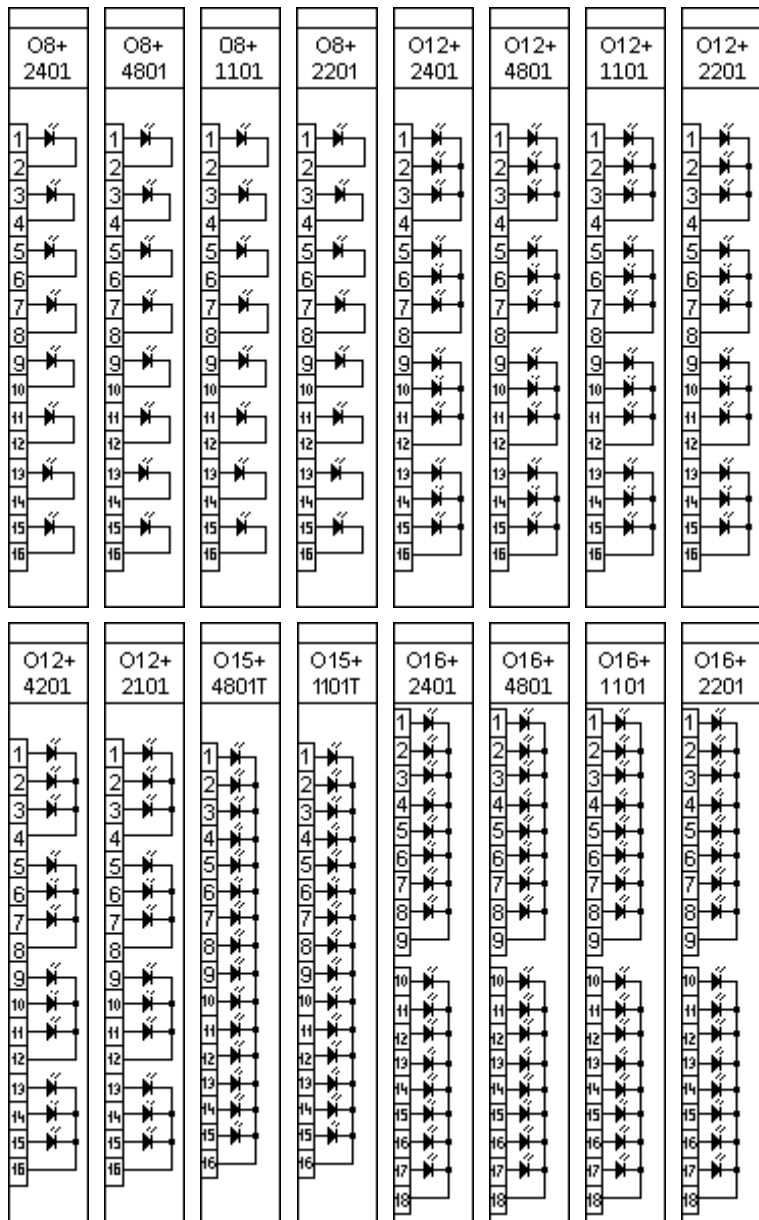
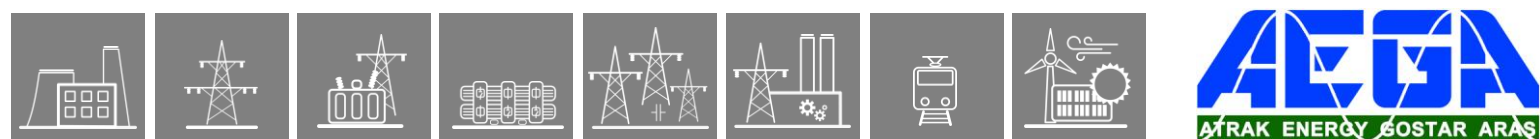

Figure 7-1 Binary input modules



1.3.10. Signaling module

The signaling module has 4, 8, 12 or 16 relay outputs with dry contacts.

Connector types:

- The default and optionally available connector types are indicated for each module in the tables below. See Chapter 20.2 for details about each type.

MODULE TYPE	R4+/01	R8+/00	R8+/80	R8+/C0
RATED VOLTAGE	250 V AC/DC	250 V AC/DC	250 V AC/DC	250 V AC/DC
CONTINUOUS CARRY	8 A	8 A	8 A	8 A
CONTACT VERSIONS	4 CO	8 NO	CH8 NC others NO	CH7 and CH8 NC others NO
GROUP ISOLATION	4 independent	8 independent	8 independent	8 independent
CONNECTOR TYPE	<u>Default:</u> BLA <u>Options:</u> F	<u>Default:</u> BLA <u>Options:</u> F, T	<u>Default:</u> BLA <u>Options:</u> T	<u>Default:</u> BLA <u>Options:</u> T

MODULE TYPE	R8+/FF	R12+/0000	R12+/4000
RATED VOLTAGE	250 V AC/DC	250 V AC/DC	250 V AC/DC
CONTINUOUS CARRY	8 A	8 A	8 A
CONTACT VERSIONS	8 NC	12 NO	CH12 NC others NO
GROUP ISOLATION	8 independent	4 × 3 common	4 × 3 common
CONNECTOR TYPE	<u>Default:</u> BLA <u>Options:</u> -	<u>Default:</u> BLA <u>Options:</u> F, T	<u>Default:</u> BLA <u>Options:</u> F, T

MODULE TYPE	R16+/0000	R16+/8000	R16+/8080
RATED VOLTAGE	250 V AC/DC	250 V AC/DC	250 V AC/DC
CONTINUOUS CARRY	8 A	8 A	8 A
CONTACT VERSIONS	16 NO	CH16 NC others NO	CH16 and CH8 NC others NO
GROUP ISOLATION	2 × 8 common	2 × 8 common	2 × 8 common
CONNECTOR TYPE	<u>Default:</u> BLA <u>Options:</u> -	<u>Default:</u> BLA <u>Options:</u> -	<u>Default:</u> BLA <u>Options:</u> -

MODULE TYPE	R4S+/01*	R4S+/16*	R1T+/0001***
RATED VOLTAGE	250 V AC/DC	250 V AC/DC	320 V AC/DC
CONTINUOUS CARRY	8 A 120 mA**	120 mA	32 A
CONTACT VERSIONS	4 CO (1 SSR, 3 normal)	4 CO (4 SSR)	1 NO
GROUP ISOLATION	4 independent	4 independent	1 independent
CONNECTOR TYPE	<u>Default:</u> BLA <u>Options:</u> -	<u>Default:</u> BLA <u>Options:</u> -	<u>Default:</u> BLA <u>Options:</u> -

*Modules with **solid-state relays (SSR)**

**If the signaling is performed via the solid-state relay the continuous carry value is 120 mA.

*****Thyristor module**. Can be used only unipolarly. For further information see our Product availability chapter.

Main features (according to IEC 60255-1):

- Maximum switching voltage: 400 V AC
- Breaking capacity: (L/R=40 ms) at 220 V DC: 0.2 A, at 110 V DC: 0.3 A
- Breaking capacity max.: 2000 VA
- Short time carrying capacity: 1 s, 35 A
- Limiting making current, max. 4 s: 15 A (df = 10 %)
- Dielectric strength between open contacts, 1 min: 1000 V_{RMS}
- Mechanical endurance: 10 × 10⁶ cycles
- Circuit closing capability: typically 10 ms, maximally 22 ms, with SSR 0.5 ms.
- Bounce time: typically 6,5 ms, maximally 10 ms, with SSR 0.5 ms.
- Minimal switching requirement: 5 V
- *The signaling is also performed via a solid-state relay (SSR) channel on R4S+01 and R4S+16 module*

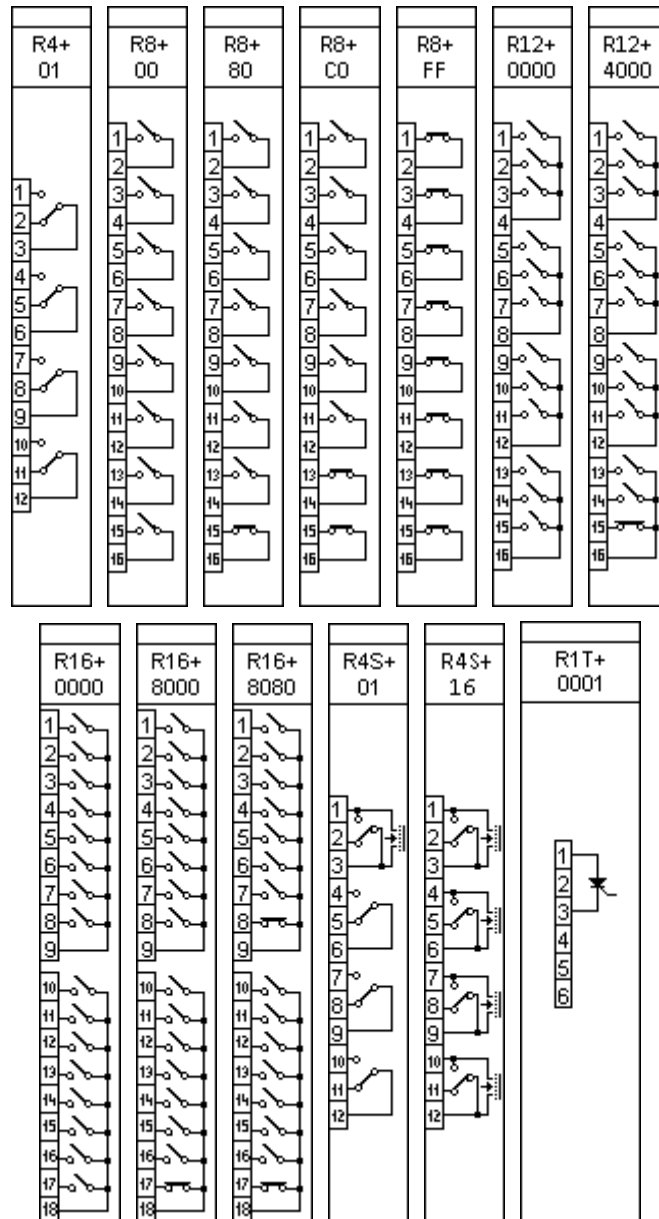

Figure 8-1 Signaling modules

1.3.11. Tripping module

The tripping module is a proprietary and patented solution that facilitates direct control of a circuit breaker.

Connector types:

- The default and optionally available connector types are indicated for each module in the table below. See Chapter 20.2 for details about each type.

MODULE TYPE	TRIP+/4201	TRIP+1101*	TRIP+/2101	TRIP+/21F1**	TRIP+/2201
CHANNEL NUMBER	4	4	4	4	4
RATED VOLTAGE	24 V DC and 48 V DC	110 V DC	110 V DC	110 V DC	220 V DC
THERMAL WITHSTAND VOLTAGE	72 V DC	242 V DC	150 V DC	150 V DC	242 V DC
CONTINUOUS CARRY	8 A	8 A	8 A	8 A	8 A
MAKING CAPACITY	0.5 s, 30 A	0.5 s, 30 A	0.5 s, 30 A	0.5 s, 30 A	0.5 s, 30 A
BREAKING CAPACITY	L/R = 40 ms: 4 A DC	L/R = 40 ms: 4 A DC	L/R = 40 ms: 4 A DC	L/R = 40 ms: 4 A DC	L/R = 40 ms: 4 A DC
CONNECTOR TYPE	<u>Default:</u> BLA <u>Options:</u> F, T	<u>Default:</u> BLA <u>Options:</u> -	<u>Default:</u> BLA <u>Options:</u> F, T	<u>Default:</u> BLA <u>Options:</u> T	<u>Default:</u> BLA <u>Options:</u> T

***Obsolete module. These modules are not recommended for new designs!**

****Without trip circuit supervision.**

Main features:

- High-speed operation: with pre-trip 0.5 ms, without pre-trip typically 10 ms, maximally 22 ms.
- Trip circuit supervision for each trip contact, except TRIP+21F1
- With 2-wire wiring, the tripping output can be *dry* contact type, too

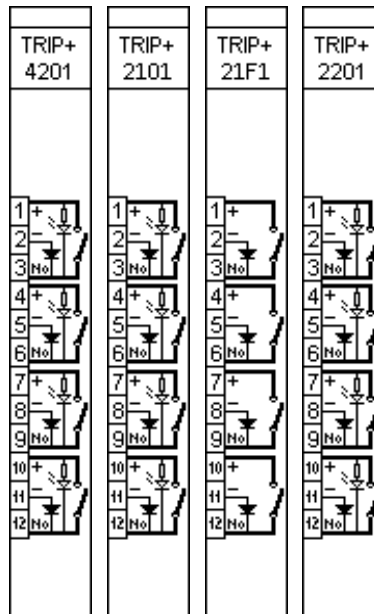

Figure 9-1 Tripping modules

1.3.11.1. TRIP+ module wiring

The tripping module provides tripping circuit supervision function (TCS). The wiring of these modules can be 2-wire or 3-wire. (TCS function is active for all wiring methods.)

The voltage of the "No" contact is maximized at 15 V by a Zener-diode. Make sure that the voltage caused by the resistance of the circuit breaker and the injected current from the TRIP+ module does not reach 10 V.

Our TRIP+ modules are improved to switch DC circuits. **Using reversed polarity or AC voltage can cause the damage of the internal circuits. Improper wiring might cause improper operation!**

1.3.11.1.1. 3-wire TRIP+ wiring methods

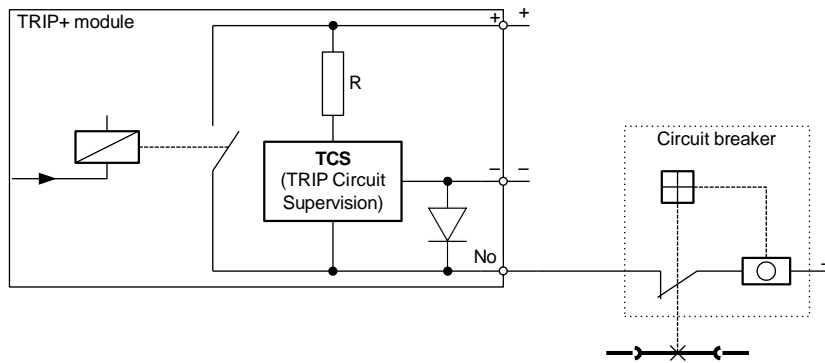

Figure 9-2 3-wire TRIP+ wiring

It is possible to use parallel connected TRIP+ modules. In this case the negative terminals must be common.

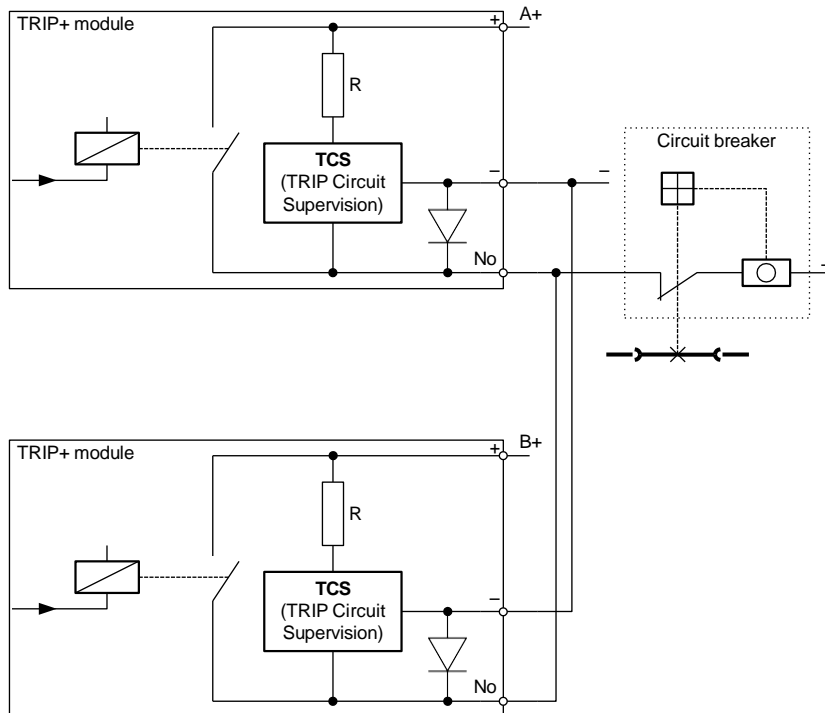

Figure 9-3 3-wire TRIP+ wiring using parallel connected TRIP+ modules

1.3.11.1.2. 2-wire TRIP+ wiring methods

If necessary, the TRIP+ modules can be wired using only the “+” and the “No” contacts.

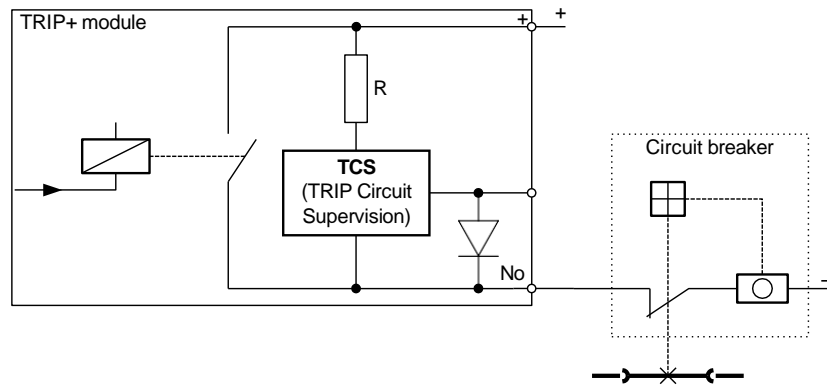

Figure 9-4 2-wire TRIP+ wiring

It is possible to use parallel connected TRIP+ modules.

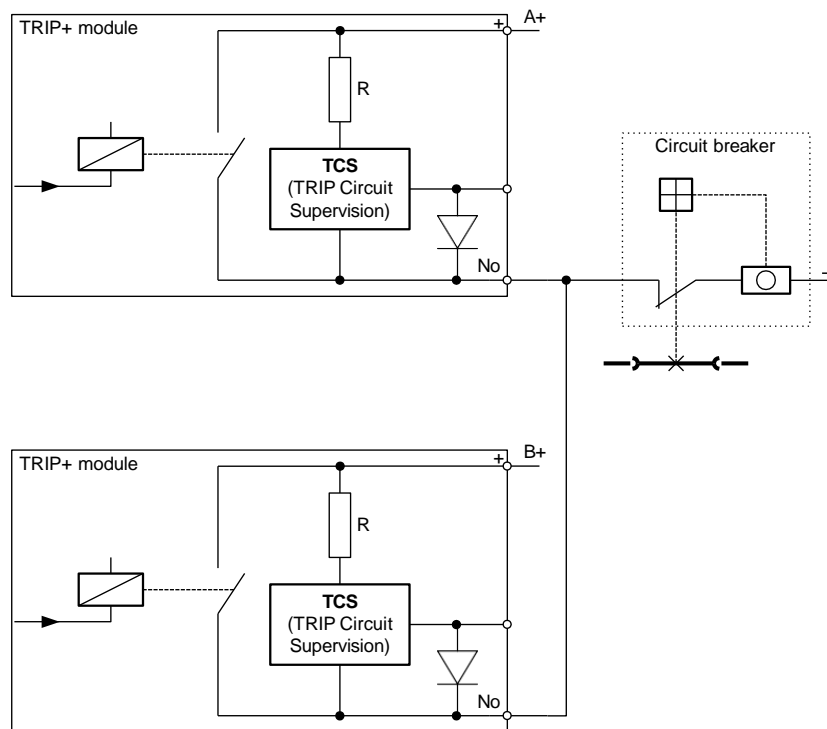

Figure 9-5 2-wire TRIP+ wiring using parallel connected TRIP+ modules

If the circuit breaker needs two-pole switching TRIP+ modules can be connected series as you can see in Figure 9–6.

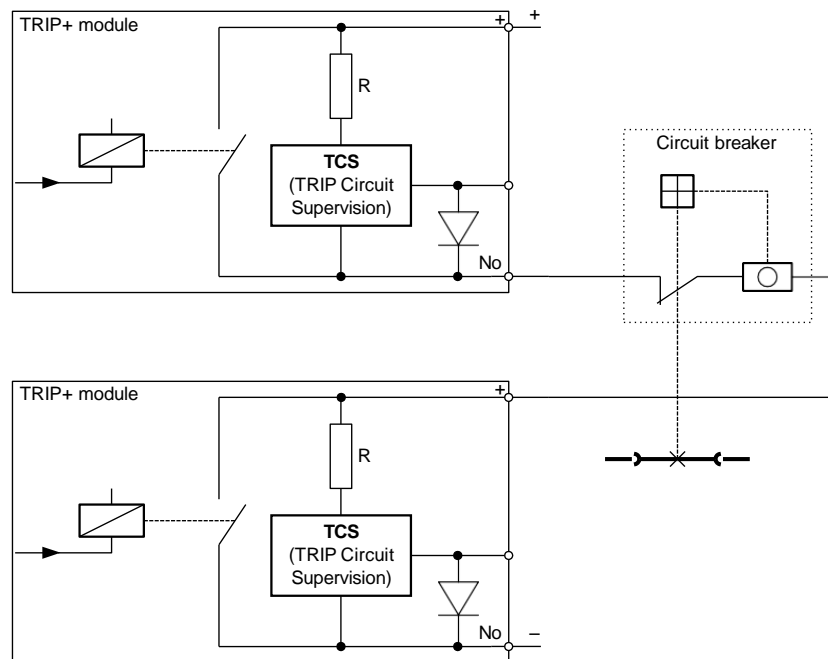

Figure 9-6 2-wire TRIP+ wiring using series connected TRIP+ modules

1.3.11.2. Trip Circuit Supervision (TCS)

Apart from the TRIP+/21F1, all TRIP modules have TCS. The feature is described in detail (tech. data, instructions, etc.) in a separate document:

https://www.protecta.hu/downloads/tcs_en

The technical data of the TCS is shown here as well:

MODULE TYPE	TRIP+/4201	TRIP+/2101	TRIP+/2201	
VALUE OF R RESISTOR (± 10 %)	10 kΩ	73 kΩ	130 kΩ	
INJECTED CURRENT AT "NO" CONTACT	2.4 mA @ 24 V DC 4.8 mA @ 48 V DC	1.5 mA @ 110 V DC	1.7 mA @ 220 V DC	
MAXIMUM RESISTANCE OF THE TRIP COIL	3-WIRE WIRING (MAX. 10 V)	11.8 kΩ @ 24 V DC 3.7 kΩ @ 48 V DC	9.7 kΩ @ 110 V DC 8.4 kΩ @ 125 V DC	8.1 kΩ @ 220 V DC
	3-WIRE WIRING WITH IN PARALLEL (MAX. 10 V)	5.9 kΩ @ 24 V DC 1.8 kΩ @ 48 V DC	4.8 kΩ @ 110 V DC 4.2 kΩ @ 125 V DC	4 kΩ @ 220 V DC
	2-WIRE METHOD (1 mA MIN. CURRENT)	14 kΩ @ 24 V DC 38 kΩ @ 48 V DC	37 kΩ @ 110 V DC 52 kΩ @ 125 V DC	90 kΩ @ 220 V DC

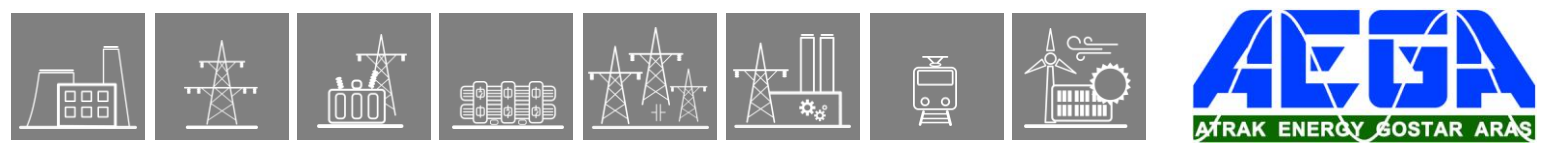

1.3.11.3. Relay output modules of the EuroProt+ system

1.3.11.3.1. Types of the relay output modules of the EuroProt+ system

Basically there are two different types of relay output modules in the EuroProt+ devices: TRIP relay output module for high-speed operation of the circuit breakers Signal relay output module

1.3.11.3.2. Operating modes of the relay contacts

For operation of the relay output modules there are four different modes:

Application of TRIP relays for commands of fast protection functions

User application of the TRIP relays Fast operation of any relay contacts (TRIP relays or signal relays) Control of signal relay outputs.

The procedures of command processing are shown in. This document describes the details using the TRIP relay contacts as an example.

The left side of the Figure shows the available sources of the trip commands:

The functionblocks, configured in the device,

The communication channels to the SCADA system,

Commands generated using the front panel LCD of the device,

Any other binary signals, e.g. signals from the binary inputs of the device.

The right side of the Figure shows one of the TRIP relays symbolically.

The Figure provides a survey of the configured trip command processing methods. In the middle of the Figure, the locations indicated by "User" shows the possibilities for the user to modify the procedures. All other parts are factory programmed.

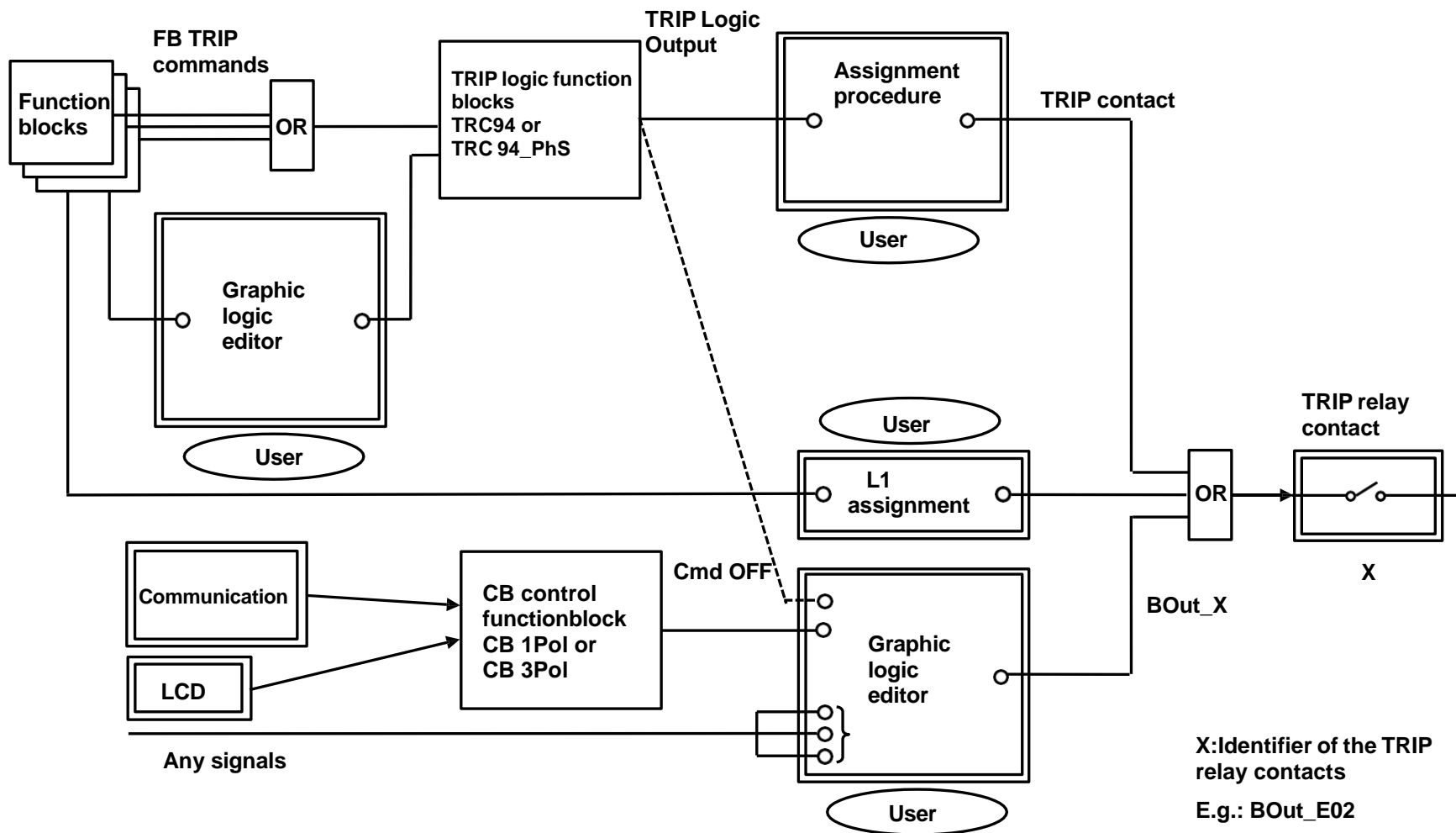
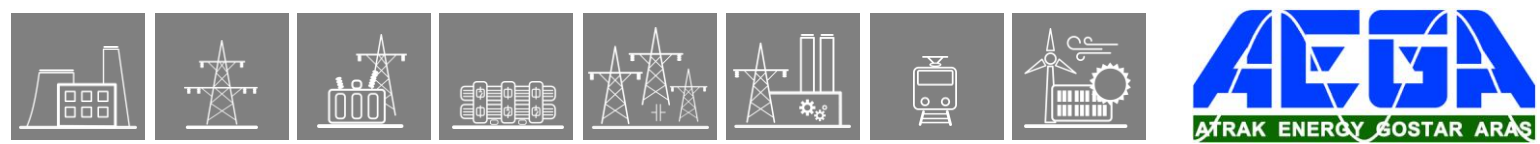

Figure 1-1 Principle of TRIP command processing



1.3.11.3.3. Application of TRIP relays for commands of fast protection functions

1.3.11.3.3.1. Aim of application of TRIP relays

The main aim of application of TRIP relays is to bypass the time delay of the mechanical contacts. For this aim there is a „slow” mechanical contact and a „fast” electronic switch in serial connection.

1.3.11.3.3.2. Control of the TRIP relays

The operation of the TRIP relays is performed in two steps:
Preparation of the circuit for the trip command
Trip command generation

1.3.11.3.3.2.1. Preparation of the circuit for the trip command

At the time when a protection function detects violation of the setting value of the characteristic quantity, the preparation process closes the „slow” mechanical contact, preparing the circuit for command generation.

1.3.11.3.3.2.2. The trip command generation

At the moment when the fast protection function – after some repeated checks, i.e. the timeout of the internal time counter – decides to generate the trip command then the „fast” electronic switch performs the operation, generating the trip command to the circuit breaker. This command is generated via the „TRC94_ PhS” or via the simplified „TRC94” trip logic functionblocks.

NOTE: If the TRIP command is not received within the expected time delay, then the command preparation resets after 50 ms. When the device is tested in the laboratory e.g. for measuring the limits of the distance protection characteristic, this can result a cyclic closing and opening of the mechanical contact and rattling can be heard. This does not mean faulty operation of the device!

1.3.11.3.3.3. The factory programming for relay control

For the trip command of protection functions, where the requirement is the fast operation (distance protection first zone, line differential protection, transformer differential protection, fast overcurrent stage, synchronous switching, etc.) the process of preparation and command generation is programmed in the form of „Fast logic”.

The alignment of the TRIP command is the task of the “TRIP logic functionblock”. All devices operating with TRIP binary output module, has a configured TRC 94 simplified, or a TRC 94_PhS TRIP logic functionblock. This converts e.g. the trip command due to phase-to-phase fault to a three-phase trip command, or extends the duration of the command according to the parameter setting. All these are described in the dedicated document.

The fast TRIP commands are assigned to the TRIP relay output contacts according to the factory configuration, but the user has a possibility to modify or extend this assignment using the EuroCAP configuration software. The factory assignment is described in the user manual of the given device configuration.

To ensure fast operation, this „Fast logic” is performed in each sampling cycle (1ms).

1.3.11.3.3.4. Changing the TRIP command assignment

The user has a possibility to modify or extend the TRIP command assignment using the EuroCAP configuration software. The menu item to be started is shown in *Figure 2-1*.

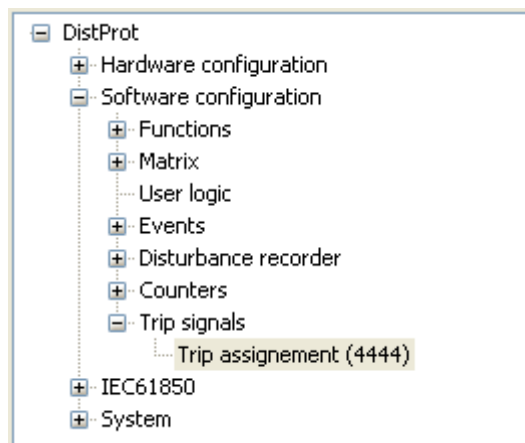

Figure 2-1 Menu item for TRIP command assignment

As *Figure 2-2* shows, the signal of type „TripLogic Output” (this is the command generated by the „TRIP logic functionblock”) can be assigned to a „Trip Contact” type relay output. The dialog window of the EuroCAP software selects these types of signals only; the available signals however can be assigned freely.

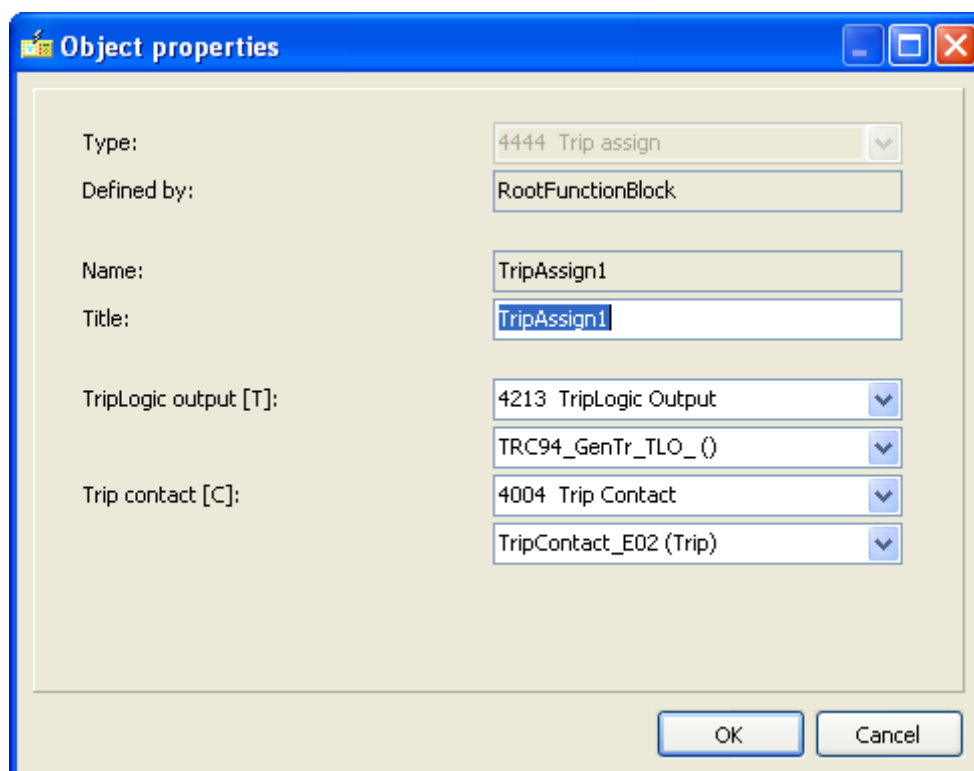
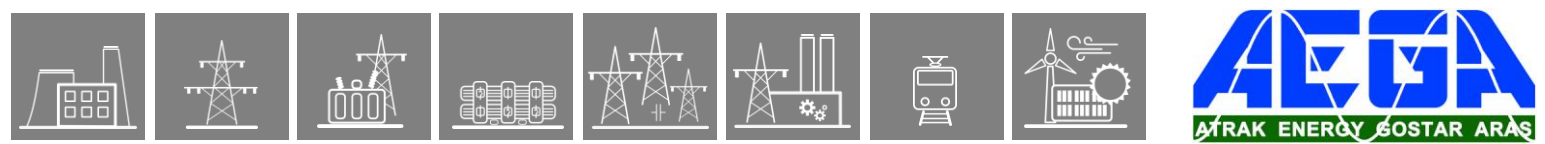

Figure 2-2 Changing the TRIP command assignment



The assigned signal is the input of an OR gate. As it is described below, several other signals can be directed to this OR gate. Using this method, also other TRIP modules extended by the user can be applied to operate the TRIP coil of the circuit breaker.

1.3.11.3.3.5. Fast operation of the relays

If the aim is to operate the contacts by a signal in each sampling cycle (1 ms), then the “Fast L1 contact option is to be applied. This option is provided by the EuroCAP configuration software in the menu „Hardware configuration/ IO signals/ Binary outputs/ Relay contacts/ Fast_L1 contacts”.

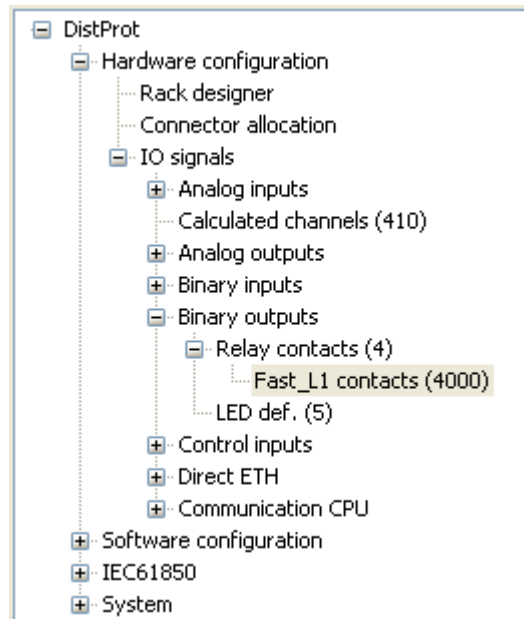

Figure 2-3 Configuring Fast L1 contacts

This menu offers the assignment of the appropriate binary signals to the relay contacts. As [Figure 2-4](#) shows, the signal can be of several types.

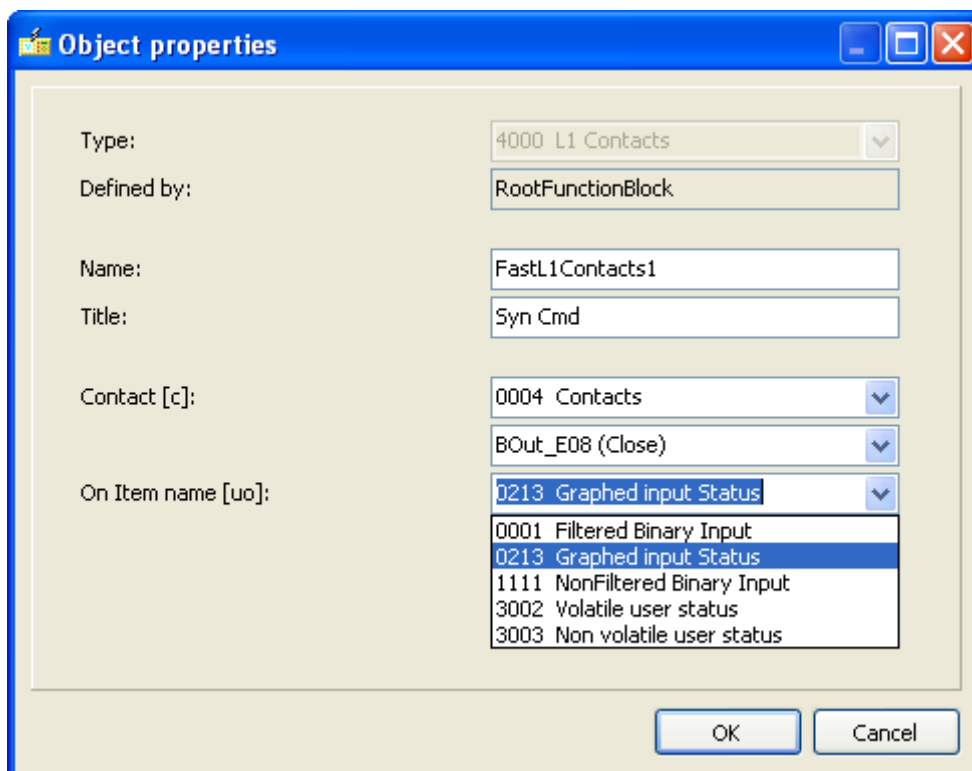

Figure 2-4 Fast L1 contact assignment

The processing of these fast signals is performed in a single step, the possibility for command preparation in the first step and additionally the TRIP command generation in the second step is not offered for the user. To perform this assignment, the application of the EuroCap configuration program in “Master” level is needed.

The selected signal is the input of an OR gate. To this gate additional other signals are connected, as it is described in the previous chapter, or in the description below.

IMPORTANT NOTE: The contacts of a TRIP hardware module are configured in the factory as “Fast L1 contacts”, the user does not need to define them additionally!

1.3.11.3.4. User application of the TRIP relays

The contacts controlling the circuit breaker operation can be programmed also by the user. Additionally to the command of the factory configured protection functions the user can assign signals to the channels of the TRIP hardware module. The two steps for the command generation however, as it is described in the paragraph above, cannot be applied by the user.

In this case, the source of the signals can be:

- Pre-configured TRIP commands
- Received from the SCADA system via communication channels,
- Generated by the user, applying the front panel LCD of the device,
- Any additional binary signals, e.g. an external command received by the binary input module of the device.

The pre-configured TRIP commands are aligned by the “CB control functionblock”, the output of which is the “CmdOff” TRIP command. This one and several other

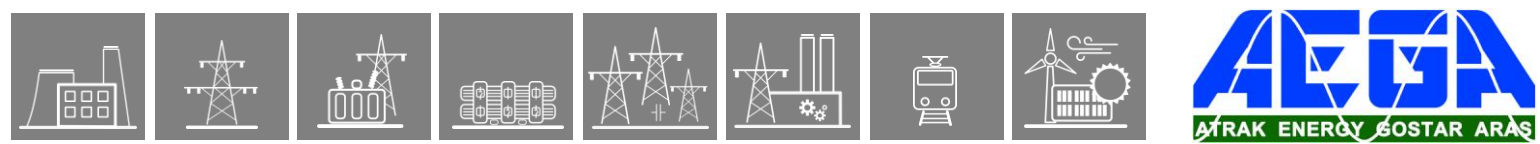

signals can be programmed by the user to the output TRIP contact of the device, using the graphic logic editor of the EuroCAP configuration software.

Additionally the output signals of the „TRC94_PhS” trip logic or those of the „TRC94” simplified trip logic block can be programmed here. (These function-blocks are described in separate documents.) The output signal of the graphic logic editor is the „BOut_X” logic variable, where X is the identifier of the relay module and the contact, e.g. BOut_E02.

1.3.11.3.4.1. Graphic editor for the signal logic

For the protection functions, the operation of which are not required being extreme fast (in the range of one network period), the trip command must be assigned to the trip contacts usually by the user. These logic assignments can be programmed also in the factory, but the user can modify or extend them according to the requirements. To do this, the graphic editor of the EuroCap configuration tool must be applied with „Master” access rights.

1.3.11.3.4.2. The process of command generation

If a “simple” protection function generates a trip command then this logic signal is present on the dedicated output of the functionblock (see the description of the functionblocks).

The operation of the logic connections edited in the graphic editor is performed outside the sampling cycle, consequently, depending on the actual load of the processor a random time delay of additional 2-4 ms can be measured.

The contacts of the TRIP hardware modules are operated by several sources parallel:

The high-speed factory configured fast protection functions,
The defined Fast L1 signals,
The graphically edited logic connections (programmed in the factory and editable also by the user).

1.3.11.3.5. Control of signal relay outputs

If there is no special requirement to generate the signal with high speed, i.e. a time delay of 2-4 ms can be tolerated between the intent to generate the signal and the closing of the output contact then it is sufficient to apply normal signal relay contacts. To perform this programming the graphic editor of the EuroCap configuration tool is to be applied. To perform the programming the „Master” access level is needed.

1.3.11.4. Examples

1.3.11.4.1. Application of the TRIP logic

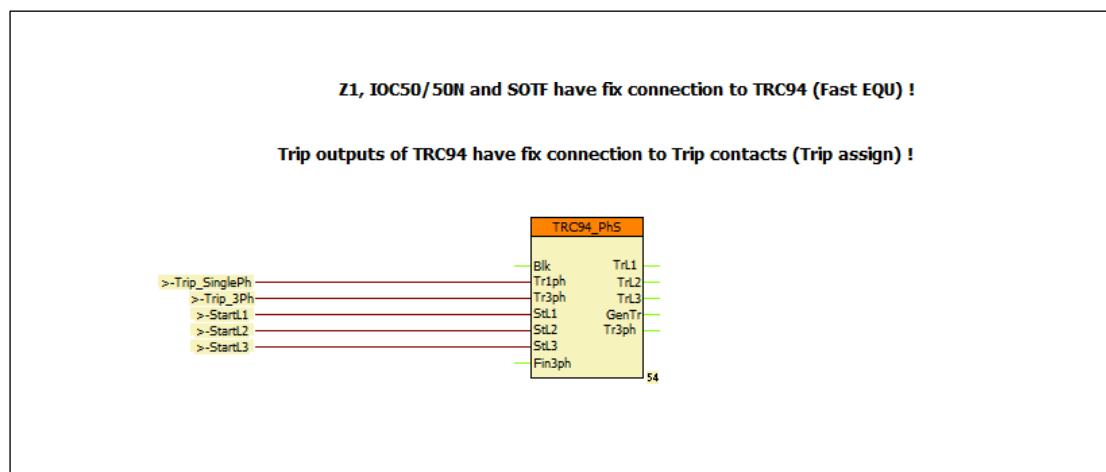

Figure 5-1 Example: A simple configuration to trip the circuit breaker

Figure 5-1 shows a simple configuration to trip the circuit breaker. In this Figure it is supposed that the fast protection functions operate according to the factory configuration and they control the TRIP contacts applying two steps of the preparation and command generation phases. This part of the program is not visible. (The description of the fast operating protection functions are listed in the configuration description of the devices.)

The outputs of the TRC94_PhS trip logic block are assigned to the channels of the TRIP hardware module. This assignment, which can be modified also by the user, is made not here but in the “TRIP assignment” menu of the EuroCAP configuration software. Consequently the Figure is complete; related to the outputs, the user needs additional graphic programming only if e.g. the operation is to be visualized also by signal relays.

If the configuration includes protection functions blocks the trip command of which does not need fast contact operation then these commands must be additionally directed to the TRIP relay outputs. To do this, the user collects these commands (with OR connection) and connects them to the dedicated inputs of the TRC94_PhS functionblock.

This Figure shows the collected signals (E.g. “Trip_SinglePh”, “Trip_3Ph”, etc.) only. As an example the „Trip_3Ph” signal collects the commands of all (not fast operating) protection functions which can generate three-phase trip command. The detailed description of the inputs and operation of the “TRC94_PhS” trip logic functionblock can be found in another document.

1.3.11.4.2. Application of circuit breaker control block

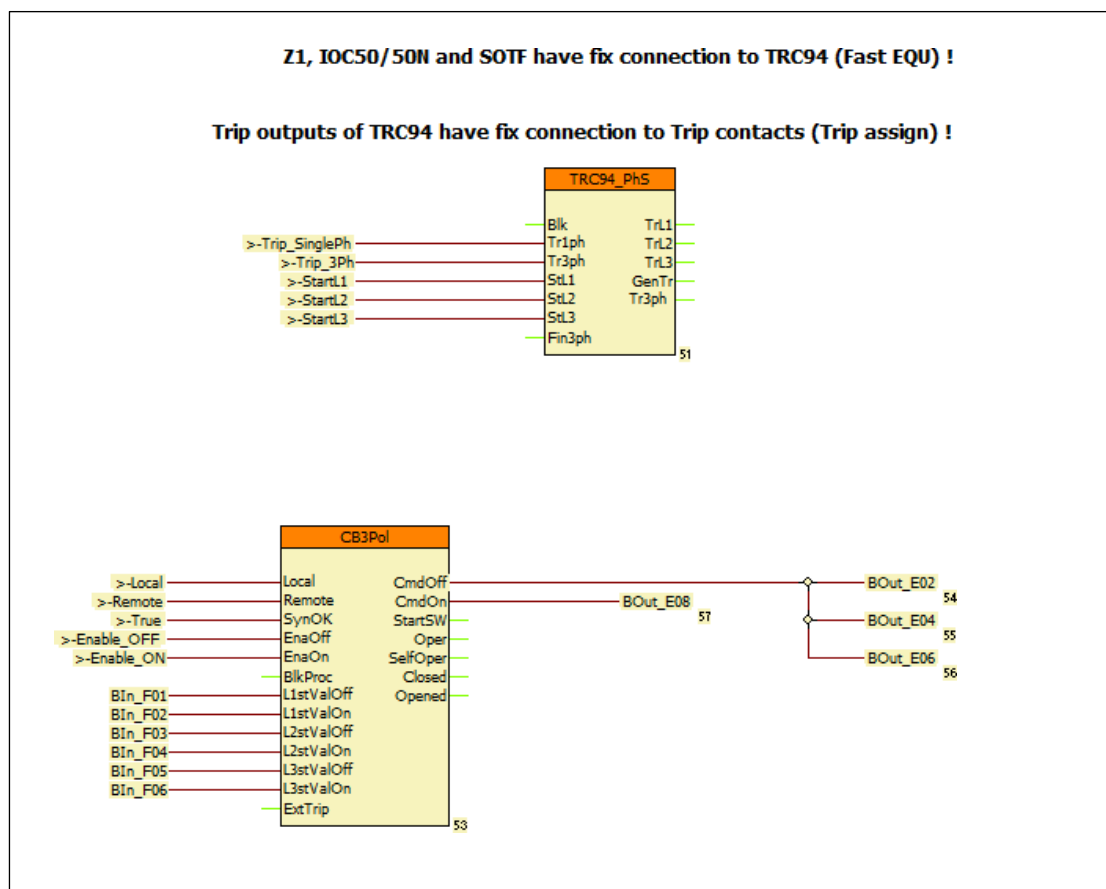

Figure 5-2 Example: Application of circuit breaker control block

Figure 5-2 shows an example for the application of the circuit breaker control block “CB3Pol”. In this Figure it is supposed that the fast protection functions operate according to the factory configuration and they control the TRIP contacts applying two steps of the preparation and command generation phases. This part of the program is not visible. (The description of the fast operating protection functions are listed in the configuration description of the devices.)

The outputs of the TRC94_PhS trip logic block are assigned to the channels of the TRIP hardware module. This assignment, which can be modified also by the user, is made not here but in the “TRIP assignment” menu of the EuroCAP configuration software. Consequently the Figure is complete; related to the outputs, the user needs additional graphic programming only if e.g. the operation is to be visualized also by signal relays.

If the configuration includes protection functions blocks the trip command of which does not need fast contact operation then these commands must be additionally connected to the TRIP relay outputs. To do this, the user collects these commands (with OR connection) and assigns them to the dedicated inputs of the TRC94_PhS functionblock.

This Figure shows the collected signals (E.g. “Trip_SinglePh”, “Trip_3Ph”, etc.) only. As an example the „Trip_3ph” signal collects the commands of all (not fast operating) protection functions which can generate three-phase trip command. The detailed description of the inputs and operation of the “TRC94_PhS” trip logic functionblock can be found in another document.

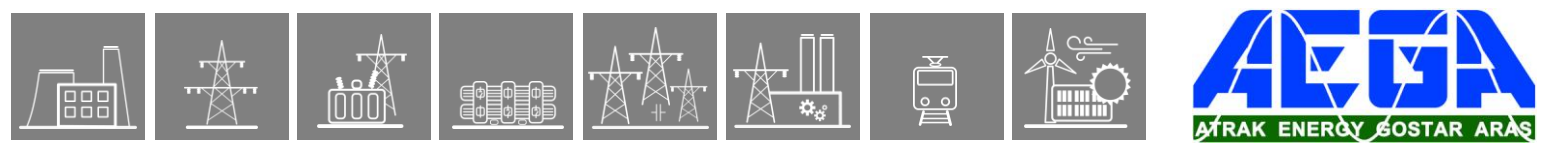

An extension to the example in *Figure 5-2* is that in this configuration also the „CB3pol” (circuit breaker control block) is applied. This block is needed if e.g. the front panel LCD of the device can display an active control scheme. For this purpose the signals „BIn_F...” in the Figure are the status signals of the circuit breaker poles, connected to the dedicated binary inputs of the device. The signals „Local”/”Remote” enable the local or remote control of the primary equipment. In the standard factory configurations these signals are programmed in the factory, but they can be modified also by the user.

If there is no synchro-check function activated in the device, connect the input „SynOK” of the “CB3Pol” to logic TRUE state. *Figure 5-2*, the local command issued via LCD of the device or the remote command received from the remote SCADA system is processed by the „CB3pol” functionblock (Output „CmdOff”). This control is programmed in the factory to “BOut_xx” variables. The user can perform any modification in the graphic programming.

The close command is connected directly to a dedicated “BOut_xx” variable. (This directs usually the fourth contact of the TRIP hardware module.)

The programming of the interlocking function must be performed by the user.

1.3.11.4.3. Automatic reclosing and circuit breaker control

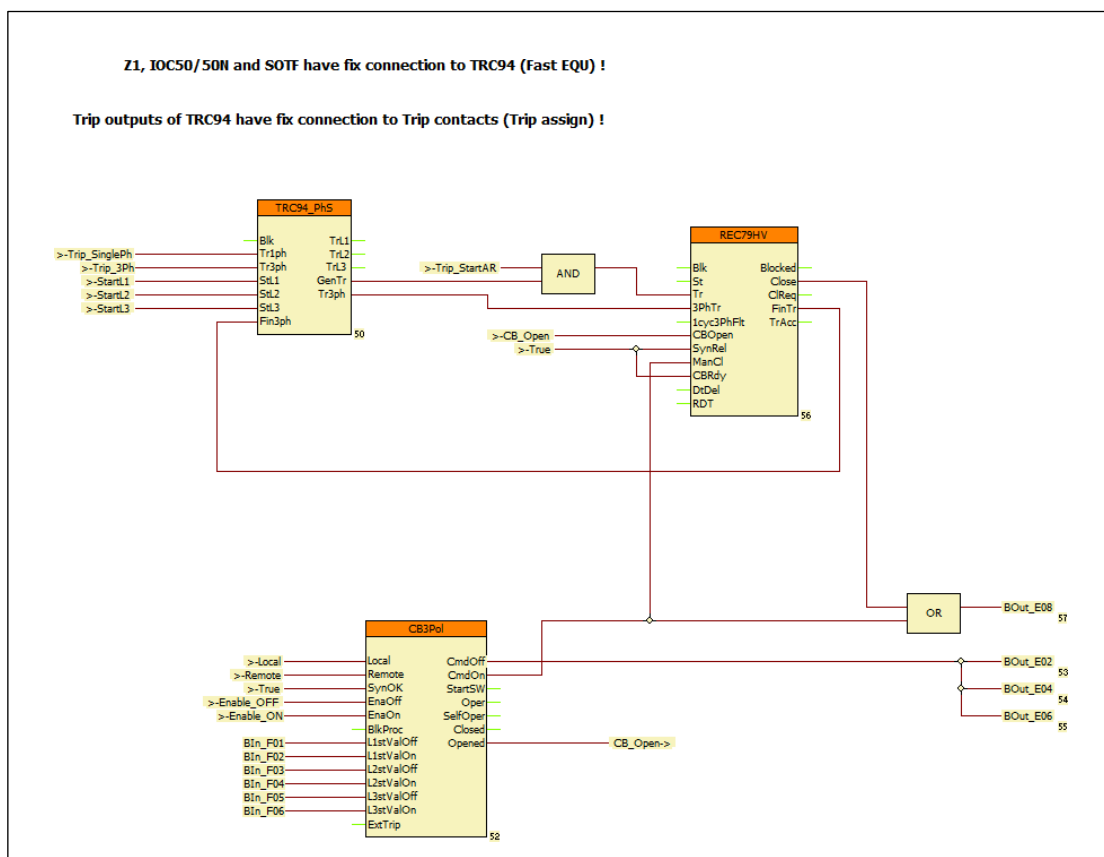

Figure 5-3 Example: Automatic reclosing and circuit breaker control

Figure 5-3 shows an example for the application of the automatic reclosing control block. In this Figure it is supposed that the fast protection functions operate according to the factory configuration and they control the TRIP contacts applying two steps of the preparation and command generation phases. This part of the program is not visible in “Master” level. (The description of the fast operating protection functions are listed in the configuration description of the devices.)

The outputs of the TRC94_PhS trip logic block are assigned to the output channels of the TRIP hardware module. This assignment, which can be modified also by the user, is made not here but in the “TRIP assignment” menu of the EuroCAP configuration software. Consequently the Figure is complete; related to the outputs, the user needs additional graphic programming only if e.g. the operation is to be visualized also by signal relays.

If the configuration includes protection functions blocks the trip command of which does not need fast contact operation then these commands must be additionally assigned to the TRIP relay outputs. To do this, the user collects these commands (with OR connection) and assigns them to the dedicated inputs of the TRC94_PhS functionblock.

This Figure shows the collected signals (E.g. “Trip_SinglePh”, “Trip_3Ph”, etc.) only. As an example the „Trip_3ph” signal collects the commands of all (not fast operating) protection functions which can generate three-phase trip command. The detailed description of the inputs and operation of the “TRC94_PhS” trip logic functionblock can be found in another document.

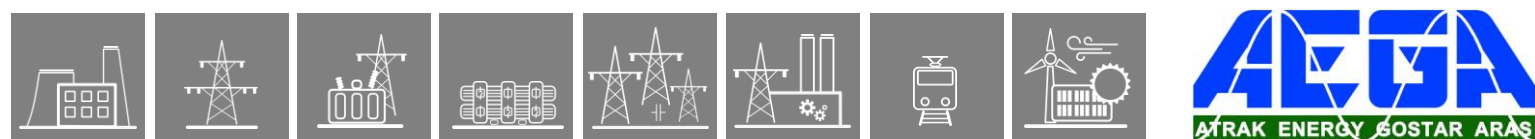

In this configuration also the „CB3pol” (circuit breaker control block) is applied. This block is needed if e.g. the front panel LCD of the device can display an active control scheme. For this purpose the signals „BIn_F...” in the Figure are the status signals of the circuit breaker poles, connected to the dedicated binary inputs of the device. The signals „Local”/”Remote” enable the local or remote control of the primary equipment. In the standard factory configurations these signals are programmed in the factory, but they can be modified also by the user.

If there is no synchro-check function activated in the device, connects the input „SynOK” of the “CB3Pol” to logic TRUE state.

According to *Figure 5-3*, the local command issued via LCD of the device or the remote command received from the remote SCADA system is processed by the „CB3pol” functionblock (Output „CmdOff”). This control is programmed in the factory to “BOut_xx” variables. The user can perform any modification in the graphic programming.

The close command is connected directly to a dedicated “BOut_xx” variable. (This directs usually the fourth contact of the TRIP hardware module.)

In *Figure 5-3* the close command is connected directly to a dedicated output. (This is usually the fourth contact of the TRIP hardware module.)

The programming of the interlocking function must be performed by the user.

An extension to the example in *Figure 5-2* is the application of the „REC79_HV” automatic reclosing function. The start signal „Trip_StartAR” can be programmed by the user. The automatic reclosing function is started only if the preceding trip command was performed by the circuit breaker, i.e. for example that the function is not disabled. The AND gate on this Figure performs this checking.

The „REC79_HV” automatic reclosing function needs the status signal indicating three-phase open state of the circuit breaker, connected to the „3PhTr” input of the „REC79_HV” functionblock. This signal is generated by the „TRC94_PhS” functionblock on the output „Tr3Ph”.

If the automatic reclosing is to be disabled after a fault caused by a manual close command, then the „CmdOn” output of the „CB3Pol” module must be connected to the „ManCl” input of the „REC79_HV” automatic reclosing function.

If there is no synchro-check function configured in the device, connect the „SynRel” input of the „REC79_HV” automatic reclosing function to logic TRUE state.

The evaluation of the status signals indicating the open state of the circuit breaker poles in OR gate is needed for the operation of the automatic reclosing function. According to the scheme of *Figure 5-3* the open state is indicated by at least one pole open state of the circuit breaker. (For simplicity, this Figure shows a realization without checking the FALSE signal of the closed states.)

Figure 5-3 supposes that the CB ready signal is not connected to the device; accordingly the steady TRUE state signal is connected to the „CBRdy” input of the „REC79_HV” automatic reclosing function. If the real signal is available, the signal must be connected similarly.

The close command of the „REC79_HV” automatic reclosing function is connected via OR gate to the dedicated close contact.

1.3.11.4.4. Closing the circuit breaker with synchro-check

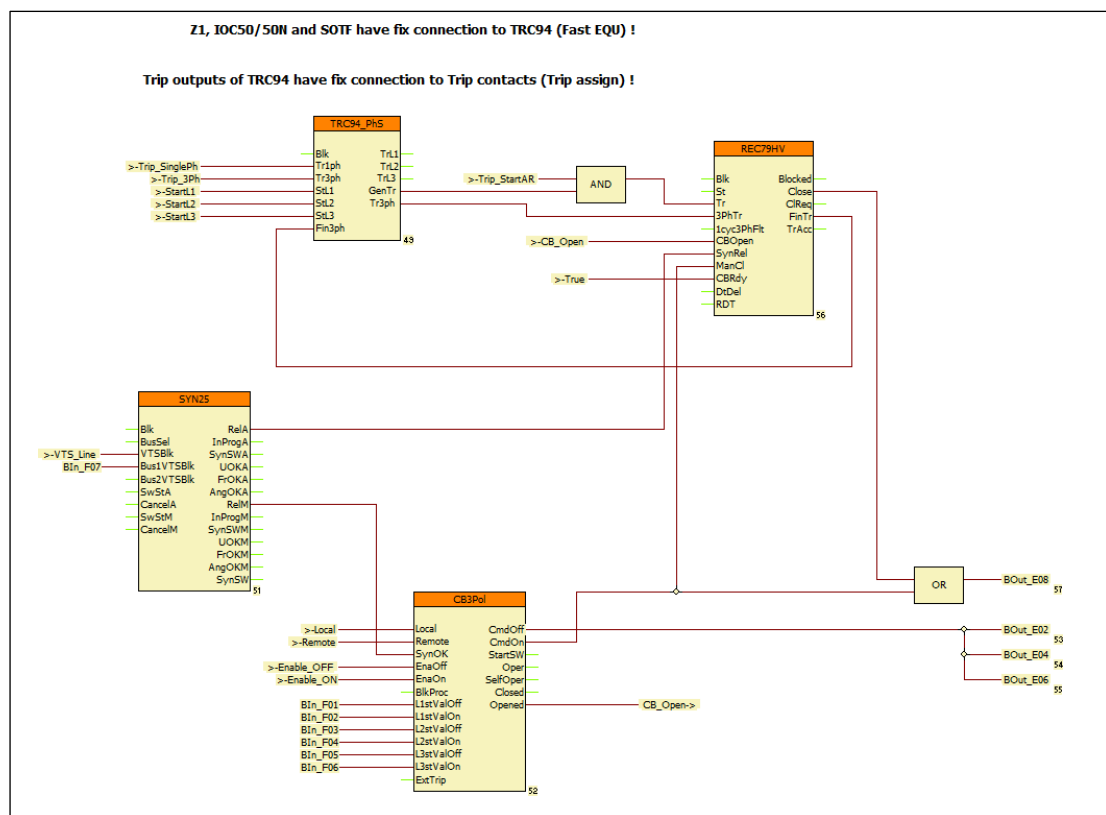

Figure 5-4 Example: closing the circuit breaker with synchro-check

Figure 5-4 shows an example for the application of “SYN25” synchro-check functionblock. In this Figure it is supposed that the fast protection functions operate according to the factory configuration and they control the TRIP contacts applying two steps of the preparation and command generation phases. This part of the program is not visible in “Master” level. (The description of the fast operating protection functions are listed in the configuration description of the devices.)

The outputs of the TRC94_PhS trip logic block are assigned to the output channels of the TRIP hardware module. This assignment, which can be modified also by the user, is made not here but in the “TRIP assignment” menu of the EuroCAP configuration software. Consequently the Figure is complete; related to the outputs, the user needs additional graphic programming only if e.g. the operation is to be visualized also by signal relays.

If the configuration includes protection functions blocks the trip command of which does not need fast contact operation then these commands must be additionally assigned to the TRIP relay outputs. To do this, the user collects these commands (with OR connection) and assigns them to the dedicated inputs of the TRC94_PhS functionblock.

This Figure shows the collected signals (E.g. “Trip_SinglePh”, “Trip_3Ph”, etc.) only. As an example the „Trip_3ph” signal collects the commands of all (not fast operating) protection functions which can generate three-phase trip command. The detailed description of the inputs and operation of the “TRC94_PhS” trip logic functionblock can be found in another document.

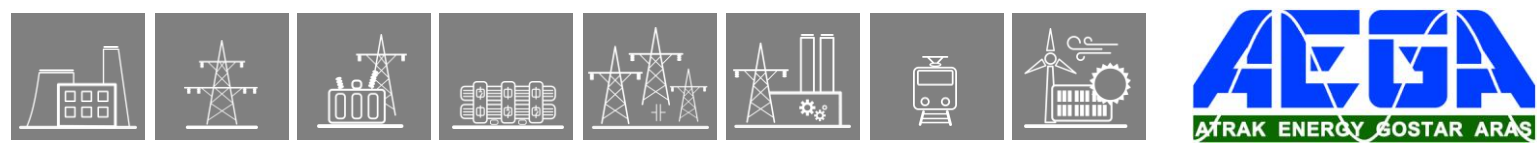

In this configuration also the „CB3pol” (circuit breaker control block) is applied. This block is needed if e.g. the front panel LCD of the device can display an active control scheme. For this purpose the signals „BIn_F...” in the Figure are the status signals of the circuit breaker poles, connected to the dedicated binary inputs of the device. The signals „Local”/”Remote” enable the local or remote control of the primary equipment. In the standard factory configurations these signals are programmed in the factory, but they can be modified also by the user.

According to *Figure 5-4*, the local command issued via LCD of the device or the remote command received from the remote SCADA system is processed by the „CB3pol” functionblock (Output „CmdOff”). This control is programmed in the factory to “BOut_xx” variables. The user can perform any modification in the graphic programming.

The close command is connected directly to a dedicated “BOut_xx” variable. (This directs usually the fourth contact of the TRIP hardware module.)

In *Figure 5-4* the close command is connected directly to a dedicated output. (This is usually the fourth contact of the TRIP hardware module.)

The programming of the interlocking function must be performed by the user.

Figure 5-4 includes the application of the „REC79_HV” automatic reclosing function. The start signal „Trip_StartAR” can be programmed by the user. The automatic reclosing function is started only if the preceding trip command was performed by the circuit breaker, i.e. for example that the function is not disabled. The AND gate on this Figure performs this checking.

The „REC79_HV” automatic reclosing function needs the status signal indicating three-phase open state of the circuit breaker, connected to the „3PhTr” input of the „REC79_HV” functionblock. This signal is generated by the „TRC94_PhS” functionblock on the output „Tr3Ph”.

If the automatic reclosing is to be disabled after a fault caused by a manual close command, then the „CmdOn” output of the „CB3Pol” module must be connected to the „ManCl” input of the „REC79_HV” automatic reclosing function.

The evaluation of the status signals indicating the open state of the circuit breaker poles in OR gate is needed for the operation of the automatic reclosing function. According to the scheme of *Figure 5-4* the open state is indicated by at least one pole open state of the circuit breaker. (For simplicity, this Figure shows a realization without checking the FALSE signal of the closed states.)

Figure 5-4 supposes that the CB ready signal is not connected to the device; accordingly the steady TRUE state signal is connected to the „CBRdy” input of the „REC79_HV” automatic reclosing function. If the real signal is available, the signal must be connected similarly.

The close command of the „REC79_HV” automatic reclosing function is connected via OR gate to the dedicated close contact.

An extension to the example in *Figure 5-3* is the close command to the circuit breaker is generated by synchro-check. The enabling signal for the close command is generated by the „SYN25” software module. This module is described in details in a separate document. The needed input signals indicating the state of the voltage transformers („VTSBik” and „Bus1VTSBik”), must be programmed graphically.

The output signal „RelA” of the „SYN25” software module enables the closing operation of the „REC79_HV” automatic reclosing function via its „SynRel” input.

For manual close commands the output signal „RelM” of the „SYN25” software module enables the closing operation of the „CB3pol” via its „SynOK” input.

1.3.11.4.5. Closing the circuit breaker with synchro-check and synchro-switch

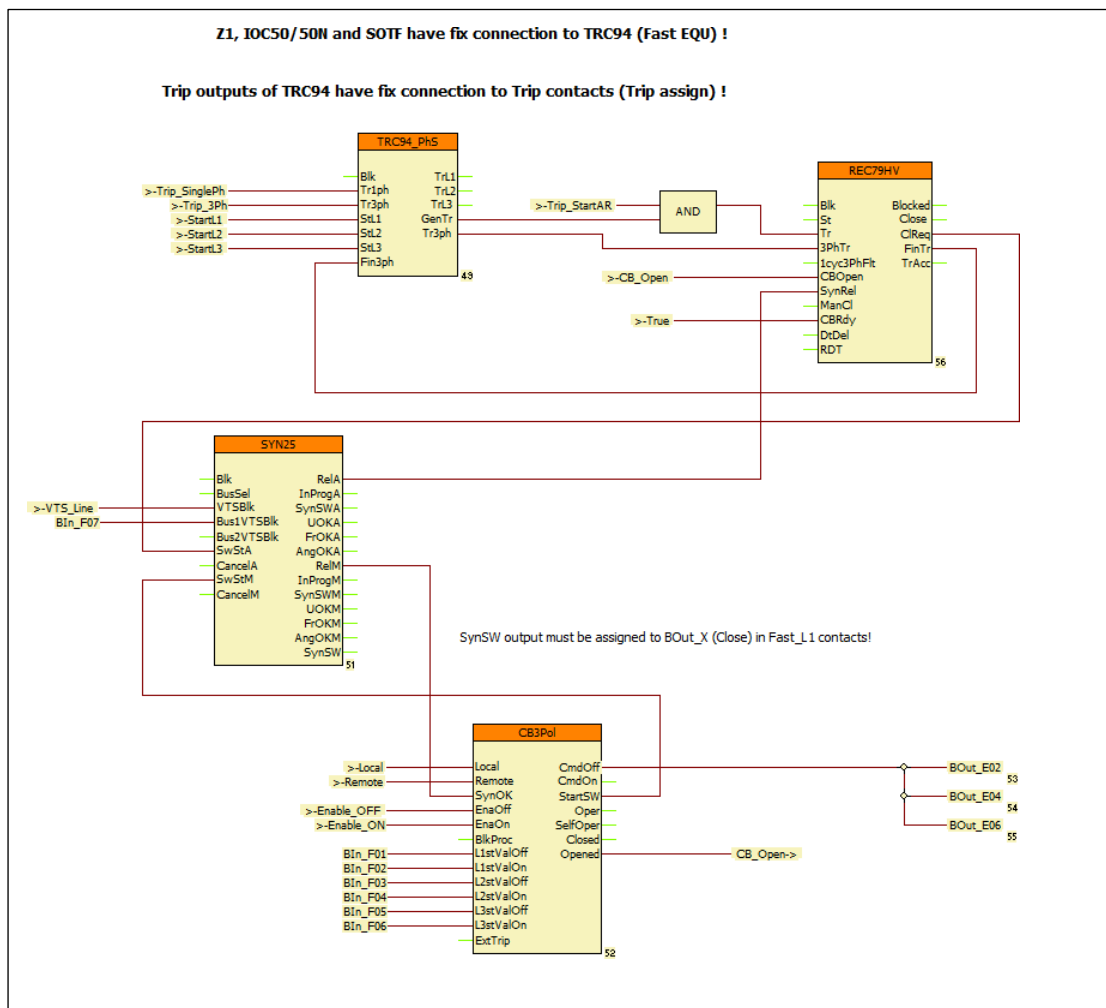
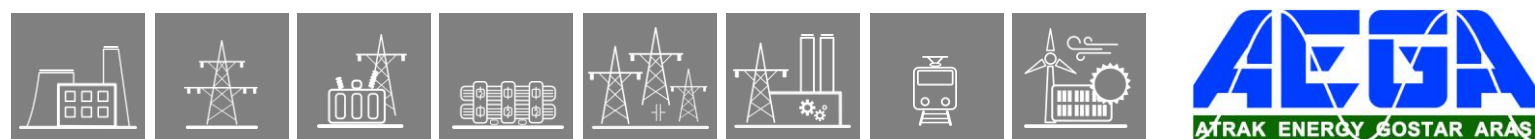

Figure 5-5 Example: closing the circuit breaker with synchro-check and synchro-switch

Figure 5-5 shows an example for the application of “SYN25” synchro-check function block with synchro switch extension. In this Figure it is supposed that the fast protection functions operate according to the factory configuration and they control the TRIP contacts applying two steps of the preparation and command generation phases. This part of the program is not visible in “Master” level. (The description of the fast operating protection functions are listed in the configuration description of the devices.)

The outputs of the TRC94_PhS trip logic block are assigned to the output channels of the TRIP hardware module. This assignment, which can be modified also by the user, is made not here but in the “TRIP assignment” menu of the EuroCAP configuration software. Consequently the Figure is complete; related to the outputs, the user needs additional graphic programming only if e.g. the operation is to be visualized also by signal relays.

If the configuration includes protection functions blocks the trip command of which does not need fast contact operation then these commands must be additionally assigned to the TRIP relay outputs. To do this, the user collects these commands



(with OR connection) and assigns them to the dedicated inputs of the TRC94_PhS functionblock.

This Figure shows the collected signals (E.g. „Trip_SinglePh”, „Trip_3Ph”, etc.) only. As an example the „Trip_3ph” signal collects the commands of all (not fast operating) protection functions which can generate three-phase trip command. The detailed description of the inputs and operation of the “TRC94_PhS” trip logic functionblock can be found in another document.

In this configuration also the „CB3pol” (circuit breaker control block) is applied. This block is needed if e.g. the front panel LCD of the device can display an active control scheme. For this purpose the signals „BIn_F...” in the Figure are the status signals of the circuit breaker poles, connected to the dedicated binary inputs of the device. The signals „Local”/„Remote” enable the local or remote control of the primary equipment. In the standard factory configurations these signals are programmed in the factory, but they can be modified also by the user.

According to *Figure 5-5*, the local command issued via LCD of the device or the remote command received from the remote SCADA system is processed by the „CB3pol” functionblock (Output „CmdOff”). This control is programmed in the factory to “BOut_xx” variables. The user can perform any modification in the graphic programming.

The close command is connected directly to a dedicated “BOut_xx” variable. (This directs usually the fourth contact of the TRIP hardware module.)

In *Figure 5-5* the close command is connected directly to a dedicated output. (This is usually the fourth contact of the TRIP hardware module.)

The programming of the interlocking function must be performed by the user.

Figure 5-5 includes the application of the „REC79_HV” automatic reclosing function. The start signal „Trip_StartAR” can be programmed by the user. The automatic reclosing function is started only if the preceding trip command was performed by the circuit breaker, i.e. for example that the function is not disabled. The AND gate on this Figure performs this checking.

The „REC79_HV” automatic reclosing function needs the status signal indicating three-phase open state of the circuit breaker, connected to the „3PhTr” input of the „REC79_HV” functionblock. This signal is generated by the „TRC94_PhS” functionblock on the output „Tr3Ph”.

If the automatic reclosing is to be disabled after a fault caused by a manual close command, then the „CmdOn” output of the „CB3Pol” module must be connected to the „ManCl” input of the „REC79_HV” automatic reclosing function.

If there is no synchro-check function configured in the device, then connect the „SynRel” input of the „REC79_HV” automatic reclosing function to logic TRUE state.

The evaluation of the status signals indicating the open state of the circuit breaker poles in OR gate is needed for the operation of the automatic reclosing function. According to the scheme of *Figure 5-5* the open state is indicated by at least one pole open state of the circuit breaker. (For simplicity, this Figure shows a realization without checking the FALSE signal of the closed states.)

Figure 5-5 supposes that the CB ready signal is not connected to the device; accordingly the steady TRUE state signal is connected to the „CBRdy” input of the „REC79_HV” automatic reclosing function. If the real signal is available, the signal must be connected similarly.

The close command of the „REC79_HV” automatic reclosing function is connected via OR gate to the dedicated close contact.

In this application the close command to the circuit breaker is generated by synchro-check. The enabling signal for the close command is generated by the „SYN25” software module. This module is described in details in a separate document. The



needed input signals indicating the state of the voltage transformers („VTSBik” and „Bus1VTSBik”), must be programmed graphically.

The output signal „RelA” of the „SYN25” software module enables the closing operation of the „REC79_HV” automatic reclosing function via its „SynRel” input.

For manual close commands the output signal „RelM” of the „SYN25” software module enables the closing operation of the „CB3pol” via its „SynOK” input.

An extension to the example in *Figure 5-4* is the following: If there is no continuous synchron state because the frequency at one side of the circuit breaker is different to that of the other side, then the voltage vector of one side rotates continuously as compared to the other one. In this case a synchronous switching is attempted to restore the normal operation of the network.

The manual synchron switching mode is started by the signal on the „StSwM” input of the SYN25 functionblock. To do this the the „StartSW” output of the „CB3Pol” functionblock must be connected here.

For automatic synchron switching mode the „CIReq” output of the „Rec79HV” module must be connected to the „SwStA” input of the „SYN25” software module.

IMPORTANT NOTE: the close command is generated for both manual and automatic

switching at the output „SynSW” of the „SYN25” software module. It is advised not to connect this output using the „slow” graphic programming, but the contact assigned to the close command („BOutClose”) must be handled as fast operating „L1 contact”. The „SynSW” signal must be programmed to this contact. This assignment is performed using the EuroCap configuration tool in the menu „Hardware configuration/Binary outputs/Relay contacts/Fast_L1 contacts”.

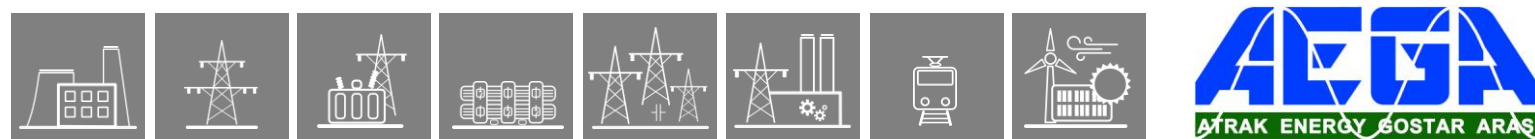

1.3.12. RTD input module

The RTD+1100 module is used to measure the temperature through the variation of resistance of temperature detectors. RTD+0200 and RTD+1200 are special modules for Petersen coil controllers (DRL) measuring the resistance of the potentiometer.

Connector types:

- The default and optionally available connector types are indicated for each module in the table below. See Chapter 20.2 for details about each type.

MODULE TYPE	RTD+/0200*	RTD+/1100	RTD+/1200*
CHANNEL NUMBER	1	4	1
MEASUREMENT METHOD	3 wire configuration	2, 3 or 4 wire configuration	3 wire configuration
ACCURACY	± 0.5 % ± 1 digit	± 0.5 % ± 1 digit	± 0.5 % ± 1 digit
SENSOR TYPE	Service-Ohm	Pt100/Ni100 Ni120/Ni120US Pt250/Ni250 Pt1000/Ni1000 Cu10 Service-Ohm (60 Ω ... 1.6 kΩ)	Service-Ohm
MEASUREMENT RANGES	2 Ω ... 200 Ω	- 50 °C – +150 °C	10 Ω ... 1000 Ω
CONNECTOR TYPE	Default: BLA Options: -	Default: BLA Options: T	Default: BLA Options: -
RECOMMENDED APPLICATION	Arc suppression coil controller	General resistance-based temperature measurement	Arc suppression coil controller

*Special module

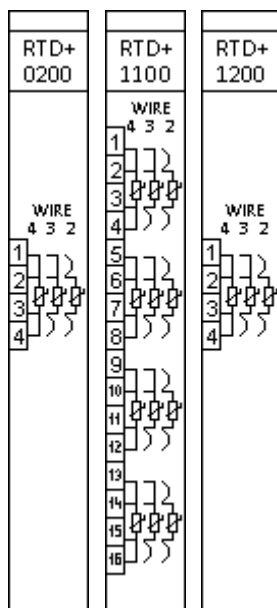

Figure 10-1 RTD input modules

1.3.12.1. RTD module wiring

If 2-wire wiring is used you have to make sure that the value of R_A and R_D resistors are set correctly in the “parameters” menu of the web server.

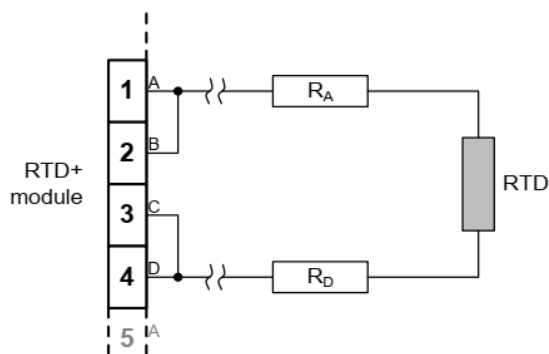

Figure 10-2 2-wire RTD wiring

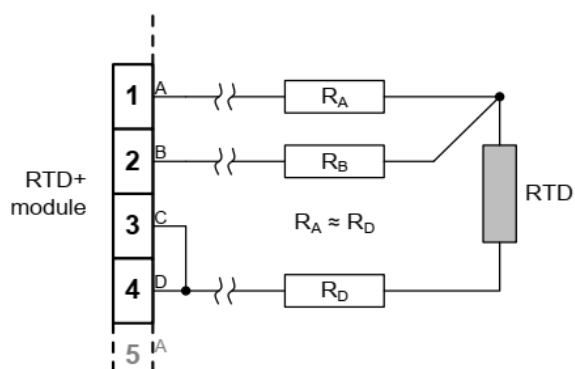

Figure 10-3 3-wire RTD wiring

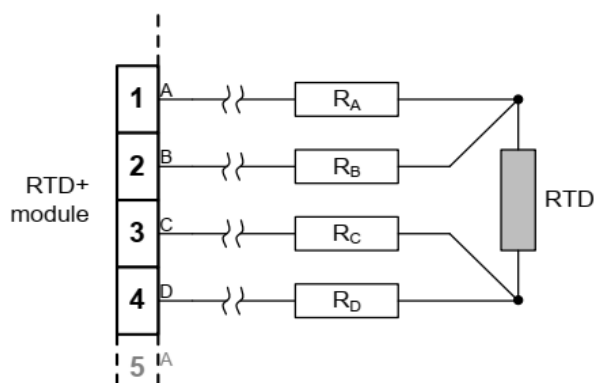

Figure 10-4 4-wire RTD wiring

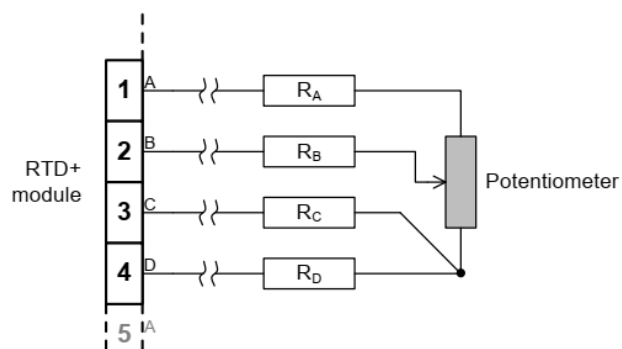

Figure 10-5 4-wire RTD wiring of potentiometer

1.3.13. Analog input module (AI)

The analog input module accepts transducers' current outputs. The AIC module can measure unipolar and bipolar current values in wide ranges.

Connector types:

- The default and optionally available connector types are indicated for each module in the table below. See Chapter 20.2 for details about each type.

MODULE TYPE	AIC+/0200*	AIC+/0201*	AIC+/0202
CHANNEL NUMBER	4	4	4
MEASUREMENT METHOD	2 wire inputs	2 wire inputs with optional 12 V excitation	2 wire inputs
RELATIVE ACCURACY	$\pm 0.5 \% \pm 1$ digit	$\pm 0.5 \% \pm 1$ digit	$\pm 0.5 \% \pm 1$ digit
MEASUREMENT RANGES	± 20 mA (typical 0-20, 4-20 mA) $R_{LOAD} = 56 \Omega$	± 20 mA (typical 0-20, 4-20 mA) $R_{LOAD} = 56 \Omega$	± 20 mA (typical 0-20, 4-20 mA) $R_{LOAD} = 56 \Omega$
CONNECTOR TYPE	<u>Default:</u> BLA <u>Options:</u> -	<u>Default:</u> BLA <u>Options:</u> -	<u>Default:</u> BLA <u>Options:</u> F, T

***Obsolete module. These modules are not recommended for new designs!**

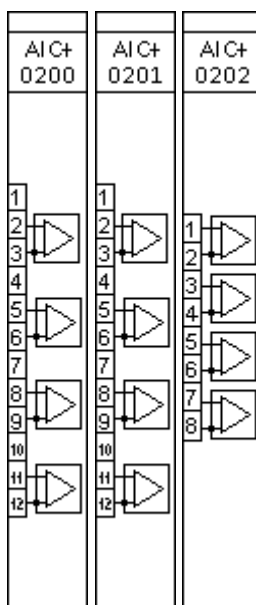
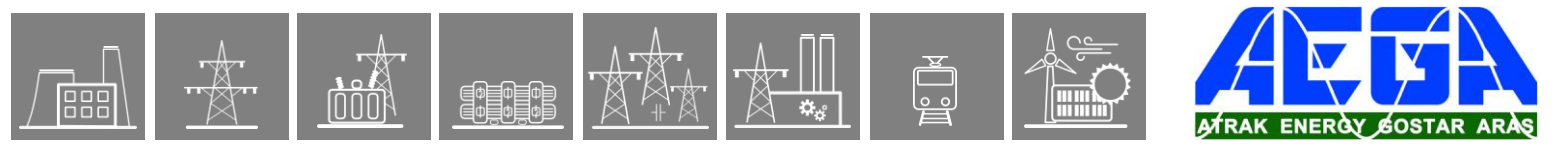

Figure 11-1 Analog input modules



1.3.13.1. AI module wiring

The following wiring method can be applied.

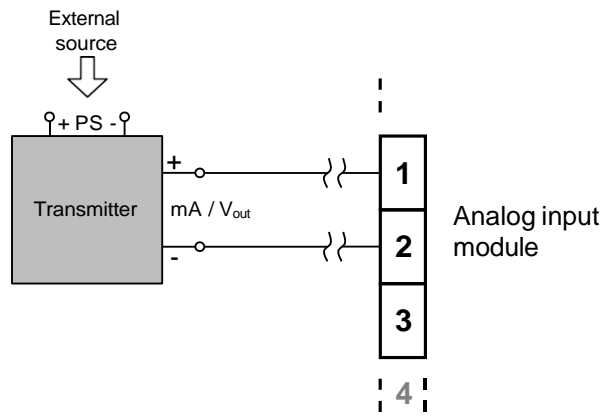

Figure 11-2 AI wiring

1.3.14. Analog output module (ATO)

The analog output module transmits current or voltage signals. The ATO module can be used in wide ranges in unipolar and bipolar mode.

Connector types:

- The default and optionally available connector types are indicated for each module in the table below. See Chapter 20.2 for details about each type.

MODULE TYPE	ATO+/0002	ATO+/0004
CHANNEL NUMBER	2	4
OUTPUT MODE	2 wire output	2 wire output
MAXIMUM LOAD ($R_{\text{CABLE}} + R_{\text{RECEIVER}}$)	500 Ω	500 Ω
OUTPUT RANGES	± 20 mA 0 - 20 mA 4 - 20 mA	± 20 mA 0 - 20 mA 4 - 20 mA
CONNECTOR TYPE	Default: BLA Options: T	Default: BLA Options: -

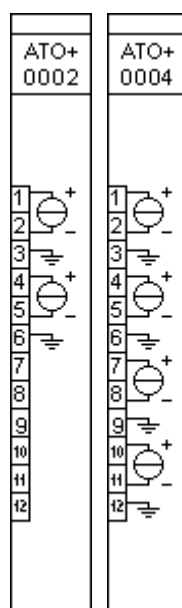

Figure 12-1 Analog output modules

1.3.14.1. ATO module wiring

The analog output module should be connected according to the following wiring diagram.

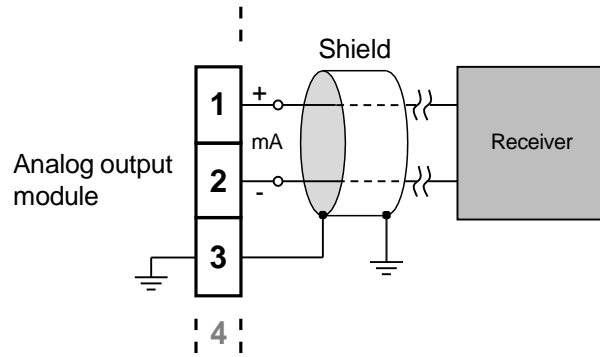

Figure 12-2 Analog output module wiring diagram

1.3.15. Sensor input module

The sensor modules receive low-level signals of current and voltage sensors (low-power instrument transformers).

Connector types:

- The default and optionally available connector types are indicated for each module in the table below. See Chapter 20.2 for details about each type.

MODULE TYPE	CVS+/0001		CVSR+/0001		VS+/0031***
CHANNEL NUMBER	4 U	4 I	4 U	4 I	4 U
NOMINAL VALUES	3.25 V	0.225 V*	1.27 V	0.150 V**	3.25 V
CONTINUOUS VOLTAGE WITHSTAND	35 V DC		35 V DC		35 V DC
SHORT TIME OVERLOAD (1 s)	40 V AC / 56 V DC		40 V AC / 56 V DC		40 V AC / 56 V DC
MAX. MEASURED VALUE ($\pm 10\%$)	1.8 U _N	50 I _N	2.1 U _N	50 I _N	1.6 U _N
ACCURACY	$\leq 0.5\%$ (0.1 U _N – 1.2 U _N)		$\leq 0.5\%$ (0.1 U _N – 1.2 U _N)		$\leq 0.5\%$ (0.1 U _N – 1.2 U _N)
FREQUENCY RANGE	DC – 1 kHz		DC – 1 kHz		DC – 1 kHz
INPUT RESISTANCE	200 k Ω $\pm 1\%$	21 k Ω $\pm 1\%$	10 M Ω $\pm 1\%$	1.1 M Ω $\pm 1\%$	200 k Ω $\pm 1\%$
INPUT CAPACITANCE	300 pF (1 kHz)	300 pF (1 kHz)	300 pF (1 kHz)	300 pF (1 kHz)	300 pF (1 kHz)
CONNECTOR TYPE	RJ45 – 8 pole, shielded connector, isolated shielding		RJ45 – 8 pole, shielded connector, grounded shielding		M8 3-pin connector Receptacle: Hirschmann ELST 3308 RV FM 8 05 Plug: Binder 768 99-3360-00-03

*Voltage proportional to current

**Voltage proportional to current change (Rogowski coil)

*****Obsolete module. These modules are not recommended for new designs!**

For more information about more available nominal values please contact our Application Team. (application@protecta.hu)

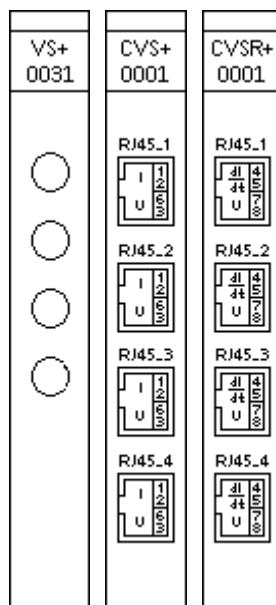
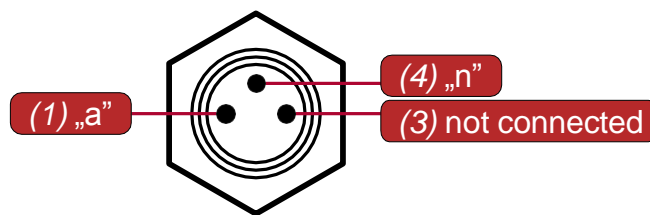
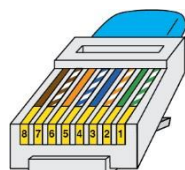

Figure 13-1 Voltage sensor modules



(FRONT VIEW)

Figure 13-2 M8 connector pinout



- 1.: S1
- 2.: S2
- 3.: "a"
- 6.: "n"

Figure 13-3 CVS module connector pinout



- 4.: S1
- 5.: S2
- 8.: "n"
- 7.: "a"

Figure 13-4 CVSR module connector pinout

1.3.16. INJ module

Complex module for controlling the Petersen coil, which contains an injector function for the measurements, an enabling and a blocking input, and a fault relay indicating if there is any fault in the injection circuit.

Connector types:

- The default and optionally available connector types are indicated for each module in the table below. See Chapter 20.2 for details about each type.

MODULE TYPE	INJ+/0005	INJ+/0015*
INJECTED CURRENT	2 A	4 A
ENABLING INPUT CLAMP VOLTAGE	85 V AC	Not available function
BLOCKING INPUT CLAMP VOLTAGE	200 V AC	200 V AC
ADDITIONAL RESISTANCE FOR VOLTAGE INPUT	Not available function	265 kΩ ± 1%
CONNECTOR TYPE	Default: STVS6, BLA10 Options: -	
RECOMMENDED APPLICATION	Arc suppression coil controller	Network compensation level measurement on resonant grounded networks

*Special module

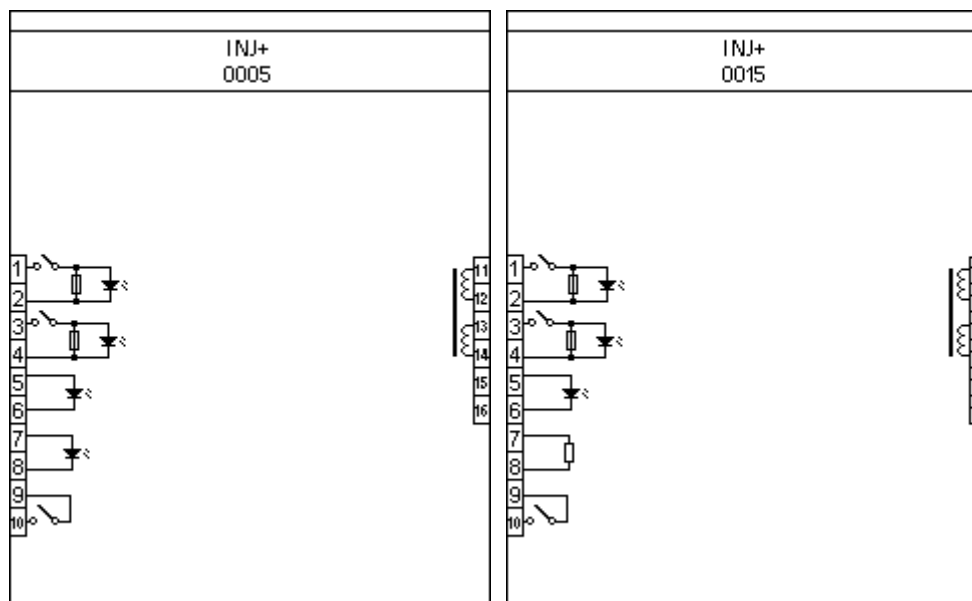

Figure 14-1 INJ modules

1.3.17. Generator protection modules

Special generator protection modules whose system measures and produces the necessary analog signals.

Connector types:

- The default and optionally available connector types are indicated for each module in the tables below. See Chapter 20.2 for details about each type.

MODULE TYPE	RAI+/01	RAI+/11	RINJ+/21
NOMINAL VOLTAGE	-	-	110 V / 220 V
INPUT VOLTAGE RANGE	-	-	88 - 264 V DC 80 - 250 V AC
OUTPUT VOLTAGE	-	-	100V DC \pm 2 %
MEASUREMENT RANGE	\pm 20 mA	\pm 20 mA	-
THERMAL WITHSTAND CONTINUOUS: 30 SEC:	15 mA 20 mA	10 mA 20 mA	20 mA
CONNECTOR TYPE	<u>Default:</u> STVS8 <u>Options:</u> -	<u>Default:</u> STVS8 <u>Options:</u> T*	<u>Default:</u> STVS8 <u>Options:</u> T*
RECOMMENDED APPLICATION	Rotor earth-fault protection of middle-grounded rotors	Rotor earth-fault protection of ungrounded (isolated) rotors	Rotor earth-fault protection of ungrounded (isolated) rotors

*By choosing this option, the connector remains the same, only the handle is changed

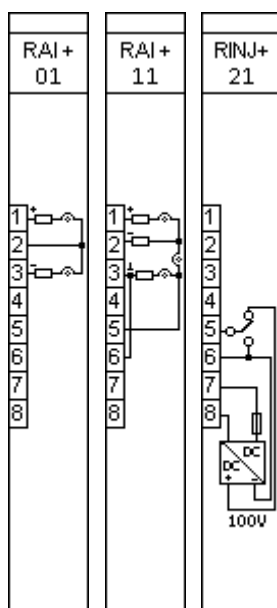

Figure 15-1 Generator protection modules

1.3.17.1. Auxiliary boxes for rotor earth fault protection

These DIN-rail mounted external boxes serve as couplings between the rotor (exciter circuit) of the generator and the corresponding RAI module of the protection device.

Note: the data about the resistances and capacitors provided here does not tell the actual time constants of the measured values, as those can be determined on-site only, when the rotor earth fault protection is being tested on the actual generator itself.

MODULE TYPE	RAI+01 BOX	RAI+11 BOX BASE	RAI+11 BOX EXTENSION*
MAXIMUM INPUT VOLTAGE	200 V, 300 V, 400 V, 500 V**	600 V	1200 V
SERIES RESISTANCE ON SIDES	10 k Ω , 15 k Ω , 20 k Ω , 25 k Ω **	35 k Ω	30 k Ω
FILTER CAPACITORS	4x10 μ F	2x1 μ F	-
CONNECTOR TYPE	Default: STVS6 Options: -	Default: STVS6 Options: -	Default: STVS6 Options: -
RECOMMENDED APPLICATION	Middle-grounded rotors	Ungrounded (isolated) rotors	Ungrounded (isolated) rotors

*This extension module can only be used together with RAI+11 BOX BASE module

**According to the chosen wiring

1.3.17.1.1. Use of auxiliary boxes

- **Ungrounded (isolated) rotors:**

If the excitation voltage is lower than 600 V, then it is enough to use the RAI+11 BOX BASE auxiliary box. If the excitation voltage is higher than 600 V, the RAI+11 BOX EXTENSION auxiliary box shall be used *additionally*, so the protection can connect to up to 1200 V excitation voltage.

- **Middle-grounded rotors**

Front drawings near the connectors on the box itself indicate the available maximum voltages. The choice from these shall be made according to the excitation voltage. Wiring shall be done according to the chosen voltage.

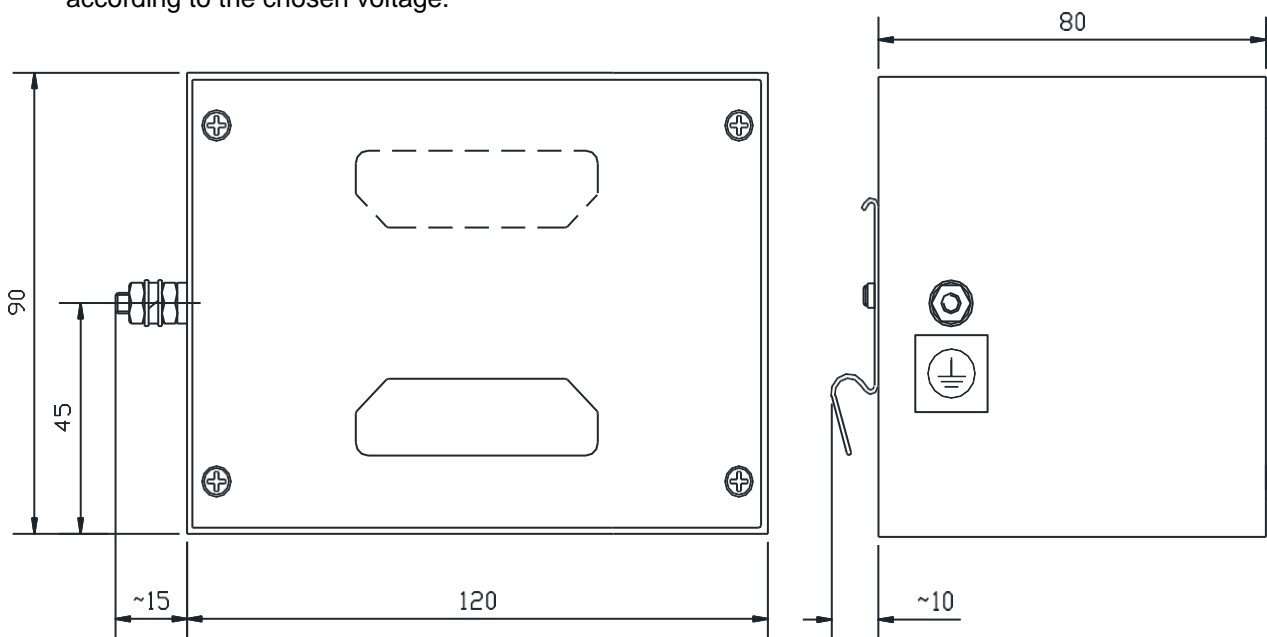

Figure 15-2 Size of the auxiliary boxes

1.3.17.2. Wiring of the rotor earth fault protection modules

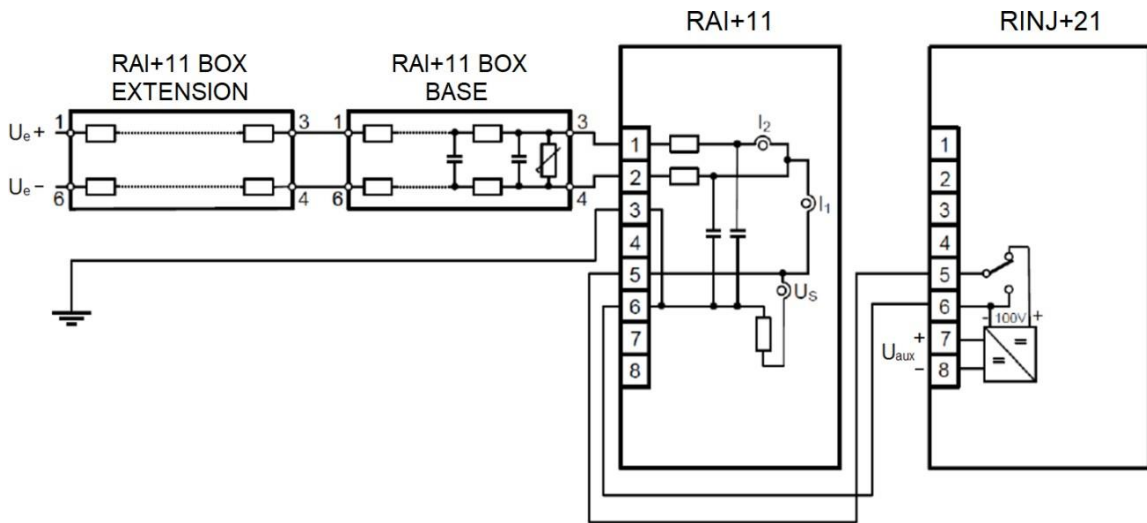

Figure 15-3 Wiring for ungrounded (isolated) rotors

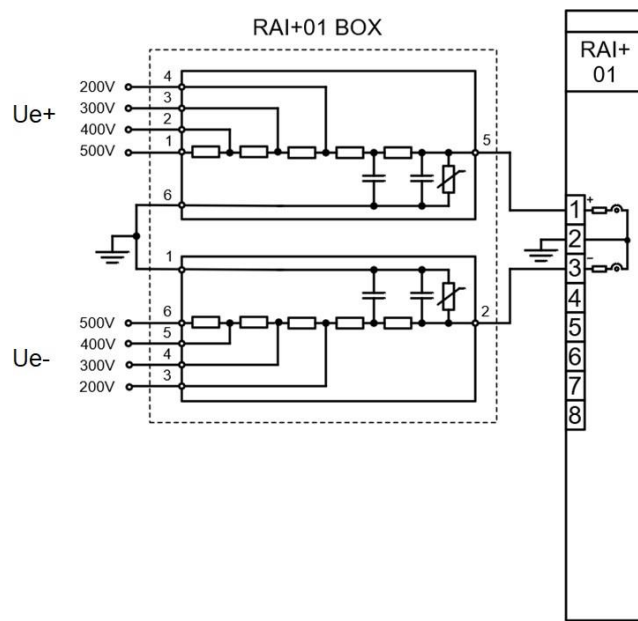
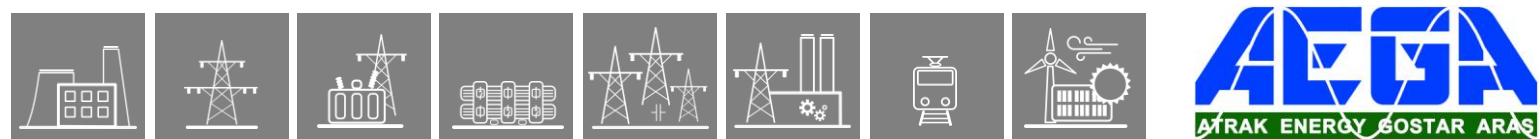

Figure 15-4 Wiring for middle-grounded rotors



1.3.18. Power supply module

The power supply module converts primary AC and/or DC voltage to required system voltages. In most applications, one power supply module is sufficient to provide the required power to the system. Redundant power supply modules extend system availability in case of the outage of any power source.

IMPORTANT

Depending on the hardware configuration, the power consumption of the devices can be different. We reserve the right to make the decision about which PS+ module must be used.

For most applications where the power consumption does not reach 20 W, a 4 HP wide PS+ module shall be installed.

Connector types:

- The default and optionally available connector types are indicated for each module in the tables below. See Chapter [20.2](#) for details about each type.

MODULE TYPE	PS+/4201 (4 HP wide)	PS+/2101 (4 HP wide)
RATED VOLTAGE	24 V DC / 48 V DC / 60 V DC	110 V DC / 220 V DC
INPUT VOLTAGE OPERATIVE RANGE	19.2 - 72 V DC	88 - 264 V DC 80 - 250 V AC
NOMINAL POWER	20 W	20 W
VOLTAGE DIP WITHSTAND AT 80% UN → 0% INPUT VOLTAGE CHANGE (IEC 60255-26)	50 ms	100 ms
INTERNAL FUSE	3.15A/250V	3.15A/250V
CONNECTOR TYPE	Default: BLA Options: T	Default: BLA Options: F, T

IMPORTANT

Devices with 20W or higher power consumption shall be equipped with an 8 HP wide PS module.

MODULE TYPE	PS+/1301	PS+/1303**	PS+/2301	PS+/2303**	PS+/1030*
RATED VOLTAGE	110 V DC	110 V DC	220 V DC	220 V DC	110 V DC / 220 V DC
INPUT VOLTAGE OPERATIVE RANGE	88 - 132 V DC 85 - 130 V AC	88 - 150 V DC 85 - 130 V AC	176 - 264 V DC 160 - 250 V AC	176 - 264 V DC 160 - 250 V AC	88 - 264 V DC 85 - 250 V AC
MAX. CONTINUOUS POWER OUTPUT	30 W	30 W	30 W	30 W	25 W
VOLTAGE DIP WITHSTAND AT 80% UN → 0% INPUT VOLTAGE CHANGE (IEC 60255-26)	50 ms 100 ms at 100%Un → 0%	50 ms 100 ms at 100%Un → 0%	50 ms 100 ms at 100%Un → 0%	50 ms 100 ms at 100%Un → 0%	20 ms 100 ms at 100%Un → 0%
INTERNAL FUSE	2.5A/250V	2.5A/250V	2.5A/250V	2.5A/250V	2.5A/250V
CONNECTOR TYPE	<u>Default:</u> BLA <u>Options:</u> -	<u>Default:</u> BLA <u>Options:</u> -	<u>Default:</u> BLA <u>Options:</u> -	<u>Default:</u> BLA <u>Options:</u> -	<u>Default:</u> BLA <u>Options:</u> F, T

*Special module, available only in custom configurations.

**Can be connected in parallel.

MODULE TYPE	PS+/1060*	PS+/1601	PS+/1602*	PS+/2601	PS+/4301***
RATED VOLTAGE	110 V DC / 220 V DC	110 V DC	110 V DC	220 V DC	48 V DC
INPUT VOLTAGE OPERATIVE RANGE	88 - 264 V DC	88 - 132 V DC 95 - 130 V AC	88 - 132 V DC 95 - 130 V AC	176 - 264 V DC 160 - 250 V AC	38.4 - 57.6 V DC
MAX. CONTINUOUS POWER OUTPUT	60 W	60 W	60 W	60 W	25 W
VOLTAGE DIP WITHSTAND AT 80% UN → 0% INPUT VOLTAGE CHANGE (IEC 60255-26)	20 ms 100 ms at 100%Un → 0%	50 ms 100 ms at 100%Un → 0%	50 ms 100 ms at 100%Un → 0%	50 ms 100 ms at 100%Un → 0%	20 ms 30 ms at 100%Un → 0%
INTERNAL FUSE	3.15A/250V	2.5A/250V	2.5A/250V	2.5A/250V	3.15A/250V
CONNECTOR TYPE	<u>Default:</u> BLA <u>Options:</u> F, T	<u>Default:</u> BLA <u>Options:</u> -	<u>Default:</u> BLA <u>Options:</u> F	<u>Default:</u> BLA <u>Options:</u> T	<u>Default:</u> BLA <u>Options:</u> -

*Special module, available only in custom configurations. PS+1602 supports **auxiliary voltage measurement**. The module is calibrated to DC voltage measurement.

***Obsolete module. These modules are not recommended for new designs!

MODULE TYPE	PS+/2161*	PS+/2164**	PS+/4261*	PS+/4264**
RATED VOLTAGE	110 V DC / 220 V DC	110 V DC / 220 V DC	24 V DC / 48 V DC / 60 V DC	24 V DC / 48 V DC / 60 V DC
INPUT VOLTAGE OPERATIVE RANGE	88 - 264 V DC	88 - 264 V DC	19.2 - 72 V DC	19.2 - 72 V DC
MAX. CONTINUOUS POWER OUTPUT	60 W	60 W	60 W	60 W
VOLTAGE DIP WITHSTAND AT 80% UN → 0% INPUT VOLTAGE CHANGE (IEC 60255-26)	40 ms	40 ms	40 ms	40 ms
INTERNAL FUSE	3.15A/250V	3.15A/250V	8A/250V	8A/250V
CONNECTOR TYPE	Default: BLT Options: -	Default: BLT Options: -	Default: BLT Options: -	Default: BLT Options: -

***Can be connected in parallel.**Can be connected in parallel and supports auxiliary voltage measurement.**

MODULE TYPE	PS+/4401**	PS3F+/1001*
RATED VOLTAGE	48 V DC / 60 V DC	3x100 V AC (line voltage)
INPUT VOLTAGE OPERATIVE RANGE	38.4 - 72 V DC	80 - 120 V AC
MAX. CONTINUOUS POWER OUTPUT	30 W	20 W
VOLTAGE DIP WITHSTAND AT 80% UN → 0% INPUT VOLTAGE CHANGE (IEC 60255-26)	20 ms 30 ms at 100%Un → 0%	50 ms 100 ms at 100%Un → 0%
INTERNAL FUSE	3.15A/250V	2.5A/250V
CONNECTOR TYPE	Default: BLA Options: F, T	Default: BLA Options: -

***Special module.** At least 2 healthy phase voltages are needed for the operation of the PS3F+1001 module. LEDs on the front of the module indicate the presence of healthy phase voltages. For the correct internal signals connect the common point of the supplying 3 phase voltage to the 4th connector ("N").

****Can be connected in parallel.**

Main features:

- Fault relay contacts (NC and NO): device fault contact and also assignable to user functions. All the three relay contact points are accessible to users.
- Redundant applications (nominal power and reliability can be increased by using parallel power supplies)
- On-board self-supervisory circuits: temperature and voltage monitors
- Short-circuit-protected outputs
- Efficiency: > 70 %, power consumption = nominal power / efficiency
- Passive heatsink

- Early power failure indication signals to the CPU for the possibility of power outage, thus the CPU has enough time to save the necessary data to non-volatile memory
- Inrush current (until 0.1 s): < 10 A for all types excluding PS+4401 which has < 21 A inrush current.
- Common features for internal fuses:
 - 5 mm x 20 mm (0.20" x 0.79")
 - TT characteristics (very inverse time-lag)
 - 35 A @ 250 V AC rated breaking capacity
- Recommended external protection: miniature circuit breaker, 6 A (C char.)

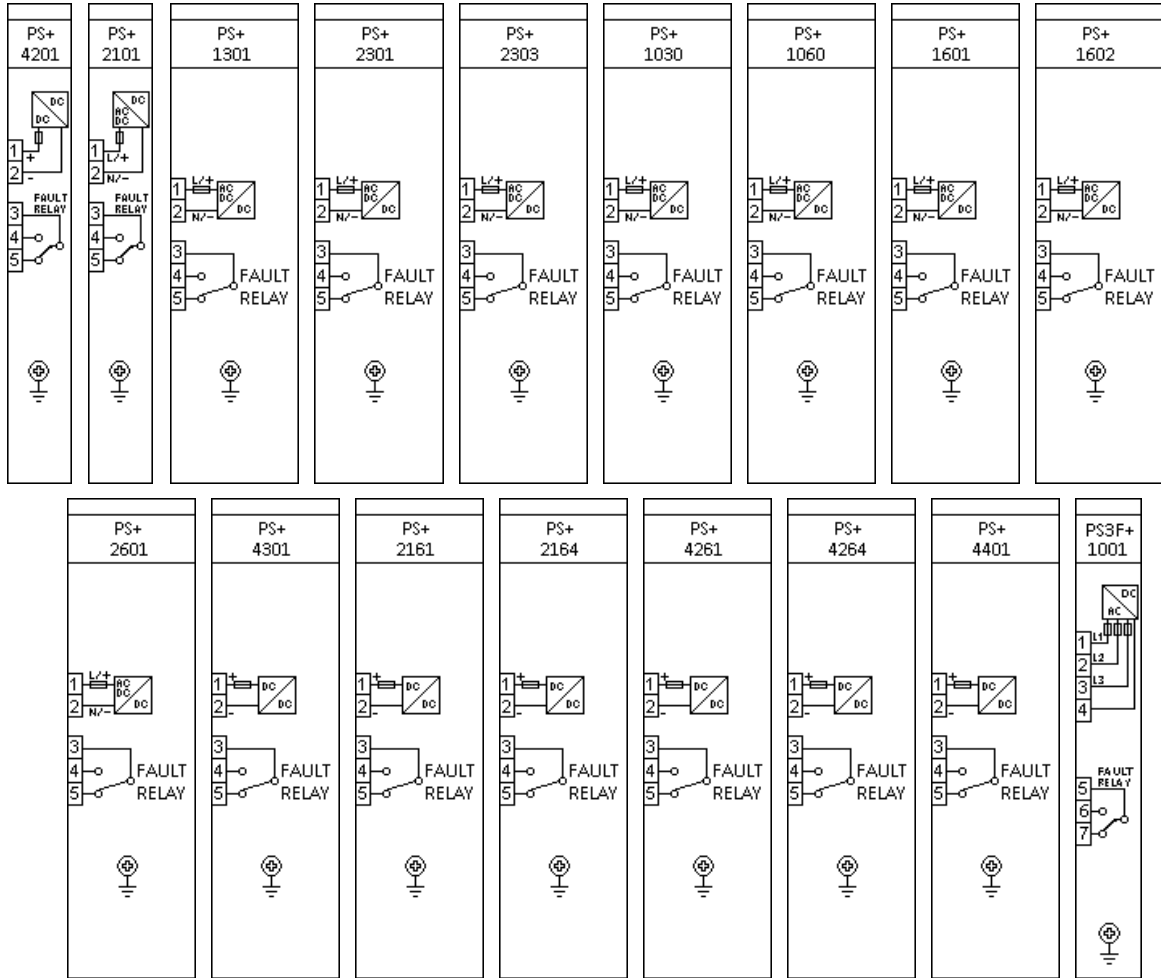

Figure 16-1 Power supply modules

1.3.19. Sampling synchronization module

The IED sampling system is synchronized via this module to an external source (IRIG-B) in PMU (Phasor Measurement Unit) applications. The PLL of the module handles the setting of the phase and frequency if valid IRIG-B signal is received. Note that the sampling signal is generated even if the IRIG-B signal is not present, however in that case, it runs independently.

MODULE TYPE	TSYNC+/0071
IRIG-B TYPE	B000 (unmodulated)
INPUT TYPE	BNC (coaxial)
SIGNAL THRESHOLD	5 VDC CMOS max. 5.5 VDC
MAX. CABLE LENGTH	50 m
CLAMP VOLTAGES	falling 1.7 VDC rising 3.1 VDC
SAMPLING ACCURACY*	< 100 ns
IRIG SYNCH. TIME	max. 1 minute
HOLDOVER TIME**	30 s
SAMPLING FREQUENCY	2 kHz @ 50 Hz 2.4 kHz @ 60 Hz
SAMPLING ACCURACY IN INDEPENDENT MODE***	< 1 ppm

*max. time difference between synchronized systems connecting to different GNSS (e.g. GPS)

**the sampling accuracy stays below the given value during this time if the IRIG-B signal is lost

***the accuracy of the 2/2.4 kHz sampling signal if an IRIG-B signal is not present

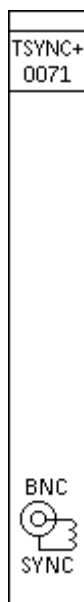

Figure 17-1 Sampling synchronization module

1.3.20. Mixed function modules

1.3.20.1. PSTP+ module

IMPORTANT

PSTP+ modules can be used only if the power consumption of the device does not reach 20 W and maximum 2 TRIP contacts are needed. If the application does not meet any of these two requirements, it is not allowed to use these cards. In this case separate PS+ (Chapter 16) and TRIP+ (Chapter 9) modules must be used.

Connector types:

- The default and optionally available connector types are indicated for each module in the tables below. See Chapter 20.2 for details about each type.

Note for the following tables:

- Thermal withstand voltage:** continuous with 60 % of the input channels are energized.

MODULE TYPE	PSTP+/2101	PSTP+/2102*	PSTP+/2131**
	POWER SUPPLY CHARACTERISTICS		
RATED VOLTAGE	110 V / 220 V	110 V / 220 V	110 V / 220 V
INPUT VOLTAGE OPERATIVE RANGE	88 - 264 V DC 80 - 250 V AC	88 - 264 V DC 80 - 250 V AC	88 - 264 V DC 80 - 250 V AC
MAXIMUM CONTINUOUS POWER OUTPUT	20 W	20 W	20 W
VOLTAGE DIP DURATION AT 0% RESIDUAL VOLTAGE (IEC 60255-26)	min. 100 ms in the specified input voltage range	min. 100 ms in the specified input voltage range	min. 100 ms in the specified input voltage range
INTERNAL FUSE	3.15A/250V	3.15A/250V	3.15A/250V
CONNECTOR TYPE	<u>Default:</u> BLA <u>Options:</u> F, T	<u>Default:</u> BLA <u>Options:</u> F, T	<u>Default:</u> BLA <u>Options:</u> T
	TRIPPING CHARACTERISTICS		
CHANNEL NUMBER	2	2	2
RATED VOLTAGE	110 V DC and 220 V DC or dry contacts	110 V DC and 220 V DC or dry contacts	110 V DC and 220 V DC or dry contacts
THERMAL WITHSTAND VOLTAGE	242 V DC	242 V DC	242 V DC
CONTINUOUS CARRY	8 A	8 A	8 A
MAKING CAPACITY	0.5 s, 30 A	0.5 s, 30 A	0.5 s, 30 A
BREAKING CAPACITY	L/R = 40 ms: 4 A DC	L/R = 40 ms: 4 A DC	L/R = 40 ms: 4 A DC
CONNECTOR TYPE	<u>Default:</u> BLA <u>Options:</u> F, T	<u>Default:</u> BLA <u>Options:</u> F, T	<u>Default:</u> BLA <u>Options:</u> T

*Special module that supports **auxiliary voltage measurement**. The module is calibrated to DC voltage measurement.

**Without trip circuit supervision

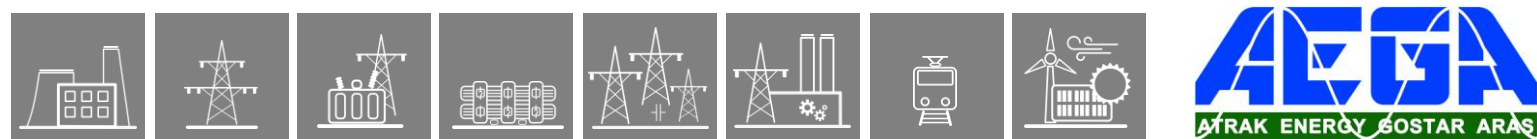

MODULE TYPE	PSTP+/4201	PSTP+/4202*
POWER SUPPLY CHARACTERISTICS		
RATED VOLTAGE	24 V / 48 V / 60 V	24 V / 48 V / 60 V
INPUT VOLTAGE OPERATIVE RANGE	19.2 - 72 V DC	19.2 - 72 V DC
MAXIMUM CONTINUOUS POWER OUTPUT	20 W	20 W
VOLTAGE DIP DURATION AT 0% RESIDUAL VOLTAGE (IEC 60255-26)	50 ms at nominal input voltages min. 40 ms in the specified input voltage range	50 ms at nominal input voltages min. 40 ms in the specified input voltage range
INTERNAL FUSE	3.15A/250V	3.15A/250V
CONNECTOR TYPE	<u>Default:</u> BLA <u>Options:</u> T	<u>Default:</u> BLA <u>Options:</u> T
TRIPPING CHARACTERISTICS		
CHANNEL NUMBER	2	2
RATED VOLTAGE	24 V DC and 48 V DC or dry contacts	24 V DC and 48 V DC or dry contacts
THERMAL WITHSTAND VOLTAGE	72 V DC	72 V DC
CONTINUOUS CARRY	8 A	8 A
MAKING CAPACITY	0.5 s, 30 A	0.5 s, 30 A
BREAKING CAPACITY	L/R = 40 ms: 4 A DC	L/R = 40 ms: 4 A DC
CONNECTOR TYPE	<u>Default:</u> BLA <u>Options:</u> T	<u>Default:</u> BLA <u>Options:</u> T

***Special module** that supports **auxiliary voltage measurement**. The module is calibrated to DC voltage measurement.

Main features:

- High-speed operation: with pre-trip 0.5 ms, without pre-trip typically 10 ms, maximally 22 ms.
- Trip circuit supervision for each trip contact
- 1 unit wide (4 HP) modules
- Inrush current (until 0.1 s): < 10 A
- Common features for internal fuses:
 - 5 mm x 20 mm (0.20" x 0.79")
 - TT characteristics (very inverse time-lag)
 - 35 A @ 250 V AC rated breaking capacity
- Recommended external protection: miniature circuit breaker, 6 A (C char.)

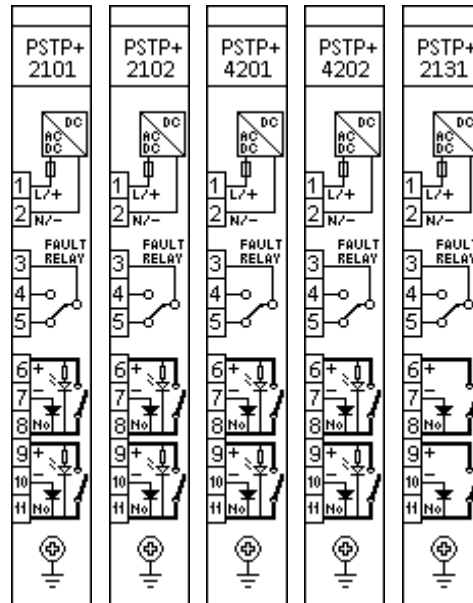

Figure 18-1 Power supply with 2 Ch. TRIP modules

1.3.20.1.1. Trip Circuit Supervision (TCS) in PSTP modules

Apart from the PSTP+/2131, all PSTP modules have TCS.

The technical data of the TCS in PSTP modules:

	MODULE TYPE	PSTP+/4201 PSTP+/4202	PSTP+/2101 PSTP+/2102
	INJECTED CURRENT AT "NO" CONTACT	1.5 mA	1.5 mA
MAXIMUM RESISTANCE OF THE TRIP COIL	3-WIRE WIRING (1 mA CURRENT)	8 kΩ (max. 8 V)	13 kΩ (max. 13 V)
	3-WIRE WIRING IN PARALLEL	4 kΩ (max. 8 V)	6.5 kΩ (max. 13 V)
	2-WIRE METHOD (1 mA MIN. CURRENT)	24 kΩ @ 24 V DC 48 kΩ @ 48 V DC 60 kΩ @ 60 V DC	110 kΩ @ 110 V DC 220 kΩ @ 220 V DC

IMPORTANT

PSR2+ modules can be used only if the power consumption of the device does not reach 20 W and maximum 2 contacts are needed. If the application does not meet any of these two requirements it is not allowed to use these cards. In this case separate PS+ (Chapter 16) and Signaling (Chapter 8) modules must be used.

1.3.20.2. PSR2+ module

Connector types:

- The default and optionally available connector types are indicated for each module in the table below. See Chapter 20.2 for details about each type.

MODULE TYPE	PSR2+/2101
POWER SUPPLY CHARACTERISTICS	
RATED VOLTAGE	110 V / 220 V
INPUT VOLTAGE OPERATIVE RANGE	88 - 264 V DC 80 - 250 V AC
MAXIMUM CONTINUOUS POWER OUTPUT	20 W
VOLTAGE DIP DURATION AT 0% RESIDUAL VOLTAGE (IEC 60255-26)	min. 100 ms in the specified input voltage range
INTERNAL FUSE	3.15A/250V
CONNECTOR TYPE	<u>Default:</u> BLA <u>Options:</u> T
SIGNALING RELAY CHARACTERISTICS	
CHANNEL NUMBER	2
RATED VOLTAGE	250 V AC/DC
CONTINUOUS CARRY	8 A
MAKING CAPACITY	0.5 s, 30 A
CONNECTOR TYPE	<u>Default:</u> BLA <u>Options:</u> T

Main features (according to IEC 60255-26):

- Maximum switching voltage: 400 V AC
- Breaking capacity: (L/R=40 ms) at 220 V DC: 0.2 A, at 110 V DC: 0.3 A
- Breaking capacity max.: 2000 VA
- Short time carrying capacity: 1 s, 35 A
- Limiting making current, max. 4 s: 15 A (df = 10 %)
- Dielectric strength between open contacts, 1 min: 1000 V_{RMS}
- Mechanical endurance: 10 × 10⁶ cycles
- Circuit closing capability: typically 10 ms, maximally 22 ms.
- Bounce time: typically 6,5 ms, maximally 10 ms.
- Minimal switching requirement: 5 V

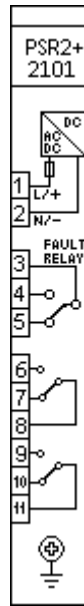
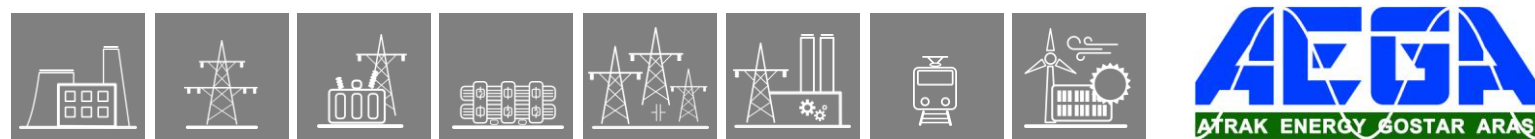

Figure 18-2 Power supply with 2 Ch. signaling modules



1.3.20.3. O6R5+ module

The O6R5+ module contains 6 binary input channels in one grounding group, and 5 relay outputs with 2 × 2 NO contacts and one CO contact.

Connector types:

- The default and optionally available connector types are indicated for each module in the tables below. See Chapter 20.2 for details about each type.

Notes for the following table:

- **Thermal withstand voltage:** continuous with 60 % of the input channels are energized.
- **Clamp voltage:** these are the guaranteed values; the actual ones might differ from those provided here (falling and rising around 0.66 U_N and 0.77 U_N , respectively)

MODULE TYPE	O6R5+/2101	O6R5+/4201
BINARY INPUT CHARACTERISTICS		
CHANNEL NUMBER	6	6
RATED VOLTAGE	110 V / 220 V user selectable on channel basis by jumpers	24 V / 48 V user selectable on channel basis by jumpers
TIME SYNCHRONIZATION	configured by EuroCAP	configured by EuroCAP
THERMAL WITHSTAND VOLTAGE	320 V	72 V
CLAMP VOLTAGE	falling 0.64 U_N rising 0.8 U_N	falling 0.64 U_N rising 0.8 U_N
COMMON GROUPS	1 × 6 common	1 × 6 common
RELAY OUTPUT CHARACTERISTICS		
RATED VOLTAGE	250 V AC/DC	250 V AC/DC
CONTINUOUS CARRY	8 A	8 A
CONTACT VERSIONS	4 NO, 1 CO	4 NO, 1 CO
GROUP ISOLATION	2 × 2 common, 1 independent	2 × 2 common, 1 independent
CONNECTOR TYPE FOR BOTH BINARY INPUT AND RELAY OUTPUT	<u>Default:</u> BLA <u>Options:</u> T	<u>Default:</u> BLA <u>Options:</u> T

Main features for binary inputs:

- Digitally filtered per channel
- Current drain:
 - max. 1.6 mA per channel at 220 V DC
 - max. 1.8 mA per channel at 110 V DC
 - max. 2 mA per channel at 48 V DC
 - max. 3 mA per channel at 24 V DC
- In such applications where the input voltage is 60 V the modules with 48 V rated voltage can be used.
- Input voltage type can be either DC or AC voltage. If AC voltage is used make sure that the type and the parameters of the binary inputs are configured properly in EuroCap tool.

Main features for signaling outputs:

- Maximum switching voltage: 400 V AC
- Breaking capacity, (L/R=40 ms) at 220 V DC: 0.1 A, at 110 V DC: 0.2 A
- Breaking capacity max.: 2000 VA
- Short time carrying capacity: 1 s, 35 A
- Limiting making current, max. 4 s: 15 A (df = 10 %)
- Initial dielectric strength between open contacts, 1 min: 1000 V_{RMS}
- Circuit closing capability: typically 10 ms, maximally 22 ms.
- Bounce time: typically 6,5 ms, maximally 10 ms.
- Mechanical endurance: 10 × 10⁶ cycles
- Circuit closing capability

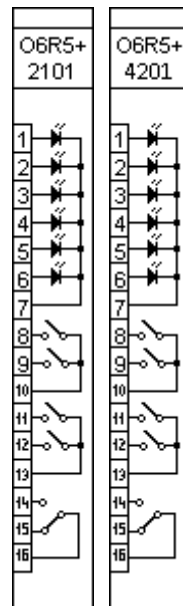

Figure 18-3 Binary input/output modules

1.3.20.4. Binary input module with time synchronization

The inputs are galvanically isolated and the module converts high-voltage signals to the voltage level and format of the internal circuits. This module is also used as an external IRIG-B synchronization (**IRIG-B000, unmodulated**), PPM or PPS input. Dedicated synchronization input is used for this purpose.

Connector types:

- The default and optionally available connector types are indicated for each module in the tables below. See Chapter 20.2 for details about each type.

Notes for the following table:

- **Thermal withstand voltage:** continuous with 60 % of the input channels are energized.
- **Clamp voltage:** these are the guaranteed values; the actual ones might differ from those provided here (falling and rising around $0.66 U_N$ and $0.77 U_N$, respectively)

MODULE TYPE	O9S+/2111	O9S+/2121	O9S+/4221
CHANNEL NUMBER	9	9	9
SYNCHRON CHANNEL TYPE AND NUMBER	1 isolated BNC connector	1 850 nm multimode fiber with ST connector	1 850 nm multimode fiber with ST connector
RATED VOLTAGE	110 V DC / 220 V DC user selectable by jumpers	110 V DC / 220 V DC user selectable by jumpers	24 V DC / 48 V DC user selectable by jumpers
THERMAL WITHSTAND VOLTAGE	320 V	320 V	72 V
WITHSTAND VOLTAGE FOR SYNC. INPUT	35 V _{PEAK}	-	-
CLAMP VOLTAGE	falling $0.64 U_N$ rising $0.8 U_N$	falling $0.64 U_N$ rising $0.8 U_N$	falling $0.64 U_N$ rising $0.8 U_N$
COMMON GROUPS	9 (3 × 3 common)	9 (3 × 3 common)	9 (3 × 3 common)
CONNECTOR TYPE	<u>Default:</u> BLA <u>Options:</u> T	<u>Default:</u> BLA <u>Options:</u> F, T	<u>Default:</u> - <u>Options:</u> F, T

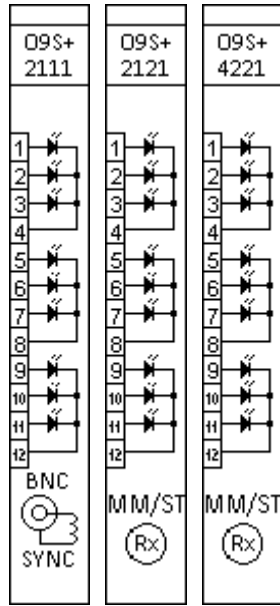

Figure 18-4 Binary input modules with time synchronization

1.3.20.5. Externally driven trip module

The R4MC+01 is a special TRIP module, which can be operated from the connector side. It also has two diode inputs with cathodes which are connected and led to the connector side.

Connector types:

- The default and optionally available connector types are indicated for each module in the tables below. See Chapter 20.2 for details about each type.

Module type	R4MC+/01*
CHANNEL NUMBER	2
RATED VOLTAGE	110 V DC
THERMAL WITHSTAND VOLTAGE	132 V DC
CONTINUOUS CARRY	8 A
MAKING CAPACITY	0.5 s, 30 A
BREAKING CAPACITY	L/R = 40 ms: 4 A DC
DIODE PROPERTIES	1 A, 1000 V DC
CONNECTOR TYPE	<u>Default:</u> BLA <u>Options:</u> F

*Special module



Figure 18-5 Externally driven TRIP module



1.3.21. General data

- Storage temperature: - 40 °C ... + 70 °C
- Operation temperature: - 20 °C ... + 55 °C
- Humidity: 10 % ... 93 %
- Altitude: up to 2000 m
- Atmospheric pressure: 86 ... 106 kPa

1.3.21.1. Standard conformance

- Electrostatic discharge immunity (ESD), IEC-EN 60255-26:2013, Level 4
 - Test voltages: 15 kV air discharge, 8 kV contact discharge
- Radiated, radio-frequency, electromagnetic field immunity, IEC-EN 60255-26:2013 Level 3
 - Test field strength: 10 V/m
- Electrical fast transient/burst immunity (EFT/B), IEC-EN 60255-26:2013, Level 4
 - Test voltage: 4 kV
- Surge immunity test, IEC-EN 60255-26:2013
 - Test voltages: 4 kV line-to-earth, 2 kV line-to-line
- Immunity to conducted disturbances, induced by radio-frequency fields, IEC-EN 60255-26:2013, Level 3
 - Test voltage: 10 V
- Damped oscillatory wave immunity test, IEC-EN 60255-26:2013
 - Test frequency: 1 MHz
 - Test voltage: 2.5 kV in common mode, 1 kV in differential mode
- Voltage dips, short interruptions and voltage variations immunity, IEC-EN 60255-26:2013
 - Voltage dips: 40 % (200 ms), 70 % (500 ms), 80 % (5000 ms)
- Ripple on d.c. input power port immunity, IEC-EN 60255-26:2013
 - Level 4, 15 % of rated d.c. value
- Power frequency magnetic field immunity test, IEC-EN 60255-26:2013, Level 5
 - Test field strength: 100 A/m continuous, 1000 A/m for 3 s
- Power frequency immunity test on the binary inputs, IEC-EN 60255-26:2013, Class A
 - Test voltages: 300 V in common mode, 150 V in differential mode
- Insulation tests, IEC-EN 60255-27:2013
 - Impulse voltage test
 - Test levels: 5 kV (1 kV for transducer and temperature measuring inputs)
 - Dielectric test
 - Test levels: 2 kV AC 50 Hz (0.705 kV DC for transducer inputs)
 - Insulation resistance
 - Insulation resistance > 15 GΩ
- Radiated emission, IEC-EN 60255-26:2013

Limits:

 - 30 MHz to 230 MHz: 50 dB(μV/m) quasi peak, 3 m
 - 230 MHz to 1 000 MHz: 57 dB(μV/m) quasi peak, 3 m
 - 1 GHz to 3 GHz: 76 dB(μV/m) peak, 3 m
 - 3 GHz to 6 GHz: 80 dB(μV/m) peak, 3 m
- Conducted emission, IEC-EN 60255-26:2013

Limits:

 - 0,15 MHz to 0,50 MHz: 79 dB(μV) quasi peak, 66 dB(μV) average
 - 0,5 MHz - 30 MHz: 73 dB(μV) quasi peak, 60 dB(μV) average
- Vibration, shock, bump and seismic tests on measuring relays and protection equipment
 - Vibration tests (sinusoidal), Class I, IEC 60255-21-1:1988
 - Shock and bump tests, Class I, IEC 60255-21-2:1988
 - Seismic tests, Class I, IEC 60255-21-3:1993

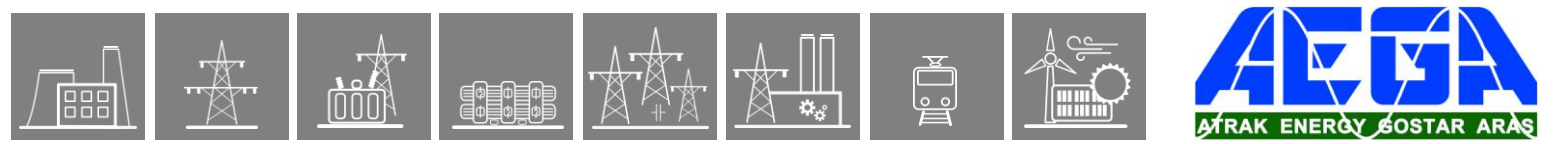

1.3.22. Mechanical data

1.3.22.1. General mechanical data

- Construction: chromate aluminum surface with built-in EMC accessories
 - If the power consumption of a 84 HP or 42 HP device does not exceed 30 W (84 HP) or 14 W (42 HP), the construction will be built with solid top and bottom cover panels.
 - If the power consumption exceeds 30 W (84 HP) or 14 W (42 HP), the construction will be built with (honeycomb) perforated top and bottom cover panels.
- EMC rack protects against electromagnetic environmental influences and protects the environment from radiation from the interior
- IP protection:
 - 24 HP panel instrument case: IP4x; optionally IP54 (front)
 - 84 HP and 42 HP (including double) rack: IP4x from front side, IP2x from rear side; optionally IP54 (front)
- Size:
 - 19" (84 HP), 3 U, single rack
 - ½ 19" (42 HP), 3 U, single rack
 - ½ 19" (42 HP), 6 U, double rack
 - 24 HP, panel instrument case
- Weight:
 - 84 HP: max. 8 kg
 - 42 HP, 3 U: max. 4.5 kg
 - 42 HP, 6 U: max. 8 kg
 - 24 HP: max. 3 kg

1.3.22.2. Connectors

Optionally, certain modules can be equipped with different terminals for different connectors. The available choices are listed among each module's technical data with their *short ID* (see the first column of the table below).

The type of the used terminal is indicated on the module's label with its *short ID* (see the following example). The actual type of the connector is chosen according to the number of the available pins of the module.

Example: the *VT+/2211* module may have four types of connectors. In its description (Chapter 6), these are indicated with their ID:

- The default terminal is indicated with nothing attached (*VT+/2211*), only its name (BLA) is mentioned. Since it has 8 pins, the type is BLA 8/180
- The flanged terminal's *short ID* is **F**, so the module's label will be "*VT+/2211F*", if it is equipped with this terminal (BLA 8B/180)
- Top-screw terminal: **T**, the label becomes "*VT+/2211T*" (BLT 5.08HC/08/180F)
- Ring-lug terminal: **R**, so the module's label shall be "*VT+/2211R*"

CONNECTOR NAME (SHORT ID)	CONNECTOR TYPES	STRIP LENGTH [MM]	CONDUCTOR AREA [MM ²]	CONDUCTOR DIAMETER [MM]	TIGHTENING TORQUE [NM]	MINIMUM BEND RADIUS*
BLA (-)	Weidmüller BLA 2/180, BLA 3/180, BLA 4/180, BLA 6/180, BLA 8/180, BLA 10/180, BLA 12/180, BLA 13/180, BLA 16/180	7	0.2 – 1.5 solid: 0.2 – 2.5	0.5 – 1.4 solid: 0.5 – 1.8	0.4 – 0.5	3 × OD**
BL 3.5 (-)	Weidmüller BL 3.5/05/180 BL 3.5/09/180	6	0.2 – 1.5	0.5 – 1.4	0.2 – 0.25	3 × OD**
FLANGED (F)	Weidmüller BLA 2B/180, BLA 3B/180, BLA 4B/180, BLA 6B/180, BLA 8B/180, BLA 10B/180, BLA 12B/180, BLA 16B/180	7	0.2 – 1.5 solid: 0.2 – 2.5	0.5 – 1.4 solid: 0.5 – 1.8	0.4 – 0.5	3 × OD**
TOP-SCREW (T)	Weidmüller BLT 5.08HC/06/180F, BLT 5.08HC/08/180F, BLT 5.08HC/12/180F, BLT 5.08HC/16/180F	13	0.2 – 1.5 solid: 0.2 – 2.5	0.5 – 1.4 solid: 0.5 – 1.8	0.4 – 0.5	3 × OD**
RING-LUG (R)	TE Connectivity BC6-Q308-08	-	0.33 – 3.31	0.65 – 2.05	0.79	3 × OD**

* Bend radius is measured along the inside curve of the wire or wire bundles.

** OD is the outer diameter of the wire or cable, including insulation.

CONNECTOR NAME (SHORT ID)	CONNECTOR TYPES	STRIP LENGTH [MM]	CONDUCTOR AREA [MM ²]	CONDUCTOR DIAMETER [MM]	TIGHTENING TORQUE [Nm]	MINIMUM BEND RADIUS*
STVS (-)	Weidmüller STVS 6 SB, STVS 8 SB	9	0.5 – 4	0.8 – 2.3	0.5 – 0.6	3 x OD**
B2L 3.5	Weidmüller B2L 3.5	7	0.2 – 1	0.5 – 1.1	tension clamp connection	3 x OD**
ST/FC/LC	Bayonet/Screw/Snap Fiber Optic	-	-	-	-	30 mm
PE FASTON TERMINAL	TE Connectivity 6.3x0.8	7	min. 4	min. 2.3	-	3 x OD**

* Bend radius is measured along the inside curve of the wire or wire bundles.

** OD is the outer diameter of the wire or cable, including insulation.

The tightening torque of the screw for protective earth connection and the wall mounting must be approx. 5 Nm.

The tightening torque of the screw for fastening the STVS connector must be approx. 1 Nm.

The minimum distance between an EP+ device and its wire channel must be at least 3 cm.

The minimum distance between two EP+ devices must be at least 10 cm.

During the installation make sure that the shortest possible length for PE (Protective Earth) cable routing is applied.

1.3.23. Mounting methods

- Flush mounting
 - 84 HP single rack
 - 42 HP single rack
 - 42 HP double rack
 - 24 HP panel instrument case
 - Remote HMI
- Rack mounting
 - 84 HP single rack
 - 42 HP single rack
 - Remote HMI
- Semi-flush mounting
 - 84 HP single rack
 - 42 HP single rack
 - 24 HP panel instrument case
 - Remote HMI
- Wall mounting (with terminals)
 - 84 HP single rack
 - 42 HP single rack
- Din rail mounting
 - 24 HP panel instrument case
- IP54 rated mounting
 - 84 HP single rack
 - 42 HP single rack
 - 24 HP panel instrument case (original frame with additional gasket)
- Fold-down mounting (with optional terminals)
 - 84 HP single rack
 - 42 HP single rack
- No mounting
 - 84 HP single rack
 - 42 HP single rack

MOUNTING METHOD	84 HP SINGLE RACK	42 HP SINGLE RACK	42 HP DOUBLE RACK	24 HP PANEL INSTRUMENT CASE	REMOTE HMI
FLUSH MOUNTING	X	X	X	X	X
RACK MOUNTING	X	X			X
SEMI-FLUSH MOUNTING	X	X		X	X
WALL MOUNTING (WITH TERMINALS)	X	X			
DIN RAIL MOUNTING				X	
IP54 RATED MOUNTING	X	X		X*	
FOLD-DOWN MOUNTING	X	X			

*additional gasket inserted into the original front panel frame



It is recommended to leave at least 80 mm free space for the wiring at the back of the IED in case of Flush mounting, Rack mounting, and Semi-flush mounting.

1.3.23.1. Flush mounting

Flush mounting can be used for all size of racks (84 HP, 42 HP, double 42 HP) including the 24 HP panel instrument case and the remote HMI devices. When this type of mounting alternative is used the 84 HP, 42 HP, double 42 HP and remote HMI devices have got a cover profile fit on and the 24 HP devices have got a mounting frame fit on.

The dimensions of the cut-outs for the 84 HP and 42 HP devices are also applicable for the same sized remote HMI devices.

1.3.23.1.1. Flush mounting of 84 HP and 42 HP single rack

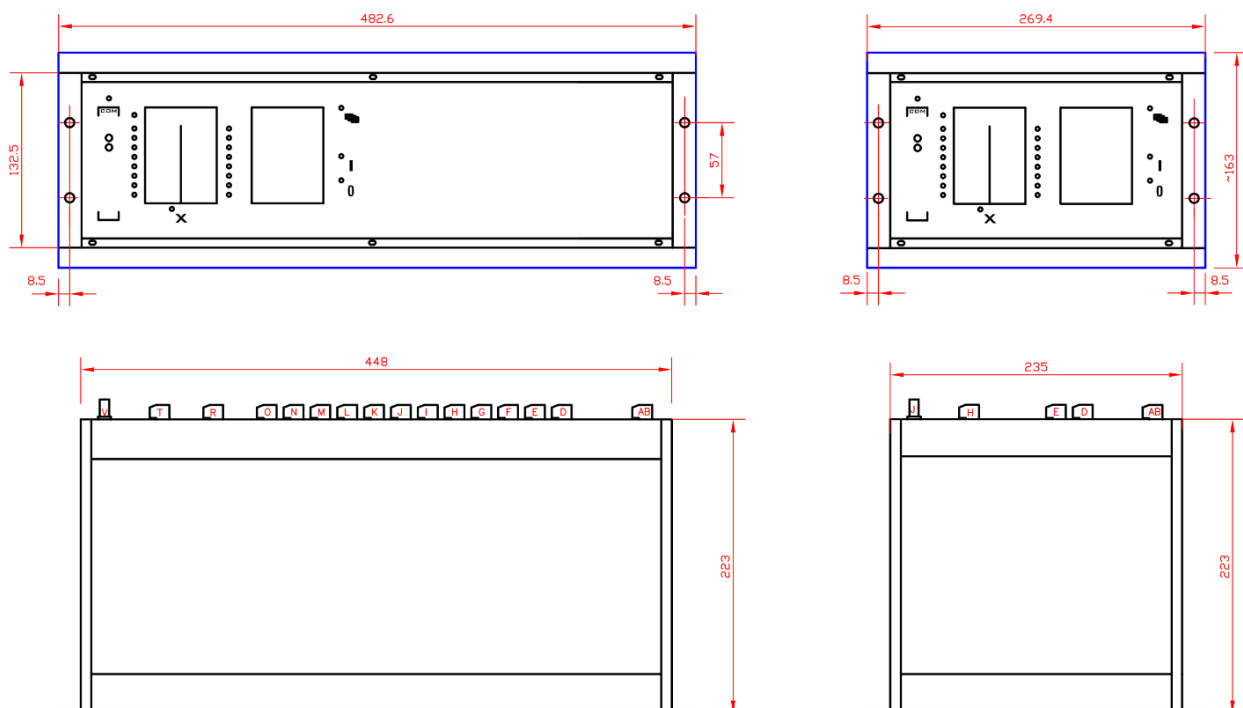

PANEL CUT-OUT

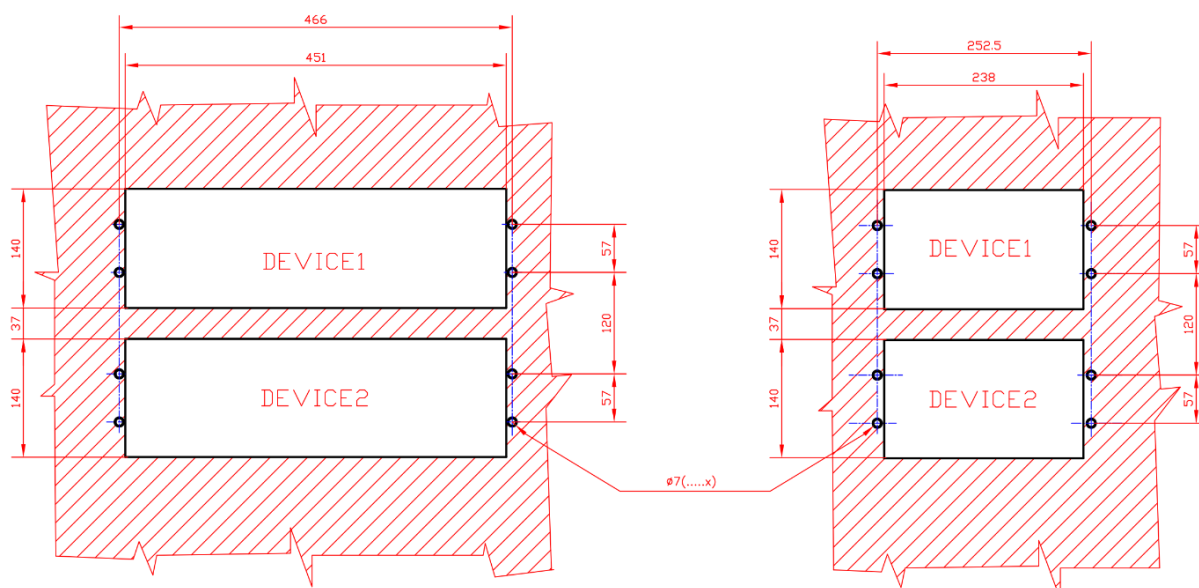

Figure 21-1 Dimensions for flush mounting of 84 HP and 42 HP single rack

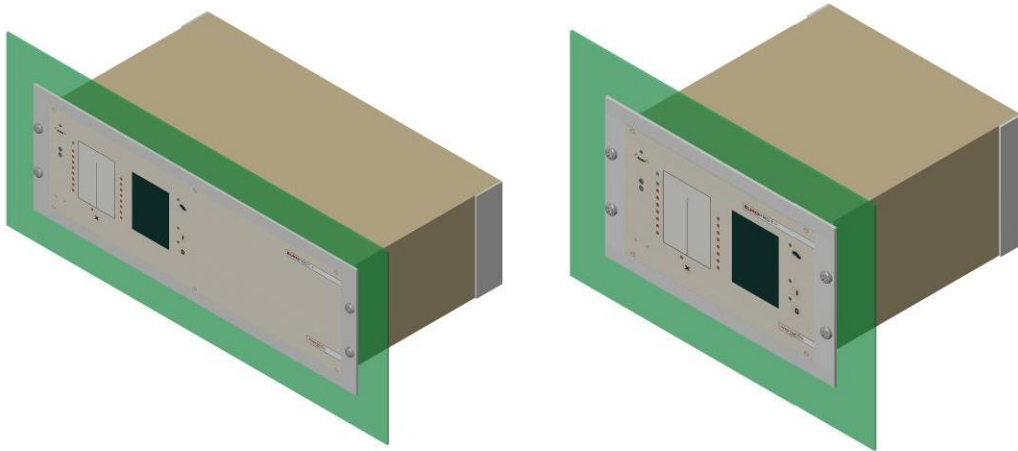

Figure 21-2 3D illustration for flush mounting of 84 HP and 42 HP devices

1.3.23.1.2. Flush mounting of 42 HP double rack

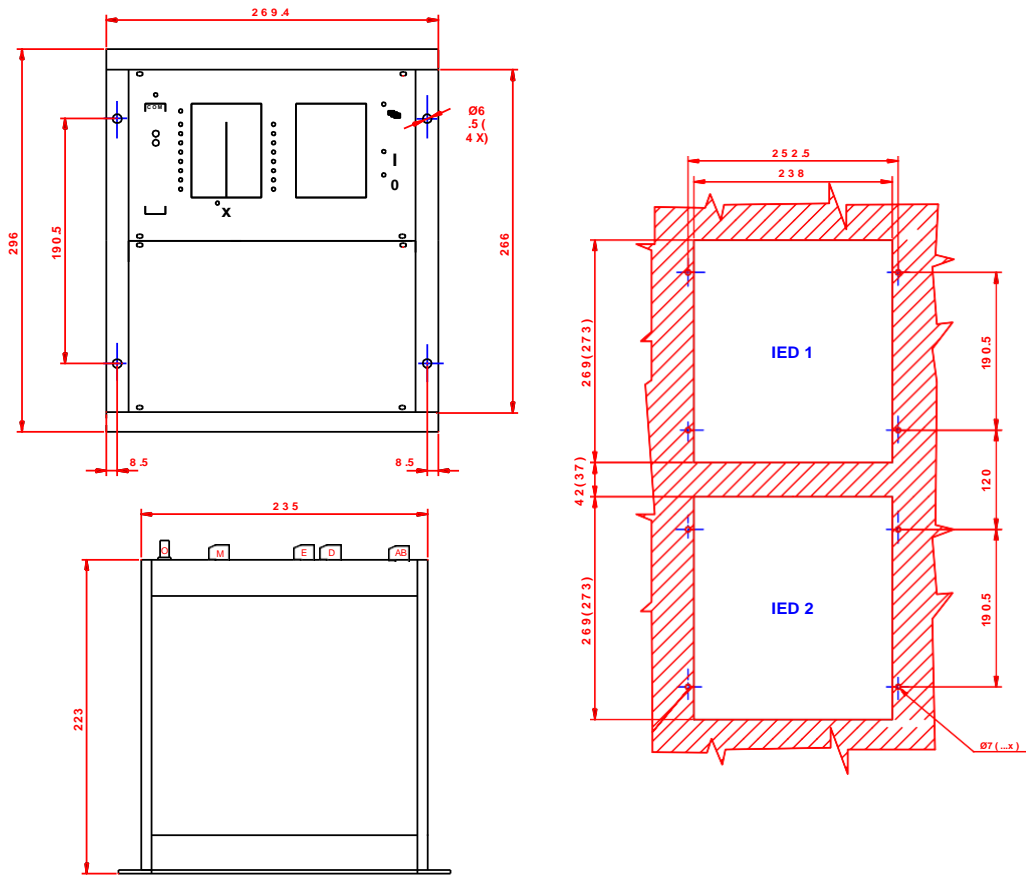

Figure 21-3 Dimensions for flush mounting of 42 HP double rack



Figure 21-4 42 HP wide cover profile

1.3.23.1.3. Flush mounting of 24 HP panel instrument case

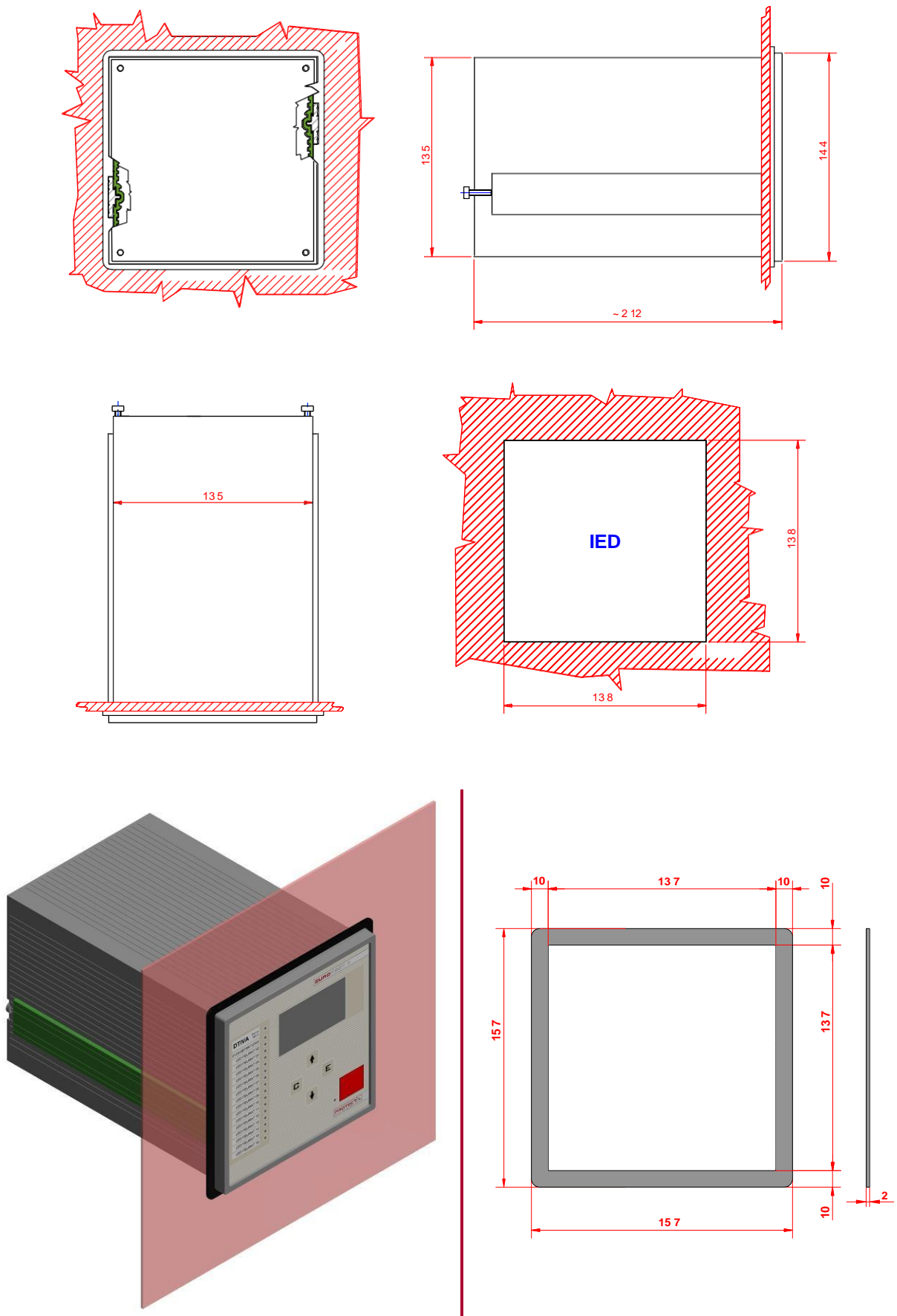

Figure 21-5 Dimensions for flush mounting of 24 HP panel instrument case with 3D illustration

1.3.23.2. Rack mounting

When rack mounting is used, the devices do not have a cover profile fit on, so it is possible to mount them in a 19" rack.

1.3.23.2.1. Rack mounting of 84 HP and 42 HP single rack

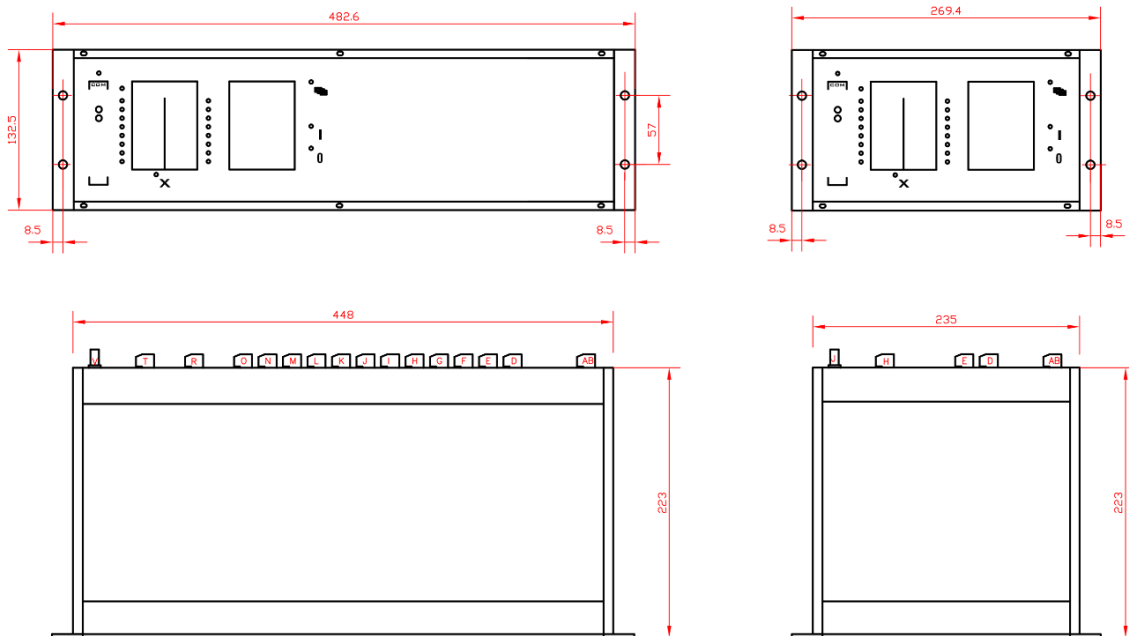

Figure 21-6 Dimensions for rack mounting of 84 HP and 42 HP single rack

Note that rack mounting type devices can also be mounted in a cut-out (e.g. on a switchgear door). It is possible to mount them from the front or from the back of the cut-out. The dimensions for rack mounting cut-outs are in the figure below. Dimensions in brackets are applicable in case of mounting from the back.

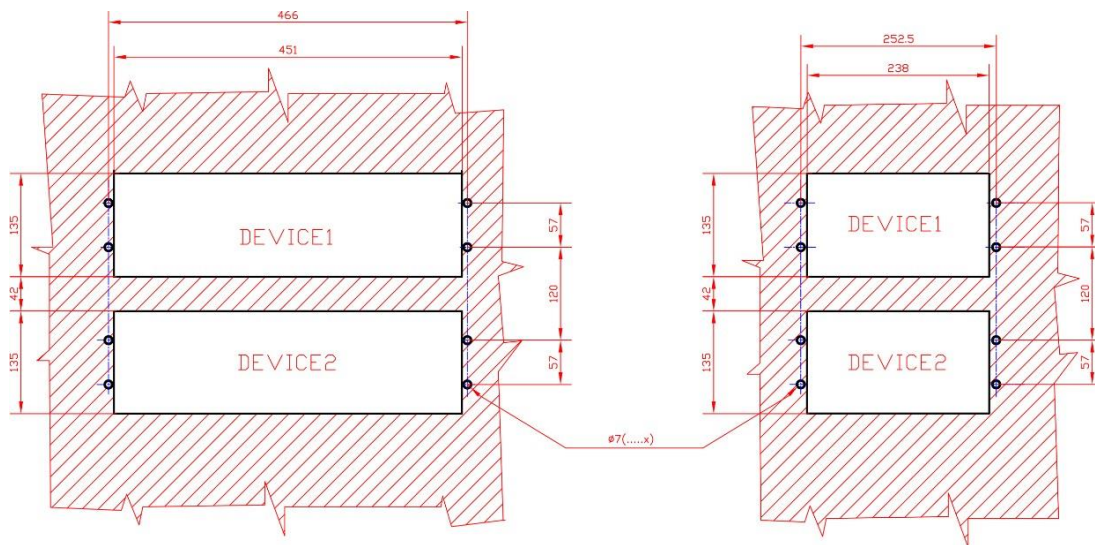
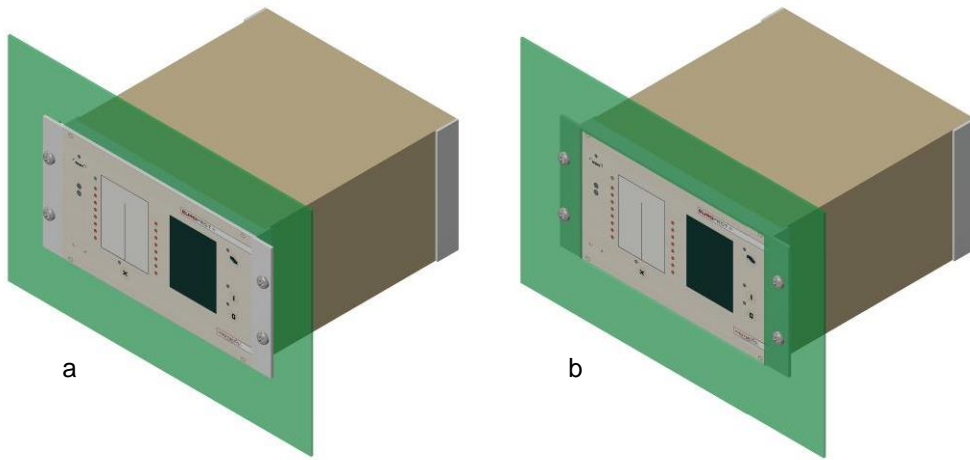
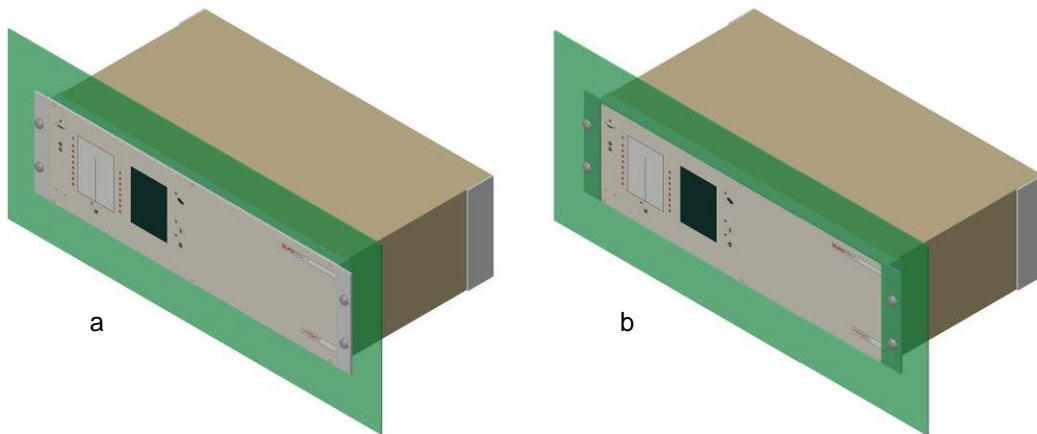

Figure 21-7 Dimensions of rack mounting cut-outs



*Figure 21-8 3D illustration for rack mounting of 42 HP device
(a - from the front; b - from the back)*



*Figure 21-9 3D illustration for rack mounting of 84 HP device
(a - from the front; b - from the back)*

1.3.23.2.2. Rack mounting of 42 HP double rack

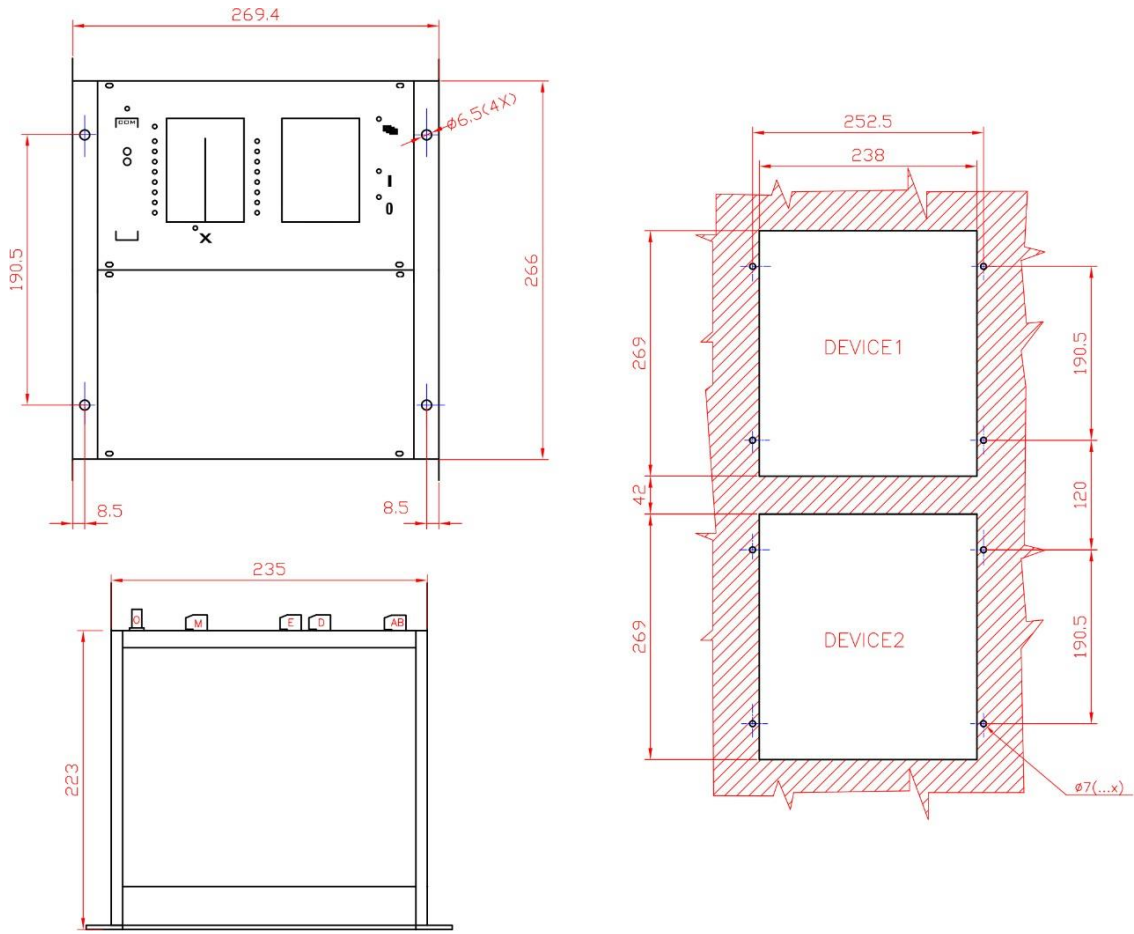

Figure 21-10 Dimensions for rack mounting of 42 HP double rack

1.3.23.3. Semi-flush mounting

Semi-flush mounting can be used for 84 HP and 42 HP single racks, for 24 HP panel instrument cases and for remote HMI devices. The purpose of this type of mounting alternative is to reduce the depth of the devices in the switchgear/rack if there is not enough space in that direction. To achieve this, a special mounting collar must be fit on the rack type devices. The default color of the mounting collar is grey (RAL 7035).

The dimensions of the special mounting collars and the cut-outs for the 84 HP and 42 HP devices are also applicable for the same sized remote HMI devices.

1.3.23.3.1. Semi-flush mounting of 84 HP single rack

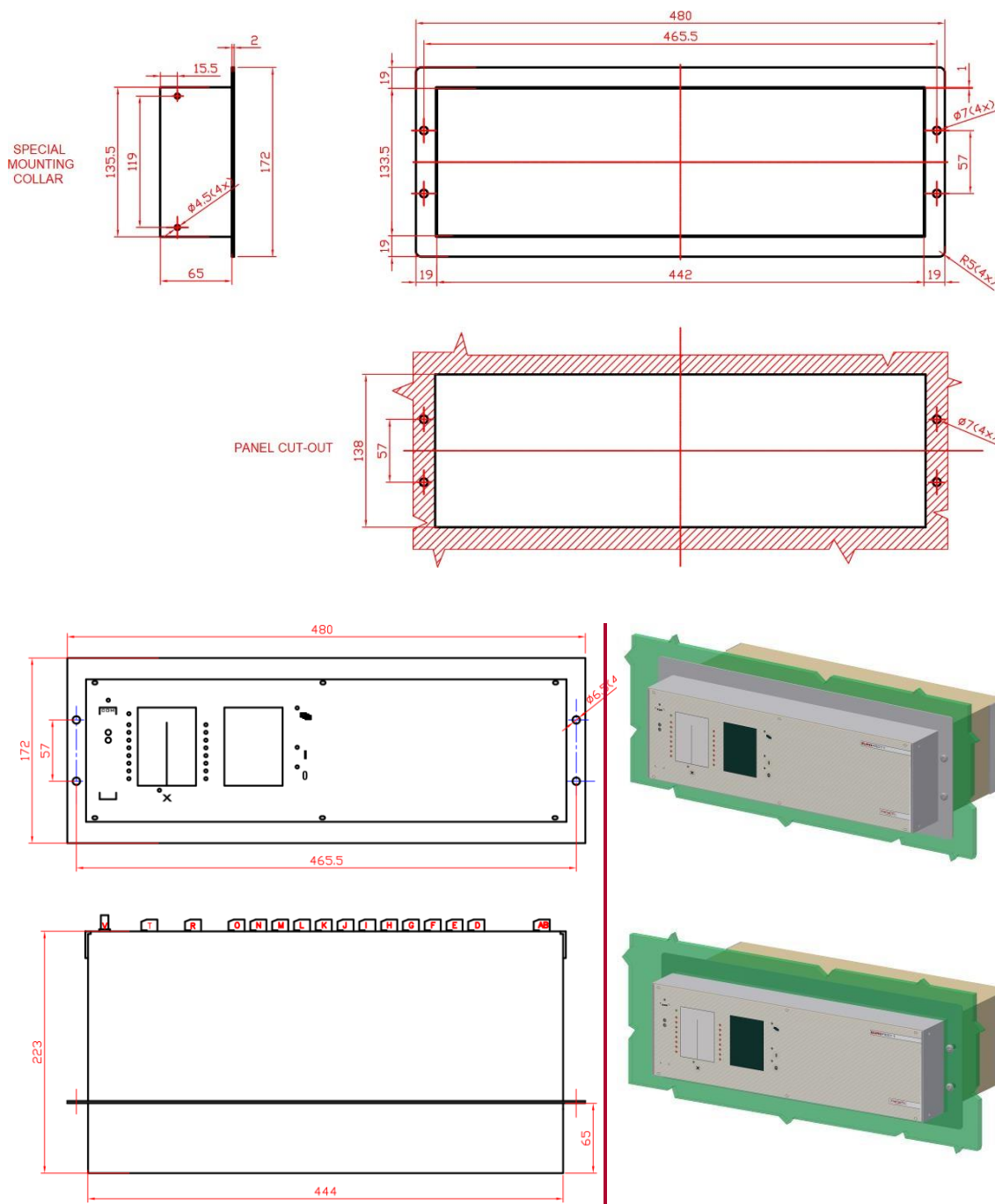

Figure 21-11 Dimensions for semi-flush mounting of 84 HP single rack with 3D illustration

1.3.23.3.2. Semi-flush mounting of 42 HP single rack

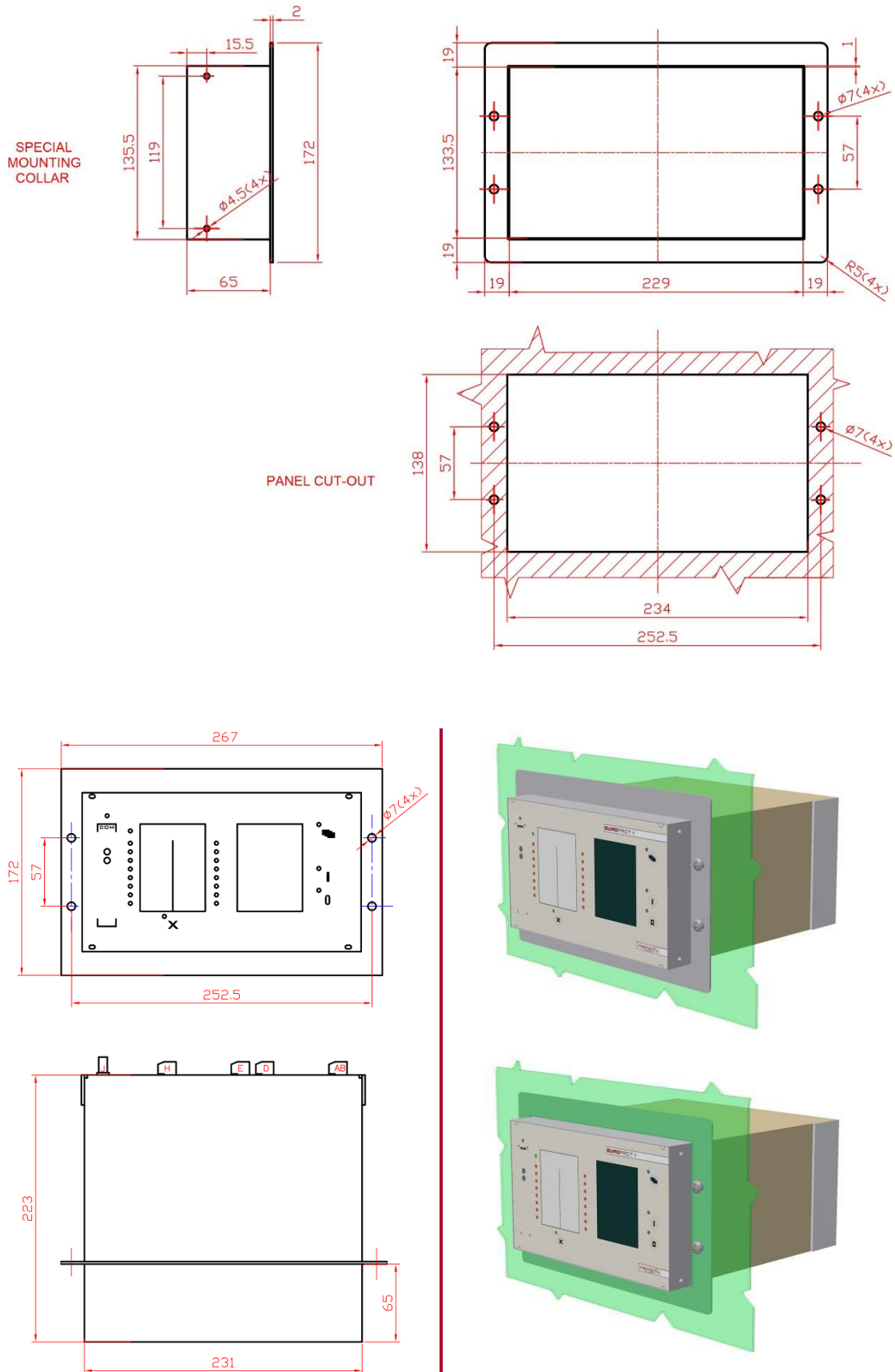
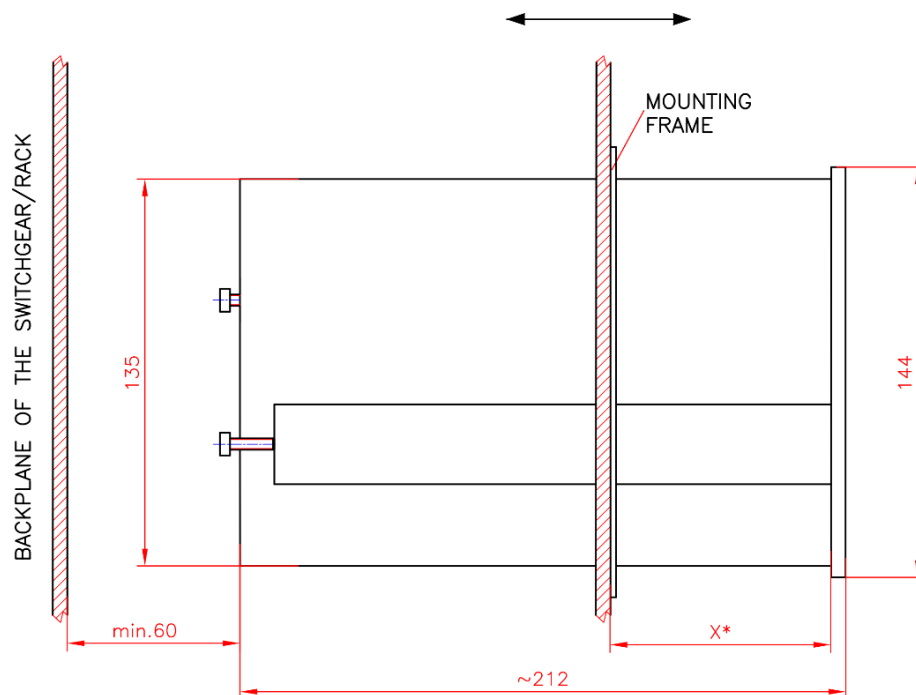

Figure 21-12 Dimensions for semi-flush mounting of 42 HP single rack with 3D illustration

1.3.23.3.3. Semi-flush mounting of 24 HP panel instrument case

The dimensions of the panel cut-out for this type of mounting method are the same as in case of flush mounting (138 mm x 138 mm). For semi flush mounting, it is enough to cut in two the fixing elements (with green colour in the 3D illustration below) and to make the assembly as shown in the pictures below.

Note that the IP54 front panel option cannot be utilized with this type of mounting.



*X: depending on the position of the cutting, the frame can be placed freely

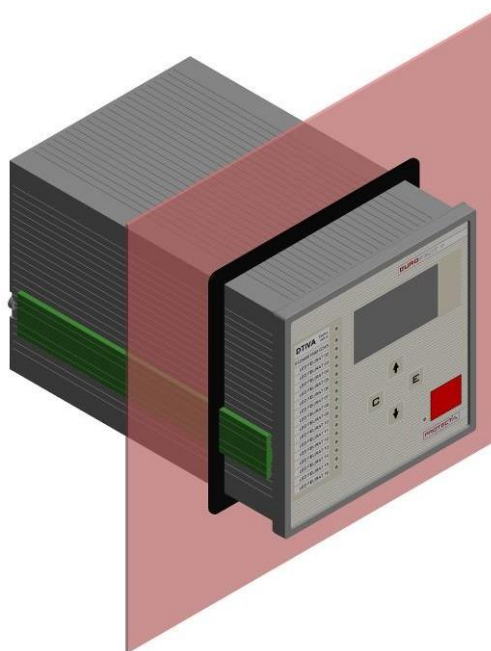

Figure 21-13 Dimensions for semi-flush mounting of 24 HP panel instrument case with 3D illustration

1.3.23.4. Wall mounting of 42 HP and 84 HP devices

Depending on the amount of the terminal contacts, it is possible to use both upper and lower terminals.

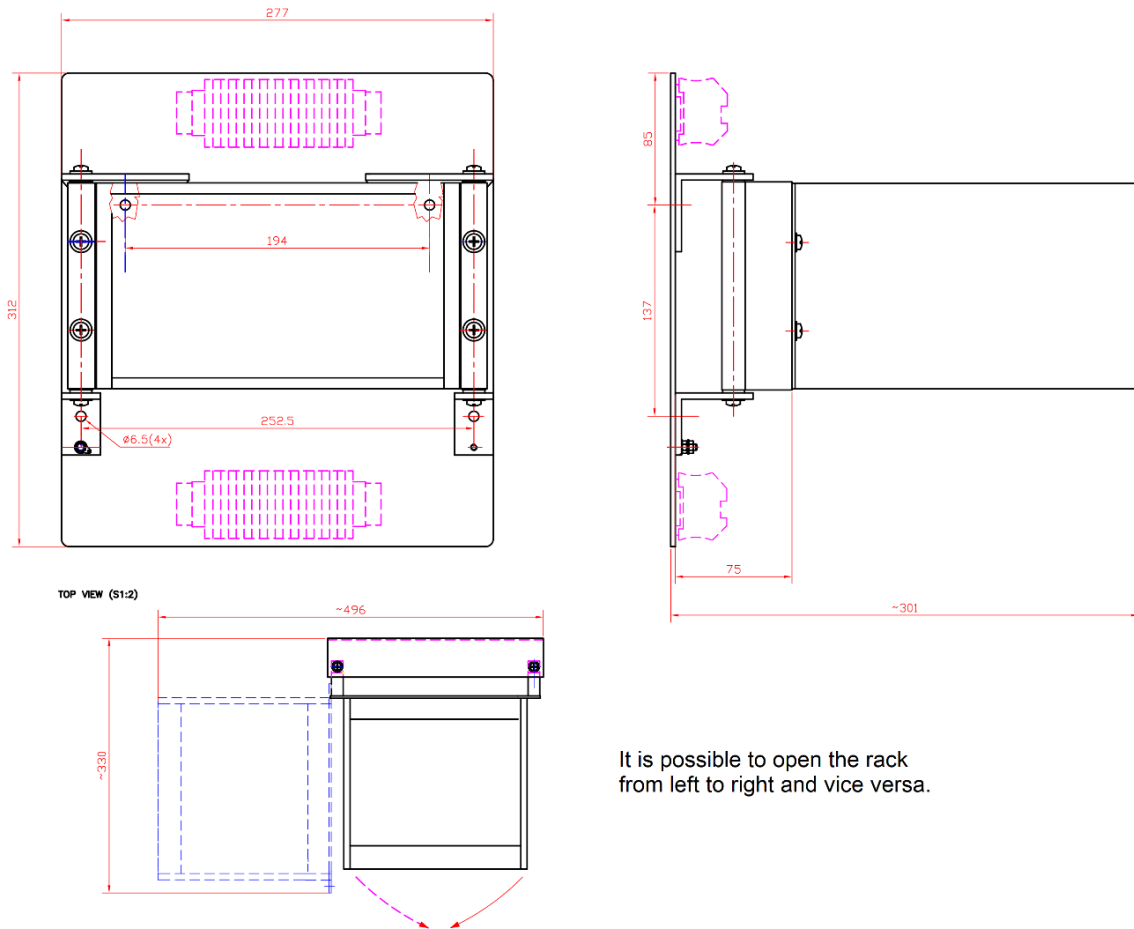

Figure 21-14 Dimensions for wall mounting of 42 HP devices (upper and lower terminals)

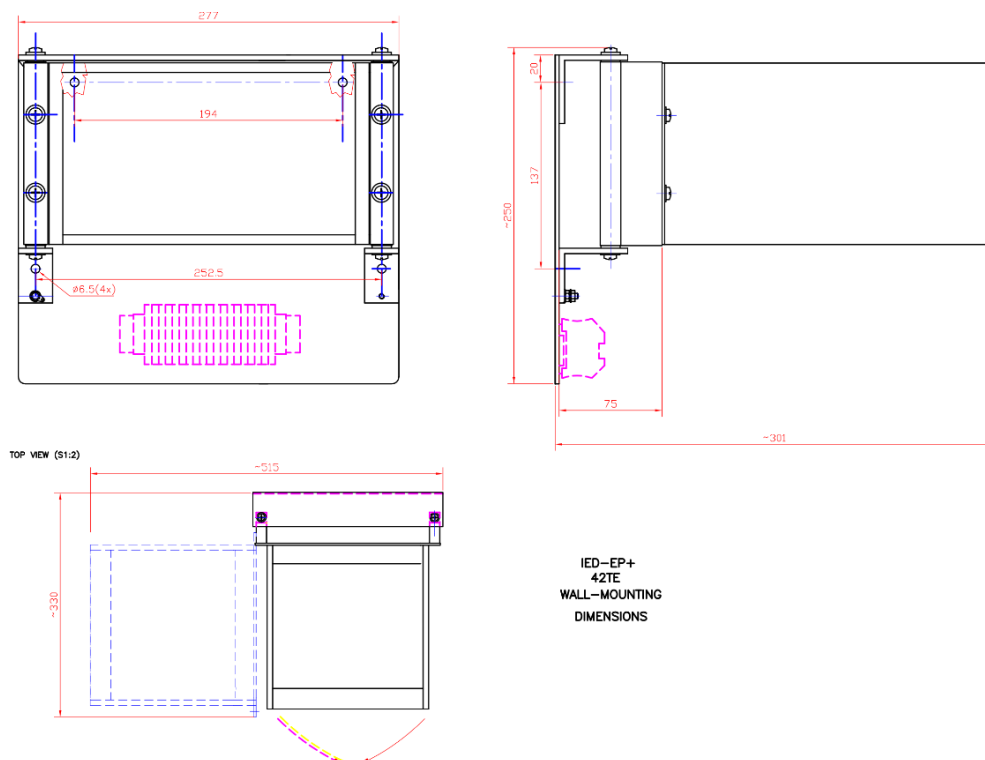

Figure 21-15 Dimensions for wall mounting of 42 HP devices (lower terminal only)

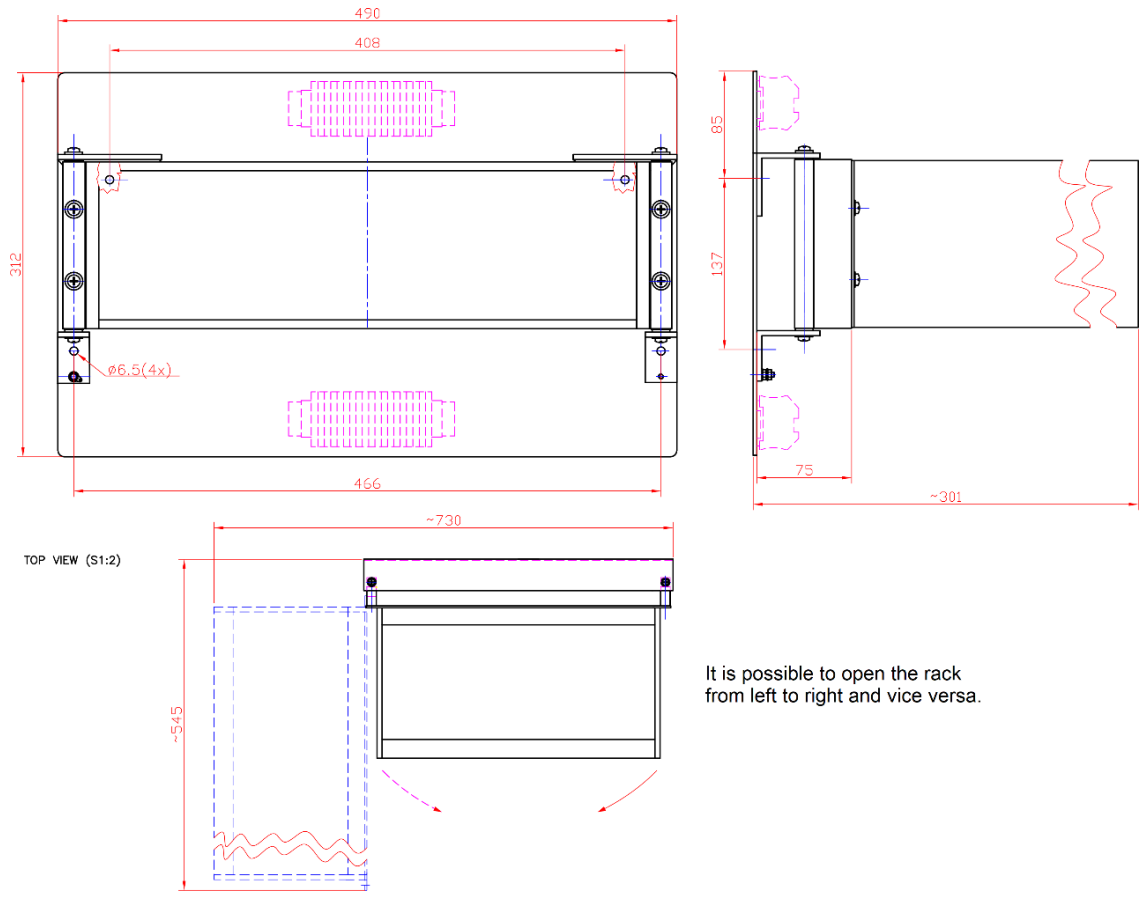

Figure 21-16 Dimensions for wall mounting of 84 HP devices (upper and lower terminals)

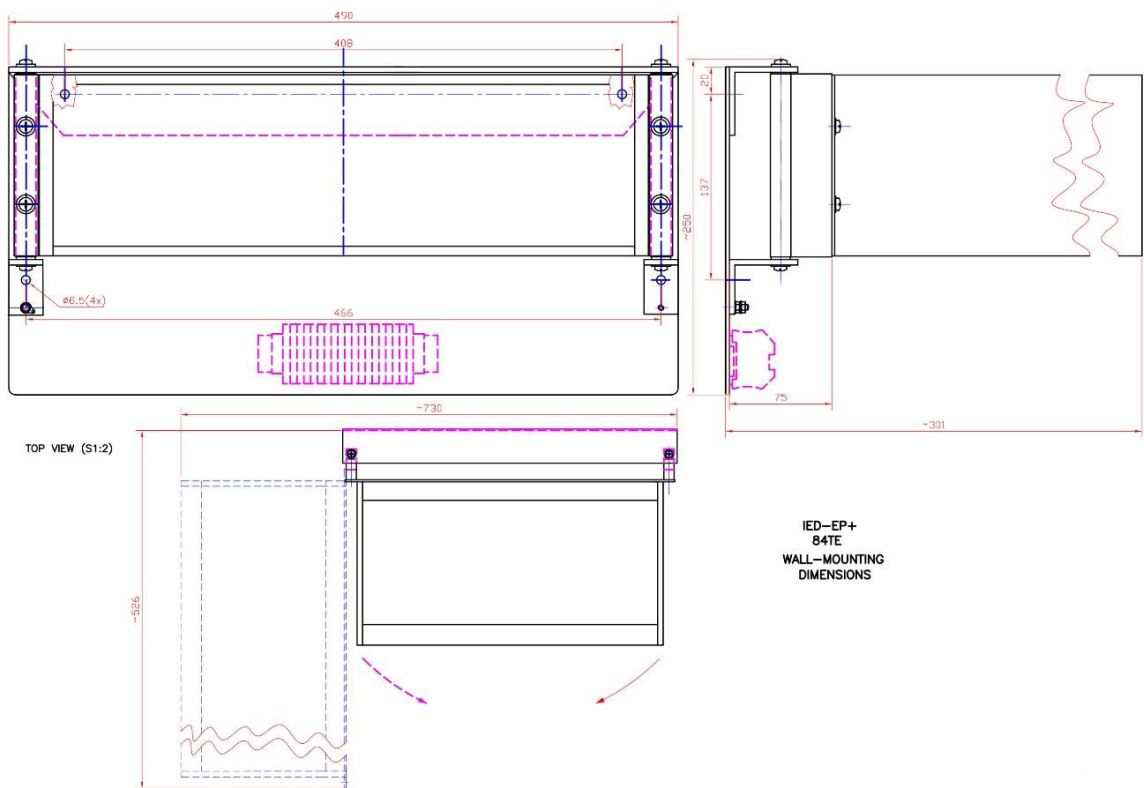

Figure 21-17 Dimensions for wall mounting of 84 HP devices (lower terminals only)

1.3.23.5. Din rail mounting of 24 HP panel instrument case

Note that the IP54 front panel option cannot be utilized with this type of mounting.

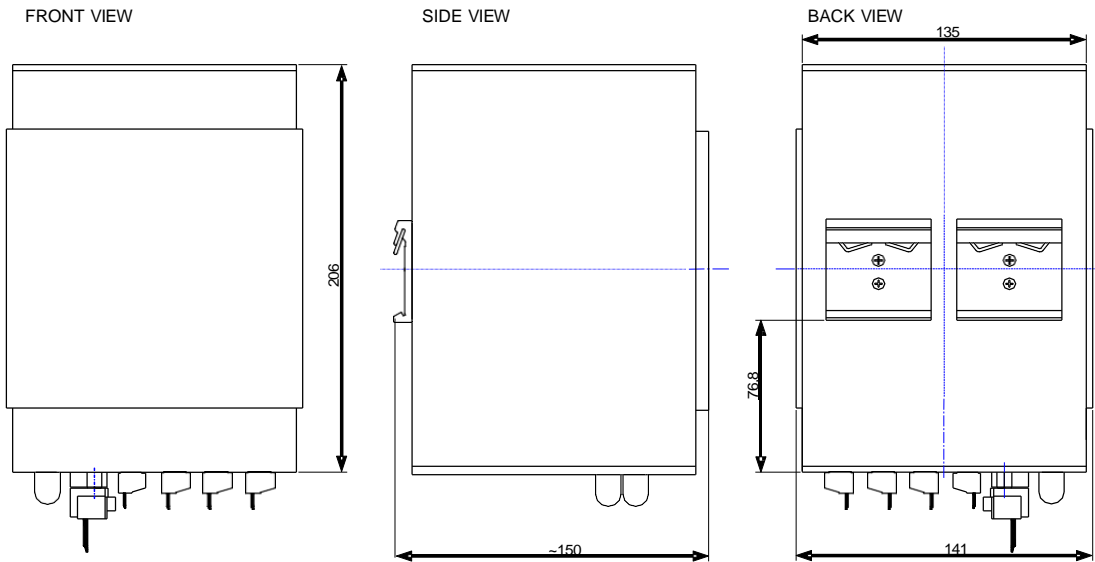

Figure 21-18 Dimensions for din rail mounting of 24 HP panel instrument case

1.3.23.6. IP54 rated mounting kit

The IP frame seen below provides IP54 protection from front side for 84HP and 42HP devices.

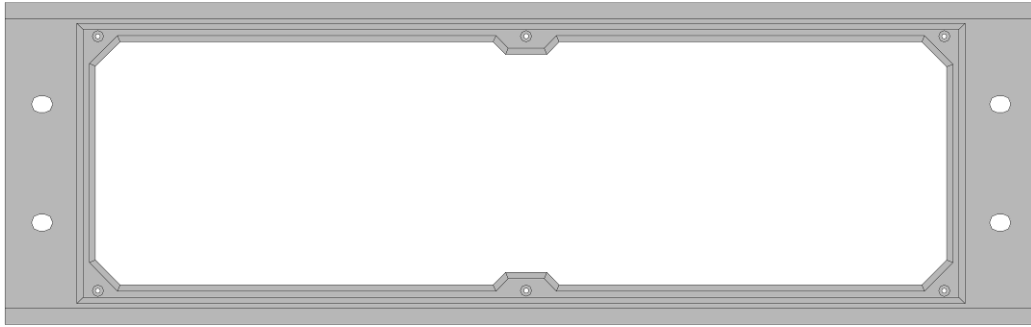

Figure 21-19 84 HP IP frame front view



Figure 21-20 42 HP IP frame front view

S24 devices

The S24 devices' front panel *does not differ from the normal front panel on the outside*, as there is IP54 gasket applied within the frame itself. Devices ordered with this option must be mounted by *flush mounting*; with other types of mountings (e.g. semi-flush), the IP54 protection is not guaranteed!

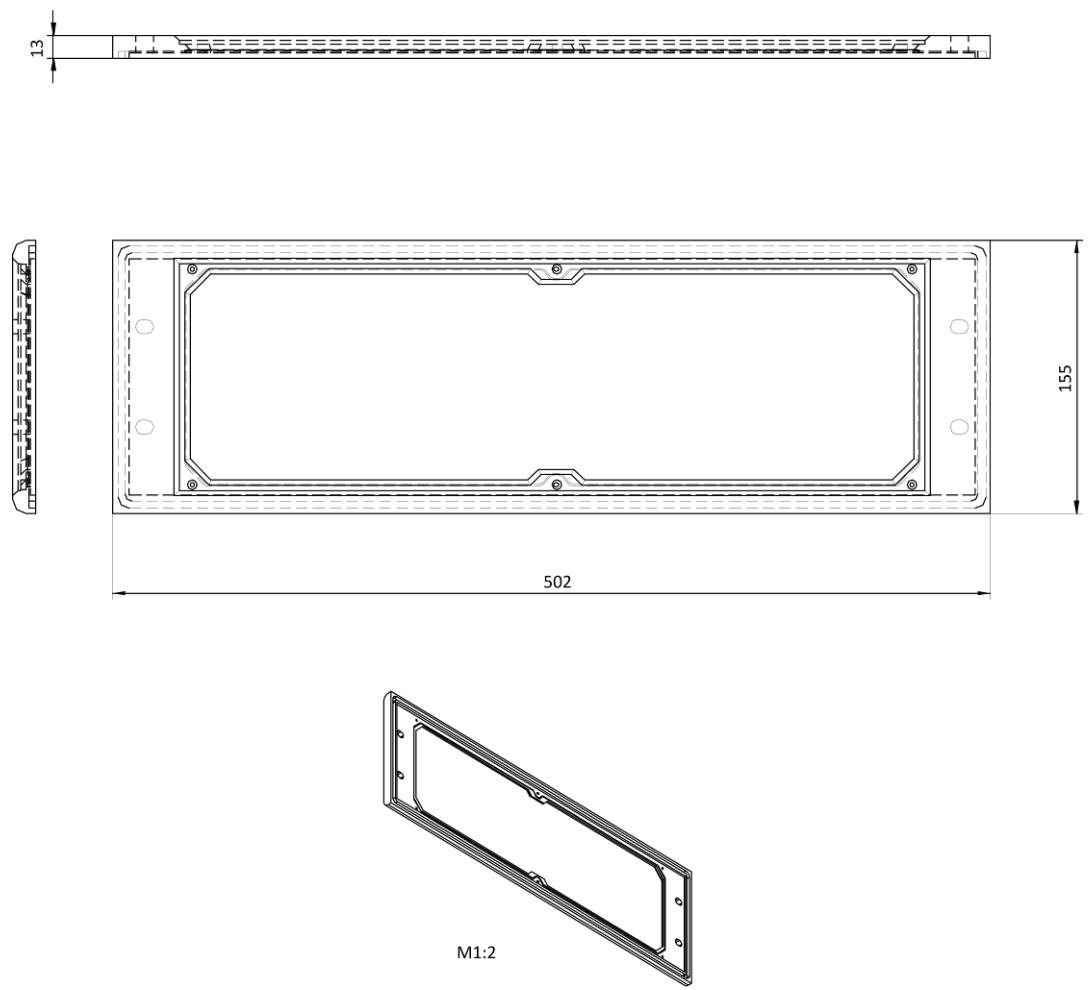

Figure 21-21: 84 HP IP frame dimensions

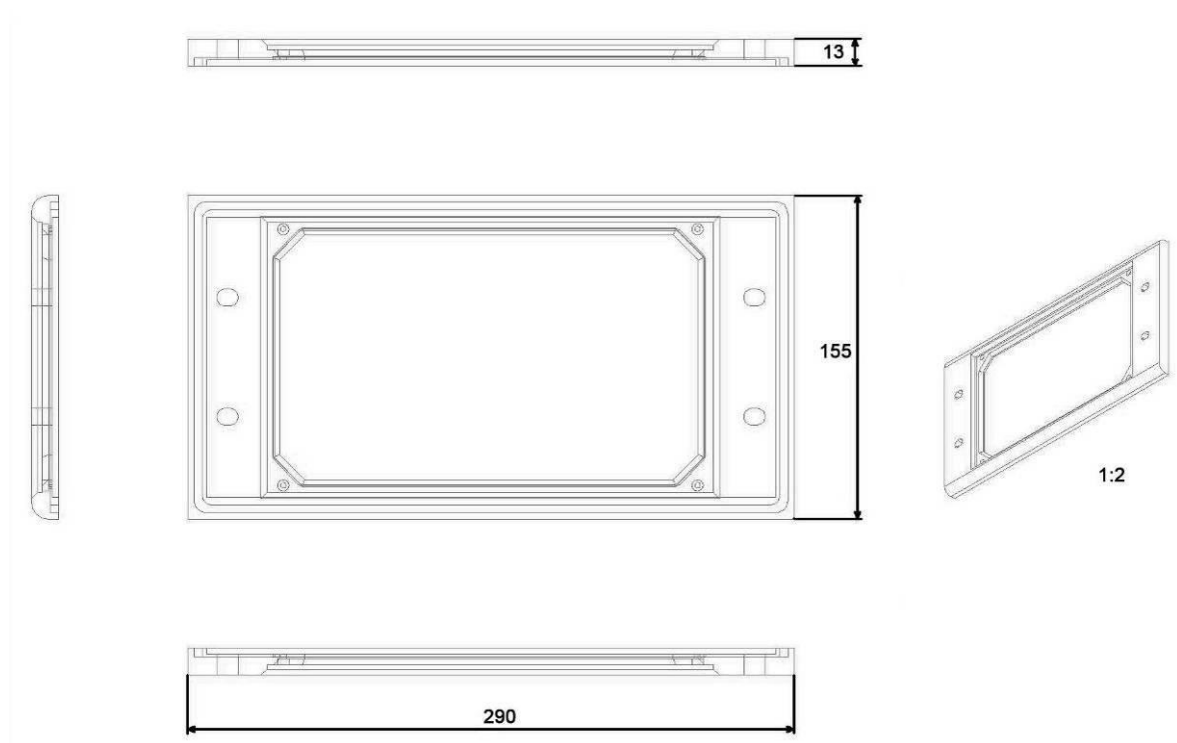

Figure 21-22 42 HP IP frame dimensions

1.3.23.7. Fold-down mounting

1.3.23.7.1. Fold-down mounting without terminals

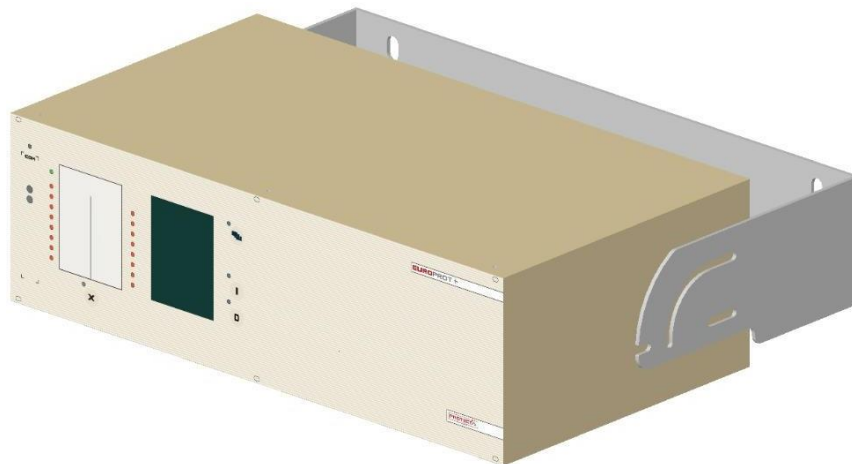
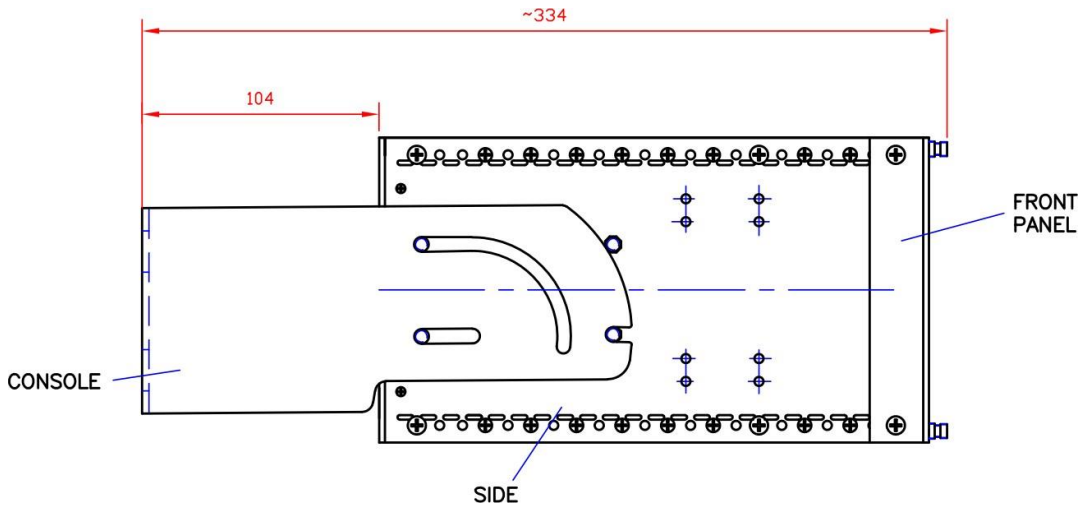
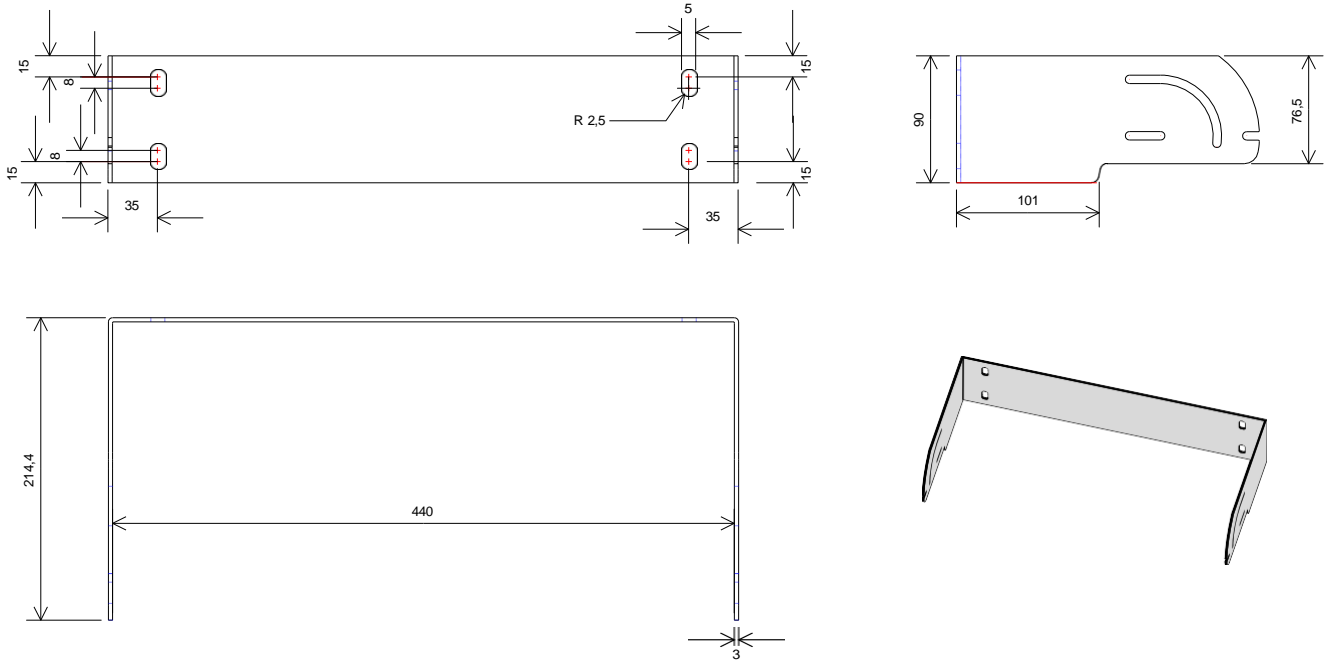

Figure 21-23 84 HP fold-down mounting

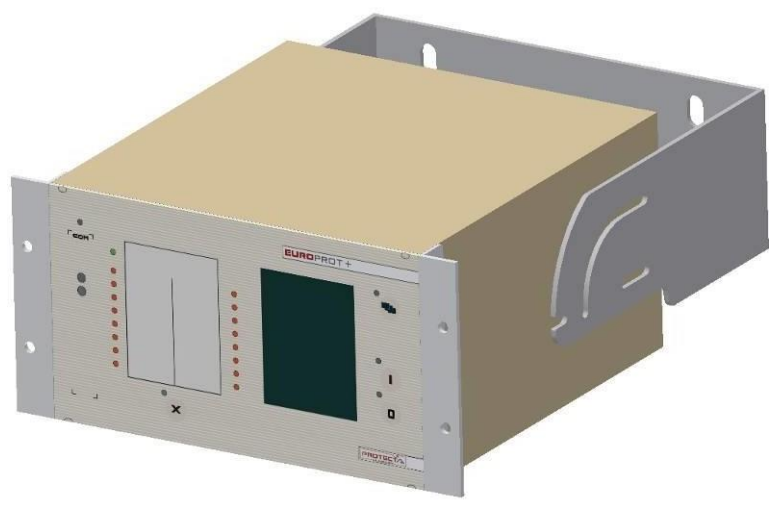
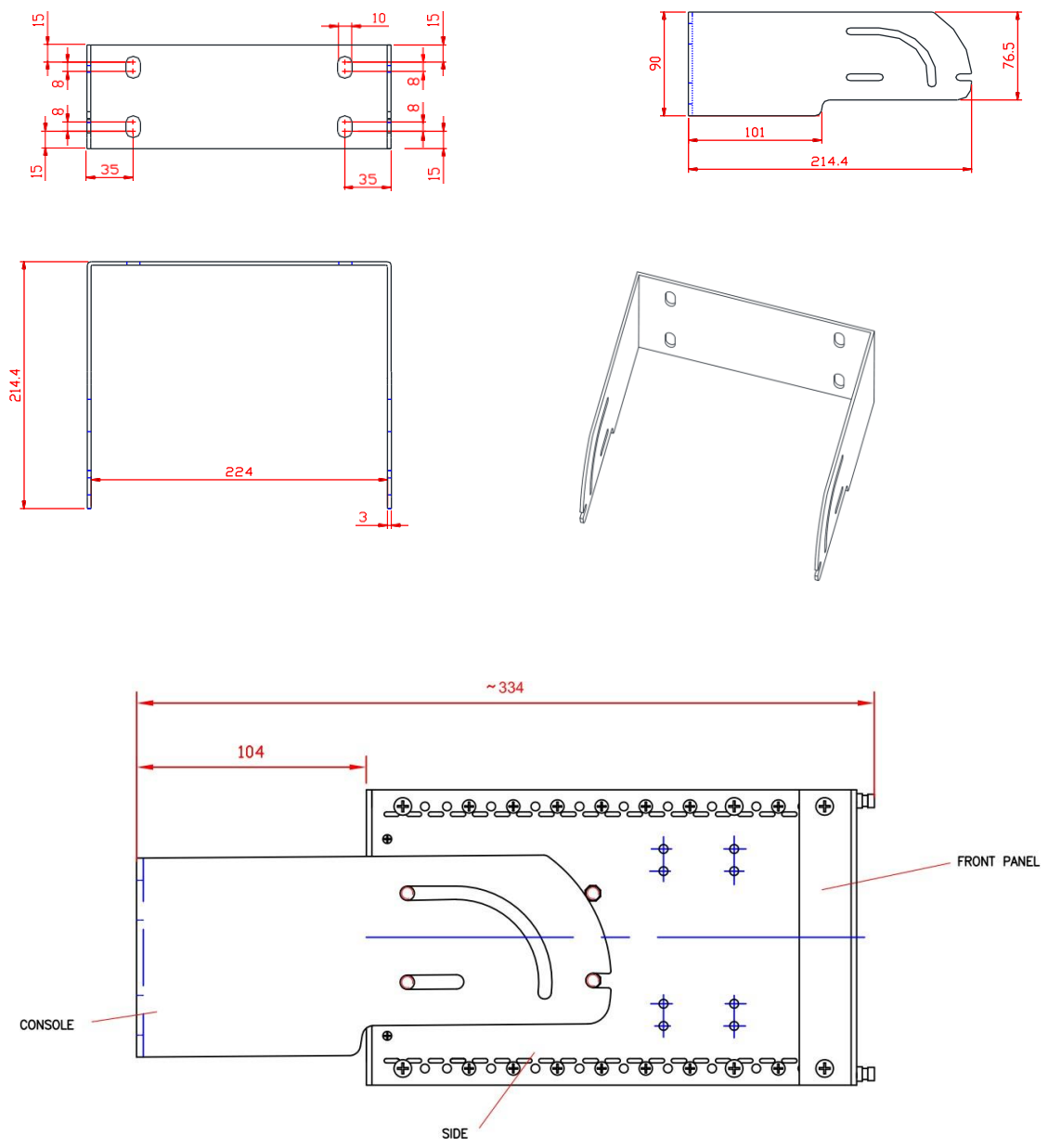

Figure 21-24 42 HP fold-down mounting

1.3.23.7.2. Fold-down mounting with terminals

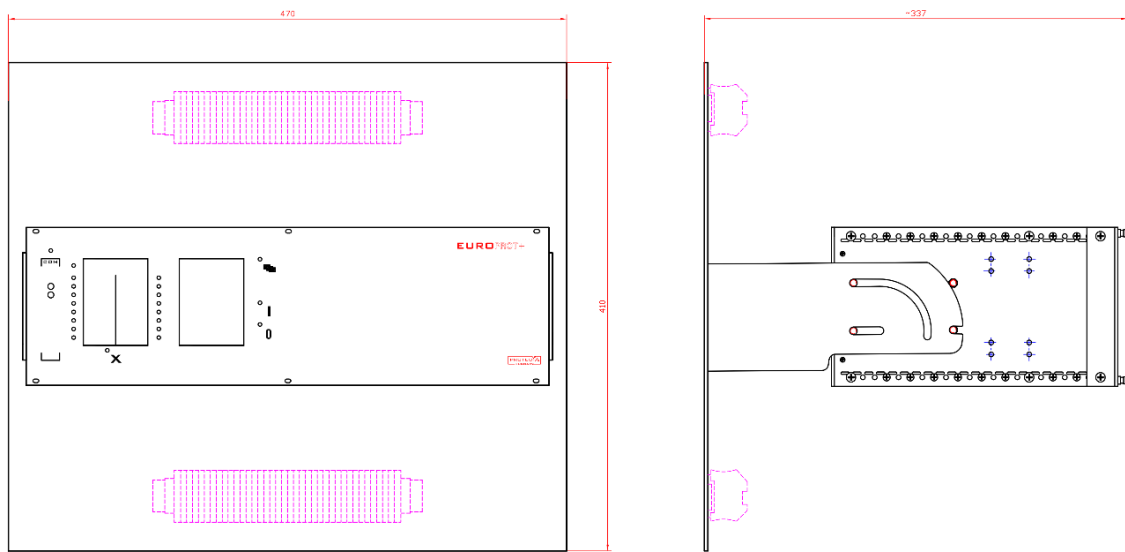

Figure 21-25 Fold-down mounting with terminals for 84HP devices

*fastening points are customized

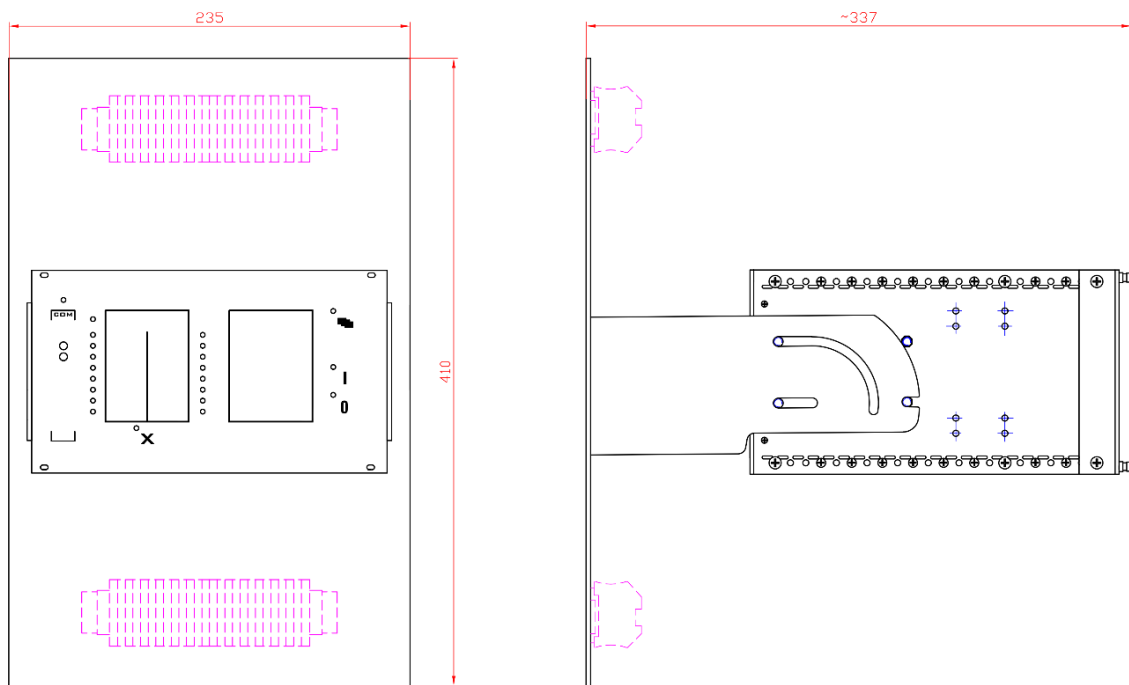
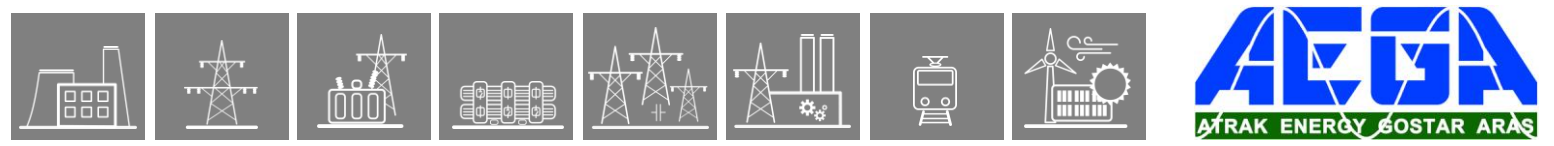

Figure 21-26 Fold-down mounting with terminals for 42HP devices



1.3.23.8. No mounting

“No mounting” means that the 84 HP and 42 HP devices do not have any mounting accessories on them.

This mounting method is only applicable if the device is for demonstration application.

For more information about this topic please contact our Application Team.
(application@protecta.hu)

IMPORTANT
 The dimensions of the cut-outs applicable for the remote HMI are depending on which previously mentioned mounting method is used (flush mounting, semi-flush mounting or rack mounting).

1.3.23.9. Remote HMI devices

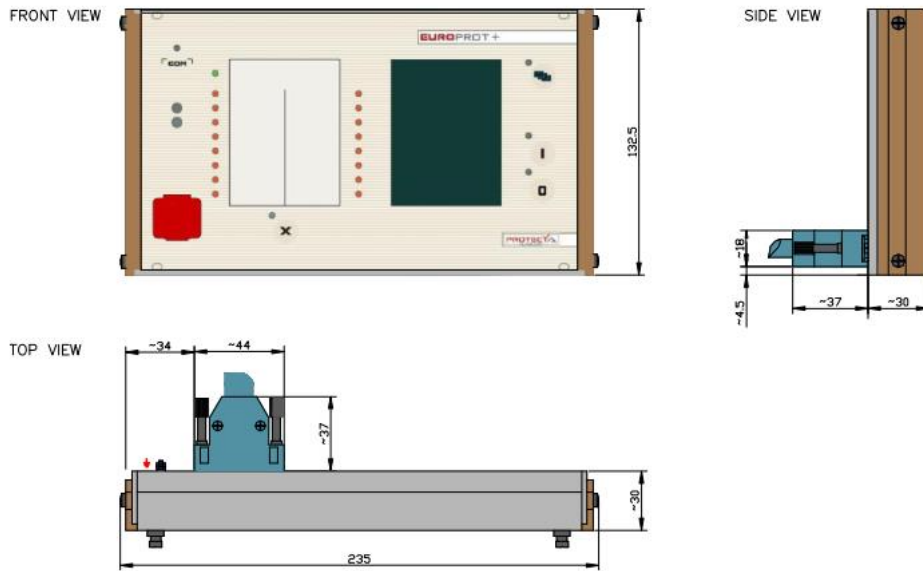

Figure 21-27 Dimensions for 42 HP wide remote HMI

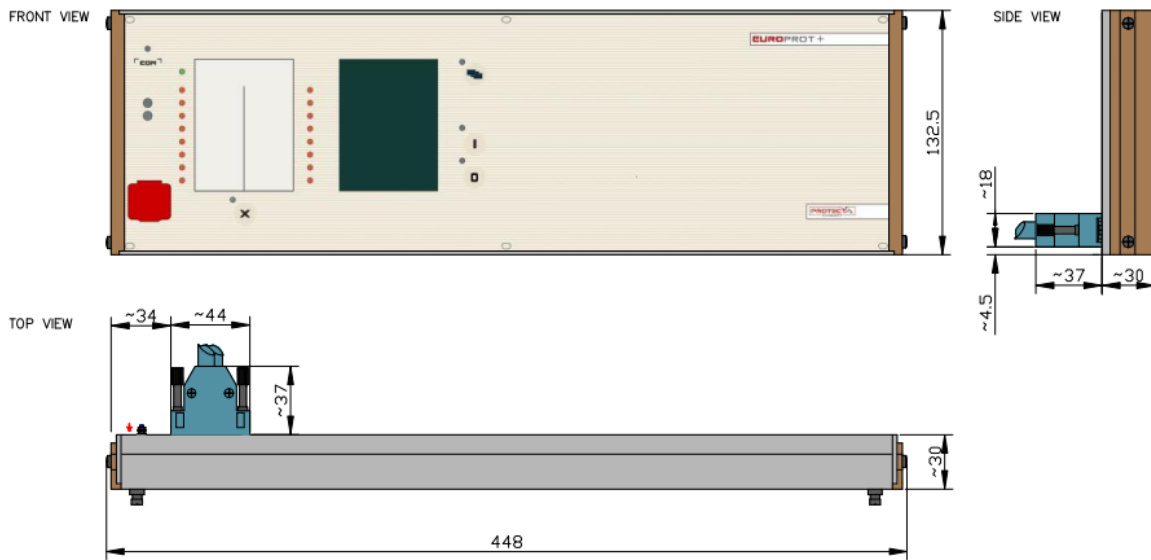
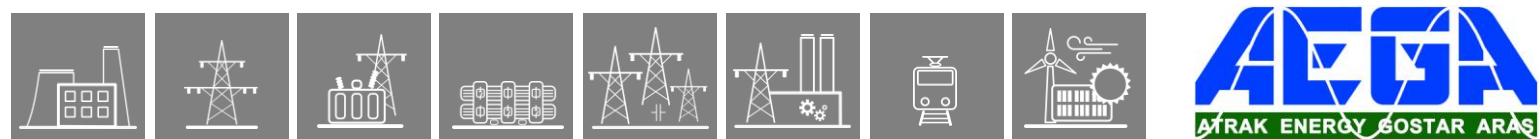

Figure 21-28 Dimensions for 84 HP wide remote HMI



1.3.24. Product availability (special and obsolete modules)

In this chapter you can read a list of the modules that have not regular availability for any reason (being obsolete or being used only in special configurations).

Special modules:

These modules can be ordered in case of special applications which are indicated for each module at its description in the previous chapters.

For more information about these devices please contact our Application Team. (application@protecta.hu)

Optional connectors:

The optional connectors are indicated at each module's description in the previous chapters. If a module is to be shipped with an optional connector, the issue must be discussed during ordering.

MODULE TYPE	COMMENT	DATE
CPU+/0001	Legacy CPU card, not recommended for new configurations. Replacement: CPU+1211	2013-06-12
CPU+/0002	Legacy CPU card, not recommended for new configurations. Replacement: CPU+1111	2013-06-12
CPU+/0003	Legacy CPU card, not recommended for new configurations. Replacement: CPU+1101	2013-06-12
CPU+/0004	Legacy CPU card, not recommended for new configurations. Replacement: CPU+1201	2013-06-12
CPU+/0005	Legacy CPU card, not recommended for new configurations. Replacement: CPU+1281	2013-06-12
CPU+/0006	Legacy CPU card, not recommended for new configurations. Replacement: CPU+1381	2013-06-12
CT+/1155	Available only for special configurations.	2013-06-12
CT+/5152	Available only for OGYD bay unit configurations.	2013-06-12
VT+/2215	Available only for special configurations.	2013-06-12
O12+/2101	Available only for demonstration applications.	2013-06-12
O12+/4201	Available only for demonstration applications.	2013-06-12
R4S+/01	Available only for special configurations.	2013-06-12
R4S+/16	Available only for special configurations.	2013-06-12
TRIP+/1101	Obsolete module. Not recommended for new designs.	2013-06-12
PS+/1602	Available only for special configurations.	2013-06-12
HMI+/2401	Obsolete module. Not recommended for new designs.	2014-10-06

HMI+/2404	Smart Line S24 special selection modules.	2014-10-06
HMI+/2504	Smart Line S24 special selection modules.	2014-10-06
COM+/8882	Available only for special configurations.	2014-10-06
CT+/1111	Available only for special configurations.	2014-10-06
CT+/2500	Available only for special configurations.	2014-10-06
CT+/5153	Available only for special configurations.	2014-10-06
VT+/2212	Available only for special configurations.	2014-10-06
R8+/01	Available only for special configurations.	2014-10-06
R8+/A1	Available only for special configurations.	2014-10-06
R8+/C0	Available only for special configurations.	2014-10-06
R8+/FF	Available only for special configurations.	2014-10-06
R12+/4400	Available only for special configurations.	2014-10-06
R16+/0101	Available only for special configurations.	2014-10-06
R16+/0001	Available only for special configurations.	2014-10-06
R16+/A001	Available only for special configurations.	2014-10-06
PS+/4401	Available only for special configurations.	2014-10-06
CT+/2500	Obsolete module. Not recommended for new designs. Replacement: CT+1500.	2015-02-13
PSTP+/2102	Available only for special configurations.	2015-06-23
PSTP+/4202	Available only for special configurations.	2015-06-23
CT+/5111	Available only for special configurations.	2015-12-08
CT+/0101	Available only for special configurations. DEFL earth fault protection only.	2018-03-19
INJ+/0015	Available only for special configurations.	2018-03-19
CT+/5155	Available only for special configurations.	2018-03-26
VT+/2246	Available only for special configurations.	2018-03-26
AIC+/0201	Obsolete module. Not recommended for new designs.	2018-03-26
CT+/5111	Obsolete module. Not recommended for new designs.	2018-03-27
VS+/0031	Obsolete module. Not recommended for new designs.	2018-05-25

R1T+/0001	Available only for special configurations. DMD.	2018-10-05
CT+/5253	Available only for special configurations.	2018-10-05
42 HP housing	The length of the 42 HP box has been reduced from 242 mm to 223 mm. For more information about the previous size of the 42 HP box please see the Figure 22-1.	2018-12-18
AIC+/0200	Obsolete module. Not recommended for new designs.	2019-04-08
PS+/1030	Available only for special configurations.	2020-05-07
PS+/1060	Available only for special configurations.	2020-05-07
HMI+/5001	Obsolete module. Not recommended for new designs.	2020-06-04
HMI+/5002	Obsolete module. Not recommended for new designs.	2020-06-04
HMI+/3502 (for 42HP)	Obsolete module. Not recommended for new designs.	2020-06-04
CT+/1515	Available only for special configurations.	2020-06-04
CT+/5115	Available only for special configurations.	2020-06-04
CT+/5116	Available only for special configurations.	2020-06-04
CT+/5154	Available only for special configurations.	2020-06-04
PSF+/1001	Available only for special configurations.	2020-06-04
RTD+/0200	Available only for special configurations.	2020-06-04
RTD+/1200	Available only for special configurations.	2020-06-04
R4MC+/01	Available only for special configurations.	2020-06-04
PS+/4301	Obsolete module. Not recommended for new designs.	2020-06-04
84 HP housing	The depth of the 84 HP box has been reduced from 242 mm to 223 mm. For more information about the previous size of the 84 HP box, see the Figure 22-1.	2021-04-01
HMI+/3501	Obsolete module. Not recommended for new designs.	2021-04-20
HMI+/3502	Obsolete module. Not recommended for new designs.	2021-04-20
HMI+/5701	Obsolete module. Not recommended for new designs.	2021-04-20
HMI+/5702	Obsolete module. Not recommended for new designs.	2021-04-20
COM+/1202	Obsolete module. Not recommended for new designs.	2021-04-20
COM+/1324	Obsolete module. Not recommended for new designs.	2021-04-29
VT+/2212	Obsolete module. Not recommended for new designs.	2021-05-06
CT+/5154	Obsolete module. Not recommended for new designs.	2021-05-06
O16+/2401	Obsolete module. Not recommended for new designs.	2022-03-22
O16+/4801	Obsolete module. Not recommended for new designs.	2022-03-22



O16+/1101	Obsolete module. Not recommended for new designs.	2022-03-22
O16+/2201	Obsolete module. Not recommended for new designs.	2022-03-22

1.3.24.1. Previous 42HP and 84HP device housings

As of 2021. Q2, not only the 42HP, but the 84HP devices are shipped with shorter racks as well. Note that this is the only difference between the new and old housings. The new racks are shorter by 19 mm from the front, thus their depth is 223 mm instead of 242 mm.

The mounting methods described in Chapter 21 are valid for the previous racks as well, keeping in mind that the depth of the device is 19 mm bigger than that of the drawings. As an example, see the previous drawing of the flush mounting for 42HP and 84HP devices in Figure 22-1. As a comparison, the new, shorter rack is also drawn in light blue.

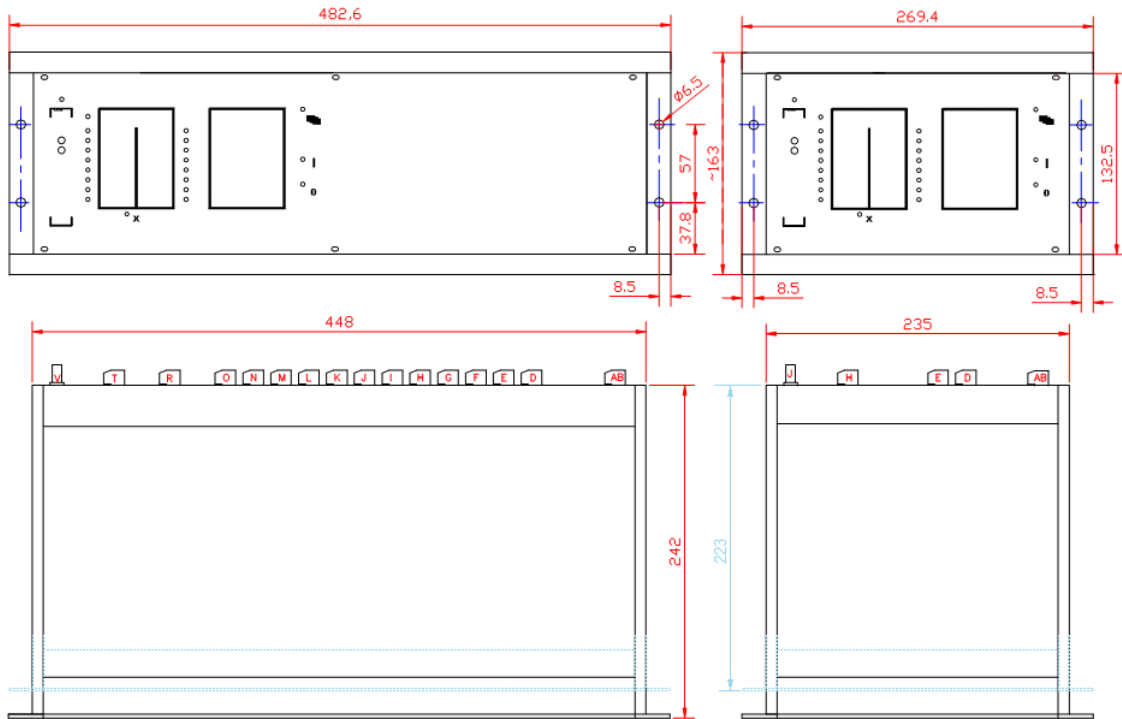

Figure 22-1 Dimensions for flush mounting of the previous 84HP and 42HP single rack, including the new (shorter) rack dimensions as well.

1.3.25. Remote I/O (RIO) server description

1.3.25.1. Introduction

Remote I/O (RIO) server is an IED, which provides remote binary inputs and outputs far from an EuroProt+ protection device.



Figure 1-1 Remote I/O device



Figure 1-2 Front view and rear view with fastening for mounting rail

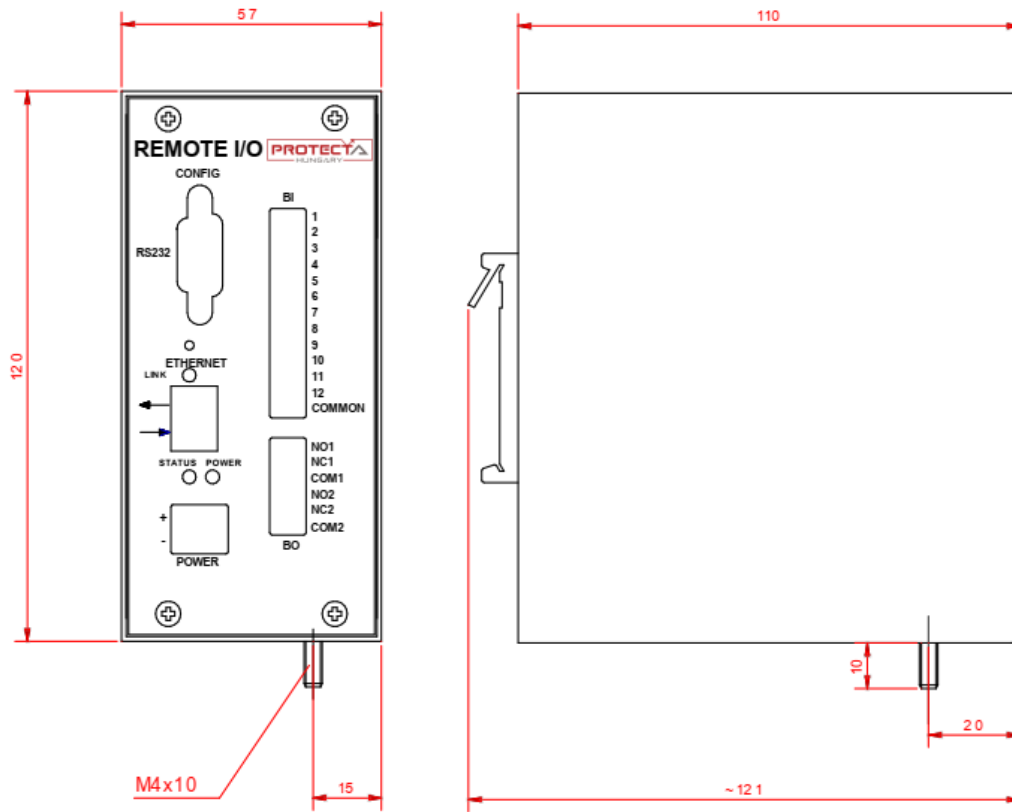

Figure 1-3 Remote I/O dimensions

1.3.25.2. Application

1.3.25.2.1. Connectors, LEDs

The connectors of the device are illustrated in the following figure.

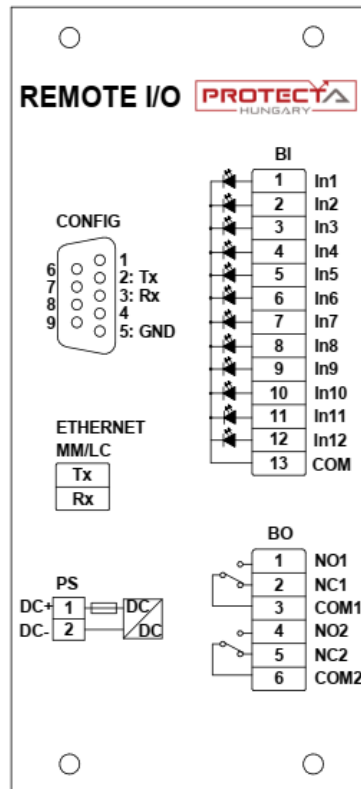

Figure 2-1 Connectors of the device

The RIO server has three LED indicators:

- **LINK:** located at the Ethernet connector; it shows active communication (green color)
- **POWER:** located above the power connector; it lights up if the device is operating (green color)
- **STATUS:** located also above the power connector. The behavior and color of this LED shows different situations:
 - Blinking **red**: there are no clients connected
 - Blinking alternatively **red-green**: the server has one client connected
 - Blinking **green**: two or more clients are connected

1.3.25.2.2. Wiring, usage

The device communicates with the EP+ device using the MODBUS/TCP protocol, via either of the COM+/1202, COM+/1324, COM+/1335, COM+/6603 or COM+/6663 modules.

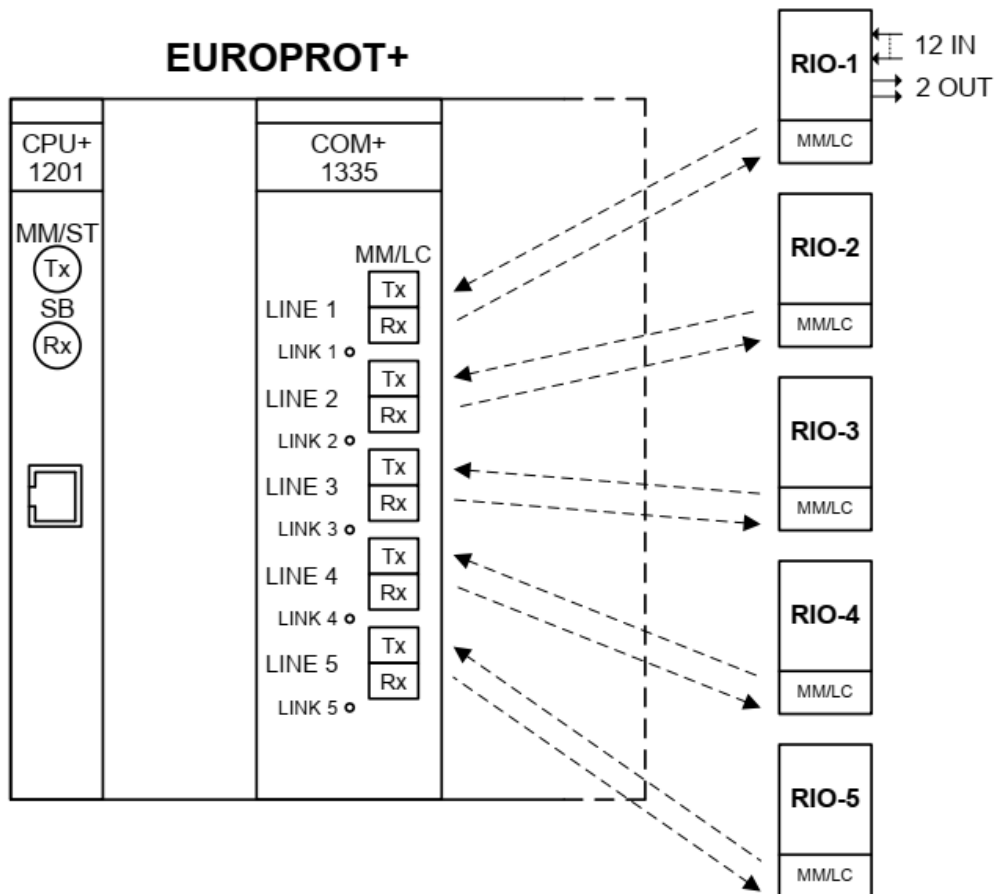

Figure 2-2 Wiring of the Remote I/O-s

The RIO inputs and outputs appear among the other binary inputs and outputs of the EuroProt+ device, and they can be utilized the same way.

1.3.25.3. Sub-modules

The RIO server consists of two mixed function modules:

- SCPU/PS: combination of a CPU and power supply module
- SO12/R2: binary I/O module with 12 inputs and 2 relay outputs

1.3.25.3.1. SCPU/PS sub-module

The SCPU/PS module contains all the control, communication and the power supply functions of the device.

1.3.25.3.1.1. CPU

Table 3-1 Technical data of the RIO CPU

CPU TYPE	ETHERNET INTERFACE	SERVICE PORT
SCPU+0011	MM/LC 1300 nm, 50/62,5/125 µm connector, 100Base-FX	RS232*

*The service port labeled "CONFIG" is only for factory usage

1.3.25.3.1.2. Power supply, external MCB

Table 3-2 Technical data of the RIO power supply

PS TYPE	INPUT VOLTAGE	NOMINAL POWER	INPUT VOLTAGE INTERRUPTION TIME	INRUSH CURRENT (< 0.1 s)	CONNECTOR TYPE
PS+1101	65-180 V DC	9 W	min. 140 ms @ 110 V DC input voltage	< 10 A	Weidmüller BLA 2/180
PS+2301	176 – 264 V DC 160 – 250 V AC	9 W	min. 50 ms @ 230 V AC input voltage	< 10 A	Weidmüller BLA 2/180

The power supply must be protected by an **external midget circuit breaker**. Note that it is not part of the RIO device:

- Characteristics: **6A C**

1.3.25.3.2. SO12/R2 sub-module

The SO12/R2 module contains 12 binary inputs in one grounding group, and 2 relay outputs with dry contacts.

1.3.25.3.2.1. Binary inputs

Main features:

- Digitally filtered per channel
- Current drain approx.: 2 mA per channel

Table 3-3 Technical data of the binary inputs

BI TYPE	CHANNEL NUMBER	TIME SYNC.	RATED VOLTAGE	THERMAL WITHSTAND VOLTAGE	CLAMP VOLTAGE	CONNECTOR TYPE
SO12+4801	12	-	48 V	72 V	falling $0.71 U_N$ rising $0.76 U_N$	Weidmüller BL 3.5/13/180
SO12+1101	12	-	110 V	250 V	falling $0.7 U_N$ rising $0.73 U_N$	Weidmüller BL 3.5/13/180

Thermal withstand voltage: continuous with 60 % of the input channels energized.

1.3.25.3.2.2. Binary outputs

Main features:

- Breaking capacity, (L/R = 40 ms) at 220 V DC: 0.2 A
- Breaking capacity, (L/R = 40 ms) at 110 V DC: 0.3 A

Table 3-4 Technical data of the relay outputs

BO TYPE	RATED VOLTAGE	CONTINUOUS CARRY	CONTACT VERSIONS	GROUP ISOLATION	CONNECTOR TYPE
R2+0001	250 V AC/DC	6 A	CO	2 independent	Weidmüller BL 3.5/6/180



1.3.25.4. General data

- Storage temperature: - 40 °C ... + 70 °C
- Operation temperature: - 20 °C ... + 55 °C
- Humidity: 10 % ... 93 %
- Altitude: up to 2000 m
- Atmospheric pressure: 86 ... 106 kPa

1.3.25.4.1. Standard conformance

- Electrostatic discharge immunity (ESD), IEC-EN 60255-26:2013, Level 4
 - Test voltages: 15 kV air discharge, 8 kV contact discharge
- Radiated, radio-frequency, electromagnetic field immunity, IEC-EN 60255-26:2013 Level 3
 - Test field strength: 10 V/m
- Electrical fast transient/burst immunity (EFT/B), IEC-EN 60255-26:2013, Level 4
 - Test voltage: 4 kV
- Surge immunity test, IEC-EN 60255-26:2013
 - Test voltages: 2 kV line-to-earth, 1 kV line-to-line
- Immunity to conducted disturbances, induced by radio-frequency fields, IEC-EN 60255-26:2013, Level 3
 - Test voltage: 10 V
- Damped oscillatory wave immunity test, IEC-EN 60255-26:2013
 - Test frequency: 1 MHz
 - Test voltage: 2.5 kV in common mode, 1 kV in differential mode
- Voltage dips, short interruptions and voltage variations immunity, IEC-EN 60255-26:2013
 - Voltage dips: 40 % (200 ms), 70 % (500 ms), 80 % (5000 ms)
- Ripple on d.c. input power port immunity, IEC-EN 60255-26:2013
 - Level 4, 15 % of rated d.c. value
- Power frequency magnetic field immunity test, IEC-EN 60255-26:2013, Level 5
 - Test field strength: 100 A/m continuous, 1000 A/m for 3 s
- Power frequency immunity test on the binary inputs, IEC-EN 60255-26:2013, Class A
 - Test voltages: 300 V in common mode, 150 V in differential mode
- Insulation tests, IEC-EN 60255-27:2013
 - Impulse voltage test
 - Test levels: 5 kV (1 kV for transducer and temperature measuring inputs)
 - Dielectric test
 - Test levels: 2 kV AC 50 Hz (0.705 kV DC for transducer inputs)
 - Insulation resistance
 - Insulation resistance > 15 GΩ
- Radiated emission, IEC-EN 60255-26:2013
Limits:
 - 30 MHz to 230 MHz: 50 dB(μV/m) quasi peak, 3 m
 - 230 MHz to 1 000 MHz: 57 dB(μV/m) quasi peak, 3 m
 - 1 GHz to 3 GHz: 76 dB(μV/m) peak, 3 m
 - 3 GHz to 6 GHz: 80 dB(μV/m) peak, 3 m
- Conducted emission, IEC-EN 60255-26:2013
Limits:
 - 0,15 MHz to 0,50 MHz: 79 dB(μV) quasi peak, 66 dB(μV) average
 - 0,5 MHz - 30 MHz: 73 dB(μV) quasi peak, 60 dB(μV) average
- Vibration, shock, bump and seismic tests on measuring relays and protection equipment
 - Vibration tests (sinusoidal), Class I, IEC 60255-21-1:1988
 - Shock and bump tests, Class I, IEC 60255-21-2:1988
 - Seismic tests, Class I, IEC 60255-21-3:1993

1.3.25.5. Mechanical data

1.3.25.5.1. General mechanical data

- Construction
 - Painted steel surface
- IP protection:
 - IP2x
- Size:
 - See Figure 1-3 for the device dimensions
- Weight:
 - 0.7 kg

1.3.25.5.2. Connectors

Table 5-1 Connectors on the RIO

CONNECTOR NAME	CONNECTOR TYPE	STRIP LENGTH [MM]	CONDUCTOR AREA [MM ²]	CONDUCTOR DIAMETER [MM]	TIGHTENING TORQUE [Nm]	MINIMUM BEND RADIUS*
BLA	Weidmüller BLA 2/180	7	0.2 – 1.5 solid: 0.2 – 2.5	0.5 – 1.4 solid: 0.5 – 1.8	0.4 – 0.5	3 × OD**
BL 3.5	Weidmüller BL 3.5/6/180 BL 3.5/13/180	6	0.2 – 1.5	0.5 – 1.4	0.2 – 0.25	3 × OD**
PE FASTON TERMINAL	TE Connectivity 6.3x0.8	7	min. 4	min. 2.3	-	3 × OD**

* Bend radius is measured along the inside curve of the wire or wire bundles.

** OD is the outer diameter of the wire or cable, including insulation.

The tightening torque of the screw for protective earth connection must be approx. 5 Nm.

During the installation, make sure that the shortest possible length for PE (Protective Earth) cable.

The minimum distance between the device and its wire channel must be at least 3 cm.

1.3.26. Technical notes on EOB interoperability

1.3.26.1. Description

We experienced some interoperability issues regarding front panel communication with EP+ devices. The link establishment procedure of the ethernet communication become unstable with certain type of NICs (Network Interface Card) of network devices. Network devices with 10/100Base-T speed support has no limitation but devices with 1000Base-T (called gigabit) may cause this link establishment failure. In this case the operating system periodically signals that interface is connected, then disconnected, then connected etc.

1.3.26.2. EOB Troubleshooting

- force NIC speed and mode to 10Base-T Full-duplex (setting method may depend on Your PC hardware configuration) on Your PC. Local Area Network settings can be found at:
 - WindowsXP: Control Panel/Network Connections/Local Area Connection
 - Windows 7: Control Panel\All Control Panel Items\Network and Sharing Center

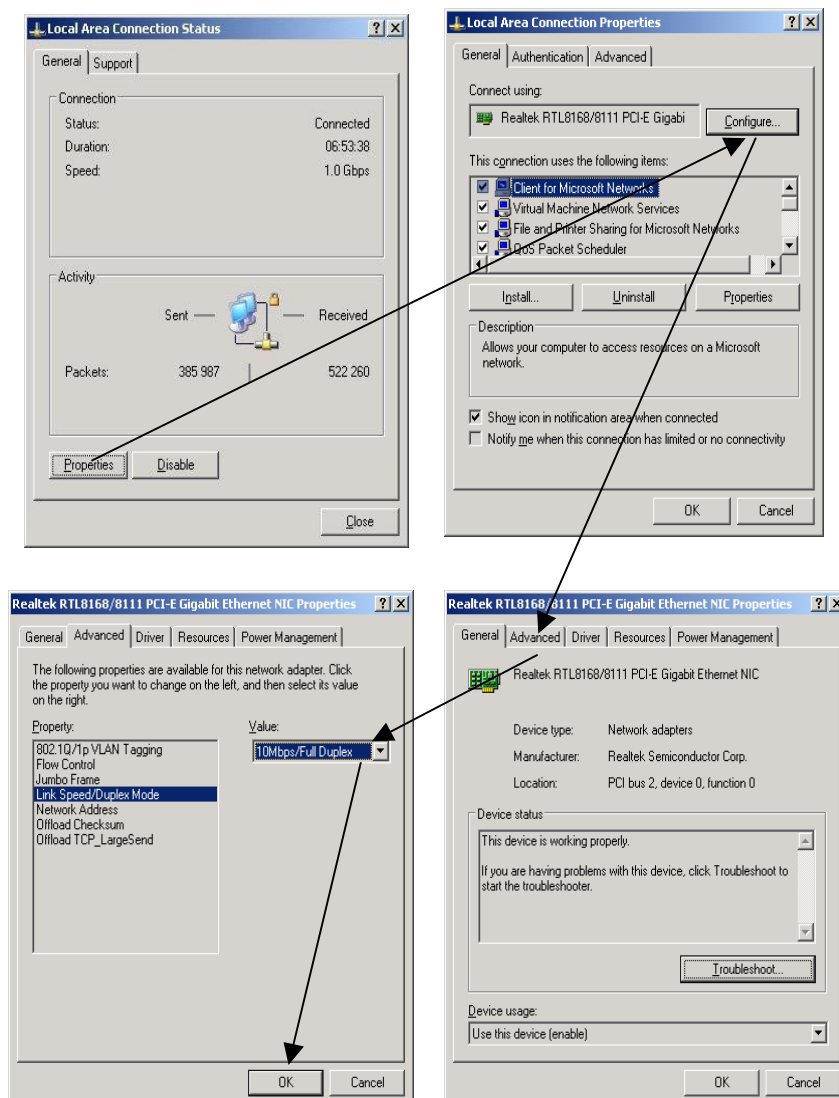

1.3.26.3. Workaround

- using station bus interface connector at the front panel of the CPU card
 - if the device equipped with 100Base-Fx station bus interface then You can connect Your computer via a third-party media converter unit
 - if the device equipped with 10/100Base-Tx station bus interface (RJ45) then connect Your computer directly to the EP+ via a crossed CATx cable

Service computer

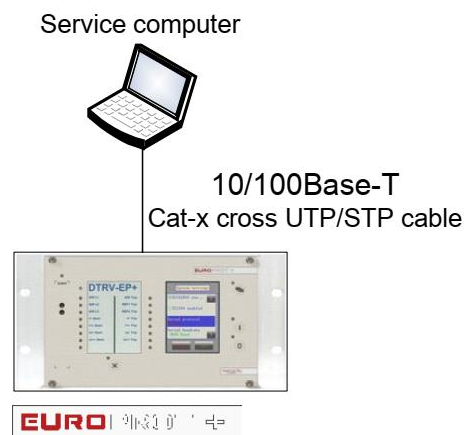

- using EOB at the HMI:
 - in case of unstable link with Your PC apply a third-party external 10/100Base-T switch with one port connected via EOB to the EP+ and other port connected to Your PC via a CATx cable.

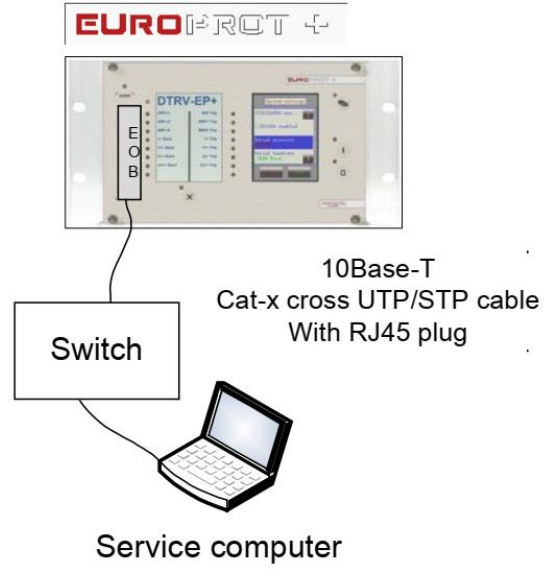

1.3.26.4. Further details

For getting started guide and IP configuration download: http://www.protecta.hu/epp-prelim/QuickStart/Quick_Start_Guide_V1.0.pdf

1.3.27. EP+ Installation manual

USED SYMBOLS

Symbols on devices:



Test voltage: 2 kV



Protective conductor terminal



Do not dispose of this device

Symbols in this document:



Caution, risk of electric shock



Caution, hot surface



Caution, refer to the documentation



Do not dispose of this device

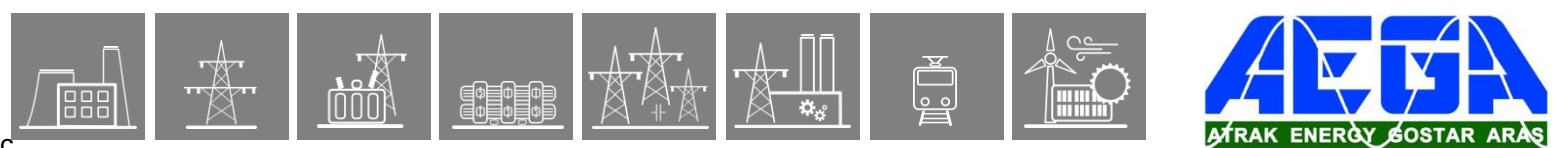

1.3.27.1. Introduction

This manual is intended to provide instruction for proper device installation, which includes mechanical mounting and electrical wiring. Furthermore, the information provided here will strongly support commissioning, maintenance, and deinstallation work as well. This document's targeted user groups are skilled electrical professionals executing installation works and commissioning with EuroProt+ devices.

Given that the EuroProt+ product family has a modular design, the instructions provided here can cover all configurations. Therefore, this manual shall be used in conjunction with the "EuroProt+ Hardware description" document, which includes essential information about all hardware components of the product.

1.3.27.2. Equipment handling

1.3.27.2.1. Unpacking

Inspect the package for transport damages. Carefully remove the packing material without applying excessive force.

1.3.27.2.2. Visual inspection

Identify the product by reading the order code. This can be found on the device nameplate located mostly on the right side of the device in the top right corner and shall be identical to your order.

Picture 2-2 Device nameplate



The protection device may have loose items packed in a different box based on the configuration. Check, that these items are also included in the shipment.

Visually inspect all unpacked items for damages, water ingress, or any sign of external impact. If you discover any transport damage, please notify Protecta Ltd. first and do not start any further work on the equipment.

1.3.27.2.3. Storage

If temporary storage is required before installation, please store the device in its original packing in a dry and clean place. The required environmental conditions can be found in the “General data” section of the “EuroProt+ Hardware description” document.

1.3.27.3. Mounting

1.3.27.3.1. Tools for mounting

The tools and screws necessary for mounting depend on the method of the mounting, see the “Mounting methods” section of the “EuroProt+ Hardware description” document.

Assuming the panel or cubicle is ready for installation of the device, screwdrivers matching the screws used, pliers, wrenches, etc. are necessary. For safety aspects, mechanical protective gloves shall be used to avoid injuries.

1.3.27.3.2. Environmental conditions

Make sure, that the mounting location fulfils environment requirements stated in the “General data” section of the “EuroProt+ Hardware description” document. The IP protection class of the device shall fit the surrounding environment at the place of installation. It is also important to have space around the device to support conventional cooling (See 3.3).

1.3.27.3.3. Mounting location

Before mounting the device make sure, that suitable space is available in the location of installation. Cutouts shall fit the device rack dimensions and it is recommended to leave 80mm free space behind the IED for the wiring.

The minimum distance between an EP+ device and its wire channel must be at least 3 cm. The minimum distance between two EP+ devices must be at least 10 cm.

1.3.27.3.4. Mounting the device

The EuroProt+ product line utilizes different rack sizes and depending on that different mounting methods. An overview of the rack sizes with dimensions and mounting methods can be found in the “Mounting methods” section of the “EuroProt+ Hardware description” document.

During the installation make sure that the shortest possible length for PE (Protective Earth) cable routing is applied.

1.3.27.3.5. Safety aspects

1.3.27.3.5.1. Earth connections

1.3.27.3.5.1.1. Protective earth

The device shall be connected to the station earth system with a minimum of 2,5 mm² cross-section solid or stranded wire. A 6,3 mm (1/4 inch) female flat connector (according to IEC 61210) shall be used crimped to the earthing wire. During the installation make sure that the shortest possible length for PE (Protective Earth) cable routing is applied.

The earth connection of the device is situated at all kinds of Power supply modules. In the case of more Power supply modules, all of them shall be earthed.

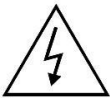

The protective earth connections should not be removed when the equipment is energized.

Picture 3-5-1-1 Earth connection point of the device at the Power supply module



1.3.27.3.5.1.2. Stranded wires

Soft soldering of stranded wires is not allowed due to the cold flow of the solder material.



Loose strands of stranded wires can cause fire risk or electric shock. Insulated crimp terminals shall be used.

1.3.27.3.5.1.3. Cable screen connection

The screen of the telecommunication cables connected directly to the device shall be terminated to the earthing connection point of the corresponding module.

Picture 3-5-1-3 An example of the cable screen connection

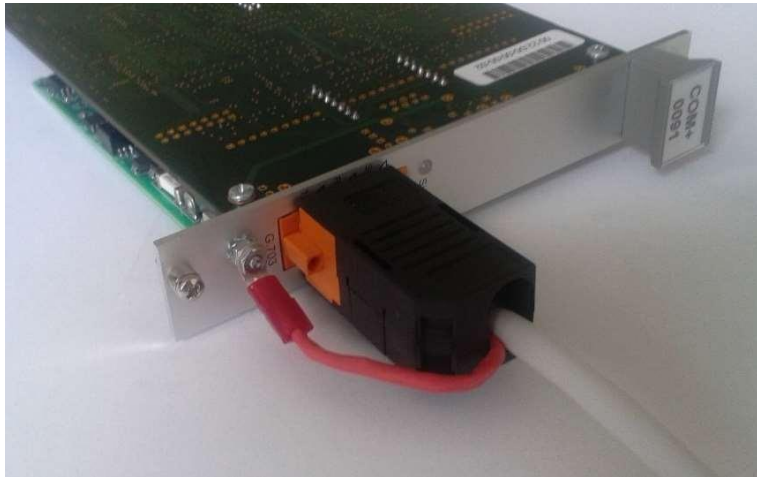

1.3.27.3.5.1.4. CT and VT circuits

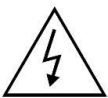

The CT and VT circuits to be connected to the device shall be connected to the station earth system.

1.3.27.3.5.2. Connections of the device

Before connecting the wires, make sure that all voltage levels correspond to the device ratings. It is particularly important by the power supply, trip and binary input, CT and VT module

Use only the connectors provided to the device or identical ones.

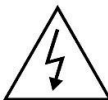

The CT connectors shall be fixed with screws provided. During the operation of the device, the CT connectors can be disconnected only after the CT circuits having short-circuited.

1.3.27.3.5.3. Optical ports



Take adequate measures to protect your eyes and do not view directly into optical ports.

The fiber optics cables are vulnerable. Sharp bending can damage them. The minimum bending radius can be between 15 cm and 25 cm approximately, depending on the type and the material of the cable. For details see the datasheets of the fiber optics cables to be installed. The fiber shall not be twisted or bent. When connecting or disconnecting the cable always hold the connector, not the cable.

1.3.27.3.5.4. Removing and changing modules

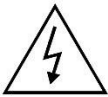

Before removing and changing modules first the power supply voltage of the device shall be disconnected. Then all the energizing quantities connected to each module of the device shall be disconnected. Before removing the connectors of the CT modules, the CT circuits shall be short-circuited and disconnected.

The protective earth connection can be disconnected last if it is necessary (e.g. when removing a Power supply module).



The devices contain components that are sensitive to electrostatic discharges. ESD wrist strap shall be worn during any operations with modules.



Some of the modules can operate at high internal temperatures. Remove these modules carefully to avoid any burn injury. Take care of the possible high temperature at each module.



The modules have got sharp edges. Remove them carefully to avoid injury.

After changing a module, it shall be fixed with the screws provided with a torque of 0,5 Nm. Use Philips 2 screwdriver.

1.3.27.4. Wiring

1.3.27.4.1. Tools for connecting

Screwdrivers for the connectors: blade 0,6/3,5 mm, 0,4/2,5 mm.

Cutter, stripper, crimper tools to prepare the connecting end of the wires.

1.3.27.4.2. Connectors

The “Connectors” section of the “EuroProt+ Hardware description” provides information about the required conductor dimensions and connecting methods. The “Connectors” table shall be used together with the other sections describing the different modules.

1.3.27.5. Deinstallation and Repair

1.3.27.5.1. Deinstallation



Before removing the device make sure, that all incoming power supply and control voltages are switched off. The earth connection of the device shall be disconnected last.

1.3.27.5.2. Repair



Thanks to its modular design, many hardware problems can be fixed by replacing single modules. By executing this procedure note, that the printed board’s surface may get hot during normal operation.



In addition, attention shall be paid to the sharp edges of the modules to avoid minor injuries on the hand.

1.3.27.5.3. Disposal



Removed IEDs shall be handed over to a local electronic waste handler for proper disposal and recycling.

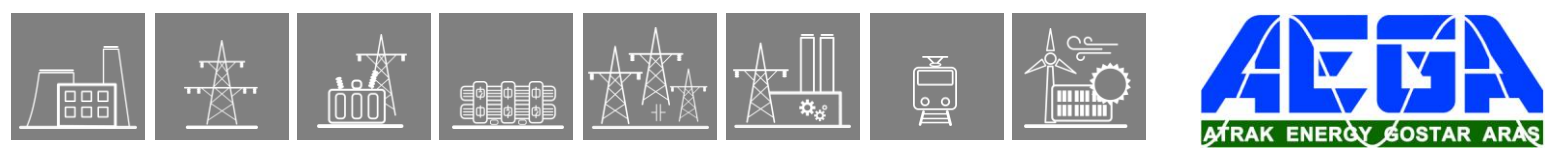

Table 5-3 Disposal of the components and parts

IED	PARTS	MATERIAL	METHOD OF DISPOSAL
Enclosure	Metal sheets, fastening elements	Aluminum, steel	Separation and recycling
Modules	Metallic parts, fastening elements	Aluminum, steel	Separation and recycling
	Mounted PC boards	Plastic, various electronic elements	Separation and recycling
	Connectors	Plastic, various metals	Separation and recycling
	Transformers, coils	Iron, copper, plastic, paper	Separation and recycling
	Relays	Iron, copper, plastic, other metals	Separation and recycling
Package	Box	Cardboard	Recycling
Attachments	Manuals, certificates	Paper	Recycling

1.3.28. transcoder unit for transformer tap changer

1.3.28.1. Introduction

The TRCS is a special device, which encodes the 28 stage-state of the transformer voltage regulator into 5-bit binary code.



Figure 1-1 Front view and rear view with fastening for mounting rail

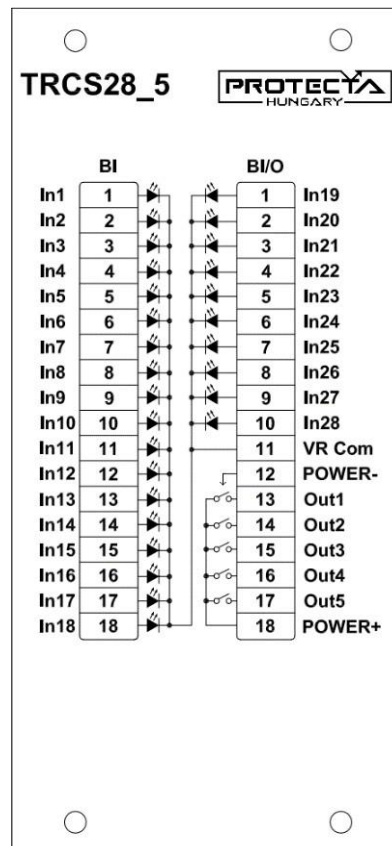

Figure 1-2 Connector arrangement

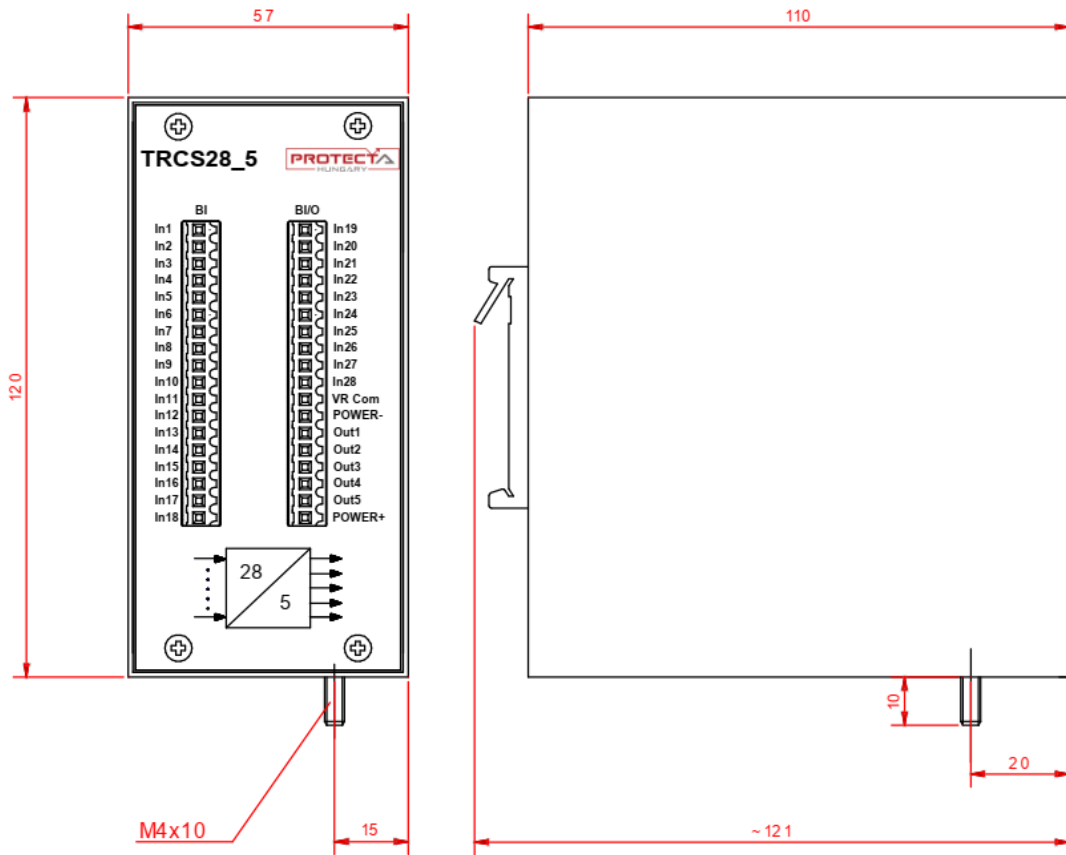

Figure 1-3 TRCS module dimensions

Table 1-1 TRCS technical information

DEVICE TYPE	TRCS
NUMBER OF INPUTS	28
NOMINAL VOLTAGE OF THE INPUTS	48V DC/110V DC/220V DC (Ordering option)
NUMBER OF OUTPUTS	5
NOMINAL VOLTAGE OF THE OUTPUTS	250V AC/DC
OUTPUT CONTINUES CARRY	6 A
CONNECTOR TYPE	Weidmüller BL 3.5/18/180

Output main features:

- Breaking capacity, (L/R = 40 ms) at 110 V DC: 0.2 A, at 220 V DC: 0.1 A

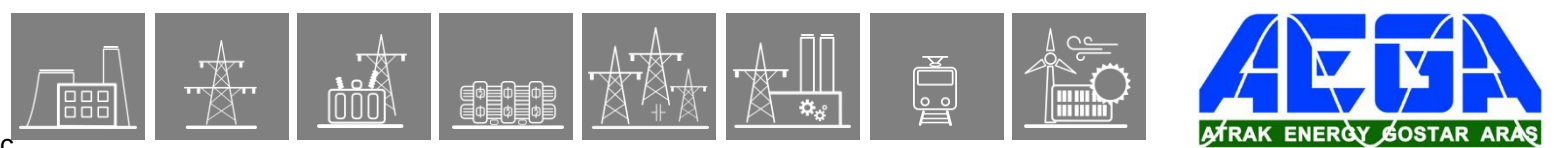

1.3.28.2. Application

1.3.28.2.1. Internal logic, operation of the outputs

According to the current state of the tap changer/voltage regulator, one of the inputs of the TRCS is energized. The outputs are controlled by a static internal logic that realizes the number of the energized input in binary form.

As an example, if the input In11 is active, then the outputs will form the number **11** in binary (with five bits it becomes **01011**), where the lowest position belongs to Out1, so the active outputs will be Out1, Out2 and Out4.

The table below shows the combinations of the outputs according to the active input.

Table 2-1 Truth table of the TRCS logic

INPUT	OUT1	OUT2	OUT3	OUT4	OUT5
1	1	0	0	0	0
2	0	1	0	0	0
3	1	1	0	0	0
4	0	0	1	0	0
5	1	0	1	0	0
6	0	1	1	0	0
7	1	1	1	0	0
8	0	0	0	1	0
9	1	0	0	1	0
10	0	1	0	1	0
11	1	1	0	1	0
12	0	0	1	1	0
13	1	0	1	1	0
14	0	1	1	1	0
15	1	1	1	1	0
16	0	0	0	0	1
17	1	0	0	0	1
18	0	1	0	0	1
19	1	1	0	0	1
20	0	0	1	0	1
21	1	0	1	0	1
22	0	1	1	0	1
23	1	1	1	0	1
24	0	0	0	1	1
25	1	0	0	1	1
26	0	1	0	1	1
27	1	1	0	1	1
28	0	0	1	1	1

1.3.28.2.2. Connection and setup

The TRCS works together with the Automatic Tap Changer Controller (ATCC – Voltage Control) function block. [Figure 2-1](#) shows the necessary connections to apply the device properly:

- The **In1..28** inputs are connected to the tap changer.
- The **VR Com** and **POWER-** inputs are connected to the common point of the tap changer's voltage. The latter is necessary for controlling the outputs.
- The **Out1..5** outputs provide the encoded state signals of the tap changer; the 5 outputs are connected to 5 binary inputs on the corresponding EuroProt+ device
- The voltage that is to be switched on the outputs is connected to the **POWER+** input. This voltage is defined by the nominal voltage of the binary input module of the EuroProt+ device which the Out1..5 outputs are wired to.
- The *logical connection* between the binary input module and the ATCC function block is made in the device software configuration, edited in Logic Editor of the EuroCAP software.
- The *parameter of the ATCC function* is set either on the local (LCD) or the remote (web interface) HMI of the device.

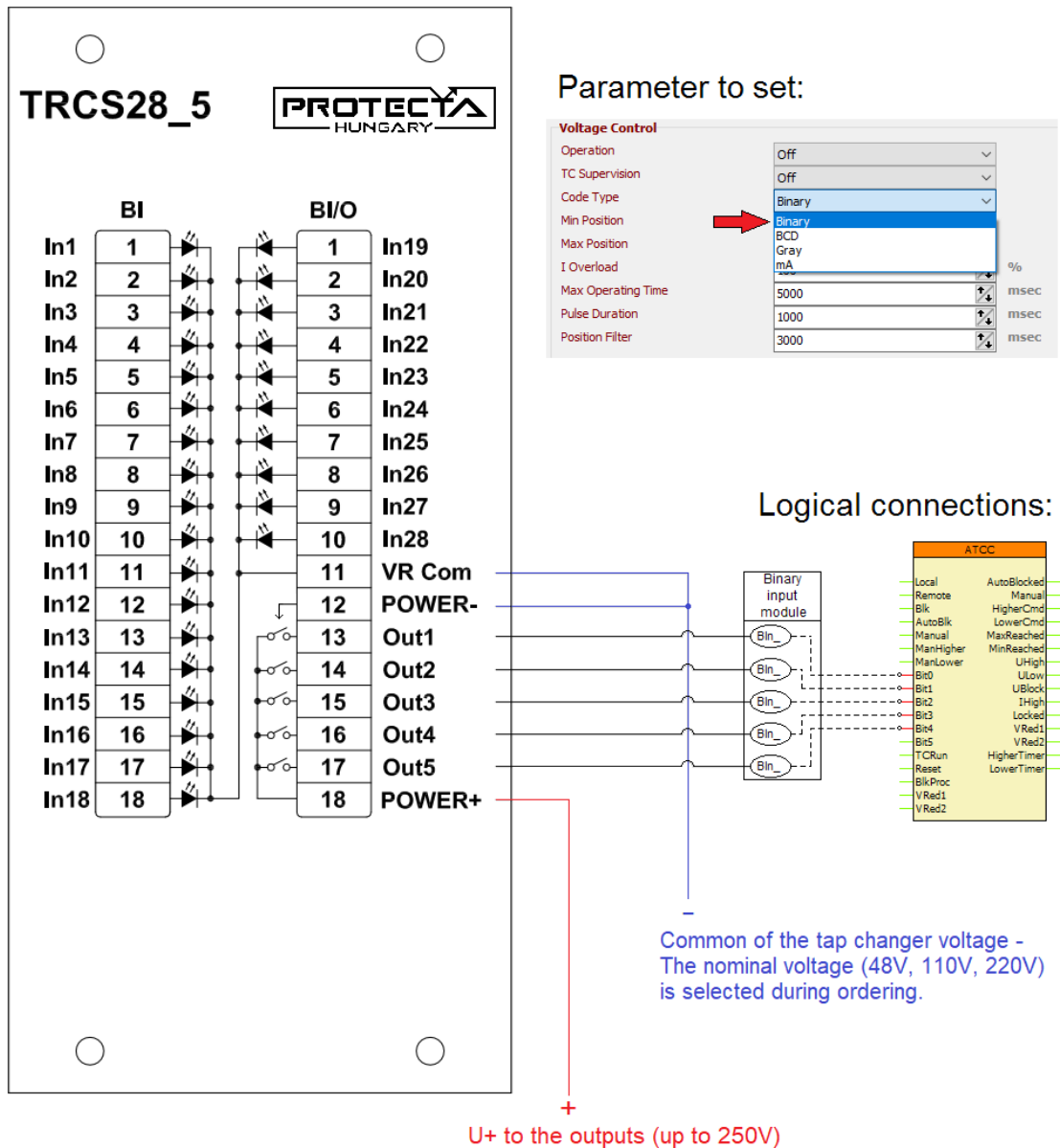
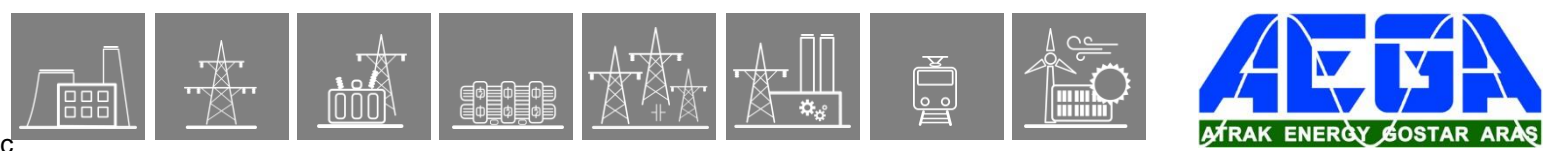
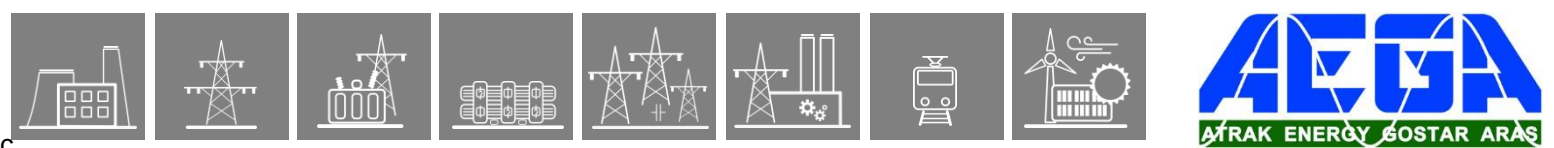

Figure 2-1 Wiring diagram and function setting



1.3.28.3. General data

- Storage temperature: - 40 °C ... + 70 °C
- Operation temperature: - 20 °C ... + 55 °C
- Humidity: 10 % ... 93 %
- Altitude: up to 2000 m
- Atmospheric pressure: 86 ... 106 kPa



1.3.28.3.1. Standard conformance

- Electrostatic discharge immunity (ESD), IEC-EN 60255-26:2013, Level 4
 - Test voltages: 15 kV air discharge, 8 kV contact discharge
- Radiated, radio-frequency, electromagnetic field immunity, IEC-EN 60255-26:2013 Level 3
 - Test field strength: 10 V/m
- Electrical fast transient/burst immunity (EFT/B), IEC-EN 60255-26:2013, Level 4
 - Test voltage: 4 kV
- Surge immunity test, IEC-EN 60255-26:2013
 - Test voltages: 2 kV line-to-earth, 1 kV line-to-line
- Immunity to conducted disturbances, induced by radio-frequency fields, IEC-EN 60255-26:2013, Level 3
 - Test voltage: 10 V
- Damped oscillatory wave immunity test, IEC-EN 60255-26:2013
 - Test frequency: 1 MHz
 - Test voltage: 2.5 kV in common mode, 1 kV in differential mode
- Voltage dips, short interruptions and voltage variations immunity, IEC-EN 60255-26:2013
 - Voltage dips: 40 % (200 ms), 70 % (500 ms), 80 % (5000 ms)
- Ripple on d.c. input power port immunity, IEC-EN 60255-26:2013
 - Level 4, 15 % of rated d.c. value
- Power frequency magnetic field immunity test, IEC-EN 60255-26:2013, Level 5
 - Test field strength: 100 A/m continuous, 1000 A/m for 3 s
- Power frequency immunity test on the binary inputs, IEC-EN 60255-26:2013, Class A
 - Test voltages: 300 V in common mode, 150 V in differential mode
- Insulation tests, IEC-EN 60255-27:2013
 - Impulse voltage test
 - Test levels: 5 kV (1 kV for transducer and temperature measuring inputs)
 - Dielectric test
 - Test levels: 2 kV AC 50 Hz (0.705 kV DC for transducer inputs)
 - Insulation resistance
 - Insulation resistance > 15 GΩ
- Radiated emission, IEC-EN 60255-26:2013
 Limits:
 - 30 MHz to 230 MHz: 50 dB(μV/m) quasi peak, 3 m
 - 230 MHz to 1 000 MHz: 57 dB(μV/m) quasi peak, 3 m
 - 1 GHz to 3 GHz: 76 dB(μV/m) peak, 3 m
 - 3 GHz to 6 GHz: 80 dB(μV/m) peak, 3 m
- Conducted emission, IEC-EN 60255-26:2013
 Limits:
 - 0,15 MHz to 0,50 MHz: 79 dB(μV) quasi peak, 66 dB(μV) average
 - 0,5 MHz - 30 MHz: 73 dB(μV) quasi peak, 60 dB(μV) average
- Vibration, shock, bump and seismic tests on measuring relays and protection equipment
 - Vibration tests (sinusoidal), Class I, IEC 60255-21-1:1988
 - Shock and bump tests, Class I, IEC 60255-21-2:1988
 - Seismic tests, Class I, IEC 60255-21-3:1993

1.3.28.4. Mechanical data

1.3.28.4.1. General mechanical data

- Construction
 - Painted steel surface
- IP protection:
 - IP2x
- Size:
 - See [Figure 1-3](#) for the device dimensions
- Weight:
 - 0.7 kg

1.3.28.4.2. Connectors

Table 4-1 Connectors on the TRCS

CONNECTOR NAME	CONNECTOR TYPE	STRIP LENGTH [MM]	CONDUCTOR AREA [MM ²]	CONDUCTOR DIAMETER [MM]	TIGHTENING TORQUE [Nm]	MINIMUM BEND RADIUS*
BL3.5 (-)	Weidmüller BL 3.5/18/180	6	0.2 – 1.5	0.5 – 1.4	0.2 – 0.25	3 × OD**
PE FASTON TERMINAL	TE Connectivity 6.3x0.8	7	min. 4	min. 2.3	-	3 × OD**

* Bend radius is measured along the inside curve of the wire or wire bundles.

** OD is the outer diameter of the wire or cable, including insulation.

The tightening torque of the screw for protective earth connection and the wall mounting must be approx. 5 Nm.

During the installation, make sure that the shortest possible length for PE (Protective Earth) cable. The minimum distance between the device and its wire channel must be at least 3 cm.

2. Function and I/O listing

The functions listed in Table 2-1 below are the ones that are present most commonly in the configurations, thus they can be considered as factory default arrangements. The hardware information corresponds to the maximum available number of digital I/O, and the default number of analog inputs.

For short descriptions for each function please refer to Chapter 3. Detailed information is available in their respective stand-alone descriptions on the Protecta website after logging in.

*The 'INST.' column contains the numbers of the pre-configured function blocks in the factory configuration. These numbers may be different in order to meet the user's requirements.

Transformer protection and control Automatic voltage regulator												
	FAMILY			EuroProt+								
	TYPE			DTRV								
	CONFIGURATION			E0	E1	E2	E3	E4	E5	E6	E7	
HARDWARE	CT inputs			4	8	8	8	12	12	12	4+4(op.)	
	VT inputs					4	4		4	8	4+4(op.)	
	Digital inputs (max)			128	112	112	112	100	100	88	128	
	Signaling relay outputs (max)			60	60	60	60	60	60	60	60	
	Fast Trip outputs (max)			12	12	12	12	12	12	12	12	
FUNCTIONALITY	Function name	IEC	ANSI	*INST.	E0	E1	E2	E3	E4	E5	E6	E7
	Overexcitation	V/Hz	24	1			✓	✓		✓	✓	
	Definite time undervoltage protection	U <, U <<	27	2	✓		✓	✓		✓	✓	✓
	Negative sequence overcurrent protection	I2 >	46	1	✓	✓	✓	✓	✓	✓	✓	
	Negative sequence overvoltage protection	U2 >	47	1	✓		✓	✓		✓	✓	
	Thermal protection line	T >	49	1	✓	✓	✓	✓	✓	✓	✓	
	Three-phase instantaneous overcurrent protection	I >>>	50	1	✓	✓	✓	✓	✓	✓	✓	
	Residual instantaneous overcurrent protection	Io >>>	50N	1	✓	✓	✓	✓	✓	✓	✓	
	Breaker failure protection	CBFP	50BF	1	✓	✓	✓	✓	✓	✓	✓	
	Three-phase time overcurrent protection	I >, I >>	51	2	✓	✓	✓	✓	✓	✓	✓	
	Residual time overcurrent protection	Io >, Io >>	51N	2	✓	✓	✓	✓	✓	✓	✓	
	Definite time overvoltage protection	U >, U >>	59	2	✓		✓	✓		✓	✓	✓
	Residual overvoltage protection	Uo >, Uo >>	59N	2	✓		✓	✓		✓	✓	
	Three-phase directional overcurrent protection	I Dir >, I Dir >>	67	2	✓							
	Switch onto fault preparation function			1	✓							
	Residual directional overcurrent protection	Io Dir >, Io Dir >>	67N	2	✓		✓	✓		✓	✓	
	Inrush detection and blocking	I2h >	68	1	✓							
	Overfrequency protection	f >, f >>	81O	2	✓		✓	✓		✓	✓	
	Underfrequency protection	f <, f <<	81U	2	✓		✓	✓		✓	✓	
	Rate of change of frequency protection	df/dt	81R	1	✓		✓	✓		✓	✓	
	Restricted earth fault	REF	87N	1	✓	✓	✓	✓	✓	✓	✓	
Transformer differential	3IdT >	87T	1		2w	2w	2w	3w	3w	3w		
Automatic voltage regulator (AVR) / tap change control		90V	1				✓			✓	✓	
Trip Logic		94		✓	✓	✓	✓	✓	✓	✓	✓	
Lockout trip logic		86			Op.	Op.	Op.	Op.	Op.	Op.	Op.	
Bay control				✓	✓	✓	✓	✓	✓	✓	✓	
Circuit breaker wear				✓	✓	✓	✓	✓	✓	✓	✓	
Circuit breaker control				✓	✓	✓	✓	✓	✓	✓	✓	
Disconnecter control				✓	✓	✓	✓	✓	✓	✓	✓	
Ethernet Links					Op.	Op.	Op.	Op.	Op.	Op.	Op.	
Trip Circuit Supervision		74TC		✓	✓	✓	✓	✓	✓	✓	✓	
Fuse failure (VTS)		60	1	✓		✓	✓	✓	✓	✓	✓	
Current unbalance protection		60	1	✓	✓	✓	✓	✓	✓	✓	✓	
Measuring	Current input			✓	✓	✓	✓	✓	✓	✓	✓	
	Voltage input			✓		✓	✓	✓	✓	✓	✓	
	Line measurement			✓	✓	✓	✓	✓	✓	✓	✓	

Table 2-1 Basic functionality and I/O

3. Software configuration

3.1. Protection functions

The E7-TR configuration is designed to perform the transformer tap-changer controller function. It measures three phase currents and the zero sequence current component and additionally three phase voltages and the zero sequence voltage component from both sides of the transformer. The tap-changer controller function considers also the voltage drop of serial network elements and the healthy state of the supplying high voltage network. Also the voltage limitation functions are included. The realized protection functions are listed in the Table below.

Protection and control functions	IEC	ANSI	E7-TR
Definite time overvoltage protection	U >, U >>	59	X
Definite time undervoltage protection	U <, U <<	27	X
Automatic voltage regulator (AVR)		60	X

Table 1 The protection and control functions of the E7-TR configuration

The configured functions are drawn symbolically in the Figure below.

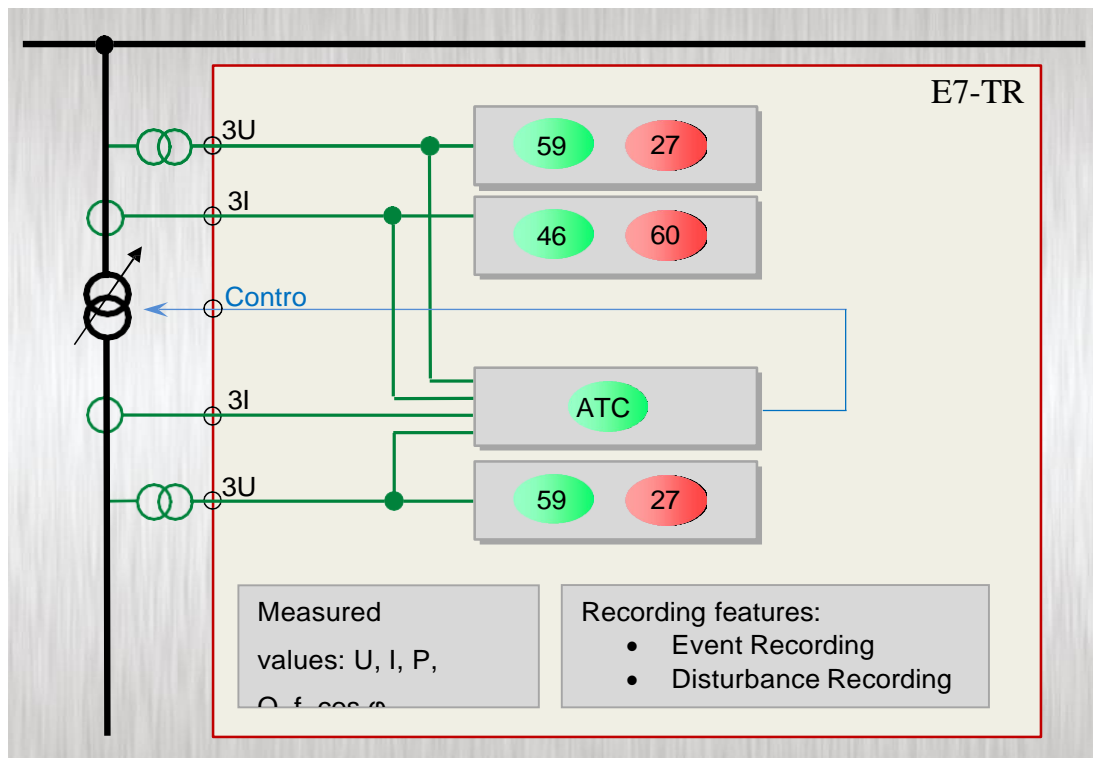
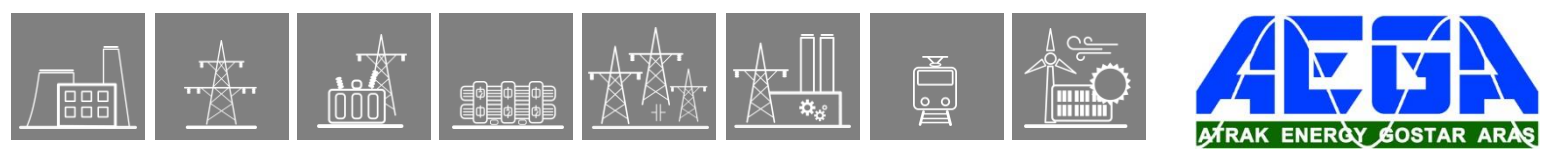

Figure 1-1 Implemented protection and control functions



3.1.1. Definite time undervoltage protection function

3.1.1.1. Application

The definite time undervoltage protection function measures three voltages. If any of them is below the level defined by parameter setting value (and above the defined minimum level), then a start signal is generated for the phases individually.

3.1.1.2. Mode of operation

The function generates start signals for the phases individually. The general start signal is set if the voltage in any of the three measured voltages is below the preset parameter setting value (and above the defined minimum level).

Note that in medium voltage applications the function uses the phase-to-phase voltages by default.

The function generates a trip command only if the time delay has expired and the parameter selection requires a trip command as well.

3.1.1.3. Operating characteristics

$$t(G) = t_{OP} \text{ when } G_{min} < G < G_s$$

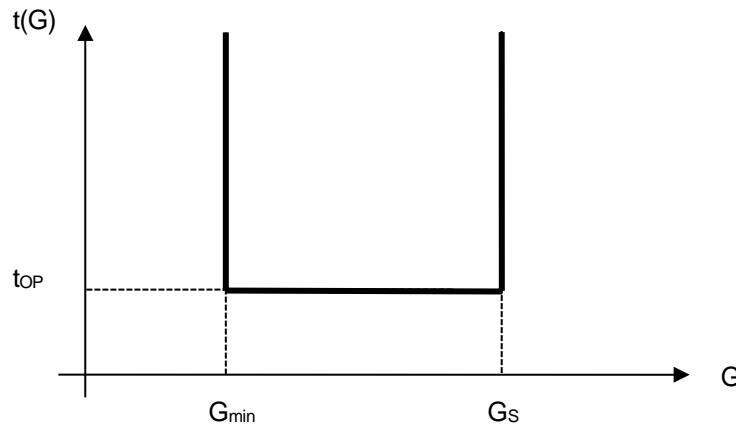

Figure 1-1 Undervoltage independent time characteristic

where
 t_{OP} (seconds)

theoretical operating time if $G_{min} < G < G_s$, fix, according to parameter setting value,

G

measured value of the characteristic quantity, Fourier base harmonic of the phase voltages (or phase-to-phase voltages),

G_s

setting value of the characteristic quantity.

3.1.1.4. Structure of the definite time undervoltage protection algorithm

Fig.1-2 shows the structure of the definite time undervoltage protection (TUV27) algorithm.

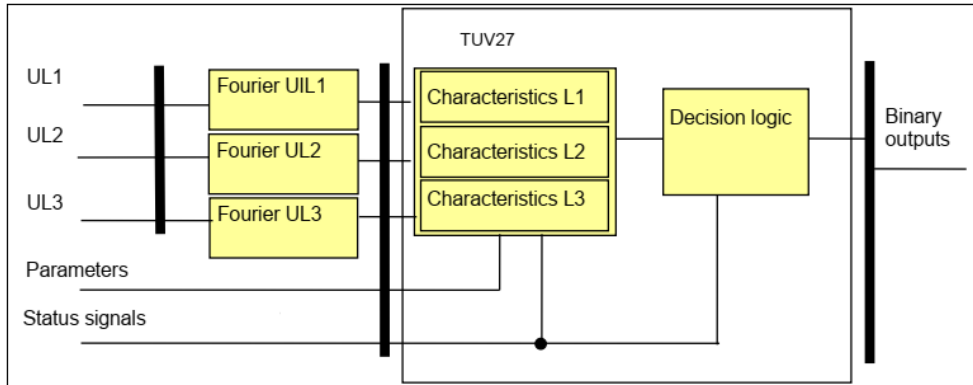

Figure 1-2 Structure of the definite time undervoltage protection algorithm

The **inputs** are

- the RMS values of the fundamental Fourier component of three phase (or phase-to-phase) voltages,
- parameters,
- status signals.

The **outputs** are

- the binary output status signals.

The **software modules** of the differential protection function:

Fourier calculations

These modules calculate the basic Fourier components of the phase voltages individually (not part of the TUV27 function). In medium voltage applications these are changed to phase-to-phase voltages.

Characteristics

This module calculates the required time delay based on the Fourier components of the phase (or phase-to-phase) voltages.

Decision logic

The decision logic module combines the status signals to generate the trip command of the function.

The following description explains the details of the individual components.

3.1.1.5. The Fourier calculation (Fourier)

These modules calculate the basic Fourier components of the phase voltages individually. They are not part of the TUV27 function; they belong to the preparatory phase.

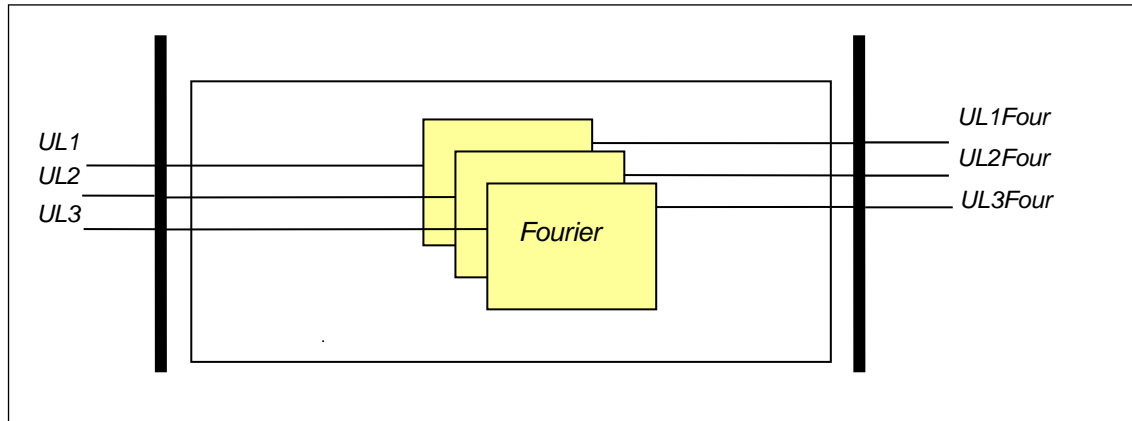

Figure 1-3 Schema of the Fourier calculation

The **inputs** are the sampled values of the three phase voltages (UL1, UL2, UL3)

The **outputs** are the basic Fourier components of the analyzed voltages (UL1Four, UL2Four, UL3Four).

The phase-to-phase voltages (if used) are also calculated here.

3.1.1.6. The definite time characteristics (Characteristics)

This module decides the stating of the function based on the Fourier components of the phase voltages and it counts the time delay. The time delay is defined by the parameter setting, if the voltages are below the setting value.

The **inputs** are the basic Fourier components of the phase (or the calculated phase-to-phase) voltages (UL1Four, UL2Four, UL3Four) and parameters.

The **outputs** are the status signals of the three phases individually. These indicate the started state and the generated trip command if the time delay determined by the setting is expired.

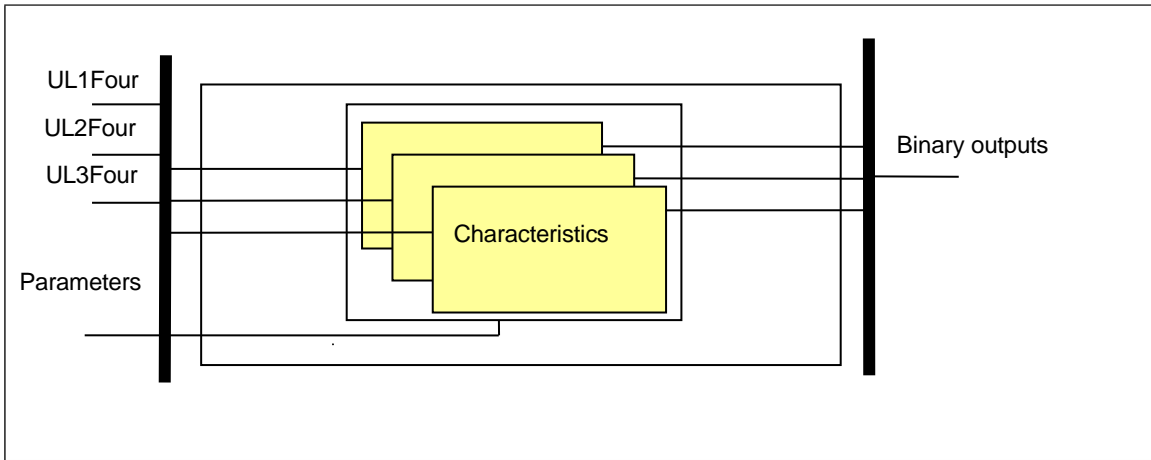

Figure 1-4 Schema of the definite time characteristic calculation

Enumerated parameter

Parameter name	Title	Selection range	Default
Enabling or disabling the undervoltage protection function			
TUV27_Oper_EPar_	Operation	Off, 1 out of 3, 2 out of 3, All	Off

Table 1-1 The enumerated parameter of the undervoltage protection function

Integer parameters

Parameter name	Title	Unit	Min	Max	Step	Default
Starting voltage level setting. If the measured voltage is below the setting value, the function generates a start signal.						
TUV27_StVol_IPar_	Start Voltage	%	30	130	1	90
Blocking voltage level setting. If the measured voltage is below the setting value, the function blocks the start signal.						
TUV27_BlkVol_IPar_	Block Voltage	%	0	20	1	10

Table 1-2 Integer parameters of the undervoltage protection function

Floating point parameter

Parameter name	Title	Unit	Min	Max	Step	Default
Starting voltage level setting. If the measured voltage is below the setting value, the function generates a start signal.						
TUV27_ResetRatio_FPar_	Reset Ratio	%	1	10	1	5

Table 1-3 Floating point parameter of the undervoltage protection function

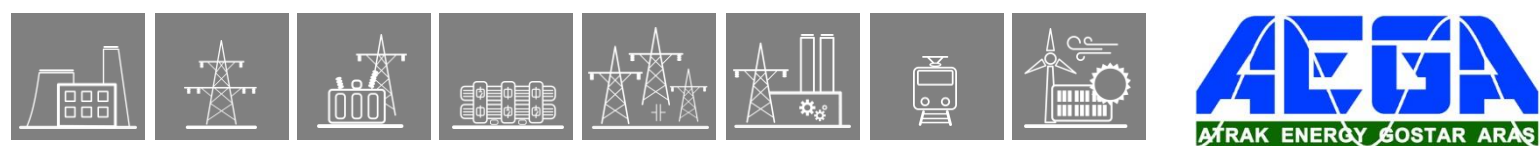

Boolean parameter

Parameter name	Title	Default	Explanation
TUV27_StOnly_BPar_	Start Signal Only	0	Selection if starting and trip signal or starting signal only is to be generated. Set 0 for trip command generation.

Table 1-4 The Boolean parameter of the undervoltage protection function

Timer parameter

Parameter name	Title	Unit	Min	Max	Step	Default
Time delay of the undervoltage protection function.						
TUV27_Delay_TPar_	Time Delay	ms	50	60000	1	100

Table 1-5 Timer parameter of the undervoltage protection function

The **binary output status signals** of the three-phase definite time undervoltage protection function are listed in *Table 1-6*.

Binary output signals	Signal title	Explanation
TUV27_StL1_Grl_	StL1	Starting of the function in phase L1*
TUV27_TrL1_Grl_	TrL1**	Trip command of the function in phase L1*
TUV27_StL2_Grl_	StL2	Starting of the function in phase L2*
TUV27_TrL2_Grl_	TrL2**	Trip command of the function in phase L2*
TUV27_StL3_Grl_	StL3	Starting of the function in phase L3*
TUV27_TrL3_Grl_	TrL3**	Trip command of the function in phase L3*

*In case of phase-to-phase voltages, these are changed to L12, L23, L31 respectively.

**The trip signals are not published for the phases individually

Table 1-6 The binary output status signals of the definite time undervoltage protection function

3.1.1.7. The decision logic (Decision logic)

The decision logic module combines the status signals, binary and enumerated parameters to generate the trip command of the function.

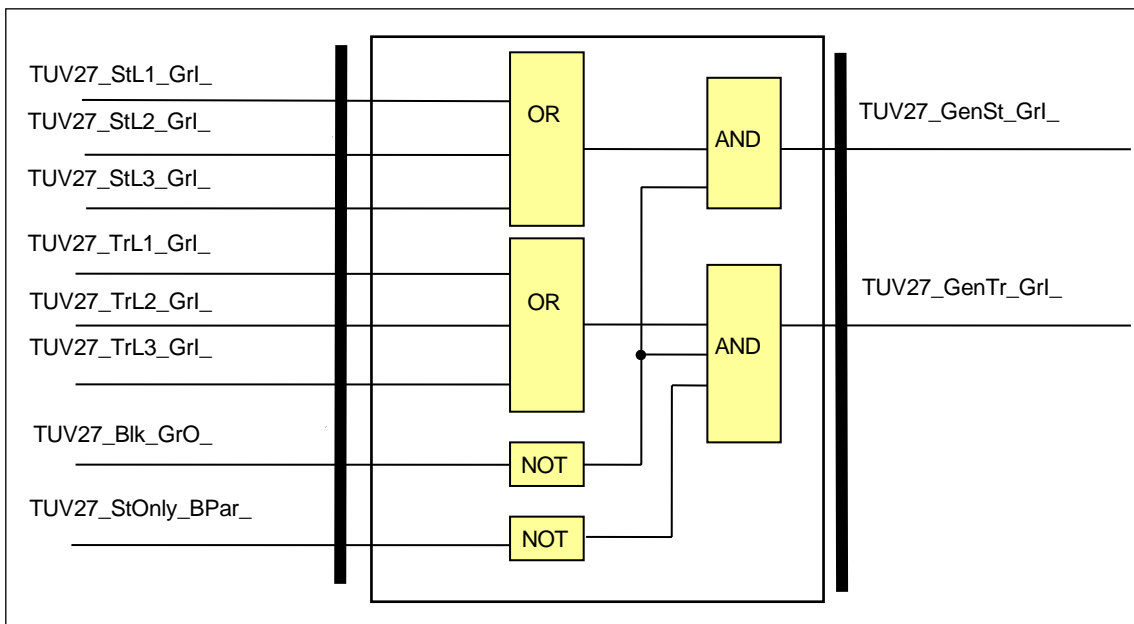

Figure 1-5 The logic scheme of the definite time undervoltage protection function

Binary input signals	Signal title	Explanation
TUV27_StL1_Grl_	StL1	Starting of the function in phase L1*
TUV27_TrL1_Grl_	TrL1**	Trip command of the function in phase L1*
TUV27_StL2_Grl_	StL2	Starting of the function in phase L2*
TUV27_TrL2_Grl_	TrL2**	Trip command of the function in phase L2*
TUV27_StL3_Grl_	StL3	Starting of the function in phase L3*
TUV27_TrL3_Grl_	TrL3**	Trip command of the function in phase L3*

*In case of phase-to-phase voltages, these are changed to L12, L23, L31 respectively.

**The trip signals are not published for the phases individually

Table 1-7 The binary input signals of the definite time undervoltage protection function

Boolean parameter

Parameter name	Title	Default
Enabling start signal only:		
TUV27_StOnly_BPar_	Start Signal Only	FALSE

Table 1-8 The Boolean parameter of the definite time undervoltage protection function

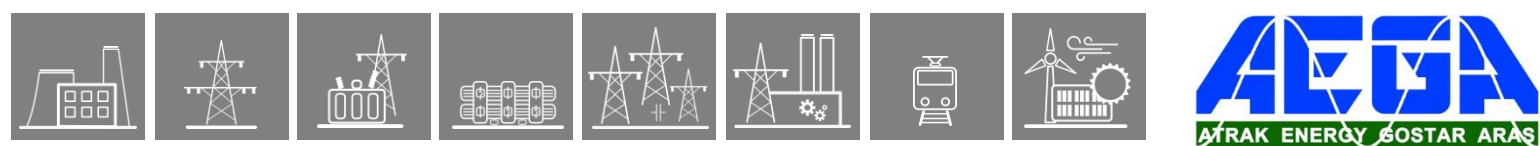

Binary status signals

The undervoltage protection function has a binary input signal, which serves the purpose of disabling the function. The conditions of disabling are defined by the user, applying the graphic equation editor.

Binary input status signal	Signal title	Explanation
TUV27_BlK_GrO_	Blk	Output status of a graphic equation defined by the user to disable the definite time undervoltage protection function.

Table 1-9 The binary input status signal of the definite time undervoltage protection function

Binary output status signal	Signal title	Explanation
TUV27_GenSt_Grl_	GenSt	General starting of the function
TUV27_GenTr_Grl_	GenTr	General trip command of the function

Table 1-10 The binary output status signals of the definite time undervoltage protection function

3.1.1.8. Technical summary

3.1.1.8.1. Technical data

Function	Value	Accuracy
Pick-up starting accuracy		$< \pm 0,5 \%$
Blocking voltage		$< \pm 1,5 \%$
Reset time		
$U > \rightarrow U_n$	50 ms	
$U > \rightarrow 0$	40 ms	
Operate time accuracy		$< \pm 20 \text{ ms}$
Minimum operate time	50 ms	

Table 1-11 Technical data of the undervoltage protection function

3.1.1.8.1.1. The parameters

The parameters are summarized in Chapters 3.1.2.5 and 3.1.2.6

3.1.1.8.2. Binary output status signals

The **binary output status signals** of undervoltage protection function are listed in Table 1-12

Binary output status signal	Title	Explanation
TUV27_StL1_Grl_	StL1	Start in phase L1*
TUV27_StL2_Grl_	StL2	Start in phase L2*
TUV27_StL3_Grl_	StL3	Start in phase L3*
TUV27_GenSt_Grl_	GenSt	General start signal
TUV27_GenTr_Grl_	GenTr	General trip command

*In case of phase-to-phase voltages, these are changed to L12, L23, L31 respectively.

Table 1-12 The binary output status signals of the undervoltage protection function

3.1.1.8.3. Binary input status signals

Binary input signals

The undervoltage protection function has a binary input signal, which serves the purpose of disabling the function. **The conditions of disabling are defined by the user, applying the graphic equation editor.**

Binary status signal	Title	Explanation
TUV27_BlK_GrO_	Blk	Blocking of the undervoltage protection function

Table 1-13 The binary input signal of undervoltage protection function

3.1.1.8.4. The function block

The function block of undervoltage protection function is shown in Figure 1-6. This block shows all binary input and output status signals that are applicable in the graphic equation editor.

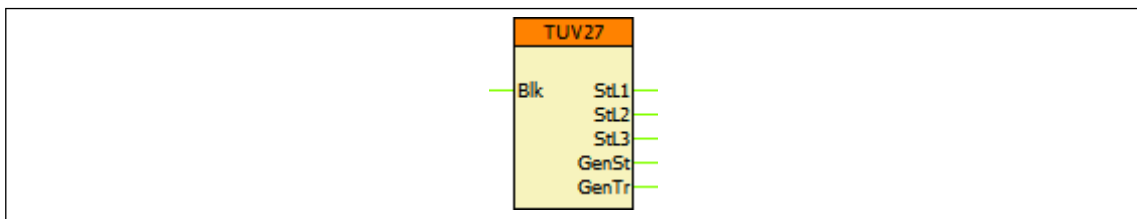

Figure 1-6 The function block of undervoltage protection function

3.1.2. Definite time overvoltage protection function

3.1.2.1. Application

The definite time overvoltage protection function measures three voltages. If any of them is above the level defined by parameter setting, then a start signal is generated for the phases individually.

3.1.2.2. Mode of operation

The function generates start signals for the phases individually. The general start signal is generated if the voltage in any of the three measured voltages is above the level defined by parameter setting value.

Note that in medium voltage applications the function uses the phase-to-phase voltages by default.

The function generates a trip command only if the time delay has expired and the parameter selection requires a trip command as well.

3.1.2.3. Operating characteristics

$$t(G) = t_{OP} \text{ when } G > G_s$$

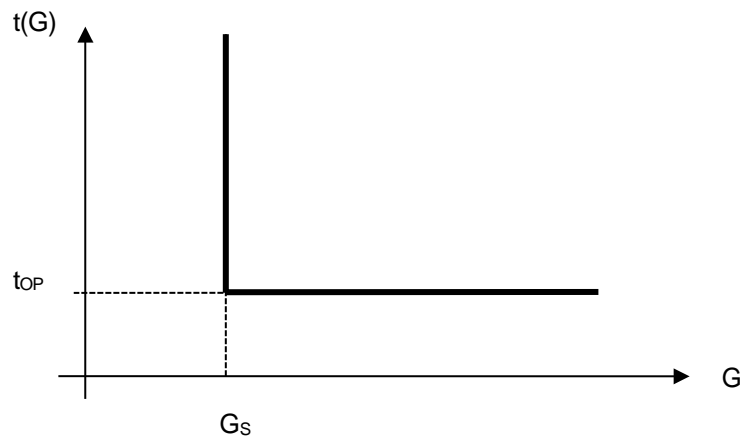

Figure 1-1 Overvoltage definite time characteristic

where	
t_{OP} (seconds)	theoretical operating time if $G > G_s$, fix, according to the parameter setting,
G	measured value of the characteristic quantity, Fourier base harmonic of the phase voltages (or phase-to-phase voltages),
G_s	setting value of the characteristic quantity.

3.1.2.4. Structure of the definite time overvoltage protection algorithm

Fig.1-2 shows the structure of the definite time overvoltage protection (TOV59) algorithm.

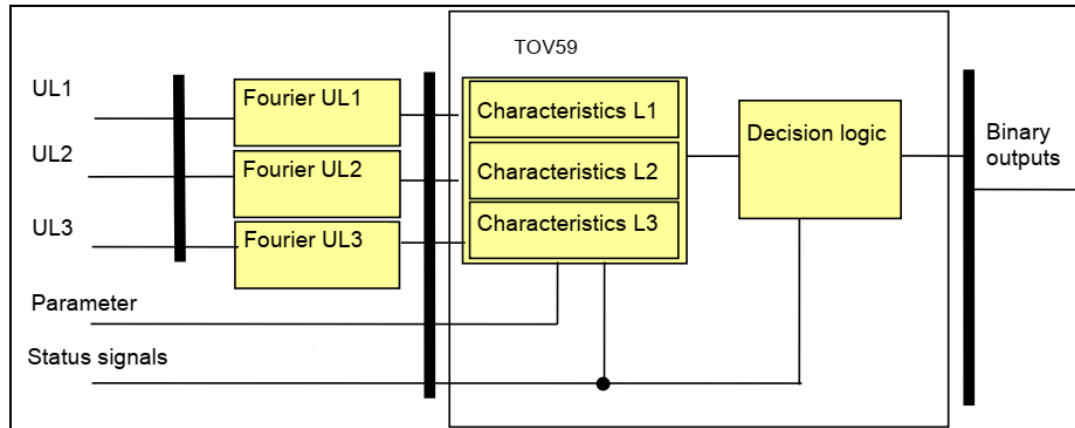

Figure 1-2 Structure of the definite time overvoltage protection algorithm

The **inputs** are

- the RMS values of the fundamental Fourier component of three phase voltages,
- parameters,
- status signals.

The **outputs** are

- the binary output status signals.

The **software modules** of the definite time overvoltage protection function:

Fourier calculations

These modules calculate the basic Fourier components of the phase voltages individually (not part of the TOV59 function). In medium voltage applications these are changed to phase-to-phase voltages.

Characteristics

This module calculates the required time delay based on the Fourier components of the phase (or phase-to-phase) voltages.

Decision logic

The decision logic module combines the status signals to generate the trip command of the function.

The following description explains the details of the individual components.

3.1.2.5. The Fourier calculation (Fourier)

These modules calculate the basic Fourier components of the phase voltages individually. They are not part of the TOV59 function; they belong to the preparatory phase.

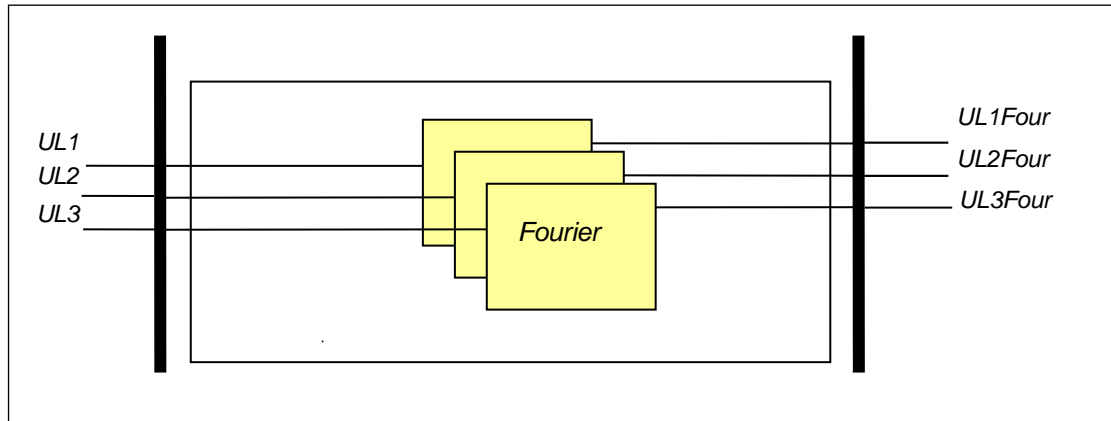

Figure 1-3 Schema of the Fourier calculation

The **inputs** are the sampled values of the three phase voltages (UL1, UL2, UL3)

The **outputs** are the RMS values of the basic Fourier components of the analyzed voltages (UL1Four, UL2Four, UL3Four).

The phase-to-phase voltages (if used) are also calculated here.

3.1.2.6. The definite time characteristics (Characteristics)

This module decides the stating of the function based on the Fourier components of the phase voltages and it counts the time delay. The time delay is defined by the parameter setting, if the voltages are above the setting value.

The **inputs** are the RMS values of the basic Fourier components of the phase (or the calculated phase-to-phase) voltages (UL1Four, UL2Four, UL3Four) and parameters.

The **outputs** are the status signals of the three phases individually. These indicate the started state and the generated trip command if the time delay determined by the setting is expired.

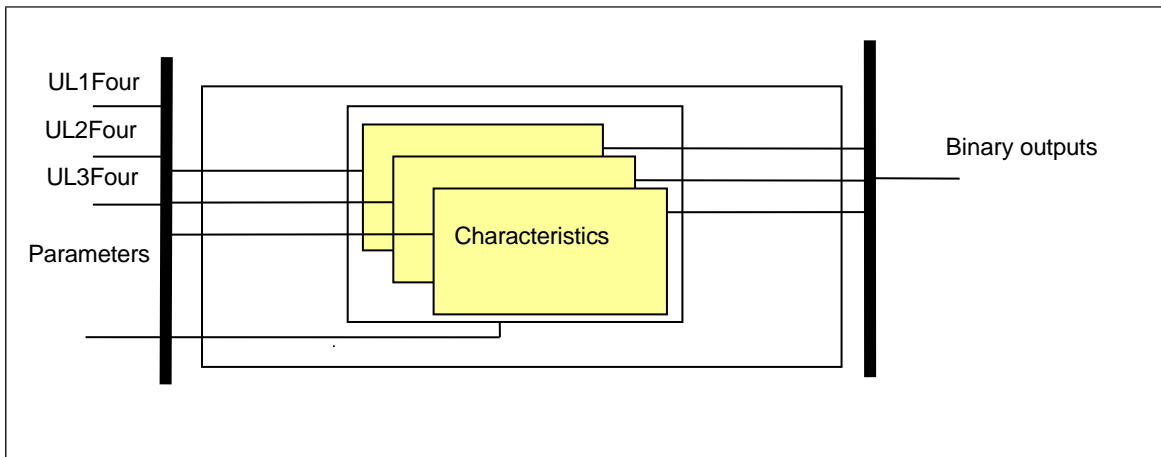

Figure 1-4 Schema of the definite time characteristic calculation

Enumerated parameter

Parameter name	Title	Selection range	Default
Enabling or disabling the overvoltage protection function			
TOV59_Oper_EPar_	Operation	Off, On	Off

Table 1-1 The enumerated parameter of the overvoltage protection function

Integer parameter

Parameter name	Title	Unit	Min	Max	Step	Default
Voltage level setting. If the measured voltage is above the setting value, the function generates a start signal.						
TOV59_StVol_IPar_	Start Voltage	%	30	130	1	110

Table 1-2 Integer parameter of the overvoltage protection function

Floating point parameter

Parameter name	Title	Unit	Min	Max	Step	Default
After starting the function drops off if the measured voltage is below the start voltage with at least this percentage.						
TOV59_ResetRatio_FPar_	Reset Ratio	%	1	10	1	5

Table 1-3 Floating point parameter of the overvoltage protection function

Boolean parameter

Parameter name	Title	Default	Explanation
TOV59_StOnly_BPar_	Start Signal Only	0	Selection if starting and trip signal or starting signal only is to be generated. Set 0 for trip command generation.

Table 1-4 The Boolean parameters of the overvoltage protection function

Timer parameter

Parameter name	Title	Unit	Min	Max	Step	Default
Time delay of the overvoltage protection function.						
TOV59_Delay_TPar_	Time Delay	ms	0	60000	1	100

Table 1-5 The timer parameter of the overvoltage protection function

The **binary output status signals** of the three-phase definite time overvoltage protection function are listed in . *In case of phase-to-phase voltages, these are changed to L12, L23, L31 respectively.

**The trip signals are not published for the phases individually

Table 1-6 below.

Binary output status signal	Signal title	Explanation
TOV59_StL1_Grl_	StL1	Starting of the function in phase L1*
TOV59_TrL1_Grl_	TrL1**	Trip command of the function in phase L1*
TOV59_StL2_Grl_	StL2	Starting of the function in phase L2*
TOV59_TrL2_Grl_	TrL2**	Trip command of the function in phase L2*
TOV59_StL3_Grl_	StL3	Starting of the function in phase L3*
TOV59_TrL3_Grl_	TrL3**	Trip command of the function in phase L3*

*In case of phase-to-phase voltages, these are changed to L12, L23, L31 respectively.

**The trip signals are not published for the phases individually

Table 1-6 The binary output status signals of the definite time overvoltage protection function

3.1.2.7. The decision logic (Decision logic)

The decision logic module combines binary signals and Boolean parameters to generate the trip command of the function.

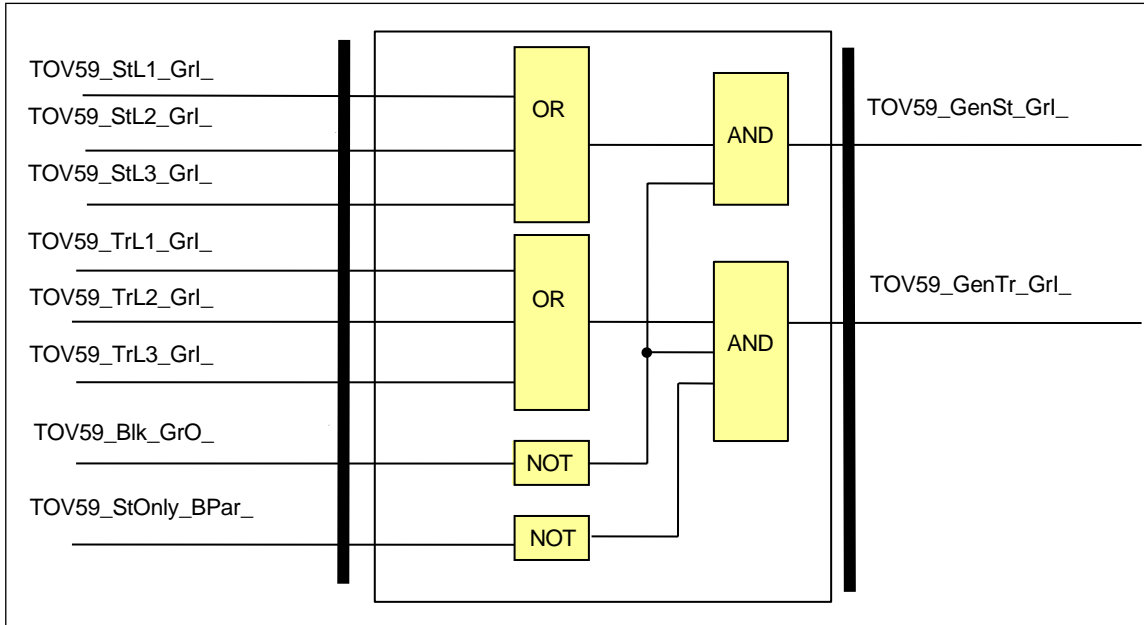

Figure 1-5 The decision logic scheme of the definite time overvoltage protection function

Binary input signal	Signal title	Explanation
TOV59_StL1_Grl_	StL1	Starting of the function in phase L1*
TOV59_TrL1_Grl_	TrL1**	Trip command of the function in phase L1*
TOV59_StL2_Grl_	StL2	Starting of the function in phase L2*
TOV59_TrL2_Grl_	TrL2**	Trip command of the function in phase L2*
TOV59_StL3_Grl_	StL3	Starting of the function in phase L3*
TOV59_TrL3_Grl_	TrL3**	Trip command of the function in phase L3*

*In case of phase-to-phase voltages, these are changed to L12, L23, L31 respectively.

**The trip signals are not published for the phases individually

Table 1-7 The binary input signals of the definite time overvoltage protection function

Boolean parameter

Parameter name	Title	Default
Enabling start signal only:		
TOV59_StOnly_BPar_	Start Signal Only	FALSE

Table 1-8 The Boolean parameter of the definite time overvoltage protection function

Binary status signals

The overvoltage protection function has a binary input signal, which serves the purpose of disabling the function. The conditions of disabling are defined by the user, applying the graphic equation editor.

Binary input status signal	Explanation
TOV59_BlK_GrO_	Output status of a graphic equation defined by the user to disable the definite time overvoltage protection function.

Table 1-9 The binary input signal of the definite time overvoltage protection function

Binary output status signal	Title	Explanation
TOV59_StL1_Grl_	StL1	Start in phase L1*
TOV59_StL2_Grl_	StL2	Start in phase L2*
TOV59_StL3_Grl_	StL3	Start in phase L3*
TOV59_GenSt_Grl_	GenSt	General start signal
TOV59_GenTr_Grl_	GenTr	General trip command

*In case of phase-to-phase voltages, these are changed to L12, L23, L31 respectively.

Table 1-10 The binary output status signals of the definite time overvoltage protection function

3.1.2.8. Technical summary

3.1.2.8.1. Technical data

Function	Value	Accuracy
Pick-up starting accuracy		$< \pm 0,5 \%$
Reset time U> \rightarrow Un U> \rightarrow 0	60 ms 50 ms	
Operate time accuracy		$< \pm 20 \text{ ms}$
Minimum operate time	50 ms	

Table 1-11 Technical data of the overvoltage protection function

3.1.2.8.2. Parameters

The parameters are summarized in Chapter 1.6 Table 1-1, Table 1-2, Table 1-3, Table 1-4, Table 1-5.

3.1.2.8.3. Binary output status signals

The **binary output status signals** of overvoltage protection function are listed in Table 1-12
The binary output status signals of the overvoltage protection function

Binary status signal	Title	Explanation
TOV59_StL1_Grl_	StL1	Start in phase L1
TOV59_StL2_Grl_	StL2	Start in phase L2
TOV59_StL3_Grl_	StL3	Start in phase L3
TOV59_GenSt_Grl_	GenSt	General start signal
TOV59_GenTr_Grl_	GenTr	General trip command

Table 1-12 The binary output status signals of the overvoltage protection function

3.1.2.8.4. Binary input status signals

Binary input signals

The overvoltage protection function has a binary input signal, which serves the purpose of disabling the function. **The conditions of disabling are defined by the user, applying the graphic equation editor.**

Binary status signal	Title	Explanation
TOV59_BlK_GrO_	Blk	Blocking of the overvoltage protection function

Table 1-13 The binary input signal of the overvoltage protection function

3.1.2.8.5. The function block

The function block of the overvoltage protection function is shown in Figure 1-6. This block shows all binary input and output status signals that are applicable in the graphic equation editor.

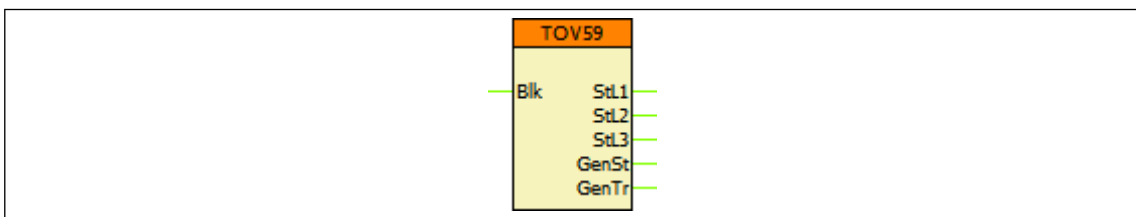

Figure 1-6 The function block of the overvoltage protection function



3.1.3. Automatic tap changer controller function (parallel transformers included)

3.1.3.1. Application

One criterion for power quality is to keep the voltage of selected points of the networks within the prescribed limits. The most common mode of voltage regulation is the application of transformers with on-load tap changers. When the transformer is connected to different taps, its turns ratio changes and supposing constant primary voltage, the secondary voltage can be increased or decreased as required.

Voltage control can take the actual load state of the transformer and the network into consideration. As a result, the voltage of a defined remote point of the network is controlled assuring that neither consumers near the busbar nor consumers at the far ends of the network get voltages out of the required range.

The voltage control function can be performed automatically, or, in manual mode of operation, the personnel of the substation can set the network voltage according to special requirements.

With the growing customer demand for the higher security and reliability of supply, it is common practice two or more transformers are operating in parallel on one site or across the network. In this situation, the main goal of the tap changer controllers is to maintain the voltage within the prescribed limits, at the same time, to minimize circulating current between parallel transformers.

The automatic tap changer controller function can be applied to perform this task.

3.1.3.1.1. Operation principles

Figure 1-1 shows the structure of the automatic tap changer controller function block.

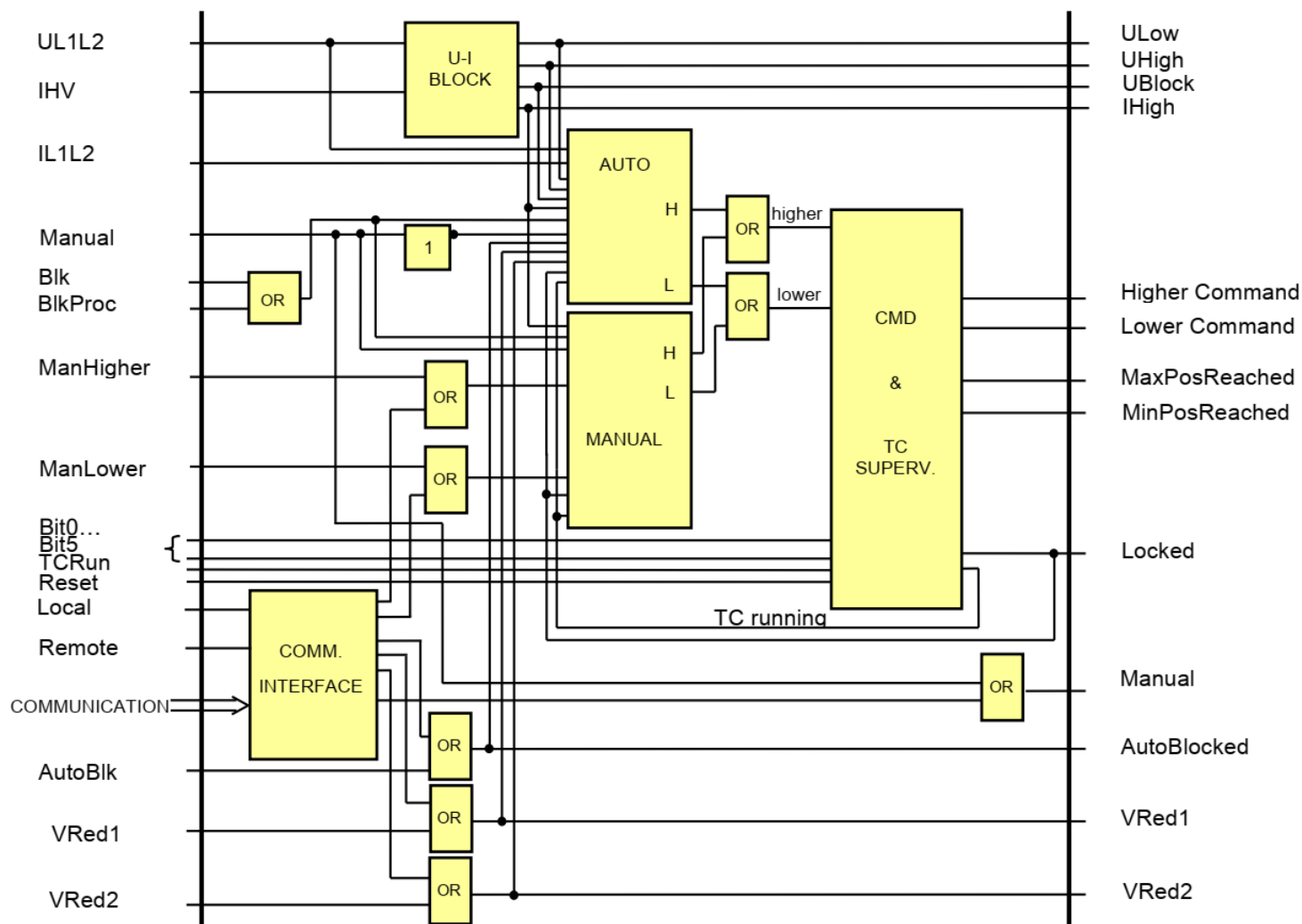

Figure 1-1 The logic schema of the automatic tap changer controller

The automatic tap changer controller function receives the following **analog inputs**:

- **UL1L2**: Line-to-line voltage of the controlled secondary side of the transformer
- **IL1L2**: Difference of the selected line currents of the secondary side of the transformer for voltage drop compensation
- **IHV** (optional): Maximum of the phase currents of the primary side of the transformer for limitation purposes

The parameter “U Correction” permits fine tuning of the measured voltage.

The **software modules** of the automatic tap changer controller function:

U-I BLOCK

This module performs an internal check before control operation. If the

AUTO

This module provides the automatic control mode of the function.

MANUAL

This module provides the manual control mode of the function.

CMD & TC SUPERV.

The software module “CMD&TC SUPERV.” is responsible for the generation of the tap changer commands. This module also supervises the operation of the tap changer.

COMM. INTERFACE

This module receives all control commands from remote control. Additionally, in case of parallel mode it is responsible for the inter-communication among the co-operating automatic tap changer controller devices.

3.1.3.2. Operation of the automatic tap changer control

The automatic tap changer control function has the “Operation” parameter which can be set to one of the following:

- *Off*, tap changer control function is switched off;
- *Single/On*, for selecting the controller in single mode or in negative reactance circulating current mode with special setting. (See Paragraph 3.1.2 for more details about negative reactance circulating current mode.);
- *Min Circulating Current*, for operating the controllers of the parallel connected transformers to minimize the circulating current. (See Paragraph 3.1.1.);
- *Master*, for selecting one of the controllers of the parallel connected transformers to be the master, to transmit commands to the slave controllers. (See Paragraph 3.1.3);
- *Slave-Cmd*, for selecting the controller to operate in slave mode, and follow the UP and DOWN commands (See Paragraph 3.1.3);
- *Slave-Tap* for selecting the controller to operate in slave mode, and drive the tap changer to the same position as the transformer assigned to the master controller. (See Paragraph 3.1.3)



3.1.3.3. Internal checks before control operation - “U-I BLOCK”

In Figure 1-1 the block “U-I BLOCK” performs the following checks before control operation:

- If the voltage of the controlled side UL1L2 is above the value set by the parameter “U High Limit”, then automatic control to increase the voltage is disabled.
- If the voltage of the controlled side UL1L2 is below the value set by the parameter “U Low Limit”, then automatic control to decrease the voltage is disabled.
- If the voltage of the controlled side UL1L2 is below the value set by the parameter “U Low Block”, then the transformer is considered to be de-energized and automatic control is completely disabled.
- If the current of the supply side IHV is above the limit set by the parameter “I Overload”, then both automatic and manual controls are completely disabled. This is to protect the switches inside the tap changer.
 - Current overload limitation on primary side IHV is not default limitation parameter. It is an ordering option. (Additional CT module has to be integrated into the tap changer controller device so that the current of the primary side can be measured.)
- If the voltage of the controlled side UL1L2 is below the value set by the parameter “U Low Block”, then parallel cooperation is disabled in Auto mode. Nevertheless, the parallel cooperation is still enabled in Manual mode.



3.1.3.4. Control mode of tap changer controller

3.1.3.4.1. Automatic control mode – “AUTO” module

The automatic control mode can be selected with the “Auto/Man” control channel (ATCC_**Man**_Con_) if the “Manual” binary input (ATCC_**Manual**_GrO_) of the function block is FALSE.

The automatic control mode can be blocked by a binary signal received via binary input “AutoBlk” and generates a binary output signal “AutoBlocked (ext)”



Follower mode

Follower mode is submode of the auto mode. It is only relevant in the parallel automatic tap changer controller function. The actual mode of the device is changed to “Follower” if the auto mode is selected and the “Operation” parameter is set to either SlaveCmd or SlaveTap.”

Voltage compensation in automatic control mode

The module “AUTO” in Figure 1-1 gets the Fourier components of the busbar voltage and those of the current:

- $UL1L2_{Re}$ and $UL1L2_{Im}$
- $IL1L2_{Re}$ and $IL1L2_{Im}$

In automatic control mode the voltage of the controlled side $UL1L2$ is compensated by the current of the controlled side $IL1L2$. This means that the voltage of the “load center” of the network is controlled to be constant, in fact within a narrow range. This assures that neither the voltage near to the busbar is too high, nor the voltage at far-away points of the network is too low. The voltage of the “load center”, i.e. the controlled voltage is calculated as:

$$|U_{control}| = |U_{bus} - U_{drop}|$$

There are two compensation modes to be selected: “Absolute” and “Complex”.

- If the parameter “Compensation” is set to “**Absolute**”, the calculation method is as follows:

In this simplified method the vector positions are not considered correctly, the formula above is approximated with the magnitudes only:

$$|U_{control}| = |U_{bus} - U_{drop}| \approx |U_{bus}| - |U_{drop}| \approx |U_{bus}| - |I| * (R)_{CompoundFactor}$$

where

- Compound Factor is a parameter value.

If the current is above the value defined by the parameter “I Comp Limit”, then in the formulas above this preset value is considered instead of the higher values measured.

The method is based on the experiences of the network operator. Information is needed: how much is the voltage drop between the busbar and the “load center” if the load of the network is the rated load. The parameter “(R) Compound Factor” means in this case the voltage drop in percent.

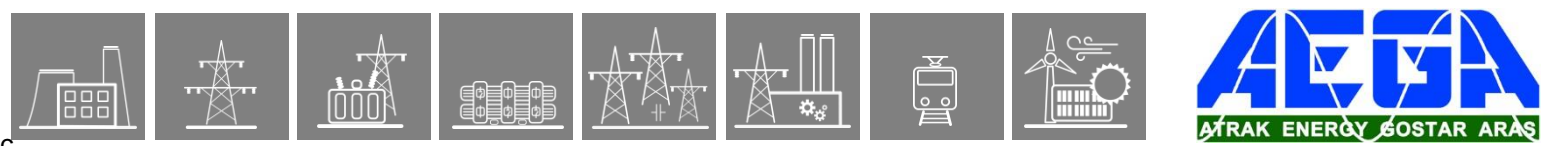

- If the parameter “Compensation” is set to “**Complex**”, the calculation method is as follows:

In this simplified method the vector positions are partly considered. In the formula above the voltage drop is approximated with the component of the voltage drop, the direction of which is the same as the direction of the bus voltage vector. (This is “length component” of the voltage drop; the “perpendicular component” of the voltage drop is neglected.)

$$|U_{control}| = |U_{bus} - [(IL1L2_{Re} + jIL1L2_{Im}) * ((R)CompoundFactor + jXCompoundFactor)]|$$

where

(R) Compound Factor is a parameter value,
 X Compound Factor is a parameter value.

The voltage of the “load center” of the network is controlled to be within a narrow range. This assures that neither the voltage near to the busbar is too high, nor the voltage at far-away points of the network is too low.

The method is based on the estimated complex impedance between the busbar and the “load center”. The parameter “(R) Compound Factor” means in this case the voltage drop in percent, caused by the real component of the rated current.

The parameter “X Compound Factor” means in this case the voltage drop in percent, caused by the imaginary component of the rated current.

NOTE: if the active power flows from the network to be controlled to the busbar then in “Absolute” mode no compounding is performed.

3.1.3.4.1.1. Voltage checking in automatic control mode

In automatic control mode the calculated $|U_{control}|$ voltage is checked to see if it is outside the limits. If so, is outside the limits, then timers are started.

The limits are defined by parameter values:

U Set* is the setting value defining the center of the permitted range

* “U Set” value can be updated during the calendar day when “Time scheduler (for ATCC)” function is set to enabled. More details can be found in Chapter 1.4.1.3.

U Deadband is the width of the permitted range in both + and – directions

Deadband Hysteresis is the hysteresis decreasing the permitted range of the “U Deadband” during the running of the timer (see Chapter 1.4.1.2) before the generation of the control command. Also see Figure 1-3.

In an emergency state of the network, when the network elements are overloaded, the Uset value can be driven to two lower values defined by the parameters “Voltage Reduction 1” and “Voltage Reduction 2”. “U Set” is decreased by the parameter values if the binary inputs “Voltage Reduction 1” or “Voltage Reduction 2” enter into active state. These inputs must be programmed graphically by the user.

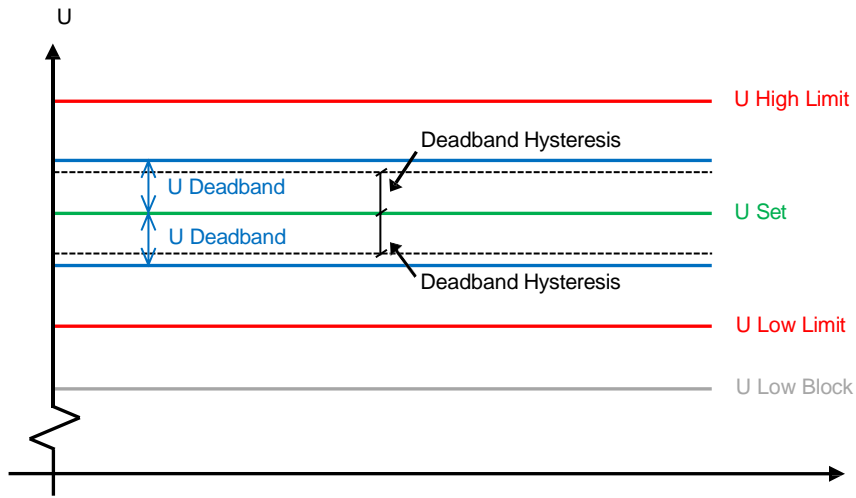

Figure 1-2 Voltage level settings

3.1.3.4.1.2. Time delay in automatic control mode

In automatic control mode the first and every subsequent control command is processed separately.

For the first control command:

The voltage difference is calculated:

$$U_{diff} = |U_{control} - U_{set}|$$

If this difference is above the “U Deadband” value, then depending on the setting of parameter “Time delay 1 type”, three different timing modes can be selected:

- “Definite” this definite time delay is defined by parameter “Time delay 1”, but minimum “Min Delay” time
- “Inverse” standard IDMT characteristic defined by the parameters:
 - “Time delay 1” maximum delay defined by the parameter
 - “U Deadband” is the width of the permitted range in both + and – directions
 - “Min Delay” minimum time delay

$$T_{delay} = \frac{Time\ delay\ 1}{\frac{U_{diff}}{U\ Deadband}}, \text{ but minimum “Min Delay” time}$$

- “2powerN”

$$T_{delay} = (Time\ delay\ 1) * 2^{\left(1 - \frac{U_{diff}}{U\ Deadband}\right)}, \text{ but minimum “Min Delay” time}$$

The binary parameters “Fast Lower Enable” and/or “Fast Higher Enable” enable fast command generation if the voltage is above the parameter value “U High Limit” or below the “U Low Limit”. In this case, the time delay is a definite time delay defined by parameter “Time delay 2”, but minimum “Min Delay” time.

For subsequent control commands:

If the subsequent command is generated within the “Reclaim time” defined by parameter the time delay is always a definite time delay defined by parameter “Time delay 2”, but minimum “Min Delay” time.

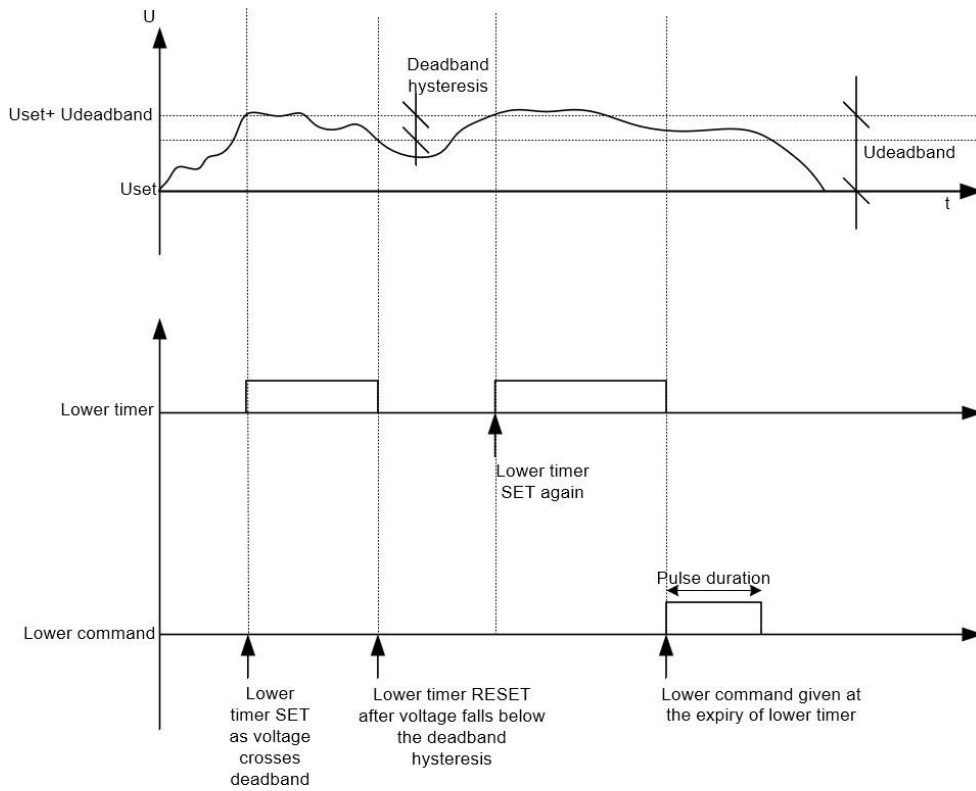

Figure 1-3 Example of command generation sequence to illustrate deadband hysteresis

3.1.3.4.1.3. Time scheduler (for ATCC)

This optional function can be used to provide daylong update of the “U set” value.

Its “Operation” parameter is set to enable to activate the scheduler function.

Each calendar day are divided into seven time intervals where user-defined “U set” value can be applied. Each interval related “U set” value overwrites the “U set” value of the ATCC function when time scheduler function is enabled.

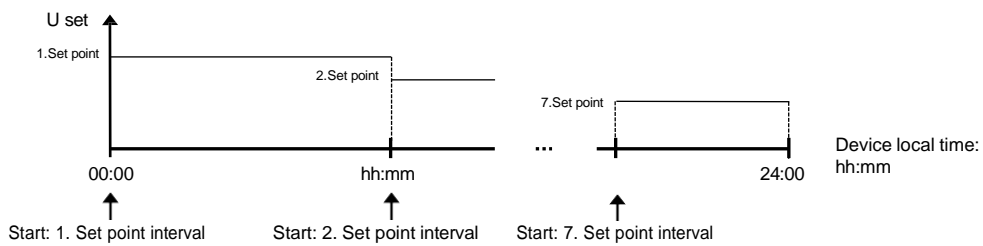

Figure 1-4 Time scheduler function set points and intervals

NOTE: time is based on the device local time (UTC/GMT + GMT offset)

Parameter description of the “Time scheduler (for ATCC)” function can be found in Table 3-3.

3.1.3.4.2. Manual control mode – “MANUAL” module

The tap changer controller receives remote commands from the SCADA system and local commands from the local LCD of the device when Manual mode is selected.

The Manual mode can be selected either the “Auto/Man” control channel (ATCC_Man_Con_) via command or the “Manual” binary input (ATCC_Manual_GrO_) of the function block is TRUE (as configured in the User Logic of the EuroCAP configuration software tool by the user). In manual mode, the automatic control is blocked.

In the remote mode, the “Remote” binary input needs to be in active state as programmed by the user. In this case the manual commands are received by “Operation” control channel (ATCC_Oper_Con_) via the communication interface.

In local mode, the “Local” binary input needs to be in active state as programmed by the user. In this case the manual commands are generated with same controlled channel as mentioned above with the local LCD of the device.

Other manual control option can be performed with the dedicated binary inputs “ManHigher” or “ManLower” which must be configured graphically by the user. It can be used in both Local and Remote modes.

3.1.3.4.3. Command generation and tap changer supervision – “CMD & TC SUPERV.” module

The software module “CMD&TC SUPERV.”, which can be seen in Figure 1-1 is responsible for the generation of the “HigherCmd” and “LowerCmd” command pulses, the duration of which is defined by the parameter “Pulse Duration”. This is valid both for manual and automatic operation.

3.1.3.4.3.1. Tap changer position

The tap changer supervision function receives the information about the tap changer position either in six bits of the binary inputs “Bit0 to Bit5” or via mA input (mA input decoding is ordering option with an additional AIC+/0202 module).

The six bits of the binary inputs value is decoded according to the enumerated parameter “CodeType”, the values of which can be: Binary, BCD, Gray or mA.

If mA decoding is applied the “CodeType” parameter has to be set to “mA” and additional function block “TCPos Transducer Input” (StepmA) needs to be integrated into the configuration. “TCPos Transducer Input” function block provides the mA input decoding pre-process to the automatic tap changer controller function. Note, that during the decoding process the stepmA function supervises the magnitude of the received mA signal. The magnitude of the received mA signal must be within the $\pm 45\%$ range of the nominal mA value of the related tap position to avoid fluctuation between neighboring positions. This $\pm 45\%$ range is related to the exact mA value range between two neighboring positions. If the received magnitude is between two valid range, the tap position is not defined and the tap position shows 0 value. (The range is $\pm 40\%$ instead of $\pm 45\%$ with earlier RDSP firmware versions than rev. 2.8.13.2080-H2.)

During switchover, for the transient time defined by the parameter “Position Filter”, the position is not evaluated.

Table 1-1 Parameters of the “TCPos Transducer Input” function

TITLE	DIM	RANGE	STEP	DEFAULT	EXPLANATION
Input Low	mA	-20 – -5	1	4	Minimum value for the current
Input High	mA	5 – 20	1	20	Maximum value for the current
MinStep	-	1 – 32	1	1	Minimum value for scaling
MaxStep	-	1 – 32	1	27	Maximum value for scaling

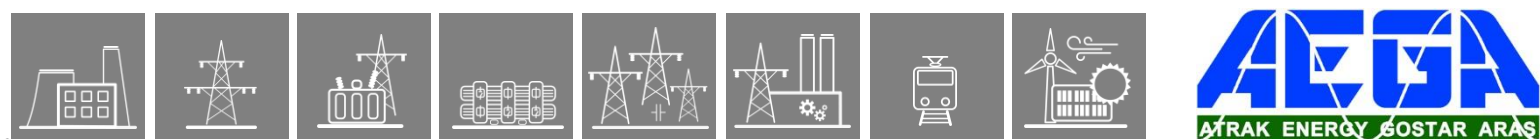

The parameters “Min Position” and “Max Position” define the upper and lower limits. In the upper position the output “Max Pos Reached” becomes active and if the “TC Supervision” parameter is set to either “Position” or “Both”, no further increasing command is generated. Similarly, in the lower position, no further decreasing command is generated if the “TC Supervision” parameter is set as written above and the output “Min Pos Reached” becomes active.

3.1.3.4.3.2. Supervision of the tap changer operation

The function also supervises the operation of the tap changer. Depending on the setting of parameter “TC Supervision”, three different modes can be selected:

- “TCDrive” the supervision is based on the input “TCRun”. In this case, after command generation the drive is expected to start operation within one quarter of the value defined by the parameter “Max Operating Time” and it is expected to perform the command within “Max Operating Time”
- “Position” the supervision is based on the tap changer position in six bits of the binary inputs “Bit0 to Bit5”. It is checked if the tap position is incremented in case of a voltage increase, or the tap position is decremented in case of a voltage decrease, within the “Max Operating Time”.
- “Both” in this mode the previous two modes are combined.

In case of an error detected in the operation of the tap changer, the “Locked” output becomes active and no further commands are performed. To enable further operation, the input “Reset” must be programmed for an active state trigger by the user.

3.1.3.4.3.3. Error codes of the operation of the tap changer

The On-line information includes a variable "ErrorCode" (ATCC_ErrCode_ISt_), indicating different error states. These states are binary coded; any of them causes “Locked” state of the controller function. The explanation of the individual bits in the code value is explained in the Table below. In case of multiple error states the values are added in the "ErrorCode".

Table 1-2 “ErrorCode” Table

BIT	VALUE	EXPLANATION
0	1	Drive started without control command
1	2	Drive did not start after control command
2	4	Drive did not stop in due time
3	8	Invalid position signal
4	16	Position signal did not change value

3.1.3.5. Automatic tap changer controller function overview

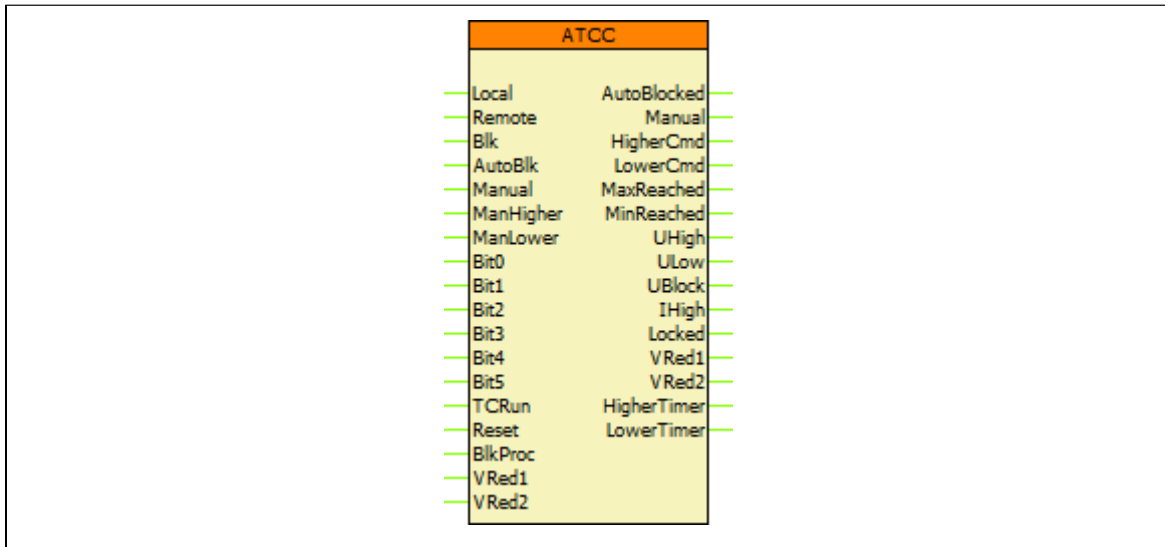

Figure 2-1 Graphic appearance of the function block of automatic tap changer controller

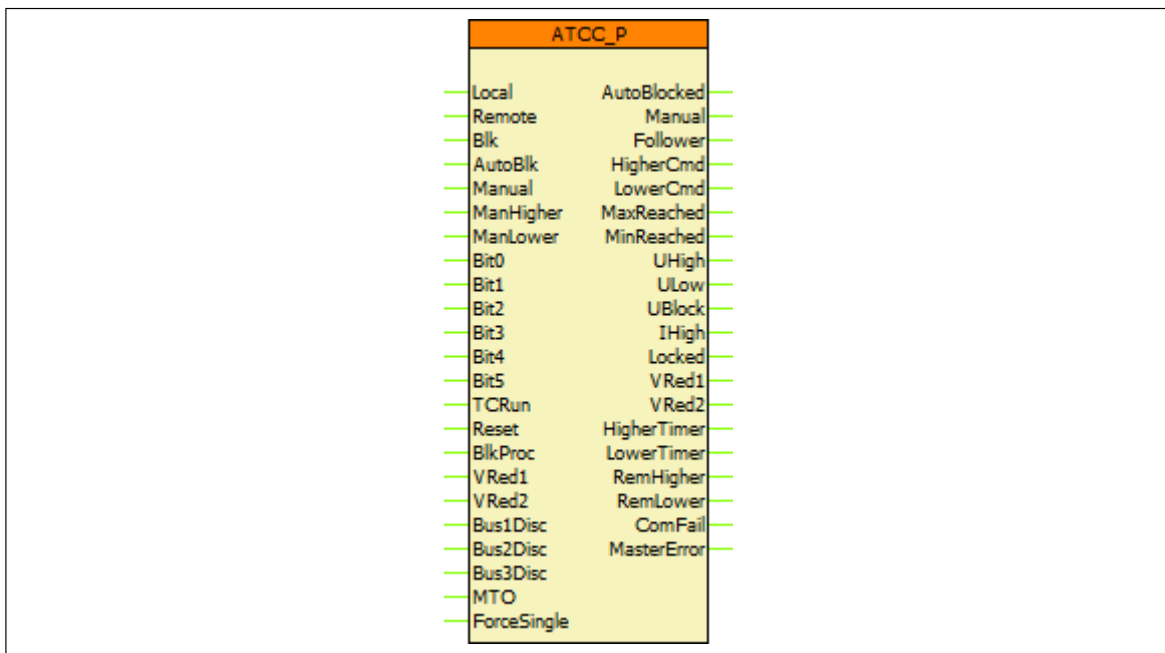

Figure 2-2 Graphic appearance of the function block of automatic tap changer controller for parallel transformers



3.1.3.6. Mode of operation to control parallel transformers

This mode of operation is selected if the “Operation” parameter is set to one of the following values:

- *Single* mode with special setting of the voltage compensation can be performed **negative reactance circulating current control**
- *Min Circulating Current*, for selecting the controllers of the parallel connected transformers to **minimize circulating current control**;
- *Master*, for selecting one of the controllers of the parallel connected transformers to be the master, to transmit commands to the slave controllers in **master slave control**;
- *Slave-Cmd*, for selecting the controller to operate in slave mode, and follow the UP and DOWN commands;
- *Slave-Tap*, for selecting the controller to operate in slave mode, and drive the tap changer to the same position as the transformer assigned to the master controller.

Up to 4 transformers may be involved. Individual EuroProt+ controllers are assigned to each of them, and these devices co-operate with each other. The method of co-operation depends on the selected mode, as set by the “Operation” parameter.

Usually the devices must be connected to the same Ethernet communication network, characterized with the same “GroupID”. This must be selected by parameter setting, identical for the co-operating devices. The “Device Address” must be set unique for the devices within the group, for two transformers “0” and “1”, etc. The “GroupID” can be applied also for VLAN identifier. To do this, the parameter “UseVLAN” must be set to logic “1”.



EuroProt+ CPU+xxxx module SB (station bus) ports can be used to establish the communication network among the cooperating tap changer controller devices.

The messages sent via Ethernet network are similar multicast messages to the GOOSE messages according to the IEC 61850 communication standard, but they are device specific commands. The MAC address of these multicast messages is 01-0C-CD-07-“GroupID”.

3.1.3.6.1. Minimizing circulating currents control mode

This mode of operation is selected if the “Operation” parameter is set to “Min Circulating Current”.

To perform the related algorithm, communication is needed among the controllers. The co-operating controllers must be identified by each device, by checking the parameters “Address 0 InUse”, “Address 1 InUse”, “Address 2 InUse”, “Address 3 InUse”. For minimizing the circulating current, the following information is needed from each co-operating devices:



- Calculated voltage drop (U_{di} see below),
- Current real and imaginary components (relative to the common bus voltage),
- $S_n / \{ \text{Short circuit impedance} \}$, calculated internally from parameters “Transformer S_n ” and “Transformer short circuit impedance”.
- Connected or disconnected state of the transformer to the busbar of the regulated voltage level.

Based on this information the current vectors are transformed into a common coordinate system defined by the common voltage vector. The sum of these currents is the total load current:

$$I_L = \sum_i I_{Ti}$$

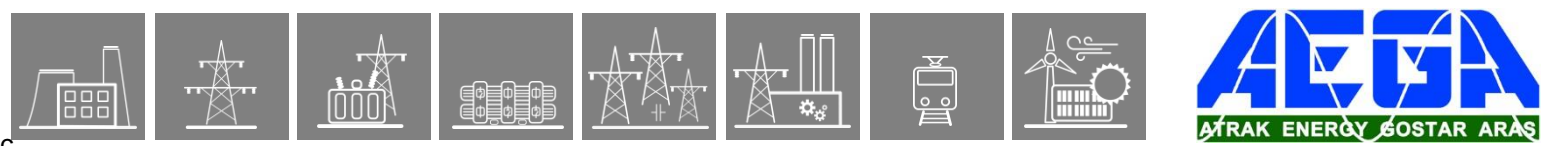

The transformers disconnected from the busbar of the regulated voltage level are not involved in this calculation.

The current, according to the impedance relationship is calculated by:

$$I_{Li} = \frac{\frac{S_{ni}}{\varepsilon_i}}{\sum_j \frac{S_{nj}}{\varepsilon_j}} I_L$$

The difference of the measured I_{Ti} current and the current I_{Li} due to the current division is the circulating current:

$$I_{Cci} = I_{Ti} - I_{Li}$$

This circulating current causes a voltage drop, which is equivalent to the voltage difference caused by the tap changer position:

$$U_{di} = \text{Im}(I_{Cci}) * \frac{\varepsilon_{iContr} U_{ni}^2}{100 S_{ni}}$$

In this formula a special short circuit impedance value is applied: ε_{iContr} called “control short circuit impedance”, and can be set as parameter “Control short circuit impedance”. If this value is set different as compared with the setting value of the parameter “Transformer short circuit impedance” then the calculated effect of the circulating current can be influenced.

With this U_{di} voltage drop, the measured busbar voltage U_B to be controlled is modified:

$$U'_B = U_B - U_{di}$$

Based on the calculated U_{di} voltage drops, the controller with the highest U_{di} calculated value starts generating the required control command, the operation of all other controllers are delayed. This method prevents the possibility to regulate quickly up and down subsequently, due to the mutual influence of tap-changer operations.

3.1.3.6.2. Negative reactance circulating current control mode

Negative reactance circulating current control mode can be provide effective solution to control power transformers in any configuration, in parallel at a site, even across a network, because no communication is requested among the tap changer controllers.

The negative value of reactance with voltage compensation mode (see Paragraph 1.4.1) settings is used to control the tap positions of parallel transformers to be similar to minimize the circulating current.

The following equations show the connection between the voltage drop compensation and the negative reactance circulating current setting:

$$Z_{voltage\ drop\ compensation} = (R)CompoundFactor + jXCompoundFactor)$$

$$Z_{negative\ reactance\ circulating\ current} = (R)CompoundFactor - jXCompoundFactor)$$

In the negative reactance method the circulating current is minimized by changing the control voltage according to:

$$U'_B = U_{bus} - [(IL1L2_{Re} + jIL1L2_{Im}) * ((R)CompoundFactor - jXCompoundFactor)]$$

So the negative reactance method uses the line drop compensation method (LDC) with a negative reactance value, being the resistance value equal to zero.

This modified busbar voltage is applied as the $U_{control}$ voltage in Paragraph 1.4.1, and using this value, the controller perform the task as if the transformer would be alone. The result of this mode of operation is that additionally to the required control of the load center voltage, the circulating current is minimized.

Negative reactance circulating current control mode can be set with the following parameters easily:



- “Operation” parameter of the tap changer controller function is set to “**Single**”.,
- “Compensation” parameter is set to “**Complex**”.,
- “(R) Compound Factor” and “X Compound Factor” are set according to the equations above.

3.1.3.6.3. Master slave control mode

This mode of operation is selected if the “Operation” parameter of one of the co-operating devices is set to “Master” and for all other devices it is set either to “SlaveCmd” or to “SlaveTap”. (The not consistent setting is signaled as setting error.)



By selecting Master slave mode, the “Device Address” parameter of the “Master” tap changer controller device must be set to lower value than the “Slave” controller.

In this mode of operation, the master is controlling the assigned transformer, as if it would be alone, and transmits the HIGHER and LOWER commands and the tap changer position to the slaves.

The slave devices react according to the parameter setting.



In master slave mode of operation both auto and manual control commands of master device are forwarded to the slave devices and the slave devices control their own tap changers according to the received commands if the slave devices are set to auto mode.

Operation in “SlaveCmd” mode

If all slave’s “Operation” parameter is set to “SlaveCmd” mode then the master device transmits the HIGHER or LOWER commands, received via Ethernet connection from the master, without comparing the tap changer position. If the initial state of all tap-changers assures the operation of the system without any circulating currents, and the appropriate tap steps generate the same voltage regulation then this mode can be applied. If there is a single failure in the operation of any of the tap-changers then the error is not corrected automatically.

Operation in “SlaveTap” mode

If all slave’s “Operation” parameter is set to “SlaveTap” mode, then the master device transmits the own tap position as the required tap position for all co-operating controllers. The slave devices generate the appropriate commands until this required position is reached. If the tap position of a slave is identical with that of the master then the subsequent operation is performed according to the rule of the “SlaveCmd” mode.

There is a correction possibility for tap position adjustment, if the tap-changers are not of the same type: the parameter setting “Tap Offset” can match the parallel running of the individual tap-changers

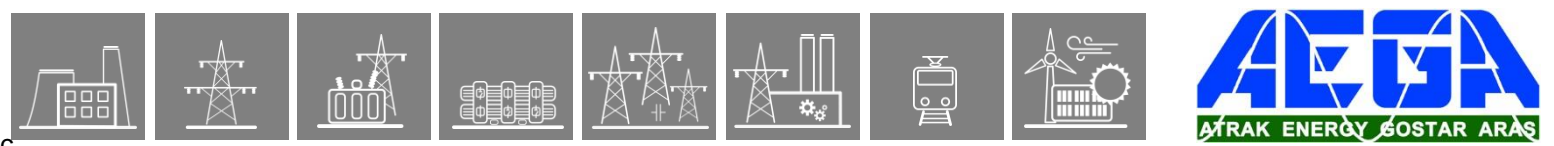

3.1.3.6.4. Forced modes of operation

In case of intentional user action or certain errors the algorithm can override the mode of operation defined by parameter setting as follows:

- **Forced “Single” mode**

Intentional user action:

The mode of operation is changed to “Single mode” when the ATCC_**ForceSingle**_GrO_ binary inputs of the parallel tap changer controller function block is active.

Errors:

The mode of operation is changed to “Single mode” and at the same time the operation is disabled in case of any of the following errors:

- Contradiction in addresses
 - Topology error:
 - It may arise if the controlled transformer is not connected to any of bus sections or connected to more than one bus section (any of the ATCC_**Bus1-3Disc**_GrO_ (Bus1-3Disc) binary inputs of the tap changer controller function block is not active or more than one is active).
 - If the device set to “Master” mode finds another master with higher priority connected to the same bus section
 - In “Min Circulating Current” mode the voltage measurement is missing
- **Forced “Master” mode**

The slave with the highest priority can enter to this mode of operation, if the “MTO” input is active and the former Master is not available.

The device displays the actual mode of operation in the “On-line” menu of the LCD and in the WEB interface as well.

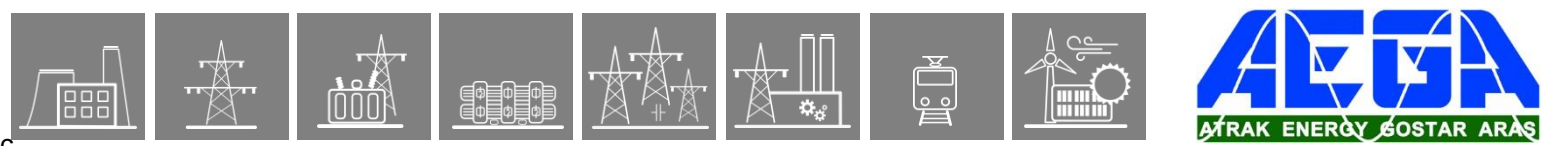

3.1.3.6.5. Operation in case of errors

For proper operation the following conditions must be fulfilled:

- The devices to control parallel transformers must be connected to the same Ethernet network,
- The status signals indicating the busbar configuration must be correct (the automatic tap changer controllers which are operating in parallel must be connected to same bus section (must be connected to the same ATCC_**Bus1-3Disc**_GrO_ (Bus1-3Disc) binary input of the tap changer controller function block).
- Also the parameter setting of the co-operating controllers must be correct.

In case of any errors the “On-line” window of the controller function shows an error code. The configured code vales of the “Parallel error” field are summarized in the Table below:

Table 3-1 “Parallel error” code values

ERROR CODE (DECIMAL)	ERROR CODE (HEXA)	EXPLANATION
0	0x0	No error
1	0x1	There is no interconnection with the device on address 0
2	0x2	There is no interconnection with the device on address 1
4	0x4	There is no interconnection with the device on address 2
8	0x8	There is no interconnection with the device on address 3
256	0x100	Invalid address
512	0x200	Master error (indicated by the slave device): No master controller can be found by the slave device.
1024	0x400	Error in the topology (e.g. a transformer seems to be connected to more than one bus section)
2048	0x800	There is another master with higher priority in the system (indicated by the master device)
4096	0x1000	Address error (more then one device with the same address)

In case of multiple errors, the assigned code values are added.

The devices are blocked in “Min Circulating Current” mode if the communication fails with any of the co-operating devices, or any of them is blocked.

3.1.3.7. Settings

3.1.3.7.1. Parameters

Table 3-2 The measured analogue values of the automatic tap changer controller function

TITLE	DIM.	RANGE	STEP	DEFAULT	EXPLANATION
Operation	-	Off, Single (On), Min. Circulating Current, Master, Slave-Cmd, Slave-Tap	-	Off	Parameter for general operation of the function: Single, Min. Circulating Current, Master, Slave-Cmd, Slave-Tap are valid only in automatic tap changer controller for parallel transformers function.
TC Supervision	-	Off, TCDrive, Position, Both	-	Off	Tap changer supervision mode selection
Code Type	-	Binary, BCD, Gray, *mA	-	Binary	Decoding of the position indicator bits *mA: this option is only available if mA decoding has been ordered for tap changer position decoding
Min Position	-	1-32	1	1	Code value of the minimum position
Max Position	-	1-32	1	32	Code value of the maximum position
I Overload	%	50 – 150	1	150	Current upper limit to disable all operation.
Max Operating Time	msec	1000 – 30000	1	5000	Time limit for tap-change operation
Pulse Duration	msec	100 – 10000	1	1000	Command impulse duration
Position Filter	msec	1000 – 10000	1	3000	Time of overbridging the transient state of the tap changer status signals which the status is not evaluated
Time delay 1 type	-	Definite, Inverse, 2powerN	-	Definite	Parameter for time delay mode selection
Compensation	-	Off, Absolute, Complex	-	Off	Selection for compensation mode
Fast Higher Enable	-	FALSE,TRUE	-	FALSE	Enabling fast higher control command
Fast Lower Enable	-	FALSE,TRUE	-	FALSE	Enabling fast lower control command
U Correction		0.950 – 1.050	0.001	1.000	Factor for fine tuning the measured voltage
U Set	%	80.0 – 115.0	0.1	100.0	Set-point for voltage regulation, related to the rated voltage (Valid at I=0)

Device Address	-	0 – 3	-	3	Device address within the group of cooperating controllers
Tap Offset	-	-5 – 5	-	0	Setting the tap offset position in master-slave “SlaveTap” mode
Transformer Drop	%	1.0 – 30.0	0.1	5	Transformer short circuit impedance for the circulating current mode of operation
Transformer Sn	MVA	1.0 – 500.0	0.1	40	Transformer rated power for the circulating current mode of operation
Control Drop	%	1.0 – 50.0	0.1	10	Short circuit impedance for weighting the influence of the circulating current for the circulating current mode of operation
ControlModel	-	Direct normal, Direct enhanced, SBO enhanced	-	Direct normal	Control model, according to IEC 61850 standard
sboClass	-	Operate-once, Operate-many	-	Operate-once	Select before operate class, according to IEC 61850 standard
SBO Timeout	msec	1000 – 20000	1	5000	Duration of the waiting time between object selection and command selection. At timeout no command is performed

Table 3-3 The parameters of the time scheduler (for ATCC) function

TITLE	DIM.	RANGE	STEP	DEFAULT	EXPLANATION
Operation	-	Disable,Enable	-	Disable	Activation of the time scheduler function
1.Set point (from 0:00)	%	80.0 - 115.0	0.1	100	“U set” value during 1. Set point interval
2.Interval Start	Hour	0 - 23	1	7	2.Interval Start hour
2.Interval Start	Minute	0 - 59	1	1	2.Interval Start minute
2.Set point	%	80.0 - 115.0	0.1	100	“U set” value during 2. Set point interval
...
7.Interval Start		0 - 23		22	7.Interval Start hour
7.Interval Start		0 - 59		1	7.Interval Start minute
7.Set point		80.0 - 115.0		100	“U set” value during 7. Set point interval

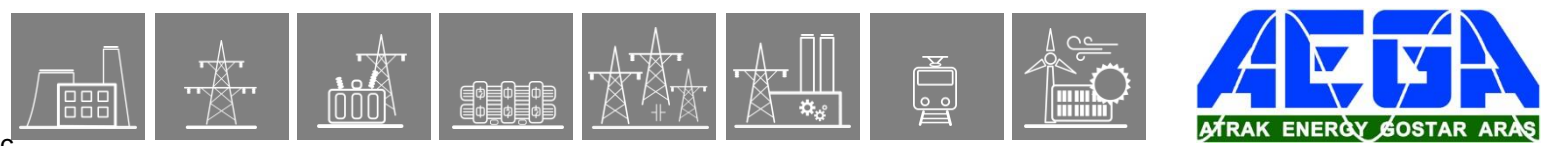

3.1.3.8. Function I/O

This section describes briefly the analogue and digital inputs and outputs of the function block.

3.1.3.8.1. Analogue inputs

The function uses the sampled values of the three phase currents of each side.

3.1.3.8.2. Analogue outputs (measurements)

The measured values of the automatic tap changer controller function are listed in the table below.

Table 3-4 The measured analogue values of the automatic tap changer controller function

MEASURED VALUE	DIMENSION	EXPLANATION
U Bus	Un %	<i>UL1L2 voltage</i>
U Controlled	Un %	<i>UL1L2 compensated by the current of the controlled side IL1L2</i>
I Circulating reactive	In %	Circulating reactive current in parallel transformer operation

3.1.3.8.3. Binary input signals (graphed output statuses)

The conditions of the inputs are defined by the user, applying the graphic equation editor (logic editor). The part written in **bold** is seen on the function block in the logic editor.

Table 3-5 The binary input signal of the automatic tap changer controller function

Binary status signal	Title	Explanation
ATCC_Local_GrO_	Local	Local state of the manual operation
ATCC_Remote_GrO_	Remote	Remote state of the manual operation
ATCC_BlK_GrO_	Blk	Blocking of the function
ATCC_AutoBlk_GrO_	AutoBlk	Blocking of the automatic function
ATCC_Manual_GrO_	Manual	Manual mode of operation
ATCC_ManHigher_GrO_	ManHigher	Manual command for increasing the voltage
ATCC_ManLower_GrO_	ManLower	Manual command for decreasing the voltage
ATCC_Bit0_GrO_	Bit0	Bit 0 of the position indicator
ATCC_Bit1_GrO_	Bit1	Bit 1 of the position indicator
ATCC_Bit2_GrO_	Bit2	Bit 2 of the position indicator
ATCC_Bit3_GrO_	Bit3	Bit 3 of the position indicator
ATCC_Bit4_GrO_	Bit4	Bit 4 of the position indicator
ATCC_Bit5_GrO_	Bit5	Bit 5 of the position indicator
ATCC_TCRun_GrO_	TCRun	Running state of the tap changer
ATCC_Reset_GrO_	Reset	Reset to release from blocked state
ATCC_BlKProc_GrO_	BlkProc	Blocking signal from the tap changer
ATCC_VRed1_GrO_	VRed1	Reduced voltage 1 is required
ATCC_VRed2_GrO_	VRed2	Reduced voltage 2 is required
Extension for automatic tap changer controller of parallel transformers		
ATCC_Bus1Disc_GrO_	Bus1Disc	Disconnecter closed for Bus1



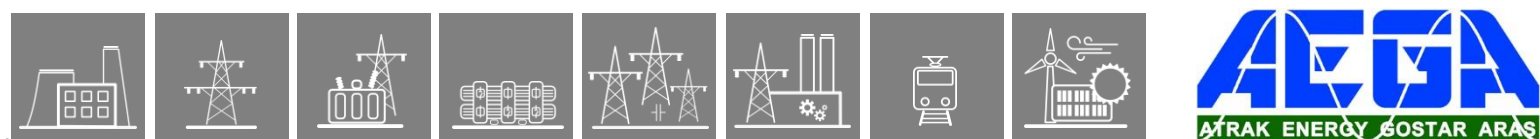

3.1.3.8.5. On-line data

Visible values on the on-line data page:

Table 3-7 On-line data of the automatic tap changer controller function

SIGNAL TITLE	DIMENSION	EXPLANATION
U Bus	%	UL1L2 voltage
U Controlled	%	UL1L2 compensated by the current of the controlled side IL1L2
Position	-	Tap changer position
Error Code	-	Error codes of the operation of the tap changer based on the Table 1-2 "ErrorCode" Table
Remote Tap Position	-	In Master-Slave mode receiving the Master tap position
Min Pos Reached	-	Signaling the minimal position
Max Pos Reached	-	Signaling the maximal position
Higher Command	-	Command feedback for increasing the voltage
Lower Command	-	Command feedback for decreasing the voltage
U High	-	Controlled side UL1L2 exceeds the "U High Limit" parameter value, more details in Chapter 1.3
U Low	-	Controlled side UL1L2 goes under the "U Low Limit" parameter value, more details in Chapter 1.3
U Block	-	Controlled side UL1L2 goes under the "U Low Block" parameter value, more details in Chapter 1.3
I High	-	IHV (load side) is above the limit set by the parameter "I Overload", more details in Chapter 1.3
Locked	-	In case of an error detected in the operation of the tap changer and no further commands are performed. See Chapter 1.4.3
Higher Timer	-	Timer running to indicate higher command
Lower Timer	-	Timer running to indicate lower command
Auto Blocked (ext)	-	Automatic control blocked
Voltage Reduction 1	-	Voltage Reduction 1 is active
Voltage Reduction 2	-	Voltage Reduction 2 is active
Manual	-	Manual mode of operation is active
Extension for automatic tap changer controller of parallel transformers		
I Circulating reactive	%	Circulating reactive current in parallel transformer operation (% based on IL1L2 nominal current)
Follower	-	Follower control mode is active. See Chapter 1.4.1
Parallel error	-	Indicated the error code of parallel operation. See Chapter 3.1.5
Actual mode	-	Actual mode of operation
Remote Higher	-	Received command from the remote master tap changer controller device



Remote Lower	-	Received command from the remote master tap changer controller device
Communication Error	-	Communication error in parallel operation. See Chapter 3.1.5
Master Error	-	The slave device can not follow the master

3.1.3.8.6. Events

The following events are generated in the event list, as well as sent to SCADA according to the configuration.

Table 3-8 Events of the automatic tap changer controller function

EVENT	VALUE	EXPLANATION
Min Pos Reached	off,on	Minimum position reached
Max Pos Reached	off,on	Maximum position reached
ATCC local mode	off,on	Local mode of tap changer controller is active
AutoMode	off,on	Auto mode of operation
Blocked	off,on	Tap changer control is blocked
Voltage Reduction 1	off,on	Controlling to reduced voltage 1
Voltage Reduction 2	off,on	Controlling to reduced voltage 2
Higher Command	off,on	Higher command generated
Lower Command	off,on	Lower command generated
U Block	off,on	U Block condition is active. See Chapter 1.3
U High	off,on	U High condition is active. See Chapter 1.3
U Low	off,on	U Low condition is active. See Chapter 1.3
I High	off,on	I High condition is active. See Chapter 1.3
Locked	off,on	Locked state is active. See Chapter 1.4.3
Extension for automatic tap changer controller of parallel transformers		
Actual Mode	Off,Single,Min Circulating, Master,Slave-Cmd,Slave-Tap.	Actual mode of tap changer controller
Communication Error	off,on	Communication error in parallel operation. See Chapter 3.1.5



Commands

The following table contains the issuable commands of the function block. The name of the command channel is used while working in the EuroCAP configuration tool, whereas the title is seen by the user on the device web page.

Table 3-9 The command of the automatic tap changer controller function

COMMAND CHANNEL	TITLE	RANGE	EXPLANATION
ATCC_Oper_Con_	Operation	Lower,Higher	Manual higher/lower command of automatic tap changer controller
ATCC_BlK_Con_	Blocking	Enabled,Blocked	Blocking command of automatic tap changer controller
ATCC_VRed1_Con_	Voltage Reduction 1	Back,Reduction	Command to reduced set-point 1 for voltage regulation (priority), related to the rated voltage
ATCC_VRed2_Con_	Voltage Reduction 2	Back,Reduction	Command to reduced set-point 2 for voltage regulation, related to the rated voltage
ATCC_Man_Con_	Auto/Man	Auto,Manual	Command to change the mode of operation of tap changer

3.1.3.9. Technical data

Table 3-10 Technical data of the automatic tap changer controller function

FUNCTION	RANGE	ACCURACY
Voltage measurement	$50 \% < U < 130 \%$	<1%
Definite time delay		<2% or ± 20 ms, whichever is greater
Inverse and "2powerN" time delay	$12 \% < \Delta U < 25\%$	<5%
	$25 \% < \Delta U < 50\%$	<2% or ± 20 ms, whichever is greater

3.2. Control & supervision functions

3.2.1. Circuit breaker wear monitoring function

If a circuit breaker interrupts a current, the electric arc between the contacts results some metal loss. If the metal loss due to the burning of the electric arc becomes substantial, the contacts must be replaced.

Manufacturers define the permitted number of short circuits by formulas such as:

$$\sum_{i=1}^n I_i^k = CycNum$$

where

n = number of short circuits

k = exponent, calculated by the algorithm, based on the parameters I = short-circuit current, kA (RMS)

CycNum = total value of weighted breaking currents.

Similar information is conveyed by the diagram below. This shows the number of permitted interruptions (logarithmic scaling) versus short-circuit current (logarithmic scaling) that the contacts in a circuit breaker can manage before the metal loss due to burning becomes so significant that the contacts must be replaced.

Number of interruptions

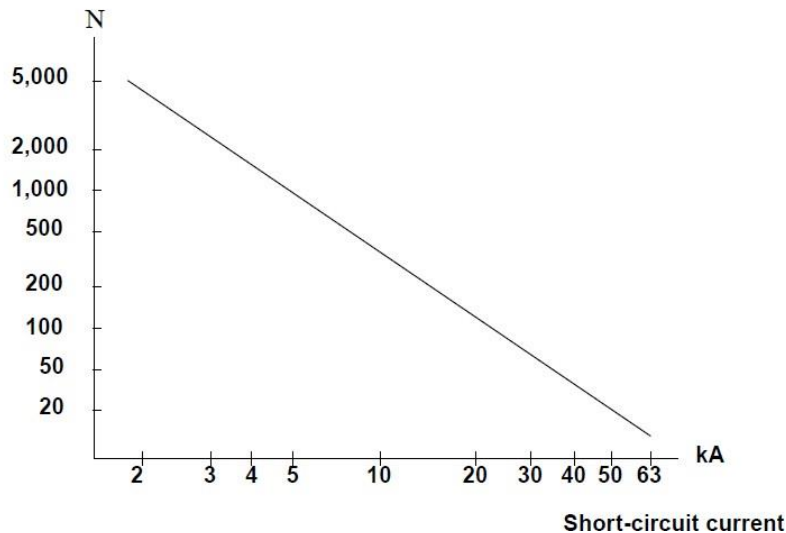

Figure 1-1 Example: Number of permitted interruptions as the function of the interrupted current

The straight line of the curve is defined by two points:

- The number of permitted interruptions of 1 kA current (CycNum - 1kA)
- The number of permitted interruptions of the rated breaking current of the circuit breaker (CycNum – I Rated Trip).

The circuit breaker wear monitoring function finds the maximum value of the phase currents of each interruption and calculates the wear caused by the operation performed. If the sum of the calculated wear reaches the limit, a warning signal is generated. This indicates the time of the required preventive maintenance of the circuit breaker.



3.2.1.1. Operation of the circuit breaker wear monitoring algorithm

The operating principle of the circuit breaker wear monitoring function is based on curves similar to the one shown in [Figure 1-1](#). With this figure, the manufacturer of the circuit breaker defines the permitted total number of current interruptions up to the subsequent preventive maintenance.

The straight line of the curve is defined by two points:

- The number of interruptions of 1 kA current, by parameter `CBWear_CycNumIn_IPar_` (`CycNum - 1kA`)
- The number of interruptions of the rated breaking current of the circuit breaker by parameter `CBWear_CycNumInTrip_IPar_` (`CycNum - I Rated Trip`). The rated breaking current of the circuit breaker is set by parameter `CBWear_InTrCB_FPar_` (`Rated Trip Current`)

The circuit breaker wear monitoring function processes the Fourier basic harmonic component of the three phase currents.

The circuit breaker wear monitoring function identifies the highest value of the phase currents at each interruption.

The procedure of monitoring starts at the receipt of a trip command on the dedicated input (`Trip`). For the start of this procedure, the circuit breaker also needs to be in closed state. This signal is received on the dedicated binary input (`CB Closed`).

The procedure of identifying the maximum phase current value terminates when the current falls below the minimum current defined by the parameter `CBWear_Imin_FPar_` (`Min Current`) AND the circuit breaker gets in open position. This signal is received on the dedicated binary input (`CB Open`).

The procedure also stops if the time elapsed since its start exceeds 1 s. In this case no CB wear is calculated.

Based on the characteristic defined above, the function calculates the wear caused by the operation performed. If the sum of the calculated wear reaches the limit defined by the parameter `CBWear_CycNumAlm_IPar_` (`CycNum - Alarm`), a warning signal is generated (`Alarm`). This indicates the advised time of the preventive maintenance of the circuit breaker.

The accumulated “wear” of the circuit breaker is stored on non-volatile memory; therefore, the value is not lost even if the power supply of the devices is switched off.

This information is displayed among the on-line data as “Actual wear”. This counter indicates how many 1 kA equivalent switches were performed since the last maintenance (reset).

When preventive maintenance is performed, the accumulated “wear” of the circuit breaker must be reset to 0 to start a new maintenance cycle. The circuit breaker wear monitoring function offers two ways of resetting:

- Binary True signal programmed to the “Reset” input of the function
- Performing a direct command via the Commands menu of the supervising WEB browser (for details, see the “Europrot+ manual”, “Remote user interface description” document). The Command window looks like [Figure 1-2](#).



Figure 1-2 The command window to reset the CB wear counter

The **inputs** of the circuit breaker wear monitoring function are

- the Fourier components of three phase currents,
- binary inputs,
- parameters.

The **output** of the circuit breaker wear monitoring function is

- the Alarm binary output status signal.

3.2.1.2. Technical summary

3.2.1.2.1. Technical data

Function	Range	Accuracy
Current accuracy	20 – 2000% of I_n	$\pm 1\%$ of I_n
Accuracy in tracking the theoretical wear characteristics		5%

Table 1-1 Technical data of the circuit breaker wear monitoring

3.2.1.2.2. Summary of the parameters

The parameters of the circuit breaker wear monitoring function are explained in the following tables.

Enumerated parameter

Parameter name	Title	Selection range	Default
Disabling or enabling the operation of the function			
CBWear_Oper_EPar_	Operation	Off,On	Off

Table 1-2 The enumerated parameter of the circuit breaker wear monitoring function

Integer parameters

Parameter name	Title	Unit	Min	Max	Step	Default
Permitted number of trip operation if the breaking current is 1kA						
CBWear_CycNumIn_IPar_	CycNum - 1kA		1	100000	1	50000
Permitted number of trip operation if the breaking current is InTrip (See floating parameter "Rated Trip Current")						
CBWear_CycNumInTrip_IPar_	CycNum – I Rated Trip		1	100000	1	100
Permitted level of the weighted sum of the breaking currents						
CBWear_CycNumAlm_IPar_	CycNum - Alarm		1	100000	1	50000

Table 1-3 The integer parameters of the circuit breaker wear monitoring function

Floating point parameters

Parameter name	Title	Unit	Min	Max	Step	Default
Rated breaking current of the circuit breaker						
CBWear_InTrCB_FPar_	Rated Trip Current	kA	10	100	0.01	10
Minimum level of the current below which the procedure to find the highest breaking current is stopped						
CBWear_lmin_FPar_	Min Current	kA	0.10	0.50	0.01	0.10

Table 1-4 The floating-point parameters of the circuit breaker wear monitoring function

3.2.1.2.3. Binary output status signals

The **binary output status signals** of the circuit breaker wear monitoring function.

Binary output signals	Signal title	Explanation
Alarm signal of the function block		
CBWear_Alarm_GrI_	Alarm	Alarm signal is generated if the weighted sum of the breaking currents is above the permitted level

Table 1-5 The binary output status signal of the circuit breaker wear monitoring function

3.2.1.2.4. The binary input status signals

The **binary inputs** are signals influencing the operation of the circuit breaker wear monitoring function. These signals are the results of logic equations graphically edited by the user.

Binary input signals	Signal title	Explanation
Disabling the function		
CBWear_BlK_GrO_	Blk	The programmed True state of this input disables the operation of the function
Open state of the circuit breaker		
CBWear_Open_GrO_	Open	The open state of the circuit breaker is needed to stop the procedure to find the maximum breaking current
Closed state of the circuit breaker		
CBWear_Closed_GrO_	Closed	The closed state of the circuit breaker is needed to perform the procedure to find the maximum breaking current



Trip command to the circuit breaker		
CBWear_Trip_GrO_	Trip	This signal starts the procedure to find the highest breaking current
Reset command		
CBWear_Reset_GrO_	Reset	If this input is programmed to logic True, at maintenance the weighted sum of the breaking currents can be set to 0

Table 1-6 The binary input signals of the circuit breaker wear monitoring function

3.2.1.2.5. The function block

The function block of the circuit breaker wear monitoring function is shown in [Figure 1-3](#). This block shows all binary input and output status signals that are applicable in the graphic equation editor.

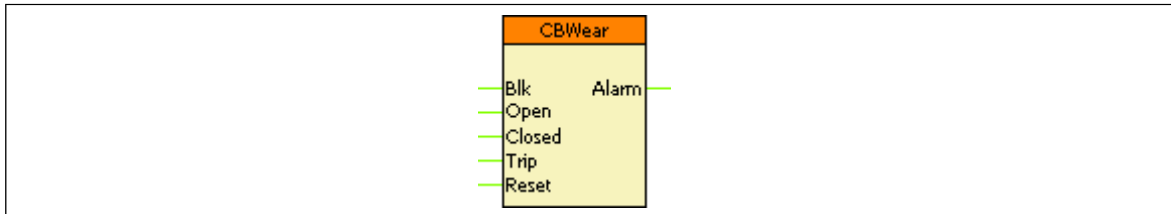

Figure 1-3 The function block of the circuit breaker wear monitoring function



3.2.2. Circuit breaker control function block

3.2.2.1. Application

The circuit breaker control block can be used to integrate the circuit breaker control of the EuroProt+ device into the station control system and to apply active scheme screens of the local LCD of the device.

3.2.2.1.1. Mode of operation

The circuit breaker control block receives remote commands from the SCADA system and local commands from the local LCD of the device, performs the prescribed checking and transmits the commands to the circuit breaker. It processes the status signals received from the circuit breaker and offers them to the status display of the local LCD and to the SCADA system.

Main features:

- Local (LCD of the device) and Remote (SCADA) operation modes can be enabled or disabled individually.
- The signals and commands of the synchro-check / synchro-switch function block can be integrated into the operation of the function block.
- Interlocking functions can be programmed by the user applying the inputs “EnaOff” and “EnaOn”, using the graphic equation editor.
- Programmed conditions can be used to temporarily disable the operation of the function block using the graphic equation editor.
- The function block supports the control models prescribed by the IEC 61850 standard.
- All necessary timing tasks are performed within the function block:
 - Time limitation to execute a command
 - Command pulse duration
 - Filtering the intermediate state of the circuit breaker
 - Checking the synchro-check and synchro-switch times
 - Controlling the individual steps of the manual commands
- Sending trip and close commands to the circuit breaker (to be combined with the trip commands of the protection functions and with the close command of the automatic reclosing function; the protection functions and the automatic reclosing function directly gives commands to the CB). The combination is made graphically using the graphic equation editor
- Operation counter
- Event reporting

3.2.2.2. Circuit Breaker control function overview

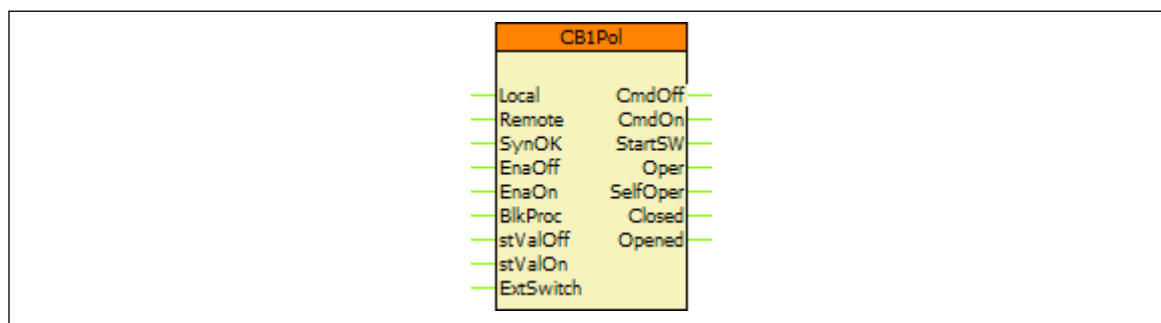

Figure 2-1 Graphic appearance of the function block of the circuit breaker control function

3.2.2.3. Settings

3.2.2.3.1. Parameters

TITLE	DIM	RANGE	STEP	DEFAULT	EXPLANATION
ControlModel	-	Direct normal, Direct enhanced, SBO enhanced	-	Direct normal	The control model of the circuit breaker node according to the IEC 61850 standard
Forced Check	-	FALSE, TRUE	-	TRUE	If true, then the check function cannot be neglected by the check attribute defined by the IEC 61850 standard
Max Operating Time	ms	10 – 1000	1	200	When either enhanced control model is selected, the status of the CB must change within this time after the issued command. At timeout an invalid-position error will be generated for the client.
Pulse Duration	ms	50 – 1000	1	300	Duration of the generated On and Off impulse*
Max Intermediate Time	ms	20 – 500	1	100	Waiting time for status signals, at expiry the CB is reported to be in intermediate state
Max SynCheck Time	ms	10 – 5000	1	1000	Length of the time period to wait for the conditions of the synchronous state. After expiry of this time, the synchro-switch procedure is initiated (see synchro-check/ synchro-switch function block description)
Max SynSW Time**	ms	0 – 60000	1	0	Length of the time period to wait for the synchro-switch impulse (see synchro-check/ synchro-switch function block description). After this time the function resets, no switching is performed
SBO Timeout	ms	1000 – 20000	1	5000	Duration of the waiting time between object selection and command selection. At timeout no command is performed

* If the input status signals (stValOff, stValOn) indicate the successful switching then the pulse is withdrawn, but the minimum duration is 100 ms (factory setting).

** If this parameter is set to 0, then the “StartSW” output is not activated

Table 2-1 Parameters of the circuit breaker control function

3.2.2.3.2. Function I/O

This section describes briefly the analogue and digital inputs and outputs of the function block.

3.2.2.3.2.1. Binary input signals (graphed output statuses)

The conditions of the inputs are defined by the user, applying the graphic equation editor (logic editor). The part written in **bold** is seen on the function block in the logic editor.

BINARY INPUT SIGNAL	EXPLANATION
CB1Pol_ Local _GrO_	If this input is active, the circuit breaker can be controlled using the local LCD of the device.
CB1Pol_ Remote _GrO_	If this input is active, the circuit breaker can be controlled via remote communication channels of the SCADA system or the device web page ('commands' menu)
CB1Pol_ SynOK _GrO_	This input indicates if the synchronous state of the voltage vectors at both sides of the circuit breaker enables the closing command. This signal is usually generated by the synchro check/ synchro switch function. If this function is not available, set the input to logic true.
CB1Pol_ EnaOff _GrO_	The active state of this input enables the opening of the circuit breaker. The state is usually generated by the <i>interlocking conditions defined graphically by the user</i> .
CB1Pol_ EnaOn _GrO_	The active state of this input enables the closing of the circuit breaker. The state is usually generated by the <i>interlocking conditions defined graphically by the user</i> .
CB1Pol_ BlkProc _GrO_	The active state of this input blocks the operation of the circuit breaker. The conditions are defined graphically by the user.
CB1Pol_ stValOff _GrO_	Off (Opened) state of the circuit breaker.
CB1Pol_ stValOn _GrO_	On (Closed) state of the circuit breaker.
CB1Pol_ ExtSwitch _GrO_	This signal is considered only when evaluating unintended operation (see "SelfOper" output in Chapter 2.2.2). It indicates that an external command has been issued to the circuit breaker (e.g. trip request from other protection device or external on/off command is given).

Table 2-2 The binary input signals of the circuit breaker control function

3.2.2.3.2.2. Binary output signals (graphed input statuses)

The binary output status signals of the differential protection function. Parts written in **bold** are seen on the function block in the logic editor.

BINARY OUTPUT SIGNAL	SIGNAL TITLE	EXPLANATION
CB1Pol_ CmdOff _Grl_	Off Command	Off command impulse, the duration of which is defined by the parameter "Pulse duration"
CB1Pol_ CmdOn _Grl_	On Command	On command impulse, the duration of which is defined by the parameter "Pulse duration"
CB1Pol_ StartSW _Grl_	Start Synchro-switch	If the synchro check/synchro switch function is applied and the synchronous state conditions are not valid for the time defined by the parameter "Max.SynChk time", then this output triggers the synchro switch function (see synchro-check/synchro-switch function block description).
CB1Pol_ Oper _Grl_	Operation	An impulse with a duration of 150 ms at any operation of the circuit breaker
CB1Pol_ SelfOper _Grl_	Unintended Operation	This output is logic true if the status of the circuit breaker has changed without detected command from the SCADA system or on the input "ExtSwitch"
CB1Pol_ Closed _Grl_	Closed	The filtered status signal for closed state of the circuit breaker
CB1Pol_ Opened _Grl_	Opened	The filtered status signal for opened state of the circuit breaker

Table 2-3 The binary output signals of the circuit breaker control function

3.2.2.3.2.3. On-line data

Visible values on the on-line data page:

SIGNAL TITLE	DIMENSION	EXPLANATION
Status	-	State of the CB (see Chapter 2.2.6)
Off Command	-	Off command impulse, the duration of which is defined by the parameter "Pulse duration"
On Command	-	On command impulse, the duration of which is defined by the parameter "Pulse duration"
Operation	-	An impulse with a duration of 150 ms at any operation of the circuit breaker
Unintended Operation	-	This output is logic TRUE if the status of the circuit breaker has changed without detected command from the SCADA system or on the input "ExtSwitch"
Opened	-	The filtered status signal for opened state of the circuit breaker
Closed	-	The filtered status signal for closed state of the circuit breaker
Operation counter	-	Resettable* counter that increments every time the Operation (see above) output gets active

*The operation counter can be reset on the device web page on-line menu.

Table 2-4 On-line data of the circuit breaker control function

3.2.2.3.2.4. Events

The following events are generated in the event list, as well as sent to SCADA according to the configuration.

EVENT	VALUE	EXPLANATION
Status	Intermediate,Off,On,Bad	CB state indication based on the received signals

Table 2-5 Event of the circuit breaker control function

3.2.2.3.2.5. Commands

The following table contains the issuable commands of the function block. The name of the command channel is used while working in the EuroCAP configuration tool, whereas the title is seen by the user on the device web page.

COMMAND CHANNEL	TITLE	RANGE	EXPLANATION
CB1Pol_Oper_Con_	Operation	Off,On	Issue open (off) or close (on) command on the corresponding outputs of the function block

Table 2-6 The command of the circuit breaker control function

3.2.2.3.2.6. Indication of the four states (Intermediate, On, Off, Bad)

To generate an active scheme on the local LCD, there is an internal status variable indicating the state of the circuit breaker. Different graphic symbols can be assigned to the values, the function block's events are generated also according to this status variable.

This integer status has four values based on the states of the **stValOn** and **stValOff** inputs of the function block.

INTEGER STATUS	TITLE	STVALON STATE	STVALOFF STATE	VALUE	EXPLANATION
CB1Pol_stVal_ISt_	Status	FALSE	FALSE	0: Intermediate	Integer status signal for indicating the state of the CB according to the corresponding inputs of the function block
		FALSE	TRUE	1: Off	
		TRUE	FALSE	2: On	
		TRUE	TRUE	3: Bad	

Table 2-7 State signals from the circuit breaker control function

3.2.2.3.3. Technical data

FUNCTION	VALUE	ACCURACY
Pulse time		< 3 ms

Table 2-8 The technical data of the circuit breaker control function

3.2.2.3.3.1. Notes for testing

If the commands get blocked from time to time during commissioning, it is advised to check how the conditions are fulfilled to issue commands on the function block. The following **three** conditions must be fulfilled at the same time:

- Local or Remote input is active appropriately
- The enabling input (EnaOff or EnaOn) of the issued command (off or on) is active
- (close/on command only) Synchro-check is OK (SynOK input is active)

If there are no conditions to be defined for any of these three (e.g. there is no synchro-check function present, so no valid signal can be provided to that input), the corresponding input can be connected to constant logical TRUE signal provided by the fixture output of the Common function block.

3.2.2.3.3.1.1. IEC 61850 commands

In several configurations the Interlocking and Control logical nodes may have the same prefix for CB and DC function blocks (**INTCILO#** and **SBwCSWI#** respectively where the '#' marks the instance number). This means that their instance number not necessarily corresponds to the actual function block:

- Example: if there are **2** DC and **1** CB function blocks in the same configuration where the former ones were added first, the instance number **#1** and **#2** will belong to the DC function blocks whereas number **#3** will belong to the CB function block even if it is the only CB control function in the device.
- Make sure to check which logical nodes belong to which function by checking the DOI description using the EuroCAP tool (right click the function block in the Logic editor)

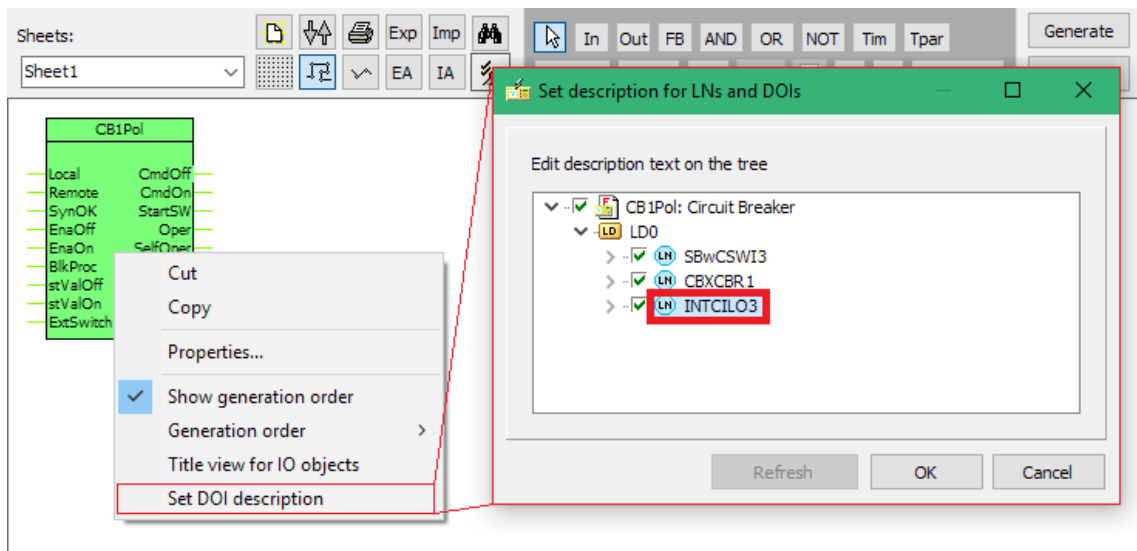

Figure 2-2 Checking the description of the Interlocking LN of the function block

In other cases, the two prefixes are given according to the type of the function block, so they are individual for each (i.e. **CBCILO#** and **CBCSW#** for circuit breaker and **DCCILO#** and **DCCSW#** for disconnector).



3.2.3. Disconnecter control function

3.2.3.1. Application

The disconnector control block can be used to integrate the disconnector control of the EuroProt+ device into the station control system and to apply active scheme screens of the local LCD of the device.

3.2.3.1.1. Mode of operation

The disconnector control block receives remote commands from the SCADA system and local commands from the local LCD of the device, performs the prescribed checking and transmits the commands to the disconnector. It processes the status signals received from the disconnector and offers them to the status display of the local LCD and to the SCADA system.

Main features:

- Local (LCD of the device) and Remote (SCADA) operation modes can be enabled or disabled individually.
- Interlocking functions can be programmed by the user applying the inputs “EnaOff” and “EnaOn”, using the graphic equation editor.
- Programmed conditions can be used to temporarily disable the operation of the function block using the graphic equation editor.
- The function block supports the control models prescribed by the IEC 61850 standard.
- All necessary timing tasks are performed within the function block:
 - Time limitation to execute a command
 - Command pulse duration
 - Filtering the intermediate state of the disconnector
 - Controlling the individual steps of the manual commands
- Sending open and close commands to the disconnector
- Operation counter
- Event reporting

3.2.3.2. Disconnecter control function overview

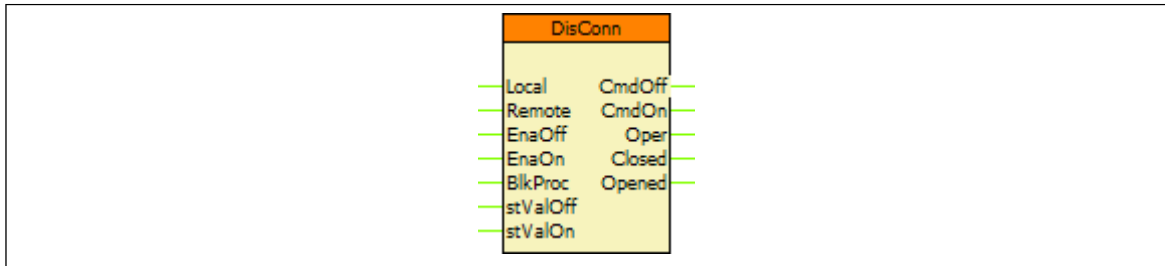

Figure 2-1 Graphic appearance of the function block of the disconnecter control function

3.2.3.2.1. Settings

3.2.3.2.1.1. Parameters

TITLE	DIM	RANGE	STEP	DEFAULT	EXPLANATION
Control Model	-	Direct normal, Direct enhanced, SBO enhanced	-	Direct normal	The control model of the disconnecter node according to the IEC 61850 standard
Type of Switch	-	N/A, Load Break, Disconnecter, Earthing Switch, HS Earthing Switch	-	Disconnecter	
Forced Check	-	FALSE, TRUE	-	TRUE	If true, then the check function cannot be neglected by the check attribute defined by the IEC 61850 standard
Max Operating Time	ms	10 – 60000	1	10000	When either enhanced control model is selected, the status of the DC must change within this time after the issued command. At timeout an invalid-position error will be generated for the client.
Pulse Duration	ms	100 – 60000	1	1000	Duration of the generated On and Off impulse*
Max Intermediate Time	ms	20 – 60000	1	10000	Waiting time for status signals, at expiry the DC is reported to be in intermediate state
SBO Timeout	ms	1000 – 20000	1	5000	Duration of the waiting time between object selection and command selection. At timeout no command is performed

* If the input status signals (stValOff, stValOn) indicate the successful switching then the pulse is withdrawn, but the minimum duration is 1000 ms (factory setting).

Table 2-1 Parameters of the disconnecter control function



3.2.3.2.2. Function I/O

This section describes briefly the analogue and digital inputs and outputs of the function block.

3.2.3.2.2.1. Binary input signals (graphed output statuses)

The conditions of the inputs are defined by the user, applying the graphic equation editor (logic editor). The part written in **bold** is seen on the function block in the logic editor.

BINARY INPUT SIGNAL	EXPLANATION
DisConn_ Local _GrO_	If this input is active, the disconnector can be controlled using the local LCD of the device.
DisConn_ Remote _GrO_	If this input is active, the disconnector can be controlled via remote communication channels of the SCADA system or the device web page ('commands' menu)
DisConn_ EnaOff _GrO_	The active state of this input enables the opening of the disconnector. The state is usually generated by the <i>interlocking conditions defined graphically by the user</i> .
DisConn_ EnaOn _GrO_	The active state of this input enables the closing of the disconnector. The state is usually generated by the <i>interlocking conditions defined graphically by the user</i> .
DisConn_ BlkProc _GrO_	The active state of this input blocks the operation of the disconnector. The conditions are defined graphically by the user.
DisConn_ stValOff _GrO_	Off (Opened) state of the disconnector.
DisConn_ stValOn _GrO_	On (Closed) state of the disconnector.

Table 2-2 The binary input signals of the disconnector control function

3.2.3.2.2.2. Binary output signals (graphed input statuses)

The binary output status signals of the differential protection function. Parts written in **bold** are seen on the function block in the logic editor.

BINARY OUTPUT SIGNAL	SIGNAL TITLE	EXPLANATION
DisConn_ CmdOff _Grl_	Off Command	Off command impulse, the duration of which is defined by the parameter "Pulse duration"
DisConn_ CmdOn _Grl_	On Command	On command impulse, the duration of which is defined by the parameter "Pulse duration"
DisConn_ Oper _Grl_	Operation	An impulse with a duration of 150 ms at any operation of the disconnector
DisConn_ Closed _Grl_	Closed	The filtered status signal for closed state of the disconnector
DisConn_ Opened _Grl_	Opened	The filtered status signal for opened state of the disconnector

Table 2-3 The binary output signals of the disconnector control function



3.2.3.2.2.3. On-line data

Visible values on the on-line data page:

SIGNAL TITLE	DIMENSION	EXPLANATION
Status	-	State of the DC (see Chapter 2.2.6)
Off Command	-	Off command impulse, the duration of which is defined by the parameter "Pulse duration"
On Command	-	On command impulse, the duration of which is defined by the parameter "Pulse duration"
Operation	-	An impulse with a duration of 150 ms at any operation of the disconnecter
Opened	-	The filtered status signal for opened state of the disconnecter
Closed	-	The filtered status signal for closed state of the disconnecter
Operation counter	-	Resettable* counter that increments every time the Operation (see above) output gets active

Table 2-4 On-line data of the disconnecter control function

*The operation counter can be reset on the device web page on-line menu.

3.2.3.2.2.4. Events

The following events are generated in the event list, as well as sent to SCADA according to the configuration.

EVENT	VALUE	EXPLANATION
Status	Intermediate,Off,On,Bad	DC state indication based on the received status signals

Table 2-5 Event of the disconnecter control function

3.2.3.2.2.5. Commands

The following table contains the issuable commands of the function block. The name of the command channel is used while working in the EuroCAP configuration tool, whereas the title is seen by the user on the device web page.

COMMAND CHANNEL	TITLE	RANGE	EXPLANATION
DisConn_Oper_Con_	Operation	Off,On	Issue open (off) or close (on) command on the corresponding outputs of the function block

Table 2-6 The command of the disconnecter control function

3.2.3.2.2.6. Indication of the four states (Intermediate, On, Off, Bad)

To generate an active scheme on the local LCD, there is an internal status variable indicating the state of the disconnecter. Different graphic symbols can be assigned to the values, the function block's events are generated also according to this status variable.

This integer status has four values based on the states of the **stValOn** and **stValOff** inputs of the function block.

INTEGER STATUS	TITLE	STVALON STATE	STVALOFF STATE	VALUE	EXPLANATION
DisConn_stVal_ISt_	Status	FALSE	FALSE	0: Intermediate	Integer status signal for indicating the state of the DC according to the corresponding inputs of the function block
		FALSE	TRUE	1: Off	
		TRUE	FALSE	2: On	
		TRUE	TRUE	3: Bad	

Table 2-7 State signals from the disconnecter control function

3.2.3.2.3. Technical data

FUNCTION	VALUE	ACCURACY
Operate time		±5% or ±15 ms, whichever is greater

Table 2-8 The technical data of the disconnecter control function

3.2.3.2.3.1. Notes for testing

If the commands get blocked from time to time during commissioning, it is advised to check how the conditions are fulfilled to issue commands on the function block. The following **three** conditions must be fulfilled at the same time:

- Local or Remote input is active appropriately
- The enabling input (EnaOff or EnaOn) of the issued command (off or on) is active

If there are no conditions to be defined for any of these two (e.g. there is no difference made between local/remote control), the corresponding input can be connected to constant logical TRUE signal provided by the fixture output of the Common function block.

3.2.3.2.3.1.1. IEC 61850 commands

In several configurations the Interlocking and Control logical nodes may have the same prefix for DC and CB function blocks (**INTCILO#** and **SBwCSWI#** respectively where the '#' marks the instance number). This means that their instance number not necessarily corresponds to the actual function block:

- Example: if there are **1** CB and **1** DC function blocks in the same configuration where the former was added first, the instance number **#1** will belong to the CB function block whereas number **#2** will belong to the DC function block even if it is the only DC control function in the device.
- Make sure to check which logical nodes belong to which function by checking the DOI description using the EuroCAP tool (right click the function block in the Logic editor)

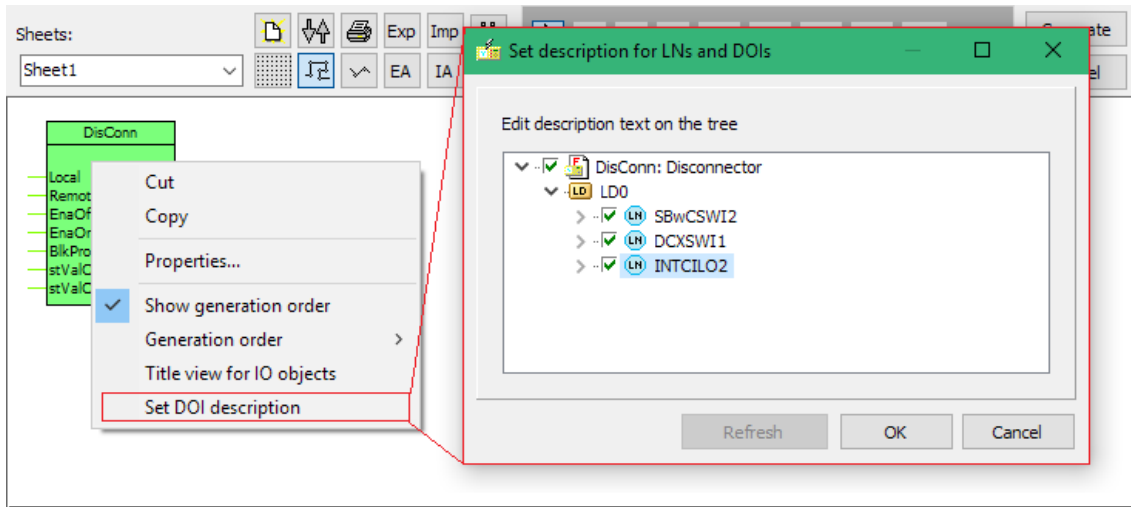

Figure 2-2 Checking the description of the Interlocking LN of the function block

In other cases, the two prefixes are given according to the type of the function block, so they are individual for each (i.e. **DCCILO#** and **DCCSW#** for disconnector and **CBCILO#** and **CBCSW#** for circuit breaker).

3.2.3.3. Example logic

A simple example can be seen below of how to insert the function block in the user logic using the EuroCAP Logic Editor:

- The Local/Remote state of the device is provided by the Common function block which is present in all configurations
- The connections to the BIn and BOut elements show the connections to the physical input and output contacts
- The highlighted signal leading to the EnaOff and EnaOn inputs is the realization of the interlocking logic. In this case the disconnecter can operate only if the circuit breaker is opened.

The opened state of the CB is now indicated by its filtered 'Opened' signal which is active only if the CB is open and there is no state error (or intermediate state) of it.

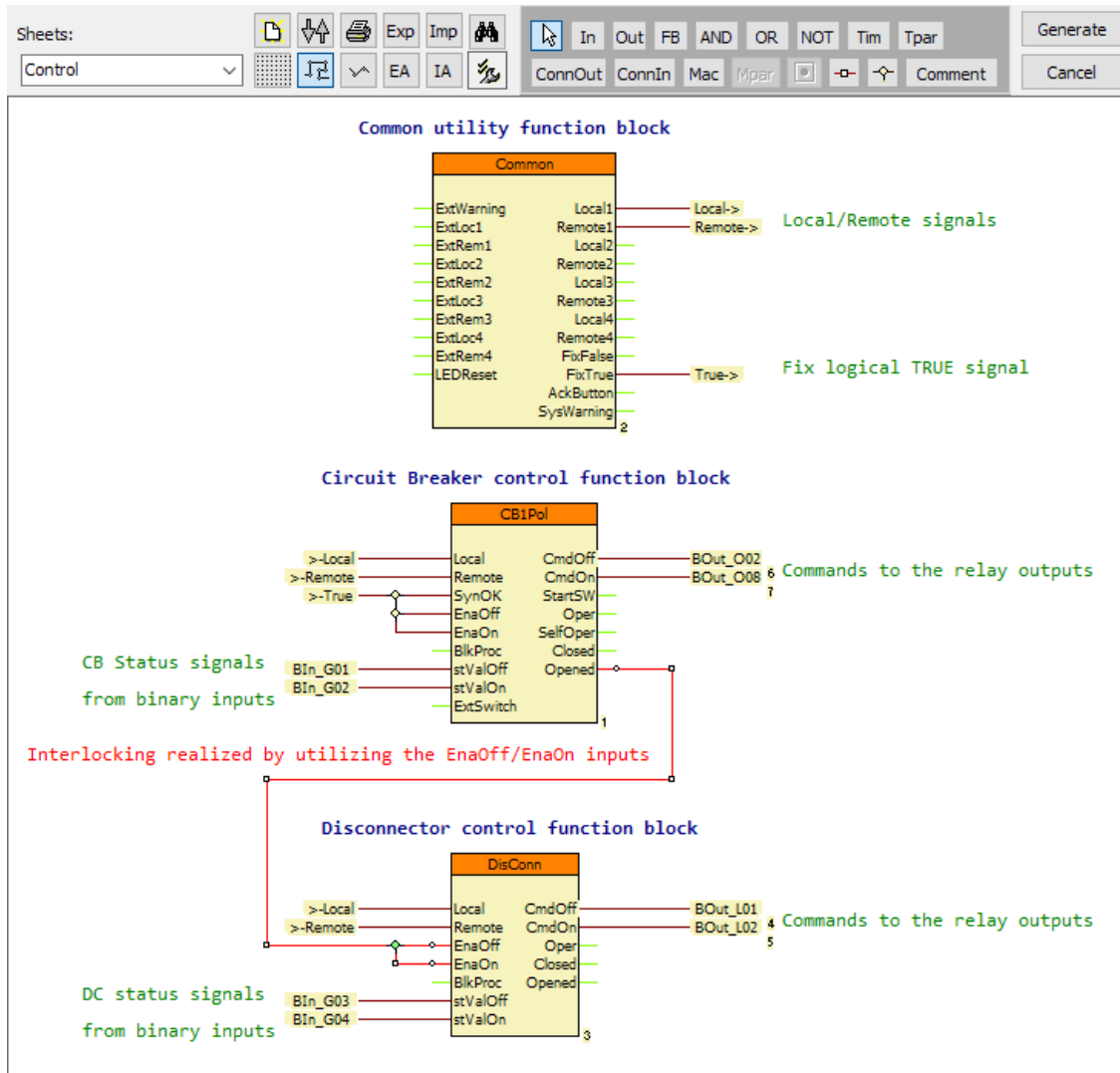
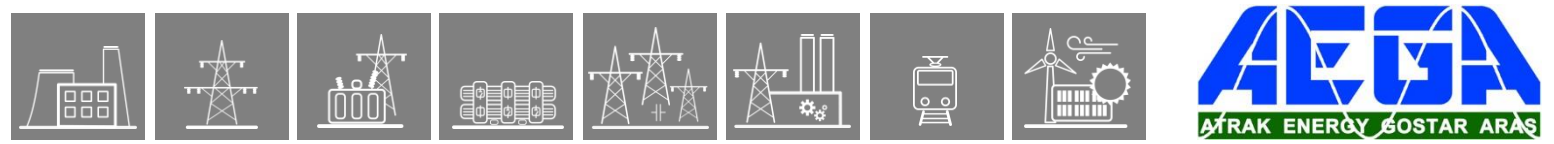

Figure 3-1 Inserting the disconnector function block into the logic (example)



3.2.4. Ethernet Links function

3.2.4.1. Introduction

The EuroProt+ device constantly checks the statuses of its connections to the outside world (wherever possible). These statuses can be seen on the **status/log** page in the advanced menu on the web page of the device.

When further indications are needed or the signals of the statuses (such as events, logic signals for the user logic, LEDs etc.), the Ethernet Links function block makes these available for the user.

3.2.4.1.1. Ports

The function can check the following types of communication ports:

- Fiber Optic (MM – multi mode)
- Fiber Optic (SM – single mode)
- RJ45
- PRP/HSR
- EOB (Ethernet On Board on the front HMI of the device)

See the EuroProt+ Hardware Description (different document) for the list of the CPU modules that contain any of these ports.

3.2.4.2. Ethernet Links function overview

The graphic appearance of the function block is shown on [Figure 2-1](#). These blocks show all binary input and output status signals, which are applicable in the graphic equation editor.

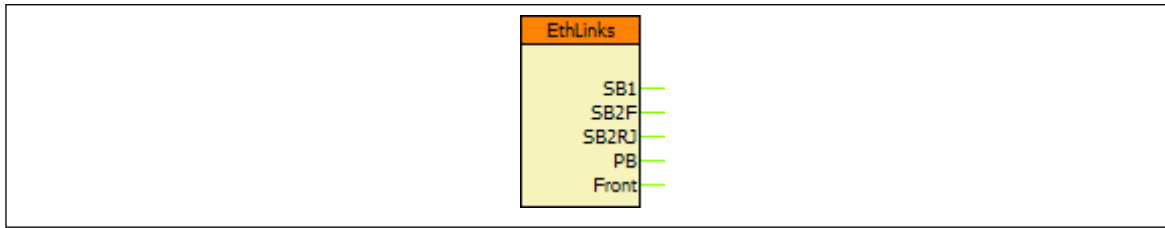

Figure 2-1 Graphic appearance of the function block of the ethernet links function

3.2.4.2.1. Settings

There are no settings for this function block.

3.2.4.2.2. Function I/O

This section describes briefly the analogue and digital inputs and outputs of the function block. This function block owns only binary output signals.

3.2.4.2.2.1. Binary output signals (graphed input statuses)

The binary output status signals of the Ethernet Links function. **Parts written in bold** are seen on the function block in the logic editor.

BINARY OUTPUT SIGNAL	SIGNAL TITLE	EXPLANATION
EthLnk_ SB1 _Grl_	Station Bus1	Active if the first (upper) fiber optic port of the CPU module has an active connection.
EthLnk_ SB2F _Grl_	Station Bus2 – Fiber	Active if the second (middle) fiber optic port of the CPU module has an active connection.
EthLnk_ SB2RJ _Grl_	Station Bus2 –RJ4	Active if the RJ45 port of the CPU module has an active connection.
EthLnk_ PB _Grl_	Process Bus	Active if the third (lower) fiber optic port of the CPU module has an active connection
EthLnk_ Front _Grl_	RJ45/EOB on front panel	Active if the front RJ45 port (or EOB) has an active connection

Table 2-1 The binary output status signals of the ethernet links function

3.2.4.2.2.2. On-line data

Visible values on the on-line data page:

SIGNAL TITLE	DIMENSION	EXPLANATION
Station Bus1	-	Active if the first (upper) fiber optic port of the CPU module has an active connection.
Station Bus2 – Fiber	-	Active if the second (middle) fiber optic port of the CPU module has an active connection.
Station Bus2 –RJ4	-	Active if the RJ45 port of the CPU module has an active connection.
Process Bus	-	Active if the third (lower) fiber optic port of the CPU module has an active connection
RJ45/EOB on front panel	-	Active if the front RJ45 port (or EOB) has an active connection

Table 2-2 The measured analogue values of the ethernet links function



3.2.4.2.2.3. Events

The following events are generated in the event list, as well as sent to SCADA according to the configuration.

EVENT	VALUE	EXPLANATION
Station Bus1	off, on	Active if the first (upper) fiber optic port of the CPU module has an active connection.
Station Bus2 – Fiber	off, on	Active if the second (middle) fiber optic port of the CPU module has an active connection.
Station Bus2 –RJ4	off, on	Active if the RJ45 port of the CPU module has an active connection.
Process Bus	off, on	Active if the third (lower) fiber optic port of the CPU module has an active connection
RJ45/EOB on front panel	off, on	Active if the front RJ45 port (or EOB) has an active connection

Table 2-3 Events of the ethernet links function

3.2.4.2.3. Technical data

There is no technical data to add.

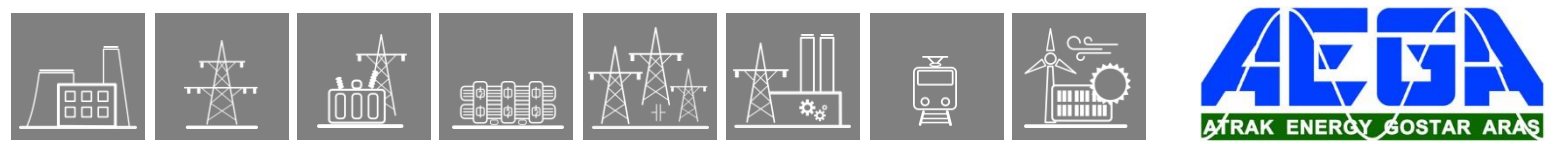

3.2.5. Voltage transformer supervision function

The voltage transformer supervision function generates a signal to indicate an error in the voltage transformer secondary circuit. This signal can serve, for example, as a warning, indicating disturbances in the measurement, or it can disable the operation of the distance protection function if appropriate measured voltage signals are not available for a distance decision.

The voltage transformer supervision function is designed to detect faulty asymmetrical states of the voltage transformer circuit caused, for example, by a broken conductor in the secondary circuit.

(Another method for detecting voltage disturbances is the supervision of the auxiliary contacts of the miniature circuit breakers in the voltage transformer secondary circuits. This function is not described here.)

The user has to generate graphic equations for the application of the signal of this voltage transformer supervision function.

This function is interconnected with the “dead line detection function”. Although the dead line detection function is described fully in a separate document, the explanation necessary to understand the operation of the VT supervision function is repeated also in this document.

3.2.5.1. Mode of operation

3.2.5.1.1. “Dead line detection” (DLD) function - modes of operation

The voltage transformer supervision function is based on the “Dead line detection” (DLD) function, the task of which is to decide the Dead line/Live line state.

Criteria of “Dead line” state: all three phase voltages are below the preset voltage value AND all three currents are below the preset current value.

Criteria of “Live line” state: all three phase voltages are above the preset voltage value.

The dead line detection function is described in a separate document.

3.2.5.1.2. “Voltage transformer supervision” (VTS) function - modes of operation

The voltage transformer supervision function can be used in three different modes of application:

Zero sequence detection (for typical applications in systems with grounded neutral): “VT failure” signal is generated if the residual voltage ($3U_0$) is above the preset voltage value AND the residual current ($3I_0$) is below the preset current value.

Negative sequence detection (for typical applications in systems with isolated or resonant grounded (Petersen) neutral): “VT failure” signal is generated if the negative sequence voltage component (U_2) is above the preset voltage value AND the negative sequence current component (I_2) is below the preset current value.

Special application: “VT failure” signal is generated if the residual voltage ($3U_0$) is above the preset voltage value AND the residual current ($3I_0$) AND the negative sequence current component (I_2) are below the preset current values.



3.2.5.1.3. Activating the VTS function

The voltage transformer supervision function can be activated if “Live line” status is detected for at least 200 ms. This delay avoids mal-operation at line energizing if the poles of the circuit breaker make contact with a time delay. The function is set to be inactive if “Dead line” status is detected.

If the conditions specified by the selected mode of operation are fulfilled (for at least 4 milliseconds) then the voltage transformer supervision function is activated and the operation signal is generated. (When evaluating this time delay, the natural operating time of the applied Fourier algorithm must also be considered.)

NOTE: For the operation of the voltage transformer supervision function the “Dead line detection function” must be operable as well: it must be enabled by binary parameter setting, and its blocking signal may not be active.

3.2.5.1.4. Resetting the VTS function

If, in the active state, the conditions for operation are no longer fulfilled, the resetting of the function depends on the mode of operation of the primary circuit:

- If the “Live line” state is valid, then the function resets after approx. 200 ms of time delay. (When evaluating this time delay, the natural operating time of the applied Fourier algorithm must also be considered.)
- If the “Dead line” state is started and the “VTS Failure” signal has been continuous for at least 100 ms, then the “VTS failure” signal does not reset; it is generated continuously even when the line is in a disconnected state. Thus, the “VTS Failure” signal remains active at reclosing.
- If the “Dead line” state is started and the “VTS Failure” signal has not been continuous for at least 100 ms, then the “VTS failure” signal resets.

3.2.5.2. Structure of the voltage transformer supervision algorithm

Fig.1-1 shows the structure of the voltage transformer supervision (VTS) algorithm.

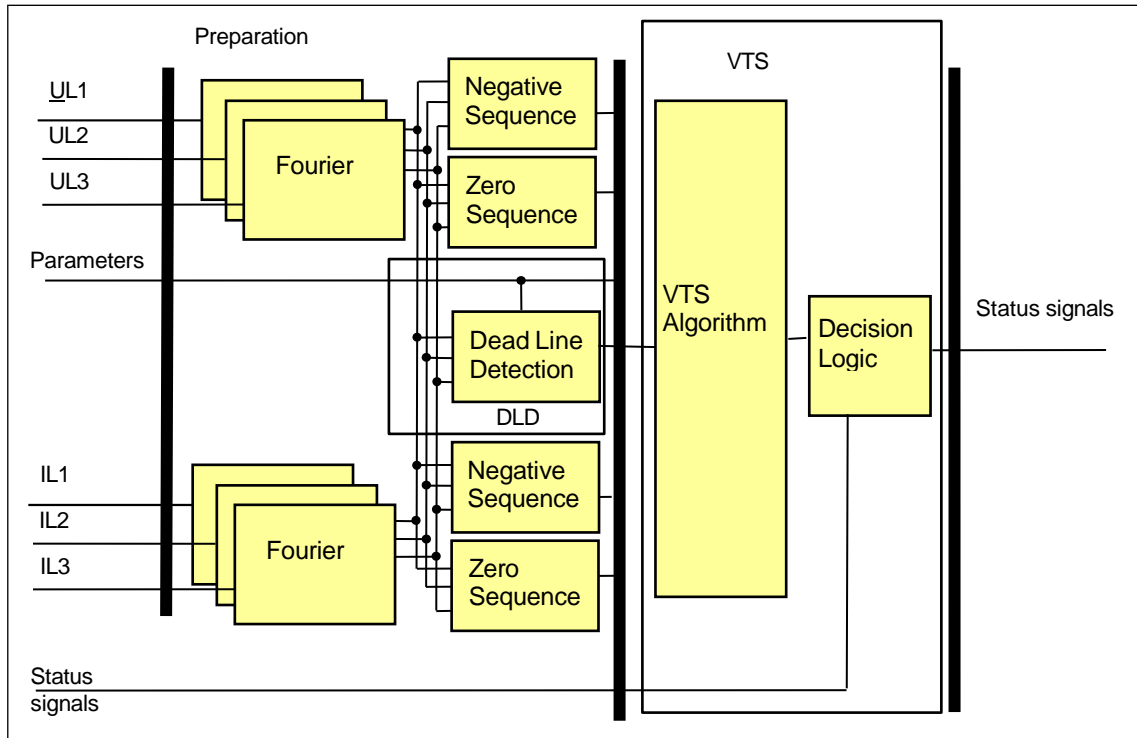

Figure 1-1 Structure of the voltage transformer supervision algorithm

For the preparation phase:

The **inputs** are

- the sampled values of the three phase voltages (UL1, UL2, UL3) and three phase currents (IL1, IL2, IL3),
- parameters.

The **outputs** are

- negative and zero sequence voltage and current components.
- signals indicating the “Live line” or “Dead line” condition.

For the VTS function:

The **inputs** are

- negative and zero sequence voltage and current components.
- signals indicating the “Live line” or “Dead line” condition,
- parameters,
- status signals.

The **outputs** are

- the binary output status signal indicating a failure of the voltage transformer secondary circuit,
- signals indicating the “Live line” or “Dead line” condition.



The **software modules** of the voltage transformer supervision function and those of the preparation phase:

Fourier calculations

These modules calculate the basic Fourier current components of the phase voltages and currents. These modules belong to the preparation phase.

Negative sequence

This module calculates the basic Fourier current components of the negative sequence voltage and current, based on the Fourier components of the phase voltages and currents. This module belongs to the preparation phase.

Zero sequence

This module calculates the basic Fourier voltage and current components of the residual voltage ($3U_0$) and current ($3I_0$), based on the Fourier components of the phase voltages and currents. This module belongs to the preparation phase.

Dead Line Detection

This module decides if the "Line_OK condition" or the "DeadLine condition" is fulfilled. This module belongs to the preparation phase.

VTS algorithm

This module decides if the "VTS_FAIL" conditions are fulfilled according to the conditions specified for the selected mode.

Decision logic

The decision logic module combines the status signals to generate the trip command of the function.

The following description explains the details of the individual components.

3.2.5.3. The Fourier calculation (Fourier)

These modules calculate the basic Fourier current components of the phase voltages and phase currents individually. These modules belong to the preparation phase.

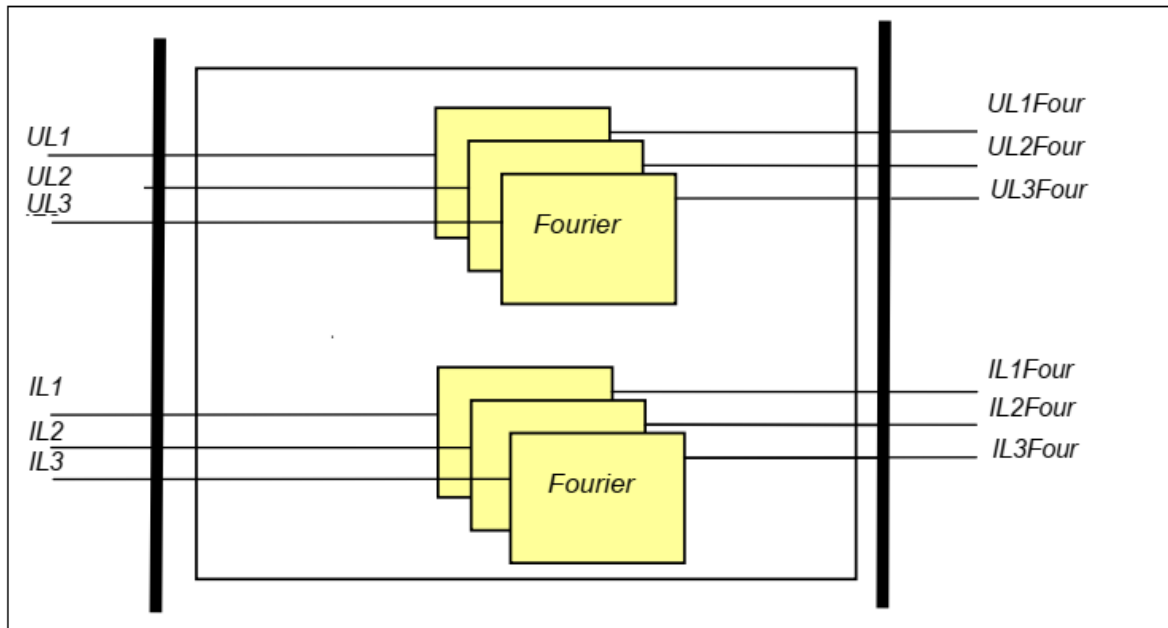

Figure 1-2 Principal scheme of the Fourier calculation

The **inputs** are the sampled values of:

- the three phase voltages (UL1, UL2, UL3)
- the three phase currents (IL1, IL2, IL3)

The **outputs** are

- the basic Fourier components of the analyzed voltages (UL1Four, UL2Four, UL3Four),
- the basic Fourier components of the analyzed currents (IL1Four, IL2Four, IL3Four).

3.2.5.4. The negative phase sequenc calculation (Negative sequence)

This module calculates the negative phase sequence components based on the Fourier components of the phase voltages and phase currents. These modules belong to the preparation phase.

The **inputs** are the basic Fourier components of the phase voltages and phase currents (UL1Four, UL2Four, UL3Four, IL1Four, IL2Four, IL3Four).

The **outputs** are

- the basic Fourier components of the negative sequence voltage component (UNegFour),
- the basic Fourier components of the negative sequence current component (INegFour).

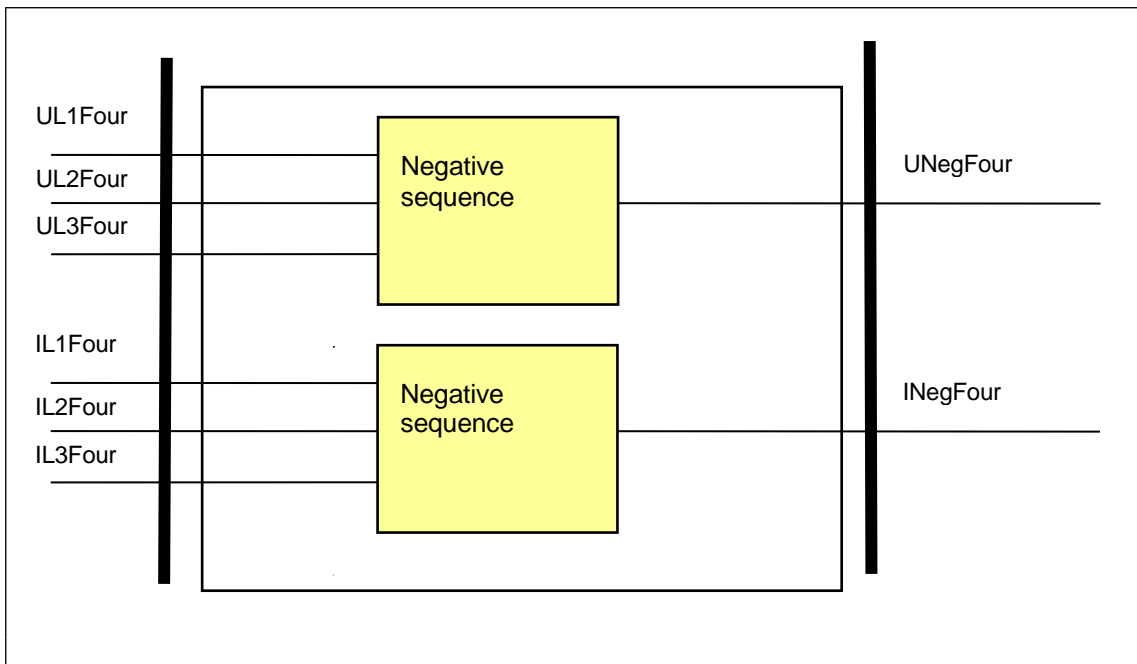

Figure 1-3 Schema of the negative sequence component calculation

3.2.5.5. The residual voltage and current calculation (Zero sequence)

This module calculates the residual voltage ($U_{ZerFour}$) and current ($I_{ZerFour}$) based on the Fourier components of the phase voltages and currents. These modules belong to the preparation phase.

The **inputs** are

- the basic Fourier components of the phase voltages ($UL1Four$, $UL2Four$, $UL3Four$),
- the basic Fourier components of the phase currents ($IL1Four$, $IL2Four$, $IL3Four$).

The **outputs** are

- the basic Fourier components of the residual voltage ($U_{ZerFour}$),
- the basic Fourier components of the residual current ($I_{ZerFour}$).

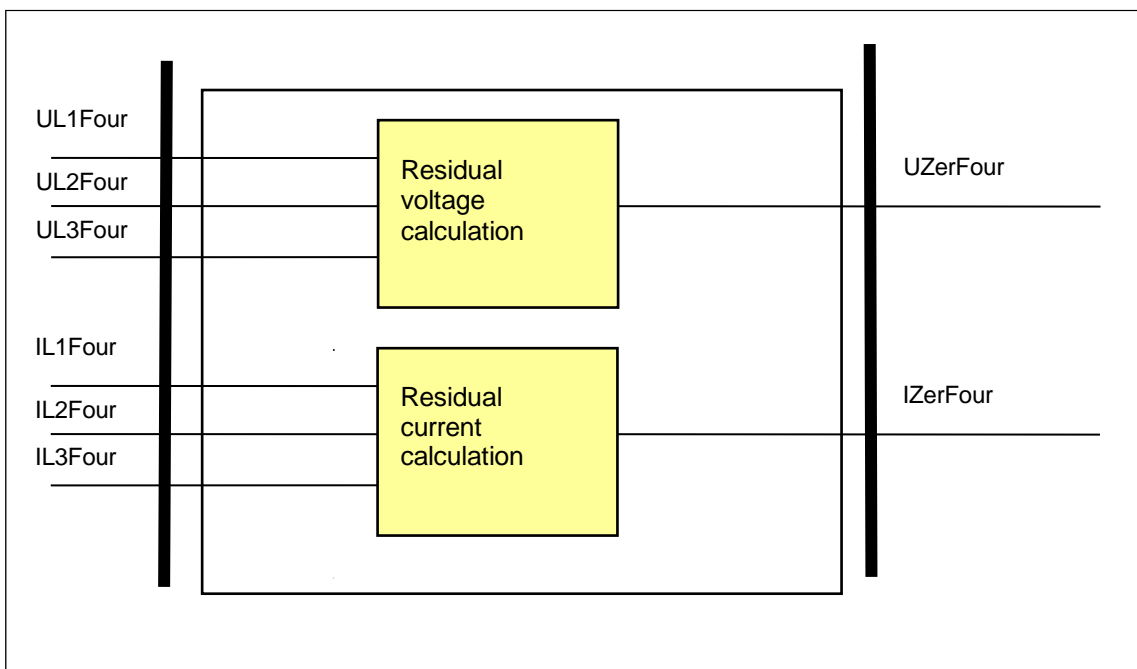

Figure 1-4 Schema of the residual voltage and current calculation

3.2.5.6. The dead line detection algorithm (Dead Line Detection)

This module decides if the “Line_OK condition” or the “DeadLine condition” is fulfilled. This module belongs to the preparation phase.

The **inputs** are

- the basic Fourier components of the phase voltages (UL1Four, UL2Four, UL3Four),
- the basic Fourier components of the phase currents (IL1Four, IL2Four, IL3Four),
- parameters.

The **outputs** are the internal status signals of the function. These indicate the “DeadLine condition state” or the “Line_OK conditions” state. This module belongs to the preparation phase.

Criteria of “Dead line” state: all three phase voltages are below the voltage setting value AND all three currents are below the current setting value.

Criteria of “Live line” state: all three phase voltages are above the voltage setting value.

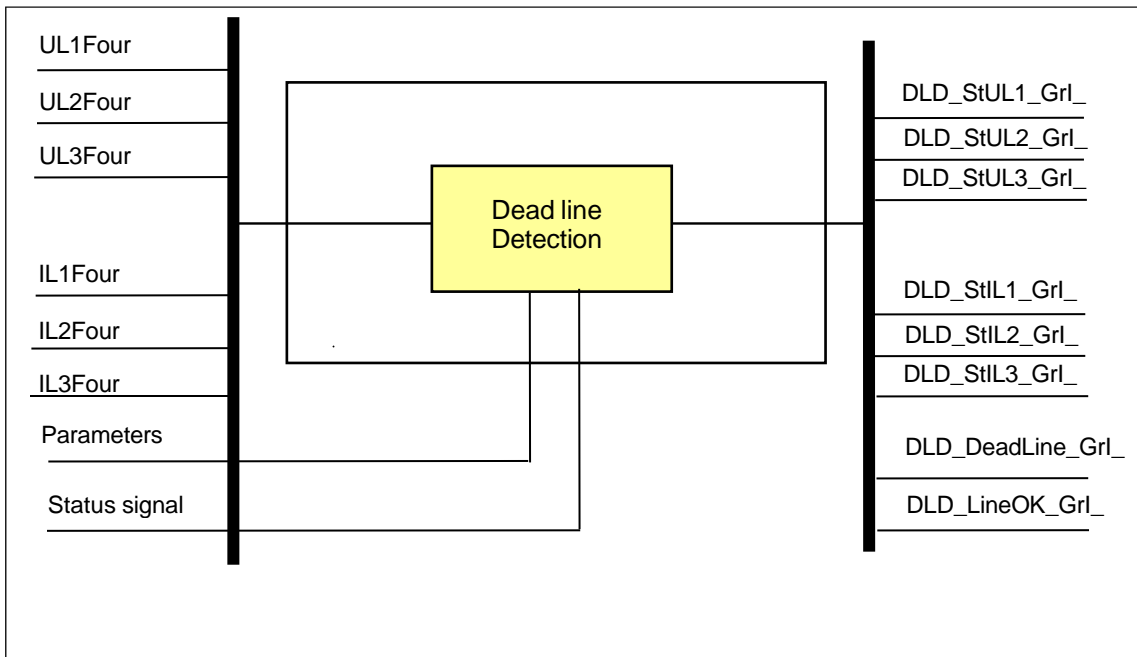

Figure 1-5 Principal scheme of the dead line detection function

The parameters of the dead line detection function are listed in [Table 1-1](#).

Integer parameters

Parameter name	Title	Unit	Min	Max	Step	Default
Integer parameters of the dead line detection function						
DLD_ULev_IPar_	Min Operate Voltage	%	10	100	1	60
DLD_ILev_IPar_	Min Operate Current	%	2	100	1	10

Table 1-1 The integer parameters of the dead line detection function

Binary status signals

The dead line detection function has a binary input signal, which serves the purpose of disabling the function. **The conditions of disabling are defined by the user, applying the graphic equation editor.**

Binary status signal	Explanation
DLD_Blk_GrO_	Output status of a graphic equation defined by the user to disable the dead line detection function.

Table 1-2 The binary input signal of the dead line detection function

The **binary output status signals** of the dead line detection function are listed in [Table 1-3](#).

Binary output signals	Signal title	Explanation
DLD_StUL1_GrI_	Start UL1	The voltage of phase L1 is above the preset parameter value
DLD_StUL2_GrI_	Start UL2	The voltage of phase L2 is above the preset parameter value
DLD_StUL3_GrI_	Start UL3	The voltage of phase L3 is above the preset parameter value
DLD_StIL1_GrI_	Start IL1	The current of phase L1 is above the preset parameter value
DLD_StIL2_GrI_	Start IL2	The current of phase L2 is above the preset parameter value
DLD_StIL3_GrI_	Start IL3	The current of phase L3 is above the preset parameter value
DLD_DeadLine_GrI_	DeadLine condition	The criteria for dead line condition are fulfilled
DLD_LineOK_GrI_	LineOK condition	The criteria for line OK condition are fulfilled

Table 1-3 The binary output status signals of the dead line detection function



3.2.5.7. Voltage transformer supervision (VTS algorithm)

The voltage transformer supervision function can be used in three different modes of operation:

Zero sequence detection (for typical applications in systems with grounded neutral): “VT failure” signal is generated if the residual voltage ($3U_0$) is above the preset voltage value AND the residual current ($3I_0$) is below the preset current value.

Negative sequence detection (for typical applications in systems with isolated or resonant grounded (Petersen) neutral): “VT failure” signal is generated if the negative sequence voltage component (U_2) is above the preset voltage value AND the negative sequence current component (I_2) is below the preset current value.

Special application: “VT failure” signal is generated if the residual voltage ($3U_0$) is above the preset voltage value AND the residual current ($3I_0$) AND the negative sequence current component (I_2) are below the preset current values.

The task of this module is to detect if the conditions of the “VTS FAIL” state are fulfilled, according to the conditions defined for the selected mode of operation.

The **inputs** are

- the basic Fourier components of the residual voltage ($UZerFour$) and current ($IZerFour$),
- the negative sequence components of the voltage ($UNegFour$) and current ($INegFour$),
- binary signals from the dead line detection function,
- parameters.

NOTE: For the operation of the voltage transformer supervision function the “Dead line detection function” must be operable as well: it must be enabled by binary parameter setting, and its blocking signal may not be active.

The **output** is the internal status signal of the function. This internal signal indicates if the “VTS_FAIL_int” condition is fulfilled.

Binary output signals	Signal title	Explanation
VTS_FAIL_int	VTS_FAIL_int	Internal status signal indicating the fulfillment of conditions. This status signal is not available for the users.

Table 1-4 The binary internal status signals of the voltage transformer supervision algorithm

The parameters of the voltage transformer supervision algorithm are listed in [Table 1-5](#) and in [Table 1-6](#).



Enumerated parameter

Parameter name	Title	Selection range	Default
Parameter for type selection			
VTS_Oper_EPar_	Operation	Off, Zero sequence, Neg sequence, Special	Zero sequence

Table 1-5 The enumerated parameters of the voltage transformer supervision function

Integer parameters

Parameter name	Title	Unit	Min	Max	Step	Default
Starting voltage and current parameter for residual and negative sequence detection:						
VTS_Uo_IPar_	Start URes	%	5	50	1	30
VTS_Io_IPar_	Start IRes	%	10	50	1	10
VTS_Uneg_IPar_	Start UNeg	%	5	50	1	10
VTS_Ineg_IPar_	Start INeg	%	10	50	1	10

Table 1-6 The integer parameters of the voltage transformer supervision algorithm

3.2.5.8. The decision logic (Decision logic)

The decision logic module combines the status signals, binary and enumerated parameters to generate the trip command of the function.

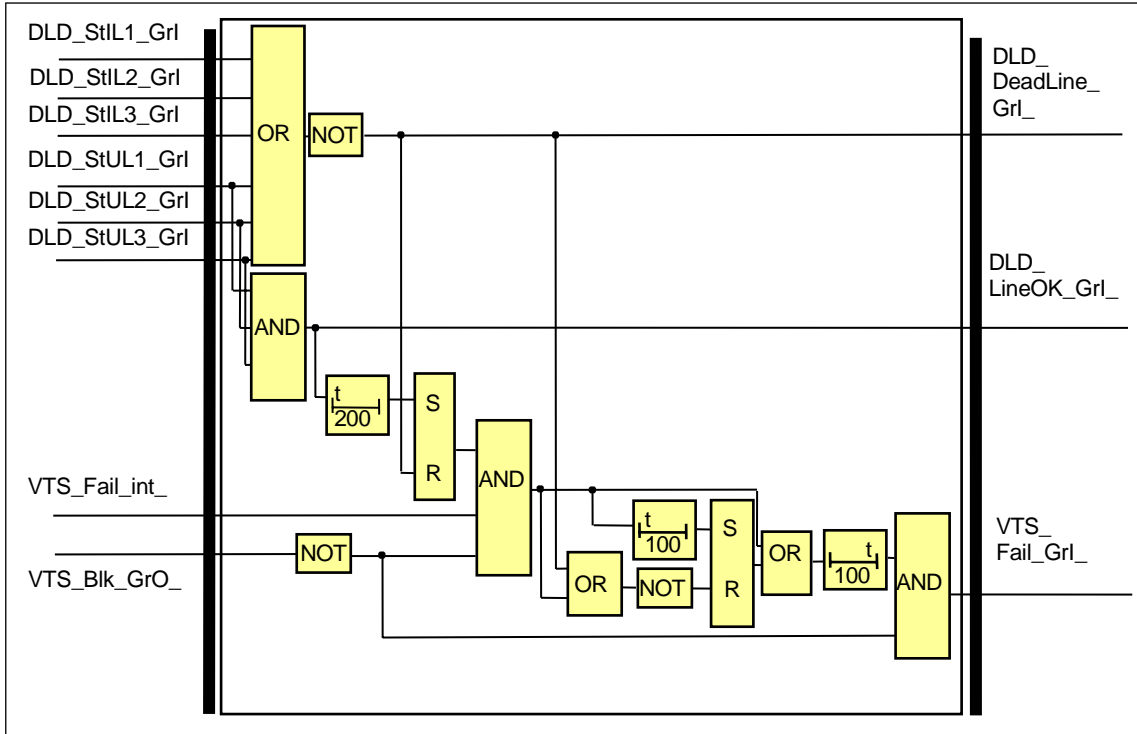
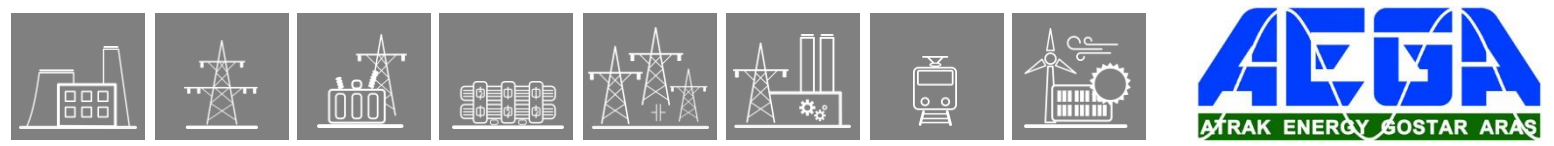

Figure 1-6 The logic scheme of the decision logic

Binary input signals	Signal title	Explanation
DLD_StUL1_Grl_	Start UL1	The voltage of phase L1 is above the preset parameter value
DLD_StUL2_Grl_	Start UL2	The voltage of phase L2 is above the preset parameter value
DLD_StUL3_Grl_	Start UL3	The voltage of phase L3 is above the preset parameter value
DLD_StIL1_Grl_	Start IL1	The current of phase L1 is above the preset parameter value
DLD_StIL2_Grl_	Start IL2	The current of phase L2 is above the preset parameter value
DLD_StIL3_Grl_	Start IL3	The current of phase L3 is above the preset parameter value
VTS_FAIL_int	VTS_FAIL_int	Internal status signal indicating the fulfillment of conditions. This status signal is not available for the users.

Table 1-7 The binary input signals of the decision logic



Binary status signals

The voltage transformer supervision function has a binary input signal, which serves the purpose of disabling the function. **The conditions of disabling are defined by the user, applying the graphic equation editor.**

Binary status signal	Explanation
VTS_BlK_GrO_	Output status of a graphic equation defined by the user to disable the voltage transformer supervision function.

Table 1-8 The binary input signal of the decision logic

Binary output signals	Signal title	Explanation
DLD_DeadLine_Grl_	DeadLine condition	The requirements of “DeadLine condition” are fulfilled
DLD_LineOK_Grl_	LineOK condition	The requirements of “LineOK condition” are fulfilled
VTS_Fail_Grl	VT Failure	Failure status signal of the VTS function

Table 1-9 The binary output status signals of the decision logic

3.2.5.9. Technical summary

3.2.5.9.1. Technical data

Function	Value	Accuracy
Pick-up voltage I ₀ =0A I ₂ =0A		<1% <1%
Operation time	<20ms	
Reset ratio	0.95	

Table 1-10 Technical data of the voltage transformer supervision function

3.2.5.9.2. The parameters

Integer parameters

Parameter name	Title	Unit	Min	Max	Step	Default
Integer parameters of the dead line detection function						
DLD_ULev_IPar_	Min Operate Voltage	%	10	100	1	60
DLD_ILev_IPar_	Min Operate Current	%	2	100	1	10
Starting voltage and current parameter for residual and negative sequence detection:						
VTS_Uo_IPar_	Start URes	%	5	50	1	30
VTS_Io_IPar_	Start IRes	%	10	50	1	10
VTS_Uneg_IPar_	Start UNeg	%	5	50	1	10
VTS_Ineg_IPar_	Start INeg	%	10	50	1	10

Table 1-11 The integer parameters of the voltage transformer supervision function

Enumerated parameter

Parameter name	Title	Selection range	Default
Parameter for type selection			
VTS_Oper_EPar_	Operation	Off, Zero sequence, Neg. sequence, Special	Zero sequence

Table 1-12 The enumerated parameter of the voltage transformer supervision function



3.2.5.9.3. The binary input status signals

Binary status signals

The voltage transformer supervision function has a binary input signal, which serves the purpose of disabling the function. **The conditions of disabling are defined by the user, applying the graphic equation editor.**

Binary status signal	Explanation
VTS_BlK_GrO_	Output status of a graphic equation defined by the user to disable the voltage transformer supervision function.

Table 1-13 The binary input signal of the voltage transformer supervision function

3.2.5.9.4. Binary output status signals

The **binary output status signals** of the voltage transformer supervision function are listed in Table 1-14.

Binary output signals	Signal title	Explanation
DLD function		
DLD_StUL1_Grl_	Start UL1	The voltage of phase L1 is above the preset parameter value, signal of the DLD function
DLD_StUL2_Grl_	Start UL2	The voltage of phase L2 is above the preset parameter value, signal of the DLD function
DLD_StUL3_Grl_	Start UL3	The voltage of phase L3 is above the preset parameter value, signal of the DLD function
DLD_StIL1_Grl_	Start IL1	The current of phase L1 is above the preset parameter value, signal of the DLD function
DLD_StIL2_Grl_	Start IL2	The current of phase L2 is above the preset parameter value, signal of the DLD function
DLD_StIL3_Grl_	Start IL3	The current of phase L3 is above the preset parameter value, signal of the DLD function
DLD_DeadLine_Grl_	DeadLine condition	The requirements of "DeadLine condition" are fulfilled, signal of the DLD function
DLD_LineOK_Grl_	LineOK condition	The requirements of "LineOK condition" are fulfilled, signal of the DLD function
VTS function		
VTS_Fail_Grl	VT Failure	Failure status signal of the VTS function

Table 1-14 The binary output signals of the voltage transformer supervision function

3.2.5.9.5. The function block

The function block of the dead line detection and voltage transformer supervision function is shown in [Figure 1-7](#). This block shows all binary input and output status signals that are applicable in the graphic equation editor.

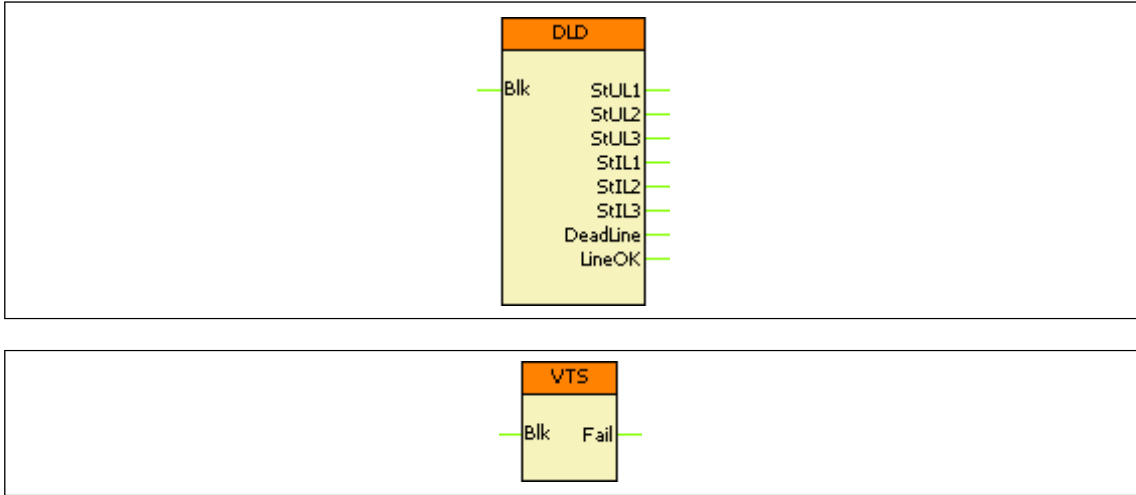

Figure 1-7 The function block of the dead line detection and voltage transformer supervision function

<i>Synchrocheck function (SYN25)</i>	
Voltage Diff	Voltage different value
Frequency Diff	Frequency different value
Angle Diff	Angle different value
<i>Line measurement (MXU_L) (here the displayed information means primary value)</i>	
Active Power – P	Three-phase active power
Reactive Power – Q	Three-phase reactive power
Apparent Power – S	Three-phase power based on true RMS voltage and current measurement
Current L1	True RMS value of the current in phase L1
Current L2	True RMS value of the current in phase L2
Current L3	True RMS value of the current in phase L3
Voltage L1	True RMS value of the voltage in phase L1
Voltage L2	True RMS value of the voltage in phase L2
Voltage L3	True RMS value of the voltage in phase L3
Voltage L12	True RMS value of the voltage between phases L1 L2
Voltage L23	True RMS value of the voltage between phases L2 L3
Voltage L31	True RMS value of the voltage between phases L3 L1
Frequency	Frequency
<i>Metering (MTR)</i>	
Forward MWh	Forward MWh
Backward MWh	Backward MWh
Forward MVarh	Forward MVarh
Backward MVarh	Backward MVarh
<i>Line thermal protection (TTR49L)</i>	
Calc. Temperature	Calculated line temperature

* *The reference angle is the phase angle of "Voltage Ch - U1"*

Table 3-146 Measured analog values



3.3.1. Current input function

3.3.1.1. Application of the current input function

The application of the current inputs depends on the correct connection of the hardware terminals and also on the correct parameter setting for the CT4 function block. This guide describes examples, based on which any other combinations can be realized.

In the applications of the current transformer hardware module, the first three current inputs (terminals 1-2, 3-4, 5-6) receive the three phase currents (IL1, IL2, IL3), the fourth input (terminals 7-8) is reserved for zero sequence current, for the zero sequence current of the parallel line or for any additional currents. Accordingly, the first three inputs have common parameters while the fourth current input needs individual setting.

The CT4 function block is an independent module in the sense that:

- It has independent parameters to be set, associated to the current inputs,
- It delivers the sampled current values for protection, measurement function blocks and for disturbance recording and for on-line displaying,
- It provides parameters for the subsequent functions blocks for scaling the measured currents.
- It performs the basic calculations
 - Fourier basic harmonic magnitude and angle,
 - True RMS value.

3.3.1.1.1. Parameter setting

3.3.1.1.1.1. Summary of the parameters

The parameters of the current input function are explained in the following tables.

Enumerated parameters

Parameter name	Title	Selection range	Default
Rated secondary current of the first three input channels. 1A or 5A is selected by parameter setting, no hardware modification is needed.			
CT4_Ch13Nom_EPar_	Rated Secondary I1-3	1A,5A	1A
Rated secondary current of the fourth input channel. 1A or 5A (0.2A, 1A) is selected by parameter setting, no hardware modification is needed.			
CT4_Ch4Nom_EPar_	Rated Secondary I4	1A,5A (0.2A, 1A)	1A
Definition of the positive direction of the first three currents, given by location of the secondary star connection point			
CT4_Ch13Dir_EPar_	Starpoint I1-3	Line,Bus	Line
Definition of the positive direction of the fourth current, given as normal or inverted			
CT4_Ch4Dir_EPar_	Direction I4	Normal,Inverted	Normal

Table 1-1 The enumerated parameters of the current input function

Floating point parameters

Parameter name	Title	Dim.	Min	Max	Default
Rated primary current of channel1-3					
CT4_Pr113_FPar_	Rated Primary I1-3	A	100	4000	1000
Rated primary current of channel4					
CT4_Pr14_FPar_	Rated Primary I4	A	100	4000	1000

Table 1-2 The floating point parameters of the current input function



NOTE: The rated primary current of the channels is not needed for the current input function block itself. These values are passed on to the subsequent function blocks.

3.3.1.1.1.2. Setting the rated secondary current

The scaling of the currents (even hardware scaling) depends on parameter setting.

Rated Secondary I1-3 and Rated Secondary I4

Select the rated secondary current according to the nominal data of the main current transformer. The options to choose from are 1A or 5A (in special applications, 0.2A or 1A). This parameter influences the internal number format and, naturally, accuracy. (A small current is processed with finer resolution if 1A is selected.) The first parameter is common for the first three channels and the second one is applied for the fourth channel.

NOTE: when selecting from the available choice, no hardware modification is needed.

3.3.1.1.1.3. Setting the positive direction of the currents

The positive direction of the currents influences the correct operation of directionality (e.g. distance protection, directional overcurrent protection, power calculation, etc.) If needed, the currents can be inverted by setting parameters. This is equivalent to interchanging the two wires, connecting the currents to the inputs.

Starpoint I1-3 and Direction I4.

Starpoint I1-3 applies to each of the channels IL1, IL2 and IL3. The example of Figure 1-1 below shows the connection and the correct parameter setting for Starpoint I1-3=Line. The current L1 is connected to terminal No1 of the CT input, the current L2 to No3, and the current L3 to No5. The common point of the CT inputs is the connected No2-No4-No6. This point leads the residual current to the input No7. The connection point No8 is connected with the fourth wire to the star-point of the CTs. This application of the fourth channel is the "Normal" direction.

If the currents are connected not this way then change the parameter values accordingly.

3.3.1.1.1.4. Setting the rated primary current

These parameters are needed only to display the currents (and powers) in primary scale. The protection function apply secondary values, these parameters are not needed for protection functions.

Rated Primary I1-3 and Rated Primary I-4

Select the rated primary currents according to the nominal data of the main current transformers. The first parameter (Rated Primary I1-3) is common for the first three channels and the second (Rated Primary I-4) is for the fourth channel.

3.3.1.1.2. Application of the on-line measurements in commissioning

The **measured values** of the current input function block are listed and explained in the Table below.

Measured value	Dim.	Explanation
Current Ch - I1	A(secondary)	Fourier basic component of the current in channel IL1
Angle Ch - I1	degree	Vector position of the current in channel IL1
Current Ch - I2	A(secondary)	Fourier basic component of the current in channel IL2
Angle Ch - I2	degree	Vector position of the current in channel IL2
Current Ch - I3	A(secondary)	Fourier basic component of the current in channel IL3
Angle Ch - I3	degree	Vector position of the current in channel IL3
Current Ch - I4	A(secondary)	Fourier basic component of the current in channel IL4
Angle Ch - I4	degree	Vector position of the current in channel IL4

Table 1-3 The measured analogue values of the current input function

NOTE1: The scaling of the Fourier basic component is such that if pure sinusoid 1A RMS of the rated frequency is injected, the displayed value is 1A.

NOTE2: The reference of the vector position depends on the device configuration. If a voltage input module is included, then the reference vector (vector with angle 0 degree) is the vector calculated for the first voltage input channel of the first applied voltage input module. If no voltage input module is configured, then the reference vector (vector with angle 0 degree) is the vector calculated for the first current input channel of the first applied current input module. (The first input module is the one, located closer to the CPU module.)

3.3.1.1.3. Examples

When the vector position of the currents are relevant (e.g. distance protection, directional overcurrent protection, power measurement, etc.) then mind the correct connection of the instrument transformers and the related parameter setting. If the wires of the secondary cables are interchanged then change also the related parameter values.

3.3.1.1.3.1. Residual current measurement

Figure 1-1 shows a connection example with 3I₀ measurement. The star-point of the CT-s is towards the line, L1 is connected to terminal No1 of the CT input, L2 to No3, L3 to No5. The common point of the CT inputs is the connected No2-No4-No6. This point leads the residual current to the input No7. The connection point No8 is connected with the fourth wire to the star-point of the CTs.

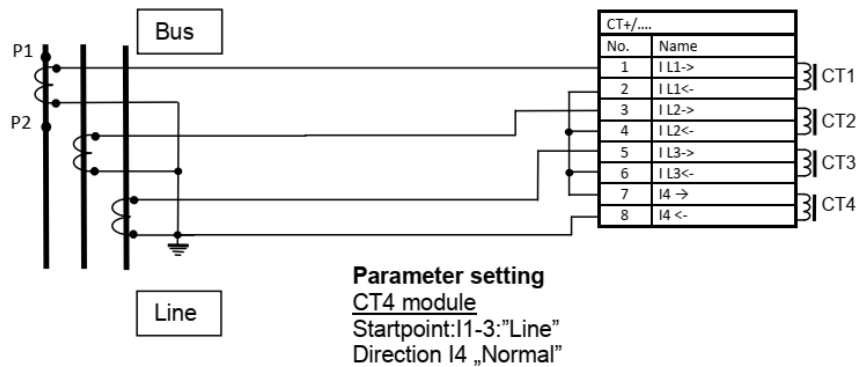
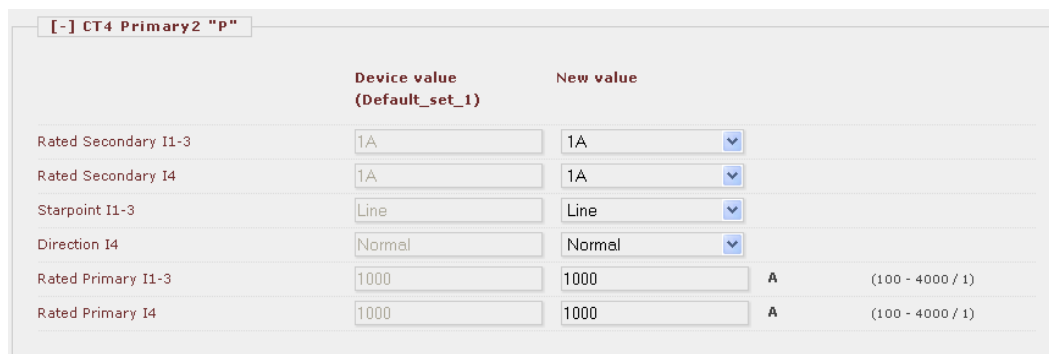

Figure 1-1 Example: CT connection with 3I₀ measurement

The related proposed parameter setting is the screen-shot of Figure 1-2. Parameter “Starpoint I1-3” is set to “Line”, indicating that the star-point is toward the protected object (line). The parameter “Direction I4” is set to “Normal”, indicating that the residual current flows in to terminal No7 and the star point of the primary current transformer is toward the protected object (line).



	Device value (Default_set_1)	New value		
Rated Secondary I1-3	1A	1A		
Rated Secondary I4	1A	1A		
Starpoint I1-3	Line	Line		
Direction I4	Normal	Normal		
Rated Primary I1-3	1000	1000	A	(100 - 4000 / 1)
Rated Primary I4	1000	1000	A	(100 - 4000 / 1)

Figure 1-2 Example: Parameter setting, according to Figure 1-1

In case of normal operation of the network, the correct connection of the CT-s and the related parameter setting can be checked using the “On-line” measurements. Disconnect one phase of the protected line, e.g. L1. The expected result is shown in Figure 1-3. The current is missing in phase L1 (Current Ch-I1 = 0) and the measured 3I₀ value is the vector sum of the remaining I₂+I₃. (Value of “Current Ch - I4” with the related “Angle - I4”).

NOTE: If in this test, only the secondary current is disclosed using a short measuring cable, then the measured current in this phase is usually not zero, due to the current distribution between the low-impedance input and the impedance of the measuring cable. For correct result, additionally to the short-circuit, also the disconnection of this input is needed. In this example the reference vector is the vector of the first voltage channel (not shown in the screenshot).

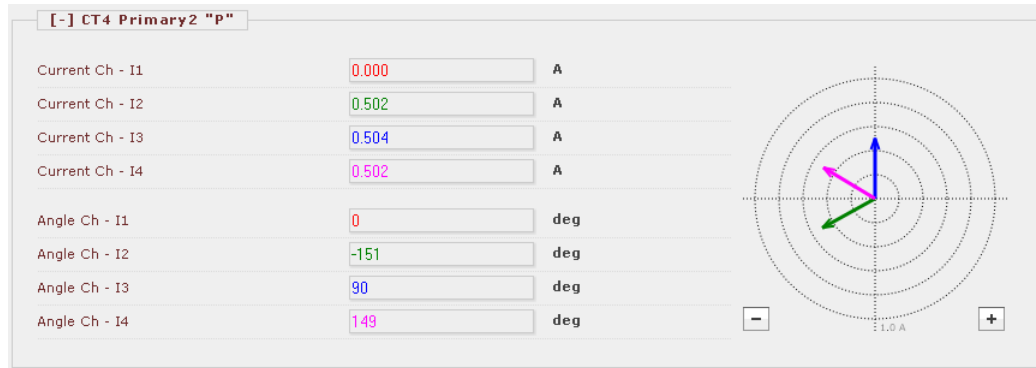

Figure 1-3 Example: Checking the current connection

3.3.1.1.3.2. Application of core-balanced CT

Figure 1-4 shows a connection example with 3I₀ measurement. The star-point of the CT-s is towards the line, L1 is connected to terminal No1 of the CT input, L2 to No3, L3 to No5. The common point of the CT inputs is the connected No2-No4-No6. The separately measured residual current is connected with the same polarity to terminals 7-8.

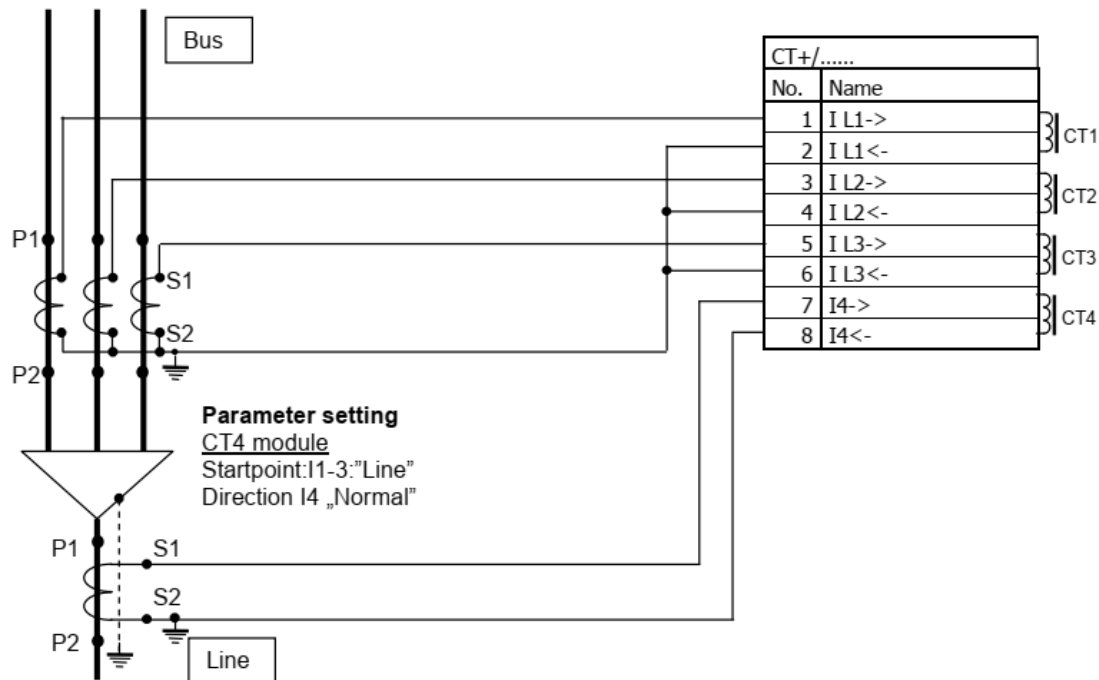

Figure 1-4 Example: CT connection with core-balance CT application

This figure also indicates the proposed parameter values for this connection. The checking is similar to that, shown in Figure 1-3.

3.3.2. AIC current input function

3.3.2.1. Application of the AIC current input function

If the factory configuration includes an AIC input hardware module, the AIC current input function block is automatically configured among the software function blocks. Separate current input function blocks are assigned to each AIC current input hardware module.

The AIC current input module accepts transducers current outputs. The AIC module has four channels, they can measure unipolar and bipolar current values in wide ranges. (See EuroProt+ hardware description document.) The transducer converts any physical quantity to DC current values.

The transmitters can be connected by wiring methods, shown in Figure 1–1, Figure 1–2 and Figure 1–3.

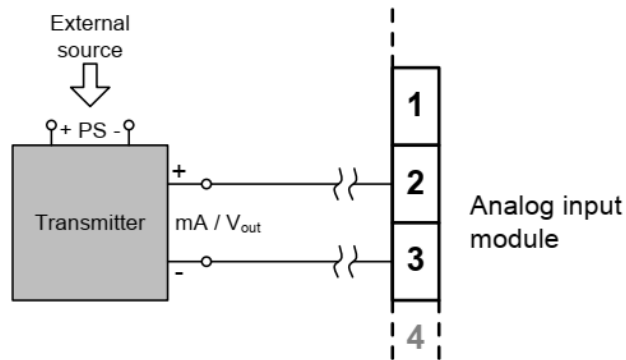

Figure 1–1 2-wire AIC wiring without 12 V excitation

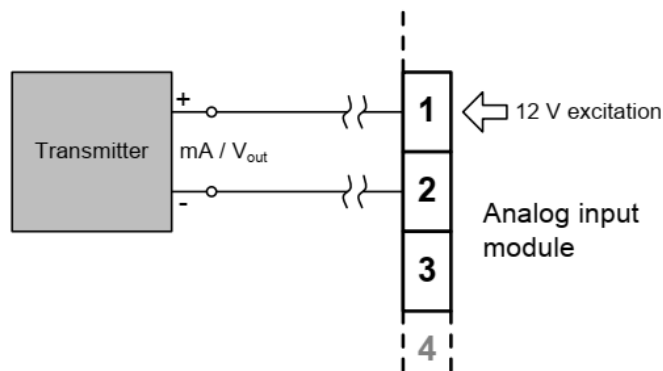

Figure 1–2 2-wire AIC wiring with 12 V excitation

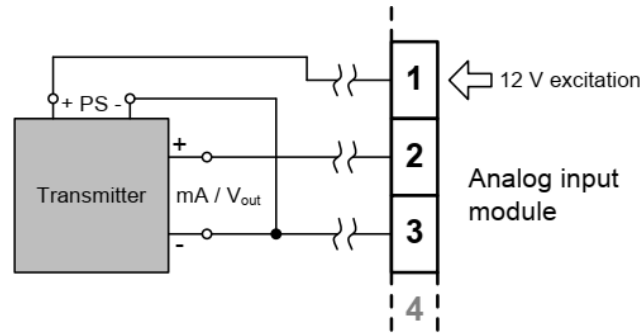

Figure 1-3 3-wire AIC wiring with 12 V excitation

The channels of the module are independent of each other. To each channel a dedicated measuring module is assigned. These measuring modules are described in a separate document: “**GGIOmA current measurement module function block description**”.

3.3.2.2. Technical summary

3.3.2.2.1. Technical data

The technical data of the AIC analog current input module are related to the hardware module. This is described in the document “**EuroProt+ Hardware description**, Chapter 11: analog input module”.

3.3.2.2.2. Summary of the parameters

The parameters of the AIC analog current input function are explained in the following table.

Enumerated parameters

Parameter name	Title	Selection range	Default
Polarity of Channel 1			
AIC_Ch1Dir_EPar_1	Direction - Ch1	Normal,Inverted*	Normal
Polarity of Channel 2			
AIC_Ch2Dir_EPar_1	Direction – Ch2	Normal,Inverted*	Normal
Polarity of Channel 3			
AIC_Ch3Dir_EPar_1	Direction – Ch3	Normal,Inverted*	Normal
Polarity of Channel 4			
AIC_Ch4Dir_EPar_1	Direction – Ch4	Normal,Inverted*	Normal

*Figures 1-1, 1-2 and 1-3 show “Normal” connection polarity

Table 1-1 The enumerated parameters of the current input function

NOTE: The function block has no input and output binary signals, the graphic logic editor does not show this function block.

3.3.3. Voltage input function

3.3.3.1. Application of the voltage input function

The application of the voltage inputs depends on the correct connection of the hardware terminals and also on the correct parameter setting for the VT4 function block. This guide describes examples, based on which any other combinations can be realized.

In the applications of the voltage transformer hardware module, the first three voltage inputs receive the three phase voltages (UL1, UL2, UL3), the fourth input is reserved for zero sequence voltage, for the busbar voltage if synchronized switching is applied or for any additional voltages. Accordingly, the first three inputs have common parameters while the fourth voltage input needs individual setting.

The VT4 function block is an independent module in the sense that:

- It has independent parameters to be set, associated to the voltage inputs,
- It delivers the sampled voltage values for protection, measurement function blocks and for disturbance recording,
- It provides parameters for the subsequent functions blocks for scaling the measured voltages.
- It performs the basic calculations
 - Fourier basic harmonic magnitude and angle,
 - True RMS value.

3.3.3.1.1. Parameter setting

3.3.3.1.1.1. Summary of the parameters

The parameters of the voltage input function are explained in the following tables.

Enumerated parameters

Parameter name	Title	Selection range	Default
Rated secondary voltage of the input channels. 100 V or 200V is selected by parameter setting, no hardware modification is needed.			
VT4_Type_EPar_	Range	Type 100,Type 200	Type 100
Connection of the first three voltage inputs (main VT secondary)			
VT4_Ch13Nom_EPar_	Connection U1-3	Ph-N, Ph-Ph, Ph-N-Isolated	Ph-N
Selection of the fourth channel input: phase-to-neutral or phase-to-phase voltage			
VT4_Ch4Nom_EPar_	Connection U4	Ph-N,Ph-Ph	Ph-Ph
Definition of the positive direction of the first three input channels, given as normal or inverted			
VT4_Ch13Dir_EPar_	Direction U1-3	Normal,Inverted	Normal
Definition of the positive direction of the fourth voltage, given as normal or inverted			
VT4_Ch4Dir_EPar_	Direction U4	Normal,Inverted	Normal

Table 1-1 The enumerated parameters of the voltage input function

Integer parameter

Parameter name	Title	Unit	Min	Max	Step	Default
Voltage correction						
VT4_CorrFact_IPar_	VT correction	%	100	115	1	100

Table 1-2 The integer parameter of the voltage input function



Floating point parameters

Parameter name	Title	Dim.	Min	Max	Default
Rated primary voltage of channel 1, 2, 3					
VT4_PriU13_FPar	Rated Primary U1-3	kV	1	1000	100
Rated primary voltage of channel 4					
VT4_PriU4_FPar	Rated Primary U4	kV	1	1000	100

Table 1-3 The floating point parameters of the voltage input function

NOTE: The rated primary voltage of the channels is not needed for the voltage input function block itself. These values are passed on to the subsequent function blocks.

3.3.3.1.1.2. Setting the rated secondary voltage

The scaling of the voltage depends on parameter setting.

Range

There are basically two standard voltage transformer types: one with secondary rated voltage 100 V, the other with 200 V. Select the parameter value respectively: Type 100, Type 200. No hardware modification is needed. This parameter influences the internal number format and, naturally, accuracy. (A small voltage is processed with finer resolution if 100V is selected.)

VT correction

In some cases the rated secondary of the voltage transformers is not 100V but e.g. 110 V. This parameter is to correct this difference, if the rated secondary voltage of the main voltage transformer does not match the rated input of the device. As an example: if the rated secondary voltage of the main voltage transformer is 110V, then select Type 100 for the parameter "Range" and the required value to set here is 110%.

3.3.3.1.1.3. Setting the connection and the positive direction of the voltages

The connection and direction parameters of the first three VT secondary windings must be set to reflect actual physical connection of the main VTs.

Connection U1-3.

The selection can be: "Ph-N", "Ph-Ph" or "Ph-N-Isolated".

The *Ph-N* option is applied in solidly grounded networks, where the measured phase voltage is never above $1.5 \cdot U_n$. In this case the primary rated voltage of the VT must be the value of the rated PHASE-TO-NEUTRAL voltage.

The *Ph-N-Isolated* option is applied in compensated or isolated networks, where the measured phase voltage can be above $1.5 \cdot U_n$ even in normal operation. In this case the primary rated voltage of the VT must be the value of the rated PHASE-TO-PHASE voltage.

The *Ph-Ph* option is to be selected if phase-to-phase voltage is connected to the VT input of the device. Here, the primary rated voltage of the VT must be the value of the rated PHASE-TO-PHASE voltage. This option must not be selected if the distance protection function or



directional overcurrent protection function is supplied from the VT input.

Connection U4

The fourth input is reserved for zero sequence voltage or for a voltage from the other side of the circuit breaker for synchronized switching. Accordingly, the connected voltage must be identified with parameter setting Connection U4. Here, phase-to-neutral or phase-to-phase voltage can be selected: “Ph-N”, “Ph-Ph”

Direction U1-3

If needed, the phase voltages can be inverted by setting the parameter Direction U1-3. This selection applies to each of the channels UL1, UL2 and UL3. The primary/secondary connection of the VT windings is generally star/star connected and the phase voltages signed with • are connected to the VT4 terminals 1-3-5. In this case the parameter setting is „Normal”. Select “Inverted” to the parameter Direction U1-3 in case of inverted connection of phase voltages.” (See also Figure 1-1 in setting example.)

Direction U4

This parameter applies to the channel UL4. If the voltage signed with • is connected to the VT4 terminal 7 the parameter setting is „Normal”. Select “Inverted” to the parameter Direction U4 in case of inverted connection of the voltage. This inversion may be needed in protection functions such as distance protection or for any functions with directional decision, or for checking the voltage vector positions.

Figure 1-1 shows an example with harmonized connection and parameter setting.

If the voltages are connected not this way then change the parameter values accordingly.

3.3.3.1.1.4. Setting the rated primary voltage

These parameters are needed only to display the voltages (and powers) in primary scale. The protection functions apply secondary values, these parameters are not needed for protection functions.

Rated Primary U1-3 and Rated Primary U-4

Select the rated primary voltages according to the nominal data of the main voltage transformers. The two parameters are: common for the first three channels and one for the fourth channel respectively.

3.3.3.1.2. Application of the on-line measurements in commissioning

The performed basic calculation results the Fourier basic harmonic magnitude and angle value of the voltages. These results are processed by subsequent protection function blocks and they are available for on-line displaying as well.

3.3.3.1.2.1. Summary of the on-line measurements

The **measured values** of the voltage input function block.

Measured value	Dim.	Explanation
Voltage Ch - U1	V(secondary)	Fourier basic component of the voltage in channel UL1
Angle Ch - U1	degree	Vector position of the voltage in channel UL1
Voltage Ch - U2	V(secondary)	Fourier basic component of the voltage in channel UL2
Angle Ch - U2	degree	Vector position of the voltage in channel UL2
Voltage Ch - U3	V(secondary)	Fourier basic component of the voltage in channel UL3
Angle Ch - U3	degree	Vector position of the voltage in channel UL3
Voltage Ch - U4	V(secondary)	Fourier basic component of the voltage in channel U4
Angle Ch - U4	degree	Vector position of the voltage in channel U4

Table 1-4 The measured analogue values of the voltage input function

NOTE1: The scaling of the Fourier basic component is such that if pure sinusoid 57V RMS of the rated frequency is injected, the displayed value is 57V.

NOTE2: The reference vector (vector with angle 0 degree) is the vector calculated for the first voltage input channel of the first applied voltage input module. (The first voltage input module is the one, configured closer to the CPU module.)

3.3.3.1.3. Examples

When the vector position of the voltages are relevant (e.g. distance protection, directional overcurrent protection, power measurement, synchrocheck, etc.) then mind the correct connection of the instrument transformers and the related parameter setting. If the wires of the secondary cables are interchanged then change also the related parameter values.

3.3.3.1.3.1. Phase voltage and residual voltage measurement

Figure 1-1 shows the phase voltage measurement and also the residual voltage measurement e.g. for residual directional overcurrent protection function. In this example the residual voltage is measured in open delta of the VT secondary coils. The network is supposed to be compensated. This figure also indicates the proposed parameter values.

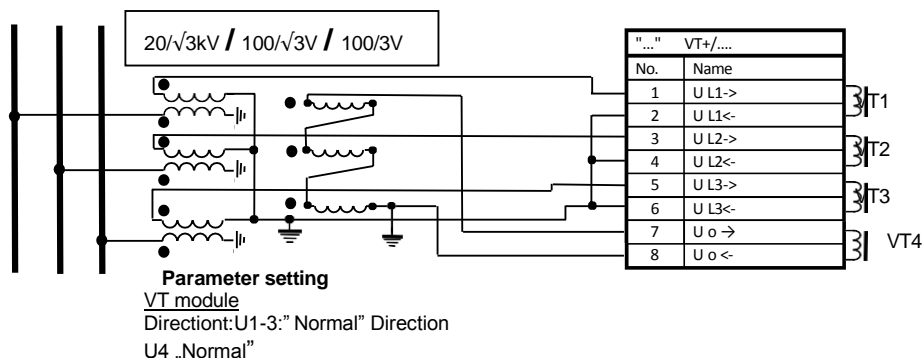

Figure 1-1 Example: Phase voltage and residual voltage measurement

Range	Type 100	Description
Connection U1-3	Ph-N-Isolated	This indicates that the VT primary is connected between the conductor and the ground (in this example in compensated network). This could be Ph-N or Ph-Ph in other application. (NOTE: If the neutral of the system is not grounded, select Ph-N-Isolated)
Connection U4	Ph-Ph	In case of earth fault the open delta measures 100 V. This corresponds to the phase-to-phase value
Direction U1-3	Normal	Figure 1-1 shows the normal VT connection, i.e. the signed • phase wires are connected to the terminals 1-3-5. (Select "Inverted" in case of inverted connection.)
Direction U4	Normal	Figure 1-1 shows the normal VT connection, i.e. the signed • wire of the open delta of VT-s is connected to the terminal 7. (Select "Inverted" in case of inverted connection.)
VT correction	100	If the rated secondary value of the VT is e.g. 110 V then select this correction value to 110%.
Rated Primary U1-3	20	Setting, according to the VT rated voltage, applied at the primary side. This parameter is used for scaling the displayed values only.
Rated Primary U4	11.55	This parameter is used for scaling the displayed values only. In case of earth fault, the open delta measures 100 V. In primary value it is displayed as the phase voltage in the 20 kV network.

Table 1-5 Example parameters for the voltage input function

3.3.3.1.3.2. Syncrocheck using phase-to neutral voltage

Figure 1-2 shows the application of the fourth voltage input of the VT module for syncrocheck function. Here UL2 of the busbar voltage is used for this purpose.

NOTE: Among syncrocheck parameters set "Voltage select" parameter to "L2-N".

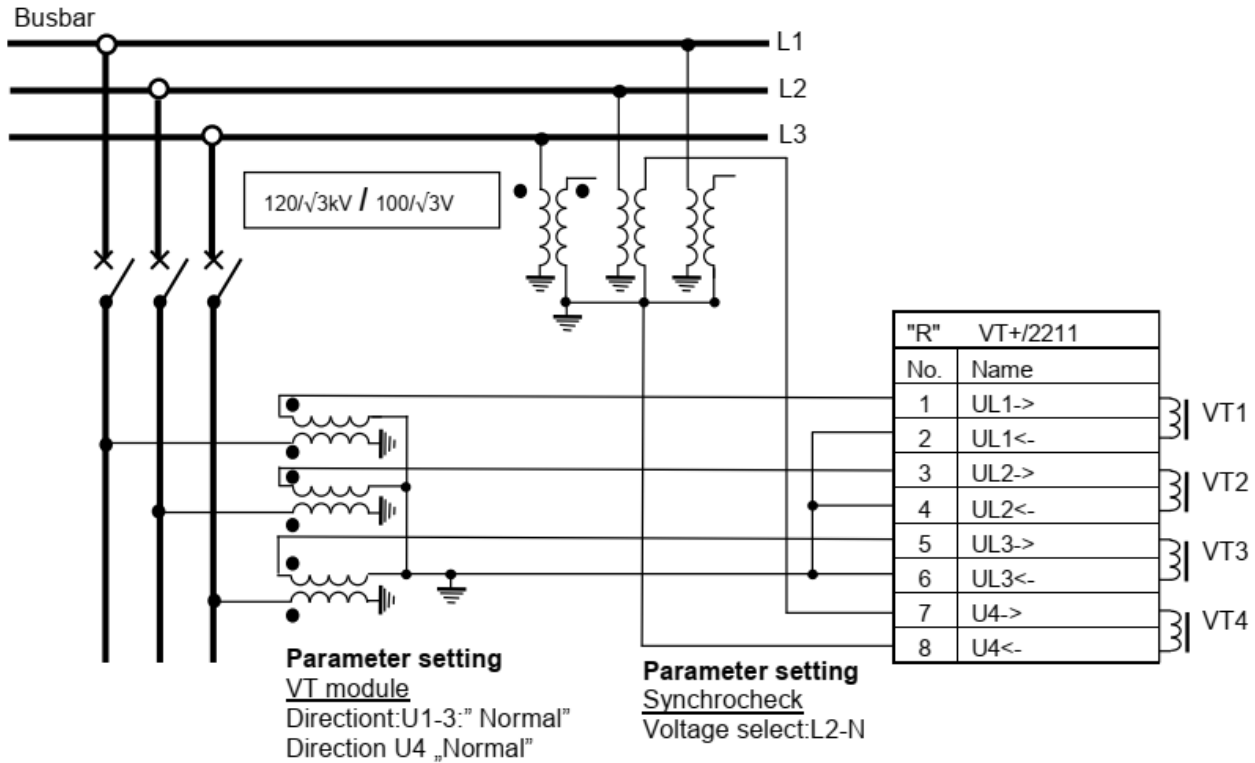

Figure 1-2 Example: Syncrocheck, using phase-to-neutral voltage

Figure 1-3 shows the screenshot indicating the proposed parameter values.

[-] VT4 module "U"				
	Device value (Default_set_1)	New value		
Range	Type 100	Type 100		
Connection U1-3	Ph-N	Ph-N		
Connection U4	Ph-N	Ph-N		
Direction U1-3	Normal	Normal		
Direction U4	Normal	Normal		
VT correction	100	100	%	(1.00 - 115 / 1)
Rated Primary U1-3	69.28	69.28	kV	(1.00 - 1000.00 / 0.01)
Rated Primary U4	69.28	69.28	kV	(1.00 - 1000.00 / 0.01)

Figure 1-3 Example:Parameters for syncrocheck, using phase-to-neutral voltage

The "On-line window" of the VT4 input module shows the checking the correct voltage vector position. When the line is connected to the busbar, i.e. the CB is closed, in this example the U4 voltage is expected to have the same value and position as U2. See Figure 1-4.

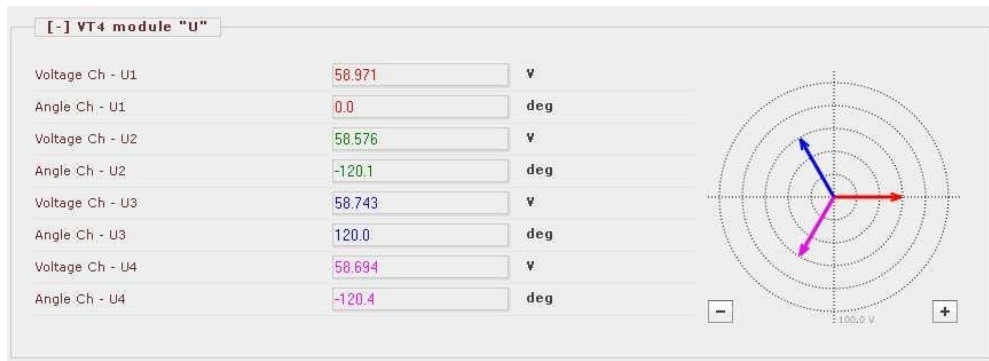

Figure 1-4 Example: On-line measurement for synchrocheck, using phase-to-neutral voltage

3.3.3.1.3.3. Synchrocheck using phase-to-phase voltage

Figure 1-5 shows the application of the fourth voltage input of the VT module for synchrocheck function. Here UL1-UL3 line-to-line signal of the busbar voltage is used for this purpose.

NOTE: Among synchrocheck parameters set "Voltage select" parameter to "L3-L1". This selection is opposite to that, of the connected voltage. This can be corrected selecting the "Direction U4" parameter value to "Inverse".

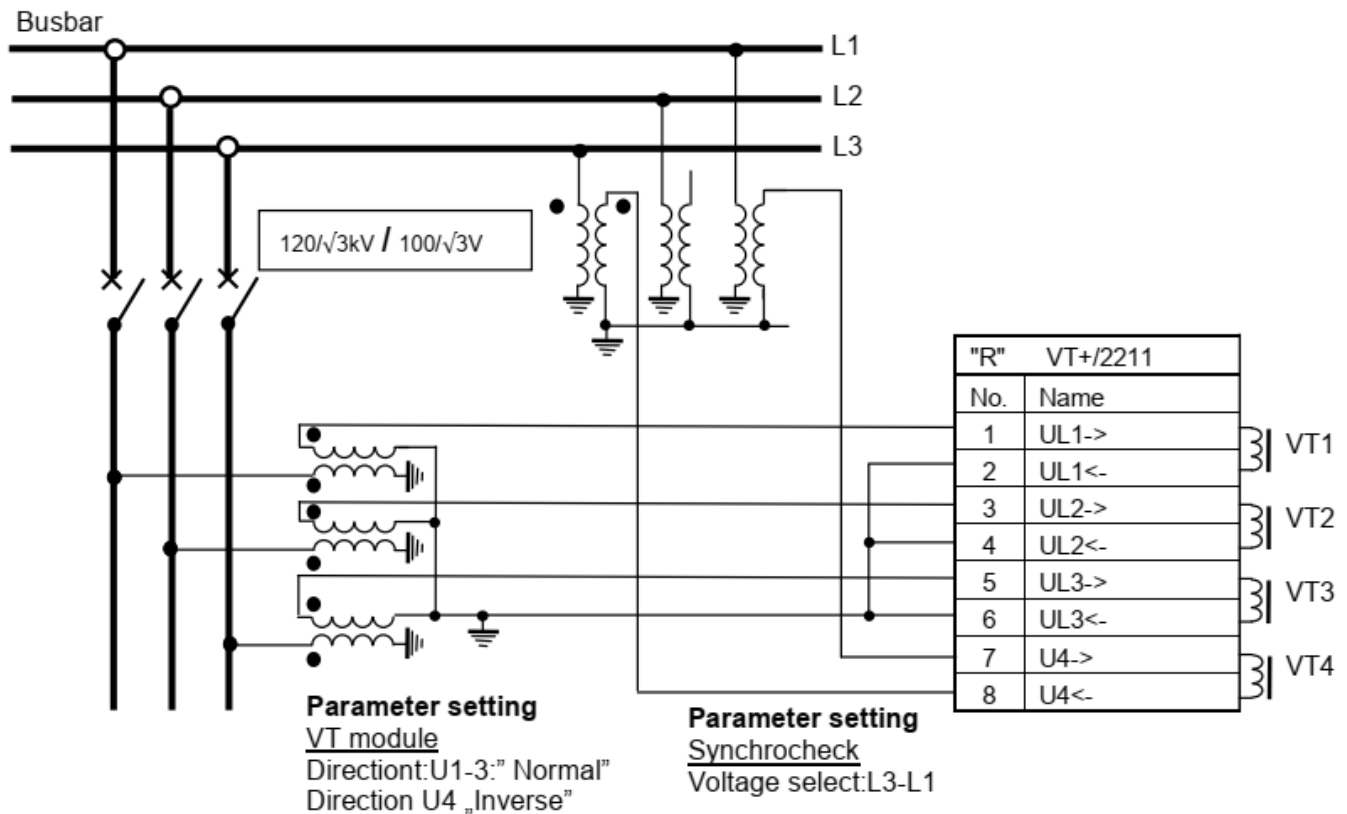

Figure 1-5 Example: Synchrocheck, using phase-to-phase voltage

Figure 1-6 shows the proposed parameter values for the connection shown above.

[-] VT4 module "U"

	Device value (Default_set_1)	New value		
Range	Type 100	Type 100		
Connection U1-3	Ph-N	Ph-N		
Connection U4	Ph-Ph	Ph-Ph		
Direction U1-3	Normal	Normal		
Direction U4	Inverted	Inverted		
VT correction	100	100	%	(100 - 115 / 1)
Rated Primary U1-3	69.28	69.28	kV	(1.00 - 1000.00 / 0.01)
Rated Primary U4	120.00	120.00	kV	(1.00 - 1000.00 / 0.01)

Figure 1-6 Example: Parameters for syncrocheck, using phase-to-phase voltage

The "On-line window" of the VT4 input module shows the checking the correct voltage vector position. When the line is connected to the busbar, i.e. the CB is closed, in this example the U4 voltage is expected to have a vector identical with the voltage difference U3-U1. See Figure 1-7.

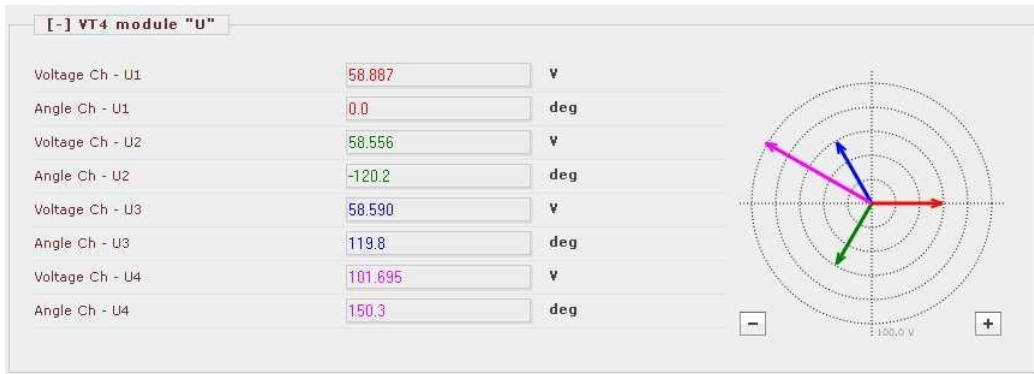
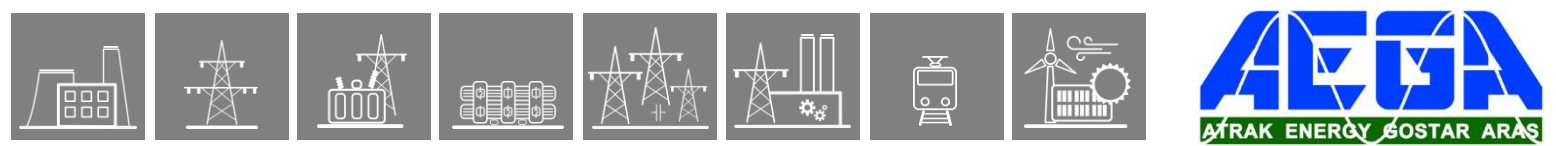

Figure 1-7 Example: On-line measurement for syncrocheck, using phase-to-phase voltage

NOTE that due to the reverse connection of the voltage difference and the parameter setting also reverted by "Inverse" setting, the indicated U4 vector corresponds to the parameter "Voltage select=L3-L1" among syncrocheck parameters.



3.3.4. Line and frequency measurement functions

3.3.4.1. Application

The input values of the EuroProt+ devices are the secondary signals of the voltage transformers and those of the current transformers when they are available in the actual configuration.

These signals are pre-processed by the “VT4 module” voltage input function block and by “CT4 module” the current input function block. These function blocks are described in separate documents. The pre-processed values include the Fourier basic harmonic phasors of the voltages and currents and the true RMS values. Additionally, it is in these function blocks that parameters are set concerning the voltage ratio of the primary voltage transformers and current ratio of the current transformers.

Based on the pre-processed values and the measured transformer parameters, the measurement function blocks calculate - depending on the hardware and software configuration - the primary RMS values of the voltages and currents and some additional values such as active and reactive power, symmetrical components of voltages and currents. These values are available as primary quantities and they can be displayed on the on-line screen of the device or on the remote user interface of the computers connected to the communication network and they are available for the SCADA system using the configured communication system.

3.3.4.2. Mode of operation

The **inputs** of the line measurement function are

- the Fourier components and true RMS values of the measured voltages and currents,
- frequency measurement,
- parameters.

The **outputs** of the line measurement function are

- displayed measured values,
- reports to the SCADA system.

NOTE: the scaling values are entered as parameter setting for the “Voltage transformer input” function block and for the “Current transformer input” function block.

3.3.4.3. The measurement

3.3.4.3.1. The measured values; variants of the function

There are six variants of the MXU function, based on their **measured values**. Parameters and measurements are alike for each. The **type of the variant** is shown in the *function block name*:

- Line Measurement (*MXU_LM*)
- Frequency Measurement (*MXU_F*)
- Voltage measurement (*MXU_V*)
- Voltage measurement (*MXU_V1*) (single voltage)
- Current measurement (*MXU_C*)
- Current measurement (*MXU_C1*) (single current)

Table 1-1 Measured values of each variant

ON-LINE MEASURED VALUE	EXPLANATION	MXU FUNCTION BLOCK VARIANT					
		LM	F	V	V1	C	C1
MXU_P_OLM_	Active Power – P (Fourier base harmonic value)	X					
MXU_Q_OLM_	Reactive Power – Q (Fourier base harmonic value)	X					
MXU_S_OLM_	Apparent Power – S (Fourier base harmonic value)	X					
MXU_Fi_OLM_	Power factor	X					
MXU_I1_OLM_	Current L1	X				X	X
MXU_I2_OLM_	Current L2	X				X	
MXU_I3_OLM_	Current L3	X				X	
MXU_Ipos_OLM_	Calculated positive seq. current	X				X	
MXU_Ineg_OLM_	Calculated negative seq. current	X				X	
MXU_3Io_OLM_	Calculated 3Io	X				X	
MXU_U1_OLM_	Voltage L1	X		X	X		
MXU_U2_OLM_	Voltage L2	X		X			
MXU_U3_OLM_	Voltage L3	X		X			
MXU_U12_OLM_	Voltage L12	X		X			
MXU_U23_OLM_	Voltage L23	X		X			
MXU_U31_OLM_	Voltage L31	X		X			
MXU_Upos_OLM	Calculated positive seq. voltage	X		X			
MXU_Uneg_OLM_	Calculated negative seq. voltage	X		X			
MXU_3Uo_OLM_	Calculated 3Uo	X		X			
MXU_f_OLM_	Frequency		X	X			

3.3.4.3.2. The measurement modes

Regarding the power measurements there are two possibilities for the measurement modes. The first one is the “ThreePhase”-method, where all three measured voltages and currents are considered in the power calculation. The second one is the “Aron”-method, where two phase-to-phase voltages and two phase currents are taken into the calculation. This method has correct results only in case when the voltages and currents are symmetrical. The user can choose the mode with the “Measurement mode” parameter. For the “Aron”-method there are three options:

Table 1-2 Explanation for the Aron measurement modes

Measurement mode	Used phase-currents	Used phase-to-phase voltages
Aron L2-L3	L2, L3	L1-L2, L3-L1
Aron L3-L1	L1, L3	L1-L2, L2-L3
Aron L1-L2	L1, L2	L2-L3, L3-L1



If the “Connection U1-3” parameter of the *VT4 module* function block is set to “Ph-Ph”, the “ThreePhase”-method cannot be used for the power measurements here, so either of the “Aron” methods must be set for it. Otherwise, the device will provide a warning signal (yellow Status LED, “General param. error” message).

3.3.4.4. Reporting the measured values and the changes

It is usual for the SCADA systems that they sample the measured and calculated values in regular time periods and additionally they receive the changed values as reports at the moment when any significant change is detected in the primary system. The “Line measurement” function block performs such reporting for the SCADA system. Three parameters define this reporting:

- *Report Deadband* for choosing the type of reporting, or disabling the reporting
- *Deadband Value* for defining the deadband width
- *Range (value)* for evaluating the “out-of-range” condition

The usage of these parameters is explained in the following chapters.

3.3.4.4.1. “Amplitude” mode of reporting

If the “Amplitude” mode is selected for reporting, a report is generated if the measured value leaves the deadband around the previously reported value. As an example, [Figure 1-1](#) shows that the current becomes higher than the value reported in “report1” PLUS the Deadband value, this results “report2”, etc.

For this mode of operation, the Deadband parameters are explained in the figure below.

NOTE: The “Range” parameters are needed to evaluate a measurement as “out-of-range”.

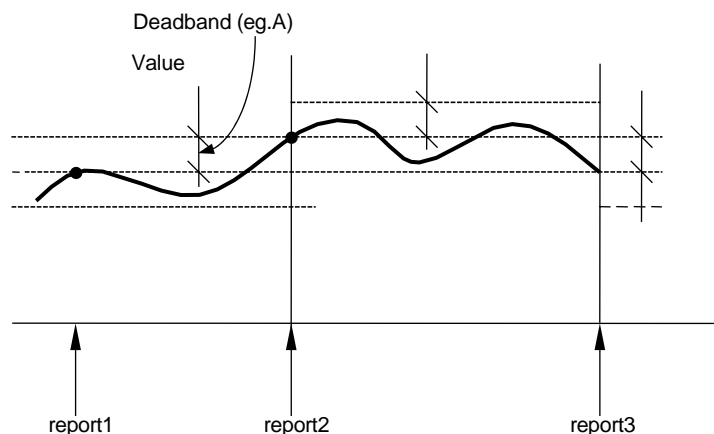

Figure 1-1 Reporting if “Amplitude” mode is selected

3.3.4.4.2. “Integrated” mode of reporting

If the “Integrated” mode is selected for reporting, a report is generated if the time integral of the measured value since the last report gets becomes larger, in the positive or negative direction, then the (deadband*1sec) area. As an example, [Figure 1-2](#) shows that the integral of the current in time becomes higher than the Deadband value multiplied by 1sec, this results “report2”, etc.

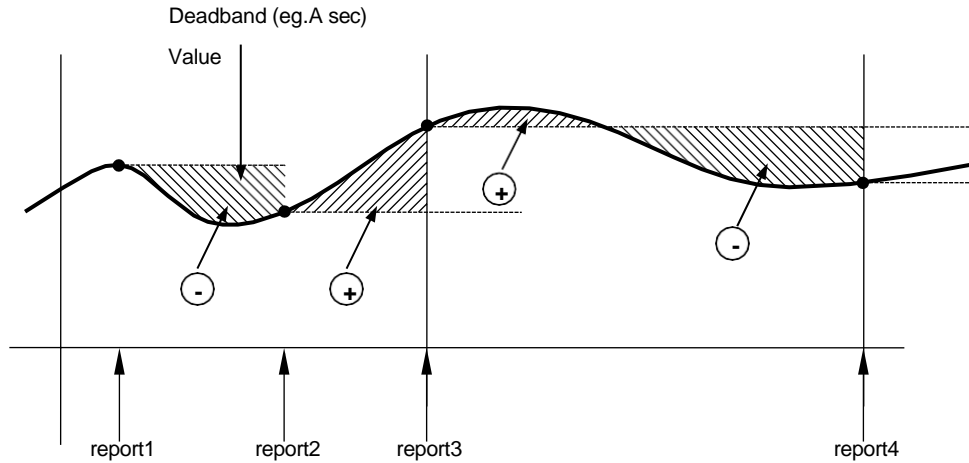

Figure 1-2 Reporting if “Integrated” mode is selected

3.3.4.4.3. Periodic reporting

Periodic reporting is generated independently of the changes of the measured values when the defined time period elapses. If the reporting time period is set to 0, then no periodic reporting is performed for this quantity.

Applying periodic reporting and setting up its interval is done by using the **Communication configurator**, a part of the **EuroCAP** software (see its description for detailed information).

Once the “Trigger period” property is set to “True”, the “Integrity period” setting becomes available to set (in milliseconds). As an example, see the picture below.

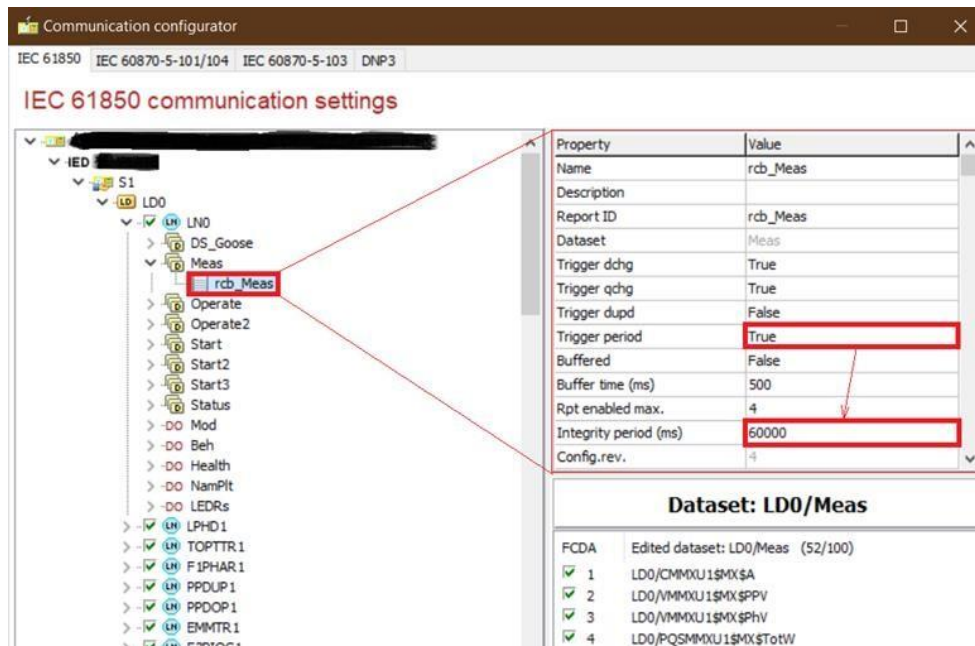
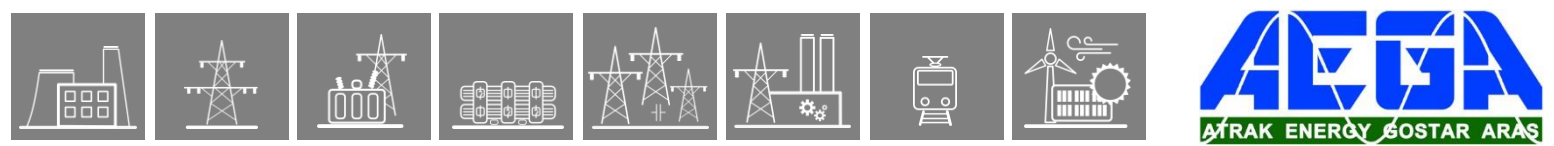

Figure 1-3 Setting up periodic reporting in EuroCAP



3.3.4.4.4. Zero-point clamping

A measured value under the zero-point clamping limit is cut off to zero.

- Three-phase current measurement 0.2% of nominal (I_n)
- Three-phase voltage measurement 2% of nominal (U_n)
- Residual current measurement 0.2% of nominal (I_n)
- Residual voltage measurement 2% of nominal (U_n)
- Phase sequence current measurement 0.2% of the nominal (I_n)
- Phase sequence voltage measurement 2% of the nominal (U_n)
- Three-phase power and energy measurement 0.23% of the nominal (S_n)

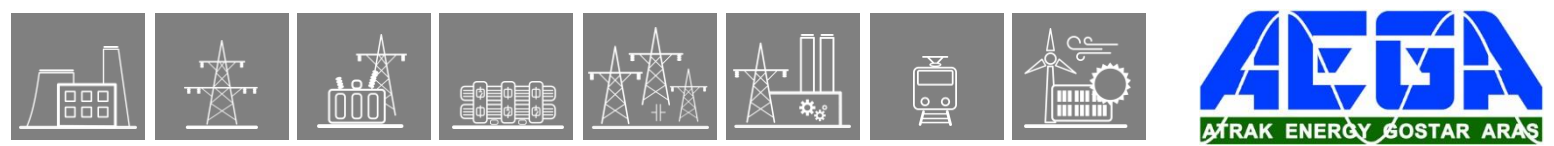

3.3.4.5. Line and frequency measurement functions overview

3.3.4.5.1. Settings

3.3.4.5.1.1. Parameters

The following parameters are the parameters of the Line Measurement and Frequency measurement function blocks (LM and F variants). The other functions' parameters follow the pattern of the corresponding measured values.

Table 2-1 Parameters of the line measurement function

TITLE	DIM	RANGE**	STEP	DEFAULT	EXPLANATION
Measurement mode	-	Aron L2-L3, Aron L3-L1, Aron L1-L2, ThreePhase	-	ThreePhase	Measurement mode
Report Deadband - U	-	Off, Amplitude, Integrated	-	Amplitude	Selection of the reporting mode for voltage measurement
Deadband Value - Uph-N	kV*	0.10 – 100.00	0.01	5	Deadband value for the phase-to-neutral voltage
Range Value - Uph-N	kV*	1.0 – 1000.0	0.1	231	Range value for the phase-to-neutral voltage
Deadband Value Uph-ph	kV*	0.10 – 100.00	0.01	5	Deadband value for the phase-to-phase voltage
Range Value - Uph-ph	kV*	1.0 – 1000.0	0.1	400	Range value for the phase-to-neutral voltage
Deadband Value - U Res	kV*	0.10 – 100.00	0.01	5	Deadband value for the residual voltage
Range Value - U Res	kV*	1.0 – 1000.0	0.1	20	Range value for the residual voltage
Deadband Value - Uneg	kV*	0.10 – 100.00	0.01	5	Deadband value for the negative seq. voltage
Range Value - Uneg	kV*	1.0 – 1000.0	0.1	231	Range value for the negative seq. voltage
Deadband Value - Upos	kV*	0.10 – 100.00	0.01	5	Deadband value for the positive seq. voltage
Range Value - Upos	kV*	1.0 – 1000.0	0.1	231	Range value for the positive seq. voltage
Report Deadband - I	-	Off, Amplitude, Integrated	-	Amplitude	Selection of the reporting mode for current measurement
Deadband Value - I	A	1 – 2000	1	10	Deadband value for the current
Range Value - I	A	1 – 5000	1	500	Range value for the current
Deadband Value - I Res	A	1 – 500	1	10	Deadband value for the residual current
Range Value - I Res	A	1 – 1000	1	100	Range value for the residual current
Deadband Value - Ineg	A	1 – 2000	1	10	Deadband value for the negative seq. current
Range Value - Ineg	A	1 – 5000	1	500	Range value for the negative seq. current
Deadband Value - Ipos	A	1 – 2000	1	10	Deadband value for the positive seq. current

Range Value - Ipos	A	1 – 5000	1	500	Range value for the positive seq. current
Report Deadband - P	-	Off, Amplitude, Integrated	-	Amplitude	Selection of the reporting mode for active power measurement
Deadband Value - P	kW*	0.10 – 10000.00	0.01	10	Deadband value for the active power
Range Value - P	kW*	1.00 – 100000.00	0.01	500	Range value for the active power
Report Deadband - Q	-	Off, Amplitude, Integrated	-	Amplitude	Selection of the reporting mode for reactive power measurement
Deadband Value - Q	kVAr*	0.10 – 10000.00	0.01	10	Deadband value for the reactive power
Range Value - Q	kVAr*	1.00 – 100000.00	0.01	500	Range value for the reactive power
Report Deadband - S	-	Off, Amplitude, Integrated	-	Amplitude	Selection of the reporting mode for apparent power measurement
Deadband Value - S	kVA*	0.10 – 10000.00	0.01	10	Deadband value for the apparent power
Range Value - S	kVA*	1.00 – 100000.00	0.01	500	Range value for the apparent power
Report Deadband	Hz	Off, Amplitude, Integrated	-	Amplitude	Selection of the reporting mode for frequency measurement
Deadband Value	Hz	0.01 – 1.00	0.01	0.03	Deadband value for the frequency
Range Value	Hz	0.05 – 10.00	0.01	5	Range value for the frequency

**the prefixes can change (i.e. kW→MW, kV→V etc.) depending on the configuration; changing these is done by Protecta personnel*

***if the setting range is to be extended, contact Protecta personnel*

3.3.4.5.2. Function I/O

This section describes briefly the analogue and digital inputs and outputs of the function block.

3.3.4.5.2.1. Analogue inputs

The analogue inputs of the measurement functions are

- the Fourier components and true RMS values of the measured and calculated secondary voltages
- the Fourier components and true RMS values of the measured secondary currents,

3.3.4.5.2.2. Analogue outputs (measurements)

See the next chapter (On-line data) for the listing of all measurements. Note again, that the measured values depend on the type of the actual measurement function block, see Chapter [1.3.1](#)

3.3.4.5.2.3. On-line data

The **on-line data** of the line measurement function depend on the available analogue values which are referring to the applied hardware configuration.

Visible values on the on-line data page:

Table 2-2 On-line data of the line measurement function

SIGNAL TITLE	DIMENSION	EXPLANATION
Power - P	kW*	Calculated three-phase active power
Reactive Power - Q	kVAr*	Calculated three-phase reactive power
Apparent Power - S	kVA*	Calculated three-phase apparent power
Power factor	-	Calculated power factor
Current L1	A	Measured primary current L1 based on the nominal values of the CT4 current input function
Current L2	A	Measured primary current L2 based on the nominal values of the CT4 current input function
Current L3	A	Measured primary current L3 based on the nominal values of the CT4 current input function
Positive sequence current	A	Calculated positive sequence current from the three phase currents
Negative sequence current	A	Calculated negative sequence current from the three phase currents
Calculated 3I ₀	A	Calculated 3I ₀ from the three phase currents
Voltage L1	kV*	Measured primary L1 phase voltage L1 based on the nominal values of the VT4 voltage input function
Voltage L2	kV*	Measured primary L2 phase voltage L2 based on the nominal values of the VT4 voltage input function
Voltage L3	kV*	Measured primary L3 phase voltage L3 based on the nominal values of the VT4 voltage input function
Voltage L12	kV*	Calculated L12 phase-to-phase voltage
Voltage L23	kV*	Calculated L23 phase-to-phase voltage
Voltage L31	kV*	Calculated L31 phase-to-phase voltage
Positive sequence voltage	kV*	Calculated positive sequence voltage from the three phase voltages
Negative sequence voltage	kV*	Calculated negative sequence voltage from the three phase voltages
Calculated 3U ₀	kV*	Calculated 3U ₀ from the three phase voltages
Frequency	Hz	Measured frequency

**the prefixes may be different (i.e. kW→MW, kV→V etc.) depending on the configuration; changing these is done by Protecta personnel*

3.3.4.5.3. Technical data

Table 2-3 Technical data of the line measurement function (power)

POWER MEASUREMENT (P, Q, S)*	RANGE	ACCURACY
HW MODULES		
CT+/5115	0,002 – 0,01 In	±3%, ±1 digit
	0,01 – 0,03 In	±1%, ±1 digit
	0,03 – 5 In (max. 5 In for measurement purposes)	±0,5%, ±1 digit
CT+/1500**	0,002 – 0,005 In	±1,5%, ±1 digit
	0,005 – 0,02 In	±0,5%, ±1 digit
	0,02 – 2 In	±0,2%, ±1 digit
CT+/5151** CT+/5153 (Channel 1-3)	0,02 – 0,05 In	±3%, ±1 digit
	0,05 – 20 In	±0,5%, ±1 digit

* By using VT+/2211 with nominal voltage.

** The defined accuracy regarding the CT+/1500 and CT+/5151 modules are valid from 2020/Q2 or on customer request. For the values before this date, see [Table 2-7](#) in the next chapter.

Table 2-4 Technical data of the line measurement function (currents)

CURRENT MEASUREMENT (PHASE AND SEQUENTIAL)	RANGE	ACCURACY
HW MODULES		
CT+/5115	0,002 – 0,01 In	±3%, ±1 digit
	0,01 – 0,03 In	±1%, ±1 digit
	0,03 – 5 In (max. 5 In for measurement purposes)	±0,5%, ±1 digit
CT+/1500*	0,002 – 0,005 In	±1,5%, ±1 digit
	0,005 – 0,02 In	±0,5%, ±1 digit
	0,02 – 2 In	±0,2%, ±1 digit
CT+/5151* CT+/5153 (Channel 1-3)	0,02 – 0,05 In	±3%, ±1 digit
	0,05 – 20 In	±0,5%, ±1 digit

* The defined accuracy regarding the CT+/1500 and CT+/5151 modules are valid from 2020/Q2 or on customer request. For the values before this date, see [Table 2-7](#) in the next chapter.

Table 2-5 Technical data of the line measurement function (voltages)

VOLTAGE MEASUREMENT (PHASE, PHASE-TO-PHASE, SEQUENTIAL)	RANGE	ACCURACY
HW MODULES		
VT+/2211	0,05 – 1,5 Un	±0,5%, ±1 digit

Table 2-6 Technical data of the frequency measurement function

FREQUENCY MEASUREMENT	VALUE	ACCURACY
Frequency	40 - 60 Hz (50 Hz system) 50 - 70 Hz (60 Hz system)	± 2 mHz

3.3.4.5.3.1. Notes for testing

If there are no measurements seen on the SCADA software, check the Report Deadband parameter and/or the settings of the periodic reporting in the Communication Configurator. The former's default value is 'Off', and the latter's is 'False', which means that by default, the reporting is disabled. It must be enabled first.

The **periodic reporting** is defined in the device configuration file (.epc/.epcs) using EuroCAP. See Chapter [1.4.3](#). This also means that changing the properties of this will require loading a new configuration file to the device (hence a full device restart).



If the "Connection U1-3" parameter of the *VT4 module* function block is set to "Ph-Ph", the "ThreePhase"-method cannot be used for the power measurements here, so either of the "Aron" methods must be set for it. Otherwise, the device will provide a warning signal (yellow Status LED, "General param. error" message).

For the devices shipped with modules manufactured before 2020/Q2, the technical data table is different:

Table 2-7 Technical data of the line measurement function

HARDWARE MODULE	RANGE	ACCURACY
CT+/5151 or CT+/5102	0,2 In – 0,5 In	±2%, ±1 digit
	0,5 In – 20 In	±1%, ±1 digit
CT+/1500	0,03 In – 2 In	±0,5%, ±1 digit

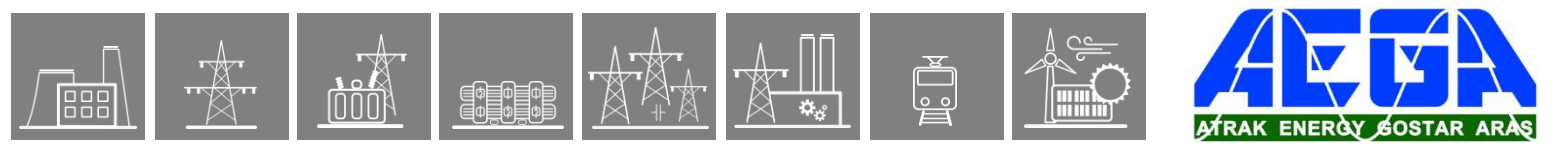

3.3.5. Average and maximum measurement function

3.3.5.1. The measurement

The input values of the EuroProt+ devices are the secondary signals of the voltage transformers and those of the current transformers.

These signals are pre-processed by the “Voltage transformer input” function block and by the “Current transformer input” function block. These function blocks are described in separate documents. The pre-processed values include the Fourier basic harmonic phasors of the voltages and currents and the true RMS values. Additionally, it is in these function blocks that parameters are set concerning the voltage ratio of the primary voltage transformers and current ratio of the current transformers.

Based on the pre-processed analog signals, several function blocks perform additional calculation, e.g.: active and reactive power, frequency, temperature, impedances, higher harmonics, symmetrical components, etc.

The “Average and maximum” function block calculates average values and locates maximum values of the assigned (measured and calculated) analog signals.

3.3.5.2. Operation of the function block

The **input** of the function can be:

- Any single calculated analog value: active and reactive power, frequency, temperature, impedances, higher harmonics, symmetrical components, etc. depending on the assignment in the configuration.

The **outputs** of the function are:

- Average of the analog value,
- Maximum of the analog value.

The average and the maximum values are automatically reported to the SCADA system. The maximum is logged and is sent automatically to the HMI, the average however is logged only if a binary input of the function block enables this activity.

3.3.5.3. Reporting the values

The average calculation needs a time span for calculation; this is given as a parameter value, set in minutes (or the function is switched off). When the timer expires, the calculated average is reported automatically to the SCADA system. Depending on the requirements, this value is also logged and is sent to the local HMI. This activity is controlled by a binary input of the function block.

The identification of the maximum value needs also a time span; this is given as a parameter value, set in days. When the timer expires, the found maximum value is reported automatically to the SCADA system. Additionally this value is also logged and is sent to the local HMI.

The starting of the timer is controlled by the internal real-time clock of the device. The moment of time for the starting of the processing cycles is set by a parameter value.

3.3.5.4. Parameters of the function block

Enumerated parameter

Parameter name	Title	Selection range	Default
Time window for averaging			
MXU_TimWin_EPar_T _	Average TimeWindow	Off,5min,10min,15min,30min,60min	Off

Table 1-1 The enumerated parameters of the average and maximum measurement function

Integer parameter

Parameter name	Title	Unit	Min	Max	Step	Default
Time window for finding the maximum value						
MXU_MaxResInt_IPar_T	MaxReset Interval	day	0	365	1	1
Moment of time for reporting and reset						
MXU_MaxResTime_IPar_T	MaxReset Time	hour	0	23	1	12

Table 1-2 The integer parameters of the average and maximum measurement function

3.3.5.5. Status signals of the function block

The average and maximum measurement function block has **binary input signals**, which serve the purpose of resetting the values and enabling logging the average value. **The conditions are defined by the user, applying the graphic equation editor.**

Binary status signal	Explanation
MXU_Reset_GrO_IL1 *	This signal resets both the calculated average and the found maximum value. At the end of the running cycles, the values found during the shortened cycle will be processed.
MXU_DemHMIEna_GrO_IL1	During the active state of this signal also the calculated average value is logged

* Note: In this example “IL1” is indicating that in the instant of the function block processes the RMS value of the current in line 1

Table 1-3 The binary input signal for the average and maximum measurement function block

The average and maximum measurement function block **has no binary output signals.**

3.3.5.6. The function block

The function block of the average and maximum measurement function is shown in Figure 1-1. This block shows all binary input (and output) status signals that are applicable in the graphic equation editor.

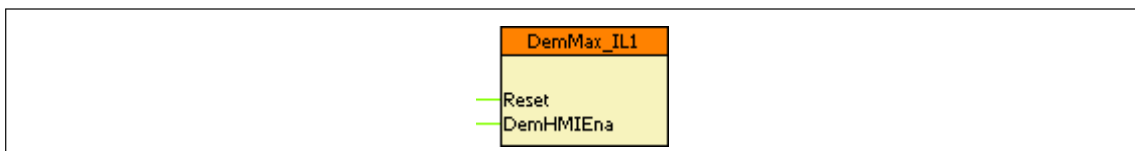
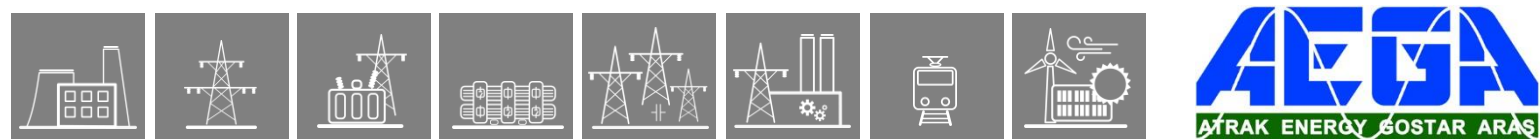

Figure 1-1 The function block of the average and maximum measurement function block



3.3.6.1.3. Impulse mode

Based on the external energy meter impulses. These impulse outputs of the meter connect as binary inputs. Metering function block calculates the active and reactive power supply and demand. These values are accumulated to obtain, separately:

- Active power demand,
- Active power supply,
- Reactive power demand.
- Reactive power supply,

Impulse scaling values are entered as parameters named “Active pulse scale” and “Reactive pulse scale”.

The time period of the accumulation is defined by parameter setting. It can be selected in a broad range. The start of the accumulation is based on the integrated real-time clock of the device. For example, for the “Time Interval” setting of 15min, the trigger is: at 0h0min, 0h15min, 0h30min, 0h45 min, 1h0min, etc.

When the accumulation time is over, the calculated values are reported to the SCADA system. The displayed values change continuously.

The calculated values are available as primary quantities and they can be displayed on the on-line screen of the device or on the webpage of the device and they are available for the SCADA system using the configured communication system

The **inputs** of the metering function are:

- the impulses of energy meter,
- parameters.

The **output** of the metering function is:

- displayed measured values.

3.3.6.1.4. Cumulation mode

“Cumulation mode” parameter defines the mode of operation. It can be “TRUE” or “FALSE”.

In “FALSE” mode the values set to zero after the values are reported to the SCADA system, based on the “Time Interval” settings.

In “TRUE” mode the values are cumulated after the report is sent to the SCADA system.

Maximum cumulated value depends on the CT module of IED and the primary nominals of CT and VT.

“Nominal primary power” = “Rated Primary U1-3” setting of VT module multiplied by “Rated Primary I1-3” setting of CT module. Unit prefix (kilo- or Mega) depends on the configuration, the “Line measurement” function uses the same unit prefix as Metering.

Maximum cumulated power value with CT+/1500 module = 3 259 602 multiplied by “Nominal primary power”

Maximum cumulated power value with CT+/5151 module = 65 192 055 multiplied by “Nominal primary power”

Maximum cumulated power value with CT+/5115 module = 8 149 006 multiplied by “Nominal primary power”

User can reset cumulated value to zero either by initiating the reset input of Metering function block or by restarting the device.

3.3.6.1.5. The measurement

3.3.6.1.5.1. Reference direction

“Reference direction” parameter setting defines the direction when voltage and current vectors are in phase. Setting can be “Demand” or “Supply”.

3.3.6.1.5.2. The measured values

Unit prefix of the **measured values** of the metering function depends on the configuration: it can be kilo or Mega. The “Line measurement” function uses the same unit prefix as the Metering.

MEASURED VALUE	EXPLANATION
MTR_PosP_OLM_	Demand kWh – active power consumption
MTR_NegP_OLM_	Supply kWh – active power supply
MTR_PosQ_OLM_	Demand kVArh – reactive power consumption
MTR_NegQ_OLM_	Supply kVArh – reactive power supply

Table 1-1 Measured values of the metering function

The measured values available are shown as on-line information, see the figure below.



Figure 1-1 Measured values of the metering function

3.3.6.1.6. Parameter setting

The time period of accumulation is defined by parameter setting. This can be selected in a broad range, as it is shown in Table 1-2.

Enumerated parameter

PARAMETER NAME	TITLE	SELECTION RANGE	DEFAULT
Selection of the time period for power metering			
MTR_TimInt_EPar_	Time Interval	Off, 5min, 10min, 15min, 30min, 60min	30min

Table 1-2 The enumerated parameter of the metering function

3.3.6.2. Metering function overview

The graphic appearance of the function block of the metering function is shown below. The block shows all binary input and output status signals which are applicable in the graphic equation editor.

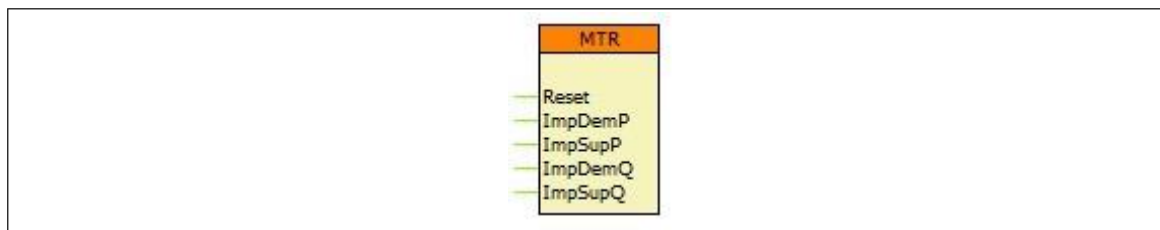

Figure 2-1 Graphic appearance of the function block of the metering function

3.3.6.2.1. Settings

3.3.6.2.1.1. Parameters

The available parameters are listed below in order of their appearance in the *parameters* menu. If the setting range of a parameter should be extended, contact Protecta Support.

Table 2-1 The available parameters of the metering function

TITLE	DIM.	RANGE	STEP	DEFAULT	EXPLANATION
Time Interval	-	Off, 5min (On), 10min , 15min , 30min , 60min	-	30min	Time period of accumulation parameter for general operation of the function:
Input selection	-	Measurement, Impulse,	-	Measurement	Input selection of energy calculation
Cumulation mode		FALSE,TRUE		FALSE	Cumulation mode is used
Reference direction	-	Demand, Supply	-	Demand	Energy direction reference selection.
Active pulse scale	kWh/ pulse	1 - 10000	1	100	One impulse of energy meter is equal to this setting
Reactive pulse scale	kVarh/ pulse	1 - 10000	1	100	One impulse of energy meter is equal to this setting

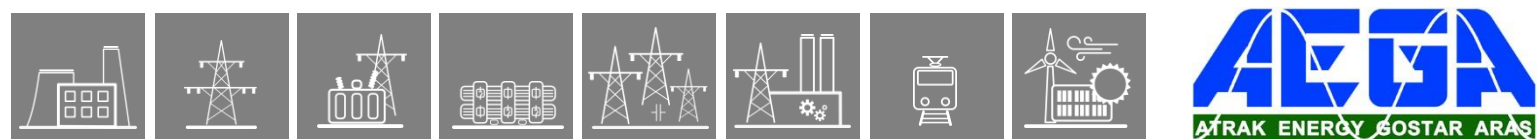

3.3.6.2.2. Function I/O

This section describes briefly the analogue and digital inputs and outputs of the function block.

3.3.6.2.2.1. Analogue inputs

The function uses the sampled values of a voltage and current inputs. This is defined in the configuration.

3.3.6.2.2.2. Analogue outputs (measurements)

The measured values of the metering function are listed in the table below.

Table 2-2 The measured analogue values of the metering function

MEASURED VALUE	DIMENSION	EXPLANATION
Demand P	kWh	<i>Demand P. Unit prefix can be kilo- or mega-, depends on the configuration</i>
Supply P	kWh	<i>Supply P. Unit prefix can be kilo- or mega-, depends on the configuration</i>
Demand Q	kVArh	<i>Demand Q. Unit prefix can be kilo- or mega-, depends on the configuration</i>
Supply Q	kVArh	<i>Supply Q. Unit prefix can be kilo- or mega-, depends on the configuration</i>

3.3.6.2.2.3. Binary input signals (graphed output statuses)

The conditions of the binary inputs are defined by the user, applying the graphic equation editor (*Logic Editor*). Parts written in **bold** are seen on the left side function block in the Logic editor.

Table 2-3 The binary input signal of the metering function

BINARY OUTPUT SIGNAL	EXPLANATION
MTR_Reset_GrO_	Reset input of the function has meaning only in cumulation mode
MTR_ImpDemP_GrO_	Demand P impulse of external energy meter input of the function has meaning only in impulse input mode
MTR_ImpSupP_GrO_	Supply P impulse of external energy meter input of the function has meaning only in impulse input mode
MTR_ImpDemQ_GrO_	Demand Q impulse of external energy meter input of the function has meaning only in impulse input mode
MTR_ImpSupQ_GrO_	Supply Q impulse of external energy meter input of the function has meaning only in impulse input mode

3.3.6.2.2.4. Events

The following events are generated in the event list, as well as sent to the SCADA according to the configuration.

Table 2-4 Generated events of the metering function

EVENT	DIMENSION	EXPLANATION
Demand P	Wh	<i>Demand P value</i>
Supply P	Wh	<i>Supply P value</i>
Demand Q	VArh	<i>Demand Q value</i>
Supply Q	VArh	<i>Supply Q value</i>

3.3.6.2.3. Technical data

Table 2-5 Technical data of the metering function

FUNCTION	RANGE	ACCURACY
Power accuracy	$I > 15\%I_n$	$\pm 3\%$

3.3.6.2.4. Notes for testing

Time period of the accumulation is defined by parameter setting.

Starting accumulation is based on the integrated real-time clock of the device.

For example, for a “Time Interval” setting of 15min, the trigger is: at 0h0min, 0h15min, 0h30min, 0h45 min, 1h0min, etc.

Parameter changing resets the accumulation. Using the settings of the example above, setting new parameters at 0h07min will result in the following:

- the accumulated values are reset to zero,
- the new accumulation starts at 0h15min,
- the first report is sent at 0h30min. Measured values in Events list will also refresh at 0h30min.

3.3.6.2.5. 61850 LN

Instance number of Logical Node is not mentioned in the table below.

Table 2-6 Logical Node and Data Objects of the metering function

LN NAME	DO NAME	DA NAME	FC	EXPLANATION
EMMTR	DmdVArhPV	mag.f	MX	<i>Demand VArh value</i>
		q	MX	<i>quality</i>
		t	MX	<i>timestamp</i>
	DmdWhPV	mag.f	MX	<i>Demand Wh value</i>
		q	MX	<i>quality</i>
		t	MX	<i>timestamp</i>
	SupVArhPV	mag.f	MX	<i>Supply VArh value</i>
		q	MX	<i>quality</i>
		t	MX	<i>timestamp</i>
	SupWhPV	mag.f	MX	<i>Supply Wh value</i>
		q	MX	<i>quality</i>
		t	MX	<i>timestamp</i>

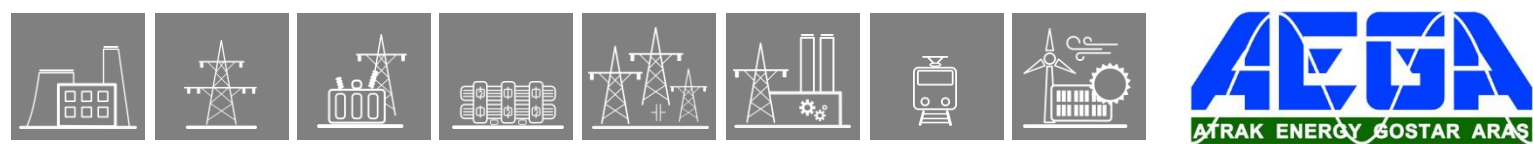

3.3.7. Voltage selection function block

3.3.7.1. Application

In several substation configurations with double busbar, there is no voltage measurement in the bays, but voltage transformers are connected to the busbars only.

If the protection functions configured in the bay devices apply voltage measurement then the correct selection of the voltage sources is needed. The role of the voltage selection is that the protection functions get the voltage of the busbar section to which the feeder or the transformer is connected.

To solve this problem the device gets both three-phase voltages of both busbar sections, and a binary signal decides which one is valid for the protection function.

The “Voltage selection” function block assigns the correct voltages to the protection functions.

3.3.7.2. Mode of operation

The voltage selection is decided by a binary signal. **The conditions are defined by the user applying the graphic equation editor.**

If this input signal is FALSE then the voltages of the voltage input module configured as default input are assigned to the protection functions.

If however this input signal is TRUE then the voltages of the other voltage input module are assigned to the protection functions.

3.3.7.3. The binary status signals

The voltage selection function block has a binary input signal. **The conditions are defined by the user applying the graphic equation editor.**

The **binary input status signal** of the voltage selection function block is shown in Table 1-1.

Binary status signal	Title	Explanation
SelectVolt_USelect_GrO_	USelect	Binary signal controlling the voltage selection

Table 1-1 The binary input status signal of the voltage selection function block

The **binary output status signals** of the voltage selection function block.

The voltage selection function block has no binary output status signals.

3.3.7.4. The parameters

The voltage selection function block has no parameters.

3.3.7.5. The symbol of the function block in the graphic editor

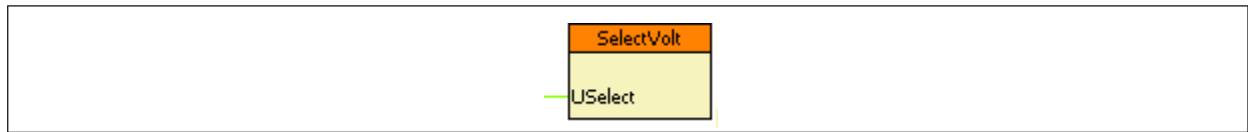

Figure 1-1 The function block of the voltage selection function block

The name of the input signal is a part of the “Binary status signal” name shown in Table 1-1.

3.3.7.6. Example

In this simple example the channel No.1 of the binary input module in position “F” is used as the signal controlling the selection.

If this input signal is FALSE then the voltages of the voltage input module configured as default input are assigned to the protection functions.

If however this input signal is TRUE then the voltages of the other voltage input module are assigned to the protection functions.



Figure 2-1 Example The simple application of the voltage selection function block

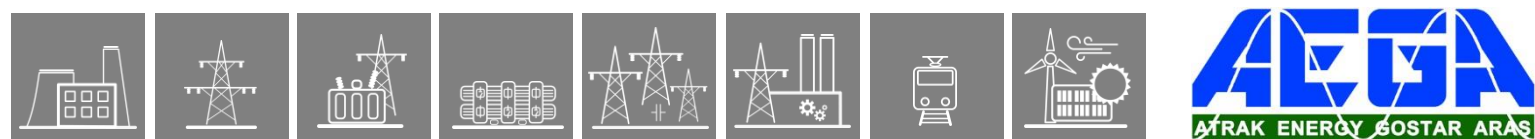

3.3.8. Trip Value Recorder

3.3.8.1. Application

For quick evaluating of network faults, it is very useful to see in the event list of the protection device the measured primary analog values (currents, voltages) before and during the fault state. The Trip value recorder function serves this purpose.

This function is not a default element of any configuration, but it can be acquired (please contact Protecta Support team).

3.3.8.1.1. The measurement

The input values of the EuroProt+ devices are the secondary signals of the voltage transformers and those of the current transformers.

These signals are pre-processed by the "Voltage transformer input" function block and by the "Current transformer input" function block. These function blocks are described in separate documents. The pre-processed values include the Fourier basic harmonic phasors of the voltages and currents and the true RMS values. Additionally, it is in these function blocks that parameters are set concerning the voltage ratio of the primary voltage transformers and current ratio of the current transformers.

Based on the pre-processed analogue signals, several function blocks perform additional calculation, e.g.: active and reactive power, frequency, temperature, impedances, higher harmonics, symmetrical components, etc.

The Trip value recorder function calculates the primary values from its three input secondary signals (currents or voltages) and uses them as described in the following chapter.

3.3.8.1.2. Operation principles

The Trip value recorder has two binary inputs: "Start" and "Trip".

When the "Start" binary input receives a rising edge signal, the function stores the prefault value of the three analogue signals and the fault value of the three analogue signal as well and the function starts waiting for the trigger (Trip) signal. If no trigger signal coming and new start signal receives the stored prefault and fault values will be overwritten by the latest ones.

The "Trip" binary input of the function is applied for triggering the trip value recording to generate the events with the prefault and fault values.

After triggering the function, so the "Trip" binary input is activated, the function generates the following values in the event list and sends them automatically to the SCADA system:

- prefault values of the three analog signals 100 ms before the Start signal receives,
- fault values of the three analog signals: average of the values 10 ms and 20 ms after the Start.

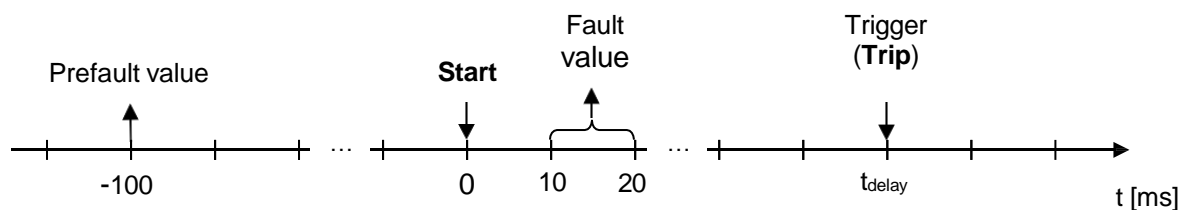

Figure 1-1 Time diagram of the trip recording behaviour

3.3.8.2. Trip value recorder function overview

The graphic appearance of the function block of the trip value recorder function is shown below. The block shows all binary input and output status signals which are applicable in the graphic equation editor.

Usually, the collected general start signal of the protection functions is assigned to the “Start” input and the general trip signal of trip logic function is connected to the “Trip” input.

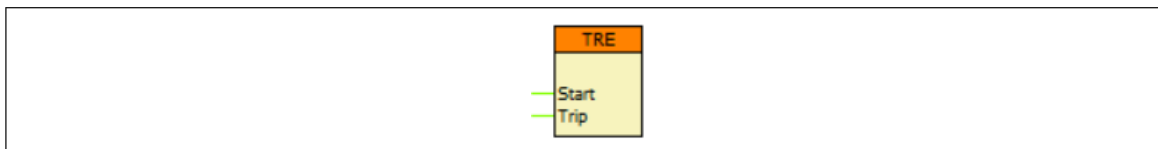

Figure 2-1 Graphic appearance of the function block of the trip value recorder function

3.3.8.2.1. Settings

3.3.8.2.1.1. Parameters

The Trip value recorder function does not have any parameters.

3.3.8.2.2. Function I/O

This section describes briefly the analogue and digital inputs and outputs of the function block.

3.3.8.2.2.1. Analogue inputs

The function uses the sampled values of a current input or voltage input. Moreover, calculated analogue signals i.e.: symmetrical values, differential/bias current values can be used as inputs.

The following table contains the available input channels of the trip value recorder function.

Table 2-1 Available analogue inputs of the trip value recorder function

ANALOGUE INPUTS	RELATED FUNCTION BLOCK
Phase current, phase-to-phase, symmetrical, residual currents	CT4, CalcCurr
Voltage in phase, phase-to-phase, and symmetrical; Reference (busbar) voltages	VT4, CalcVolt
Calculated Idiff/Ibias current of transformer differential protection	DIF87T
Calculated Idiff/Ibias current of busbar differential protection for each bus section	DIF87B

NOTE: Displaying the fault current values of the line differential protection Idiff/Ibias current and the restricted earth fault protection Idiff/Ibias current are integrated into the protection function, thus not need additional trip value functions to display the trip values.

3.3.8.2.2.2. Binary input signals (graphed output statuses)

The conditions of the binary inputs are defined by the user, applying the graphic equation editor (*Logic Editor*). Parts written in **bold** are seen on the left side function block in the Logic editor.

Table 2-2 The binary input signal of the trip value recorder function

BINARY OUTPUT SIGNAL	EXPLANATION
TRE_Start_GrO_	Dedicated input of the function to receive the start signal of the selected protection functions
TRE_Trip_GrO_	Dedicated input of the function to receive the trip signal of the selected protection functions



3.3.8.2.2.3. Binary output signals (graphed input statuses)

The Trip value recorder function does not have any binary output signals.

3.3.8.2.2.4. Online data

No default visible values on the *online data* page.

3.3.8.2.2.5. Events

The following events are generated in the event list, as well as sent to the SCADA according to the configuration.

Table 2-3 Generated events of the trip value recorder function

EVENT	VALUE	EXPLANATION
... Prefault*	according to the applied input	Prefault value of the applied signal
... Fault*	according to the applied input	Fault value of the applied signal

**The event text may vary according to the actual device configuration (.epcs)*

3.3.9. RTD temperature input function

3.3.9.1. Application of the RTD input

If the factory configuration includes an RTD temperature input hardware module, the temperature input function block is automatically configured among the software function blocks. Separate temperature input function blocks are assigned to each temperature input hardware module.

The RTD+1100 temperature input hardware module is equipped with four special input channels, the RTD+ 0200 has a single channel only. (See EuroProt+ hardware description document.) To each channel, a temperature sensor can be connected. The temperature is measured as the resistance value of the sensor, which depends upon the temperature.

The sensors can be connected by wiring methods, shown in Figure 1–1, Figure 1–2 and Figure 1–3. The connection mode is identified also by parameter setting.

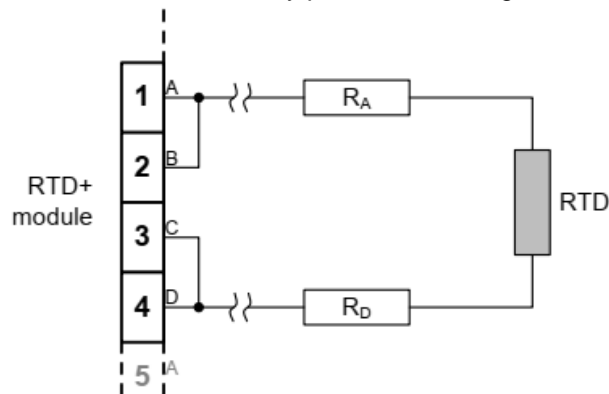

Figure 1–1 2-wire RTD wiring

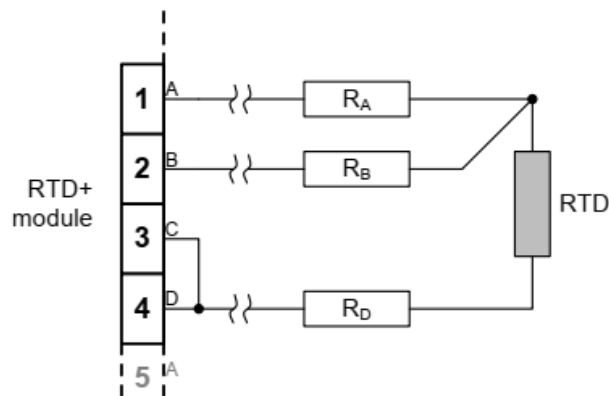

Figure 1–2 3-wire RTD wiring

When 3-wire connection is applied, it is supposed that $R_A=R_D$.

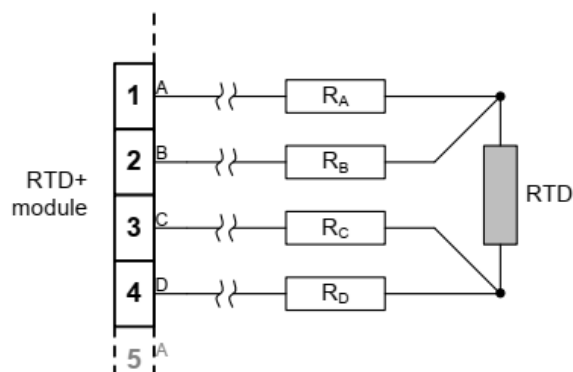
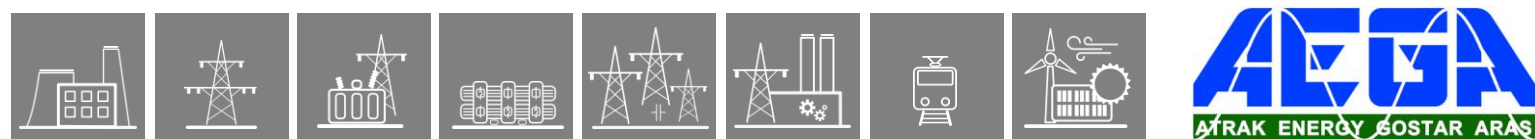
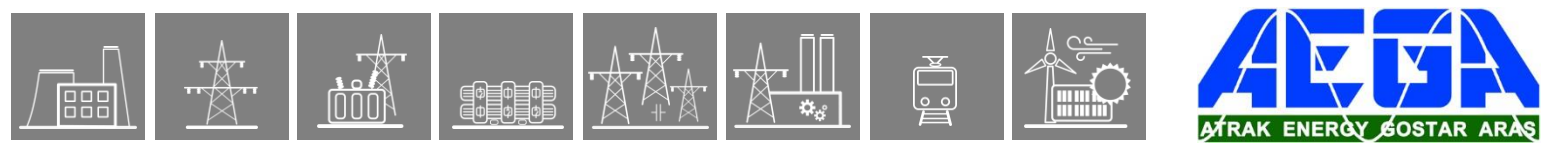

Figure 1-3 4-wire RTD wiring

The channels of the module are independent of each other. To each channel a dedicated measuring module is assigned. These measuring modules are described in a separate document: “**GGIORTD temperature measurement module function block description**”. The module is prepared to connect the following types of sensors:

- Pt100/Ni100
- Ni120/Ni120US
- Pt250/Ni250
- Pt1000/Ni1000
- Cu10
- Service-Ohm (60 Ω ... 1.6 k Ω)

The applied type of sensors define the conversion mode from measured resistance to temperature. These are selected by parameters of the temperature measuring module. See separate document: “**GGIORTD temperature measurement module function block description**”.



3.3.9.2. Technical summary

3.3.9.2.1. Technical data

The technical data of the temperature input module are related to the hardware module. This is described in the document “**EuroProt+ Hardware description**, Chapter 10: RTD input module”.

3.3.9.2.2. Summary of the parameters

The parameters of the temperature input function are explained in the following table.

Enumerated parameters

Parameter name	Title	Selection range	Default
Connection mode of Channel 1			
RTD_Ch1RangeOfMAn03_EPar_	Channel 01	3wire, 4wire, 2wire	3wire
Connection mode of Channel 2			
RTD_Ch2Range2OfMAn03_EPar_	Channel 02	3wire, 4wire, 2wire	3wire
Connection mode of Channel 3			
RTD_Ch3RangeOfMAn04_EPar_	Channel 03	3wire, 4wire, 2wire	3wire
Connection mode of Channel 4			
RTD_Ch4Range2OfMAn04_EPar_	Channel 04	3wire, 4wire, 2wire	3wire

Table 1-1 The enumerated parameters of the voltage input function

NOTE: The function block has no input and output binary signals, the graphic logic editor does not show this function block.

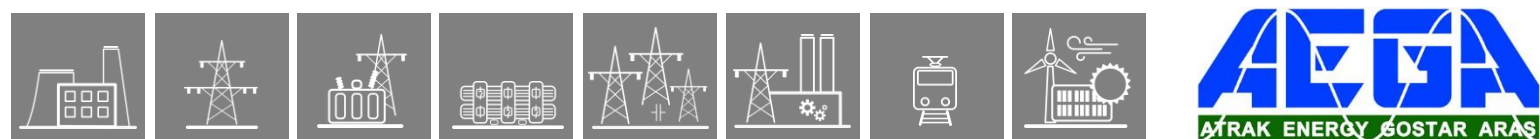

3.4. Disturbance recorder function

The disturbance recorder function can record analog signals and binary status signals. These signals are configured using the EuroCAP software tool.

The disturbance recorder function has a binary input signal, which serves the purpose of starting the function. **The conditions of starting are defined by the user, applying the graphic equation editor.** The disturbance recorder function keeps on recording during the active state of this signal but the total recording time is limited by the timer parameter setting.

The pre-fault time, max recording time and post-fault time can be defined by parameters.

3.4.1. Mode of recording

If the triggering conditions defined by the user - using the graphic equation editor – are satisfied and the function is enabled by parameter setting, then the disturbance recorder starts recording the sampled values of configured analog signals and binary signals.

The analog signals can be sampled values (voltages and currents) received via input modules or they can be calculated analog values (such as negative sequence components, etc.)

The number of the configured binary signals for recording is limited to 64, and up to 32 analog channels can be recorded.

The available memory for disturbance records is 12 MB.

There are two function blocks available. The first function (**DRE**) applies 20 sampling in a network period. Accordingly for 50 Hz, the sampling frequency is 1 kHz. (For 60 Hz the sampling frequency is 1.2 kHz). This is used in all configurations by default.

The second function (**DRE2**) is capable to be set by parameter to apply 20 or 40 sampling in a network period. This way accordingly for 50 Hz, the sampling frequency is 1 kHz or 2 kHz (and for 60 Hz the sampling frequency is 1.2 kHz or 2.4 kHz). *Except for this, the two function blocks are the same.*

As an example, for 50 Hz, if the duration of the record is 1000 ms then one analog channel needs about 7 kB and a binary channel needs 2 kB, Using the following formula the memory size can be estimated:

$$\text{Memory size of a record} = (n \cdot 7 \text{ kB} + m \cdot 2 \text{ kB}) \cdot \text{record duration (s)}$$

Here n,m: are the number of analog and binary channels respectively.

During the operation of the function, the pre-fault signals are preserved for the time duration as defined by the parameter “PreFault”.

The recording duration is limited by the parameter “Max Recording Time” but if the triggering signal resets earlier, this section is shorter.

The post-fault signals are preserved for the time duration as defined by the parameter “PostFault”.

During or after the running of the recording, the triggering condition must be reset for a new recording procedure to start.

3.4.2. Format of recording

The records are stored in standard COMTRADE format.

- The configuration is defined by the file .cfg,
- The data are stored in the file .dat,
- Plain text comments can be written in the file .inf.

3.4.3. Downloading and evaluating the disturbance records

The procedure for downloading the records is described in detail in the EuroProt+ manual “Remote user interface description”, Chapter 4.7. The three files are zipped in a file .zip. This procedure assures that the three component files (.cfg, .dat and .inf) are stored in the same location.

The evaluation can be performed using any COMTRADE evaluator software. Protecta offers the “srEval” software for this purpose. The application of this software is described in detail in the “srEval manual”. This manual can be downloaded from the following Internet address: http://www.softreal.hu/product/sreval_en.shtml.

3.4.4. Parameters of the disturbance recorder functions

Enumerated parameters

Parameter name	Title	Selection range	Default
Parameter for activation			
DRE_Oper_EPar_	Operation	Off, On	Off
DRE_Resolution_EPar_	Resolution *	1/1.2kHz, 2/2.4kHz	1/1.2kHz

*only on the optional 2/2.4 kHz disturbance recorder function

Table 1-1 The enumerated parameters of the disturbance recorder functions

Timer parameters

Parameter name	Title	Unit	Min	Max	Step	Default
Pre-fault time:						
DRE_PreFault_TPar_	PreFault	msec	100	1000	1	200
Post-fault time:						
DRE_PostFault_TPar_	PostFault	msec	100	1000	1	200
Overall-fault time limit:						
DRE_MaxFault_TPar_	Max Recording Time	msec	500	10000	1	1000

Table 1-2 The timer parameters of the disturbance recorder functions

NOTE: The device goes automatically in “Warning” state and sends a warning message (see [Figure 1-1](#)) if the sum of the pre-fault time and post-fault time is longer than the overall-fault time. The corresponding message in the RDSP log file is: „Wrong DR settings. PreFault + PostFault must be less than MaxFault. Check the parameters.”

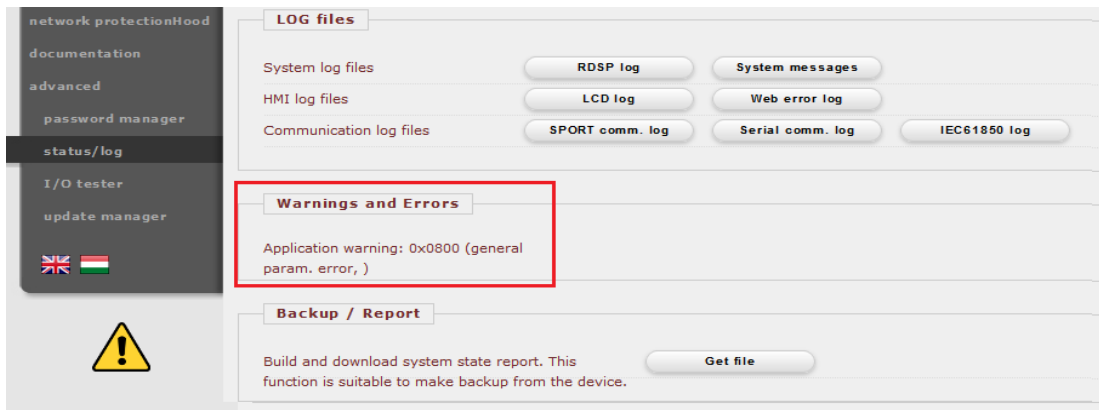

Figure 1-1 Warning message if the settings are invalid

3.4.5. The input signals of the disturbance recorder functions

Binary status signals

The disturbance recorder function has a binary input signal, which serves the purpose of starting the function. **The conditions of starting are defined by the user, applying the graphic equation editor.**

Binary status signal	Explanation
DRE_Start_GrO_	Output status of a graphic equation defined by the user to start the disturbance recorder function.

Table 1-3 The binary input signal of the disturbance recorder functions

The recording is performed if the function is enabled by the parameter setting AND the triggering condition as defined by the user is “True” as well.

3.4.6. The function blocks

The two function blocks of the disturbance recorder function is shown in [Figure 1-2](#). The block shows the binary input status signal, which serves the purpose of triggering the record. It is defined by the user in the graphic equation editor.

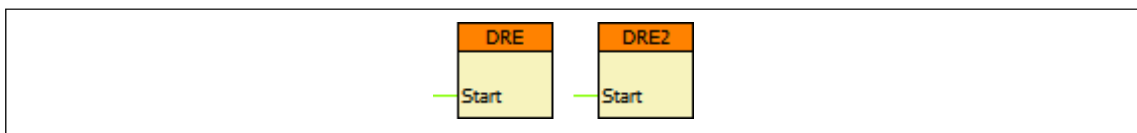
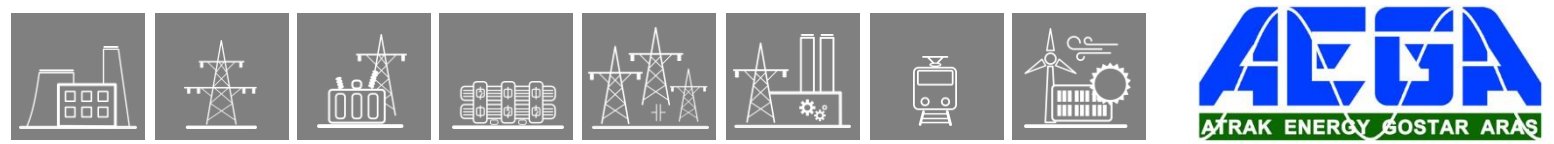

Figure 1-2 The function blocks of the disturbance recorder functions

3.4.7. The recorded signals

The analog and binary signals to be recorded are configured using the EuroCAP software tool in the menu item “Software configuration/Disturbance recorder”. (The access level of the user must be at least “Master”.) The application of this software is described in detail in the EuroCAP manual.



3.5. Event recorder

The events of the device and those of the protection functions are recorded with a time stamp of 1 ms time resolution. This information with indication of the generating function can be checked on the touch-screen of the device in the “Events” page, or using an Internet browser of a connected computer

4. Maintenance guide for EuroProt+ devices

4.1. Foreword

The EuroProt+ devices are designed with the most up-to-date and durable components available, to keep appliances in continuous operation for decades. For this range, the only type of components that can age and lead to equipment failure are the power supply capacitors. Therefore, this document, in addition to suggesting some general steps for planned inspections, contains important information on the inspection of power supply modules.

4.2. Safety precautions

The EP+ protection-family, depending on the type, operates at dangerous power supply voltages (220 VDC, 230 VAC, 60 VDC, 48 VDC).



In all cases where the connections of the appliance are to be installed or opened, the work must be carried out by a suitably qualified person.

In all cases, the first step of activity should be to switch off the power



The EuroProt+ protection family has a high operating internal temperature. Operations carried out immediately after operation may lead to dangerous burns.



The hardware and software of the EP+ protection family form a complex system. Setting, modifying, and mounting the individual components may severely affect the operation of the whole system.

In all cases where the device is to be operated or maintained, the activity must be carried out by qualified personnel only

4.2.1. General guidelines for a scheduled maintenance of EP+ devices

1. As a first step, it is recommended to send an email attaching a report.zip file to the Protecta Application Department on the email address application@protecta.hu. In the report file, the logs contain information that can indicate abnormal operation of a module before it causes an operational fault. Based on this information, Protecta can make recommendations for the replacement or repair of the modules concerned.



The report.zip file can be downloaded from the device's web interface, in the Backup / Report section of the Advanced / Status / Log menu, by pressing the "Get file" button. Attention! The file size should be about 700kB. If the downloaded file size is significantly smaller than this, please try again or contact Protecta's Application Department via our web-based support system (<https://support.protecta.hu/?language=English>)!

2. It is usually recommended to update the firmware of the devices during scheduled maintenance. Information about the new firmware releases can be found in the [Release Notes on the Protecta homepage](#). The information here can be used to consider upgrading the basic software for a single device, or all devices in a substation.



Before starting the upgrade, always contact the Protecta Application Department or submit a ticket in the web-based support system from the following link: <https://support.protecta.hu/>

For more details on the firmware update, please refer to Chapter 4.2.10.4 of the [EuroProt+ Operating Manual](#).

4.3. Power supply maintenance

Power supplies are designed with the longest possible life electrolytic capacitors. Their expected lifetime depends significantly on the environmental conditions of the device. During a scheduled inspection, we recommend visual inspection of the power supply for any abnormalities in the capacitors. The most common phenomena are: bloating, electrolyte leakage, discoloration, which typically occurs on capacitors, but can also occur on the surface of the PCB board due to leakage. In case of abnormality, the capacitors should be replaced. In such a case, please contact Protecta's Application Department via our support page (<https://support.protecta.hu/>)!

The following figures illustrate the different capacitor states in several photos.



Figure 4-1 The capacitor on the right is already discolored

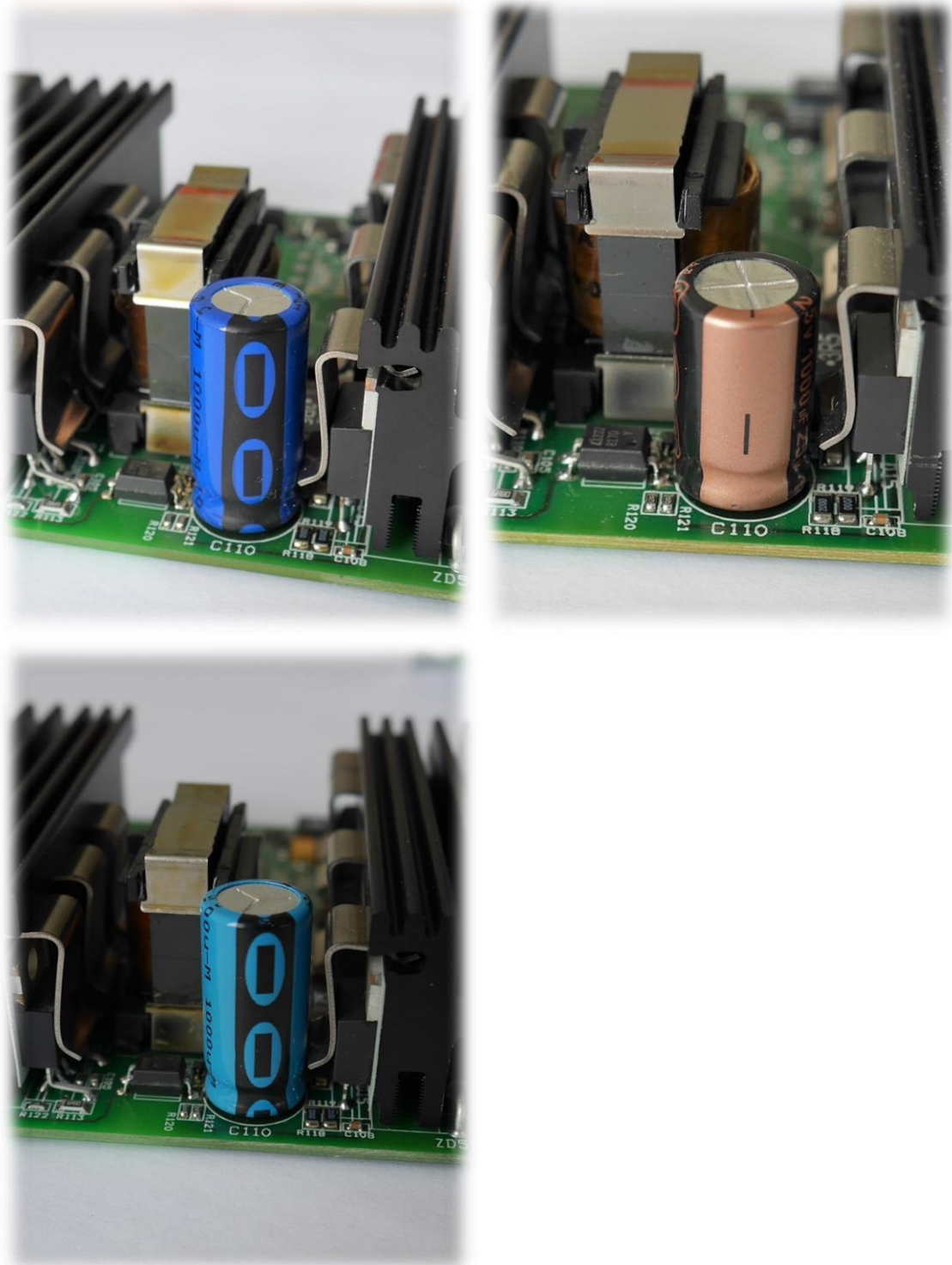

Figure 4-2 Healthy capacitors on visual inspection



Figure 4-3 Faulty capacitances on visual inspection. The discoloration compared to the original blue color is clearly visible, bloating can be seen on 2 of them

4.4. Elements and Batteries

Az EuroProt+ protection family devices do not contain either a single-use battery or a rechargeable battery.

5. External connections

