

Manual

Transmission line protection & control
EuroProt+/DTVA

E2-LINE

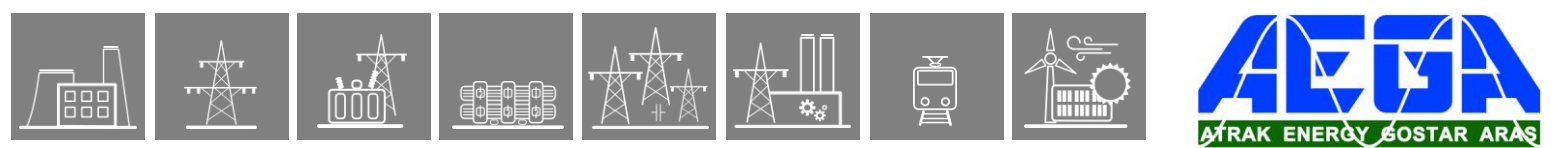

VERSION INFORMATION

NAME	DOCUMENT ID	VERSION	DATE
EuroProt+ DTVA type	PP-13-21884	1.1	2020-06-09
EuroProt+ Hardware description	PP-13-19958	2.0	2023-02-10
Distance protection function	PP-13-22004	2.0	2019-12-20
Distance protection with MHO characteristics function	VERSION 1.1	1.1	2021-04-23
Switch-onto-fault preparation function	VERSION 1.0	1.0	2012-02-29
Synchro check synchro switch function	VERSION 1.0	1.0	2011-06-27
Definite time undervoltage protection function	PP-13-21403	1.1	2017-01-11
Directional overpower protection function	PP-13-22276	2.0	2021-01-06
Directional underpower protection function	PP-13-22277	2.0	2021-01-06
Negative sequence overcurrent protection	PP-13-20319	1.3	2022-08-09
Broken conductor protection	PP-13-22162	1.1	2020-06-29
Negative sequence definite time overvoltage protection function	PP-13-20580	1.0	2014-08-26
Line thermal protection	VERSION 1.0	1.0	2011-10-25
Three-phase Instantaneous Overcurrent Protection	PP-13-22489	2.0	2022-03-04
Residual Instantaneous Overcurrent Protection	PP-13-22488	2.1	2022-11-28
Breaker failure protection	PP-13- 22253	2.1	2022-10-03
Three-phase overcurrent protection	PP-13-21408	2.4	2022-08-22
Residual overcurrent protection	PP-13-20320	1.3	2022-08-22
Definite time overvoltage protection function	PP-13-21400	1.2	2017-01-11
Residual definite time overvoltage protection function	VERSION 1.0	1.0	2011-06-27
Directional three-phase overcurrent protection function	PP-13-20321	2.1	2022-08-22
Directional residual time overcurrent protection function	PP-13-20322	1.3	2022-08-22
Inrush current detection function	PP-13-22394	2.0	2021-08-10
Automatic reclosing function for high voltage networks	PP-13-21370	1.2	2017-02-08
Overfrequency protection function	PP-13-21379	2.2	2021-07-30
Underfrequency protection function	PP-13-21379	2.2	2021-07-30
Rate of change of frequency function	PP-13-21385	2.1	2020-02-11
Line differential protection function	PP-13-22045	2.0	2020-02-07
Teleprotection function	PP-13-22409	2.0	2021-09-15
Weak end infeed logic function	PP-13-20268	1.0	2014-01-29
Pole slipping protection function	PP-13-22519	2.1	2022-03-08
Stub protection function	PP-13-22517	2.0	2022-03-04
Phase-Selective Trip Logic	PP-13-21531	2.0	2019-03-12
Circuit breaker wear monitoring	PP-13-21310	1.1	2016-09-06
Circuit Breaker control	PP-13-21877	2.0	2019-04-01
Disconnecter control	PP-13-20396	2.0	2019-04-01
Ethernet Links function	PP-13-21870	1.0	2019-02-19
Trip Circuit Supervision (TCS)	PP-13-21875	1.2	2019-08-09
Application of high-speed TRIP contacts	PP-13-21592	1.1	2017-10-02
Dead Line Detection Function	PP-13-22522	2.0	2022-03-04
Voltage transformer supervision and dead line detection	VERSION 1.1	1.1	2011-10-25
Current unbalance function	PP-13-22163	2.0	2020-06-25
Current input function block setting guide	VERSION 1.1	1.0	2015-01-29
Voltage input function block setting guide	VERSION 1.0	1.0	2015-01-29

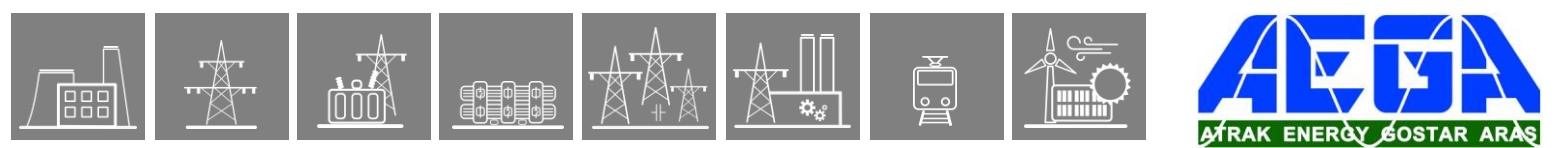

Line measurement Frequency measurement Voltage measurement Current measurement	PP-13-21168	2.3	2021-09-02
Disturbance recorder	PP-13-20368	3.0	2017-06-02
Average and maximum measurement function	PP-11-20109	1.0	2013-09-27
Metering function	PP-13-22238	2.1	2022-10-19
Trip value recorder function	PP-13-20947	2.1	2020-12-10
Voltage measurement selection function	VERSION 1.0	1.0	2013-02-06
Earth-fault phase selection function	VERSION 1.0	1.0	2015-06-05
Setting guide to the directional overcurrent protection	-	1.0	2014-10-21
Automatic reclosing function for high voltage networks setting guide	PP-13-21370	1.2	2017-02-08
Distance protection function setting guide	VERSION 1.1	1.0	2015-06-12
Line differential communication application guide	PP-13-20511	2.0	2023-08-31
Charging current compensation in line differential protection function	PP-11-20335	1.0	2014-02-28
AIC current input function	PP-13-21392	1.0	2017-01-03
Remote I/O (RIO) server description	PP-13-22346	1.0	2021-06-02
Technical notes on EOB interoperability	-	1.0	2011-06-27
Maintenance guide	PP-13-226045	2.0	2022-11-18
RTD temperature input function	PP-13-21394	1.0	2017-01-03
EP+ Installation manual	PP-06-22516	1.0	2022-03-09

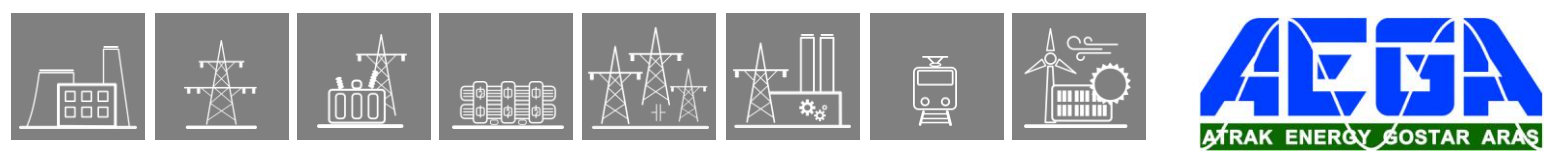
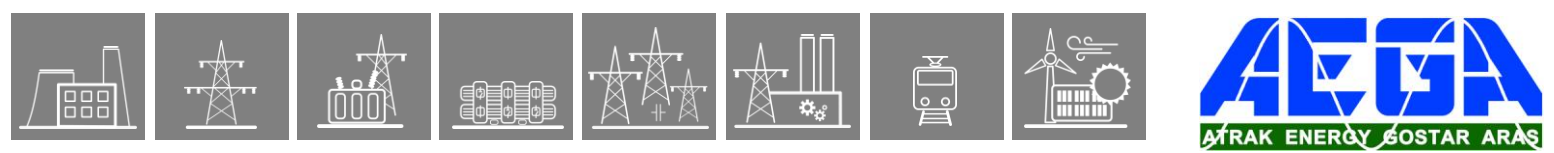
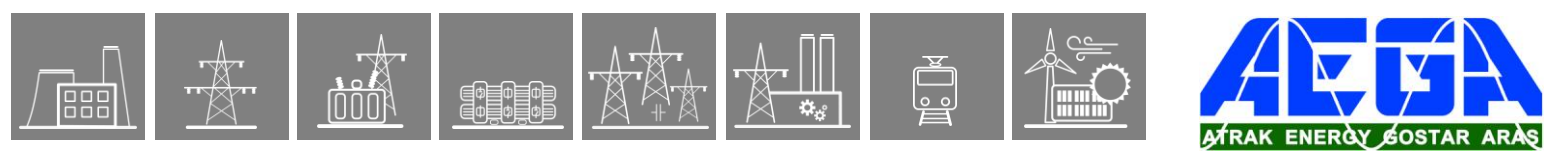

Table of Contents

1. Introduction	7
1.1. Application.....	7
1.1.1. General features	7
1.2. Pre-defined configuration variants	8
1.3. Hardware configuration	9
1.3.1. The applied hardware modules	11
1.3.2. Meeting the device	12
1.3.3. System design.....	13
1.3.4. CPU and COM module	14
1.3.5. Device housings	34
1.3.6. Human-Machine Interface (HMI) module	36
1.3.7. Current input module	43
1.3.8. Voltage input module	48
1.3.9. Binary input module.....	50
1.3.10. Signaling module	53
1.3.11. Tripping module.....	56
1.3.12. RTD input module.....	77
1.3.13. Analog input module (AI)	79
1.3.14. Analog output module (ATO)	81
1.3.15. Sensor input module.....	83
1.3.16. INJ module.....	85
1.3.17. Generator protection modules	86
1.3.18. Power supply module	89
1.3.19. Sampling synchronization module	93
1.3.20. Mixed function modules	94
1.3.21. General data.....	104
1.3.22. Mechanical data.....	106
1.3.23. Mounting methods.....	109
1.3.24. Product availability (special and obsolete modules)	129
1.3.25. Remote I/O (RIO) server description.....	134
1.3.26. Technical notes on EOB interoperability.....	143
1.3.27. EP+ Installation manual	146
2. Function and I/O listing.....	154
3. Line differential communication application guide.....	156
3.1. Introduction.....	156
3.1.1. Setting of the VLAN parameters	156
3.2. Peer-to-peer communication	157
3.2.1. Direct link.....	157
3.2.2. Via LAN/Telecom network.....	158
3.3. Pilot wire application	159
3.4. Line differential communication via telecom networks	161
3.4.1. Communication via G.703 64kbit/s co-directional interface (E0).....	161
3.4.2. Communication via 2.048Mbit/s (E1/T1) Nx64kbit/s interface	162
3.5. Redundant line differential communication.....	163
3.5.1. G.703 and 100Base-FX redundancy.....	163



3.5.2.	100Base-FX redundancy	164
3.6.	Three terminal line differential communication	165
3.7.	2-ends line differential communication with three terminals	167
3.7.1.	Variant 1	167
3.7.2.	Variant 2	169
3.7.3.	Variant 3	170
3.8.	Remote binary signal transmission	172
3.8.1.	Direct link communication	172
3.8.2.	Three or more terminals binary signal transmission	173
3.9.	Communication interface characteristics	176
3.9.1.	Ethernet multi-mode transmitter and receiver	176
3.9.2.	Ethernet single mode transmitter and receiver	177
3.9.3.	G.703 64kbit/s co-directional interface (E0)	178
3.9.4.	2.048Mbit/s (E1/T1) Nx64kbit/s interface	179
4.	Software configuration	180
4.1.	Protection functions	180
4.1.1.	Distance protection function	182
4.1.2.	Distance protection function with MHO haracteristics	229
4.1.3.	Switch-onto-fault preparation function	276
4.1.4.	Synchro check / synchro switch function	279
4.1.5.	Definite time undervoltage protection function	295
4.1.6.	Directional over-power protection function	303
4.1.7.	Directional under-power protection function	309
4.1.8.	Negative sequence overcurrent protection function	315
4.1.9.	Broken conductor protection	326
4.1.10.	Negative sequence definite time overvoltage protection function	334
4.1.11.	Line thermal protection function	341
4.1.12.	Three-phase instantaneous Overcurrent Protection	354
4.1.13.	Residual Instantaneous Overcurrent Protection	363
4.1.14.	Breaker failure protection	372
4.1.15.	Three-phase time overcurrent protection	381
4.1.16.	Residual overcurrent protection function	397
4.1.17.	Definite time overvoltage protection function	406
4.1.18.	Residual definite time overvoltage protection function	415
4.1.19.	Directional three-phase overcurrent protection function	422
4.1.20.	Directional residual overcurrent protection function	447
4.1.21.	Inrush current detection function	462
4.1.22.	HV AutoReclosing	467
4.1.23.	Over-frequency protection function	484
4.1.24.	Underfrequency protection function	488
4.1.25.	Rate of change of frequency protection function	492
4.1.26.	Teleprotection	496
4.1.27.	Line Dif-ferential protection	513
4.1.28.	Weak end infeed logic	529
4.1.29.	Out of Step (Pole slipping) protection function	534
4.1.30.	Stub protection function	536
4.1.31.	Charging current compensation in line differential protection	541
4.2.	Control & supervision functions	545
4.2.1.	Phase-Selective Trip Logic	545
4.2.2.	Circuit breaker wear monitoring function	549



4.2.3.	Circuit breaker control function block.....	554
4.2.4.	Disconnecter control function.....	560
4.2.5.	Ethernet Links function.....	567
4.2.6.	Trip Circuit Supervision	570
4.2.7.	Dead Line Detection Function	577
4.2.8.	Voltage transformer supervision function.....	586
4.2.9.	Current unbalance function.....	601
4.2.10.	Earth-fault phase selection function	607
4.3.	Measuring functions	610
4.3.1.	Current input function	612
4.3.2.	AIC current input function.....	617
4.3.3.	Voltage input function	619
4.3.4.	Line and frequency measurement functions	627
4.3.5.	Average and maximum measurement function.....	637
4.3.6.	Metering	639
4.3.7.	Voltage selection function block.....	645
4.3.8.	Trip Value Recorder	647
4.3.9.	RTD temperature input function.....	650
4.4.	Disturbance recorder function	653
4.4.1.	Mode of recording.....	653
4.4.2.	Format of recording.....	654
4.4.3.	Downloading and evaluating the disturbance records	654
4.4.4.	Parameters of the disturbance recorder functions.....	654
4.4.5.	The input signals of the disturbance recorder functions	655
4.4.6.	The function blocks	655
4.4.7.	The recorded signals.....	655
4.5.	Event recorder	656
4.6.	Setting of distance protection function	657
4.6.1.	Setting the polygon characteristics	657
4.6.2.	Binary signals influencing of the distance protection function.....	673
4.6.3.	The current conditions of the distance protection function	677
4.6.4.	The embedded function block for power swing detection (PSD)	679
4.6.5.	The distance-to-fault calculation (FAULT LOCATOR).....	683
4.6.6.	The high-speed overcurrent protection function with switch-onto-fault logic (HSOC SOTF)	684
4.6.7.	Setting in some special applications.....	685
4.6.8.	Appendix: Compensation of the distance distortion due to the power transfer and the fault resistance	687
5.	Maintenance guide for EuroProt+ devices	697
5.1.	Foreword	697
5.2.	Safety precautions	697
5.2.1.	General guidelines for a scheduled maintenance of EP+ devices	698
5.3.	Power supply maintenance.....	699
5.4.	Elements and Batteries	701
6.	TRIP contact assignment.....	702
7.	LED assignment	704
8.	External connection	705

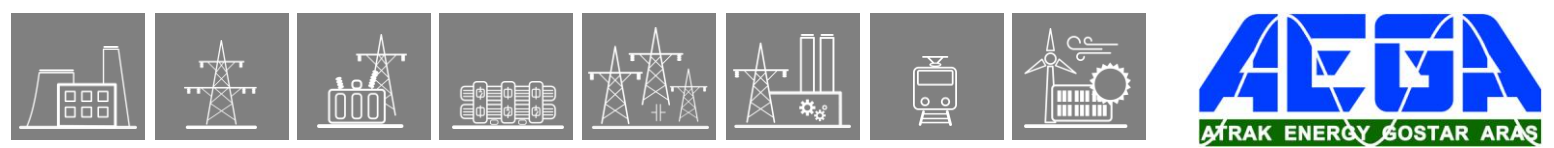

1. Introduction

The **DTVA** product type is a member of the **EuroProt+** product line, made by Protecta Co. Ltd. The **EuroProt+** complex protection in respect of hardware and software is a modular device. The modules are assembled and configured according to the requirements, and then the software determines the functions. This manual describes the **DTVA** product type.

1.1. Application

The **DTVA** product type is configured to protect, control and supervise the elements of the transmission network, where systems are typically solidly grounded. In these networks single phase-to-ground faults result in high currents, similar to line-to-line faults; therefore, both fault types need fast protection functions.

The relays of this type can be used for single- or three-phase tripping and support double breaker terminals such as breaker and a half or ring bus topology.

The main protection functions of the **DTVA** type include high-speed distance protection with five independent protection zones and line differential protection. The relays support the general teleprotection schemes (POTT, PUTT etc.).

Additionally, the **DTVA** product type includes a variety of versatile protection functions: directional and non-directional overcurrent protections, voltage-based protections and frequency-based protections.

The HV automatic reclosing function provides multi-shot autoreclosing with a synchro-check feature. The dead times can be set individually for each reclosing and separately for single-phase faults and multi-phase faults.

Because of the implemented control, measuring and monitoring function, the IEDs can also be used as a bay control unit.

The **EuroCAP configuration tool**, which is available free of charge, offers a user-friendly and flexible application for protection, control and measurement functions to ensure that the IED-EP+ devices are fully customizable.

1.1.1. General features

- Native IEC 61850 IED with Edition 2 compatibility
- Scalable hardware to adapt to different applications
- 84 HP or 42HP wide rack size (height: 3U)
- The pre-defined factory configuration can be customized to the user's specification with the powerful EuroCAP tool
- Flexible protection and control functionality to meet special customer requirements
- Advanced HMI functionality via color touchscreen and embedded WEB server, extended measuring, control and monitoring functions
- User configurable LCD user screens, which can display SLDs (Single Line Diagrams) with switchgear position indication and control as well as measuring values and several types of controllable objects.
- Various protection setting groups available
- Enhanced breaker monitoring and control
- High capacity disturbance recorder (DRE) and event logging (data is stored in non-volatile memory):
 - DRE for up to 32 analogue and 64 digital signal channels.
 - Event recorder can store more than 10,000 events.
- Several mounting methods: Rack; Flush mounting; Semi-flush mounting; Wall mounting; Wall-mounting with terminals; Flush mounting with IP54 rated cover.



- Wide range of communication protocols:
 - Ethernet-based communication: IEC61850; IEC60870-5-104; DNP3.0 TCP; Modbus TCP
 - Serial communication: DNP3.0; IEC60870-5-101/103; MODBUS, SPA
- The EuroProt+ family can handle several communication protocols simultaneously.
- Built-in self-monitoring to detect internal hardware or software errors
- Different time sources available: NTP server; Minute pulse; Legacy protocol master; IRIG-B000 or IRIG-B12X

1.2. Pre-defined configuration variants

The number and the functionality of the members of each product type is put together according to the application philosophy, keeping in mind the possible main usages. The available configurations of the DTVA type are listed in the table below.

VARIANT	MAIN APPLICATION
E1-Line	High-voltage distance protection, control and automation
E2-Line	Combined high-voltage distance and line differential protection, control and automation

Table 1-1 The members of the DTVA type

1.3. Hardware configuration

The minimum number of inputs and outputs are listed in the Table below.

Hardware configuration	ANSI	E2-Line
Mounting		Op.
Panel instrument case		
Current inputs (4th channel can be sensitive)		4
Voltage inputs		4
Digital inputs		12
Digital outputs		8
Fast trip outputs		4
Temperature monitoring (RTDs) *	38 / 49T	Op.

Table 3 The basic hardware configuration of the E2-Line configuration

The basic module arrangement of the E2-Line configuration is shown below.

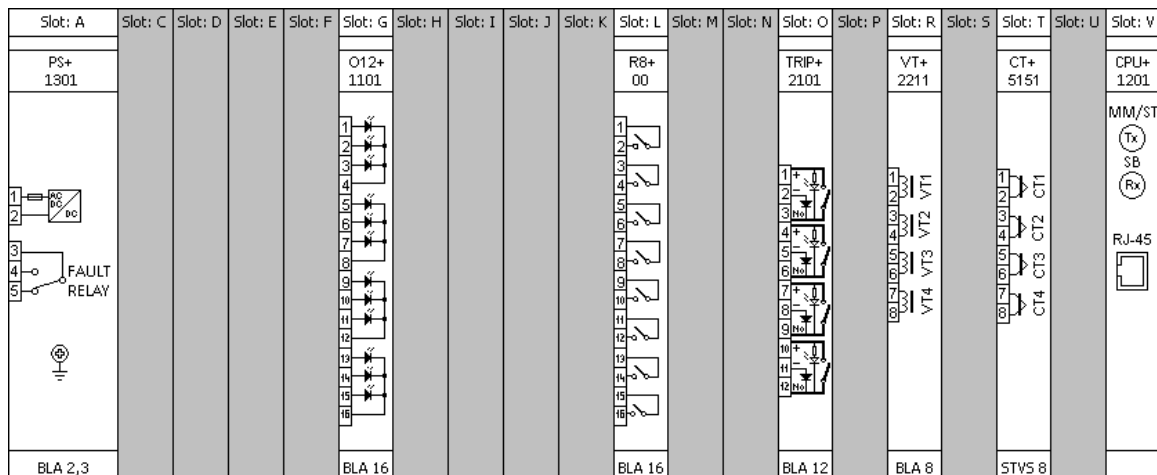

Figure 2 Basic module arrangement of the E2-Line configuration (84TE, rear view)

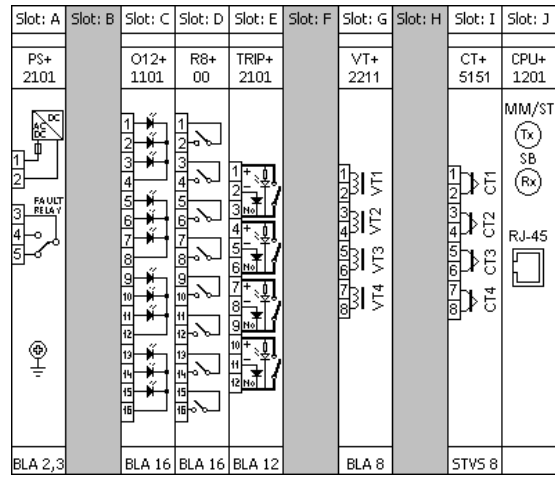
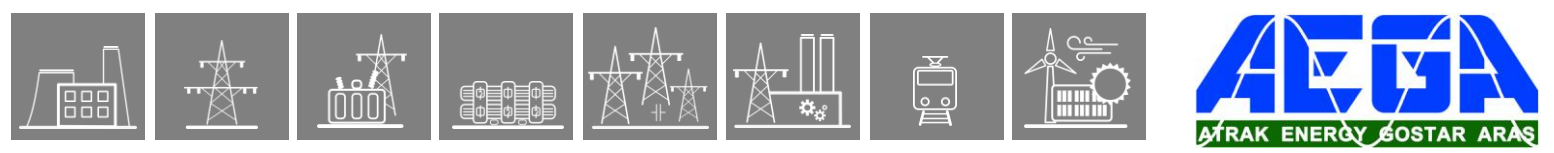
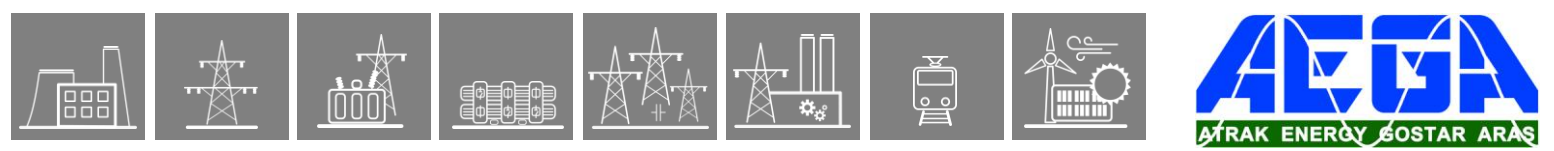

Figure 3 Basic module arrangement of the E2-Line configuration (42TE, rear view)



1.3.1. The applied hardware modules

The applied modules are listed in Table 4.

The technical specification of the device and that of the modules are described in the document “**Hardware description**”.

Module identifier	Explanation
PS+ 1301	Power supply unit (in 84TE)
PS+ 2101	Power supply unit (in 42TE)
PS+ 1301	Power supply unit
O12+ 1101	Binary input module
R8+ 00	Signal relay output module
TRIP+ 2101	Trip relay output module
VT+ 2211	Analog voltage input module
CT + 5151	Analog current input module
CPU+ 1281	Processing and communication module

Table 4 The applied modules of the E2-Line configuration

1.3.2. Meeting the device

The basic information for working with the **EuroProt+** devices are described in the document “**Quick start guide to the devices of the EuroProt+ product line**”.



*Figure 4 The 84 inch rack of **EuroProt+** family*



*Figure 5 The 42 inch rack of **EuroProt+** family*

1.3.3. System design

The EuroProt+ protection device family is a scalable hardware platform to adapt to different applications. Data exchange is performed via a 16-bit high-speed digital non-multiplexed parallel bus with the help of a backplane module.

Each module is identified by its location and there is no difference between module slots in terms of functionality. The only restriction is the position of the CPU module because it is limited to the “CPU” position. The built-in self-supervisory function minimizes the risk of device malfunctions.

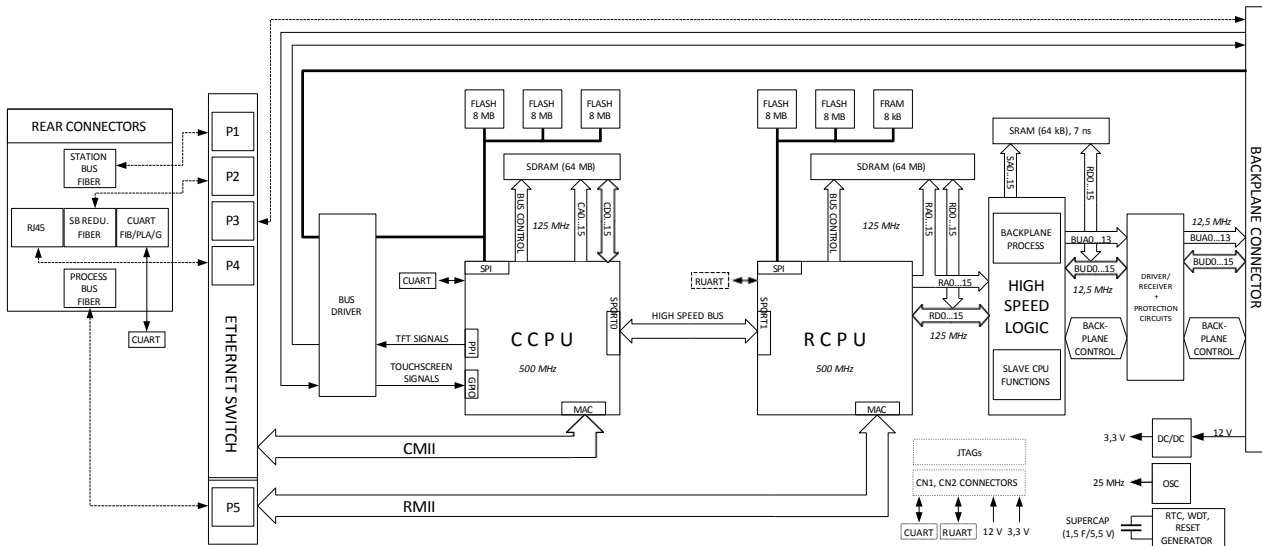
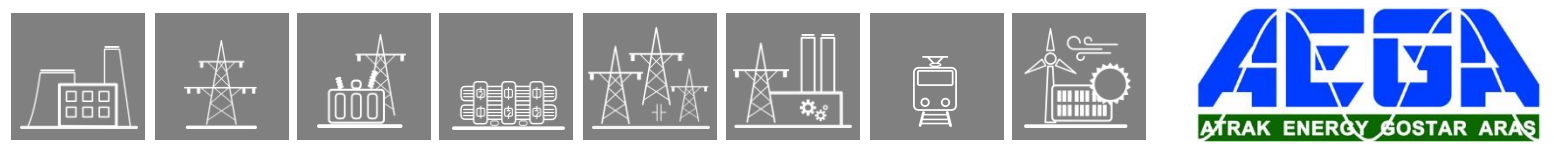

Figure 1-1 CPU block diagram

The backplane board itself is a passive board but it provides a 16-bit bus, power supply distribution, a two-wire interface (TWI) supporting module inventory management and module identification. It is designed to meet the requirements for high-speed digital buses and to comply with electromagnetic emission standards.



1.3.4. CPU and COM module

1.3.4.1. CPU+ module

The CPU module contains all the protection, control and communication functions of the EuroProt+ device. Dual 500 MHz high-performance Analog Devices Blackfin processors separate relay functions (RDSP) from communication and HMI functions (CDSP). Reliable communication between processors is performed via high-speed synchronous serial internal bus (SPORT).

Each processor has its own operative memory such as SDRAM and flash memories for configuration, parameter and firmware storage. Both firmwares are stored in a dedicated flash memory independent from the disturbance recorder and event storage.

The CDSP's operating system (uClinux) utilizes a robust JFFS flash file system, which enables fail-safe operation and the storage of disturbance record files, configuration and parameters.

The RDSP core runs at 500 MHz and its external bus speed is 125 MHz. The backplane data speed is limited to approx. 20 MHz, which is more than enough for module data throughput. An additional logic element (CPLD and SRAM) is used as a bridge between the RDSP and the backplane. The CPLD collects analogue samples from CT/VT modules and also controls signaling outputs and inputs.

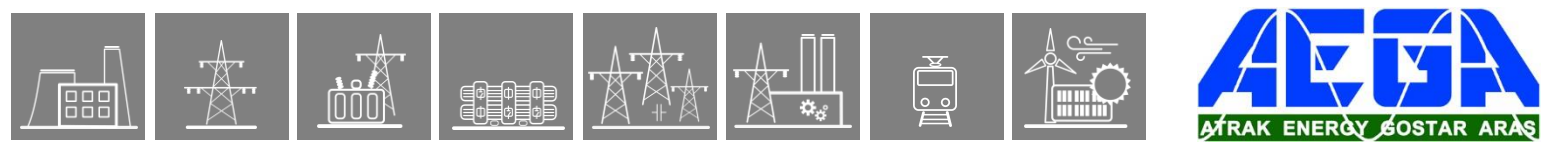

1.3.4.1.1. Fast start-up

After power-up the RDSP processor starts up with the previously saved configuration and parameters. Generally, the power-up procedure for the RDSP and relay functions takes only a few seconds. That is to say, it is ready to trip within this time. CDSP's start-up procedure is longer because its operating system needs time to build its file system, initializing user applications such as HMI functions and the IEC61850 software stack.

1.3.4.1.2. HMI and communication tasks

- Embedded WEB-server:
 - Firmware upgrade possibility
 - Modification of user parameters
 - Events list and disturbance records
 - Password management
 - Online data measurement
 - Commands
 - Administrative tasks
- Front panel TFT display handling: the interactive menu set is available through the TFT and the touchscreen interface
- User keys: capacitive touch keys on front panel
- The built-in 5-port Ethernet switch allows EuroProt+ to connect to IP/Ethernet-based networks. The following Ethernet ports are available:
 - Station bus (100Base-FX Ethernet) SBW
 - Redundant station bus (100Base-FX Ethernet) SBR
 - Process bus (100Base-FX Ethernet)
 - EOB2 (Ethernet Over Board) or RJ-45 Ethernet user interface on front panel
 - Optional 10/100Base-T port via RJ-45 connector
- PRP/HSR seamless redundancy for Ethernet networking (100Base-FX Ethernet)
- Other communication:
 - RS422/RS485 interfaces (galvanic interface to support legacy or other serial protocols, ASIF)
 - Plastic or glass fiber interfaces to support legacy protocols, ASIF
 - Proprietary process bus communication controller on COM+ module
 - Telecommunication interfaces: G.703, IEEE C37.94

CPU VERSION	PRIMARY STATION BUS SBW	SECONDARY (REDUNDANT) STATION BUS SBR	LEGACY PORT/PROTOCOL	PROCESS BUS (FIBER) PB	SERVICE PORT ON FRONT PANEL EOB/ RJ45
CPU+/0007	-	-	-	-	+
CPU+/0091	-	-	-	+ SM SH	+
CPU+/0201*	-	+ RJ45	-	-	+
CPU+/0211*	-	+ RJ45	-	+ MM	+
CPU+/0281*	-	+ RJ45	-	+ SM LH	+
CPU+/0291*	-	+ RJ45	-	+ SM SH	+
CPU+/0301	-	-	+ POF	-	+
CPU+/0401	-	-	+ GS	-	+
CPU+/0501*	-	-	+ Galv. RS485/422	-	+
CPU+/1001	+ MM	-	-	-	+
CPU+/1004	+ MM	-	-	-	+
CPU+/1011	+ MM	-	-	+ MM	+
CPU+/1091	+ MM	-	-	+ SM SH	+
CPU+/1101*	+ MM	+ MM	-	-	+
CPU+/1111	+ MM	+ MM	-	+ MM	+
CPU+/1181	+ MM	+ MM	-	+ SM LH	+
CPU+/1191	+ MM	+ MM	-	+ SM SH	+
CPU+/1201*	+ MM	+ RJ45	-	-	+
CPU+/1202	+ MM	+ RJ45	-	-	+
CPU+/1211	+ MM	+ RJ45	-	+ MM	+
CPU+/1281	+ MM	+ RJ45	-	+ SM LH	+
CPU+/1291*	+ MM	+ RJ45	-	+ SM SH	+
CPU+/1292	+ MM	+ RJ45	-	+ SM SH	+
CPU+/1301	+ MM	-	+ POF	-	+
CPU+/1311	+ MM	-	+ POF	+ MM	+
CPU+/1331	+ MM	-	+ double POF	-	+
CPU+/1381	+ MM	-	+ POF	+ SM LH	+
CPU+/1391	+ MM	-	+ POF	+ SM SH	+
CPU+/1401	+ MM	-	+ GS	-	+
CPU+/1411	+ MM	-	+ GS	+ MM	+
CPU+/1481	+ MM	-	+ GS	+ SM LH	+
CPU+/1491	+ MM	-	+ GS	+ SM SH	+
CPU+/1501	+ MM	-	+ Galv. RS485/422	-	+
CPU+/1511	+ MM	-	+ Galv. RS485/422	+ MM	+

CPU VERSION	PRIMARY STATION BUS (FIBER) SBW	SECONDARY (REDUNDANT) STATION BUS SBR	LEGACY PORT/PROTOCOL	PROCESS BUS (FIBER) PB	SERVICE PORT ON FRONT PANEL EOB/ RJ45
CPU+/1581	+ MM	-	+ Galv. RS485/422	+ SM LH	+
CPU+/1611	+ MM	-	+ Galvanic sync	+ MM	+
CPU+/1681	+ MM	-	+ Galvanic sync	+ SM LH	+
CPU+/6001	+ MM/LC	-	-	-	+
CPU+/6004	+ MM/LC	-	-	-	+
CPU+/6093	+ MM/LC	-	-	+ SM SH	+
CPU+/6094	+ MM/LC	-	-	+ SM SH	+
CPU+/6601*	+ MM/LC	+ MM/LC	-	-	+
CPU+/9201	+ SM SH	+ RJ45	-	-	+
CPU+/9291	+ SM SH	+ RJ45	-	+ SM SH	+
CPU+/9501	+ SM SH	-	+ Galv. RS485/422	-	+
CPU+/9901	+ SM SH	+ SM SH	-	-	+
CPU+/A001*	+ MM/LC PRP/HSR	-	-	-	+
CPU+/A004	+ MM/LC PRP/HSR	-	-	-	+
CPU+/A011	+ MM/LC PRP/HSR	-	-	+ MM	+
CPU+/A081	+ MM/LC PRP/HSR	-	-	+ SM LH	+
CPU+/A091	+ MM/LC PRP/HSR	-	-	+ SM SH	+
CPU+/A094	+ MM/LC PRP/HSR	-	-	+ SM SH	+

*Note: the modules can be equipped with a different handle (narrower and made of aluminum, instead of the standard plastic), if the other modules of the device are equipped with top-screw terminals (see Chapter 20.2). In these cases, a "T" letter appears on the label of the module (e.g. CPU+/1201T), but all other properties remain the same.

For legacy CPU cards (e.g. CPU+0001, ...) see [Product availability](#) chapter.

PRP/HSR option: A and F types can be ordered with PRP/HSR communication as sw option **Legend for CPU version table:**

MM: Multimode with ST connector	GS: Glass with ST connector
MM/LC: Multimode with LC connector	SFP: Small Form-factor Pluggable connector
SM: Single mode with FC/PC connector	SB: Station Bus
LH: Long Haul with FC/PC connector	SBW: Station Bus Working
SH: Short Haul with FC/PC connector	SBR: Station Bus Redundant
POF: Plastic Optical Fiber with 1 mm fiber connector	PB: Proprietary Process Bus

CPU+0007	CPU+0091	CPU+0201	CPU+0211	CPU+0281	CPU+0291	CPU+0301	CPU+0401	CPU+0501	CPU+1001	CPU+1004
									MM/ST	MM/ST
									Tx SB Rx	Tx SB Rx
		RJ-45	RJ-45	RJ-45	RJ-45	POF Tx Rx	GS/ST	Tx+ 1 Tx- 2 GND 3 Rx- 4 Rx+ 5		
	SM SH FCPC		MM/ST	SM LH FCPC	SM SH FCPC		Tx ASIF Rx			
	Tx PB Rx		Tx PB Rx	Tx PB Rx	Tx PB Rx					
CPU+1011	CPU+1091	CPU+1101	CPU+1111	CPU+1181	CPU+1191	CPU+1201	CPU+1202	CPU+1211	CPU+1281	CPU+1291
MM/ST	MM/ST	MM/ST	MM/ST	MM/ST	MM/ST	MM/ST	MM/ST	MM/ST	MM/ST	MM/ST
Tx SB Rx	Tx SB Rx	Tx SBW Rx	Tx SBW Rx	Tx SBW Rx	Tx SBW Rx	Tx SB Rx	Tx SBW Rx	Tx SB Rx	Tx SB Rx	Tx SB Rx
		MM/ST	MM/ST	MM/ST	MM/ST	RJ-45	RJ-45	RJ-45	RJ-45	RJ-45
MM/ST	SM SH FCPC	Tx SBR Rx	Tx SBR Rx	Tx SBR Rx	Tx SBR Rx			MM/ST	SM LH FCPC	SM SH FCPC
Tx PB Rx	Tx PB Rx		Tx PB Rx	Tx PB Rx	Tx PB Rx			Tx PB Rx	Tx PB Rx	Tx PB Rx
CPU+1292	CPU+1301	CPU+1311	CPU+1331	CPU+1381	CPU+1391	CPU+1401	CPU+1411	CPU+1481	CPU+1491	CPU+1501
MM/ST	MM/ST	MM/ST	MM/ST	MM/ST	MM/ST	MM/ST	MM/ST	MM/ST	MM/ST	MM/ST
Tx SBW Rx	Tx SB Rx	Tx SB Rx	Tx SB Rx	Tx SB Rx	Tx SB Rx	Tx SB Rx	Tx SB Rx	Tx SB Rx	Tx SB Rx	Tx SB Rx
RJ-45	POF	POF	POF1	POF	POF	GS/ST	GS/ST	GS/ST	GS/ST	Tx+ 1 Tx- 2 GND 3 Rx- 4 Rx+ 5
	Tx Rx	Tx Rx	Tx Rx	Tx Rx	Tx Rx	Tx ASIF Rx	Tx ASIF Rx	Tx ASIF Rx	Tx ASIF Rx	
SM SH FCPC		MM/ST	POF2	SM LH FCPC	SM SH FCPC		MM/ST	SM LH FCPC	SM SH FCPC	
Tx PB Rx		Tx PB Rx	Tx Rx	Tx PB Rx	Tx PB Rx		Tx PB Rx	Tx PB Rx	Tx PB Rx	

CPU+ 1511	CPU+ 1581	CPU+ 1611	CPU+ 1681	CPU+ 6001	CPU+ 6004	CPU+ 6093	CPU+ 6094	CPU+ 6601	CPU+ 9201	CPU+ 9291
MM/ST	MM/ST	MM/ST	MM/ST	MM/LC	MM/LC	MM/LC	MM/LC	MM/LC	SM SH FCPC	SM SH FCPC
Tx	Tx	Tx	Tx	Rx	Rx	Rx	Rx	Rx	Tx	Tx
SB	SB	SB	SB						SB	SB
Rx	Rx	Rx	Rx						Rx	Rx
Tx+ 1	Tx+ 1	-	-					MM/LC		
Tx- 2	Tx- 2	-	-					Rx	RJ-45	RJ-45
GND 3	GND 3	GND 3	GND 3							
Rx- 4	Rx- 4	Sy- 4	Sy- 4							
Rx+ 5	Rx+ 5	Sy+ 5	Sy+ 5							
MM/ST	SM LH FCPC	MM/ST	SM LH FCPC			SM SH FCPC	SM SH FCPC			SM SH FCPC
Tx	Tx	Tx	Tx			Tx	Tx			Tx
PB	PB	PB	PB			PB	PB			PB
Rx	Rx	Rx	Rx			Rx	Rx			Rx
CPU+ 9501	CPU+ 9901	CPU+ A001	CPU+ A004	CPU+ A011	CPU+ A081	CPU+ A091	CPU+ A094			
SM SH FCPC	SM SH FCPC	PRP/HSR MM/LC	PRP/HSR MM/LC	PRP/HSR MM/LC	PRP/HSR MM/LC	PRP/HSR MM/LC	PRP/HSR MM/LC			
Tx	Tx	Rx	Rx	Rx	Rx	Rx	Rx			
SB	PB	LAN A	LAN A	LAN A	LAN A	LAN A	LAN A			
Rx	Rx	LAN B	LAN B	LAN B	LAN B	LAN B	LAN B			
Tx+ 1	SM SH FCPC	A	A	A	A	A	A			
Tx- 2	Tx	B	B	B	B	B	B			
GND 3	PB	I	I	I	I	I	I			
Rx- 4	Rx	LINK/ACT	LINK/ACT	LINK/ACT	LINK/ACT	LINK/ACT	LINK/ACT			
Rx+ 5	Rx									
				MM/ST	SM LH FCPC	SM SH FCPC	SM SH FCPC			
				Tx	Tx	Tx	Tx			
				PB	PB	PB	PB			
				Rx	Rx	Rx	Rx			

Figure 2-1 CPU versions

Interface types:

- 100Base-FX Ethernet:
 - MM/ST 1300 nm, 50/62.5/125 μ m connector, (up to 2 km) fiber
 - SM/FC 1550 nm, 9/125 μ m connector, (LH: long haul, up to 120 km)
 - SM/FC 1550 nm, 9/125 μ m connector, (SH: short haul, up to 50 km)
 - MM/LC 1300 nm, 50/62.5/125 μ m connector, (up to 2 km) fiber
- 10/100 Base-TX Ethernet: RJ-45-8/8
- Service port on HMI:
 - 10/100 Base-T Ethernet: RJ-45-8/8
 - EOB2 interface: attachable to the front panel by a proprietary magnetic connector; the connector box ends in a RJ-45 8/8 plug. It is 10Base-T full duplex interface, and it enables 10/100Base TX communication with service computers.
- ASIF: Asynchronous Serial Interface
 - plastic optical fiber (ASIF-POF)
 - glass with ST connector (ASIF-GS)
 - galvanic RS485/422 (ASIF-G)

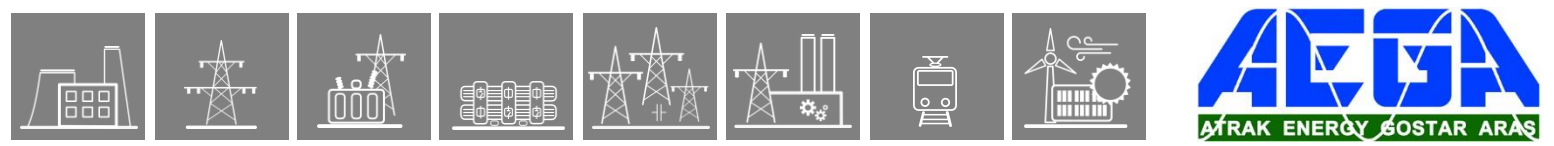

1.3.4.2. COM modules

The COM+ modules are responsible for special communication tasks, these are the following:

- binary signal transmission
- line differential protection communication via Ethernet or telecommunication networks
- busbar differential protection communication
- multi-port Ethernet switch using MODBUS/TCP protocol for Remote I/O (RIO) servers

1.3.4.2.1. COM modules for binary signal transmission

MODULE TYPE	INTERFACE TYPE	NUMBER OF INTERFACES	UNIT WIDTH	APPLICATION
COM+/1801*	MM/ST 1300 nm, 50/62.5/125 µm and SM/FC 1550 nm, 9/125 µm connector, 100Base-FX Ethernet	2	4 HP	Line differential protection, binary signal transmission up to 2 km and up to 120 km
COM+/1901*	MM/ST 1300 nm, 50/62.5/125 µm and SM/FC 1550 nm, 9/125 µm connector, 100Base-FX Ethernet	2	4 HP	Line differential protection, binary signal transmission up to 2 km and up to 50 km
COM+/8882	SM/FC 1550 nm, 9/125 µm connector, 100Base-FX Ethernet	3	4 HP	3 direction binary signal transmission up to 120 km
COM+/9902	SM/FC 1550 nm, 9/125 µm connector, 100Base-FX Ethernet	2	4 HP	2 direction binary signal transmission up to 50 km
COM+/9992	SM/FC 1550 nm, 9/125 µm connector, 100Base-FX Ethernet	3	4 HP	3 direction binary signal transmission up to 50 km

*Note: the modules can be equipped with a different handle (narrower and made of aluminum, instead of the standard plastic), if the other modules of the device are equipped with top-screw terminals (see Chapter 20.2). In these cases, a "T" letter appears on the label of the module (e.g. **COM+/1801T**), but all other properties remain the same

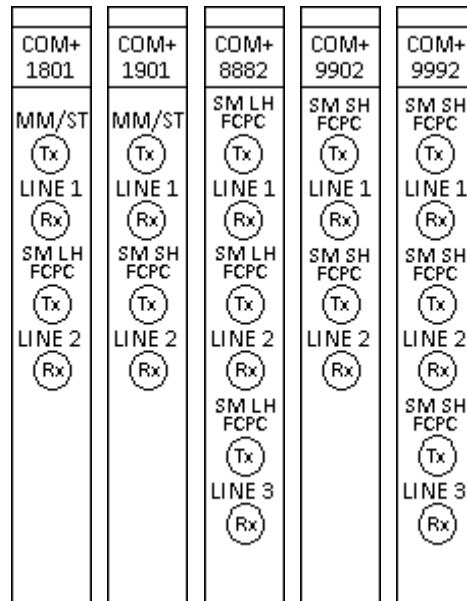

Figure 2-2 COM modules for binary signal transmission

1.3.4.2.2. COM modules for line differential communication

MODULE TYPE	INTERFACE TYPE	NUMBER OF INTERFACES	UNIT WIDTH	APPLICATION
COM+/0091	G703.1 (64 kbit/s)	1	4 HP	Line differential protection via telecom network
COM+/1101	MM/ST 1300 nm, 50/62.5/125 µm connector, 100Base-FX Ethernet	2	4 HP	3 terminals / redundant line differential protection up to 2 km
COM+/1801*	MM/ST 1300 nm, 50/62.5/125 µm and SM/FC 1550 nm, 9/125 µm connector, 100Base-FX Ethernet	2	4 HP	3 terminals / redundant line differential protection up to 2 km and up to 120 km
COM+/1901*	MM/ST 1300 nm, 50/62.5/125 µm and SM/FC 1550 nm, 9/125 µm connector, 100Base-FX Ethernet	2	4 HP	3 terminals / redundant line differential protection up to 2 km and up to 50 km
COM+/8801	SM/FC 1550 nm, 9/125 µm connector, 100Base-FX Ethernet	2	4 HP	3 terminals / redundant line differential protection up to 120 km
COM+/9901	SM/FC 1550 nm, 9/125 µm connector, 100Base-FX Ethernet	2	4 HP	3 terminals / redundant line differential protection up to 50 km

Note: the modules can be equipped with a different handle (narrower and made of aluminum, instead of the standard plastic), if the other modules of the device are equipped with top-screw terminals (see Chapter 20.2). In these cases, a "T" letter appears on the label of the module (e.g. **COM+/1801T), but all other properties remain the same*

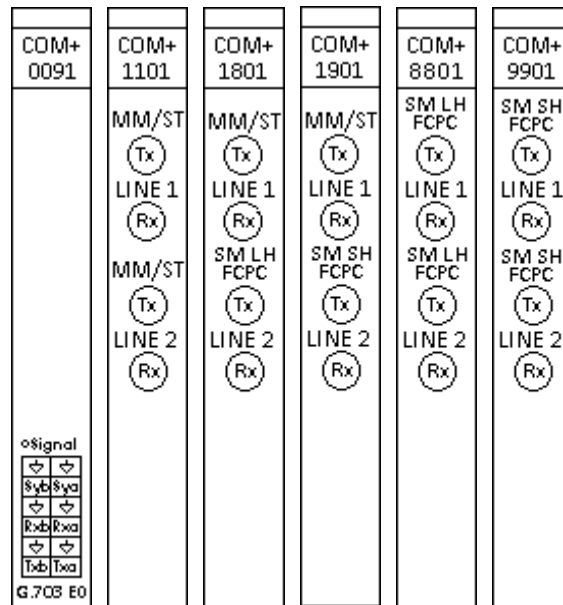

Figure 2-3 COM modules for line differential applications

1.3.4.2.3. COM modules for busbar differential protection communication

MODULE TYPE	INTERFACE TYPE	NUMBER OF INTERFACES	UNIT WIDTH	APPLICATION
COM+/1111	MM/ST 1300 nm, 50/62.5/125 μ m connector, 100Base-FX Ethernet	3	4 HP	Busbar protection for 3 bay units up to 2 km
COM+/1111D	MM/ST 1300 nm, 50/62.5/125 μ m connector, 100Base-FX Ethernet	3	4 HP	Busbar protection for 3x2 bay units (dual) up to 2 km

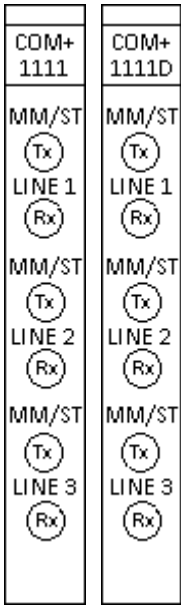

Figure 2-4 COM modules for busbar differential protections

1.3.4.2.4. COM modules for Remote I/O (RIO) servers

MODULE TYPE	INTERFACE TYPE	NUMBER OF INTERFACES	UNIT WIDTH	APPLICATION
COM+/1202*	MM/LC 1300 nm, 50/62.5/125 µm connector, 100Base-FX Ethernet	2	8 HP	2-port Ethernet switch for MODBUS via RIO
COM+/1324*	MM/LC 1300 nm, 50/62.5/125 µm connector, 100Base-FX Ethernet	4	8 HP	4-port Ethernet switch for MODBUS via RIO
COM+/1335	MM/LC 1300 nm, 50/62.5/125 µm connector, 100Base-FX Ethernet	5	8 HP	5-port Ethernet switch for MODBUS via RIO
COM+/6603	MM/LC 1300 nm, 50/62.5/125 µm connector, 100Base-FX Ethernet	2	4 HP	2-port Ethernet switch for MODBUS via RIO
COM+/6663	MM/LC 1300 nm, 50/62.5/125 µm connector, 100Base-FX Ethernet	3	4 HP	3-port Ethernet switch for MODBUS via RIO

*Obsolete module. These modules are not recommended for new designs!

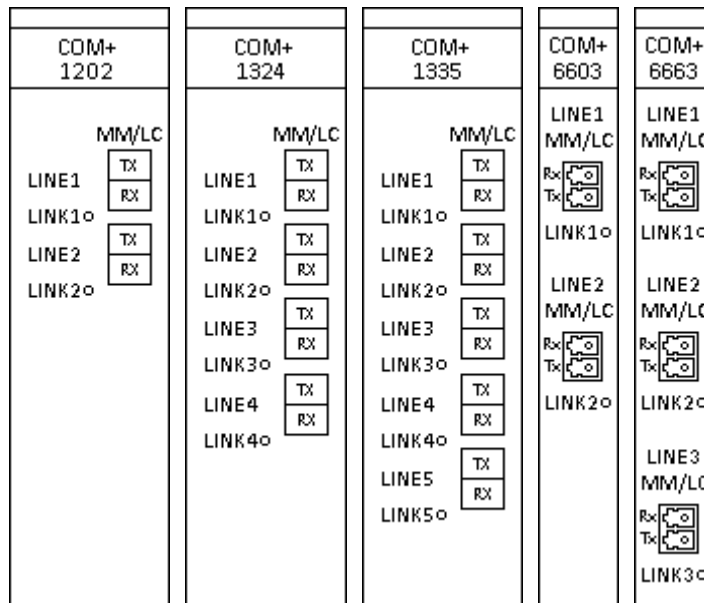

Figure 2-5 COM modules for RIO servers

1.3.4.3. Communication interface characteristics

1.3.4.3.1. Ethernet multi-mode transmitter and receiver

1.3.4.3.1.1. MM/ST connector

Up to approximately 2 km.

Transmitter

PARAMETER	SYMBOL	MIN.	TYP.	MAX.	UNIT
OPTICAL OUTPUT POWER 62.5/125 μm , NA = 0.275 FIBER	P_O	BOL*: -19 EOL*: -20	-	-14	dBm avg.
OUTPUT OPTICAL POWER 50/125 μm , NA = 0.20 FIBER	P_O	BOL*: -22.5 EOL*: -23.5	-	-14	dBm avg.
OPTICAL EXTINCTION RATIO	ER	-	-	10 -10	% dB
CENTER WAVELENGTH	λ_C	1270	1308	1380	nm

* BOL: Beginning of life, EOL: End of life

Note: according to field experiences, the 62.5/125 μm cabling is recommended for applications where the center wavelength is 1300/1310 nm.

Receiver sensitivity is measured with $2^{23} - 1$ PRBS pattern within BER = 2.5×10^{-10}

PARAMETER	SYMBOL	MIN.	TYP.	MAX.	UNIT
SIGNAL DETECT - ASSERTED	P_A	$P_D + 1.5$ dB	-	-33	dBm avg.
SIGNAL DETECT - DEASSERTED	P_D	-45	-	-	dBm avg.
SIGNAL DETECT - HYSTERESIS	$P_A - P_D$	1.5	-	-	dB
SIGNAL DETECT ASSERT TIME (OFF TO ON)	AS_Max	0	2	100	μs
SIGNAL DETECT DEASSERT TIME (ON TO OFF)	ANS_Max	0	8	350	μs

1.3.4.3.1.2. MM/LC connector

Up to approximately 2 km.

Transmitter

PARAMETER	SYMBOL	MIN.	TYP.	MAX.	UNIT
OPTICAL OUTPUT POWER** 62.5/125 μm , NA = 0.275 FIBER	P_o	BOL*: -19 EOL*: -20	-15.7	-14	dBm avg.
OUTPUT OPTICAL POWER 50/125 μm , NA = 0.20 FIBER	P_o	BOL*: -22.5 EOL*: -23.5	-	-14	dBm avg.
OPTICAL EXTINCTION RATIO	ER	-	0.002 -47	0.2 -27	% dB
CENTER WAVELENGTH	λ_c	1270	1308	1380	nm

* BOL: Beginning of life, EOL: End of life

Note: according to field experiences, the 62.5/125 μm cabling is recommended for applications where the center wavelength is 1300/1310 nm.

Receiver sensitivity is measured with $2^{23} - 1$ PRBS pattern within BER = 2.5×10^{-10}

PARAMETER	SYMBOL	MIN.	TYP.	MAX.	UNIT
SIGNAL DETECT - ASSERTED	P_A	$P_D + 1.5 \text{ dB}$	-	-33	dBm avg.
SIGNAL DETECT - DEASSERTED	P_D	-45	-	-	dBm avg.
SIGNAL DETECT - HYSTERESIS	$P_A - P_D$	1.5	-	-	dB
SIGNAL DETECT ASSERT TIME (OFF TO ON)	AS_Max	0	2	100	μs
SIGNAL DETECT DEASSERT TIME (ON TO OFF)	ANS_Max	0	5	100	μs

1.3.4.3.2. Ethernet single mode transmitter and receiver

1.3.4.3.2.1. Long haul single mode transceiver

Up to approximately 120 km, with max. 32 dB link attenuation.

Transmitter

PARAMETER	SYMBOL	MIN.	TYP.	MAX.	UNIT
OPTICAL OUTPUT POWER	P_O	-6	-	0	dBm avg.
OPTICAL EXTINCTION RATIO	ER	8.3	-	-	dB
CENTER WAVELENGTH	λ_C	1490	1550	1610	nm

Receiver sensitivity is measured with $2^{23} - 1$ PRBS pattern within $BER = 2.5 \times 10^{-10}$

PARAMETER	SYMBOL	MIN.	TYP.	MAX.	UNIT
OPTICAL INPUT SENSITIVITY	P_{IN}	-	-38	-35	dBm avg.
SATURATION	P_{SAT}	-3	0	-	dBm
CENTER WAVELENGTH	λ_C	1100	-	1600	nm
SIGNAL DETECT - ASSERTED	P_A	-	-	-35	dBm avg.
SIGNAL DETECT - DEASSERTED	P_D	-45	-	-	dBm avg.
HYSTERESIS	P_{HYS}	-	3	-	dB

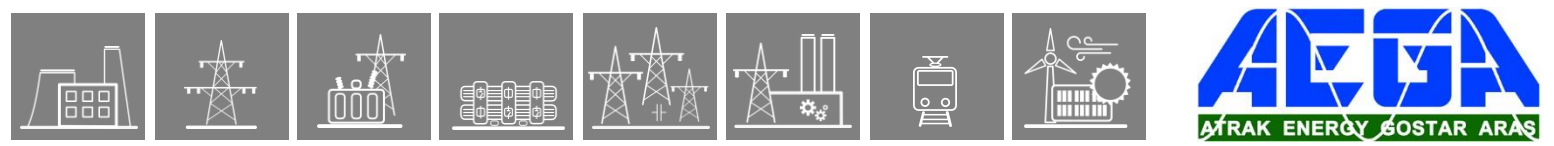

1.3.4.3.2.2. Short haul single mode transceiver

Up to approximately 50 km, with max. 27 dB link attenuation.

Transmitter

PARAMETER	SYMBOL	MIN.	TYP.	MAX.	UNIT
OPTICAL OUTPUT POWER	P_O	-12	-	-6	dBm avg.
OPTICAL EXTINCTION RATIO	ER	8.3	-	-	dB
CENTER WAVELENGTH	λ_C	1490	1550	1610	nm

Receiver sensitivity is measured with $2^{23} - 1$ PRBS pattern within $BER = 2.5 \times 10^{-10}$

PARAMETER	SYMBOL	MIN.	TYP.	MAX.	UNIT
OPTICAL INPUT SENSITIVITY	P_{IN}	-	-38	-35	dBm avg.
SATURATION	P_{SAT}	-3	0	-	dBm
CENTER WAVELENGTH	λ	1100	-	1600	nm
SIGNAL DETECT - ASSERTED	P_A	-	-	-35	dBm avg.
SIGNAL DETECT - DEASSERTED	P_D	-45	-	-	dBm avg.
HYSTERESIS	P_{HYS}	-	3	-	dB

1.3.4.3.3. ASIF-O transmitter and receiver

1.3.4.3.3.1. ASIF-O POF

Transmitter

PARAMETER	SYMBOL	MIN.	TYP.	MAX.	UNIT	JUMPER SETTINGS
TRANSMITTER OUTPUT OPTICAL POWER	P_T	-15.3	-	-9	dBm	JP1 2-3
		-23.3	-	-17		JP1 1-2
PEAK EMISSION WAVELENGTH	λ_{PK}	-	660	-	nm	
EFFECTIVE DIAMETER	D	-	1	-	mm	
NUMERICAL APERTURE	NA	-	0.5	-		

Receiver

PARAMETER	SYMBOL	MIN.	TYP.	MAX.	UNIT
INPUT OPTICAL POWER LEVEL LOGIC 0	$P_{R(L)}$	-39	-	-13.7	dBm
INPUT OPTICAL POWER LEVEL LOGIC 1	$P_{R(H)}$	-	-	-53	dBm
EFFECTIVE DIAMETER	D	-	1	-	mm
NUMERICAL APERTURE	NA	-	0.5	-	

These characteristics are valid for both POF interfaces in CPU+1331 module.

1.3.4.3.3.2. ASIF-O GLASS

Transmitter (Output measured out of 1 meter of cable)

PARAMETER	SYMBOL	MIN.	TYP.	MAX.	UNIT	JUMPER SETTINGS
50/125 μm FIBER CABLE NA = 0.2	P_o	-19.4	-16.4	-14.4	dBm peak	JP1 2-3
		-28.9	-25.9	-23.9		JP1 1-2
62.5/125 μm FIBER CABLE NA = 0.275	P_o	-15.6	-12.6	-10.6	dBm peak	JP1 2-3
		-22.9	-19.9	-17.9		JP1 1-2

Receiver

PARAMETER	SYMBOL	MIN.	TYP.	MAX.	UNIT
PEAK OPTICAL INPUT POWER LOGIC LEVEL HIGH ($\lambda_P = 820 \text{ nm}$)	P_{RH}	-25.4	-	-9.2	dBm peak
PEAK OPTICAL INPUT POWER LOGIC LEVEL LOW	P_{RL}	-	-	-40	dBm peak

1.3.4.3.4. ASIF-G transmitter and receiver

The RS422/RS485 interfaces of our CPU+1501, CPU+1511, CPU+1581, CPU+9501 modules provide galvanic interface to support legacy or other serial protocols. For more details see our RS485/422 application note, available on our homepage.

Transmitter

PARAMETER	SYMBOL	MIN.	TYP.	MAX.	UNIT
DIFFERENTIAL OUTPUT VOLTAGE (LOADED, $R_L = 100 \Omega$, RS422)	V_{OD2}	2	-	3.6	V
DIFFERENTIAL OUTPUT VOLTAGE (LOADED, $R_L = 54 \Omega$, RS485)	V_{OD2}	1.5	-	3.6	V

Receiver

PARAMETER	SYMBOL	MIN.	TYP.	MAX.	UNIT
DIFFERENTIAL INPUT THRESHOLD VOLTAGE	V_{TH}	-200	-125	-30	mV
INPUT VOLTAGE HYSTERESIS	V_{HYS}	-	15	-	mV
LINE INPUT RESISTANCE	R_{IN}	96	-	-	k Ω

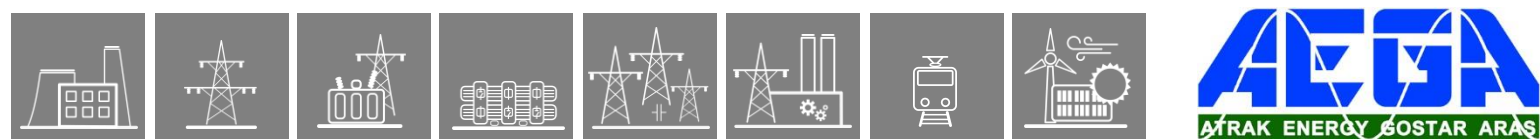

1.3.4.3.5. G.703 64 kbit/s co-directional interface (E0)

The EuroProt+ device also supports line differential communication via telecom networks using

- 64 kbit/s co-directional interface type through COM+0091. This type of communication is performed via 2 x 2 wire isolated galvanic type interface. The protection device is connected to a multiplexer or gateway which is responsible for protocol/speed conversion.

- Connector type: Weidmüller: Receptacle: S2L 3.50/12/90 F
Plug: B2L 3.50/12/180 F
- Impedance: 120 Ω
- Cable length: 50 m
- Interface type: G.703.1 64 kbit/s (E0) co-directional, selectable grounding, with optional external clock input

For further information about the cable assembly of this type of interface please see our G.703 E0 cable assembly guide.

Receiver

PARAMETER	VALUE
LOSS OF SIGNAL ALARM LEVEL	± 1.5 dB difference between alarm-on and alarm-off
DYNAMIC RANGE	10 dB maximum cable loss range

Transmitter

PARAMETER	VALUE
PAIR FOR EACH DIRECTION	± 1.5 dB difference between alarm-on and alarm-off
TEST LOAD IMPEDANCE	10 dB maximum cable loss range
NOMINAL PEAK VOLTAGE OF A “MARK” (PULSE)	One symmetric pair
PEAK VOLTAGE OF A “SPACE” (NO PULSE)	120 Ω resistive
NOMINAL PULSE WIDTH	1.0 V
RATIO OF THE AMPLITUDES OF POSITIVE AND NEGATIVE	0 V ± 0.10 V
PULSES AT THE CENTRE OF THE PULSES INTERVAL	3.9 ms
RATIO OF THE WIDTHS OF POSITIVE AND NEGATIVE PULSES	0.95 to 1.05
AT THE NOMINAL HALF AMPLITUDE	0.95 to 1.05
MAXIMUM PEAK-TO-PEAK JITTER AT THE OUTPUT PORT	Refer to clause 2/G.823

1.3.4.3.5.1. PRP/HSR redundant Ethernet communication interface

The PRP/HSR redundant Ethernet communication interface supports the two new IEC 62439-3 protocols which provide seamless redundancy for Ethernet networking in substations with zero-time recovery in case of a single failure without frame loss:

- PRP – Parallel Redundancy Protocol (IEC 62439-3 Clause 4)
- HSR – High-availability Seamless Redundancy (IEC 62439-3 Clause 5)

This interface uses two MM/LC connectors for double connection to networks as these protocols are based on the duplication of the sent frames.

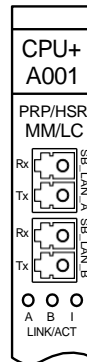

Figure 2-6 PRP/HSR connectors on a CPU+A001 module

1.3.4.3.5.2. Parallel Redundancy Protocol (PRP)

This redundancy protocol implements redundancy in the nodes as they are connected to two independent networks (LAN_A and LAN_B) sending a copy of each frame to both directions. The destination node receives and processes the first copy and discards the other copy of the sent frame.

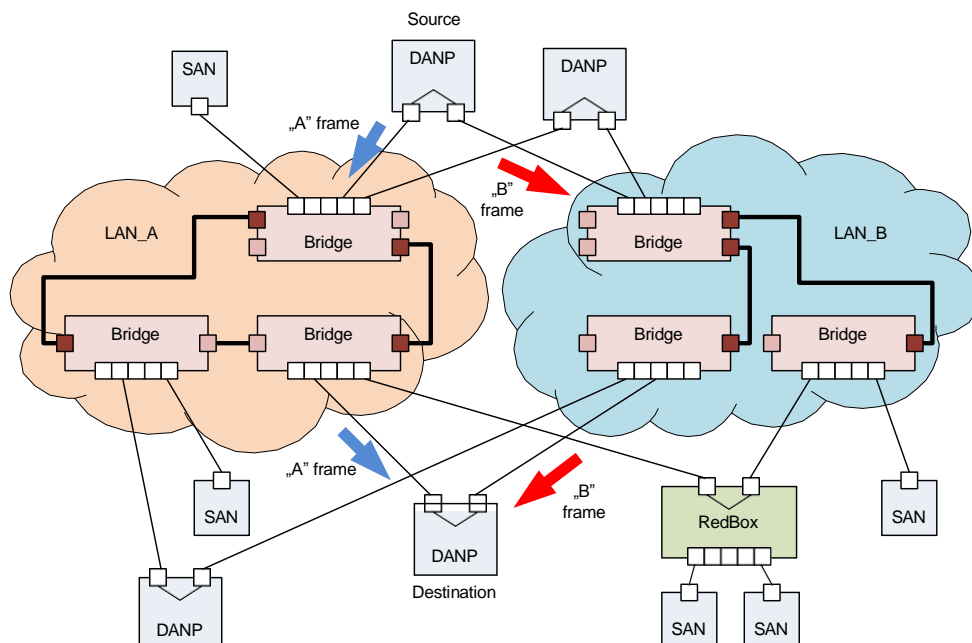

Figure 2-7 Example of a PRP redundant network

Single attached node (SAN): Network device that connects to a network with only one port.

Double attached node implementing PRP (DANP): Network device which connects to a network with two ports implementing PRP redundancy.

1.3.4.3.5.3. High-availability Seamless Redundancy (HSR)

An HSR network provides redundancy with the same safety as PRP does with a lower cost. The principle of this protocol is also based on the duplication of the sent frames but in this solution the nodes are connected to a closed ring. A source node sends two copy of a frame to both direction and the destination node accepts the first received copy and discards the other one. If a frame returns to its source the node does not let it through itself prevent the possibility of an overload of the ring.

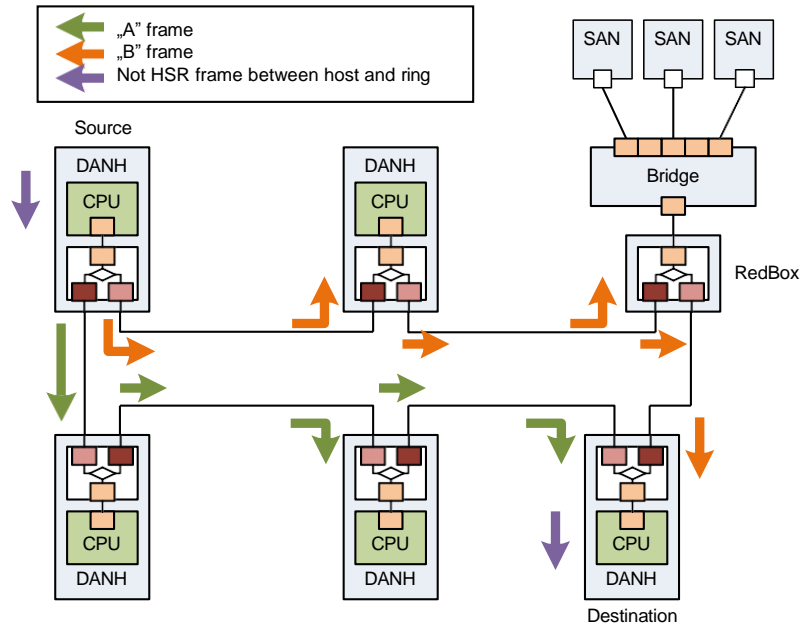
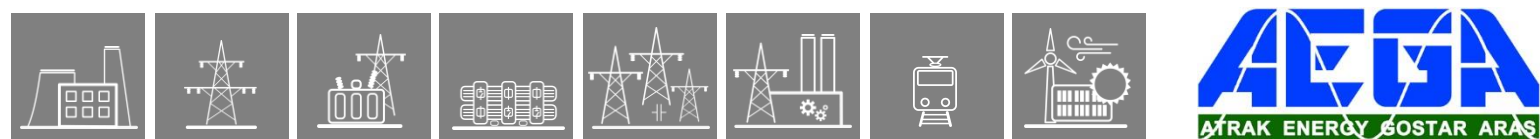

Figure 2-8 Example of an HSR redundant network

Single attached node (SAN): Network device that connects to a network with only one port.
 Double attached node implementing HSR (DANH): Network device which connects to a network with two ports implementing HSR redundancy.



1.3.5. Device housings

Three+one versions are available: one is 84 HP wide with 21 module slots, the 42 HP wide, which supports 10 module slots, the double 42 HP wide with 20 module slots, and finally the 24 HP, which supports 6 module slots.

Depending on the installed modules of the configuration, the top and bottom panels of the 84 HP and 42 HP racks can be either solid (default) or perforated by 2 mm holes to prevent overheating. 24 HP housings do not have this feature, as the S24 system is less flexible, their range of the optional modules are narrower.

RACK CONFIGURATION	FREE MODULE SLOTS*	BOTTOM AND TOP PANELS	DISPLAY OPTIONS
84 HP, SINGLE RACK (3 U)	20	Solid, Perforated	3.5" TFT, 5.7" TFT
42 HP, SINGLE RACK (3 U)	9	Solid, Perforated	3.5" TFT, 5.7" TFT
42 HP, DOUBLE RACK (6 U)	19	Solid, Perforated	3.5" TFT
24 HP, PANEL INSTRUMENT CASE	5	Solid	B/W alphanumeric 3.5" TFT

**CPU module is mandatory, it uses up one fixed position*

Previously, a new rack type has been introduced to the 42HP devices. As of April 2021. this type is introduced to the 84HP devices as well. The depth of the box has been reduced from 242 mm to 223 mm. By default, this reduced-depth housing shall be used for newly manufactured devices. For more information about the previous and new size, see Chapter 22.1.

The following images showcase examples of the different types of available device housings with different kinds of front panel HMI. The available front panels are listed in Chapter 4.





<p>84 HP single rack (3 U) with 3.5" TFT display and solid housing</p>	
<p>84 HP single rack (3 U) with 5.7" TFT display and perforated housing</p>	
<p>42 HP single rack (3 U) with 3.5" TFT display and solid housing</p>	
<p>42 HP double rack (6 U) with 3.5" TFT display and solid housing</p>	
<p>24 HP panel instrument case with B/W display (left) TFT display (right)</p>	







Figure 3-1 Rack configuration illustrations

1.3.6. Human-Machine Interface (HMI) module

The EuroProt+ device HMI consists of the following two main parts:

- Hardware: the HMI module, which is the front panel of the device, this is described here
- Software: the embedded web server and the menu system that is accessible through the HMI module. The web server is accessible via station bus, EOB interface or RJ-45 Ethernet connector. This is described in detail in the [Operating Manual](#) (external document).

1.3.6.1. Local HMI modules

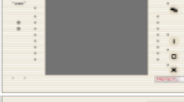
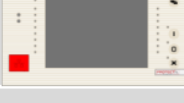
MODULE TYPE	DISPLAY	SERVICE PORT	RACK SIZE	RACK DEPTH	ILLUSTRATION
HMI+/3505 HMI+/3405*	3,5" TFT	EOB	42 HP	Reduced	
			84 HP		
HMI+/3506 HMI+/3406* HMI+/3404*	3,5" TFT	RJ-45	42 HP	Reduced	
			Double 42HP		
			84 HP		
HMI+/5005	5,7" TFT	EOB	42 HP	Reduced	
HMI+/5006 HMI+/5004*	5,7" TFT	RJ-45	42 HP	Reduced	
			Double 42 HP		n/a
HMI+/5706 HMI+/5704*	5,7" TFT	RJ-45	84 HP	Reduced	

**new display hardware requires CDSP firmware version 1560-H5 or higher!*

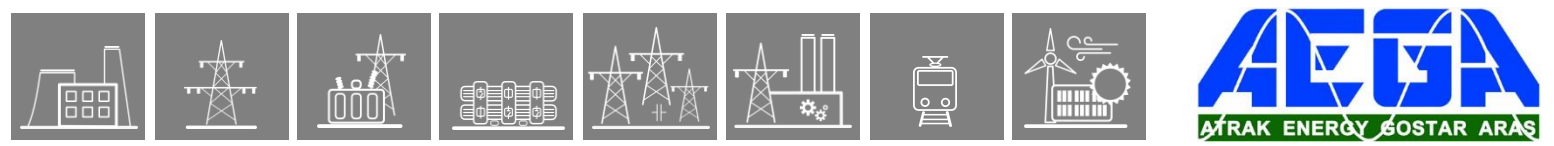

The following modules were made for the previous (now obsolete) racks (see Chapter 22.1), so they can be found in numerous devices. These became obsolete as well, **they are not recommended for new designs!**

MODULE TYPE	DISPLAY	SERVICE PORT	RACK SIZE	RACK DEPTH	ILLUSTRATION
HMI+/3501	3,5" TFT	EOB	42 HP	Normal	
			84 HP		
HMI+/3502	3,5" TFT	RJ-45	42 HP	Normal	
			84 HP		
HMI+/5001	5,7" TFT	EOB	42 HP	Normal	
HMI+/5002	5,7" TFT	RJ-45	42 HP	Normal	
HMI+/5701	5,7" TFT	EOB	84 HP	Normal	
HMI+/5702	5,7" TFT	RJ-45	84 HP	Normal	

1.3.6.2. Remote HMI

Protecta provides an alternative solution in that case if the IED can be only mounted in a non-practical way for managing the device via usual Human-Machine Interface.

By using a remote HMI (*terminal HMI device*), customers can place the HMI up to 3 meters far from the IED itself (*host device*) and mount the IED in any possible way that is applicable. The connection between the remote HMI and the IED is provided by a custom galvanic interface with DA-15 connector on the remote side.



Depending on the size of the HMI module you can use any applicable mounting methods that described in the [Mounting methods](#) chapter (Flush mounting, Semi-flush mounting, Rack mounting).

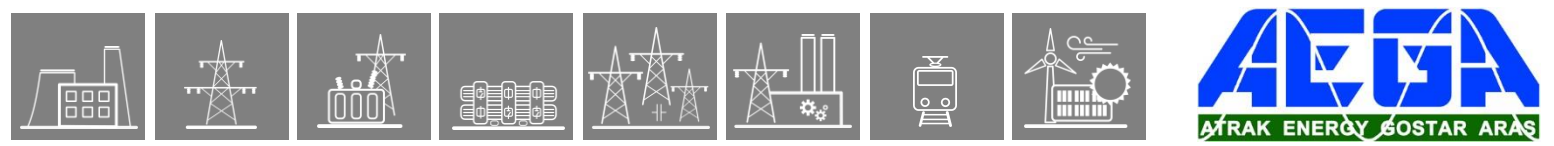

Figure 4-1 42 HP Remote HMI



Figure 4-2 Remote HMI module with its host device

MODULE TYPE	DISPLAY	SERVICE PORT	RACK SIZE	RACK DEPTH	ILLUSTRATION
HMIT+/3505	3,5" TFT	EOB	42 HP	Reduced	
			84 HP		
HMIT+/3506	3,5" TFT	RJ-45	42 HP	Reduced	
			84 HP		
HMIT+/5706	5,7" TFT	RJ-45	84 HP	Reduced	







The following modules were made for the previous (now obsolete) racks (see Chapter 22.1), so they can be found in numerous devices. These became obsolete as well, **they are not recommended for new designs!**

MODULE TYPE	DISPLAY	SERVICE PORT	RACK SIZE	RACK DEPTH	ILLUSTRATION
HMIT+/3501	3,5" TFT	EOB	42 HP	Normal	
			84 HP		
HMIT+/3502	3,5" TFT	RJ-45	42 HP	Normal	
			84 HP		
HMIT+/5702	5,7" TFT	RJ-45	84 HP	Normal	

1.3.6.3. S24 HMI

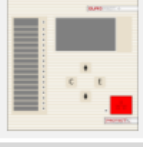
The S24 Smart Line devices have a different HMI family:

MODULE TYPE	DISPLAY	SERVICE PORT	RACK SIZE	MOUNTING	ILLUSTRATION
HMI+/2604* HMI+/2404 HMI+/2304**	3,5" TFT	RJ-45	24 HP	Normal	
HMI+/2606* HMI+/2406 HMI+/2306**	3,5" TFT	RJ-45	24 HP	DIN-rail	
HMI+/2704* HMI+/2504	B&W LCD	RJ-45	24 HP	Normal	
HMI+/2706* HMI+/2506	B&W LCD	RJ-45	24 HP	DIN-rail	

*for newer, modular-type S24 devices

**new display hardware requires CDSP firmware version 1560-H5 or higher!

The following module is **obsolete, it is not recommended for new designs!**

MODULE TYPE	DISPLAY	SERVICE PORT	RACK SIZE	MOUNTING	ILLUSTRATION
HMI+/2401*	3,5" TFT	EOB	24 HP	Normal	

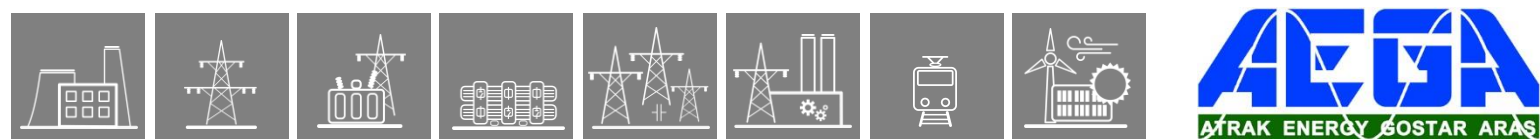

1.3.6.4. Parts of the HMI modules

The EuroProt+ device HMI on the front panel contains the following elements:

Function	Description
16 PIECES USER LEDs	Three-color, 3 mm circular LEDs
COM LED	Yellow, 3 mm circular LED indicating EOB/RJ-45 (on the front panel) communication link and activity
CAPACITIVE TOUCH KEY LEDs	4 pcs yellow, 3 mm circular LEDs indicating touch key actions
DEVICE STATUS LED	1 piece three-color, 3 mm circular LED Green: normal device operation Yellow: device is in warning state Red: device is in error state
DEVICE KEYS (I, O, X, PAGE)	Capacitive touch keys
	Tactile push buttons
BUZZER	Audible touch key pressure feedback
CHANGEABLE LED DESCRIPTION LABEL	Describes user LED functionality
DISPLAY	320 × 240 pixel TFT color display with resistive touchscreen interface (3.5" or optional 5.7")
	128 × 64 LCD black & white display
OPTICAL INTERFACE FOR FACTORY USAGE	For debugging and software development purposes <i>Only for 42 HP and 84 HP devices.</i>
EOB CONNECTOR	<p>Ethernet Over Board: communication interface accomplishes isolated, non-galvanic Ethernet connection with the help of a magnetically attached EOB device. The EOB device has an RJ-45 type connector supporting Ethernet connection to the user computer. This is a proprietary and patented solution from Protecta Ltd.</p> <p>EOB1: Supporting 10Base-T Ethernet connection. Passive device with one RJ45 type connector. Obsolete module.</p> <p>EOB2: Supporting 10/100Base-Tx Ethernet connection. An active device that has a USB port in addition to the RJ45 connector for powering up.</p>
ETHERNET SERVICE PORT	IP56 rated Ethernet 10/100-Base-T interface with RJ-45 type connector (IP56 only valid if the cap of the service port is closed.)

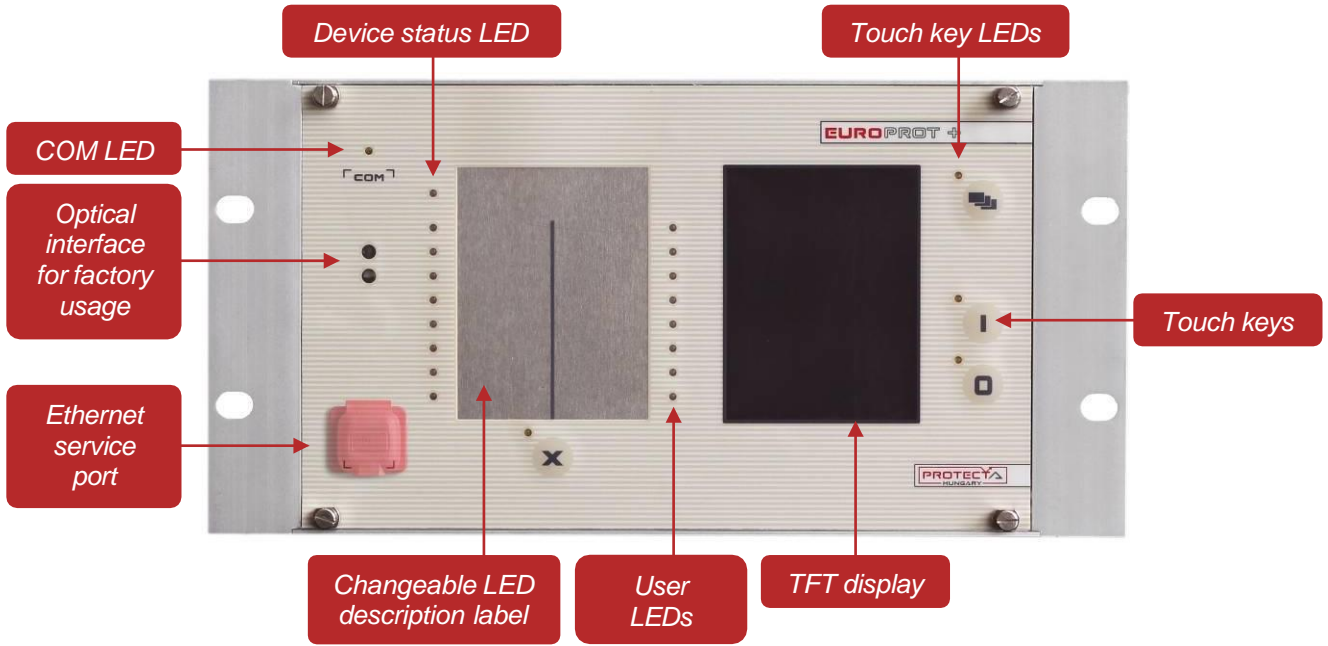

Figure 4–3 HMI signals and controls

LCD dot-defect handling policy

The definitions of dot-defect are as below:

- The defect area of the dot must be bigger than half of a dot.
- For bright dot-defect (sparkle mode), showing black pattern, the dot's brightness must be over 30 % brighter than others at black raster.
- For dark dot-defect (black mode), showing white pattern, the dot's brightness must be under 70 % darker than others at R.G.B. raster.

DOT-DEFECT TYPE		MAXIMUM NUMBER ACCEPTABLE	
		3.5"	5.7"
SPARKLE MODE	1 dot	4	4
	2 dots	2 (sets)	1
	IN TOTAL	4	5
BLACK MODE	1 dot	4	5
	2 dots	2 (sets)	2
	IN TOTAL	4	5
SPARKLE MODE AND BLACK MODE	2 dots	2 (sets)	n/a
IN TOTAL		6	10

For further information please contact our Application Team. (application@protecta.hu)

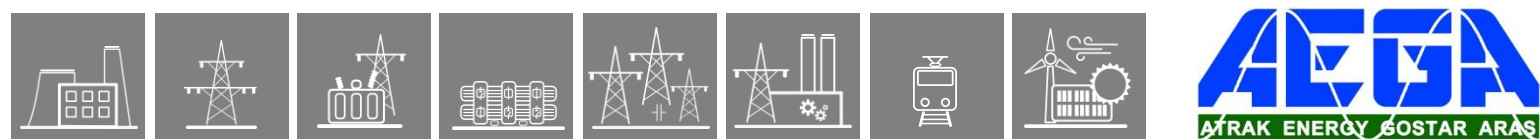

1.3.7. Current input module

This is an input module with intermediate current transformers to input the phase currents and the zero-sequence current. The rated current for the phase current and for the zero-sequence current can be selectable by parameter.

Main features:

- Rated frequency: 50 Hz, 60 Hz
- *Electronic* iron-core flux compensation

Connector types:

- *The default and optionally available connector types are indicated for each module in the tables below. See Chapter 20.2 for details about each type.*

MODULE TYPE	CT+/0101		CT+/1111*		CT+/1155		CT+/1500	
CHANNEL NUMBER	1 – 4		1 – 4		1 – 4		1 – 3	
SELECTABLE RATED CURRENT, I_N [A]	0.04	0.2	1	5	1	5	1	5
MAX. MEASURED CURRENT ($\pm 10\%$)	$8 \times I_N$		$50 \times I_N$		$12.5 \times I_N$		$2 \times I_N$	
POWER CONSUMPTION AT RATED CURRENT [VA]	0.005	0.1	0.01	0.25	0.02	0.45	0.1	1.55
THERMAL WITHSTAND [A]								
CONTINUOUSLY	7		20		20		7	
10 s	50		175		120		50	
1 s	150		500		380		150	
10 ms	330		1200		850		330	
CONNECTOR TYPE	<u>Default:</u> STVS <u>Options:</u> -		<u>Default:</u> STVS <u>Options:</u> -		<u>Default:</u> STVS <u>Options:</u> -		<u>Default:</u> STVS <u>Options:</u> R	
RECOMMENDED APPLICATION	DEFL earth fault protection		Special disturbance recorder application in wider frequency range		Special protection applications where the overcurrent in the secondary circuit can not exceed $10 \times I_N$		General three-phase measurement	

***Obsolete module. These modules are not recommended for new designs!**

MODULE TYPE	CT+/1515*		CT+/2500*		CT+/5101			
CHANNEL NUMBER	1 – 4		1 – 3		1 – 3		4	
SELECTABLE RATED CURRENT, I_N [A]	1	5	1	5	1	5	0.2	1
MAX. MEASURED CURRENT ($\pm 10\%$)	$2 \times I_N$		$2 \times I_N$		$50 \times I_N$		$12.5 \times I_N$	
POWER CONSUMPTION AT RATED CURRENT [VA]	0.1	1.55	0.1	1.55	0.01	0.25	0.005	0.1
THERMAL WITHSTAND [A]								
CONTINUOUSLY	7		7		20		7	
10 s	50		50		175		50	
1 s	150		150		500		150	
10 ms	330		330		1200		330	
CONNECTOR TYPE	<u>Default:</u> STVS <u>Options:</u> -		<u>Default:</u> STVS <u>Options:</u> -		<u>Default:</u> STVS <u>Options:</u> -			
RECOMMENDED APPLICATION	Special disturbance recorder application		Generator protections		Extremely sensitive earth-fault applications			

***Obsolete module. These modules are not recommended for new designs!**

MODULE TYPE	CT+/5102				CT+/5111*			
CHANNEL NUMBER	1 – 3		4		1 – 3		4	
SELECTABLE RATED CURRENT, I_N [A]	1	5	0.2	1	1	5	0.001	0.005
MAX. MEASURED CURRENT ($\pm 10\%$)	$50 \times I_N$		$50 \times I_N$		$50 \times I_N$		$50 \times I_N$	
POWER CONSUMPTION AT RATED CURRENT [VA]	0.01	0.25	0.001	0.01	0.01	0.25	0.005	0.1
THERMAL WITHSTAND [A]								
CONTINUOUSLY	20		20		20		7	
10 s	175		120		175		50	
1 s	500		380		500		150	
10 ms	1200		850		1200		330	
CONNECTOR TYPE	<u>Default:</u> STVS <u>Options:</u> -				<u>Default:</u> STVS <u>Options:</u> R			
RECOMMENDED APPLICATION	Sensitive earth-fault applications				Sensitive earth-fault applications			

***Obsolete module. These modules are not recommended for new designs!**

MODULE TYPE	CT+5115		CT+5116		CT+/5151		CT+/5152	
CHANNEL NUMBER	1 – 4		1 – 3		1 – 4		1 – 4	
SELECTABLE RATED CURRENT, I_N [A]	1	5	1	5	1	5	1	5
MAX. MEASURED CURRENT ($\pm 10\%$)	$50 \times I_N$		$50 \times I_N$		$50 I_N$		$50 I_N$	
POWER CONSUMPTION AT RATED CURRENT [VA]	0.01	0.25	0.01	0.25	0.01	0.25	0.01	0.25
THERMAL WITHSTAND [A]								
CONTINUOUSLY	20		20		20		20	
10 s	175		175		175		175	
1 s	500		500		500		500	
10 ms	1200		1200		1200		1200	
CONNECTOR TYPE	<u>Default:</u> STVS <u>Options:</u> R		<u>Default:</u> STVS <u>Options:</u> -		<u>Default:</u> STVS <u>Options:</u> R		<u>Default:</u> STVS <u>Options:</u> R	
RECOMMENDED APPLICATION	<ul style="list-style-type: none"> General protection applications* Three-phase measurement* 		High-impedance differential protection		General protection applications		Busbar protection bay units	

*The CT+/5115 module handles both applications: it can be connected to the protection and measurement core of the primary CT as well

MODULE TYPE	CT+/5153					CT+/5154*				
CHANNEL NUMBER	1 – 3		4			1 – 3		4		
SELECTABLE RATED CURRENT, I_N [A]	1	5	1	0.2	0.2 sens.	1	5	5	1	0.2
MAX. MEASURED CURRENT ($\pm 10\%$)	$50 \times I_N$			$10 \times I_N$		$50 \times I_N$			$10 \times I_N$	
POWER CONSUMPTION AT RATED CURRENT [VA]	0.06	1.3	0.6	0.004	0.0004	0.06	1.3	1.3	0.06	0.004
THERMAL WITHSTAND [A]										
CONTINUOUSLY	20		7			20				
10 s	175		50			175				
1 s	500		150			500				
10 ms	1200		330			1200				
CONNECTOR TYPE	<u>Default:</u> STVS <u>Options:</u> R, T**					<u>Default:</u> STVS <u>Options:</u> R				
RECOMMENDED APPLICATION	General protection application, extremely sensitive transient earth-fault protections					General protection application, sensitive transient earth-fault protections				

***Obsolete module. These modules are not recommended for new designs!**

**The connector remains the same STVS, only the handle of the module becomes narrower and will be made of aluminum

MODULE TYPE	CT+/5155*					CT+/5253**				
CHANNEL NUMBER	1 – 3		4			1 – 3		4		
SELECTABLE RATED CURRENT, I_N [A]	1	5	0.25	0.05	0.05 sens.	5	1	0.25	0.05	0.05 sens.
MAX. MEASURED CURRENT ($\pm 10\%$)	$50 \times I_N$			$10 \times I_N$		$25 \times I_N$				
POWER CONSUMPTION AT RATED CURRENT [VA]	0.06	1.3	0.6	0.004	0.0004	0.06	1.3	0.6	0.004	0.0004
THERMAL WITHSTAND [A]										
CONTINUOUSLY	20		7			20		7		
10 s	175		50			175		50		
1 s	500		150			500		150		
10 ms	1200		330			1200		330		
CONNECTOR TYPE	Default: STVS Options: -					Default: STVS Options: -				
RECOMMENDED APPLICATION	DMD Special sensitive earth fault protection					Circuit breaker diagnostics				

***Obsolete module. These modules are not recommended for new designs!**

****Special module**

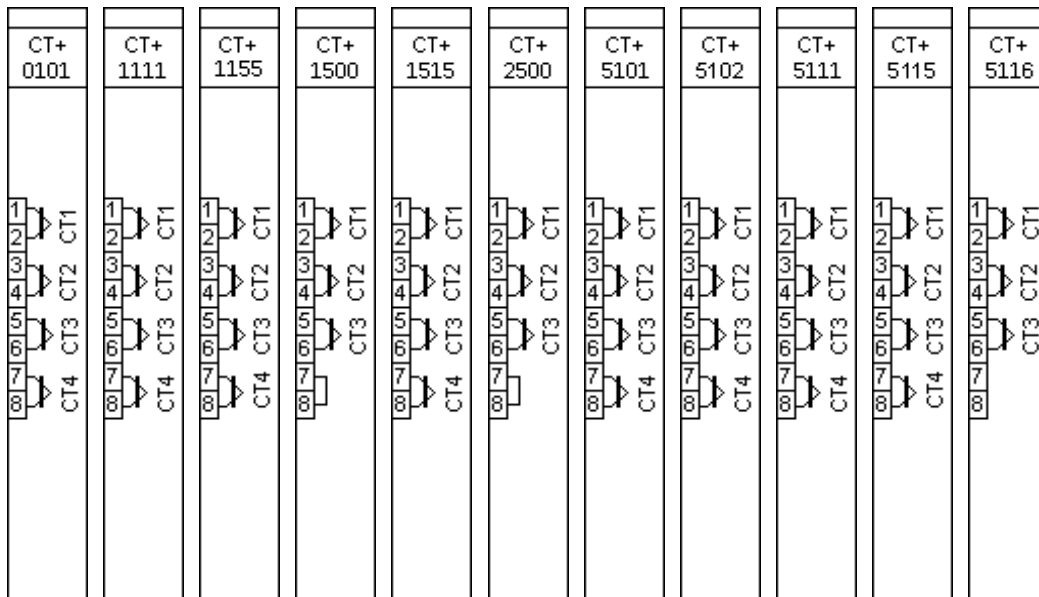

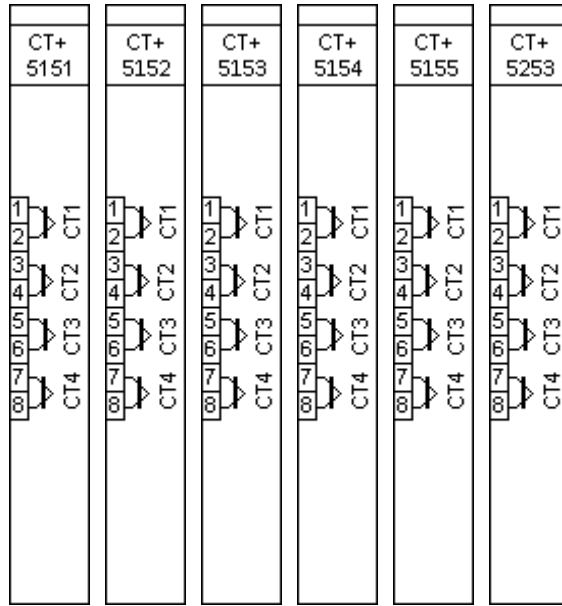
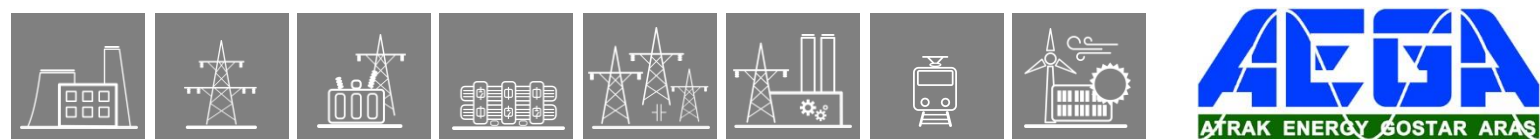

Figure 5-1 CT modules



1.3.8. Voltage input module

If the device performs voltage and/or frequency related functions and measurements (voltage protections, directional protections, frequency protections etc.), then this module is needed.

Connector types:

- The default and optionally available connector types are indicated for each module in the tables below. See Chapter 20.2 for details about each type.

MODULE TYPE	VT+/2211	VT+/2212*	VT+/2215**
CHANNEL NUMBER	4	4	4
SELECTABLE VOLTAGE RANGE	<u>Type 100:</u> $\frac{100}{\sqrt{3}}$, 100 V <u>Type 200:</u> $\frac{200}{\sqrt{3}}$, 200 V	<u>Type 100:</u> $\frac{100}{\sqrt{3}}$, 100 V <u>Type 200:</u> $\frac{200}{\sqrt{3}}$, 200 V	<u>Type 100:</u> $\frac{100}{\sqrt{3}}$, 100 V <u>Type 200:</u> $\frac{200}{\sqrt{3}}$, 200 V
CONTINUOUS VOLTAGE WITHSTAND	200 V	200 V	200 V
SHORT TIME OVERLOAD (1 s)	275 V (10s)	275 V	275 V
VOLTAGE MEASURING RANGE ($\pm 10\%$)	$0.05 U_N - 1.3 U_N$	$0.05 U_N - 1.3 U_N$	$0.05 U_N - 1.3 U_N$
POWER CONSUMPTION OF VOLTAGE INPUT	0.61 VA at 200 V 0.2 VA at 100 V	0.61 VA at 200 V 0.2 VA at 100 V	<u>ch. 1-3:</u> 0.61 VA at 200 V 0.2 VA at 100 V <u>ch. 4:</u> 50 mVA at 100 V
CONNECTOR TYPE	<u>Default:</u> BLA <u>Options:</u> F, T, R	<u>Default:</u> BLA <u>Options:</u> -	<u>Default:</u> BLA <u>Options:</u> -
RECOMMENDED APPLICATION	General protection applications.	Special disturbance recorder application in wider frequency range	Special protection applications with voltage transformers that require low power consumption on the 4 th channel.

***Obsolete module. These modules are not recommended for new designs!**

**Special module

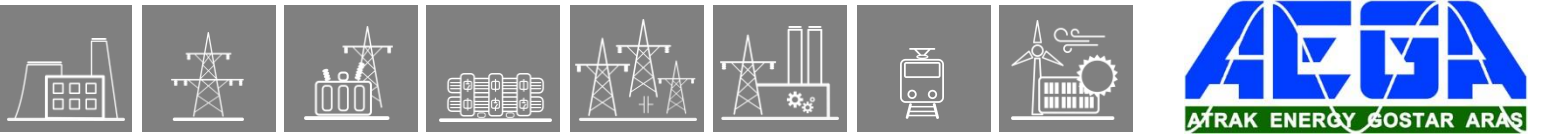

MODULE TYPE	VT+/2245	VT+/2246*
CHANNEL NUMBER	4	3
SELECTABLE VOLTAGE RANGE	Type 200: $\frac{200}{\sqrt{3}}$, 200 V Type 400: $\frac{400}{\sqrt{3}}$	
CONTINUOUS VOLTAGE WITHSTAND	400 V	
SHORT TIME OVERLOAD (1 s)	420 V	420 V (10 s)
VOLTAGE MEASURING RANGE ($\pm 10\%$)	0.05 U _N – 1.3 U _N	
POWER CONSUMPTION OF VOLTAGE INPUT	0.21 VA at 200 V 0.28 VA at 230 V	
CONNECTOR TYPE	Default: BLA Options: T	Default: BLA Options: -
RECOMMENDED APPLICATION	Protection applications for 400 V AC secondary voltage	Special protection applications for 400 V AC secondary voltage and increased isolation to 6 kV

*Special module

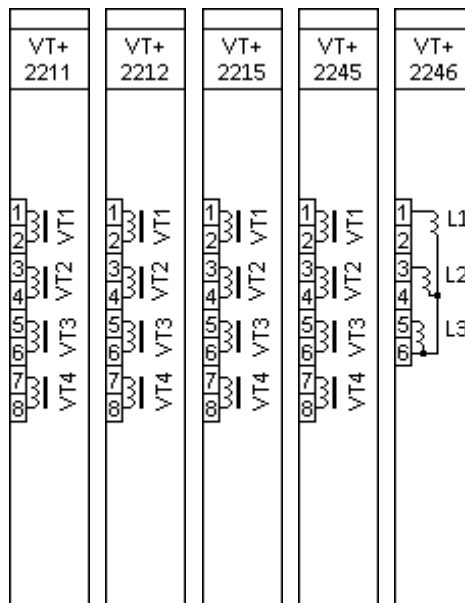
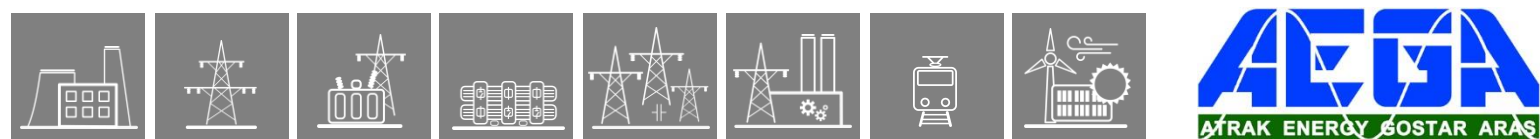

Figure 6-1 VT modules



1.3.9. Binary input module

The inputs are galvanic isolated, and the module converts high-voltage signals to the voltage level and format of the internal circuits. The inputs of this module can be also programmed to serve as a PPM input for time synchronization.

Connector types:

- The default and optionally available connector types are indicated for each module in the tables below. See Chapter 20.2 for details about each type.

Notes for the following tables:

- **Thermal withstand voltage:** continuous with 60 % of the input channels are energized.
- **Clamp voltage:** these are the guaranteed values; the actual ones might differ from those provided here (falling and rising around $0.66 U_N$ and $0.77 U_N$, respectively)

MODULE TYPE	O8+/2401	O8+/4801	O8+/1101	O8+/2201
CHANNEL NUMBER	8	8	8	8
TIME SYNCHRONIZATION	configured by EuroCAP	configured by EuroCAP	configured by EuroCAP	configured by EuroCAP
RATED VOLTAGE	24 V	48 V	110 V	220 V
THERMAL WITHSTAND VOLTAGE	72 V	100 V	250 V	320 V
CLAMP VOLTAGE	falling $0.64 U_N$ rising $0.8 U_N$	falling $0.64 U_N$ rising $0.8 U_N$	falling $0.64 U_N$ rising $0.8 U_N$	falling $0.64 U_N$ rising $0.8 U_N$
COMMON GROUPS	independent	independent	independent	independent
CONNECTOR TYPE	<u>Default:</u> BLA <u>Options:</u> T	<u>Default:</u> BLA <u>Options:</u> T	<u>Default:</u> BLA <u>Options:</u> T	<u>Default:</u> BLA <u>Options:</u> T

MODULE TYPE	O12+/2401	O12+/4801	O12+/1101	O12+/2201
CHANNEL NUMBER	12	12	12	12
TIME SYNCHRONIZATION	configured by EuroCAP	configured by EuroCAP	configured by EuroCAP	configured by EuroCAP
RATED VOLTAGE	24 V	48 V	110 V	220 V
THERMAL WITHSTAND VOLTAGE	72 V	72 V	250 V	320 V
CLAMP VOLTAGE	falling $0.64 U_N$ rising $0.8 U_N$	falling $0.64 U_N$ rising $0.8 U_N$	falling $0.64 U_N$ rising $0.8 U_N$	falling $0.64 U_N$ rising $0.8 U_N$
COMMON GROUPS	4 × 3 common	4 × 3 common	4 × 3 common	4 × 3 common
CONNECTOR TYPE	<u>Default:</u> BLA <u>Options:</u> T	<u>Default:</u> BLA <u>Options:</u> F, T	<u>Default:</u> BLA <u>Options:</u> F, T	<u>Default:</u> BLA <u>Options:</u> T

MODULE TYPE	O12+/4201*	O12+/2101*	O15+/4801T	O15+/1101T
CHANNEL NUMBER	12	12	15	15
TIME SYNCHRONIZATION	configured by EuroCAP	configured by EuroCAP	configured by EuroCAP	configured by EuroCAP
RATED VOLTAGE	24 V DC / 48 V DC user selectable on channel basis by jumpers	110 V DC / 220 V DC user selectable on channel basis by jumpers	48 V	110 V
THERMAL WITHSTAND VOLTAGE	72 V	320 V	100 V	250 V
CLAMP VOLTAGE	falling 0.64 U _N rising 0.8 U _N	falling 0.64 U _N rising 0.8 U _N	falling 0.64 U _N rising 0.8 U _N	falling 0.64 U _N rising 0.8 U _N
COMMON GROUPS	4 × 3 common	4 × 3 common	1 × 15 common	1 × 15 common
CONNECTOR TYPE	<u>Default:</u> BLA <u>Options:</u> -	<u>Default:</u> BLA <u>Options:</u> T	BLT	BLT

* O12+2101 and O12+4201 modules can be used only in demonstration applications! For further information see our [Product availability](#) chapter.

MODULE TYPE	O16+/2401*	O16+/4801*	O16+/1101*	O16+/2201*
CHANNEL NUMBER	16	16	16	16
TIME SYNCHRONIZATION	-	-	-	-
RATED VOLTAGE	24 V	48 V	110 V	220 V
THERMAL WITHSTAND VOLTAGE	72 V	100 V	250 V	320 V
CLAMP VOLTAGE	falling 0.64 U _N rising 0.8 U _N	falling 0.64 U _N rising 0.8 U _N	falling 0.64 U _N rising 0.8 U _N	falling 0.64 U _N rising 0.8 U _N
COMMON GROUPS	2 × 8 common	2 × 8 common	2 × 8 common	2 × 8 common
CONNECTOR TYPE	<u>Default:</u> BL 3.5 <u>Options:</u> -	<u>Default:</u> BL 3.5 <u>Options:</u> -	<u>Default:</u> BL 3.5 <u>Options:</u> -	<u>Default:</u> BL 3.5 <u>Options:</u> -

*Obsolete module. These modules are not recommended for new designs! O15+ modules are recommended instead (see above).

Main features:

- Digitally filtered per channel
- Current drain:
 - max. 1.6 mA per channel at 220 V DC
 - max. 1.8 mA per channel at 110 V DC
 - max. 2 mA per channel at 48 V DC
 - max. 3 mA per channel at 24 V DC
- In such applications where the input voltage is 60 V the modules with 48 V rated voltage can be used.
- Input voltage type can be either DC or AC voltage. If AC voltage is used make sure that the type and the parameters of the binary inputs are configured properly in EuroCAP tool.

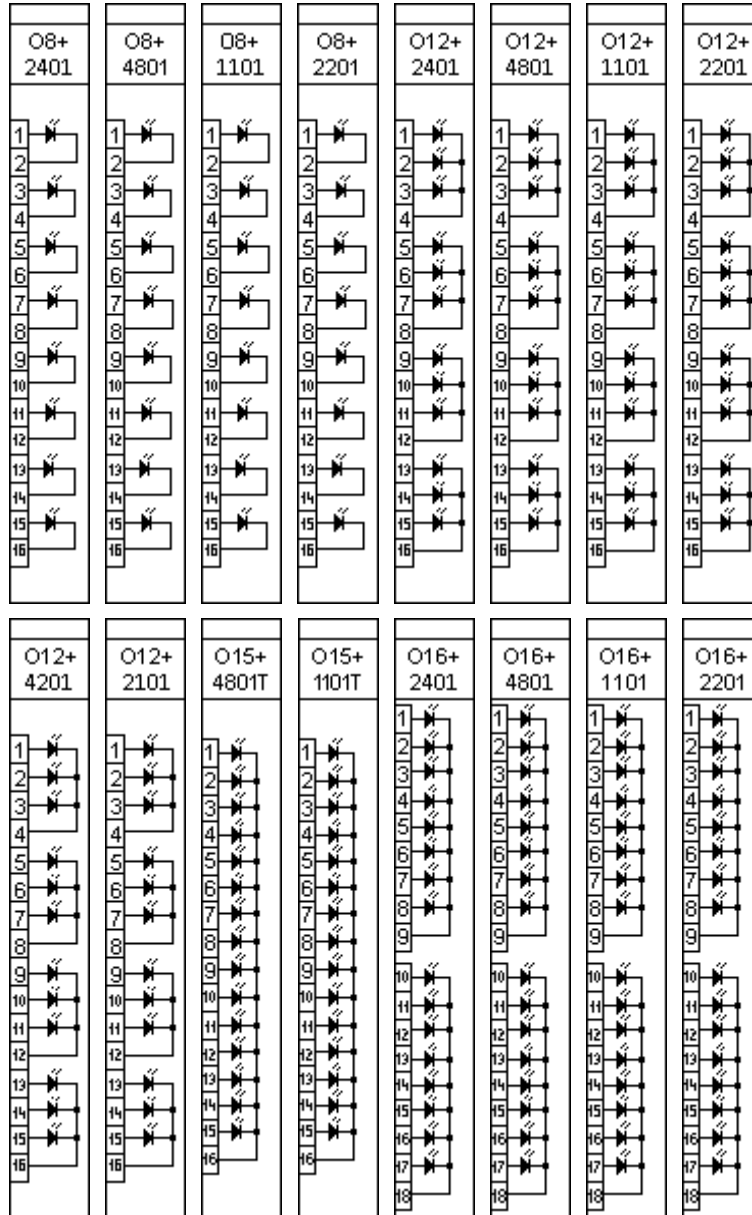

Figure 7-1 Binary input modules

1.3.10. Signaling module

The signaling module has 4, 8, 12 or 16 relay outputs with dry contacts.

Connector types:

- The default and optionally available connector types are indicated for each module in the tables below. See Chapter 20.2 for details about each type.

MODULE TYPE	R4+/01	R8+/00	R8+/80	R8+/C0
RATED VOLTAGE	250 V AC/DC	250 V AC/DC	250 V AC/DC	250 V AC/DC
CONTINUOUS CARRY	8 A	8 A	8 A	8 A
CONTACT VERSIONS	4 CO	8 NO	CH8 NC others NO	CH7 and CH8 NC others NO
GROUP ISOLATION	4 independent	8 independent	8 independent	8 independent
CONNECTOR TYPE	<u>Default:</u> BLA <u>Options:</u> F	<u>Default:</u> BLA <u>Options:</u> F, T	<u>Default:</u> BLA <u>Options:</u> T	<u>Default:</u> BLA <u>Options:</u> T

MODULE TYPE	R8+/FF	R12+/0000	R12+/4000
RATED VOLTAGE	250 V AC/DC	250 V AC/DC	250 V AC/DC
CONTINUOUS CARRY	8 A	8 A	8 A
CONTACT VERSIONS	8 NC	12 NO	CH12 NC others NO
GROUP ISOLATION	8 independent	4 × 3 common	4 × 3 common
CONNECTOR TYPE	<u>Default:</u> BLA <u>Options:</u> -	<u>Default:</u> BLA <u>Options:</u> F, T	<u>Default:</u> BLA <u>Options:</u> F, T

MODULE TYPE	R16+/0000	R16+/8000	R16+/8080
RATED VOLTAGE	250 V AC/DC	250 V AC/DC	250 V AC/DC
CONTINUOUS CARRY	8 A	8 A	8 A
CONTACT VERSIONS	16 NO	CH16 NC others NO	CH16 and CH8 NC others NO
GROUP ISOLATION	2 × 8 common	2 × 8 common	2 × 8 common
CONNECTOR TYPE	<u>Default:</u> BLA <u>Options:</u> -	<u>Default:</u> BLA <u>Options:</u> -	<u>Default:</u> BLA <u>Options:</u> -

MODULE TYPE	R4S+/01*	R4S+/16*	R1T+/0001***
RATED VOLTAGE	250 V AC/DC	250 V AC/DC	320 V AC/DC
CONTINUOUS CARRY	8 A 120 mA**	120 mA	32 A
CONTACT VERSIONS	4 CO (1 SSR, 3 normal)	4 CO (4 SSR)	1 NO
GROUP ISOLATION	4 independent	4 independent	1 independent
CONNECTOR TYPE	<u>Default:</u> BLA <u>Options:</u> -	<u>Default:</u> BLA <u>Options:</u> -	<u>Default:</u> BLA <u>Options:</u> -

*Modules with **solid-state relays (SSR)**

**If the signaling is performed via the solid-state relay the continuous carry value is 120 mA.

*****Thyristor module**. Can be used only unipolarly. For further information see our [Product availability chapter](#).

Main features (according to IEC 60255-1):

- Maximum switching voltage: 400 V AC
- Breaking capacity: (L/R=40 ms) at 220 V DC: 0.2 A, at 110 V DC: 0.3 A
- Breaking capacity max.: 2000 VA
- Short time carrying capacity: 1 s, 35 A
- Limiting making current, max. 4 s: 15 A (df = 10 %)
- Dielectric strength between open contacts, 1 min: 1000 V_{RMS}
- Mechanical endurance: 10 × 10⁶ cycles
- Circuit closing capability: typically 10 ms, maximally 22 ms, with SSR 0.5 ms.
- Bounce time: typically 6,5 ms, maximally 10 ms, with SSR 0.5 ms.
- Minimal switching requirement: 5 V
- *The signaling is also performed via a solid-state relay (SSR) channel on R4S+01 and R4S+16 module*

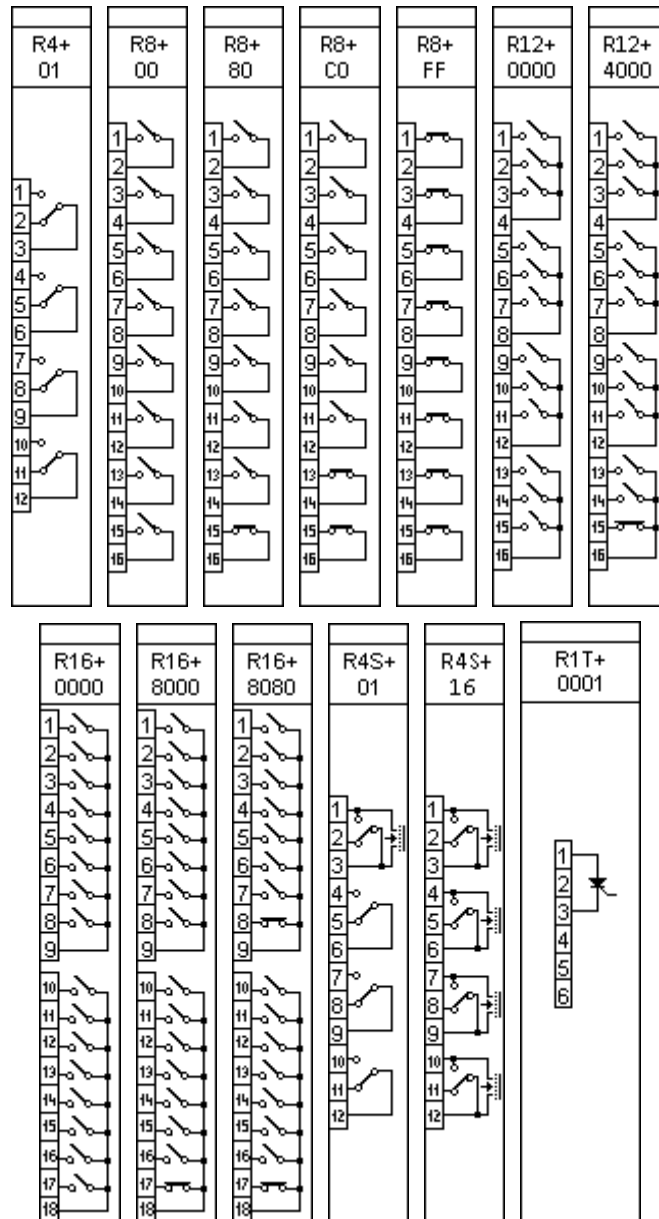

Figure 8-1 Signaling modules

1.3.11. Tripping module

The tripping module is a proprietary and patented solution that facilitates direct control of a circuit breaker.

Connector types:

- The default and optionally available connector types are indicated for each module in the table below. See Chapter 20.2 for details about each type.

MODULE TYPE	TRIP+/4201	TRIP+1101*	TRIP+/2101	TRIP+/21F1**	TRIP+/2201
CHANNEL NUMBER	4	4	4	4	4
RATED VOLTAGE	24 V DC and 48 V DC	110 V DC	110 V DC	110 V DC	220 V DC
THERMAL WITHSTAND VOLTAGE	72 V DC	242 V DC	150 V DC	150 V DC	242 V DC
CONTINUOUS CARRY	8 A	8 A	8 A	8 A	8 A
MAKING CAPACITY	0.5 s, 30 A	0.5 s, 30 A	0.5 s, 30 A	0.5 s, 30 A	0.5 s, 30 A
BREAKING CAPACITY	L/R = 40 ms: 4 A DC	L/R = 40 ms: 4 A DC	L/R = 40 ms: 4 A DC	L/R = 40 ms: 4 A DC	L/R = 40 ms: 4 A DC
CONNECTOR TYPE	<u>Default:</u> BLA <u>Options:</u> F, T	<u>Default:</u> BLA <u>Options:</u> -	<u>Default:</u> BLA <u>Options:</u> F, T	<u>Default:</u> BLA <u>Options:</u> T	<u>Default:</u> BLA <u>Options:</u> T

***Obsolete module. These modules are not recommended for new designs!**

****Without trip circuit supervision.**

Main features:

- High-speed operation: with pre-trip 0.5 ms, without pre-trip typically 10 ms, maximally 22 ms.
- Trip circuit supervision for each trip contact, except TRIP+21F1
- With 2-wire wiring, the tripping output can be *dry* contact type, too

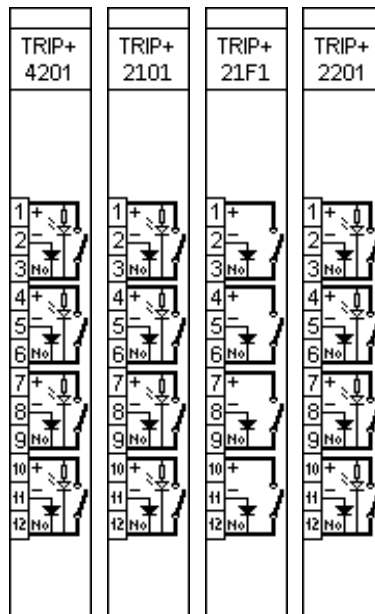

Figure 9-1 Tripping modules

1.3.11.1. TRIP+ module wiring

The tripping module provides tripping circuit supervision function (TCS). The wiring of these modules can be 2-wire or 3-wire. (TCS function is active for all wiring methods.)

The voltage of the "No" contact is maximized at 15 V by a Zener-diode. Make sure that the voltage caused by the resistance of the circuit breaker and the injected current from the TRIP+ module does not reach 10 V.

Our TRIP+ modules are improved to switch DC circuits. **Using reversed polarity or AC voltage can cause the damage of the internal circuits. Improper wiring might cause improper operation!**

1.3.11.1.1. 3-wire TRIP+ wiring methods

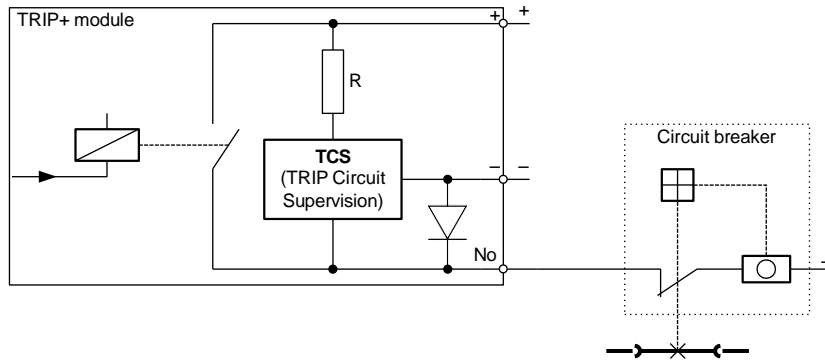

Figure 9-2 3-wire TRIP+ wiring

It is possible to use parallel connected TRIP+ modules. In this case the negative terminals must be common.

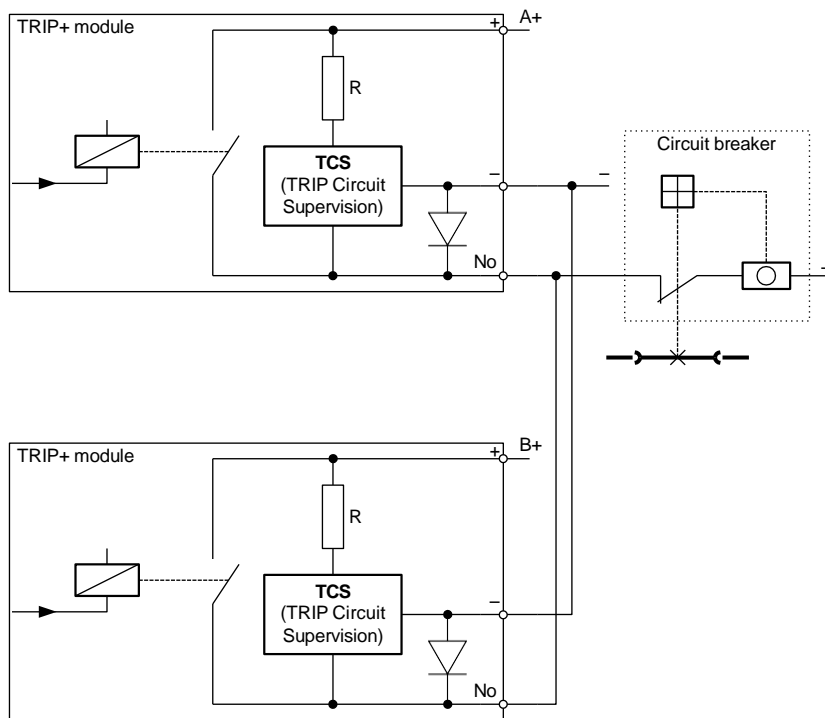

Figure 9-3 3-wire TRIP+ wiring using parallel connected TRIP+ modules

1.3.11.1.2. 2-wire TRIP+ wiring methods

If necessary, the TRIP+ modules can be wired using only the “+” and the “No” contacts.

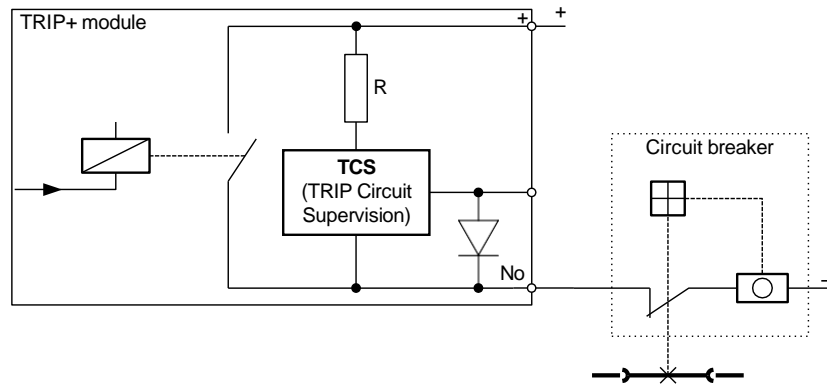

Figure 9-4 2-wire TRIP+ wiring

It is possible to use parallel connected TRIP+ modules.

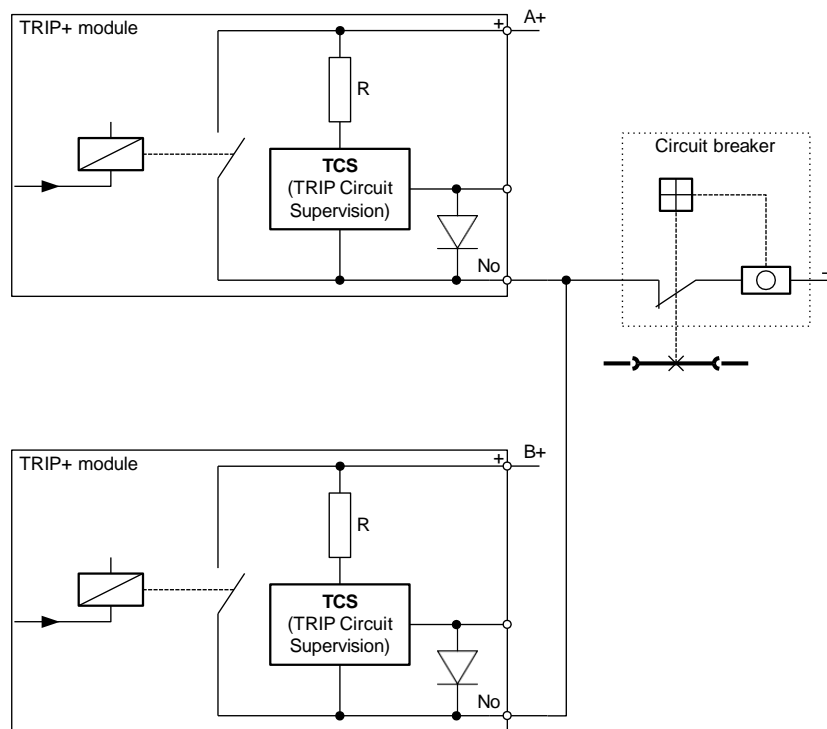

Figure 9-5 2-wire TRIP+ wiring using parallel connected TRIP+ modules

If the circuit breaker needs two-pole switching TRIP+ modules can be connected series as you can see in Figure 9–6.

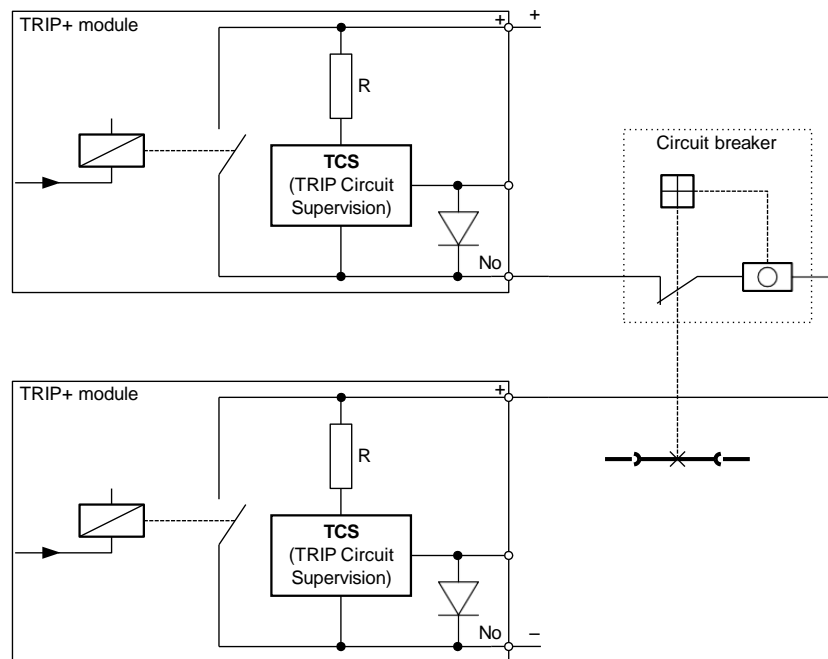

Figure 9-6 2-wire TRIP+ wiring using series connected TRIP+ modules

1.3.11.2. Trip Circuit Supervision (TCS)

Apart from the TRIP+/21F1, all TRIP modules have TCS. The feature is described in detail (tech. data, instructions, etc.) in a separate document:
https://www.protecta.hu/downloads/tcs_en

The technical data of the TCS is shown here as well:

	MODULE TYPE	TRIP+/4201	TRIP+/2101	TRIP+/2201
	VALUE OF R RESISTOR ($\pm 10\%$)	10 k Ω	73 k Ω	130 k Ω
	INJECTED CURRENT AT "NO" CONTACT	2.4 mA @ 24 V DC 4.8 mA @ 48 V DC	1.5 mA @ 110 V DC	1.7 mA @ 220 V DC
MAXIMUM RESISTANCE OF THE TRIP COIL	3-WIRE WIRING (MAX. 10 V)	11.8 k Ω @ 24 V DC 3.7 k Ω @ 48 V DC	9.7 k Ω @ 110 V DC 8.4 k Ω @ 125 V DC	8.1 k Ω @ 220 V DC
	3-WIRE WIRING WITH IN PARALLEL (MAX. 10 V)	5.9 k Ω @ 24 V DC 1.8 k Ω @ 48 V DC	4.8 k Ω @ 110 V DC 4.2 k Ω @ 125 V DC	4 k Ω @ 220 V DC
	2-WIRE METHOD (1 mA MIN. CURRENT)	14 k Ω @ 24 V DC 38 k Ω @ 48 V DC	37 k Ω @ 110 V DC 52 k Ω @ 125 V DC	90 k Ω @ 220 V DC

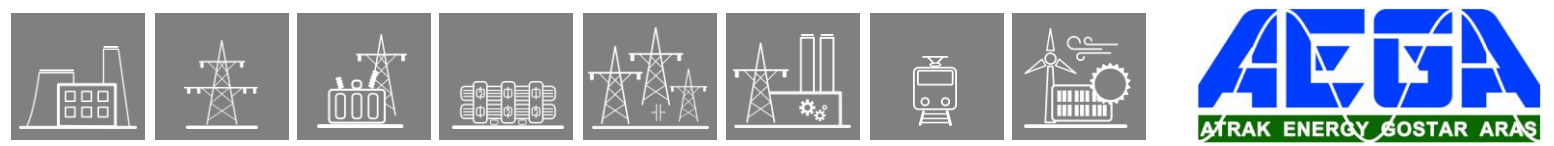

1.3.11.3. Relay output modules of the EuroProt+ system

1.3.11.3.1. Types of the relay output modules of the EuroProt+ system

Basically there are two different types of relay output modules in the EuroProt+ devices: TRIP relay output module for high-speed operation of the circuit breakers Signal relay output module

1.3.11.3.2. Operating modes of the relay contacts

For operation of the relay output modules there are four different modes:

Application of TRIP relays for commands of fast protection functions

User application of the TRIP relays Fast operation of any relay contacts (TRIP relays or signal relays) Control of signal relay outputs.

The procedures of command processing are shown in. This document describes the details using the TRIP relay contacts as an example.

The left side of the Figure shows the available sources of the trip commands:

The functionblocks, configured in the device,

The communication channels to the SCADA system,

Commands generated using the front panel LCD of the device,

Any other binary signals, e.g. signals from the binary inputs of the device.

The right side of the Figure shows one of the TRIP relays symbolically.

The Figure provides a survey of the configured trip command processing methods. In the middle of the Figure, the locations indicated by "User" shows the possibilities for the user to modify the procedures. All other parts are factory programmed.

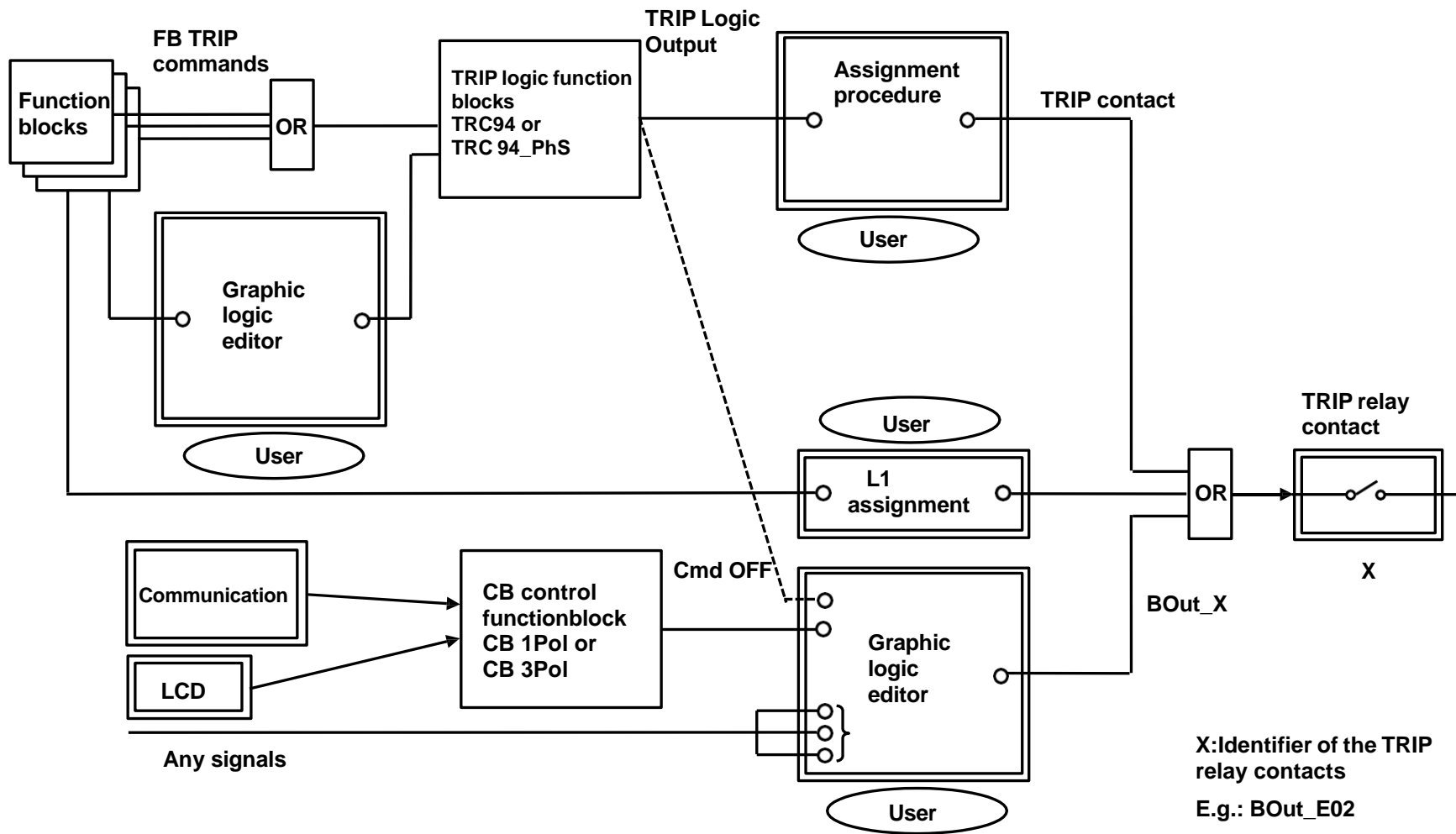

Figure 1-1 Principle of TRIP command processing



1.3.11.3.3. Application of TRIP relays for commands of fast protection functions

1.3.11.3.3.1. Aim of application of TRIP relays

The main aim of application of TRIP relays is to bypass the time delay of the mechanical contacts. For this aim there is a „slow” mechanical contact and a „fast” electronic switch in serial connection.

1.3.11.3.3.2. Control of the TRIP relays

The operation of the TRIP relays is performed in two steps:
Preparation of the circuit for the trip command
Trip command generation

1.3.11.3.3.2.1. Preparation of the circuit for the trip command

At the time when a protection function detects violation of the setting value of the characteristic quantity, the preparation process closes the „slow” mechanical contact, preparing the circuit for command generation.

1.3.11.3.3.2.2. The trip command generation

At the moment when the fast protection function – after some repeated checks, i.e. the timeout of the internal time counter – decides to generate the trip command then the „fast” electronic switch performs the operation, generating the trip command to the circuit breaker. This command is generated via the „TRC94_ PhS” or via the simplified „TRC94” trip logic functionblocks.

NOTE: If the TRIP command is not received within the expected time delay, then the command preparation resets after 50 ms. When the device is tested in the laboratory e.g. for measuring the limits of the distance protection characteristic, this can result a cyclic closing and opening of the mechanical contact and rattling can be heard. This does not mean faulty operation of the device!

1.3.11.3.3.3. The factory programming for relay control

For the trip command of protection functions, where the requirement is the fast operation (distance protection first zone, line differential protection, transformer differential protection, fast overcurrent stage, synchronous switching, etc.) the process of preparation and command generation is programmed in the form of „Fast logic”.

The alignment of the TRIP command is the task of the “TRIP logic functionblock”. All devices operating with TRIP binary output module, has a configured TRC 94 simplified, or a TRC 94_PhS TRIP logic functionblock. This converts e.g. the trip command due to phase-to-phase fault to a three-phase trip command, or extends the duration of the command according to the parameter setting. All these are described in the dedicated document.

The fast TRIP commands are assigned to the TRIP relay output contacts according to the factory configuration, but the user has a possibility to modify or extend this assignment using the EuroCAP configuration software. The factory assignment is described in the user manual of the given device configuration.

To ensure fast operation, this „Fast logic” is performed in each sampling cycle (1ms).

1.3.11.3.3.4. Changing the TRIP command assignment

The user has a possibility to modify or extend the TRIP command assignment using the EuroCAP configuration software. The menu item to be started is shown in *Figure 2-1*.

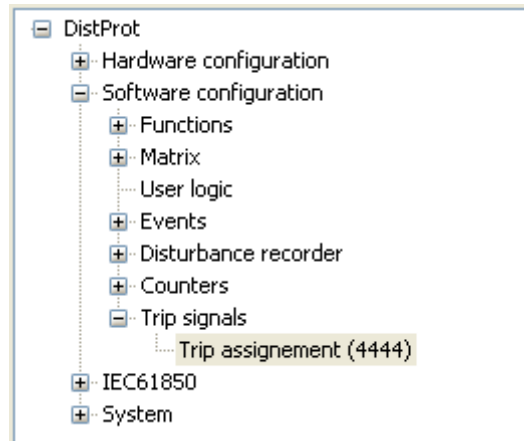

Figure 2-1 Menu item for TRIP command assignment

As *Figure 2-2* shows, the signal of type „TripLogic Output” (this is the command generated by the „TRIP logic functionblock”) can be assigned to a „Trip Contact” type relay output. The dialog window of the EuroCAP software selects these types of signals only; the available signals however can be assigned freely.

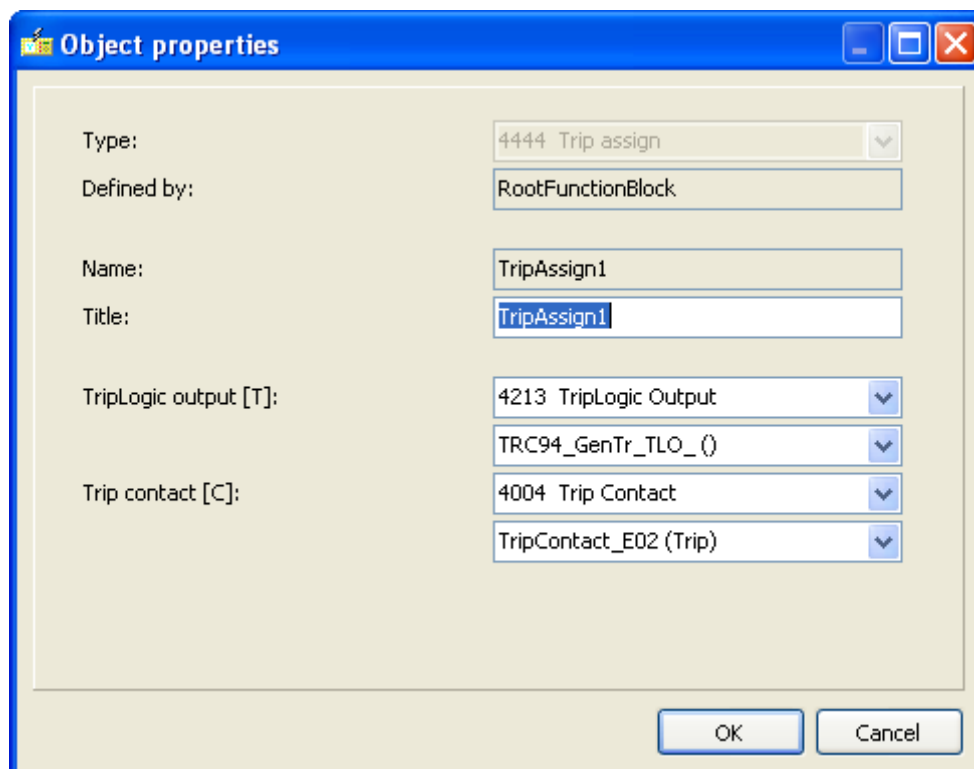

Figure 2-2 Changing the TRIP command assignment

The assigned signal is the input of an OR gate. As it is described below, several other signals can be directed to this OR gate. Using this method, also other TRIP modules extended by the user can be applied to operate the TRIP coil of the circuit breaker.

1.3.11.3.3.5. Fast operation of the relays

If the aim is to operate the contacts by a signal in each sampling cycle (1 ms), then the “Fast L1 contact option is to be applied. This option is provided by the EuroCAP configuration software in the menu „Hardware configuration/ IO signals/ Binary outputs/ Relay contacts/ Fast_L1 contacts”.

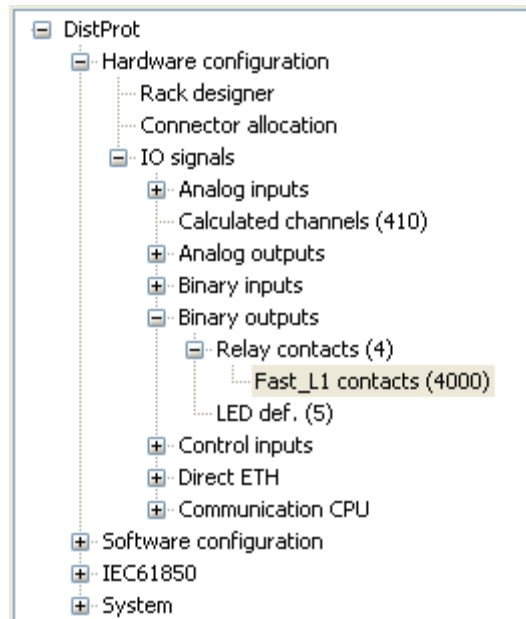

Figure 2-3 Configuring Fast L1 contacts

This menu offers the assignment of the appropriate binary signals to the relay contacts. As *Figure 2-4* shows, the signal can be of several types.

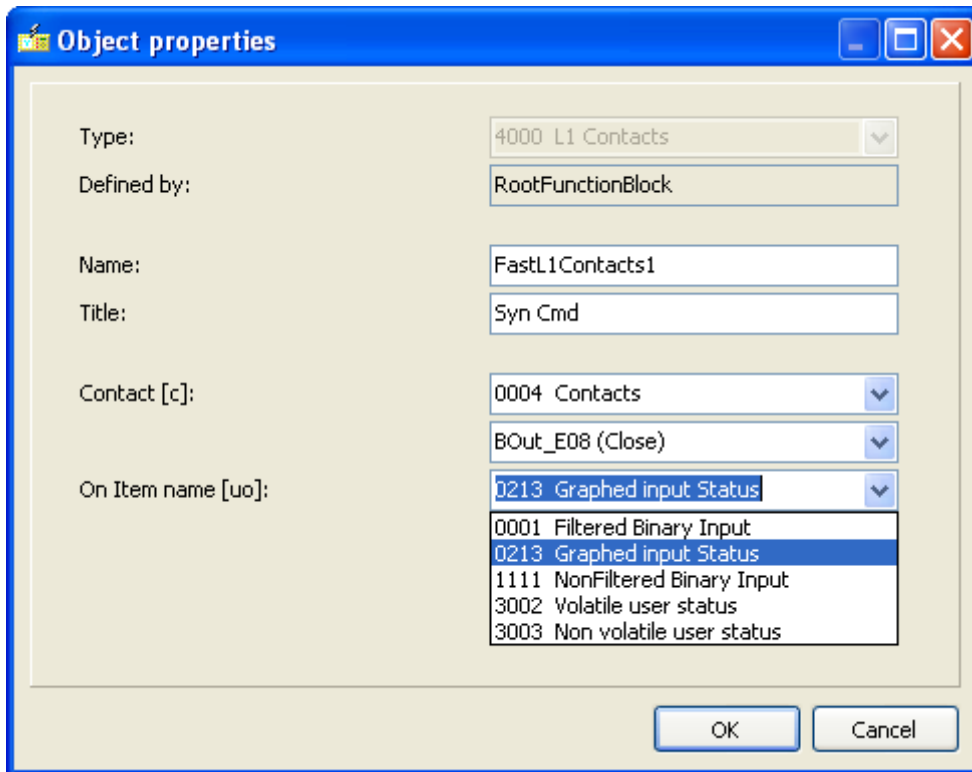

Figure 2-4 Fast L1 contact assignment

The processing of these fast signals is performed in a single step, the possibility for command preparation in the first step and additionally the TRIP command generation in the second step is not offered for the user. To perform this assignment, the application of the EuroCap configuration program in “Master” level is needed.

The selected signal is the input of an OR gate. To this gate additional other signals are connected, as it is described in the previous chapter, or in the description below.

IMPORTANT NOTE: The contacts of a TRIP hardware module are configured in the factory as “Fast L1 contacts”, the user does not need to define them additionally!

1.3.11.3.4. User application of the TRIP relays

The contacts controlling the circuit breaker operation can be programmed also by the user. Additionally to the command of the factory configured protection functions the user can assign signals to the channels of the TRIP hardware module. The two steps for the command generation however, as it is described in the paragraph above, cannot be applied by the user.

In this case, the source of the signals can be:

- Pre-configured TRIP commands
 - Received from the SCADA system via communication channels,
 - Generated by the user, applying the front panel LCD of the device,
- Any additional binary signals, e.g. an external command received by the binary input module of the device.

The pre-configured TRIP commands are aligned by the “CB control functionblock”, the output of which is the “CmdOff” TRIP command. This one and several other

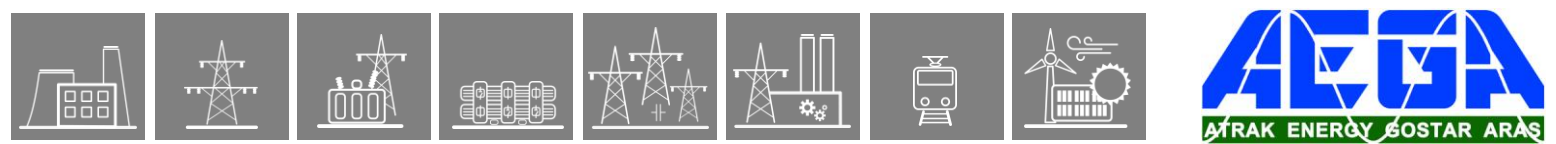

signals can be programmed by the user to the output TRIP contact of the device, using the graphic logic editor of the EuroCAP configuration software.

Additionally the output signals of the „TRC94_PhS” trip logic or those of the „TRC94” simplified trip logic block can be programmed here. (These function-blocks are described in separate documents.) The output signal of the graphic logic editor is the „BOut_X” logic variable, where X is the identifier of the relay module and the contact, e.g. BOut_E02.

1.3.11.3.4.1. Graphic editor for the signal logic

For the protection functions, the operation of which are not required being extreme fast (in the range of one network period), the trip command must be assigned to the trip contacts usually by the user. These logic assignments can be programmed also in the factory, but the user can modify or extend them according to the requirements. To do this, the graphic editor of the EuroCap configuration tool must be applied with „Master” access rights.

1.3.11.3.4.2. The process of command generation

If a “simple” protection function generates a trip command then this logic signal is present on the dedicated output of the functionblock (see the description of the functionblocks).

The operation of the logic connections edited in the graphic editor is performed outside the sampling cycle, consequently, depending on the actual load of the processor a random time delay of additional 2-4 ms can be measured.

The contacts of the TRIP hardware modules are operated by several sources parallel:

- The high-speed factory configured fast protection functions,
- The defined Fast L1 signals,
- The graphically edited logic connections (programmed in the factory and editable also by the user).

1.3.11.3.5. Control of signal relay outputs

If there is no special requirement to generate the signal with high speed, i.e. a time delay of 2-4 ms can be tolerated between the intent to generate the signal and the closing of the output contact then it is sufficient to apply normal signal relay contacts. To perform this programming the graphic editor of the EuroCap configuration tool is to be applied. To perform the programming the „Master” access level is needed.

1.3.11.4. Examples

1.3.11.4.1. Application of the TRIP logic

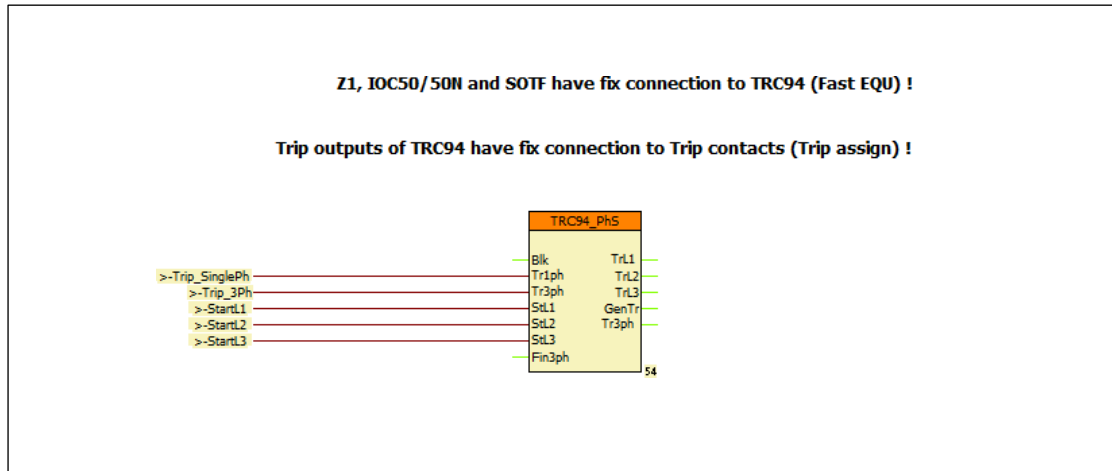

Figure 5-1 Example: A simple configuration to trip the circuit breaker

Figure 5-1 shows a simple configuration to trip the circuit breaker. In this Figure it is supposed that the fast protection functions operate according to the factory configuration and they control the TRIP contacts applying two steps of the preparation and command generation phases. This part of the program is not visible. (The description of the fast operating protection functions are listed in the configuration description of the devices.)

The outputs of the TRC94_PhS trip logic block are assigned to the channels of the TRIP hardware module. This assignment, which can be modified also by the user, is made not here but in the “TRIP assignment” menu of the EuroCAP configuration software. Consequently the Figure is complete; related to the outputs, the user needs additional graphic programming only if e.g. the operation is to be visualized also by signal relays.

If the configuration includes protection functions blocks the trip command of which does not need fast contact operation then these commands must be additionally directed to the TRIP relay outputs. To do this, the user collects these commands (with OR connection) and connects them to the dedicated inputs of the TRC94_PhS functionblock.

This Figure shows the collected signals (E.g. “Trip_SinglePh”, “Trip_3Ph”, etc.) only. As an example the „Trip_3Ph” signal collects the commands of all (not fast operating) protection functions which can generate three-phase trip command. The detailed description of the inputs and operation of the “TRC94_PhS” trip logic functionblock can be found in another document.

1.3.11.4.2. Application of circuit breaker control block

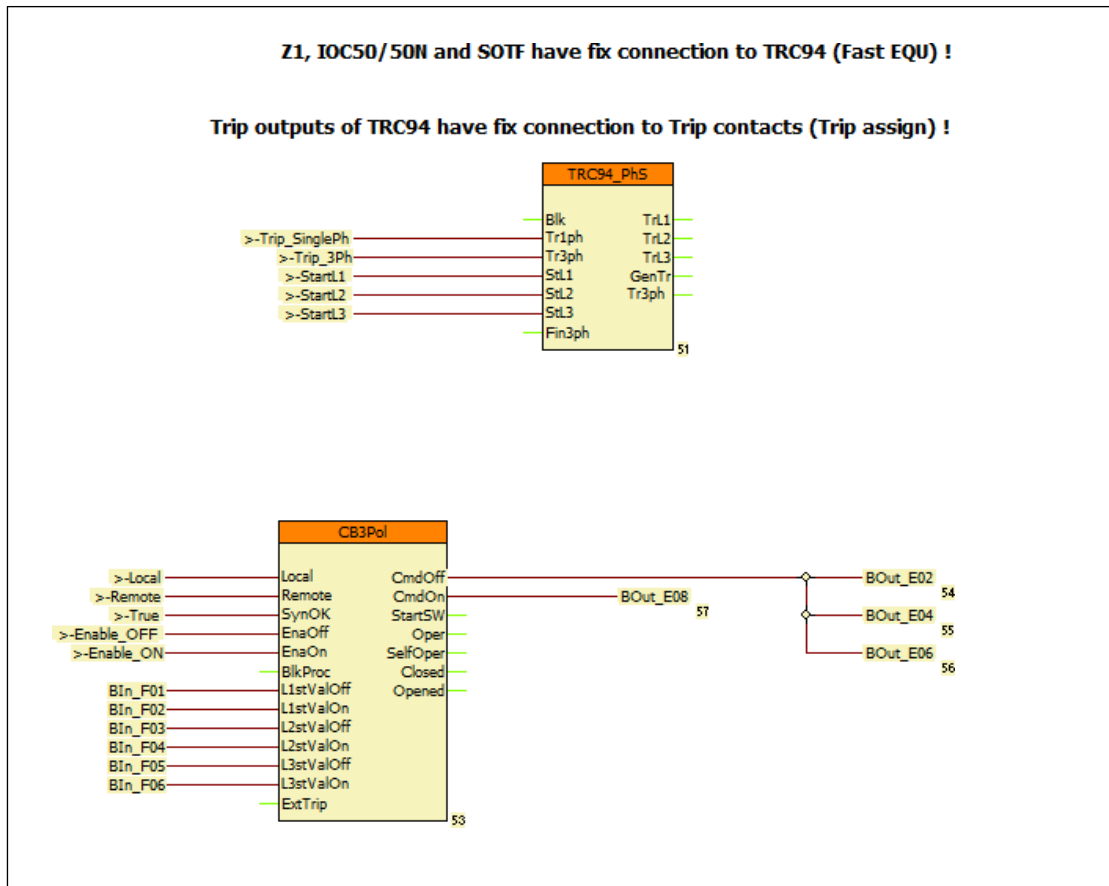

Figure 5-2 Example: Application of circuit breaker control block

Figure 5-2 shows an example for the application of the circuit breaker control block “CB3Pol”. In this Figure it is supposed that the fast protection functions operate according to the factory configuration and they control the TRIP contacts applying two steps of the preparation and command generation phases. This part of the program is not visible. (The description of the fast operating protection functions are listed in the configuration description of the devices.)

The outputs of the TRC94_PhS trip logic block are assigned to the channels of the TRIP hardware module. This assignment, which can be modified also by the user, is made not here but in the “TRIP assignment” menu of the EuroCAP configuration software. Consequently the Figure is complete; related to the outputs, the user needs additional graphic programming only if e.g. the operation is to be visualized also by signal relays.

If the configuration includes protection functions blocks the trip command of which does not need fast contact operation then these commands must be additionally connected to the TRIP relay outputs. To do this, the user collects these commands (with OR connection) and assigns them to the dedicated inputs of the TRC94_PhS functionblock.

This Figure shows the collected signals (E.g. “Trip_SinglePh”, “Trip_3Ph”, etc.) only. As an example the „Trip_3ph” signal collects the commands of all (not fast operating) protection functions which can generate three-phase trip command. The detailed description of the inputs and operation of the “TRC94_PhS” trip logic functionblock can be found in another document.

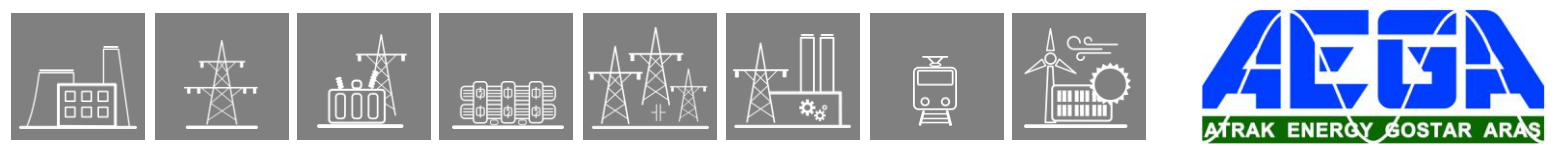

An extension to the example in *Figure 5-2* is that in this configuration also the „CB3pol” (circuit breaker control block) is applied. This block is needed if e.g. the front panel LCD of the device can display an active control scheme. For this purpose the signals „BIn_F...” in the Figure are the status signals of the circuit breaker poles, connected to the dedicated binary inputs of the device. The signals „Local”/”Remote” enable the local or remote control of the primary equipment. In the standard factory configurations these signals are programmed in the factory, but they can be modified also by the user.

If there is no synchro-check function activated in the device, connect the input „SynOK” of the “CB3Pol” to logic TRUE state. *Figure 5-2*, the local command issued via LCD of the device or the remote command received from the remote SCADA system is processed by the „CB3pol” functionblock (Output „CmdOff”). This control is programmed in the factory to “BOut_xx” variables. The user can perform any modification in the graphic programming.

The close command is connected directly to a dedicated “BOut_xx” variable. (This directs usually the fourth contact of the TRIP hardware module.)

The programming of the interlocking function must be performed by the user.

1.3.11.4.3. Automatic reclosing and circuit breaker control

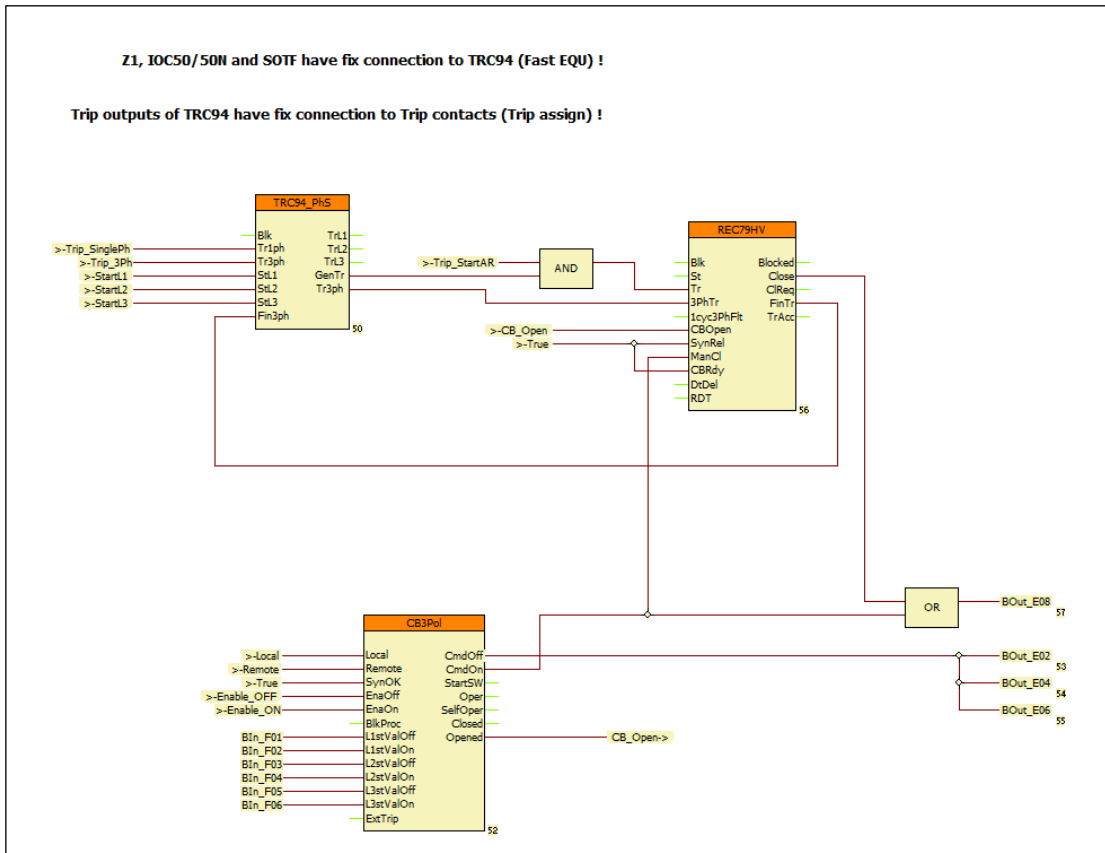

Figure 5-3 Example: Automatic reclosing and circuit breaker control

Figure 5-3 shows an example for the application of the automatic reclosing control block. In this Figure it is supposed that the fast protection functions operate according to the factory configuration and they control the TRIP contacts applying two steps of the preparation and command generation phases. This part of the program is not visible in “Master” level. (The description of the fast operating protection functions are listed in the configuration description of the devices.)

The outputs of the TRC94_PhS trip logic block are assigned to the output channels of the TRIP hardware module. This assignment, which can be modified also by the user, is made not here but in the “TRIP assignment” menu of the EuroCAP configuration software. Consequently the Figure is complete; related to the outputs, the user needs additional graphic programming only if e.g. the operation is to be visualized also by signal relays.

If the configuration includes protection functions blocks the trip command of which does not need fast contact operation then these commands must be additionally assigned to the TRIP relay outputs. To do this, the user collects these commands (with OR connection) and assigns them to the dedicated inputs of the TRC94_PhS functionblock.

This Figure shows the collected signals (E.g. “Trip_SinglePh”, “Trip_3Ph”, etc.) only. As an example the „Trip_3ph” signal collects the commands of all (not fast operating) protection functions which can generate three-phase trip command. The detailed description of the inputs and operation of the “TRC94_PhS” trip logic functionblock can be found in another document.

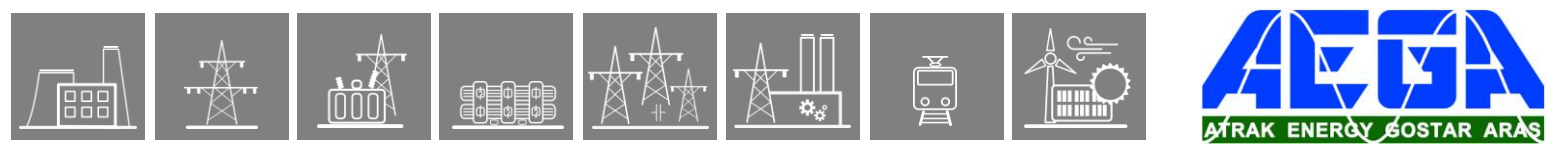

In this configuration also the „CB3pol” (circuit breaker control block) is applied. This block is needed if e.g. the front panel LCD of the device can display an active control scheme. For this purpose the signals „BIn_F...” in the Figure are the status signals of the circuit breaker poles, connected to the dedicated binary inputs of the device. The signals „Local”/”Remote” enable the local or remote control of the primary equipment. In the standard factory configurations these signals are programmed in the factory, but they can be modified also by the user.

If there is no synchro-check function activated in the device, connects the input „SynOK” of the “CB3Pol” to logic TRUE state.

According to *Figure 5-3*, the local command issued via LCD of the device or the remote command received from the remote SCADA system is processed by the „CB3pol” functionblock (Output „CmdOff”). This control is programmed in the factory to “BOut_xx” variables. The user can perform any modification in the graphic programming.

The close command is connected directly to a dedicated “BOut_xx” variable. (This directs usually the fourth contact of the TRIP hardware module.)

In *Figure 5-3* the close command is connected directly to a dedicated output. (This is usually the fourth contact of the TRIP hardware module.)

The programming of the interlocking function must be performed by the user.

An extension to the example in *Figure 5-2* is the application of the „REC79_HV” automatic reclosing function. The start signal „Trip_StartAR” can be programmed by the user. The automatic reclosing function is started only if the preceding trip command was performed by the circuit breaker, i.e. for example that the function is not disabled. The AND gate on this Figure performs this checking.

The „REC79_HV” automatic reclosing function needs the status signal indicating three-phase open state of the circuit breaker, connected to the „3PhTr” input of the „REC79_HV” functionblock. This signal is generated by the „TRC94_PhS” functionblock on the output „Tr3Ph”.

If the automatic reclosing is to be disabled after a fault caused by a manual close command, then the „CmdOn” output of the „CB3Pol” module must be connected to the „ManCl” input of the „REC79_HV” automatic reclosing function.

If there is no synchro-check function configured in the device, connect the „SynRel” input of the „REC79_HV” automatic reclosing function to logic TRUE state.

The evaluation of the status signals indicating the open state of the circuit breaker poles in OR gate is needed for the operation of the automatic reclosing function. According to the scheme of *Figure 5-3* the open state is indicated by at least one pole open state of the circuit breaker. (For simplicity, this Figure shows a realization without checking the FALSE signal of the closed states.)

Figure 5-3 supposes that the CB ready signal is not connected to the device; accordingly the steady TRUE state signal is connected to the „CBRdy” input of the „REC79_HV” automatic reclosing function. If the real signal is available, the signal must be connected similarly.

The close command of the „REC79_HV” automatic reclosing function is connected via OR gate to the dedicated close contact.

1.3.11.4.4. Closing the circuit breaker with synchro-check

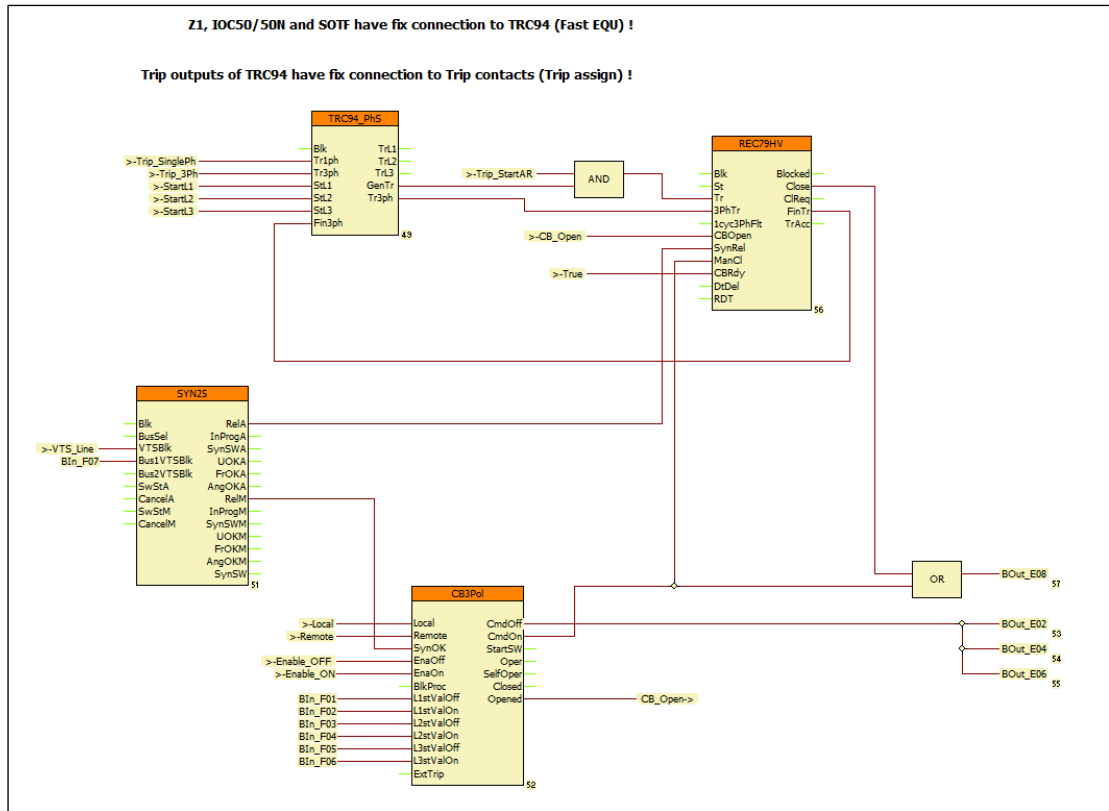

Figure 5-4 Example: closing the circuit breaker with synchro-check

Figure 5-4 shows an example for the application of “SYN25” cynchro-check functionblock. In this Figure it is supposed that the fast protection functions operate according to the factory configuration and they control the TRIP contacts applying two steps of the preparation and command generation phases. This part of the program is not visible in “Master” level. (The description of the fast operating protection functions are listed in the configuration description of the devices.)

The outputs of the TRC94_PhS trip logic block are assigned to the output channels of the TRIP hardware module. This assignment, which can be modified also by the user, is made not here but in the “TRIP assignment” menu of the EuroCAP configuration software. Consequently the Figure is complete; related to the outputs, the user needs additional graphic programming only if e.g. the operation is to be visualized also by signal relays.

If the configuration includes protection functions blocks the trip command of which does not need fast contact operation then these commands must be additionally assigned to the TRIP relay outputs. To do this, the user collects these commands (with OR connection) and assigns them to the dedicated inputs of the TRC94_PhS functionblock.

This Figure shows the collected signals (E.g. “Trip_SinglePh”, “Trip_3Ph”, etc.) only. As an example the „Trip_3ph” signal collects the commands of all (not fast operating) protection functions which can generate three-phase trip command. The detailed description of the inputs and operation of the “TRC94_PhS” trip logic functionblock can be found in another document.



In this configuration also the „CB3pol” (circuit breaker control block) is applied. This block is needed if e.g. the front panel LCD of the device can display an active control scheme. For this purpose the signals „Bln_F...” in the Figure are the status signals of the circuit breaker poles, connected to the dedicated binary inputs of the device. The signals „Local”/”Remote” enable the local or remote control of the primary equipment. In the standard factory configurations these signals are programmed in the factory, but they can be modified also by the user.

According to *Figure 5-4*, the local command issued via LCD of the device or the remote command received from the remote SCADA system is processed by the „CB3pol” functionblock (Output „CmdOff”). This control is programmed in the factory to “BOut_xx” variables. The user can perform any modification in the graphic programming.

The close command is connected directly to a dedicated “BOut_xx” variable. (This directs usually the fourth contact of the TRIP hardware module.)

In *Figure 5-4* the close command is connected directly to a dedicated output. (This is usually the fourth contact of the TRIP hardware module.)

The programming of the interlocking function must be performed by the user.

Figure 5-4 includes the application of the „REC79_HV” automatic reclosing function. The start signal „Trip_StartAR” can be programmed by the user. The automatic reclosing function is started only if the preceding trip command was performed by the circuit breaker, i.e. for example that the function is not disabled. The AND gate on this Figure performs this checking.

The „REC79_HV” automatic reclosing function needs the status signal indicating three-phase open state of the circuit breaker, connected to the „3PhTr” input of the „REC79_HV” functionblock. This signal is generated by the „TRC94_PhS” functionblock on the output „Tr3Ph”.

If the automatic reclosing is to be disabled after a fault caused by a manual close command, then the „CmdOn” output of the „CB3Pol” module must be connected to the „ManCl” input of the „REC79_HV” automatic reclosing function.

The evaluation of the status signals indicating the open state of the circuit breaker poles in OR gate is needed for the operation of the automatic reclosing function. According to the scheme of *Figure 5-4* the open state is indicated by at least one pole open state of the circuit breaker. (For simplicity, this Figure shows a realization without checking the FALSE signal of the closed states.)

Figure 5-4 supposes that the CB ready signal is not connected to the device; accordingly the steady TRUE state signal is connected to the „CBRdy” input of the „REC79_HV” automatic reclosing function. If the real signal is available, the signal must be connected similarly.

The close command of the „REC79_HV” automatic reclosing function is connected via OR gate to the dedicated close contact.

An extension to the example in *Figure 5-3* is the close command to the circuit breaker is generated by synchro-check. The enabling signal for the close command is generated by the „SYN25” software module. This module is described in details in a separate document. The needed input signals indicating the state of the voltage transformers („VTSBik” and „Bus1VTSBik”), must be programmed graphically.

The output signal „RelA” of the „SYN25” software module enables the closing operation of the „REC79_HV” automatic reclosing function via its „SynRel” input.

For manual close commands the output signal „ReIM” of the „SYN25” software module enables the closing operation of the „CB3pol” via its „SynOK” input.

1.3.11.4.5. Closing the circuit breaker with synchro-check and synchro-switch

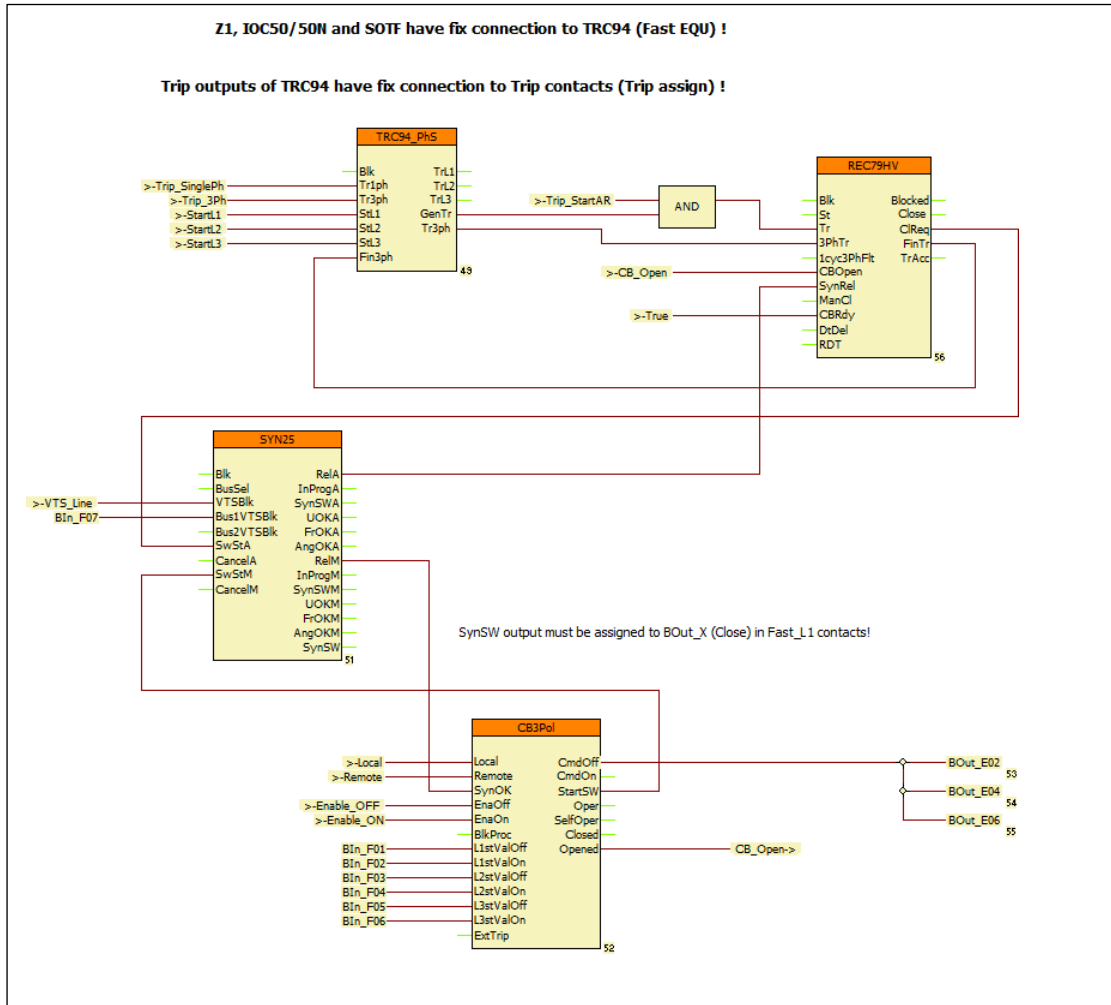
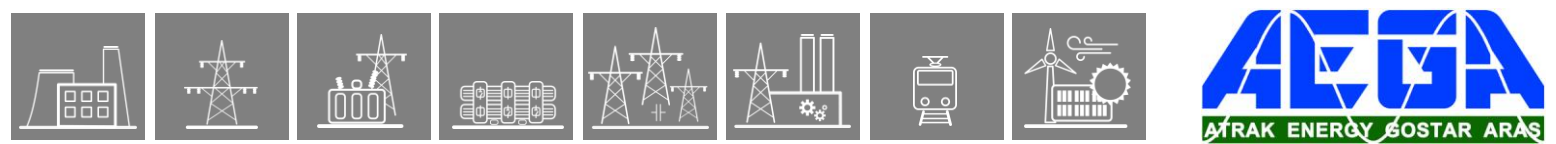

Figure 5-5 Example: closing the circuit breaker with synchro-check and synchro-switch

Figure 5-5 shows an example for the application of “SYN25” synchro-check function block with synchro switch extension. In this Figure it is supposed that the fast protection functions operate according to the factory configuration and they control the TRIP contacts applying two steps of the preparation and command generation phases. This part of the program is not visible in “Master” level. (The description of the fast operating protection functions are listed in the configuration description of the devices.)

The outputs of the TRC94_PhS trip logic block are assigned to the output channels of the TRIP hardware module. This assignment, which can be modified also by the user, is made not here but in the “TRIP assignment” menu of the EuroCAP configuration software. Consequently the Figure is complete; related to the outputs, the user needs additional graphic programming only if e.g. the operation is to be visualized also by signal relays.

If the configuration includes protection functions blocks the trip command of which does not need fast contact operation then these commands must be additionally assigned to the TRIP relay outputs. To do this, the user collects these commands



(with OR connection) and assigns them to the dedicated inputs of the TRC94_PhS functionblock.

This Figure shows the collected signals (E.g. “Trip_SinglePh”, “Trip_3Ph”, etc.) only. As an example the „Trip_3ph” signal collects the commands of all (not fast operating) protection functions which can generate three-phase trip command. The detailed description of the inputs and operation of the “TRC94_PhS” trip logic functionblock can be found in another document.

In this configuration also the „CB3pol” (circuit breaker control block) is applied. This block is needed if e.g. the front panel LCD of the device can display an active control scheme. For this purpose the signals „BIn_F...” in the Figure are the status signals of the circuit breaker poles, connected to the dedicated binary inputs of the device. The signals „Local”/”Remote” enable the local or remote control of the primary equipment. In the standard factory configurations these signals are programmed in the factory, but they can be modified also by the user.

According to *Figure 5-5*, the local command issued via LCD of the device or the remote command received from the remote SCADA system is processed by the „CB3pol” functionblock (Output „CmdOff”). This control is programmed in the factory to “BOut_xx” variables. The user can perform any modification in the graphic programming.

The close command is connected directly to a dedicated “BOut_xx” variable. (This directs usually the fourth contact of the TRIP hardware module.)

In *Figure 5-5* the close command is connected directly to a dedicated output. (This is usually the fourth contact of the TRIP hardware module.)

The programming of the interlocking function must be performed by the user.

Figure 5-5 includes the application of the „REC79_HV” automatic reclosing function. The start signal „Trip_StartAR” can be programmed by the user. The automatic reclosing function is started only if the preceding trip command was performed by the circuit breaker, i.e. for example that the function is not disabled. The AND gate on this Figure performs this checking.

The „REC79_HV” automatic reclosing function needs the status signal indicating three-phase open state of the circuit breaker, connected to the „3PhTr” input of the „REC79_HV” functionblock. This signal is generated by the „TRC94_PhS” functionblock on the output „Tr3Ph”.

If the automatic reclosing is to be disabled after a fault caused by a manual close command, then the „CmdOn” output of the „CB3Pol” module must be connected to the „ManCl” input of the „REC79_HV” automatic reclosing function.

If there is no synchro-check function configured in the device, then connect the „SynRel” input of the „REC79_HV” automatic reclosing function to logic TRUE state.

The evaluation of the status signals indicating the open state of the circuit breaker poles in OR gate is needed for the operation of the automatic reclosing function. According to the scheme of *Figure 5-5* the open state is indicated by at least one pole open state of the circuit breaker. (For simplicity, this Figure shows a realization without checking the FALSE signal of the closed states.)

Figure 5-5 supposes that the CB ready signal is not connected to the device; accordingly the steady TRUE state signal is connected to the „CBRdy” input of the „REC79_HV” automatic reclosing function. If the real signal is available, the signal must be connected similarly.

The close command of the „REC79_HV” automatic reclosing function is connected via OR gate to the dedicated close contact.

In this application the close command to the circuit breaker is generated by synchro-check. The enabling signal for the close command is generated by the „SYN25” software module. This module is described in details in a separate document. The

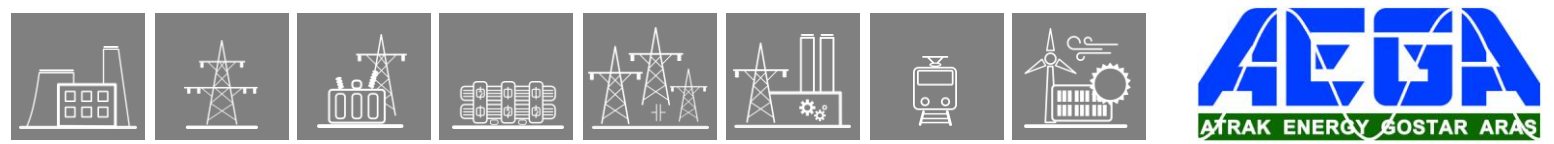

needed input signals indicating the state of the voltage transformers („VTSBIK” and „Bus1VTSBIK”), must be programmed graphically.

The output signal „RelA” of the „SYN25” software module enables the closing operation of the „REC79_HV” automatic reclosing function via its „SynRel” input.

For manual close commands the output signal „RelM” of the „SYN25” software module enables the closing operation of the „CB3pol” via its „SynOK” input.

An extension to the example in *Figure 5-4* is the following: If there is no continuous synchron state because the frequency at one side of the circuit breaker is different to that of the other side, then the voltage vector of one side rotates continuously as compared to the other one. In this case a synchronous switching is attempted to restore the normal operation of the network.

The manual synchron switching mode is started by the signal on the „StSwM” input of the SYN25 functionblock. To do this the the „StartSW” output of the „CB3Pol” functionblock must be connected here.

For automatic synchron switching mode the „CIReq” output of the „Rec79HV” module must be connected to the „SwStA” input of the „SYN25” software module.

IMPORTANT NOTE: the close command is generated for both manual and automatic

switching at the output „SynSW” of the „SYN25” software module. It is advised not to connect this output using the „slow” graphic programming, but the contact assigned to the close command („BOutClose”) must be handled as fast operating „L1 contact”. The „SynSW” signal must be programmed to this contact. This assignment is performed using the EuroCap configuration tool in the menu „Hardware configuration/Binary outputs/Relay contacts/Fast_L1 contacts”.

1.3.12. RTD input module

The RTD+1100 module is used to measure the temperature through the variation of resistance of temperature detectors. RTD+0200 and RTD+1200 are special modules for Petersen coil controllers (DRL) measuring the resistance of the potentiometer.

Connector types:

- The default and optionally available connector types are indicated for each module in the table below. See Chapter 20.2 for details about each type.

MODULE TYPE	RTD+/0200*	RTD+/1100	RTD+/1200*
CHANNEL NUMBER	1	4	1
MEASUREMENT METHOD	3 wire configuration	2, 3 or 4 wire configuration	3 wire configuration
ACCURACY	± 0.5 % ± 1 digit	± 0.5 % ± 1 digit	± 0.5 % ± 1 digit
SENSOR TYPE	Service-Ohm	Pt100/Ni100 Ni120/Ni120US Pt250/Ni250 Pt1000/Ni1000 Cu10 Service-Ohm (60 Ω ... 1.6 kΩ)	Service-Ohm
MEASUREMENT RANGES	2 Ω ... 200 Ω	- 50 °C – +150 °C	10 Ω ... 1000 Ω
CONNECTOR TYPE	<u>Default:</u> BLA <u>Options:</u> -	<u>Default:</u> BLA <u>Options:</u> T	<u>Default:</u> BLA <u>Options:</u> -
RECOMMENDED APPLICATION	Arc suppression coil controller	General resistance-based temperature measurement	Arc suppression coil controller

*Special module

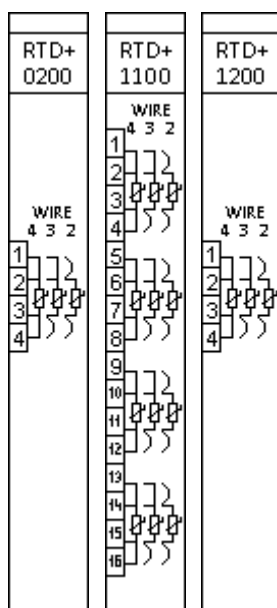

Figure 10-1 RTD input modules

1.3.12.1. RTD module wiring

If 2-wire wiring is used you have to make sure that the value of RA and RD resistors are set correctly in the “parameters” menu of the web server.

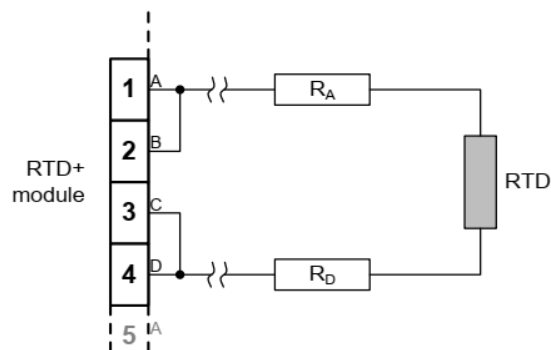

Figure 10-2 2-wire RTD wiring

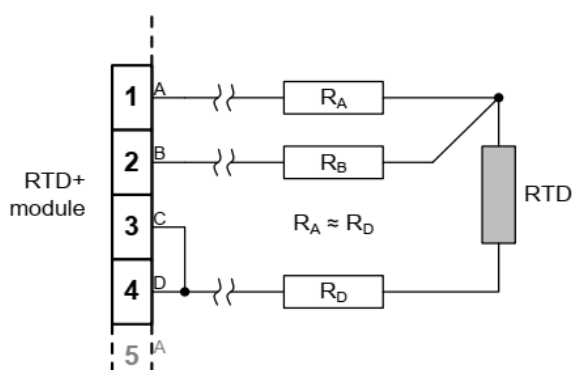

Figure 10-3 3-wire RTD wiring

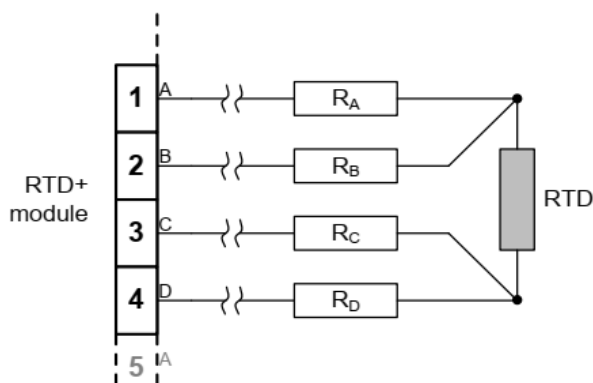

Figure 10-4 4-wire RTD wiring

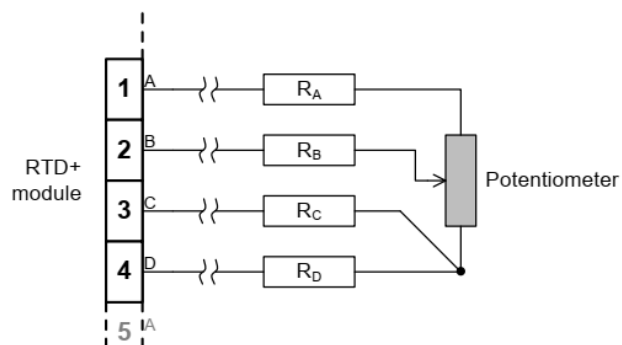

Figure 10-5 4-wire RTD wiring of potentiometer

1.3.13. Analog input module (AI)

The analog input module accepts transducers' current outputs. The AIC module can measure unipolar and bipolar current values in wide ranges.

Connector types:

- The default and optionally available connector types are indicated for each module in the table below. See Chapter 20.2 for details about each type.

MODULE TYPE	AIC+/0200*	AIC+/0201*	AIC+/0202
CHANNEL NUMBER	4	4	4
MEASUREMENT METHOD	2 wire inputs	2 wire inputs with optional 12 V excitation	2 wire inputs
RELATIVE ACCURACY	$\pm 0.5 \% \pm 1$ digit	$\pm 0.5 \% \pm 1$ digit	$\pm 0.5 \% \pm 1$ digit
MEASUREMENT RANGES	± 20 mA (typical 0-20, 4-20 mA) $R_{LOAD} = 56 \Omega$	± 20 mA (typical 0-20, 4-20 mA) $R_{LOAD} = 56 \Omega$	± 20 mA (typical 0-20, 4-20 mA) $R_{LOAD} = 56 \Omega$
CONNECTOR TYPE	Default: BLA Options: -	Default: BLA Options: -	Default: BLA Options: F, T

*Obsolete module. These modules are not recommended for new designs!

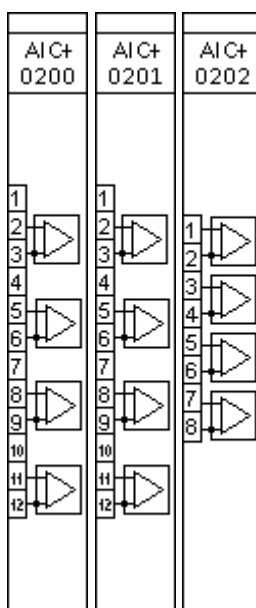
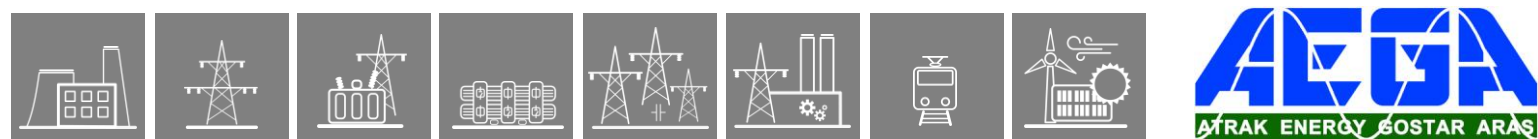

Figure 11-1 Analog input modules



1.3.13.1. AI module wiring

The following wiring method can be applied.

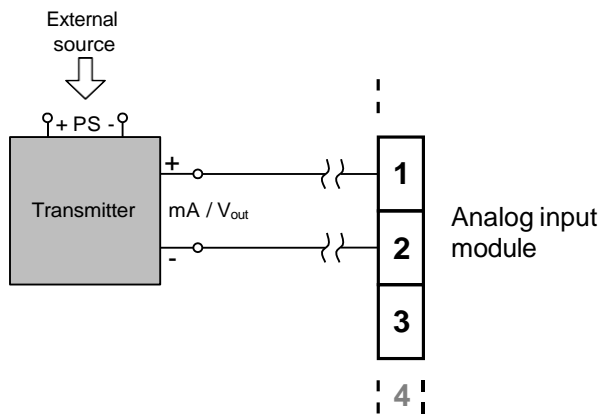

Figure 11-2 AI wiring

1.3.14. Analog output module (ATO)

The analog output module transmits current or voltage signals. The ATO module can be used in wide ranges in unipolar and bipolar mode.

Connector types:

- The default and optionally available connector types are indicated for each module in the table below. See Chapter 20.2 for details about each type.

MODULE TYPE	ATO+/0002	ATO+/0004
CHANNEL NUMBER	2	4
OUTPUT MODE	2 wire output	2 wire output
MAXIMUM LOAD ($R_{\text{CABLE}} + R_{\text{RECEIVER}}$)	500 Ω	500 Ω
OUTPUT RANGES	± 20 mA 0 - 20 mA 4 - 20 mA	± 20 mA 0 - 20 mA 4 - 20 mA
CONNECTOR TYPE	Default: BLA Options: T	Default: BLA Options: -

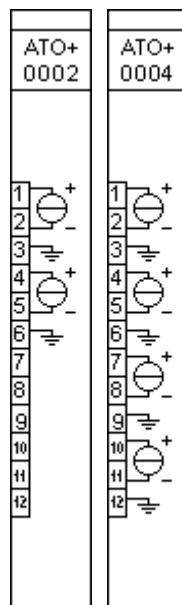
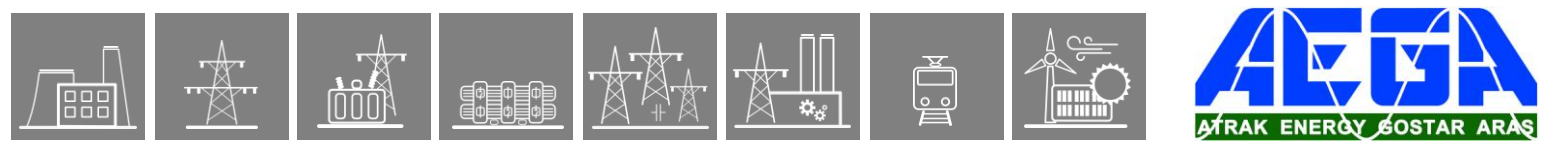

Figure 12-1 Analog output modules



1.3.14.1. ATO module wiring

The analog output module should be connected according to the following wiring diagram.

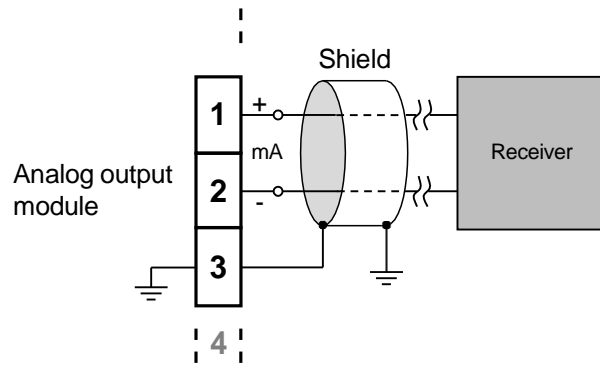

Figure 12-2 Analog output module wiring diagram



1.3.15. Sensor input module

The sensor modules receive low-level signals of current and voltage sensors (low-power instrument transformers).

Connector types:

- The default and optionally available connector types are indicated for each module in the table below. See Chapter 20.2 for details about each type.

MODULE TYPE	CVS+/0001		CVSR+/0001		VS+/0031***
CHANNEL NUMBER	4 U	4 I	4 U	4 I	4 U
NOMINAL VALUES	3.25 V	0.225 V*	1.27 V	0.150 V**	3.25 V
CONTINUOUS VOLTAGE WITHSTAND	35 V DC		35 V DC		35 V DC
SHORT TIME OVERLOAD (1 s)	40 V AC / 56 V DC		40 V AC / 56 V DC		40 V AC / 56 V DC
MAX. MEASURED VALUE ($\pm 10\%$)	1.8 U _N	50 I _N	2.1 U _N	50 I _N	1.6 U _N
ACCURACY	$\leq 0.5\%$ (0.1 U _N – 1.2 U _N)		$\leq 0.5\%$ (0.1 U _N – 1.2 U _N)		$\leq 0.5\%$ (0.1 U _N – 1.2 U _N)
FREQUENCY RANGE	DC – 1 kHz		DC – 1 kHz		DC – 1 kHz
INPUT RESISTANCE	200 k Ω $\pm 1\%$	21 k Ω $\pm 1\%$	10 M Ω $\pm 1\%$	1.1 M Ω $\pm 1\%$	200 k Ω $\pm 1\%$
INPUT CAPACITANCE	300 pF (1 kHz)	300 pF (1 kHz)	300 pF (1 kHz)	300 pF (1 kHz)	300 pF (1 kHz)
CONNECTOR TYPE	RJ45 – 8 pole, shielded connector, isolated shielding		RJ45 – 8 pole, shielded connector, grounded shielding		M8 3-pin connector <u>Receptacle:</u> Hirschmann ELST 3308 RV FM 8 05 <u>Plug:</u> Binder 768 99-3360-00-03

*Voltage proportional to current

**Voltage proportional to current change (Rogowski coil)

*****Obsolete module. These modules are not recommended for new designs!**

For more information about more available nominal values please contact our Application Team. (application@protecta.hu)

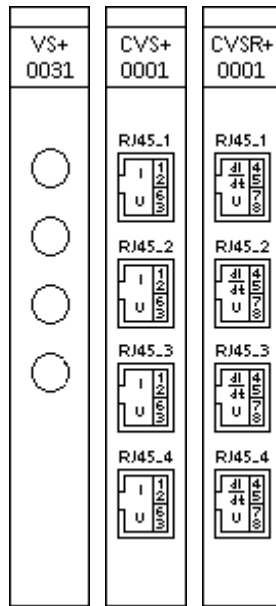

Figure 13-1 Voltage sensor modules

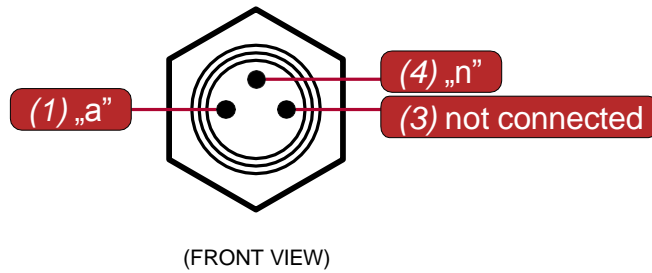
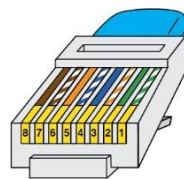

Figure 13-2 M8 connector pinout



- 1.: S1
- 2.: S2
- 3.: "a"
- 6.: "n"

Figure 13-3 CVS module connector pinout



- 4.: S1
- 5.: S2
- 8.: "n"
- 7.: "a"

Figure 13-4 CVSR module connector pinout

1.3.16. INJ module

Complex module for controlling the Petersen coil, which contains an injector function for the measurements, an enabling and a blocking input, and a fault relay indicating if there is any fault in the injection circuit.

Connector types:

- The default and optionally available connector types are indicated for each module in the table below. See Chapter 20.2 for details about each type.

MODULE TYPE	INJ+/0005	INJ+/0015*
INJECTED CURRENT	2 A	4 A
ENABLING INPUT CLAMP VOLTAGE	85 V AC	Not available function
BLOCKING INPUT CLAMP VOLTAGE	200 V AC	200 V AC
ADDITIONAL RESISTANCE FOR VOLTAGE INPUT	Not available function	265 kΩ ± 1%
CONNECTOR TYPE	Default: STVS6, BLA10 Options: -	
RECOMMENDED APPLICATION	Arc suppression coil controller	Network compensation level measurement on resonant grounded networks

*Special module

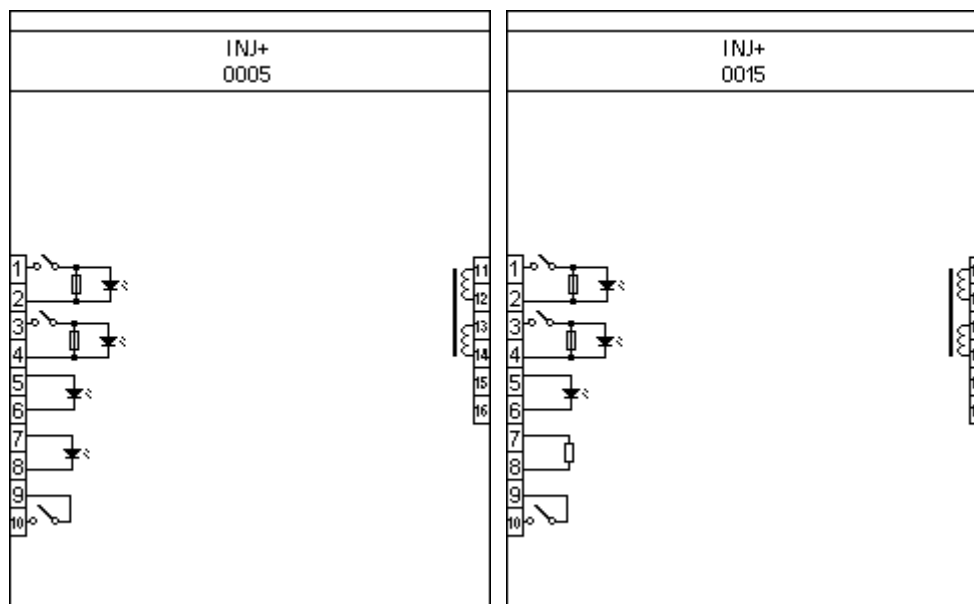

Figure 14-1 INJ modules

1.3.17. Generator protection modules

Special generator protection modules whose system measures and produces the necessary analog signals.

Connector types:

- The default and optionally available connector types are indicated for each module in the tables below. See Chapter 20.2 for details about each type.

MODULE TYPE	RAI+/01	RAI+/11	RINJ+/21
NOMINAL VOLTAGE	-	-	110 V / 220 V
INPUT VOLTAGE RANGE	-	-	88 - 264 V DC 80 - 250 V AC
OUTPUT VOLTAGE	-	-	100V DC \pm 2 %
MEASUREMENT RANGE	\pm 20 mA	\pm 20 mA	-
THERMAL WITHSTAND CONTINUOUS: 30 SEC:	15 mA 20 mA	10 mA 20 mA	20 mA
CONNECTOR TYPE	<u>Default:</u> STVS8 <u>Options:</u> -	<u>Default:</u> STVS8 <u>Options:</u> T*	<u>Default:</u> STVS8 <u>Options:</u> T*
RECOMMENDED APPLICATION	Rotor earth-fault protection of middle-grounded rotors	Rotor earth-fault protection of ungrounded (isolated) rotors	Rotor earth-fault protection of ungrounded (isolated) rotors

*By choosing this option, the connector remains the same, only the handle is changed

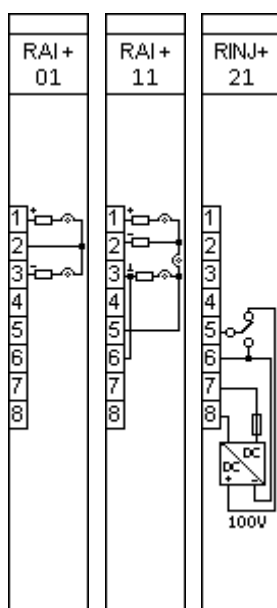

Figure 15-1 Generator protection modules

1.3.17.1. Auxiliary boxes for rotor earth fault protection

These DIN-rail mounted external boxes serve as couplings between the rotor (exciter circuit) of the generator and the corresponding RAI module of the protection device.

Note: the data about the resistances and capacitors provided here does not tell the actual time constants of the measured values, as those can be determined on-site only, when the rotor earth fault protection is being tested on the actual generator itself.

MODULE TYPE	RAI+01 BOX	RAI+11 BOX BASE	RAI+11 BOX EXTENSION*
MAXIMUM INPUT VOLTAGE	200 V, 300 V, 400 V, 500 V**	600 V	1200 V
SERIES RESISTANCE ON SIDES	10 k Ω , 15 k Ω , 20 k Ω , 25 k Ω **	35 k Ω	30 k Ω
FILTER CAPACITORS	4x10 μ F	2x1 μ F	-
CONNECTOR TYPE	Default: STVS6 Options: -	Default: STVS6 Options: -	Default: STVS6 Options: -
RECOMMENDED APPLICATION	Middle-grounded rotors	Ungrounded (isolated) rotors	Ungrounded (isolated) rotors

*This extension module can only be used together with RAI+11 BOX BASE module

**According to the chosen wiring

1.3.17.1.1. Use of auxiliary boxes

- **Ungrounded (isolated) rotors:**

If the excitation voltage is lower than 600 V, then it is enough to use the RAI+11 BOX BASE auxiliary box. If the excitation voltage is higher than 600 V, the RAI+11 BOX EXTENSION auxiliary box shall be used *additionally*, so the protection can connect to up to 1200 V excitation voltage.

- **Middle-grounded rotors**

Front drawings near the connectors on the box itself indicate the available maximum voltages. The choice from these shall be made according to the excitation voltage. Wiring shall be done according to the chosen voltage.

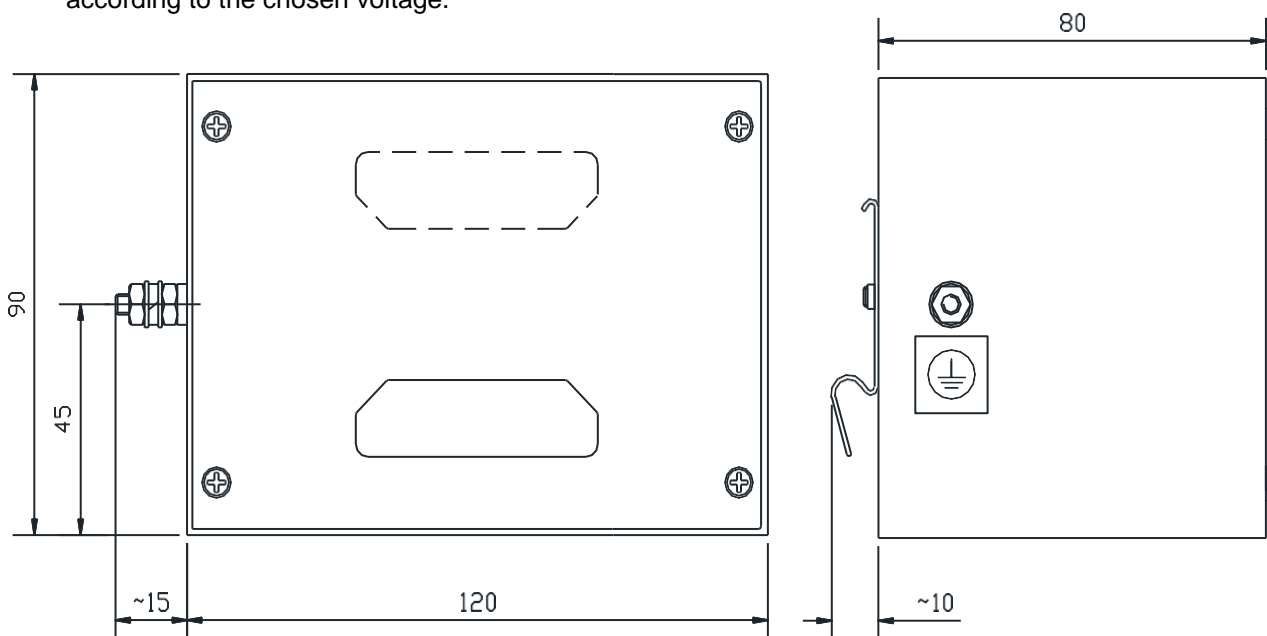

Figure 15-2 Size of the auxiliary boxes

1.3.17.2. Wiring of the rotor earth fault protection modules

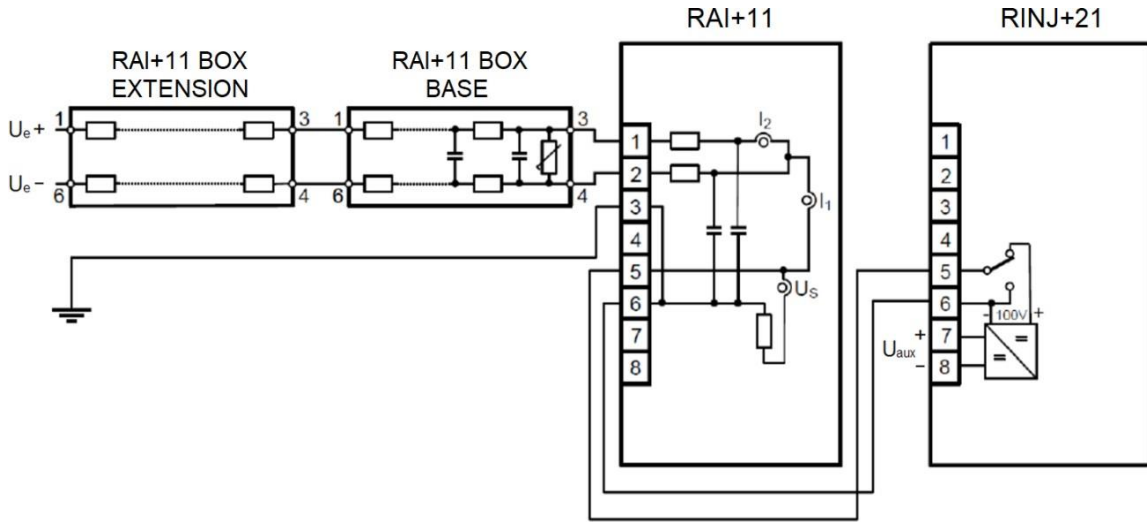

Figure 15-3 Wiring for ungrounded (isolated) rotors

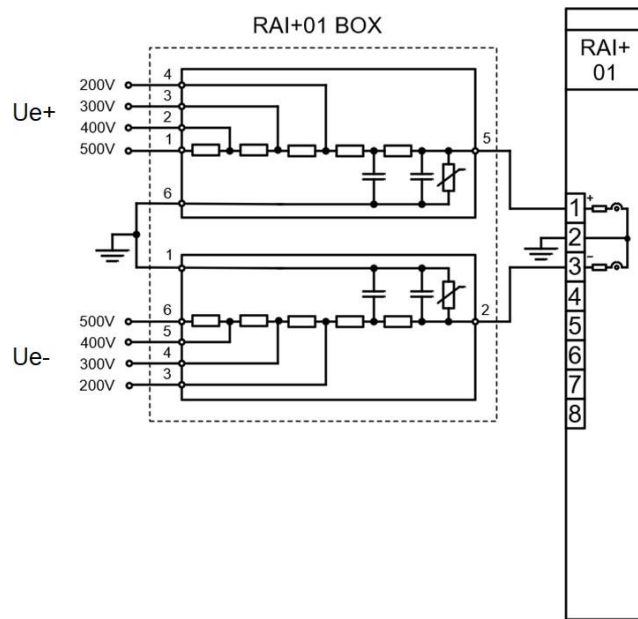
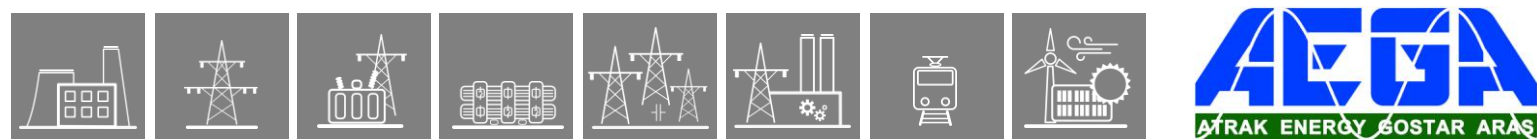

Figure 15-4 Wiring for middle-grounded rotors



1.3.18. Power supply module

The power supply module converts primary AC and/or DC voltage to required system voltages. In most applications, one power supply module is sufficient to provide the required power to the system. Redundant power supply modules extend system availability in case of the outage of any power source.

IMPORTANT

Depending on the hardware configuration, the power consumption of the devices can be different. We reserve the right to make the decision about which PS+ module must be used.

For most applications where the power consumption does not reach 20 W, a 4 HP wide PS+ module shall be installed.

Connector types:

- The default and optionally available connector types are indicated for each module in the tables below. See Chapter 20.2 for details about each type.

MODULE TYPE	PS+/4201 (4 HP wide)	PS+/2101 (4 HP wide)
RATED VOLTAGE	24 V DC / 48 V DC / 60 V DC	110 V DC / 220 V DC
INPUT VOLTAGE OPERATIVE RANGE	19.2 - 72 V DC	88 - 264 V DC 80 - 250 V AC
NOMINAL POWER	20 W	20 W
VOLTAGE DIP WITHSTAND AT 80% UN → 0% INPUT VOLTAGE CHANGE (IEC 60255-26)	50 ms	100 ms
INTERNAL FUSE	3.15A/250V	3.15A/250V
CONNECTOR TYPE	<u>Default:</u> BLA <u>Options:</u> T	<u>Default:</u> BLA <u>Options:</u> F, T

IMPORTANT

Devices with 20W or higher power consumption shall be equipped with an 8 HP wide PS module.

MODULE TYPE	PS+/1301	PS+/1303**	PS+/2301	PS+/2303**	PS+/1030*
RATED VOLTAGE	110 V DC	110 V DC	220 V DC	220 V DC	110 V DC / 220 V DC
INPUT VOLTAGE OPERATIVE RANGE	88 - 132 V DC 85 - 130 V AC	88 - 150 V DC 85 - 130 V AC	176 - 264 V DC 160 - 250 V AC	176 - 264 V DC 160 - 250 V AC	88 - 264 V DC 85 - 250 V AC
MAX. CONTINUOUS POWER OUTPUT	30 W	30 W	30 W	30 W	25 W
VOLTAGE DIP WITHSTAND AT 80% UN → 0% INPUT VOLTAGE CHANGE (IEC 60255-26)	50 ms 100 ms at 100%Un → 0%	50 ms 100 ms at 100%Un → 0%	50 ms 100 ms at 100%Un → 0%	50 ms 100 ms at 100%Un → 0%	20 ms 100 ms at 100%Un → 0%
INTERNAL FUSE	2.5A/250V	2.5A/250V	2.5A/250V	2.5A/250V	2.5A/250V
CONNECTOR TYPE	<u>Default:</u> BLA <u>Options:</u> -	<u>Default:</u> BLA <u>Options:</u> -	<u>Default:</u> BLA <u>Options:</u> -	<u>Default:</u> BLA <u>Options:</u> -	<u>Default:</u> BLA <u>Options:</u> F, T

*Special module, available only in custom configurations.

**Can be connected in parallel.

MODULE TYPE	PS+/1060*	PS+/1601	PS+/1602*	PS+/2601	PS+/4301***
RATED VOLTAGE	110 V DC / 220 V DC	110 V DC	110 V DC	220 V DC	48 V DC
INPUT VOLTAGE OPERATIVE RANGE	88 - 264 V DC	88 - 132 V DC 95 - 130 V AC	88 - 132 V DC 95 - 130 V AC	176 - 264 V DC 160 - 250 V AC	38.4 - 57.6 V DC
MAX. CONTINUOUS POWER OUTPUT	60 W	60 W	60 W	60 W	25 W
VOLTAGE DIP WITHSTAND AT 80% UN → 0% INPUT VOLTAGE CHANGE (IEC 60255-26)	20 ms 100 ms at 100%Un → 0%	50 ms 100 ms at 100%Un → 0%	50 ms 100 ms at 100%Un → 0%	50 ms 100 ms at 100%Un → 0%	20 ms 30 ms at 100%Un → 0%
INTERNAL FUSE	3.15A/250V	2.5A/250V	2.5A/250V	2.5A/250V	3.15A/250V
CONNECTOR TYPE	<u>Default:</u> BLA <u>Options:</u> F, T	<u>Default:</u> BLA <u>Options:</u> -	<u>Default:</u> BLA <u>Options:</u> F	<u>Default:</u> BLA <u>Options:</u> T	<u>Default:</u> BLA <u>Options:</u> -

*Special module, available only in custom configurations. PS+1602 supports auxiliary voltage measurement. The module is calibrated to DC voltage measurement.

***Obsolete module. These modules are not recommended for new designs!

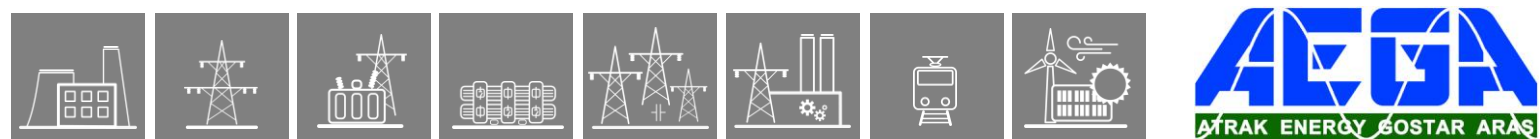

MODULE TYPE	PS+/2161*	PS+/2164**	PS+/4261*	PS+/4264**
RATED VOLTAGE	110 V DC / 220 V DC	110 V DC / 220 V DC	24 V DC / 48 V DC / 60 V DC	24 V DC / 48 V DC / 60 V DC
INPUT VOLTAGE OPERATIVE RANGE	88 - 264 V DC	88 - 264 V DC	19.2 - 72 V DC	19.2 - 72 V DC
MAX. CONTINUOUS POWER OUTPUT	60 W	60 W	60 W	60 W
VOLTAGE DIP WITHSTAND AT 80% UN → 0% INPUT VOLTAGE CHANGE (IEC 60255-26)	40 ms	40 ms	40 ms	40 ms
INTERNAL FUSE	3.15A/250V	3.15A/250V	8A/250V	8A/250V
CONNECTOR TYPE	<u>Default:</u> BLT <u>Options:</u> -	<u>Default:</u> BLT <u>Options:</u> -	<u>Default:</u> BLT <u>Options:</u> -	<u>Default:</u> BLT <u>Options:</u> -

***Can be connected in parallel.**Can be connected in parallel and supports auxiliary voltage measurement.**

MODULE TYPE	PS+/4401**	PS3F+/1001*
RATED VOLTAGE	48 V DC / 60 V DC	3x100 V AC (line voltage)
INPUT VOLTAGE OPERATIVE RANGE	38.4 - 72 V DC	80 - 120 V AC
MAX. CONTINUOUS POWER OUTPUT	30 W	20 W
VOLTAGE DIP WITHSTAND AT 80% UN → 0% INPUT VOLTAGE CHANGE (IEC 60255-26)	20 ms 30 ms at 100%Un → 0%	50 ms 100 ms at 100%Un → 0%
INTERNAL FUSE	3.15A/250V	2.5A/250V
CONNECTOR TYPE	<u>Default:</u> BLA <u>Options:</u> F, T	<u>Default:</u> BLA <u>Options:</u> -

***Special module.** At least 2 healthy phase voltages are needed for the operation of the PS3F+1001 module. LEDs on the front of the module indicate the presence of healthy phase voltages. For the correct internal signals connect the common point of the supplying 3 phase voltage to the 4th connector ("N").

****Can be connected in parallel.**

Main features:

- Fault relay contacts (NC and NO): device fault contact and also assignable to user functions. All the three relay contact points are accessible to users.
- Redundant applications (nominal power and reliability can be increased by using parallel power supplies)
- On-board self-supervisory circuits: temperature and voltage monitors
- Short-circuit-protected outputs
- Efficiency: > 70 %, power consumption = nominal power / efficiency
- Passive heatsink

- Early power failure indication signals to the CPU for the possibility of power outage, thus the CPU has enough time to save the necessary data to non-volatile memory
- Inrush current (until 0.1 s): < 10 A for all types excluding PS+4401 which has < 21 A inrush current.
- Common features for internal fuses:
 - 5 mm x 20 mm (0.20" x 0.79")
 - TT characteristics (very inverse time-lag)
 - 35 A @ 250 V AC rated breaking capacity
- Recommended external protection: miniature circuit breaker, 6 A (C char.)

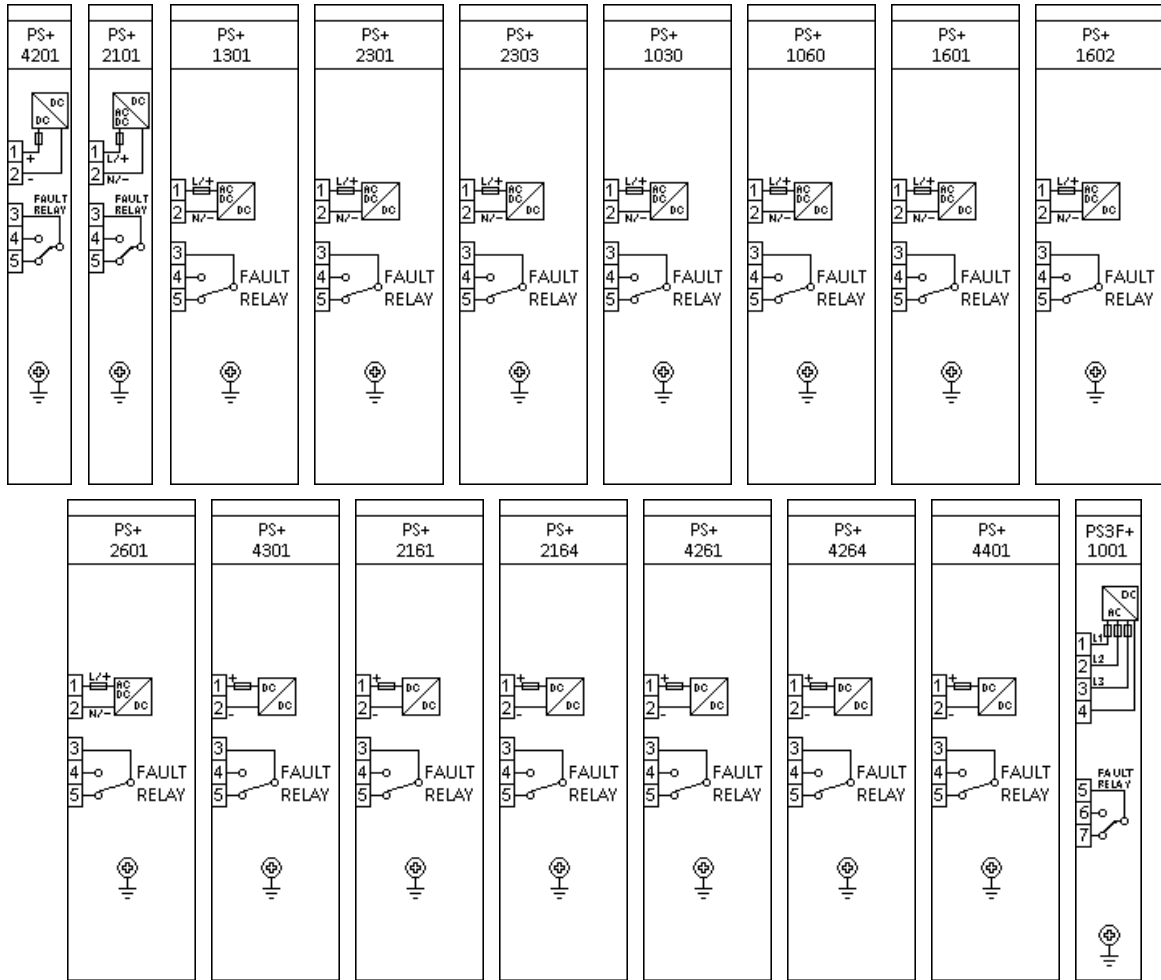

Figure 16-1 Power supply modules

1.3.19. Sampling synchronization module

The IED sampling system is synchronized via this module to an external source (IRIG-B) in PMU (Phasor Measurement Unit) applications. The PLL of the module handles the setting of the phase and frequency if valid IRIG-B signal is received. Note that the sampling signal is generated even if the IRIG-B signal is not present, however in that case, it runs independently.

MODULE TYPE	TSYNC+/0071
IRIG-B TYPE	B000 (unmodulated)
INPUT TYPE	BNC (coaxial)
SIGNAL THRESHOLD	5 VDC CMOS max. 5.5 VDC
MAX. CABLE LENGTH	50 m
CLAMP VOLTAGES	falling 1.7 VDC rising 3.1 VDC
SAMPLING ACCURACY*	< 100 ns
IRIG SYNCH. TIME	max. 1 minute
HOLDOVER TIME**	30 s
SAMPLING FREQUENCY	2 kHz @ 50 Hz 2.4 kHz @ 60 Hz
SAMPLING ACCURACY IN INDEPENDENT MODE***	< 1 ppm

*max. time difference between synchronized systems connecting to different GNSS (e.g. GPS)

**the sampling accuracy stays below the given value during this time if the IRIG-B signal is lost

***the accuracy of the 2/2.4 kHz sampling signal if an IRIG-B signal is not present

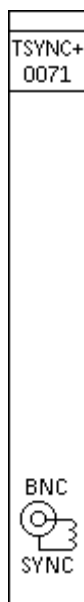

Figure 17-1 Sampling synchronization module

1.3.20. Mixed function modules

1.3.20.1. PSTP+ module

IMPORTANT

PSTP+ modules can be used only if the power consumption of the device does not reach 20 W and maximum 2 TRIP contacts are needed. If the application does not meet any of these two requirements, it is not allowed to use these cards. In this case separate PS+ (Chapter 16) and TRIP+ (Chapter 9) modules must be used.

Connector types:

- The default and optionally available connector types are indicated for each module in the tables below. See Chapter 20.2 for details about each type.

Note for the following tables:

- Thermal withstand voltage:** continuous with 60 % of the input channels are energized.

MODULE TYPE	PSTP+/2101	PSTP+/2102*	PSTP+/2131**
	POWER SUPPLY CHARACTERISTICS		
RATED VOLTAGE	110 V / 220 V	110 V / 220 V	110 V / 220 V
INPUT VOLTAGE OPERATIVE RANGE	88 - 264 V DC 80 - 250 V AC	88 - 264 V DC 80 - 250 V AC	88 - 264 V DC 80 - 250 V AC
MAXIMUM CONTINUOUS POWER OUTPUT	20 W	20 W	20 W
VOLTAGE DIP DURATION AT 0% RESIDUAL VOLTAGE (IEC 60255-26)	min. 100 ms in the specified input voltage range	min. 100 ms in the specified input voltage range	min. 100 ms in the specified input voltage range
INTERNAL FUSE	3.15A/250V	3.15A/250V	3.15A/250V
CONNECTOR TYPE	Default: BLA Options: F, T	Default: BLA Options: F, T	Default: BLA Options: T
	TRIPPING CHARACTERISTICS		
CHANNEL NUMBER	2	2	2
RATED VOLTAGE	110 V DC and 220 V DC or dry contacts	110 V DC and 220 V DC or dry contacts	110 V DC and 220 V DC or dry contacts
THERMAL WITHSTAND VOLTAGE	242 V DC	242 V DC	242 V DC
CONTINUOUS CARRY	8 A	8 A	8 A
MAKING CAPACITY	0.5 s, 30 A	0.5 s, 30 A	0.5 s, 30 A
BREAKING CAPACITY	L/R = 40 ms: 4 A DC	L/R = 40 ms: 4 A DC	L/R = 40 ms: 4 A DC
CONNECTOR TYPE	Default: BLA Options: F, T	Default: BLA Options: F, T	Default: BLA Options: T

*Special module that supports **auxiliary voltage measurement**. The module is calibrated to DC voltage measurement.

**Without trip circuit supervision

MODULE TYPE	PSTP+/4201	PSTP+/4202*
	POWER SUPPLY CHARACTERISTICS	
RATED VOLTAGE	24 V / 48 V / 60 V	24 V / 48 V / 60 V
INPUT VOLTAGE OPERATIVE RANGE	19.2 - 72 V DC	19.2 - 72 V DC
MAXIMUM CONTINUOUS POWER OUTPUT	20 W	20 W
VOLTAGE DIP DURATION AT 0% RESIDUAL VOLTAGE (IEC 60255-26)	50 ms at nominal input voltages min. 40 ms in the specified input voltage range	50 ms at nominal input voltages min. 40 ms in the specified input voltage range
INTERNAL FUSE	3.15A/250V	3.15A/250V
CONNECTOR TYPE	<u>Default:</u> BLA <u>Options:</u> T	<u>Default:</u> BLA <u>Options:</u> T
	TRIPPING CHARACTERISTICS	
CHANNEL NUMBER	2	2
RATED VOLTAGE	24 V DC and 48 V DC or dry contacts	24 V DC and 48 V DC or dry contacts
THERMAL WITHSTAND VOLTAGE	72 V DC	72 V DC
CONTINUOUS CARRY	8 A	8 A
MAKING CAPACITY	0.5 s, 30 A	0.5 s, 30 A
BREAKING CAPACITY	L/R = 40 ms: 4 A DC	L/R = 40 ms: 4 A DC
CONNECTOR TYPE	<u>Default:</u> BLA <u>Options:</u> T	<u>Default:</u> BLA <u>Options:</u> T

***Special module** that supports **auxiliary voltage measurement**. The module is calibrated to DC voltage measurement.

Main features:

- High-speed operation: with pre-trip 0.5 ms, without pre-trip typically 10 ms, maximally 22 ms.
- Trip circuit supervision for each trip contact
- 1 unit wide (4 HP) modules
- Inrush current (until 0.1 s): < 10 A
- Common features for internal fuses:
 - 5 mm x 20 mm (0.20" x 0.79")
 - TT characteristics (very inverse time-lag)
 - 35 A @ 250 V AC rated breaking capacity
- Recommended external protection: miniature circuit breaker, 6 A (C char.)

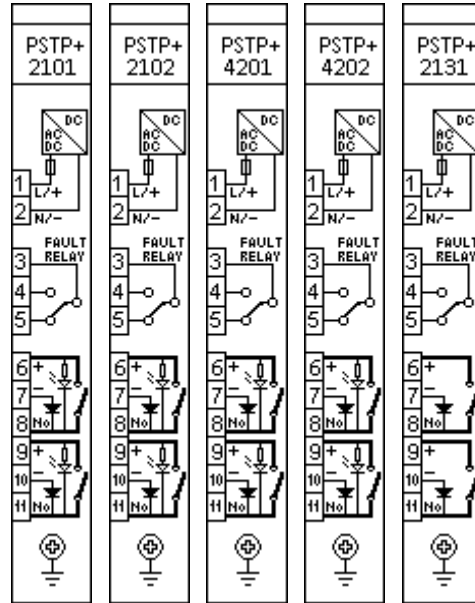

Figure 18-1 Power supply with 2 Ch. TRIP modules

1.3.20.1.1. Trip Circuit Supervision (TCS) in PSTP modules

Apart from the PSTP+/2131, all PSTP modules have TCS.

The technical data of the TCS in PSTP modules:

	MODULE TYPE	PSTP+/4201 PSTP+/4202	PSTP+/2101 PSTP+/2102
		INJECTED CURRENT AT "NO" CONTACT	1.5 mA
MAXIMUM RESISTANCE OF THE TRIP COIL	3-WIRE WIRING (1 mA CURRENT)	8 kΩ (max. 8 V)	13 kΩ (max. 13 V)
	3-WIRE WIRING IN PARALLEL	4 kΩ (max. 8 V)	6.5 kΩ (max. 13 V)
	2-WIRE METHOD (1 mA MIN. CURRENT)	24 kΩ @ 24 V DC 48 kΩ @ 48 V DC 60 kΩ @ 60 V DC	110 kΩ @ 110 V DC 220 kΩ @ 220 V DC

IMPORTANT

PSR2+ modules can be used only if the power consumption of the device does not reach 20 W and maximum 2 contacts are needed. If the application does not meet any of these two requirements it is not allowed to use these cards. In this case separate PS+ (Chapter 16) and Signaling (Chapter 8) modules must be used.

1.3.20.2. PSR2+ module

Connector types:

- The default and optionally available connector types are indicated for each module in the table below. See Chapter 20.2 for details about each type.

MODULE TYPE	PSR2+/2101
POWER SUPPLY CHARACTERISTICS	
RATED VOLTAGE	110 V / 220 V
INPUT VOLTAGE OPERATIVE RANGE	88 - 264 V DC 80 - 250 V AC
MAXIMUM CONTINUOUS POWER OUTPUT	20 W
VOLTAGE DIP DURATION AT 0% RESIDUAL VOLTAGE (IEC 60255-26)	min. 100 ms in the specified input voltage range
INTERNAL FUSE	3.15A/250V
CONNECTOR TYPE	<u>Default:</u> BLA <u>Options:</u> T
SIGNALING RELAY CHARACTERISTICS	
CHANNEL NUMBER	2
RATED VOLTAGE	250 V AC/DC
CONTINUOUS CARRY	8 A
MAKING CAPACITY	0.5 s, 30 A
CONNECTOR TYPE	<u>Default:</u> BLA <u>Options:</u> T

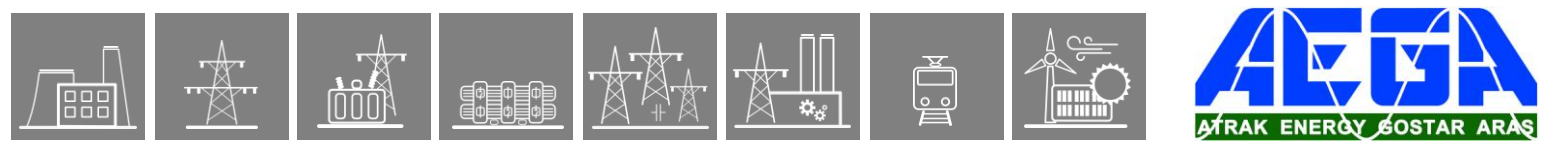

Main features (according to IEC 60255-26):

- Maximum switching voltage: 400 V AC
- Breaking capacity: (L/R=40 ms) at 220 V DC: 0.2 A, at 110 V DC: 0.3 A
- Breaking capacity max.: 2000 VA
- Short time carrying capacity: 1 s, 35 A
- Limiting making current, max. 4 s: 15 A (df = 10 %)
- Dielectric strength between open contacts, 1 min: 1000 V_{RMS}
- Mechanical endurance: 10 × 10⁶ cycles
- Circuit closing capability: typically 10 ms, maximally 22 ms.
- Bounce time: typically 6,5 ms, maximally 10 ms.
- Minimal switching requirement: 5 V

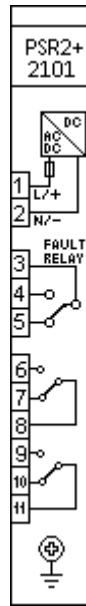
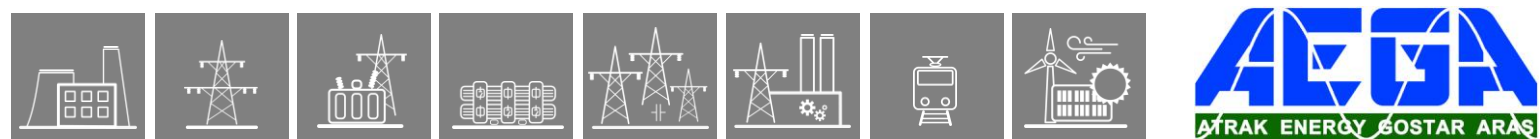

Figure 18-2 Power supply with 2 Ch. signaling modules



1.3.20.3. O6R5+ module

The O6R5+ module contains 6 binary input channels in one grounding group, and 5 relay outputs with 2 × 2 NO contacts and one CO contact.

Connector types:

- The default and optionally available connector types are indicated for each module in the tables below. See Chapter 20.2 for details about each type.

Notes for the following table:

- **Thermal withstand voltage:** continuous with 60 % of the input channels are energized.
- **Clamp voltage:** these are the guaranteed values; the actual ones might differ from those provided here (falling and rising around 0.66 U_N and 0.77 U_N , respectively)

MODULE TYPE	O6R5+/2101	O6R5+/4201
BINARY INPUT CHARACTERISTICS		
CHANNEL NUMBER	6	6
RATED VOLTAGE	110 V / 220 V user selectable on channel basis by jumpers	24 V / 48 V user selectable on channel basis by jumpers
TIME SYNCHRONIZATION	configured by EuroCAP	configured by EuroCAP
THERMAL WITHSTAND VOLTAGE	320 V	72 V
CLAMP VOLTAGE	falling 0.64 U_N rising 0.8 U_N	falling 0.64 U_N rising 0.8 U_N
COMMON GROUPS	1 × 6 common	1 × 6 common
RELAY OUTPUT CHARACTERISTICS		
RATED VOLTAGE	250 V AC/DC	250 V AC/DC
CONTINUOUS CARRY	8 A	8 A
CONTACT VERSIONS	4 NO, 1 CO	4 NO, 1 CO
GROUP ISOLATION	2 × 2 common, 1 independent	2 × 2 common, 1 independent
CONNECTOR TYPE FOR BOTH BINARY INPUT AND RELAY OUTPUT	<u>Default:</u> BLA <u>Options:</u> T	<u>Default:</u> BLA <u>Options:</u> T

Main features for binary inputs:

- Digitally filtered per channel
- Current drain:
 - max. 1.6 mA per channel at 220 V DC
 - max. 1.8 mA per channel at 110 V DC
 - max. 2 mA per channel at 48 V DC
 - max. 3 mA per channel at 24 V DC
- In such applications where the input voltage is 60 V the modules with 48 V rated voltage can be used.
- Input voltage type can be either DC or AC voltage. If AC voltage is used make sure that the type and the parameters of the binary inputs are configured properly in EuroCap tool.

Main features for signaling outputs:

- Maximum switching voltage: 400 V AC
- Breaking capacity, (L/R=40 ms) at 220 V DC: 0.1 A, at 110 V DC: 0.2 A
- Breaking capacity max.: 2000 VA
- Short time carrying capacity: 1 s, 35 A
- Limiting making current, max. 4 s: 15 A (df = 10 %)
- Initial dielectric strength between open contacts, 1 min: 1000 V_{RMS}
- Circuit closing capability: typically 10 ms, maximally 22 ms.
- Bounce time: typically 6,5 ms, maximally 10 ms.
- Mechanical endurance: 10 × 10⁶ cycles
- Circuit closing capability

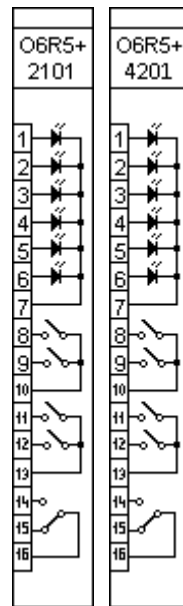

Figure 18-3 Binary input/output modules

1.3.20.4. Binary input module with time synchronization

The inputs are galvanically isolated and the module converts high-voltage signals to the voltage level and format of the internal circuits. This module is also used as an external IRIG-B synchronization (**IRIG-B000, unmodulated**), PPM or PPS input. Dedicated synchronization input is used for this purpose.

Connector types:

- The default and optionally available connector types are indicated for each module in the tables below. See Chapter 20.2 for details about each type.

Notes for the following table:

- **Thermal withstand voltage:** continuous with 60 % of the input channels are energized.
- **Clamp voltage:** these are the guaranteed values; the actual ones might differ from those provided here (falling and rising around $0.66 U_N$ and $0.77 U_N$, respectively)

MODULE TYPE	O9S+/2111	O9S+/2121	O9S+/4221
CHANNEL NUMBER	9	9	9
SYNCHRON CHANNEL TYPE AND NUMBER	1 isolated BNC connector	1 850 nm multimode fiber with ST connector	1 850 nm multimode fiber with ST connector
RATED VOLTAGE	110 V DC / 220 V DC user selectable by jumpers	110 V DC / 220 V DC user selectable by jumpers	24 V DC / 48 V DC user selectable by jumpers
THERMAL WITHSTAND VOLTAGE	320 V	320 V	72 V
WITHSTAND VOLTAGE FOR SYNC. INPUT	35 V _{PEAK}	-	-
CLAMP VOLTAGE	falling $0.64 U_N$ rising $0.8 U_N$	falling $0.64 U_N$ rising $0.8 U_N$	falling $0.64 U_N$ rising $0.8 U_N$
COMMON GROUPS	9 (3 × 3 common)	9 (3 × 3 common)	9 (3 × 3 common)
CONNECTOR TYPE	<u>Default:</u> BLA <u>Options:</u> T	<u>Default:</u> BLA <u>Options:</u> F, T	<u>Default:</u> - <u>Options:</u> F, T

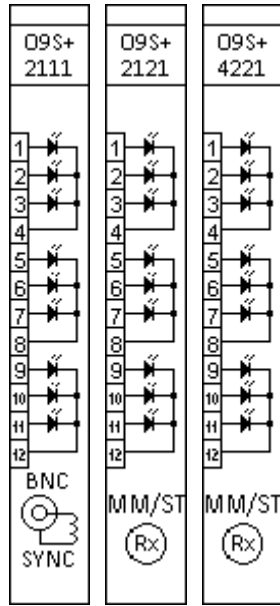

Figure 18-4 Binary input modules with time synchronization

1.3.20.5. Externally driven trip module

The R4MC+01 is a special TRIP module, which can be operated from the connector side. It also has two diode inputs with cathodes which are connected and led to the connector side.

Connector types:

- The default and optionally available connector types are indicated for each module in the tables below. See Chapter 20.2 for details about each type.

Module type	R4MC+/01*
CHANNEL NUMBER	2
RATED VOLTAGE	110 V DC
THERMAL WITHSTAND VOLTAGE	132 V DC
CONTINUOUS CARRY	8 A
MAKING CAPACITY	0.5 s, 30 A
BREAKING CAPACITY	L/R = 40 ms: 4 A DC
DIODE PROPERTIES	1 A, 1000 V DC
CONNECTOR TYPE	<u>Default:</u> BLA <u>Options:</u> F

*Special module



Figure 18-5 Externally driven TRIP module

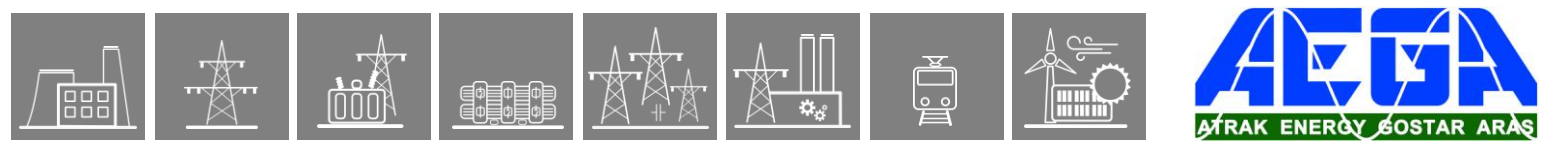

1.3.21. General data

- Storage temperature: - 40 °C ... + 70 °C
- Operation temperature: - 20 °C ... + 55 °C
- Humidity: 10 % ... 93 %
- Altitude: up to 2000 m
- Atmospheric pressure: 86 ... 106 kPa

1.3.21.1. Standard conformance

- Electrostatic discharge immunity (ESD), IEC-EN 60255-26:2013, Level 4
 - Test voltages: 15 kV air discharge, 8 kV contact discharge
- Radiated, radio-frequency, electromagnetic field immunity, IEC-EN 60255-26:2013 Level 3
 - Test field strength: 10 V/m
- Electrical fast transient/burst immunity (EFT/B), IEC-EN 60255-26:2013, Level 4
 - Test voltage: 4 kV
- Surge immunity test, IEC-EN 60255-26:2013
 - Test voltages: 4 kV line-to-earth, 2 kV line-to-line
- Immunity to conducted disturbances, induced by radio-frequency fields, IEC-EN 60255-26:2013, Level 3
 - Test voltage: 10 V
- Damped oscillatory wave immunity test, IEC-EN 60255-26:2013
 - Test frequency: 1 MHz
 - Test voltage: 2.5 kV in common mode, 1 kV in differential mode
- Voltage dips, short interruptions and voltage variations immunity, IEC-EN 60255-26:2013
 - Voltage dips: 40 % (200 ms), 70 % (500 ms), 80 % (5000 ms)
- Ripple on d.c. input power port immunity, IEC-EN 60255-26:2013
 - Level 4, 15 % of rated d.c. value
- Power frequency magnetic field immunity test, IEC-EN 60255-26:2013, Level 5
 - Test field strength: 100 A/m continuous, 1000 A/m for 3 s
- Power frequency immunity test on the binary inputs, IEC-EN 60255-26:2013, Class A
 - Test voltages: 300 V in common mode, 150 V in differential mode
- Insulation tests, IEC-EN 60255-27:2013
 - Impulse voltage test
 - Test levels: 5 kV (1 kV for transducer and temperature measuring inputs)
 - Dielectric test
 - Test levels: 2 kV AC 50 Hz (0.705 kV DC for transducer inputs)
 - Insulation resistance
 - Insulation resistance > 15 GΩ
- Radiated emission, IEC-EN 60255-26:2013

Limits:

 - 30 MHz to 230 MHz: 50 dB(μV/m) quasi peak, 3 m
 - 230 MHz to 1 000 MHz: 57 dB(μV/m) quasi peak, 3 m
 - 1 GHz to 3 GHz: 76 dB(μV/m) peak, 3 m
 - 3 GHz to 6 GHz: 80 dB(μV/m) peak, 3 m
- Conducted emission, IEC-EN 60255-26:2013

Limits:

 - 0,15 MHz to 0,50 MHz: 79 dB(μV) quasi peak, 66 dB(μV) average
 - 0,5 MHz - 30 MHz: 73 dB(μV) quasi peak, 60 dB(μV) average
- Vibration, shock, bump and seismic tests on measuring relays and protection equipment
 - Vibration tests (sinusoidal), Class I, IEC 60255-21-1:1988
 - Shock and bump tests, Class I, IEC 60255-21-2:1988
 - Seismic tests, Class I, IEC 60255-21-3:1993

1.3.22. Mechanical data

1.3.22.1. General mechanical data

- Construction: chromate aluminum surface with built-in EMC accessories

- If the power consumption of a 84 HP or 42 HP device does not exceed 30 W (84 HP) or 14 W (42 HP), the construction will be built with solid top and bottom cover panels.
 - If the power consumption exceeds 30 W (84 HP) or 14 W (42 HP), the construction will be built with (honeycomb) perforated top and bottom cover panels.
- EMC rack protects against electromagnetic environmental influences and protects the environment from radiation from the interior
- IP protection:
 - 24 HP panel instrument case: IP4x; optionally IP54 (front)
 - 84 HP and 42 HP (including double) rack: IP4x from front side, IP2x from rear side; optionally IP54 (front)
- Size:
 - 19" (84 HP), 3 U, single rack
 - ½ 19" (42 HP), 3 U, single rack
 - ½ 19" (42 HP), 6 U, double rack
 - 24 HP, panel instrument case
- Weight:
 - 84 HP: max. 8 kg
 - 42 HP, 3 U: max. 4.5 kg
 - 42 HP, 6 U: max. 8 kg
 - 24 HP: max. 3 kg

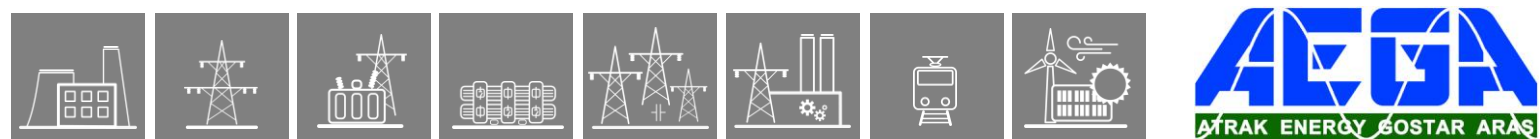

1.3.22.2. Connectors

Optionally, certain modules can be equipped with different terminals for different connectors. The available choices are listed among each module's technical data with their *short ID* (see the first column of the table below).

The type of the used terminal is indicated on the module's label with its *short ID* (see the following example). The actual type of the connector is chosen according to the number of the available pins of the module.

Example: the *VT+/2211* module may have four types of connectors. In its description (Chapter 6), these are indicated with their ID:

- The default terminal is indicated with nothing attached (*VT+/2211*), only its name (BLA) is mentioned. Since it has 8 pins, the type is BLA 8/180
- The flanged terminal's *short ID* is **F**, so the module's label will be "*VT+/2211F*", if it is equipped with this terminal (BLA 8B/180)
- Top-screw terminal: **T**, the label becomes "*VT+/2211T*" (BLT 5.08HC/08/180F)
- Ring-lug terminal: **R**, so the module's label shall be "*VT+/2211R*"

CONNECTOR NAME (SHORT ID)	CONNECTOR TYPES	STRIP LENGTH [MM]	CONDUCTOR AREA [MM ²]	CONDUCTOR DIAMETER [MM]	TIGHTENING TORQUE [Nm]	MINIMUM BEND RADIUS*
BLA (-)	Weidmüller BLA 2/180, BLA 3/180, BLA 4/180, BLA 6/180, BLA 8/180, BLA 10/180, BLA 12/180, BLA 13/180, BLA 16/180	7	0.2 – 1.5 solid: 0.2 – 2.5	0.5 – 1.4 solid: 0.5 – 1.8	0.4 – 0.5	3 × OD**
BL 3.5 (-)	Weidmüller BL 3.5/05/180 BL 3.5/09/180	6	0.2 – 1.5	0.5 – 1.4	0.2 – 0.25	3 × OD**
FLANGED (F)	Weidmüller BLA 2B/180, BLA 3B/180, BLA 4B/180, BLA 6B/180, BLA 8B/180, BLA 10B/180, BLA 12B/180, BLA 16B/180	7	0.2 – 1.5 solid: 0.2 – 2.5	0.5 – 1.4 solid: 0.5 – 1.8	0.4 – 0.5	3 × OD**
TOP-SCREW (T)	Weidmüller BLT 5.08HC/06/180F, BLT 5.08HC/08/180F, BLT 5.08HC/12/180F, BLT 5.08HC/16/180F	13	0.2 – 1.5 solid: 0.2 – 2.5	0.5 – 1.4 solid: 0.5 – 1.8	0.4 – 0.5	3 × OD**
RING-LUG (R)	TE Connectivity BC6-Q308-08	-	0.33 – 3.31	0.65 – 2.05	0.79	3 × OD**

* Bend radius is measured along the inside curve of the wire or wire bundles.

** OD is the outer diameter of the wire or cable, including insulation.



CONNECTOR NAME (SHORT ID)	CONNECTOR TYPES	STRIP LENGTH [MM]	CONDUCTOR AREA [MM ²]	CONDUCTOR DIAMETER [MM]	TIGHTENING TORQUE [Nm]	MINIMUM BEND RADIUS*
STVS (-)	Weidmüller STVS 6 SB, STVS 8 SB	9	0.5 – 4	0.8 – 2.3	0.5 – 0.6	3 × OD**
B2L 3.5	Weidmüller B2L 3.5	7	0.2 – 1	0.5 – 1.1	tension clamp connection	3 × OD**
ST/FC/LC	Bayonet/Screw/Snap Fiber Optic	-	-	-	-	30 mm
PE FASTON TERMINAL	TE Connectivity 6.3x0.8	7	min. 4	min. 2.3	-	3 × OD**

* Bend radius is measured along the inside curve of the wire or wire bundles.

** OD is the outer diameter of the wire or cable, including insulation.

The tightening torque of the screw for protective earth connection and the wall mounting must be approx. 5 Nm.

The tightening torque of the screw for fastening the STVS connector must be approx. 1 Nm.

The minimum distance between an EP+ device and its wire channel must be at least 3 cm.

The minimum distance between two EP+ devices must be at least 10 cm.

During the installation make sure that the shortest possible length for PE (Protective Earth) cable routing is applied.

1.3.23. Mounting methods

- Flush mounting
 - 84 HP single rack
 - 42 HP single rack
 - 42 HP double rack
 - 24 HP panel instrument case
 - Remote HMI
- Rack mounting
 - 84 HP single rack
 - 42 HP single rack
 - Remote HMI
- Semi-flush mounting
 - 84 HP single rack
 - 42 HP single rack
 - 24 HP panel instrument case
 - Remote HMI
- Wall mounting (with terminals)
 - 84 HP single rack
 - 42 HP single rack
- Din rail mounting
 - 24 HP panel instrument case
- IP54 rated mounting
 - 84 HP single rack
 - 42 HP single rack
 - 24 HP panel instrument case (original frame with additional gasket)
- Fold-down mounting (with optional terminals)
 - 84 HP single rack
 - 42 HP single rack
- No mounting
 - 84 HP single rack
 - 42 HP single rack

MOUNTING METHOD	84 HP SINGLE RACK	42 HP SINGLE RACK	42 HP DOUBLE RACK	24 HP PANEL INSTRUMENT CASE	REMOTE HMI
FLUSH MOUNTING	X	X	X	X	X
RACK MOUNTING	X	X			X
SEMI-FLUSH MOUNTING	X	X		X	X
WALL MOUNTING (WITH TERMINALS)	X	X			
DIN RAIL MOUNTING				X	
IP54 RATED MOUNTING	X	X		X*	
FOLD-DOWN MOUNTING	X	X			

**additional gasket inserted into the original front panel frame*



It is recommended to leave at least 80 mm free space for the wiring at the back of the IED in case of Flush mounting, Rack mounting, and Semi-flush mounting.

1.3.23.1. Flush mounting

Flush mounting can be used for all size of racks (84 HP, 42 HP, double 42 HP) including the 24 HP panel instrument case and the remote HMI devices. When this type of mounting alternative is used the 84 HP, 42 HP, double 42 HP and remote HMI devices have got a cover profile fit on and the 24 HP devices have got a mounting frame fit on.

The dimensions of the cut-outs for the 84 HP and 42 HP devices are also applicable for the same sized remote HMI devices.

1.3.23.1.1. Flush mounting of 84 HP and 42 HP single rack

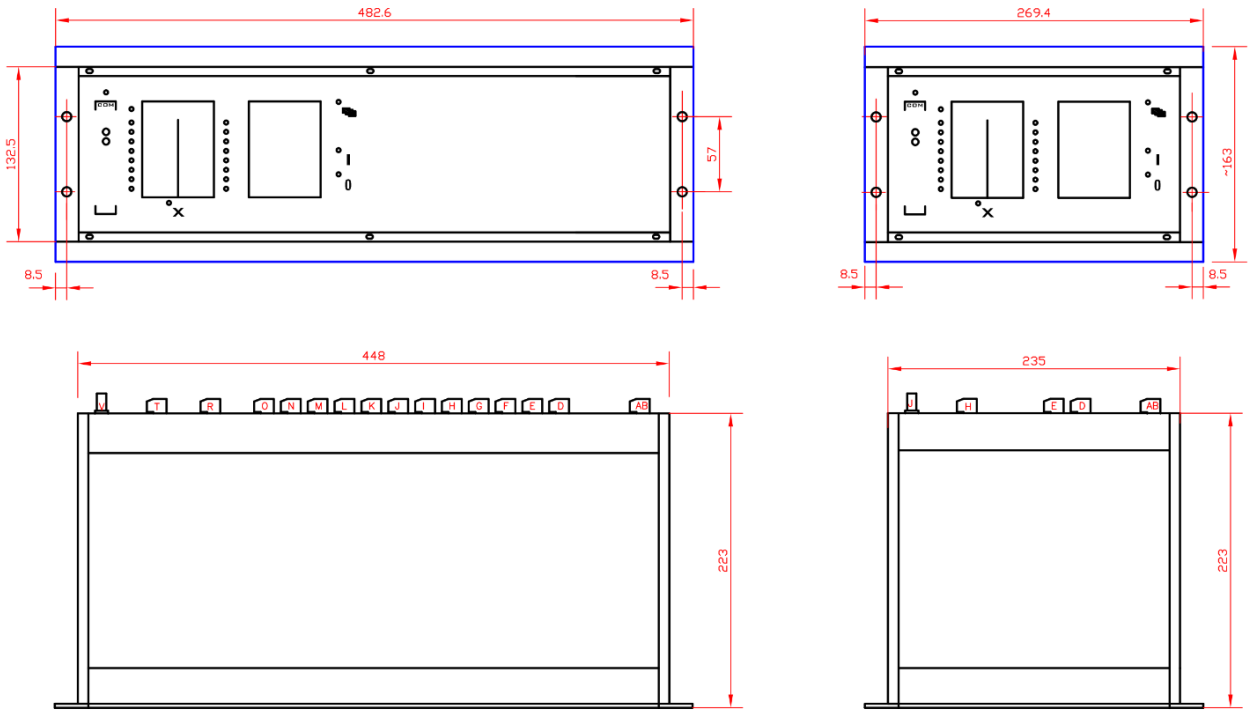

PANEL CUT-OUT

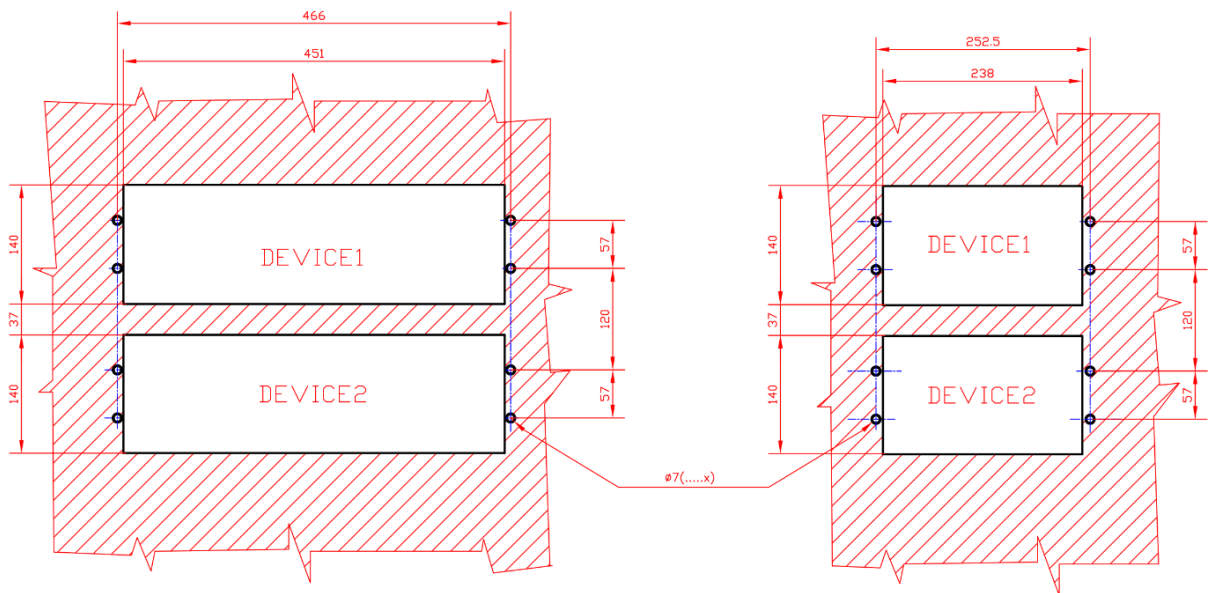

Figure 21-1 Dimensions for flush mounting of 84 HP and 42 HP single rack

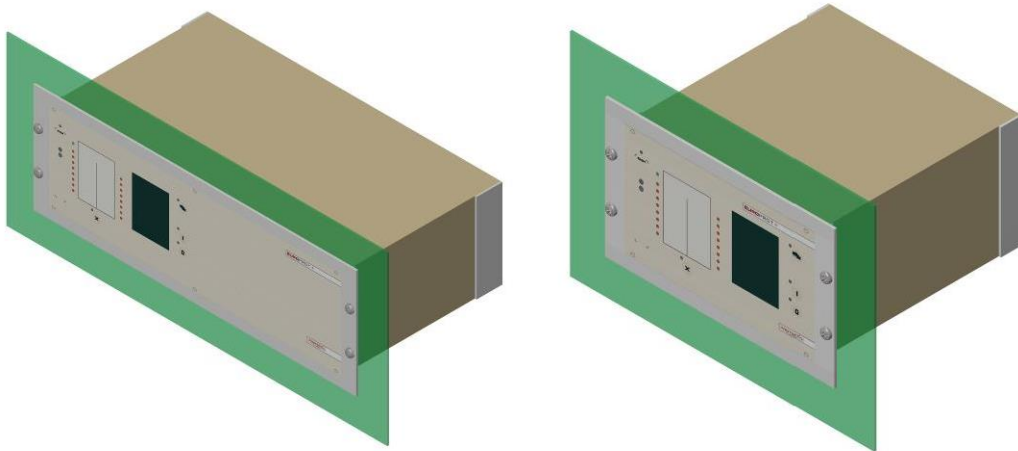

Figure 21-2 3D illustration for flush mounting of 84 HP and 42 HP devices

1.3.23.1.2. Flush mounting of 42 HP double rack

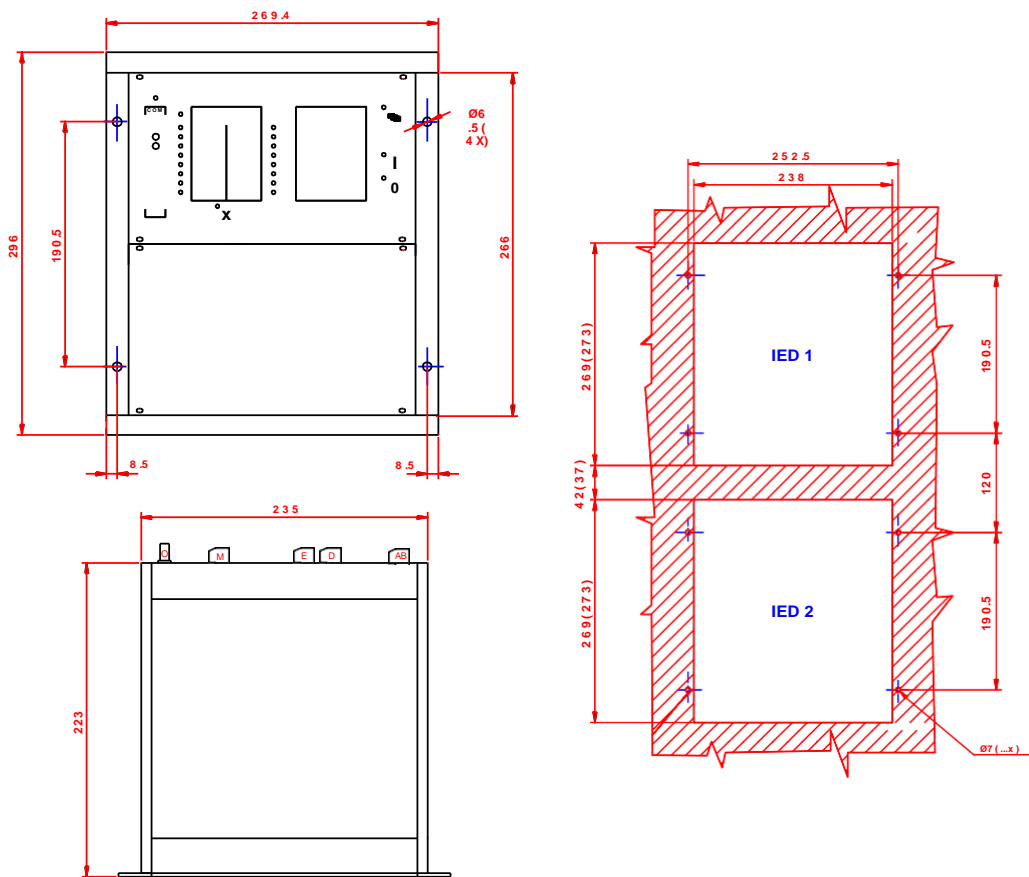

Figure 21-3 Dimensions for flush mounting of 42 HP double rack

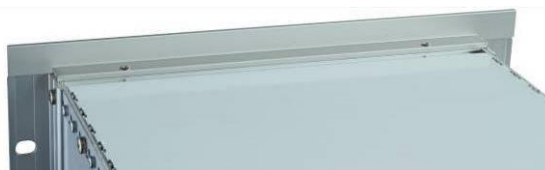

Figure 21-4 42 HP wide cover profile

1.3.23.1.3. Flush mounting of 24 HP panel instrument case

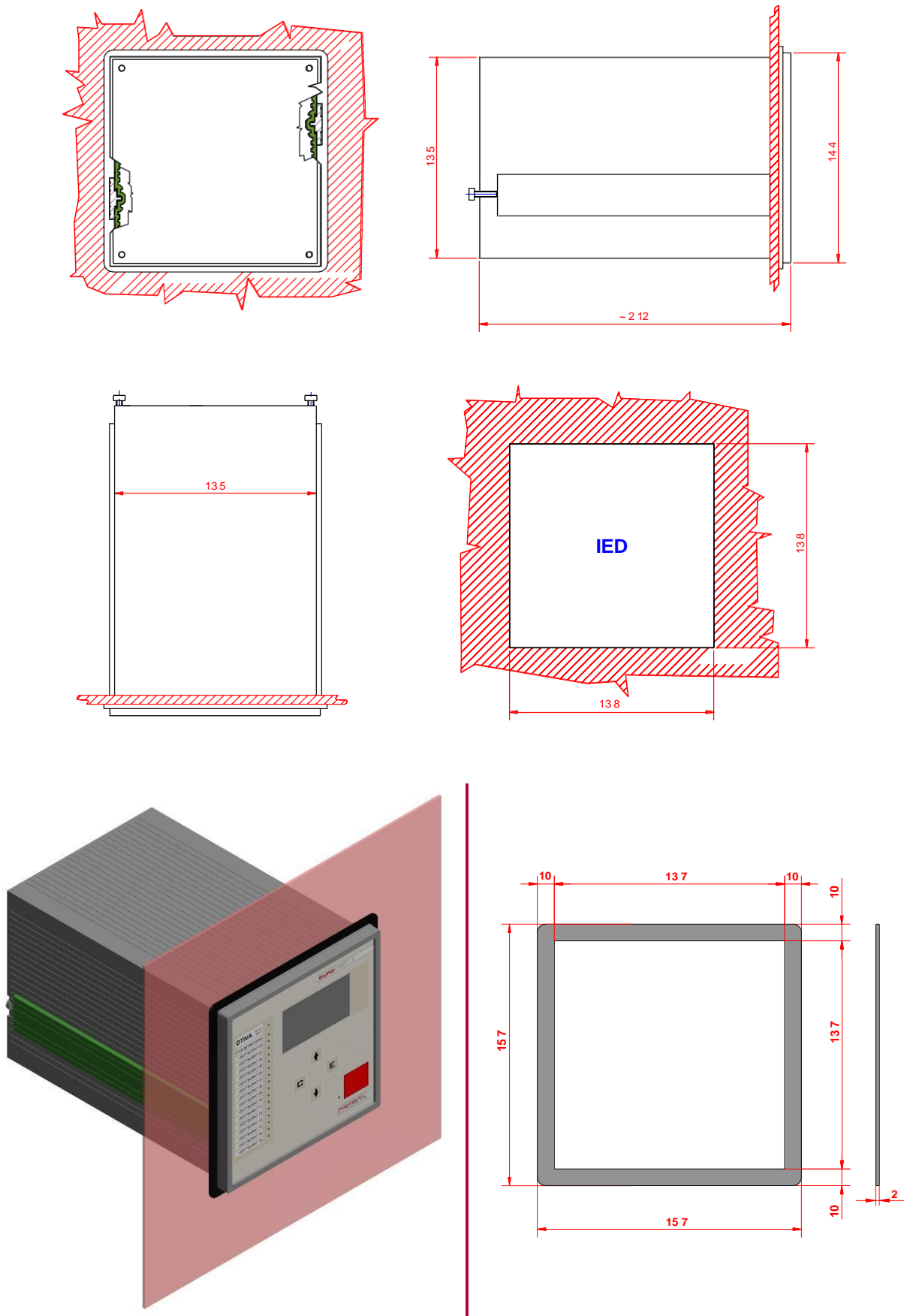

Figure 21-5 Dimensions for flush mounting of 24 HP panel instrument case with 3D illustration

1.3.23.2. Rack mounting

When rack mounting is used, the devices do not have a cover profile fit on, so it is possible to mount them in a 19" rack.

1.3.23.2.1. Rack mounting of 84 HP and 42 HP single rack

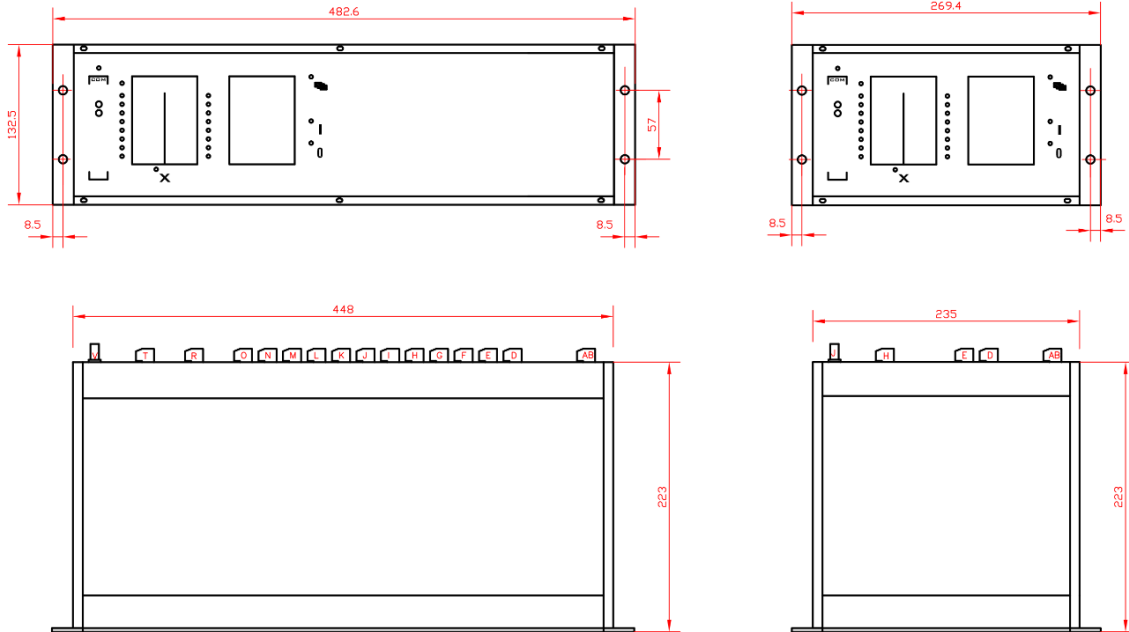

Figure 21-6 Dimensions for rack mounting of 84 HP and 42 HP single rack

Note that rack mounting type devices can also be mounted in a cut-out (e.g. on a switchgear door). It is possible to mount them from the front or from the back of the cut-out. The dimensions for rack mounting cut-outs are in the figure below. Dimensions in brackets are applicable in case of mounting from the back.

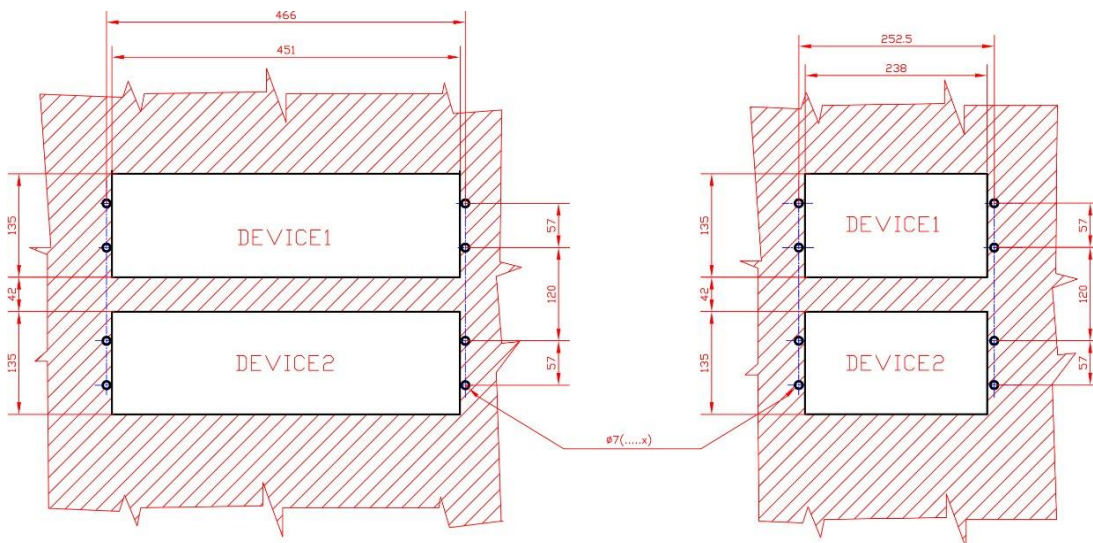
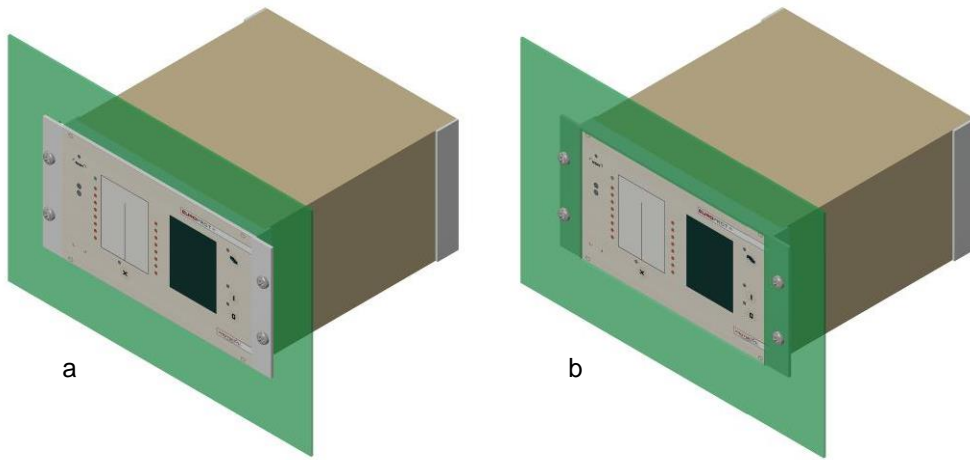
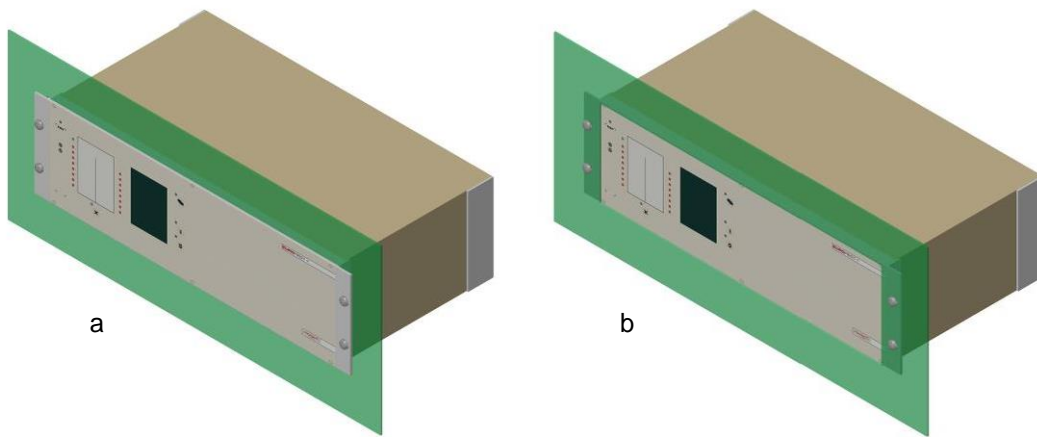

Figure 21-7 Dimensions of rack mounting cut-outs



*Figure 21-8 3D illustration for rack mounting of 42 HP device
(a - from the front; b - from the back)*



*Figure 21-9 3D illustration for rack mounting of 84 HP device
(a - from the front; b - from the back)*

1.3.23.2.2. Rack mounting of 42 HP double rack

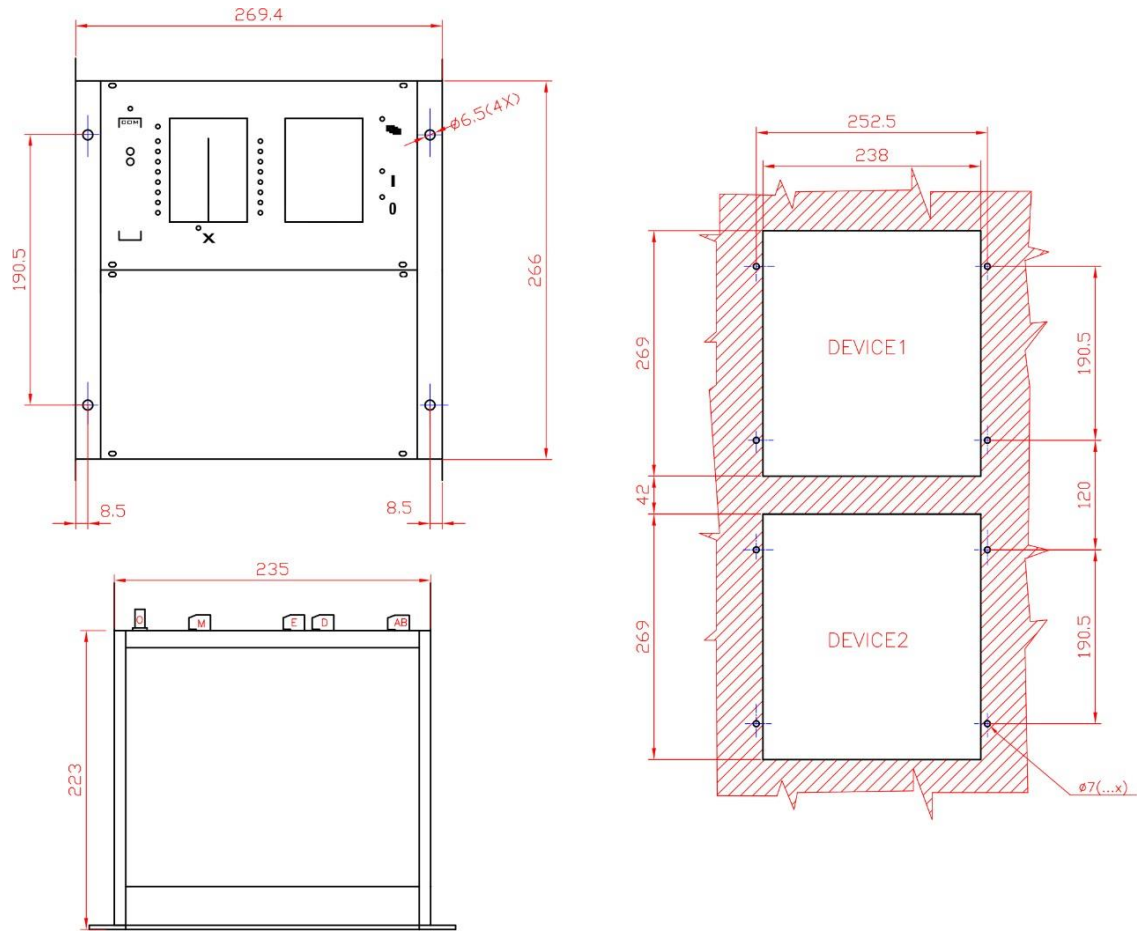

Figure 21-10 Dimensions for rack mounting of 42 HP double rack

1.3.23.3. Semi-flush mounting

Semi-flush mounting can be used for 84 HP and 42 HP single racks, for 24 HP panel instrument cases and for remote HMI devices. The purpose of this type of mounting alternative is to reduce the depth of the devices in the switchgear/rack if there is not enough space in that direction. To achieve this, a special mounting collar must be fit on the rack type devices. The default color of the mounting collar is grey (RAL 7035).

The dimensions of the special mounting collars and the cut-outs for the 84 HP and 42 HP devices are also applicable for the same sized remote HMI devices.

1.3.23.3.1. Semi-flush mounting of 84 HP single rack

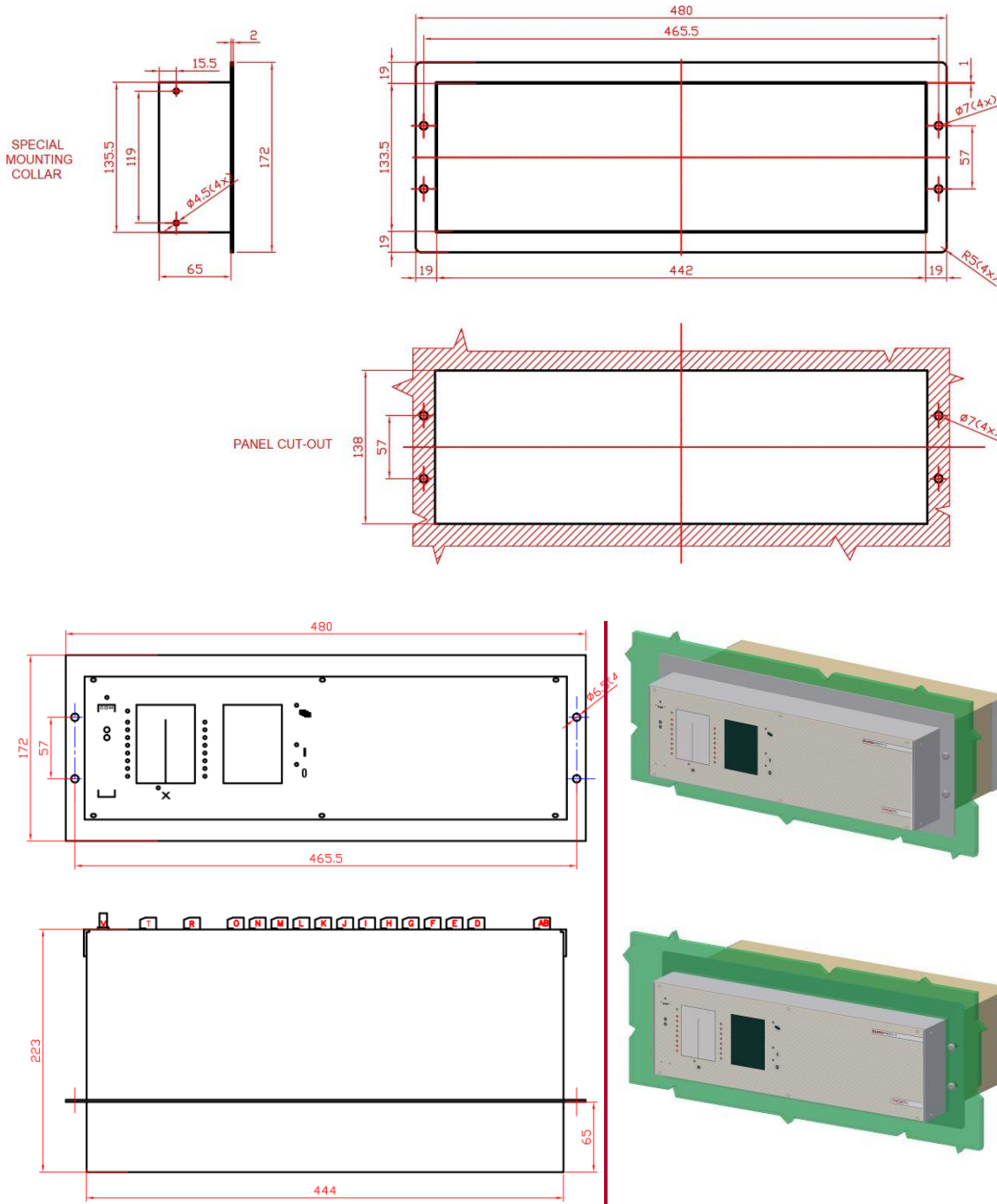

Figure 21-11 Dimensions for semi-flush mounting of 84 HP single rack with 3D illustration

1.3.23.3.2. Semi-flush mounting of 42 HP single rack

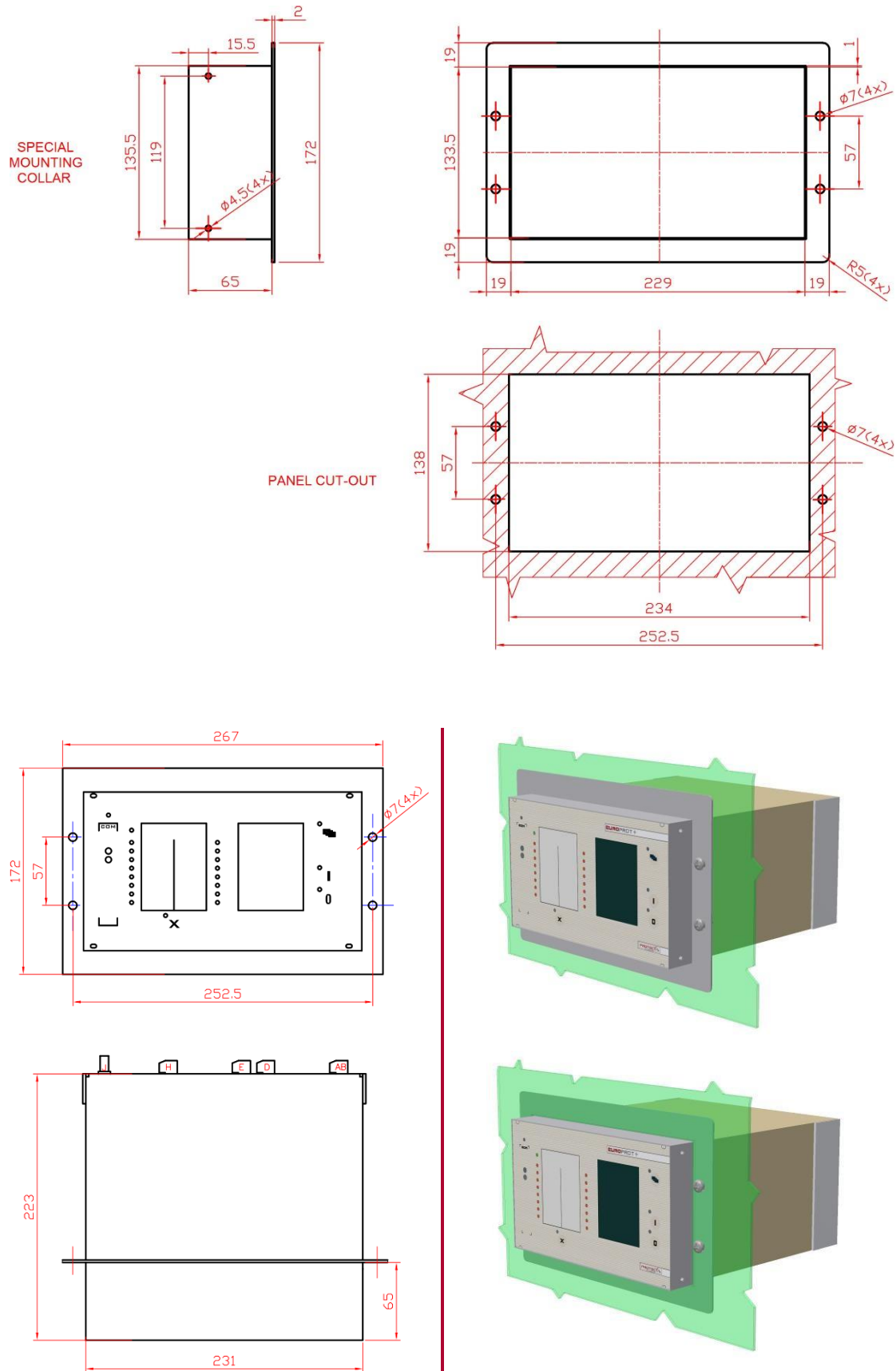
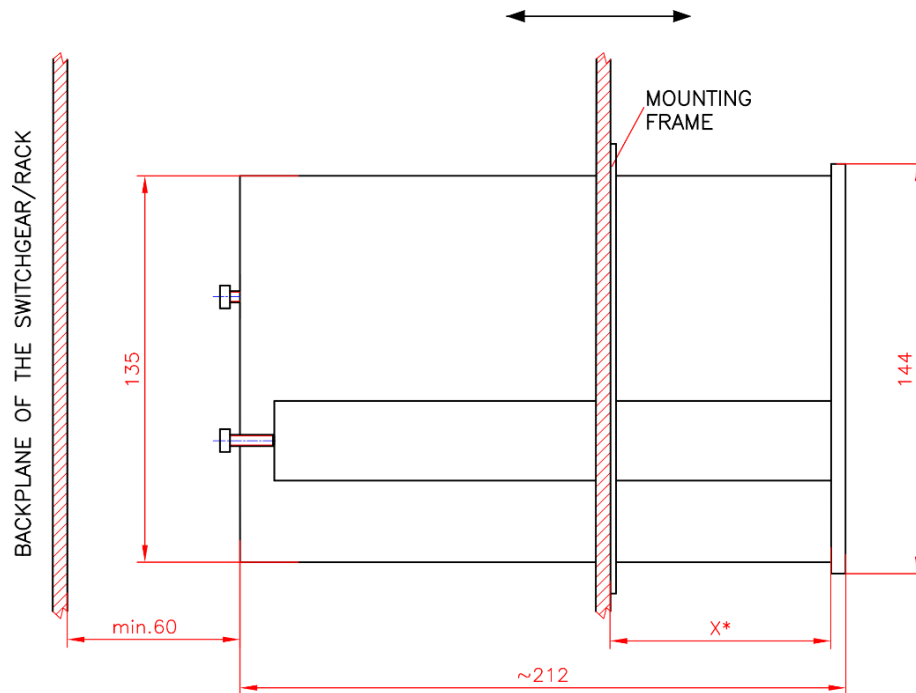

Figure 21-12 Dimensions for semi-flush mounting of 42 HP single rack with 3D illustration

1.3.23.3.3. Semi-flush mounting of 24 HP panel instrument case

The dimensions of the panel cut-out for this type of mounting method are the same as in case of flush mounting (138 mm x 138 mm). For semi flush mounting, it is enough to cut in two the fixing elements (with green colour in the 3D illustration below) and to make the assembly as shown in the pictures below.

Note that the IP54 front panel option cannot be utilized with this type of mounting.



*X: depending on the position of the cutting, the frame can be placed freely

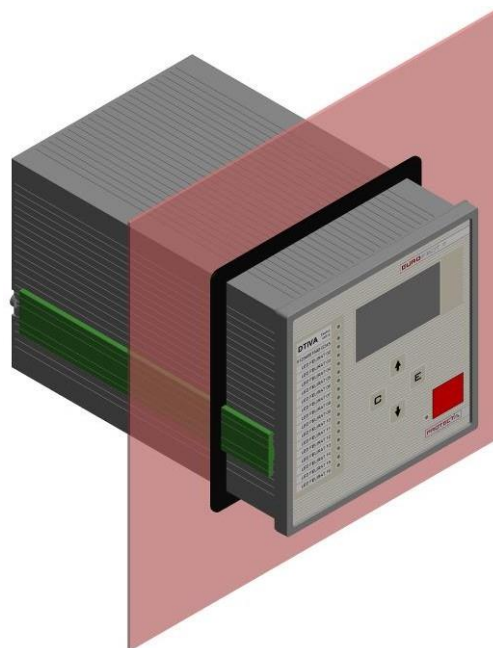

Figure 21-13 Dimensions for semi-flush mounting of 24 HP panel instrument case with 3D illustration

1.3.23.4. Wall mounting of 42 HP and 84 HP devices

Depending on the amount of the terminal contacts, it is possible to use both upper and lower terminals.

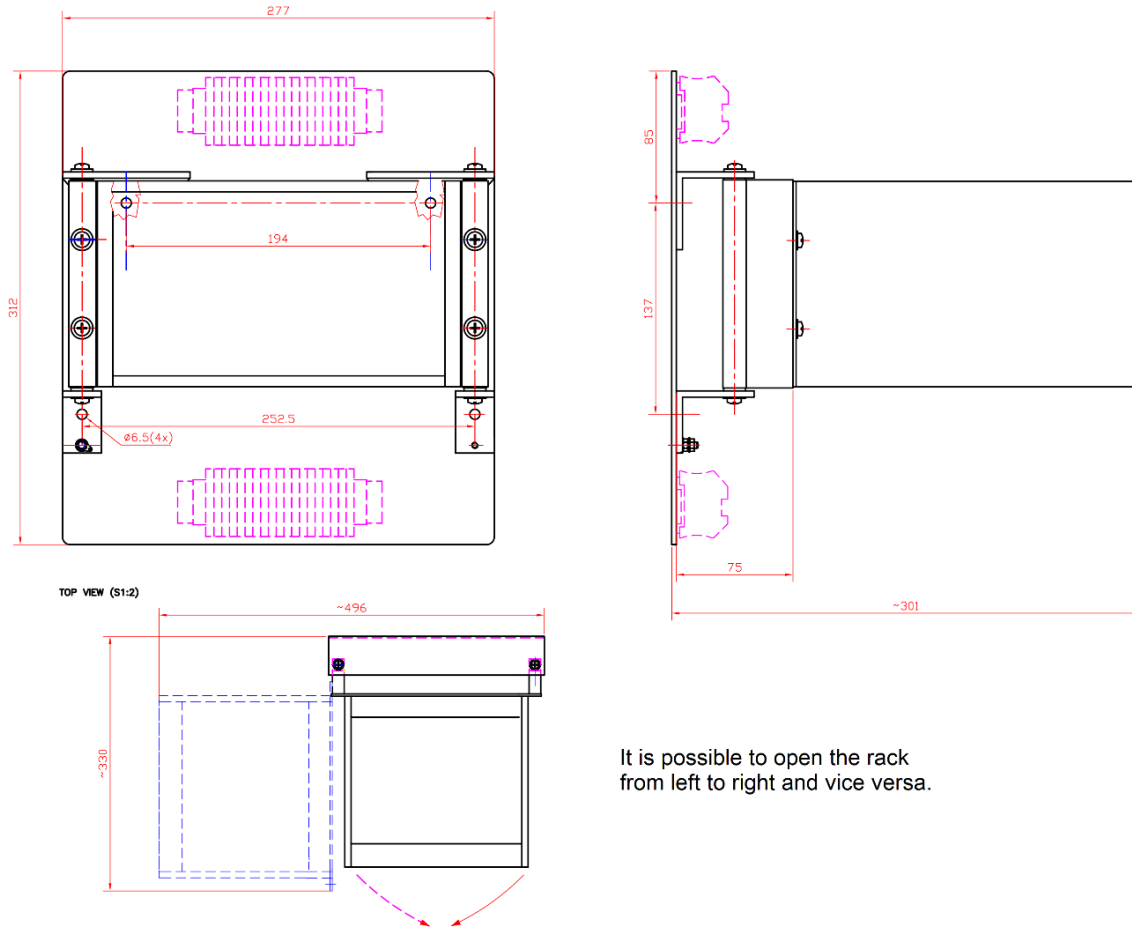

Figure 21-14 Dimensions for wall mounting of 42 HP devices (upper and lower terminals)

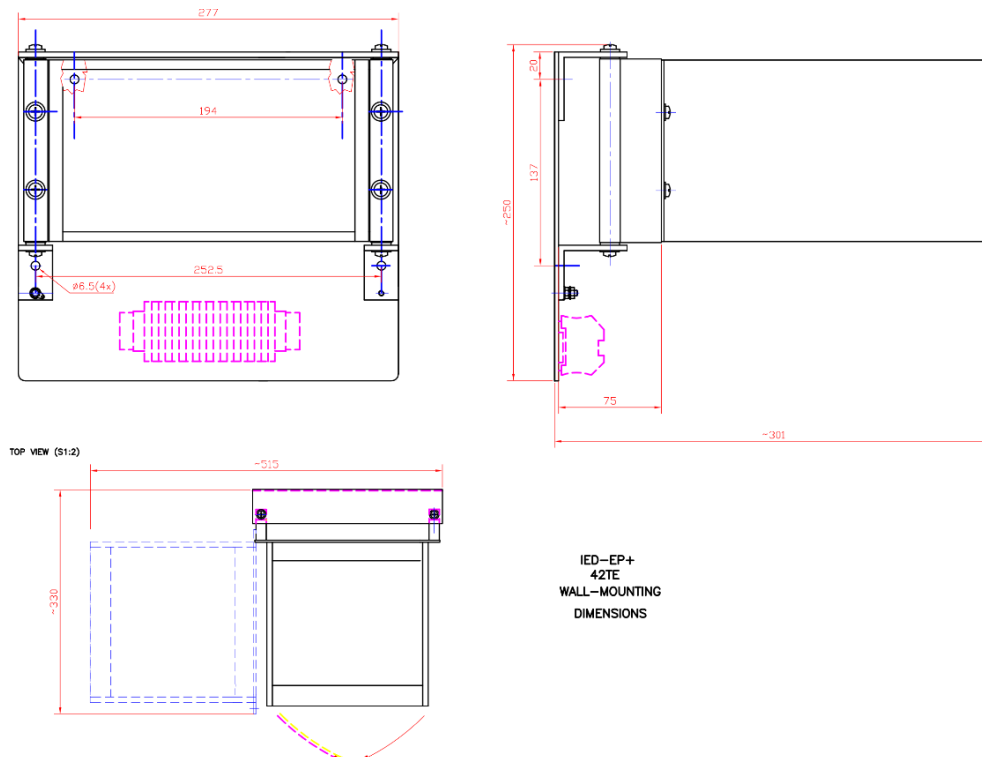

Figure 21-15 Dimensions for wall mounting of 42 HP devices (lower terminal only)

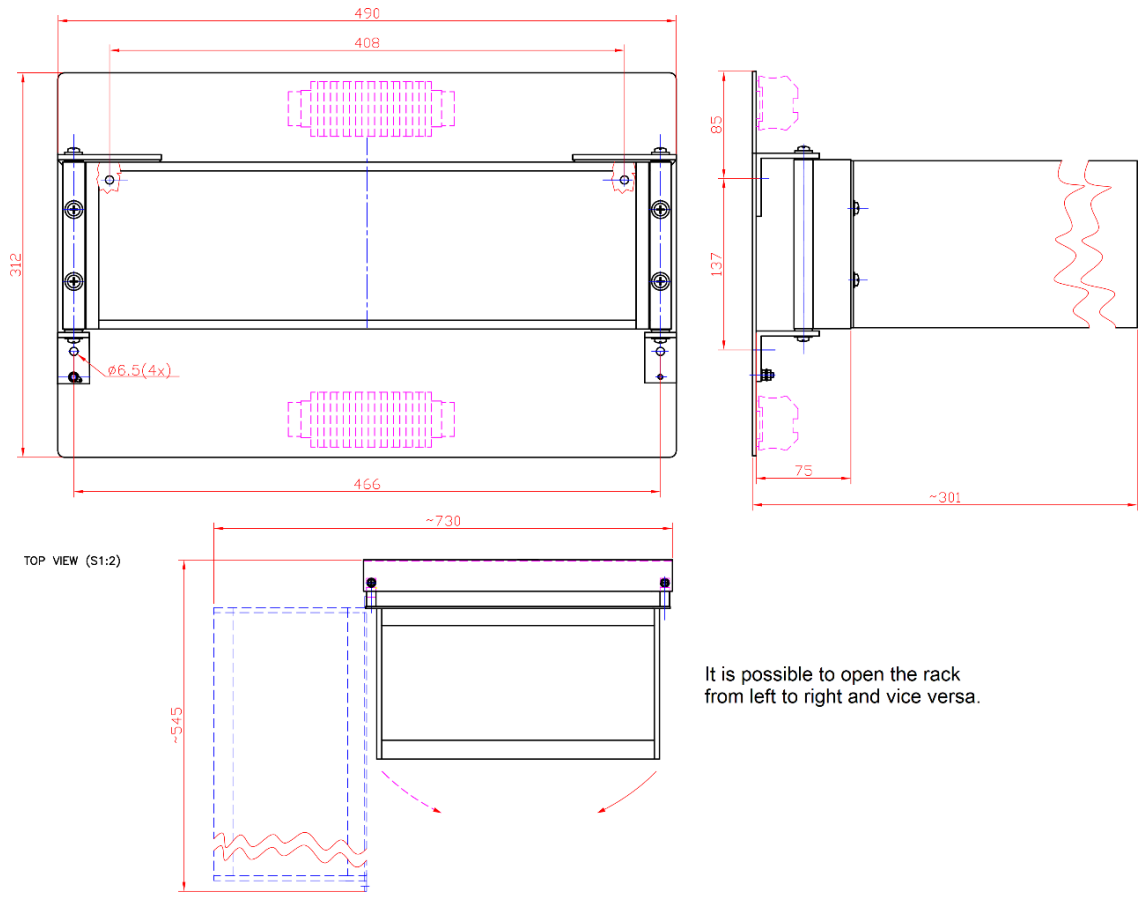

Figure 21-16 Dimensions for wall mounting of 84 HP devices (upper and lower terminals)

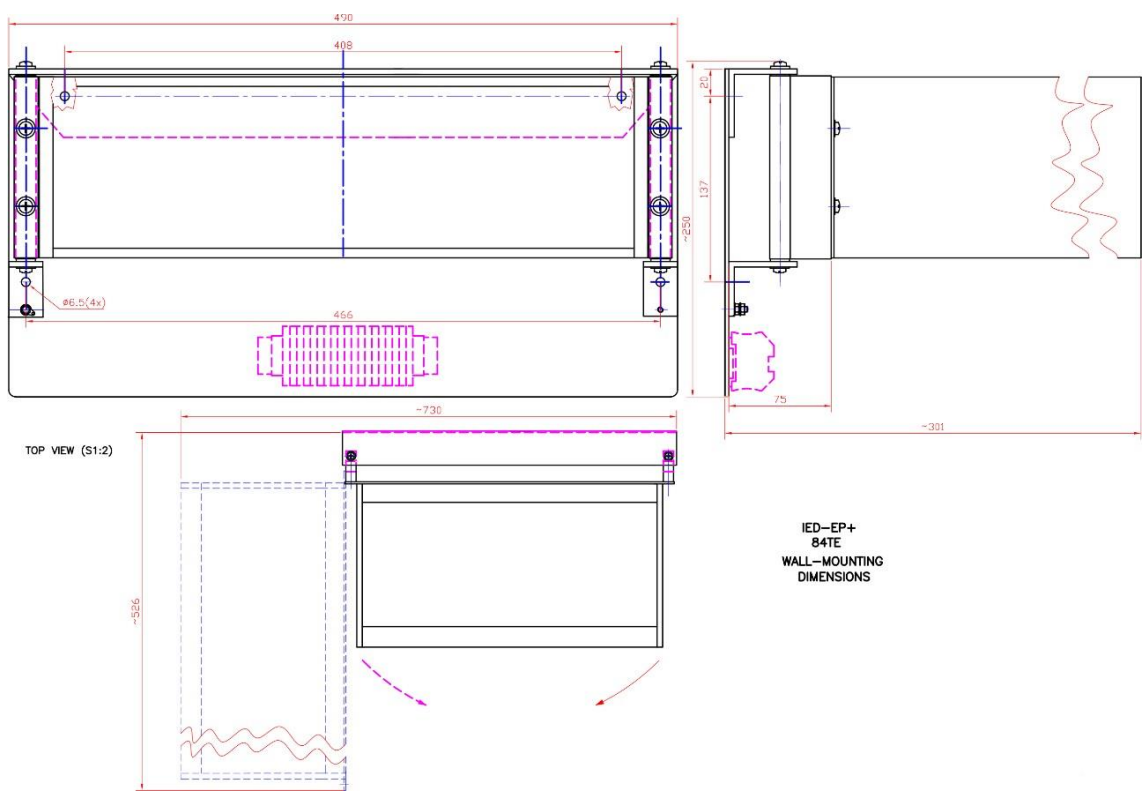

Figure 21-17 Dimensions for wall mounting of 84 HP devices (lower terminals only)

1.3.23.5. Din rail mounting of 24 HP panel instrument case

Note that the IP54 front panel option cannot be utilized with this type of mounting.

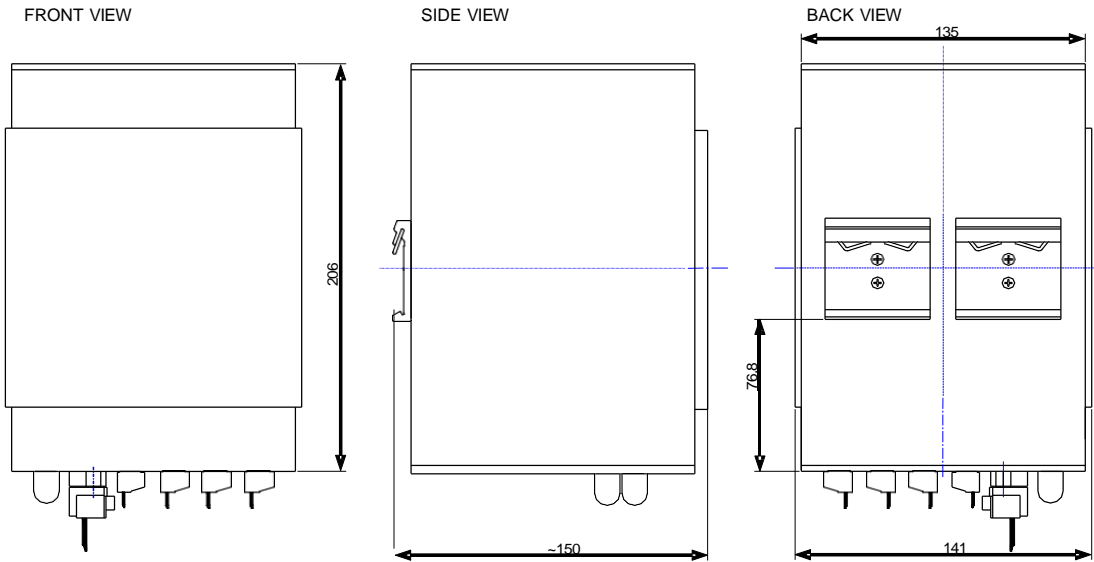

Figure 21-18 Dimensions for din rail mounting of 24 HP panel instrument case

1.3.23.6. IP54 rated mounting kit

The IP frame seen below provides IP54 protection from front side for 84HP and 42HP devices.

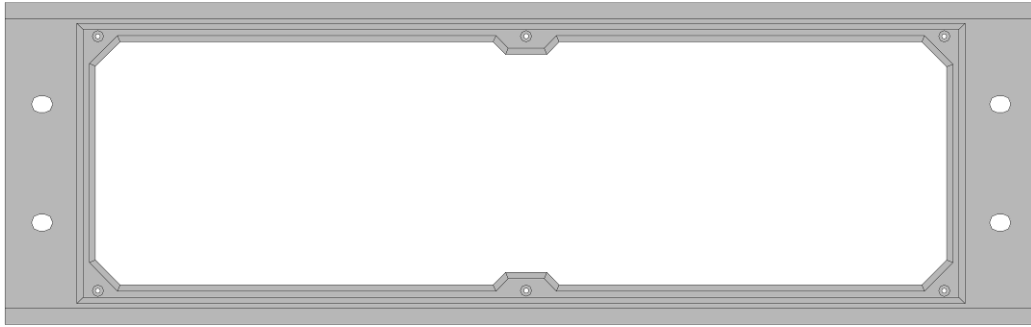

Figure 21-19 84 HP IP frame front view



Figure 21-20 42 HP IP frame front view

S24 devices

The S24 devices' front panel *does not differ from the normal front panel on the outside*, as there is IP54 gasket applied within the frame itself. Devices ordered with this option must be mounted by *flush mounting*; with other types of mountings (e.g. semi-flush), the IP54 protection is not guaranteed!

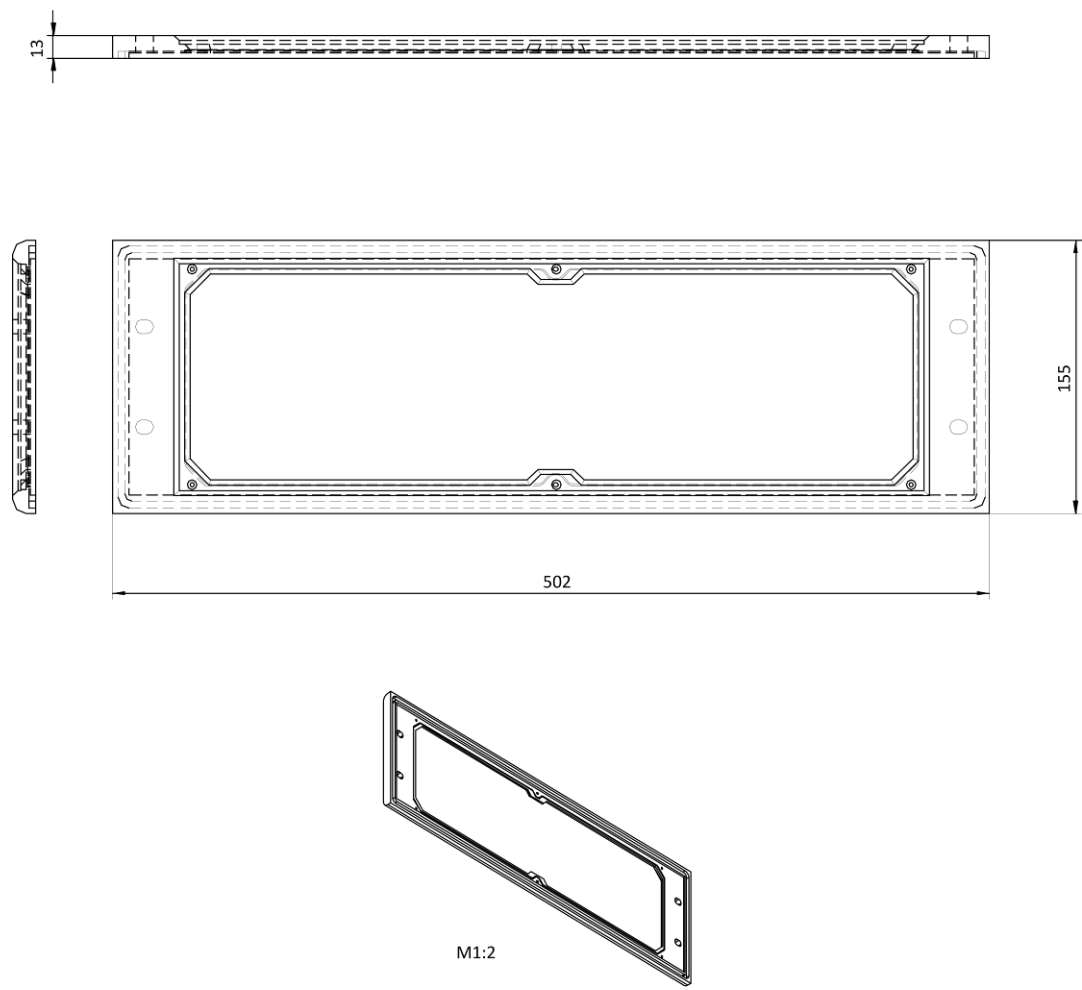

Figure 21-21: 84 HP IP frame dimensions

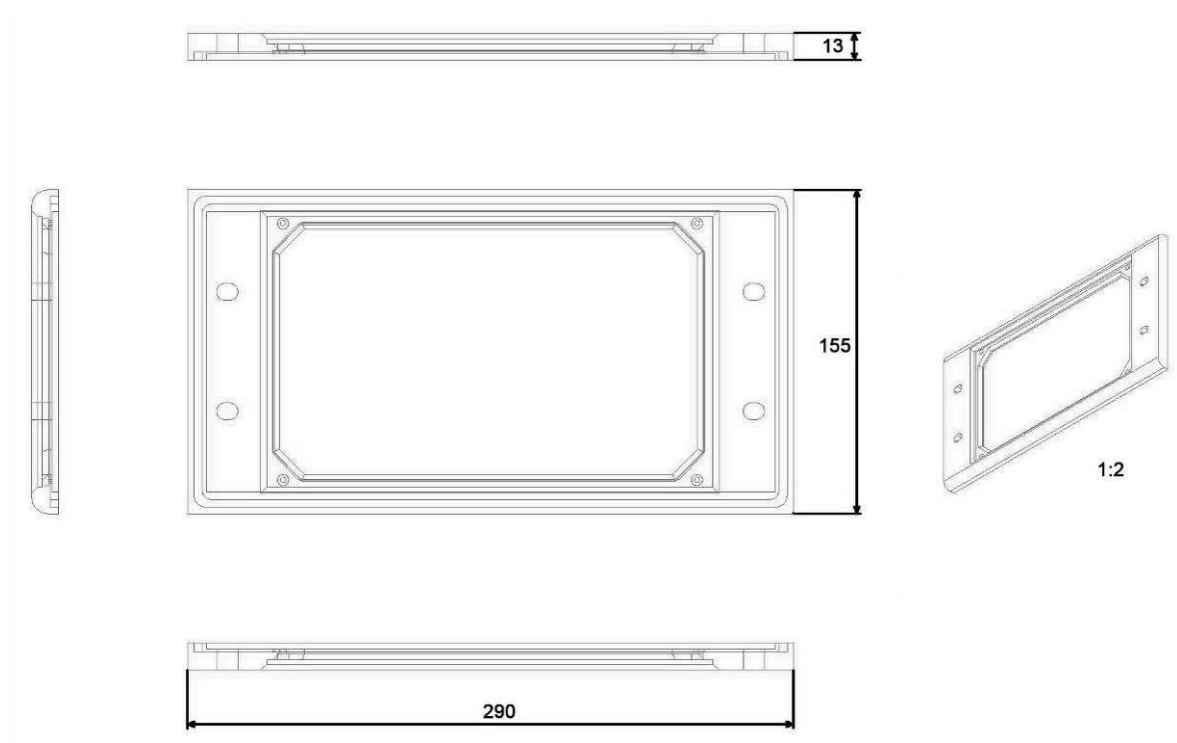

Figure 21-22 42 HP IP frame dimensions

1.3.23.7. Fold-down mounting

1.3.23.7.1. Fold-down mounting without terminals

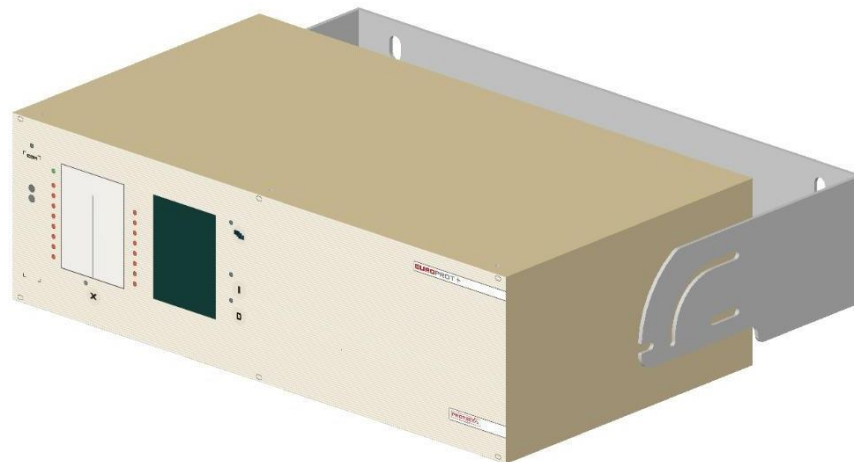
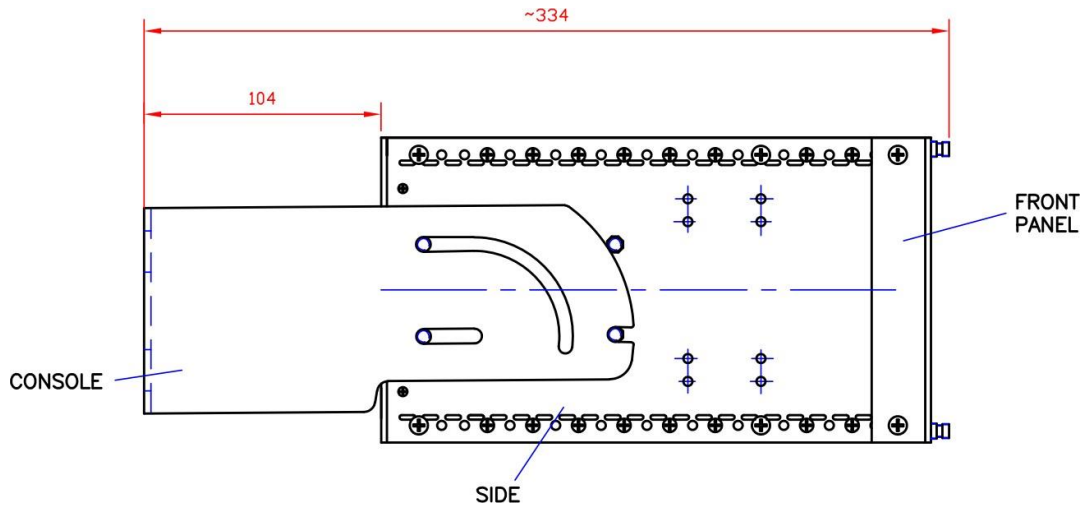
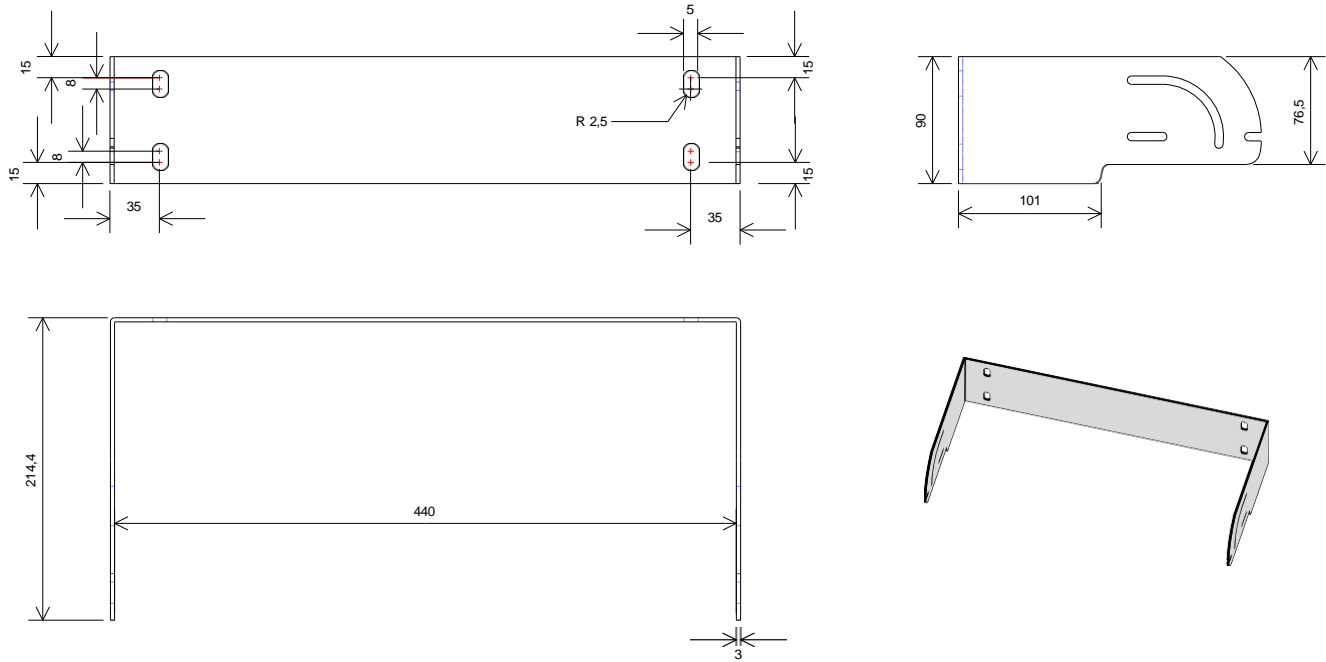

Figure 21-23 84 HP fold-down mounting

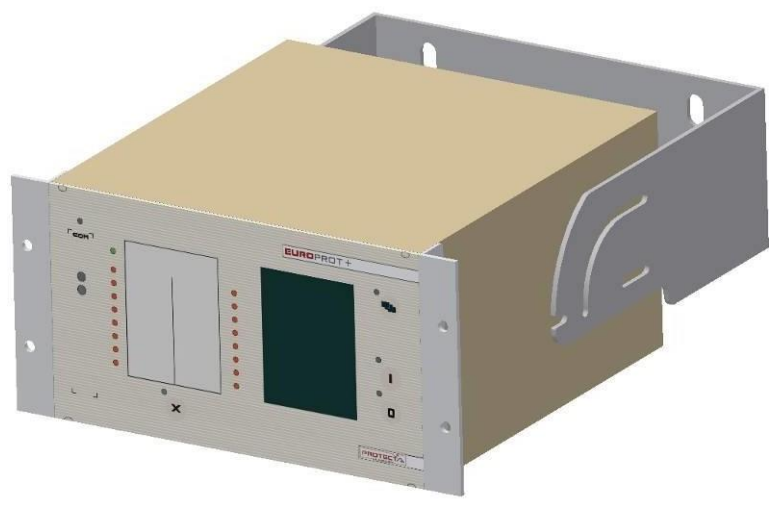
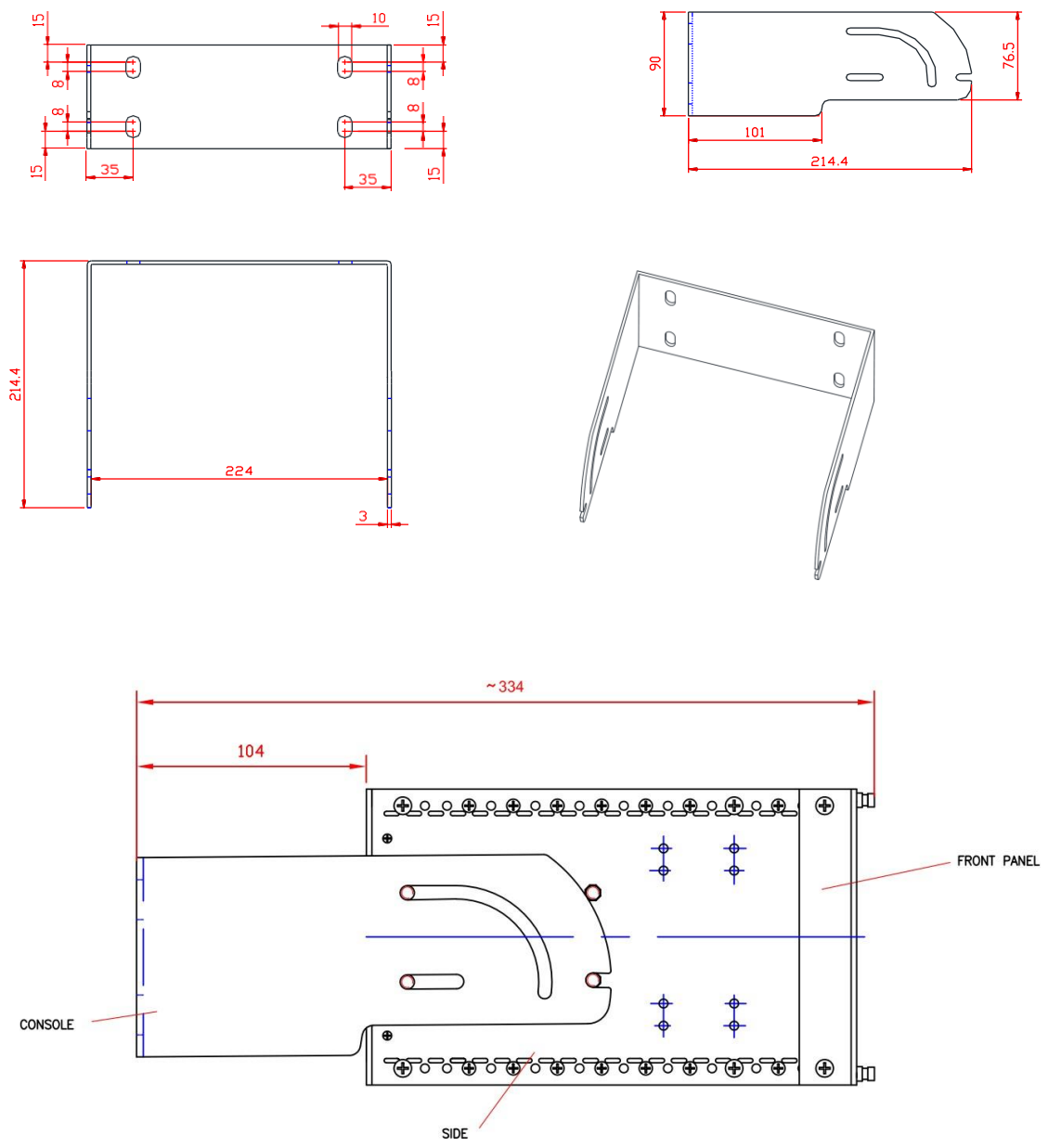

Figure 21-24 42 HP fold-down mounting

1.3.23.7.2. Fold-down mounting with terminals

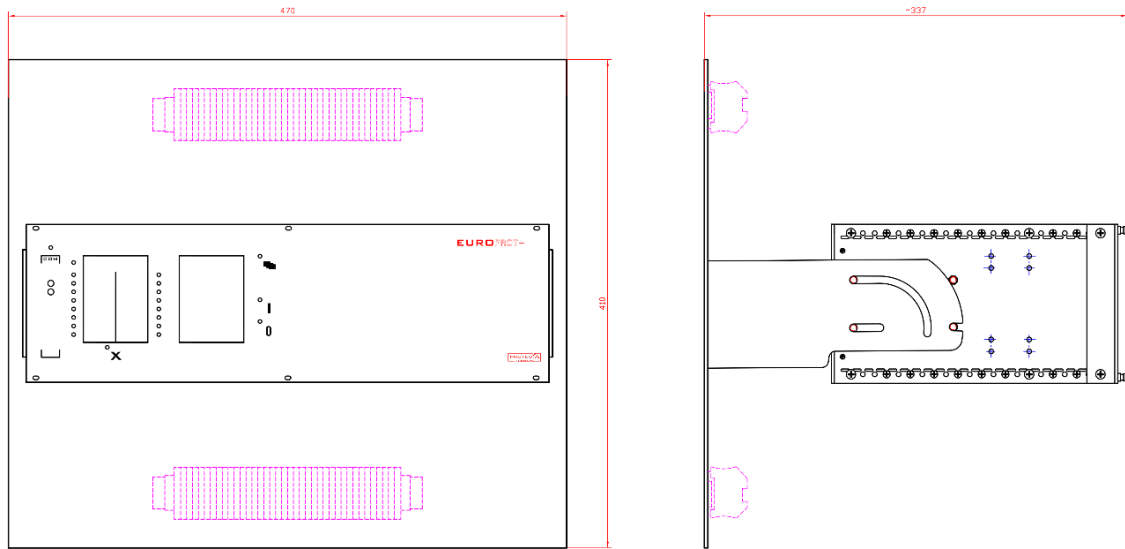

Figure 21-25 Fold-down mounting with terminals for 84HP devices

*fastening points are customized

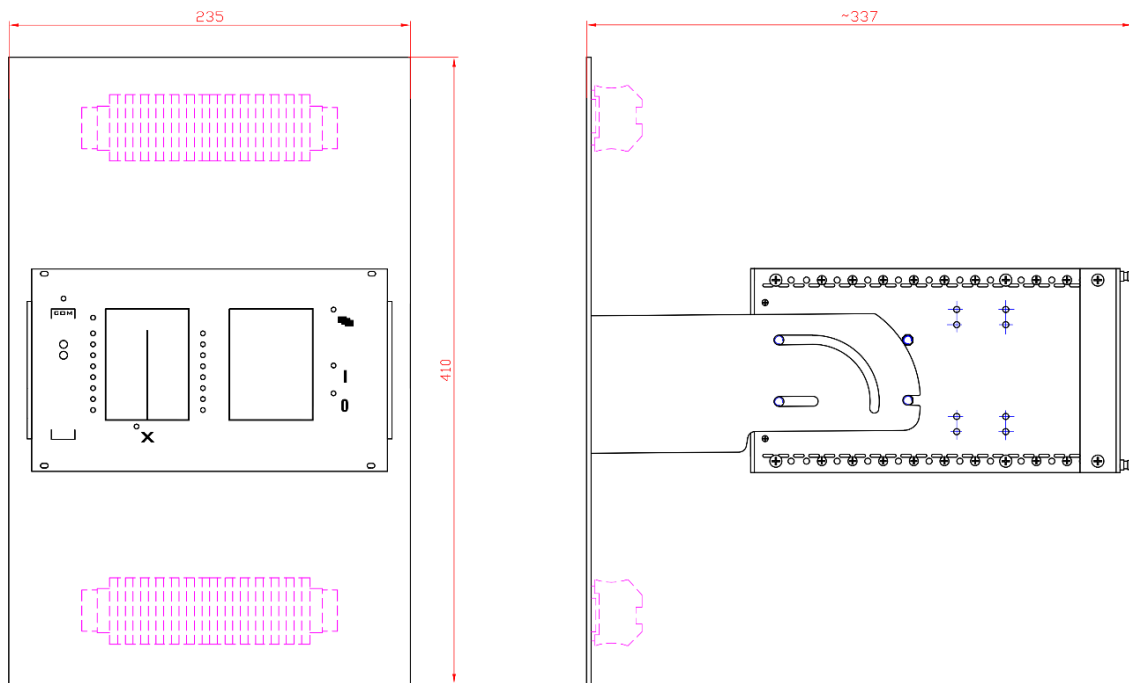
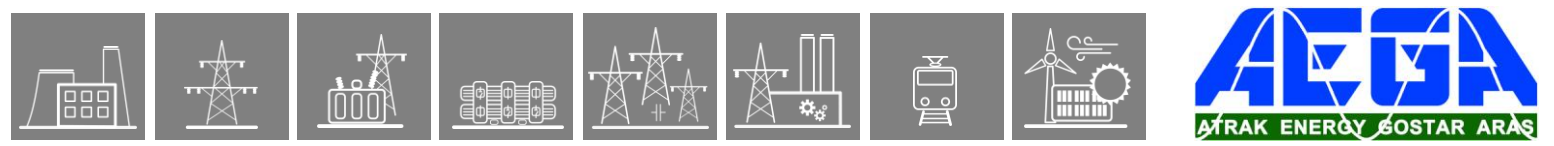

Figure 21-26 Fold-down mounting with terminals for 42HP devices



1.3.23.8. No mounting

“No mounting” means that the 84 HP and 42 HP devices do not have any mounting accessories on them.

This mounting method is only applicable if the device is for demonstration application.

For more information about this topic please contact our Application Team.
(application@protecta.hu)

IMPORTANT
 The dimensions of the cut-outs applicable for the remote HMI are depending on which previously mentioned mounting method is used (flush mounting, semi-flush mounting or rack mounting).

1.3.23.9. Remote HMI devices

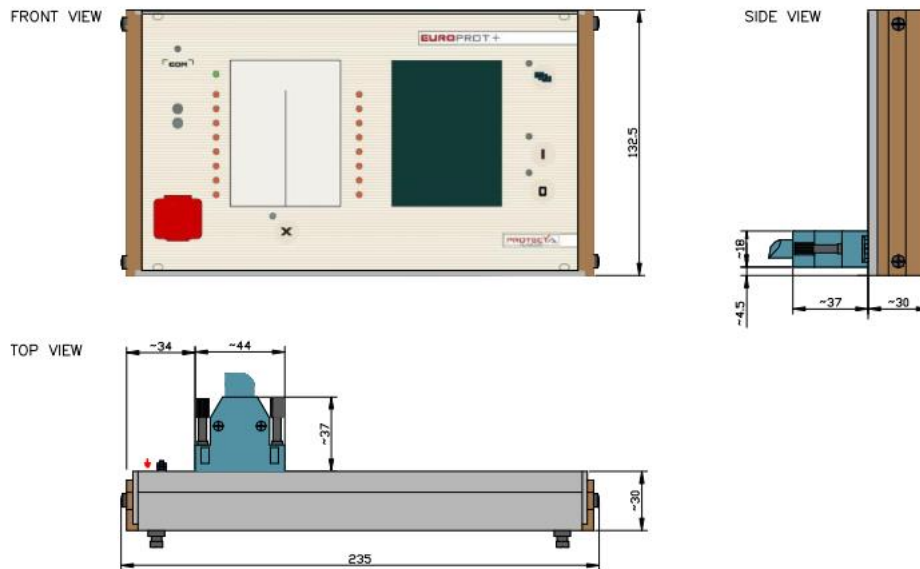

Figure 21-27 Dimensions for 42 HP wide remote HMI

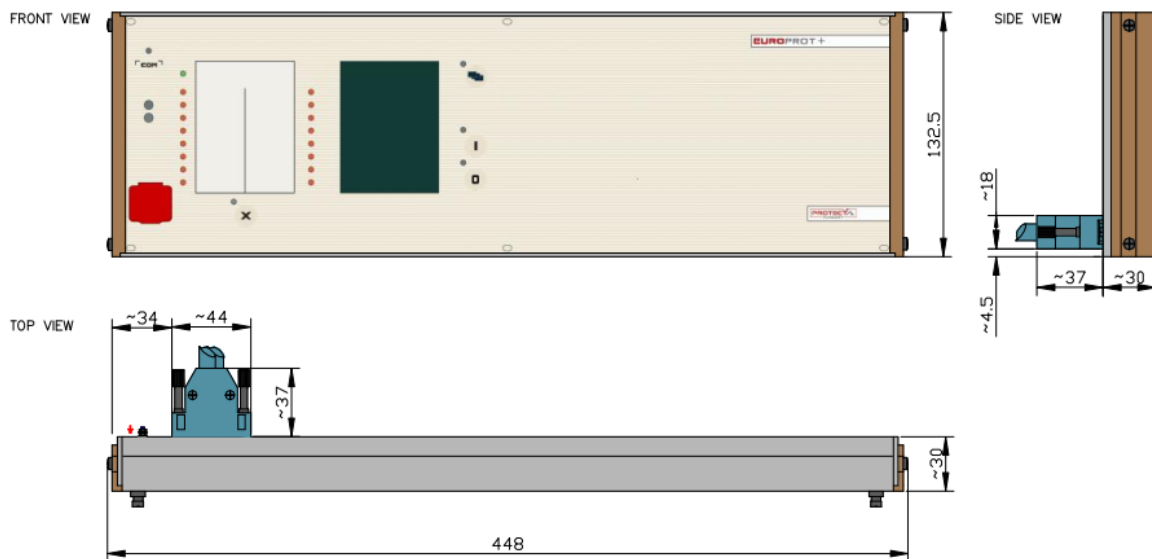
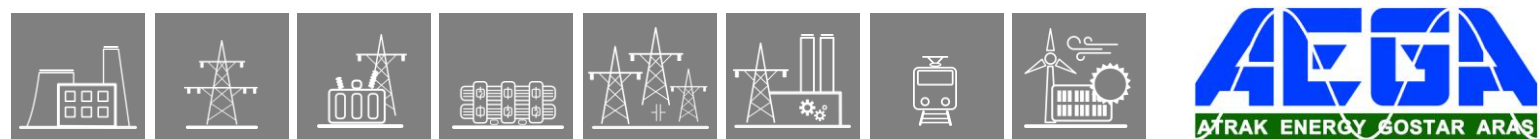

Figure 21-28 Dimensions for 84 HP wide remote HMI



1.3.24. Product availability (special and obsolete modules)

In this chapter you can read a list of the modules that have not regular availability for any reason (being obsolete or being used only in special configurations).

Special modules:

These modules can be ordered in case of special applications which are indicated for each module at its description in the previous chapters.

For more information about these devices please contact our Application Team. (application@protecta.hu)

Optional connectors:

The optional connectors are indicated at each module's description in the previous chapters. If a module is to be shipped with an optional connector, the issue must be discussed during ordering.

MODULE TYPE	COMMENT	DATE
CPU+/0001	Legacy CPU card, not recommended for new configurations. Replacement: CPU+1211	2013-06-12
CPU+/0002	Legacy CPU card, not recommended for new configurations. Replacement: CPU+1111	2013-06-12
CPU+/0003	Legacy CPU card, not recommended for new configurations. Replacement: CPU+1101	2013-06-12
CPU+/0004	Legacy CPU card, not recommended for new configurations. Replacement: CPU+1201	2013-06-12
CPU+/0005	Legacy CPU card, not recommended for new configurations. Replacement: CPU+1281	2013-06-12
CPU+/0006	Legacy CPU card, not recommended for new configurations. Replacement: CPU+1381	2013-06-12
CT+/1155	Available only for special configurations.	2013-06-12
CT+/5152	Available only for OGYD bay unit configurations.	2013-06-12
VT+/2215	Available only for special configurations.	2013-06-12
O12+/2101	Available only for demonstration applications.	2013-06-12
O12+/4201	Available only for demonstration applications.	2013-06-12
R4S+/01	Available only for special configurations.	2013-06-12
R4S+/16	Available only for special configurations.	2013-06-12
TRIP+/1101	Obsolete module. Not recommended for new designs.	2013-06-12
PS+/1602	Available only for special configurations.	2013-06-12
HMI+/2401	Obsolete module. Not recommended for new designs.	2014-10-06

HMI+/2404	Smart Line S24 special selection modules.	2014-10-06
HMI+/2504	Smart Line S24 special selection modules.	2014-10-06
COM+/8882	Available only for special configurations.	2014-10-06
CT+/1111	Available only for special configurations.	2014-10-06
CT+/2500	Available only for special configurations.	2014-10-06
CT+/5153	Available only for special configurations.	2014-10-06
VT+/2212	Available only for special configurations.	2014-10-06
R8+/01	Available only for special configurations.	2014-10-06
R8+/A1	Available only for special configurations.	2014-10-06
R8+/C0	Available only for special configurations.	2014-10-06
R8+/FF	Available only for special configurations.	2014-10-06
R12+/4400	Available only for special configurations.	2014-10-06
R16+/0101	Available only for special configurations.	2014-10-06
R16+/0001	Available only for special configurations.	2014-10-06
R16+/A001	Available only for special configurations.	2014-10-06
PS+/4401	Available only for special configurations.	2014-10-06
CT+/2500	Obsolete module. Not recommended for new designs. Replacement: CT+1500.	2015-02-13
PSTP+/2102	Available only for special configurations.	2015-06-23
PSTP+/4202	Available only for special configurations.	2015-06-23
CT+/5111	Available only for special configurations.	2015-12-08
CT+/0101	Available only for special configurations. DEFL earth fault protection only.	2018-03-19
INJ+/0015	Available only for special configurations.	2018-03-19
CT+/5155	Available only for special configurations.	2018-03-26
VT+/2246	Available only for special configurations.	2018-03-26
AIC+/0201	Obsolete module. Not recommended for new designs.	2018-03-26
CT+/5111	Obsolete module. Not recommended for new designs.	2018-03-27
VS+/0031	Obsolete module. Not recommended for new designs.	2018-05-25

R1T+/0001	Available only for special configurations. DMD.	2018-10-05
CT+/5253	Available only for special configurations.	2018-10-05
42 HP housing	The length of the 42 HP box has been reduced from 242 mm to 223 mm. For more information about the previous size of the 42 HP box please see the Figure 22-1.	2018-12-18
AIC+/0200	Obsolete module. Not recommended for new designs.	2019-04-08
PS+/1030	Available only for special configurations.	2020-05-07
PS+/1060	Available only for special configurations.	2020-05-07
HMI+/5001	Obsolete module. Not recommended for new designs.	2020-06-04
HMI+/5002	Obsolete module. Not recommended for new designs.	2020-06-04
HMI+/3502 (for 42HP)	Obsolete module. Not recommended for new designs.	2020-06-04
CT+/1515	Available only for special configurations.	2020-06-04
CT+/5115	Available only for special configurations.	2020-06-04
CT+/5116	Available only for special configurations.	2020-06-04
CT+/5154	Available only for special configurations.	2020-06-04
PSF+/1001	Available only for special configurations.	2020-06-04
RTD+/0200	Available only for special configurations.	2020-06-04
RTD+/1200	Available only for special configurations.	2020-06-04
R4MC+/01	Available only for special configurations.	2020-06-04
PS+/4301	Obsolete module. Not recommended for new designs.	2020-06-04
84 HP housing	The depth of the 84 HP box has been reduced from 242 mm to 223 mm. For more information about the previous size of the 84 HP box, see the Figure 22-1.	2021-04-01
HMI+/3501	Obsolete module. Not recommended for new designs.	2021-04-20
HMI+/3502	Obsolete module. Not recommended for new designs.	2021-04-20
HMI+/5701	Obsolete module. Not recommended for new designs.	2021-04-20
HMI+/5702	Obsolete module. Not recommended for new designs.	2021-04-20
COM+/1202	Obsolete module. Not recommended for new designs.	2021-04-20
COM+/1324	Obsolete module. Not recommended for new designs.	2021-04-29
VT+/2212	Obsolete module. Not recommended for new designs.	2021-05-06
CT+/5154	Obsolete module. Not recommended for new designs.	2021-05-06
O16+/2401	Obsolete module. Not recommended for new designs.	2022-03-22
O16+/4801	Obsolete module. Not recommended for new designs.	2022-03-22

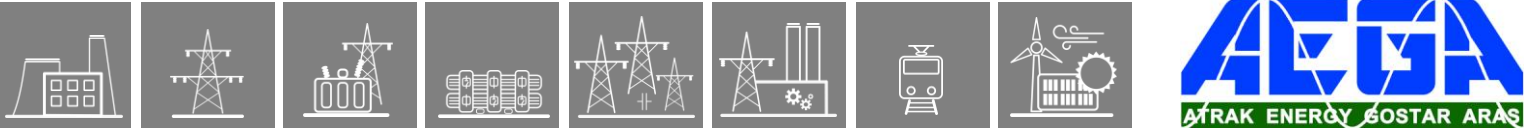

O16+/1101	Obsolete module. Not recommended for new designs.	2022-03-22
O16+/2201	Obsolete module. Not recommended for new designs.	2022-03-22

1.3.24.1. Previous 42HP and 84HP device housings

As of 2021. Q2, not only the 42HP, but the 84HP devices are shipped with shorter racks as well. Note that this is the only difference between the new and old housings. The new racks are shorter by 19 mm from the front, thus their depth is 223 mm instead of 242 mm.

The mounting methods described in Chapter 21 are valid for the previous racks as well, keeping in mind that the depth of the device is 19 mm bigger than that of the drawings. As an example, see the previous drawing of the flush mounting for 42HP and 84HP devices in Figure 22-1. As a comparison, the new, shorter rack is also drawn in light blue.

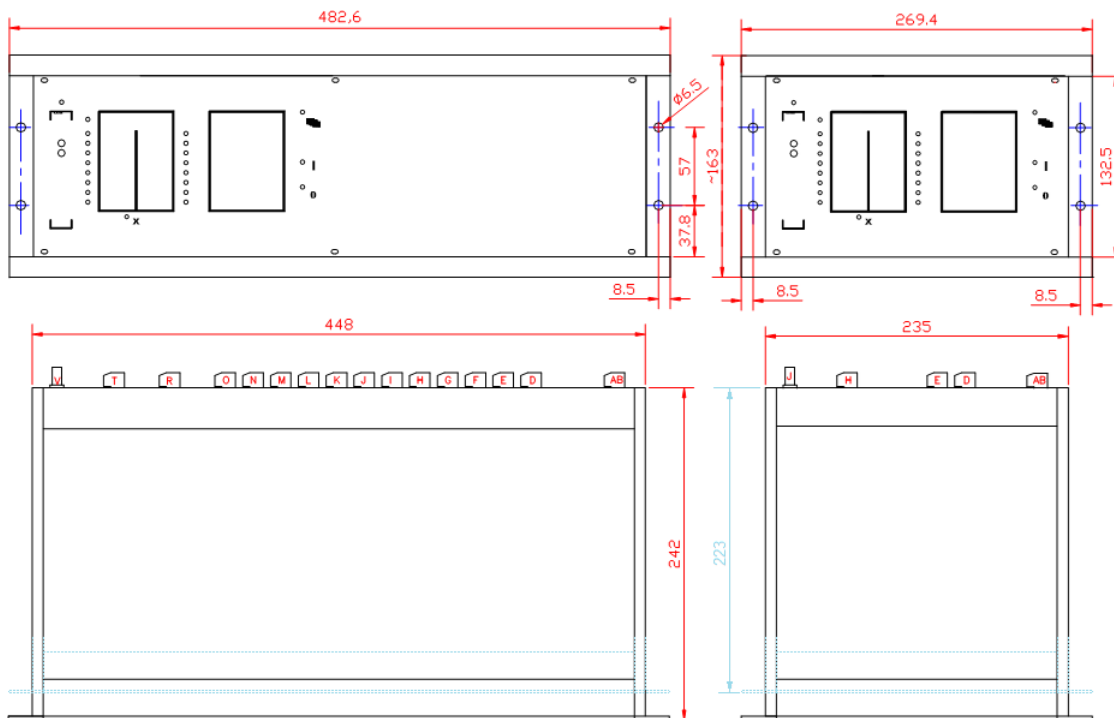

Figure 22-1 Dimensions for flush mounting of the previous 84HP and 42HP single rack, including the new (shorter) rack dimensions as well.

1.3.25. Remote I/O (RIO) server description

1.3.25.1. Introduction

Remote I/O (RIO) server is an IED, which provides remote binary inputs and outputs far from an EuroProt+ protection device.



Figure 1-1 Remote I/O device



Figure 1-2 Front view and rear view with fastening for mounting rail

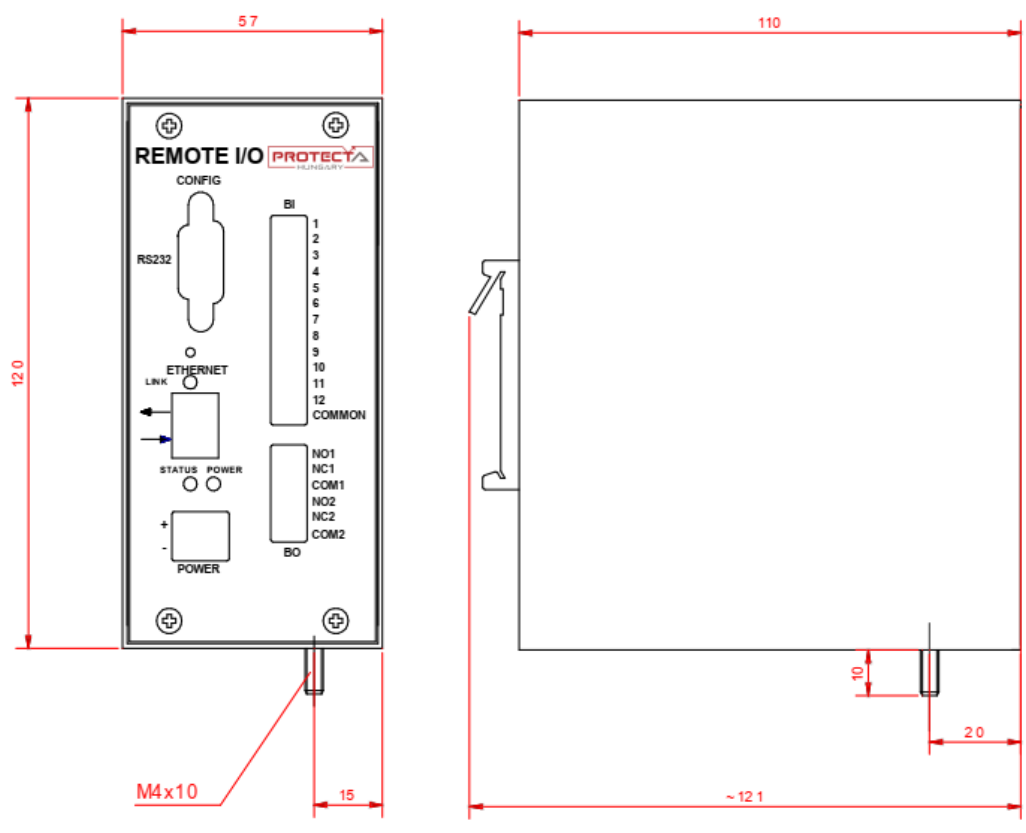

Figure 1-3 Remote I/O dimensions

1.3.25.2. Application

1.3.25.2.1. Connectors, LEDs

The connectors of the device are illustrated in the following figure.

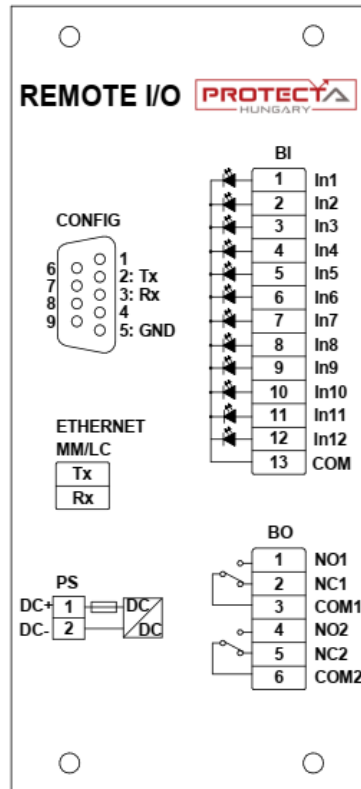

Figure 2-1 Connectors of the device

The RIO server has three LED indicators:

- **LINK:** located at the Ethernet connector; it shows active communication (green color)
- **POWER:** located above the power connector; it lights up if the device is operating (green color)
- **STATUS:** located also above the power connector. The behavior and color of this LED shows different situations:
 - Blinking **red**: there are no clients connected
 - Blinking alternatively **red-green**: the server has one client connected
 - Blinking **green**: two or more clients are connected

1.3.25.2.2. Wiring, usage

The device communicates with the EP+ device using the MODBUS/TCP protocol, via either of the COM+/1202, COM+/1324, COM+/1335, COM+/6603 or COM+/6663 modules.

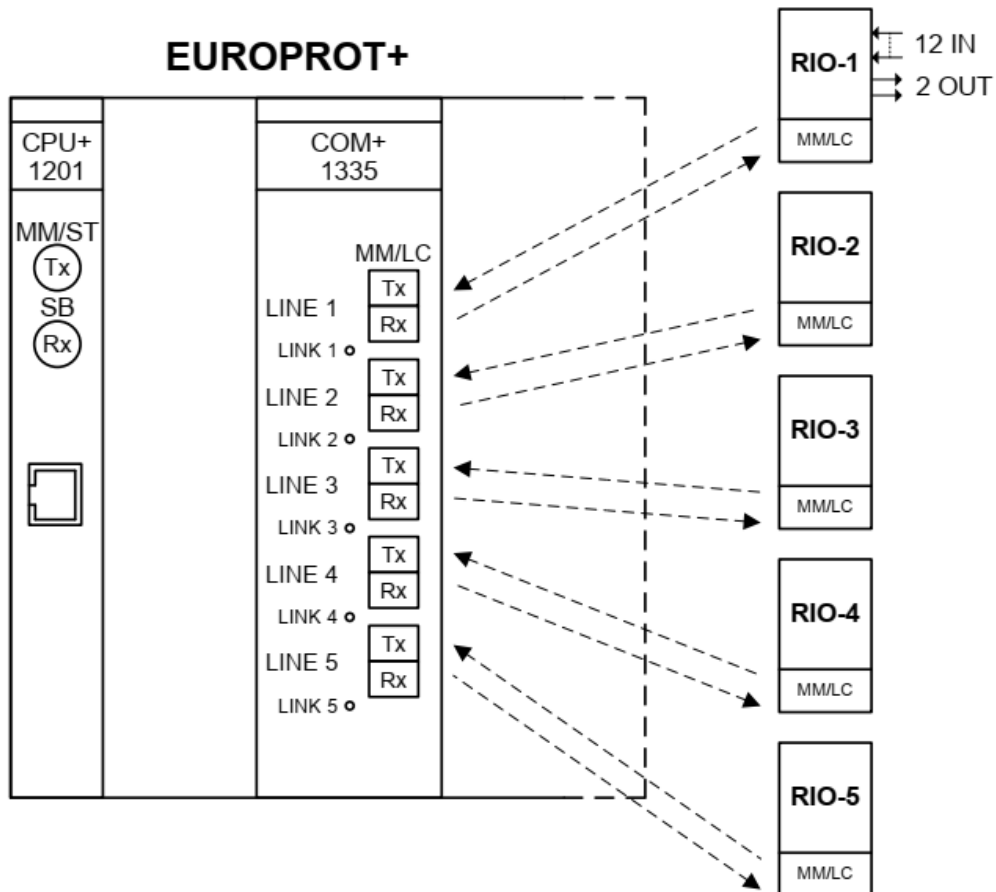

Figure 2-2 Wiring of the Remote I/O-s

The RIO inputs and outputs appear among the other binary inputs and outputs of the EuroProt+ device, and they can be utilized the same way.

1.3.25.3. Sub-modules

The RIO server consists of two mixed function modules:

- SCPU/PS: combination of a CPU and power supply module
- SO12/R2: binary I/O module with 12 inputs and 2 relay outputs

1.3.25.3.1. SCPU/PS sub-module

The SCPU/PS module contains all the control, communication and the power supply functions of the device.

1.3.25.3.1.1. CPU

Table 3-1 Technical data of the RIO CPU

CPU TYPE	ETHERNET INTERFACE	SERVICE PORT
SCPU+0011	MM/LC 1300 nm, 50/62,5/125 µm connector, 100Base-FX	RS232*

*The service port labeled "CONFIG" is only for factory usage

1.3.25.3.1.2. Power supply, external MCB

Table 3-2 Technical data of the RIO power supply

PS TYPE	INPUT VOLTAGE	NOMINAL POWER	INPUT VOLTAGE INTERRUPTION TIME	INRUSH CURRENT (< 0.1 s)	CONNECTOR TYPE
PS+1101	65-180 V DC	9 W	min. 140 ms @ 110 V DC input voltage	< 10 A	Weidmüller BLA 2/180
PS+2301	176 – 264 V DC 160 – 250 V AC	9 W	min. 50 ms @ 230 V AC input voltage	< 10 A	Weidmüller BLA 2/180

The power supply must be protected by an **external midjet circuit breaker**. Note that it is not part of the RIO device:

- Characteristics: **6A C**

1.3.25.3.2. SO12/R2 sub-module

The SO12/R2 module contains 12 binary inputs in one grounding group, and 2 relay outputs with dry contacts.

1.3.25.3.2.1. Binary inputs

Main features:

- Digitally filtered per channel
- Current drain approx.: 2 mA per channel

Table 3-3 Technical data of the binary inputs

BI TYPE	CHANNEL NUMBER	TIME SYNC.	RATED VOLTAGE	THERMAL WITHSTAND VOLTAGE	CLAMP VOLTAGE	CONNECTOR TYPE
SO12+4801	12	-	48 V	72 V	falling 0.71 U _N rising 0.76 U _N	Weidmüller BL 3.5/13/180
SO12+1101	12	-	110 V	250 V	falling 0.7 U _N rising 0.73 U _N	Weidmüller BL 3.5/13/180

Thermal withstand voltage: continuous with 60 % of the input channels energized.

1.3.25.3.2.2. Binary outputs

Main features:

- Breaking capacity, (L/R = 40 ms) at 220 V DC: 0.2 A
- Breaking capacity, (L/R = 40 ms) at 110 V DC: 0.3 A

Table 3-4 Technical data of the relay outputs

BO TYPE	RATED VOLTAGE	CONTINUOUS CARRY	CONTACT VERSIONS	GROUP ISOLATION	CONNECTOR TYPE
R2+0001	250 V AC/DC	6 A	CO	2 independent	Weidmüller BL 3.5/6/180



1.3.25.4. General data

- Storage temperature: - 40 °C ... + 70 °C
- Operation temperature: - 20 °C ... + 55 °C
- Humidity: 10 % ... 93 %
- Altitude: up to 2000 m
- Atmospheric pressure: 86 ... 106 kPa

1.3.25.4.1. Standard conformance

- Electrostatic discharge immunity (ESD), IEC-EN 60255-26:2013, Level 4
 - Test voltages: 15 kV air discharge, 8 kV contact discharge
- Radiated, radio-frequency, electromagnetic field immunity, IEC-EN 60255-26:2013 Level 3
 - Test field strength: 10 V/m
- Electrical fast transient/burst immunity (EFT/B), IEC-EN 60255-26:2013, Level 4
 - Test voltage: 4 kV
- Surge immunity test, IEC-EN 60255-26:2013
 - Test voltages: 2 kV line-to-earth, 1 kV line-to-line
- Immunity to conducted disturbances, induced by radio-frequency fields, IEC-EN 60255-26:2013, Level 3
 - Test voltage: 10 V
- Damped oscillatory wave immunity test, IEC-EN 60255-26:2013
 - Test frequency: 1 MHz
 - Test voltage: 2.5 kV in common mode, 1 kV in differential mode
- Voltage dips, short interruptions and voltage variations immunity, IEC-EN 60255-26:2013
 - Voltage dips: 40 % (200 ms), 70 % (500 ms), 80 % (5000 ms)
- Ripple on d.c. input power port immunity, IEC-EN 60255-26:2013
 - Level 4, 15 % of rated d.c. value
- Power frequency magnetic field immunity test, IEC-EN 60255-26:2013, Level 5
 - Test field strength: 100 A/m continuous, 1000 A/m for 3 s
- Power frequency immunity test on the binary inputs, IEC-EN 60255-26:2013, Class A
 - Test voltages: 300 V in common mode, 150 V in differential mode
- Insulation tests, IEC-EN 60255-27:2013
 - Impulse voltage test
 - Test levels: 5 kV (1 kV for transducer and temperature measuring inputs)
 - Dielectric test
 - Test levels: 2 kV AC 50 Hz (0.705 kV DC for transducer inputs)
 - Insulation resistance
 - Insulation resistance > 15 GΩ
- Radiated emission, IEC-EN 60255-26:2013

Limits:

 - 30 MHz to 230 MHz: 50 dB(μV/m) quasi peak, 3 m
 - 230 MHz to 1 000 MHz: 57 dB(μV/m) quasi peak, 3 m
 - 1 GHz to 3 GHz: 76 dB(μV/m) peak, 3 m
 - 3 GHz to 6 GHz: 80 dB(μV/m) peak, 3 m
- Conducted emission, IEC-EN 60255-26:2013

Limits:

 - 0,15 MHz to 0,50 MHz: 79 dB(μV) quasi peak, 66 dB(μV) average
 - 0,5 MHz - 30 MHz: 73 dB(μV) quasi peak, 60 dB(μV) average
- Vibration, shock, bump and seismic tests on measuring relays and protection equipment
 - Vibration tests (sinusoidal), Class I, IEC 60255-21-1:1988
 - Shock and bump tests, Class I, IEC 60255-21-2:1988
 - Seismic tests, Class I, IEC 60255-21-3:1993

1.3.25.5. Mechanical data

1.3.25.5.1. General mechanical data

- Construction
 - Painted steel surface
- IP protection:
 - IP2x
- Size:
 - See Figure 1-3 for the device dimensions
- Weight:
 - 0.7 kg

1.3.25.5.2. Connectors

Table 5-1 Connectors on the RIO

CONNECTOR NAME	CONNECTOR TYPE	STRIP LENGTH [MM]	CONDUCTOR AREA [MM ²]	CONDUCTOR DIAMETER [MM]	TIGHTENING TORQUE [Nm]	MINIMUM BEND RADIUS*
BLA	Weidmüller BLA 2/180	7	0.2 – 1.5 solid: 0.2 – 2.5	0.5 – 1.4 solid: 0.5 – 1.8	0.4 – 0.5	3 × OD**
BL 3.5	Weidmüller BL 3.5/6/180 BL 3.5/13/180	6	0.2 – 1.5	0.5 – 1.4	0.2 – 0.25	3 × OD**
PE FASTON TERMINAL	TE Connectivity 6.3x0.8	7	min. 4	min. 2.3	-	3 × OD**

* Bend radius is measured along the inside curve of the wire or wire bundles.

** OD is the outer diameter of the wire or cable, including insulation.

The tightening torque of the screw for protective earth connection must be approx. 5 Nm.

During the installation, make sure that the shortest possible length for PE (Protective Earth) cable.

The minimum distance between the device and its wire channel must be at least 3 cm.

1.3.26. Technical notes on EOB interoperability

1.3.26.1. Description

We experienced some interoperability issues regarding front panel communication with EP+ devices. The link establishment procedure of the ethernet communication become unstable with certain type of NICs (Network Interface Card) of network devices. Network devices with 10/100Base-T speed support has no limitation but devices with 1000Base-T (called gigabit) may cause this link establishment failure. In this case the operating system periodically signals that interface is connected, then disconnected, then connected etc.

1.3.26.2. EOB Troubleshooting

- force NIC speed and mode to 10Base-T Full-duplex (setting method may depend on Your PC hardware configuration) on Your PC. Local Area Network settings can be found at:
 - WindowsXP: Control Panel/Network Connections/Local Area Connection
 - Windows 7: Control Panel\All Control Panel Items\Network and Sharing Center

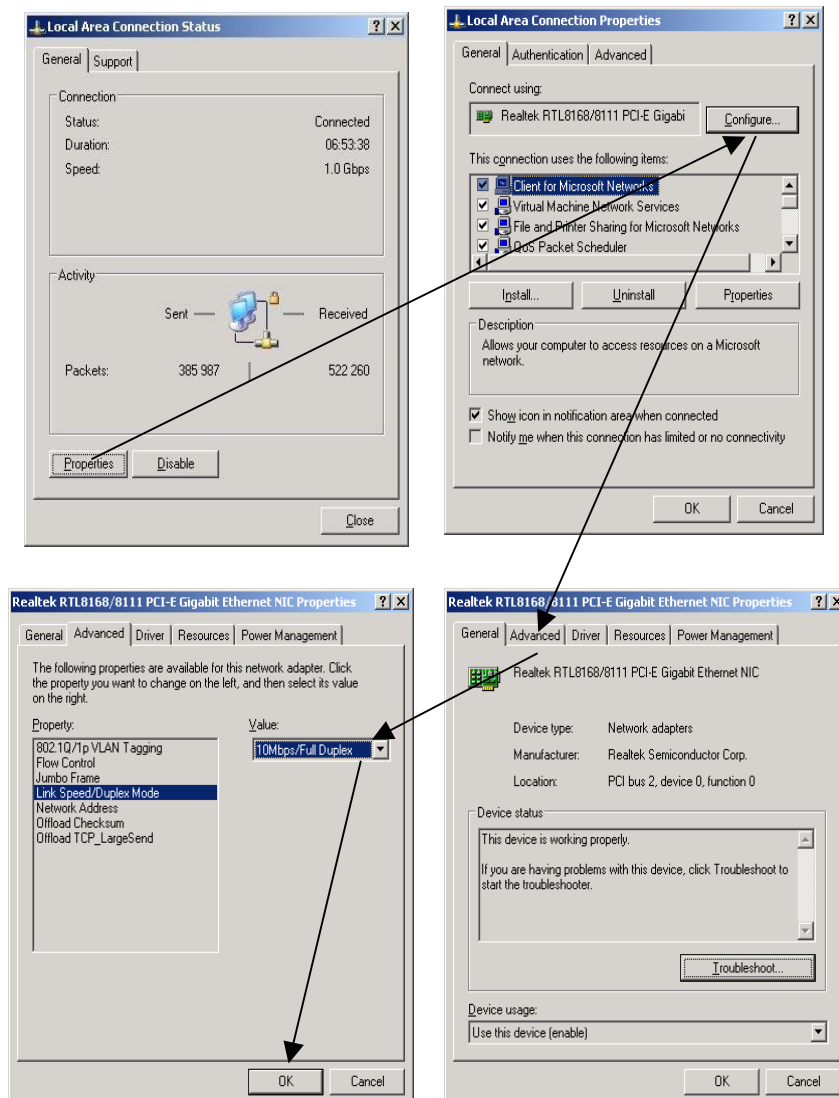

1.3.26.3. Workaround

- using station bus interface connector at the front panel of the CPU card
- if the device equipped with 100Base-Fx station bus interface then You can connect Your computer via a third-party media converter unit
- if the device equipped with 10/100Base-Tx station bus interface (RJ45) then connect Your computer directly to the EP+ via a crossed CATx cable

Service computer

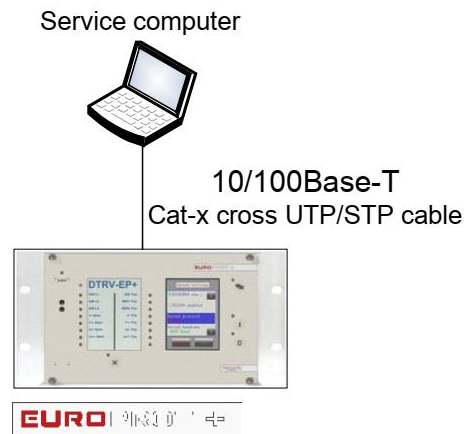

- using EOB at the HMI:
 - in case of unstable link with Your PC apply a third-party external 10/100Base-T switch with one port connected via EOB to the EP+ and other port connected to Your PC via a CATx cable.

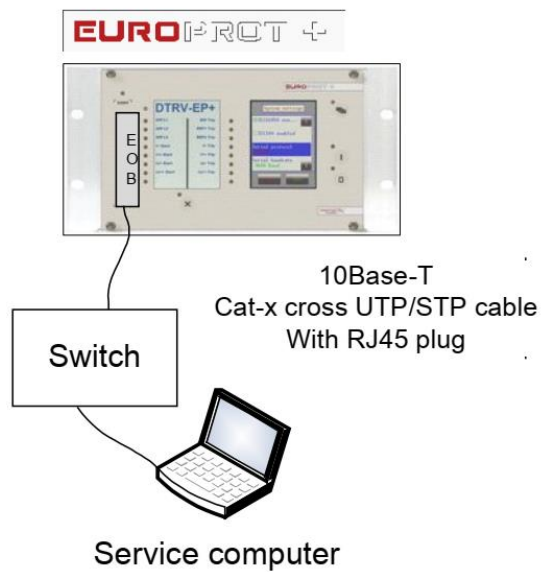

1.3.26.4. Further details

For getting started guide and IP configuration download: <http://www.protecta.hu/epp-prelim/QuickStart/Quick Start Guide V1.0.pdf>

1.3.27. EP+ Installation manual

USED SYMBOLS

Symbols on devices:



Test voltage: 2 kV



Protective conductor terminal



Do not dispose of this device

Symbols in this document:



Caution, risk of electric shock



Caution, hot surface



Caution, refer to the documentation



Do not dispose of this device



1.3.27.1. Introduction

This manual is intended to provide instruction for proper device installation, which includes mechanical mounting and electrical wiring. Furthermore, the information provided here will strongly support commissioning, maintenance, and deinstallation work as well. This document's targeted user groups are skilled electrical professionals executing installation works and commissioning with EuroProt+ devices.

Given that the EuroProt+ product family has a modular design, the instructions provided here can cover all configurations. Therefore, this manual shall be used in conjunction with the "EuroProt+ Hardware description" document, which includes essential information about all hardware components of the product.

1.3.27.2. Equipment handling

1.3.27.2.1. Unpacking

Inspect the package for transport damages. Carefully remove the packing material without applying excessive force.

1.3.27.2.2. Visual inspection

Identify the product by reading the order code. This can be found on the device nameplate located mostly on the right side of the device in the top right corner and shall be identical to your order.

Picture 2-2 Device nameplate



The protection device may have loose items packed in a different box based on the configuration. Check, that these items are also included in the shipment.

Visually inspect all unpacked items for damages, water ingress, or any sign of external impact. If you discover any transport damage, please notify Protecta Ltd. first and do not start any further work on the equipment.

1.3.27.2.3. Storage

If temporary storage is required before installation, please store the device in its original packing in a dry and clean place. The required environmental conditions can be found in the “General data” section of the “EuroProt+ Hardware description” document.

1.3.27.3. Mounting

1.3.27.3.1. Tools for mounting

The tools and screws necessary for mounting depend on the method of the mounting, see the “Mounting methods” section of the “EuroProt+ Hardware description” document.

Assuming the panel or cubicle is ready for installation of the device, screwdrivers matching the screws used, pliers, wrenches, etc. are necessary. For safety aspects, mechanical protective gloves shall be used to avoid injuries.

1.3.27.3.2. Environmental conditions

Make sure, that the mounting location fulfils environment requirements stated in the “General data” section of the “EuroProt+ Hardware description” document. The IP protection class of the device shall fit the surrounding environment at the place of installation. It is also important to have space around the device to support conventional cooling (See 3.3).

1.3.27.3.3. Mounting location

Before mounting the device make sure, that suitable space is available in the location of installation. Cutouts shall fit the device rack dimensions and it is recommended to leave 80mm free space behind the IED for the wiring.

The minimum distance between an EP+ device and its wire channel must be at least 3 cm. The minimum distance between two EP+ devices must be at least 10 cm.

1.3.27.3.4. Mounting the device

The EuroProt+ product line utilizes different rack sizes and depending on that different mounting methods. An overview of the rack sizes with dimensions and mounting methods can be found in the “Mounting methods” section of the “EuroProt+ Hardware description” document.

During the installation make sure that the shortest possible length for PE (Protective Earth) cable routing is applied.

1.3.27.3.5. Safety aspects

1.3.27.3.5.1. Earth connections

1.3.27.3.5.1.1. Protective earth

The device shall be connected to the station earth system with a minimum of 2,5 mm² cross-section solid or stranded wire. A 6,3 mm (1/4 inch) female flat connector (according to IEC 61210) shall be used crimped to the earthing wire. During the installation make sure that the shortest possible length for PE (Protective Earth) cable routing is applied.

The earth connection of the device is situated at all kinds of Power supply modules. In the case of more Power supply modules, all of them shall be earthed.

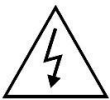

The protective earth connections should not be removed when the equipment is energized.

Picture 3-5-1-1 Earth connection point of the device at the Power supply module



1.3.27.3.5.1.2. Stranded wires

Soft soldering of stranded wires is not allowed due to the cold flow of the solder material.



Loose strands of stranded wires can cause fire risk or electric shock. Insulated crimp terminals shall be used.

1.3.27.3.5.1.3. Cable screen connection

The screen of the telecommunication cables connected directly to the device shall be terminated to the earthing connection point of the corresponding module.

Picture 3-5-1-3 An example of the cable screen connection

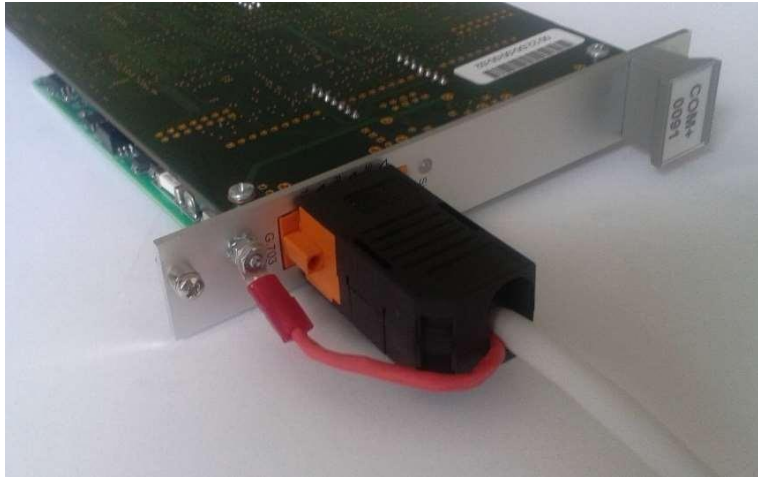

1.3.27.3.5.1.4. CT and VT circuits

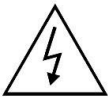

The CT and VT circuits to be connected to the device shall be connected to the station earth system.

1.3.27.3.5.2. Connections of the device

Before connecting the wires, make sure that all voltage levels correspond to the device ratings. It is particularly important by the power supply, trip and binary input, CT and VT module

Use only the connectors provided to the device or identical ones.

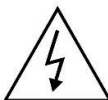

The CT connectors shall be fixed with screws provided. During the operation of the device, the CT connectors can be disconnected only after the CT circuits having short-circuited.

1.3.27.3.5.3. Optical ports



Take adequate measures to protect your eyes and do not view directly into optical ports.

The fiber optics cables are vulnerable. Sharp bending can damage them. The minimum bending radius can be between 15 cm and 25 cm approximately, depending on the type and the material of the cable. For details see the datasheets of the fiber optics cables to be installed. The fiber shall not be twisted or bent. When connecting or disconnecting the cable always hold the connector, not the cable.

1.3.27.3.5.4. Removing and changing modules

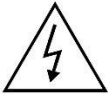

Before removing and changing modules first the power supply voltage of the device shall be disconnected. Then all the energizing quantities connected to each module of the device shall be disconnected. Before removing the connectors of the CT modules, the CT circuits shall be short-circuited and disconnected.

The protective earth connection can be disconnected last if it is necessary (e.g. when removing a Power supply module).



The devices contain components that are sensitive to electrostatic discharges. ESD wrist strap shall be worn during any operations with modules.



Some of the modules can operate at high internal temperatures. Remove these modules carefully to avoid any burn injury. Take care of the possible high temperature at each module.



The modules have got sharp edges. Remove them carefully to avoid injury.

After changing a module, it shall be fixed with the screws provided with a torque of 0,5 Nm. Use Philips 2 screwdriver.

1.3.27.4. Wiring

1.3.27.4.1. Tools for connecting

Screwdrivers for the connectors: blade 0,6/3,5 mm, 0,4/2,5 mm.

Cutter, stripper, crimper tools to prepare the connecting end of the wires.

1.3.27.4.2. Connectors

The “Connectors” section of the “EuroProt+ Hardware description” provides information about the required conductor dimensions and connecting methods. The “Connectors” table shall be used together with the other sections describing the different modules.

1.3.27.5. Deinstallation and Repair

1.3.27.5.1. Deinstallation



Before removing the device make sure, that all incoming power supply and control voltages are switched off. The earth connection of the device shall be disconnected last.

1.3.27.5.2. Repair



Thanks to its modular design, many hardware problems can be fixed by replacing single modules. By executing this procedure note, that the printed board’s surface may get hot during normal operation.



In addition, attention shall be paid to the sharp edges of the modules to avoid minor injuries on the hand.

1.3.27.5.3. Disposal



Removed IEDs shall be handed over to a local electronic waste handler for proper disposal and recycling.

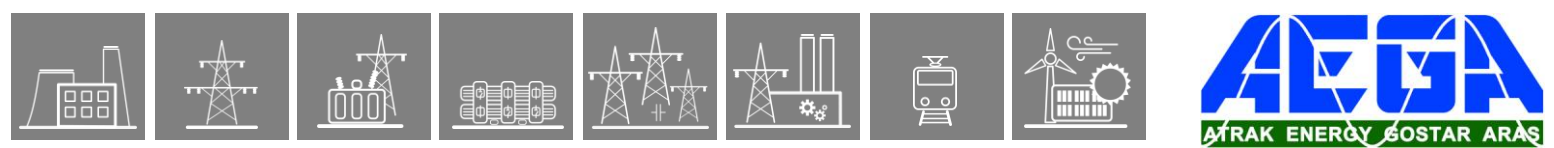
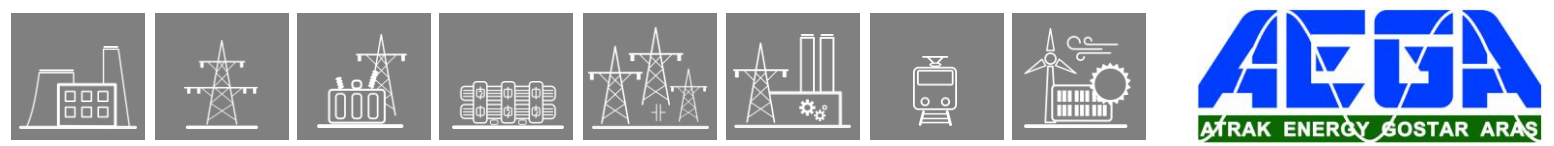

Table 5-3 Disposal of the components and parts

IED	PARTS	MATERIAL	METHOD OF DISPOSAL
Enclosure	Metal sheets, fastening elements	Aluminum, steel	Separation and recycling
Modules	Metallic parts, fastening elements	Aluminum, steel	Separation and recycling
	Mounted PC boards	Plastic, various electronic elements	Separation and recycling
	Connectors	Plastic, various metals	Separation and recycling
	Transformers, coils	Iron, copper, plastic, paper	Separation and recycling
	Relays	Iron, copper, plastic, other metals	Separation and recycling
Package	Box	Cardboard	Recycling
Attachments	Manuals, certificates	Paper	Recycling



2. Function and I/O listing

The functions listed in Table 2-1 on the next page are the ones that are present most commonly in the configurations, thus they can be considered as factory default arrangements. The hardware information corresponds to the maximum available number of digital I/O, and the default number of analog inputs.

*The 'INST.' column contains the numbers of the pre-configured function blocks in the factory configuration. These numbers may be different in order to meet the user's requirements.

Transmission line protection, control & automation							
					FAMILY		
					EuroProt+		
					DTVA		
HARDWARE	CONFIGURATION				E1	E2	
	CT inputs				4	4	
	VT inputs				4	4	
	Digital inputs (max)				128	128	
	Signaling relay outputs (max)				60	60	
	Fast Trip outputs (max)				12	12	
	FUNCTIONALITY	Function name		IEC	ANSI	*INST.	E1
Distance protection HV		Z <, FL	21	1	✓	✓	
Teleprotection			85	1	op.	✓	
Switch onto fault preparation function				1	✓	✓	
Synchrocheck		SYNC	25	1	✓	✓	
Definite time undervoltage protection		U <, U <<	27	2	✓	✓	
Directional overpower		P >	32	2	✓	✓	
Directional underpower		P <	37	2	✓	✓	
Negative sequence overcurrent protection		I2 >	46	1	✓	✓	
Negative sequence overvoltage protection		U2 >	47	2	✓	✓	
Thermal protection line		T >	49	1	✓	✓	
Three-phase instantaneous overcurrent protection		I >>>	50	1	✓	✓	
Residual instantaneous overcurrent protection		Io >>>	50N	1	✓	✓	
Breaker failure protection		CBFP	50BF	1	✓	✓	
Three-phase time overcurrent protection		I >, I >>	51	2	✓	Op.	
Residual time overcurrent protection		Io >, Io >>	51N	2	✓	Op.	
Definite time overvoltage protection		U >, U >>	59	2	✓	✓	
Residual overvoltage protection		Uo >, Uo >>	59N	2	✓	✓	
Three-phase directional overcurrent protection		I Dir >, I Dir >>	67	2	✓	✓	
Residual directional overcurrent protection		Io Dir >, Io Dir >>	67N	2	✓	✓	
Power swing detection		$\Delta Z/\Delta t$	68	1	✓	✓	
Inrush detection and blocking		I2h >	68	1	✓	✓	
Out-of-step/Pole slip		$\Delta Z/\Delta t$	78	1	✓	✓	
Auto-reclose HV		0 - > 1	79	1	✓	✓	
Overfrequency protection		f >, f >>	81O	2	✓	✓	
Underfrequency protection		f <, f <<	81U	2	✓	✓	
Rate of change of frequency protection		df/dt	81R	2	✓	✓	
Line differential		3IdL >	87L	1		✓	
Trip Logic			94	1	✓	✓	
Lockout Trip Logic			86	1	Op.	Op.	
Busbar sub-unit					Op.		
Bay control					✓	✓	
Circuit breaker wear					✓	✓	
Circuit breaker control					✓	✓	
Disconnecter control					✓	✓	
Ethernet Links					Op.	Op.	
Trip Circuit Supervision			74TC		✓	✓	
Fuse failure (VTS)			60	1	✓	✓	
Current unbalance protection			60	1	✓	✓	
Measuring					✓	✓	
Current input					✓	✓	
Voltage input					✓	✓	
Line measurement					✓	✓	

Table 2-1 Basic functionality and I/O

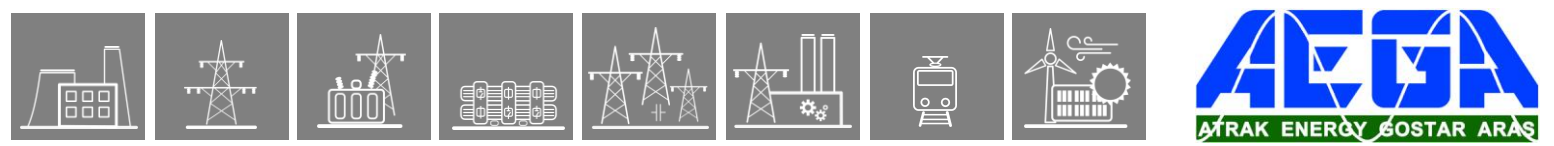

3. Line differential communication application guide

3.1. Introduction

This application guide is intended to explain different line differential protection communication methods with EuroProt+ devices.

Basically, the line differential protection is carried out either on 100Base-Fx fiber channel or on a serial HDLC-based channel. The communication protocol and the frame structure in Ethernet case is relies on the IEC61850-9-2LE specification but the required bandwidth is approximately 1.5Mbit/s and some proprietary frame fields were introduced. The data communication layer utilizes VLANs as identification.

3.1.1. Setting of the VLAN parameters

During user parametrization of the sending and receiving VLANs, VLAN priority and multicast address need to be set. The priority parameter matters only in case of telecom network with managed switches/routers are between the devices. Priority handling in the switch ensures time critical frames to be sent In time to its final destination. Direct fiber link application does not care about this parameter.

3.2. Peer-to-peer communication

3.2.1. Direct link

In case dark fiber is available between two substations, peer-to-peer communication mode is recommended with the following properties:

- Short-haul applications limited to 2km: multimode fiber,
- Short-haul application up to 27dB line attenuation (50km in practice): single mode fiber
- Long-haul applications up to 35dB line attenuation (100-120km in practice): single mode 1550nm fiber.

“COM1Dir: 1Dir. Communication module” (previously “CPUEth: CPU LDC module”) and “DIFF87L” functions must be in the configuration.

CPU labels are seen below are samples only. Other types of CPU modules can also be used.

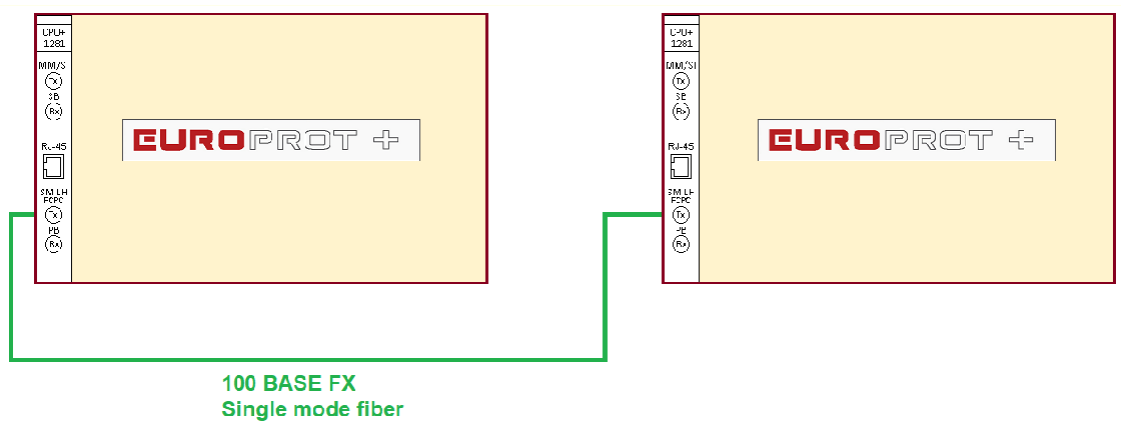

Figure 2-1 Schema of the Direct link communication

Table 2-1 Communication parameters of Direct link communication

COMMUNICATION PARAMETERS	COMMENT
Tx VLAN (1-4096)	Transmit VLAN ID Default values are: device 1:1 device 2:2
Rx VLAN	Receive VLAN ID Default values are: device 1:2 device 2:1
Priority (0-7)	VLAN priority (Default value is 4)
Multicast address (0 - 65535)	VLAN multicast address (Default value is 1)

3.2.2. Via LAN/Telecom network

“COM1Dir: 1Dir. Communication module” (previously “CPUeth: CPU LDC module”) and “DIFF87L” functions must be in the configuration.

CPU labels are seen below are samples only. Other types of CPU modules can also be used.

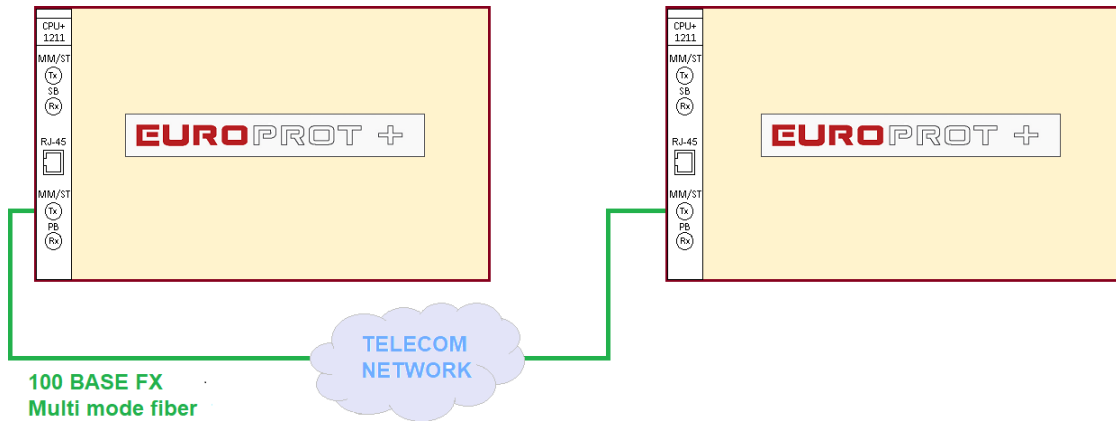

Figure 2-2 Schema of the communication via LAN/Telecom network

Table 2-2 Communication parameters of the communication via LAN/Telecom network

COMMUNICATION PARAMETERS	COMMENT
Tx VLAN (1-4096)	Transmit VLAN ID Default values are: device 1:1 device 2:2
Rx VLAN	Receive VLAN ID Default values are: device 1:2 device 2:1
Priority (0-7)	VLAN priority (Default value is 4)
Multicast address (0 - 65535)	VLAN multicast address (Default value is 1)

3.3. Pilot wire application

Pilot wire application allows protection devices to communicate with each other via traditional copper wire. The xDSL technology supports high speed and reliable communication channel establishment via 2-8 wire copper lines. The EuroProt+ is connected to an industrial grade Ethernet/SHDSL MODEM via an Ethernet 100Base-Fx interface.

“COM1Dir: 1Dir. Communication module” (previously “CPUeth: CPU LDC module”) and “DIFF87L” functions must be in the configuration.

CPU labels are seen below are samples only. Other types of CPU modules can also be used.

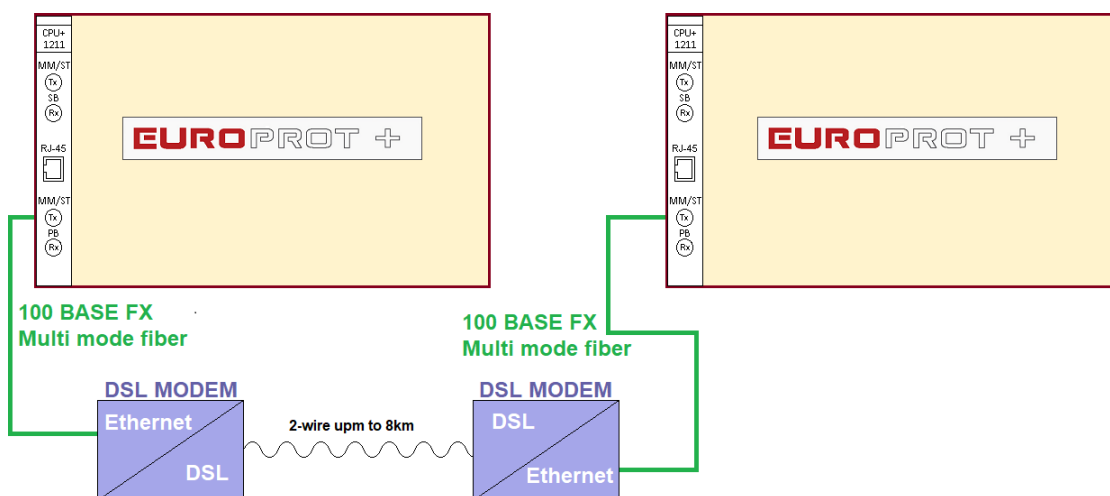

Figure 3-1 Schema of Pilot wire application

Table 3-1 Communication parameters of Pilot wire application

COMMUNICATION PARAMETERS	COMMENT
Tx VLAN (1-4096)	Transmit VLAN ID Default values are: device 1:1 device 2:2
Rx VLAN	Receive VLAN ID Default values are: device 1:2 device 2:1
Priority (0-7)	VLAN priority (Default value is 4)
Multicast address (0 - 65535)	VLAN multicast address (Default value is 1)

Table 3-2 SHDSL interface specification

Specification	ITU-T G.991.2-G.shdsl, ITU-T G.991.2-G.shdsl.bis
Line Code	TC-PAM16/32, Extended: TC-PAM4/8/64/128
Impedance	135Ω
Transmit Power	13.5 (Annex A) or 14.5 (Annex B) dBm @ 135Ω
Number of Pairs	1,2 or 4
Bit Rate	192 to 5704kbit/s, Extended: 128 to 15232kbit/s
Distance	Max. 8km @ 0.8mm (AWG-20) wire Max. 6km @ 0.6mm (AWG-23) wire Max. 4km @ 0.4mm (AWG-26) wire
Connector Type	RJ-45, 8 pin
Overvoltage Protection	ITU-T Rec. K.20/K.21
Wetting Current	2-4mA @ 47VDC

Table 3-3 Ethernet interface specification

Standard:	IEEE-802.3, VLAN IEEE-802.1Q, QoS IEEE-802.1P
Data Rate	100Base-TX, Full/Half Duplex
Interface/connector Type @ EuroProt+ side	Multi-mode 1310nm, ST connector
Interface/connector Type @ MODEM side	SFP multi-mode 1310nm, LC connector

3.4. Line differential communication via telecom networks

3.4.1. Communication via G.703 64kbit/s co-directional interface (E0)

The EuroProt+ device supports line differential communication via telecom networks using G.703.1 64kbit/s co-directional interface type, that is synchronized to the network (timing slave). This type of communication is performed via 2*2 wire isolated galvanic type interface. The protection device is connected to a multiplexer or gateway which is responsible for protocol/speed conversion.

“G70364k: G703 module” and “DIFF87L” functions must be in the configuration.

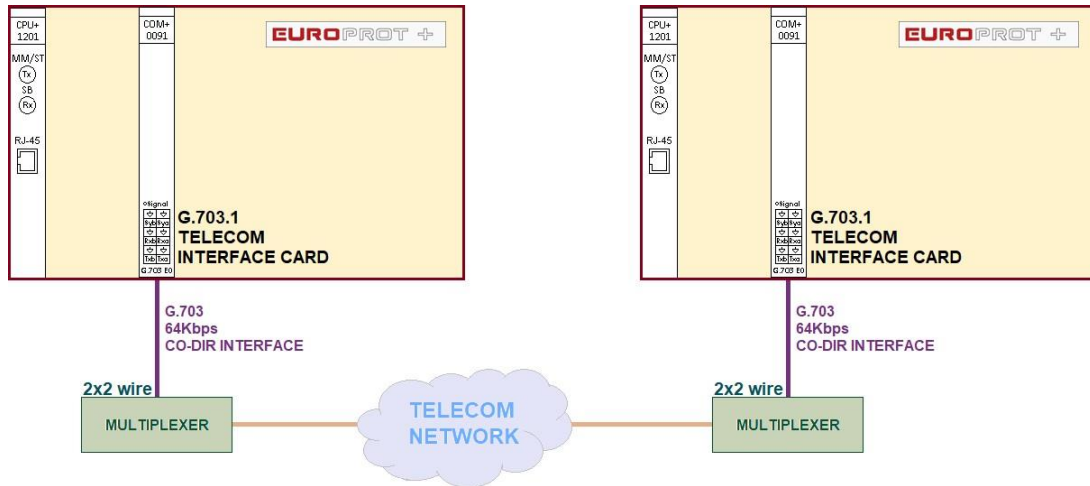

Figure 4-1 Schema of communication via G.703 64kbit/s co-directional interface

COMMUNICATION PARAMETERS	COMMENT
HDLC Adress (1-63)	Default value is: 1

3.4.2. Communication via 2.048Mbit/s (E1/T1) Nx64kbit/s interface

For availability please contact: sales@protecta.hu

EuroProt+ device supports line differential communication via telecom networks with G703/704 2.048Mbit/s interface (E1). Besides, E1 in European networks the T1 interface (1.54Mbit/s) in America also available.

“G703E1: G703 module” function and “DIFF87L” functions must be in the configuration.

CPU module with LDC – BB SFP interface with dedicated SFP module (MiRiCi-E1/T1 (Intelligent Miniature Ethernet to E1/T1) by RAD) is mandatory hardware for this option.

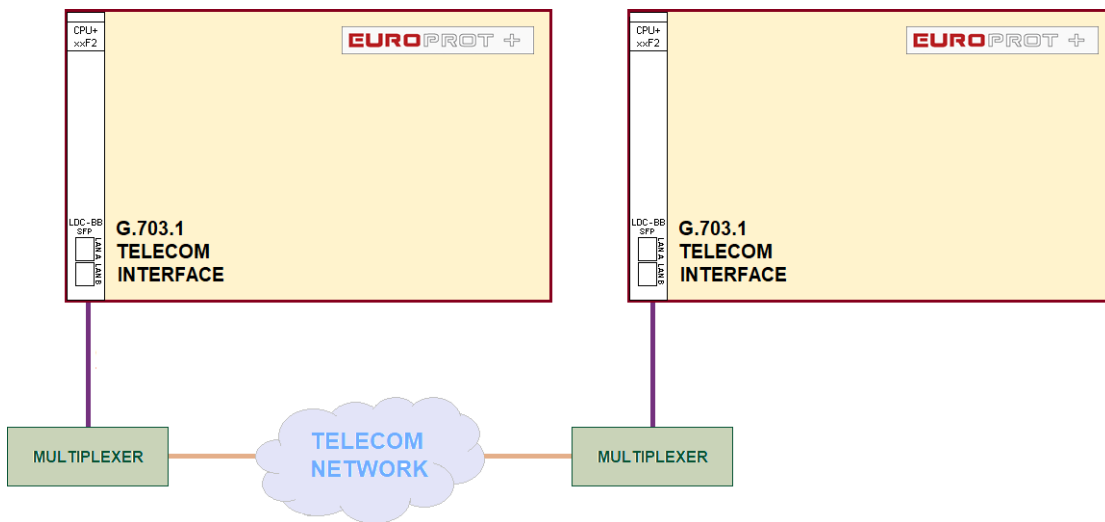

LDP – BB: Proprietary Process Bus for Line differential or Busbar communication

SFP: Small Form-factor Pluggable connector

Figure 4-2 Schema of communication via 2.048Mbit/s (E1/T1) Nx64kbit/s interface

Table 4-2 Communication via 2.048Mbit/s (E1/T1) Nx64kbit/s interface communication parameters

COMMUNICATION PARAMETERS	COMMENT
HDLC Adress (1-63)	Default value is: 1
HDLC Speed (n x 64kbit/s, n: 1-31)	Default value: 31
Start Timeslot (1-31)	Default value: 1

3.5. Redundant line differential communication

The data interchange over the two communication channels is carried out in parallel way which enables hot standby operation. In case of single point of failure in one of the links, the algorithm processes the data from the other link without switchover time.

3.5.1. G.703 and 100Base-FX redundancy

For availability please contact: sales@protecta.hu

Redundant communication also supported by EuroProt+. The high speed 100Base-FX link is used as main channel and G.703.1 leased or dedicated line as backup link. An extra COM+1091 or COM+8091 card needs to be added to the configuration for this kind of redundancy.

“G70364k: G703 module” and “DIFF87L3” functions must be in the configuration.

Module labels on the are samples only; other types of COM modules can also be used. The operation parameter of Line differential function must be “On Redu 2ends”.

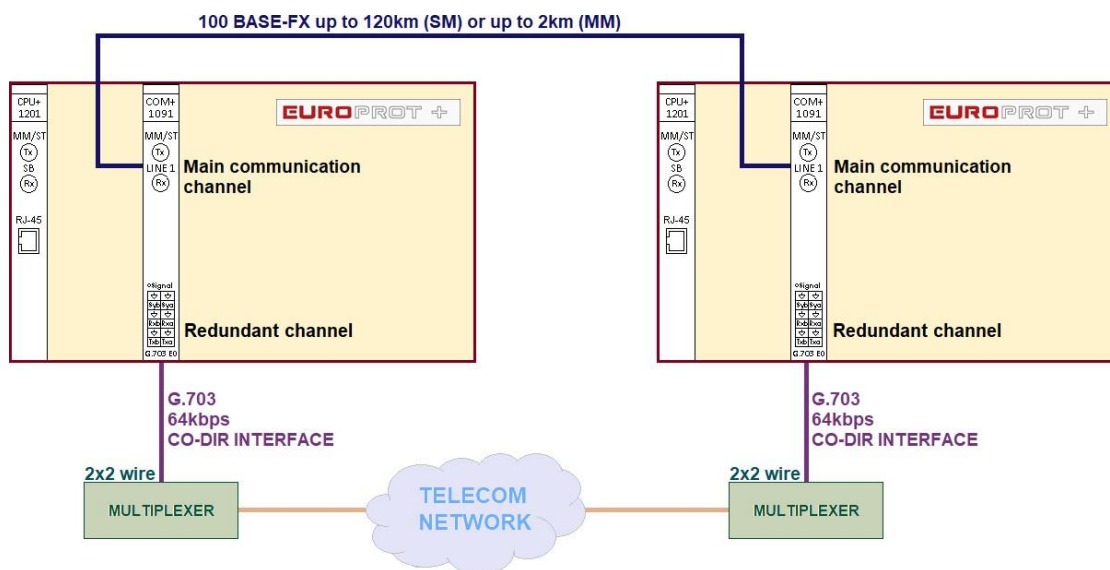

Figure 5-1 Schema of the communication via G.703 and 100Base-FX redundancy

Table 5-1 G.703 and 100Base-FX redundancy communication parameters

COMMUNICATION PARAMETERS	COMMENT
Main communication parameters	
Tx VLAN	Default values are: device 1: 2 device 2: 1
Rx VLAN	Default values are: device 1: 2 device 2: 1
Priority	VLAN priority (Default value is 4)
Mcast Addr	VLAN multicast address (Default value is 1)
Redundant communication parameters	
HDLC Address (1-63)	Default value is: 1

3.5.2. 100Base-FX redundancy

Both communication links are Ethernet 100Base-FX type and the connection type can be direct link (dark fiber) and/or a service from a telecom operator. An extra COM+1101 or COM+8801 or COM+9901 card needs to be added to the configuration for this kind of redundancy.

“COM2Dir: 2Dir. LD communication module” (previously “COM1101: COM1101 module”) and “DIFF87L3: Line Differential” functions must be in the configuration.

Module labels on the are samples only; other types of COM modules can also be used.

The operation parameter of Line differential function must be “On Redu 2ends”.

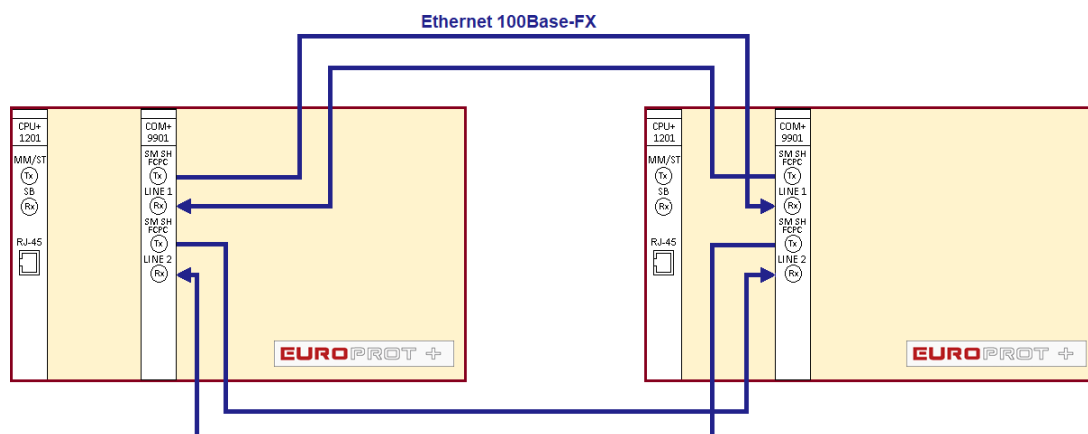

Figure 5-2 Schema of the communication via fiber optic cable with 100Base-FX redundancy

Table 5-2 100Base-FX redundancy communication parameters

COMMUNICATION PARAMETERS	COMMENT	VALUES
Tx VLAN Line1	Transmit VLAN ID for Line1	device1: 1 device2: 2
Rx VLAN Line1	Receive VLAN ID for Line1	device1: 2 device2: 1
Priority Line1	Line1 VLAN priority	4
Multicast Address Line1	Line1 VLAN multicast address	1
Tx VLAN Line2	Transmit VLAN ID for Line2	device1: 3 device2: 4
Rx VLAN Line2	Receive VLAN ID for Line2	device1: 4 device2: 3
Priority Line2	Line2 VLAN priority	4
Multicast Address Line2	Line2 VLAN multicast address	1

3.6. Three terminal line differential communication

With an additional communication card, the EuroProt+ device allows three terminal line differential communication between protections. The communication channel in this case is Ethernet 100Base-Fx. The three terminal line differential protection scheme can tolerate the link failure of one of the three communication channels between the devices.

“COM2Dir: 2Dir. LD communication module” (previously “COM1101: COM1101 module”) and “DIFF87L3: Line Differential” functions must be in the configuration. Module labels on the picture are samples only; other types of COM modules can also be used. The operation parameter of Line differential function have to be “On 3ends”.

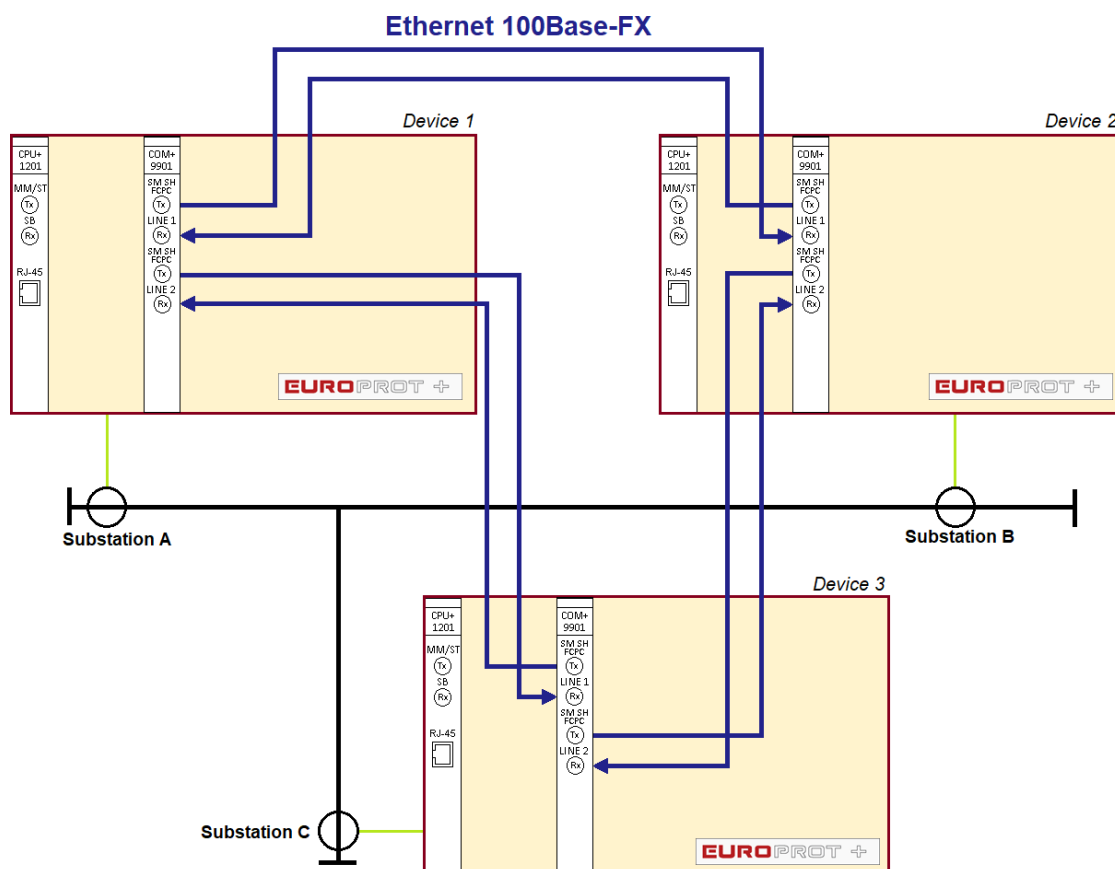

Figure 6-1 Schema of three line diff. communication

Table 6-1 Parameters of device 1

COMMUNICATION PARAMETERS	COMMENT	VALUES
Tx VLAN Line1	Transmit VLAN ID for Line1	1
Rx VLAN Line1	Receive VLAN ID for Line1	2
Priority Line1	Line1 VLAN priority	4
Multicast Address Line1	Line1 VLAN multicast address	1
Tx VLAN Line2	Transmit VLAN ID for Line2	1
Rx VLAN Line2	Receive VLAN ID for Line2	3
Priority Line2	Line2 VLAN priority	4
Multicast Address Line2	Line2 VLAN multicast address	1

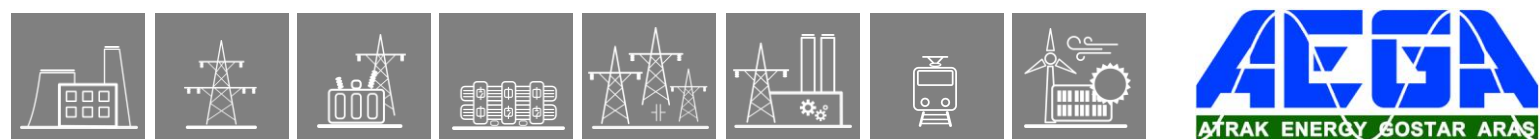

Table 6-2 Parameters of device 2

COMMUNICATION PARAMETERS	COMMENT	VALUES
Tx VLAN Line1	Transmit VLAN ID for Line1	2
Rx VLAN Line1	Receive VLAN ID for Line1	1
Priority Line1	Line1 VLAN priority	4
Multicast Address Line1	Line1 VLAN multicast address	1
Tx VLAN Line2	Transmit VLAN ID for Line2	2
Rx VLAN Line2	Receive VLAN ID for Line2	3
Priority Line2	Line2 VLAN priority	4
Multicast Address Line2	Line2 VLAN multicast address	1

Table 6-3 Parameters of device 3

COMMUNICATION PARAMETERS	COMMENT	VALUES
Tx VLAN Line1	Transmit VLAN ID for Line1	3
Rx VLAN Line1	Receive VLAN ID for Line1	1
Priority Line1	Line1 VLAN priority	4
Multicast Address Line1	Line1 VLAN multicast address	1
Tx VLAN Line2	Transmit VLAN ID for Line2	3
Rx VLAN Line2	Receive VLAN ID for Line2	2
Priority Line2	Line2 VLAN priority	4
Multicast Address Line2	Line2 VLAN multicast address	1

3.7. 2-ends line differential communication with three terminals

Normally there are three terminals in T-branch topology.

If one of three circuit breakers is switched off and the terminal in that bay is working, the customer/user does not need to do anything.

If one of three circuit breakers is switched off and the terminal in that bay is not working, the “Map L2 to L1” must be chosen in some cases. This setting depends on the fiber optic connection of terminals. Mapping means redirecting measured analogue values from Connector2 to Connector1 in communication module. This behavior is necessary for the correct calculation of differential current in line differential function.

You can see the different situations below.

“COM2Dir: 2Dir. LD communication module” (previously “COM1101: COM1101 module”) and “DIFF87L3: Line Differential” functions must be in the configuration

COM module labels are on the picture are samples only, other COM modules can also be used. The operation parameter of Line differential function must be “On 2ends”.

3.7.1. Variant 1

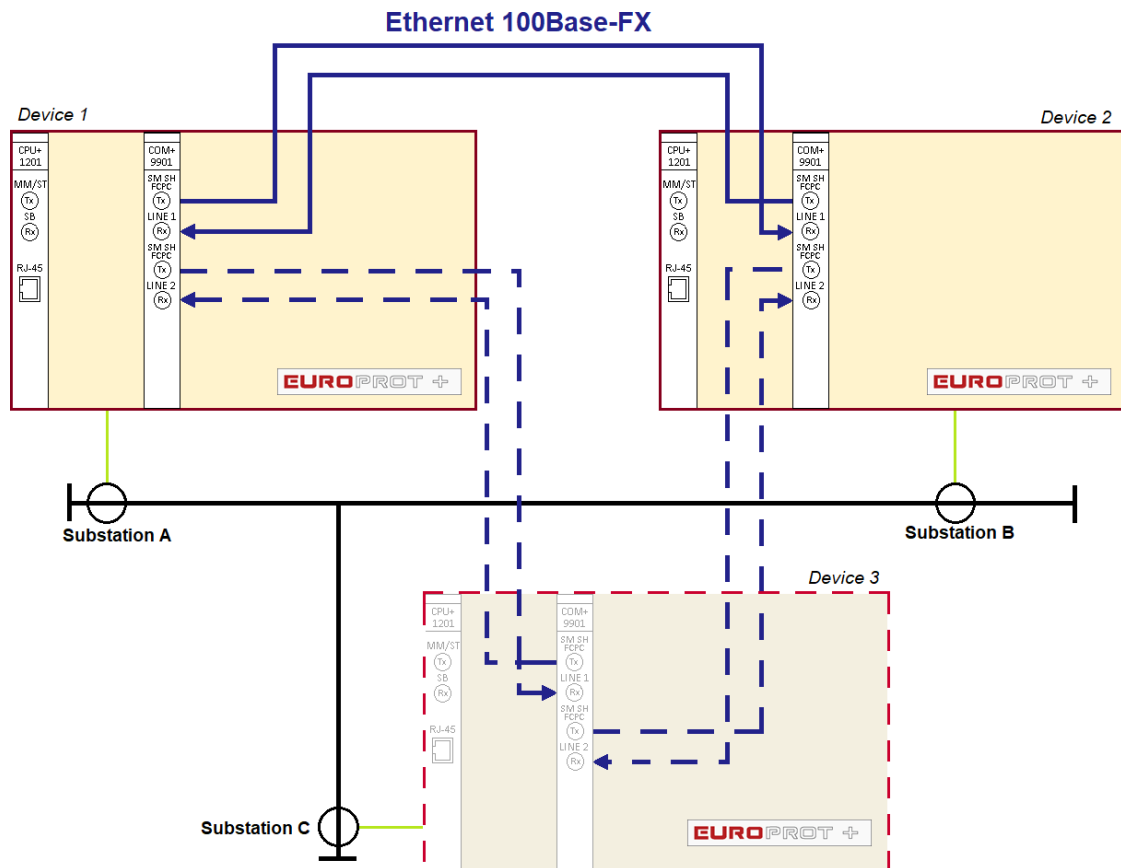

Figure 7-1 Schema of 2 ends line diff. communication with three terminals, variant 1

Table 7-1 Parameters of device 1

COMMUNICATION PARAMETERS	COMMENT	VALUES
Tx VLAN Line1	Transmit VLAN ID for Line1	1
Rx VLAN Line1	Receive VLAN ID for Line1	2
Priority Line1	Line1 VLAN priority	4
Mcast Addr Line1	Line1 VLAN multicast address	1
Tx VLAN Line2	Transmit VLAN ID for Line2	1
Rx VLAN Line2	Receive VLAN ID for Line2	3
Priority Line2	Line2 VLAN priority	4
Mcast Addr Line2	Line2 VLAN multicast address	1
Map L2 to L1	Mapping the analogue values	No

Table 7-2 Parameters of device 2

COMMUNICATION PARAMETERS	COMMENT	VALUES
Tx VLAN Line1	Transmit VLAN ID for Line1	1
Rx VLAN Line1	Receive VLAN ID for Line1	2
Priority Line1	Line1 VLAN priority	4
Mcast Addr Line1	Line1 VLAN multicast address	1
Tx VLAN Line2	Transmit VLAN ID for Line2	2
Rx VLAN Line2	Receive VLAN ID for Line2	3
Priority Line2	Line2 VLAN priority	4
Mcast Addr Line2	Line2 VLAN multicast address	1
Map L2 to L1	Mapping the analogue values	No

3.7.2. Variant 2

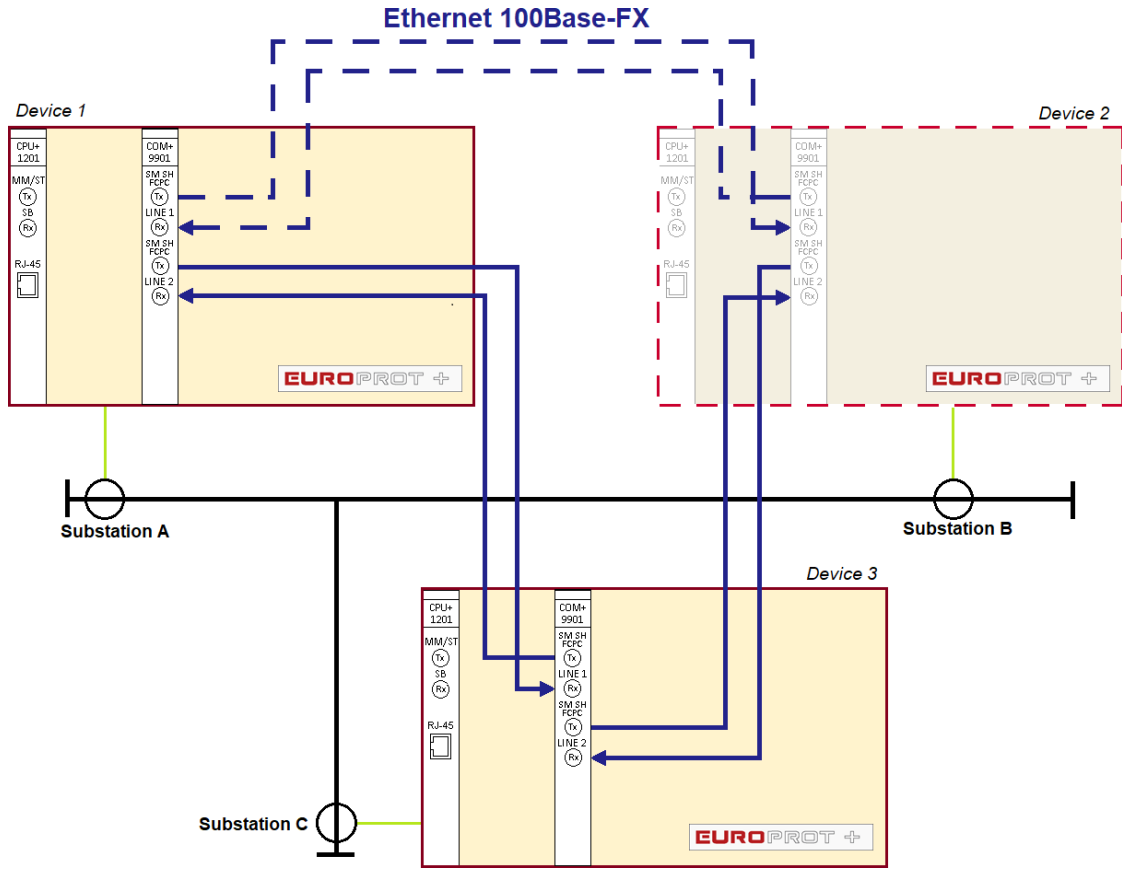

Figure 7-2 Schema of 2 ends line diff. communication with three terminals, variant 2

Table 7-3 Parameters of device 1

COMMUNICATION PARAMETERS	COMMENT	VALUES
Tx VLAN Line1	Transmit VLAN ID for Line1	1
Rx VLAN Line1	Receive VLAN ID for Line1	2
Priority Line1	Line1 VLAN priority	4
Mcast Addr Line1	Line1 VLAN multicast address	1
Tx VLAN Line2	Transmit VLAN ID for Line2	1
Rx VLAN Line2	Receive VLAN ID for Line2	3
Priority Line2	Line2 VLAN priority	4
Mcast Addr Line2	Line2 VLAN multicast address	1
Map L2 to L1	Mapping the analogue values	Yes

Table 7-4 Parameters of device 3

COMMUNICATION PARAMETERS	COMMENT	VALUES
Tx VLAN Line1	Transmit VLAN ID for Line1	3
Rx VLAN Line1	Receive VLAN ID for Line1	1
Priority Line1	Line1 VLAN priority	4
Mcast Addr Line1	Line1 VLAN multicast address	1

Tx VLAN Line2	Transmit VLAN ID for Line2	3
Rx VLAN Line2	Receive VLAN ID for Line2	2
Priority Line2	Line2 VLAN priority	4
Mcast Addr Line2	Line2 VLAN multicast address	1
Map L2 to L1	Mapping the analogue values	No

3.7.3. Variant 3

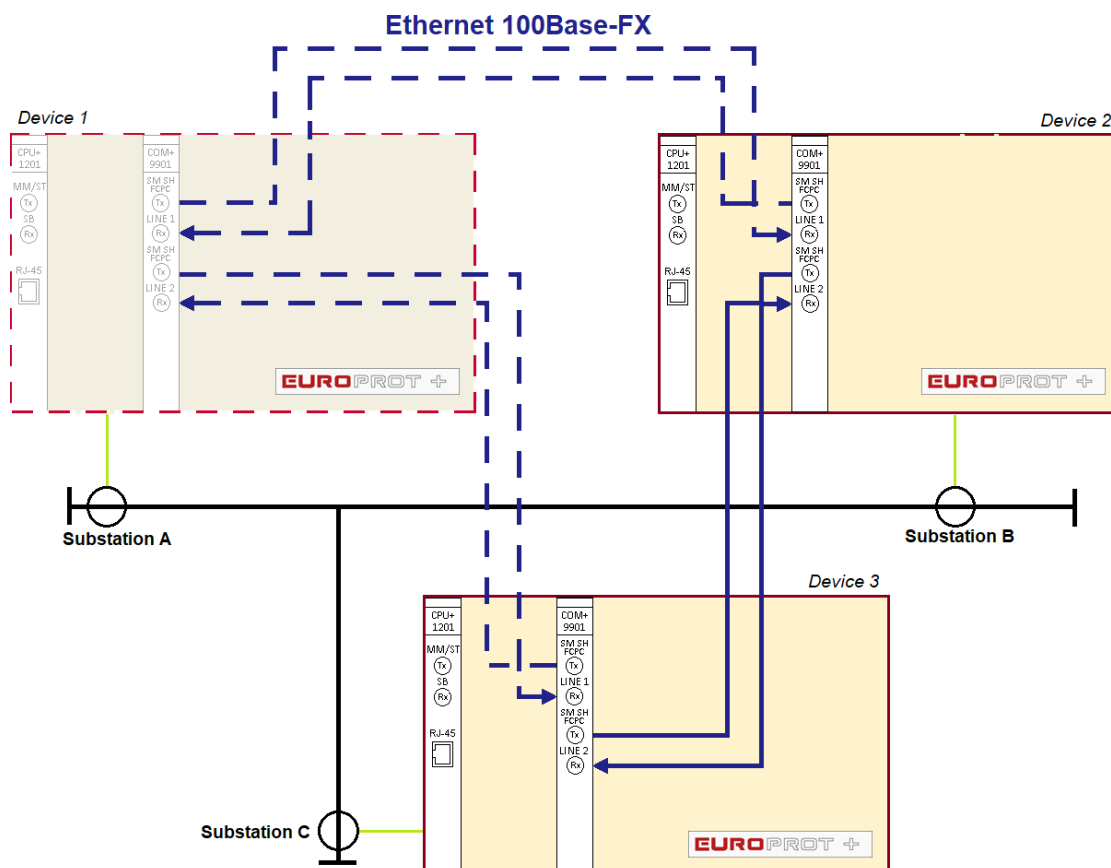

Figure 7-3 Schema of 2 ends line diff. communication with three terminals, variant 3

Table 7-5 Parameters of device 2

COMMUNICATION PARAMETERS	COMMENT	VALUES
Tx VLAN Line1	Transmit VLAN ID for Line1	2
Rx VLAN Line1	Receive VLAN ID for Line1	1
Priority Line1	Line1 VLAN priority	4
Mcast Addr Line1	Line1 VLAN multicast address	1
Tx VLAN Line2	Transmit VLAN ID for Line2	2
Rx VLAN Line2	Receive VLAN ID for Line2	3
Priority Line2	Line2 VLAN priority	4
Mcast Addr Line2	Line2 VLAN multicast address	1
Map L2 to L1	Mapping the analogue values	Yes

Table 7-6 Parameters of device 3

COMMUNICATION PARAMETERS	COMMENT	VALUES
Tx VLAN Line1	Transmit VLAN ID for Line1	3
Rx VLAN Line1	Receive VLAN ID for Line1	1
Priority Line1	Line1 VLAN priority	4
Mcast Addr Line1	Line1 VLAN multicast address	1
Tx VLAN Line2	Transmit VLAN ID for Line2	3
Rx VLAN Line2	Receive VLAN ID for Line2	2
Priority Line2	Line2 VLAN priority	4
Mcast Addr Line2	Line2 VLAN multicast address	1
Map L2 to L1	Mapping the analogue values	Yes

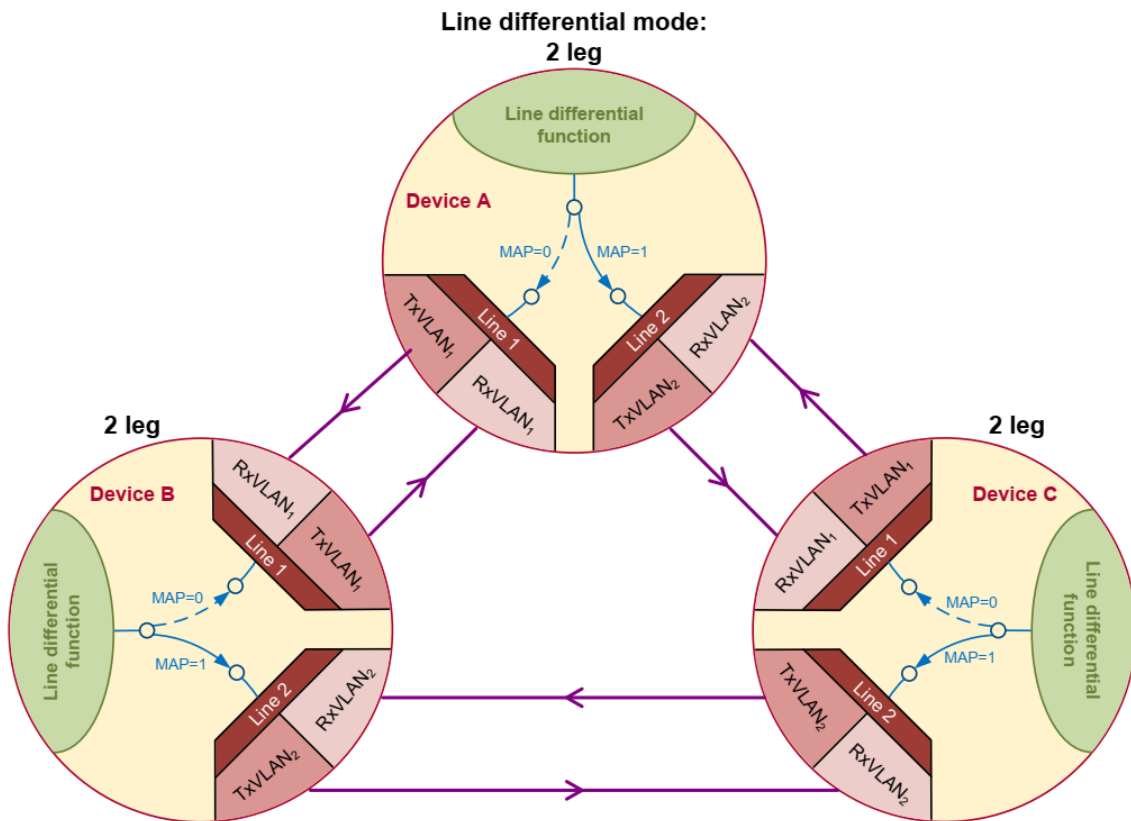

Figure 7-4 Communication schema of 2 ends line diff. used on 3 terminals

3.8. Remote binary signal transmission

3.8.1. Direct link communication

In case of a dark fiber is available between two substations or between two devices at the substation the peer-to-peer communication mode is recommended. For short-haul applications, that is limited to 2km the multi-mode fiber or up to 50km single mode 1550nm fiber can be used. Long-haul applications up to 35dB line attenuation, that is 100-120km in practice, the single mode 1550nm fiber can be used.

“COM1Dir: 1Dir. Communication module” (previously “CPUeth: CPU LDC module”) and “REMBIN1: 16Ch Binary signal transmission” functions must be in the configuration.

The “REMBIN1: 16Ch Binary signal transmission” function block can send and receive 16 signals which is to be configured in the Logic Editor of the EuroCAP tool.

If more than 16 signals transmission is needed, one „REMBIN1_16Add: 16Ch additional binary signal transm.” function block can be used in the configuration. This shall be added to the user logic as well.

Maximum number of transferable signals is 32.

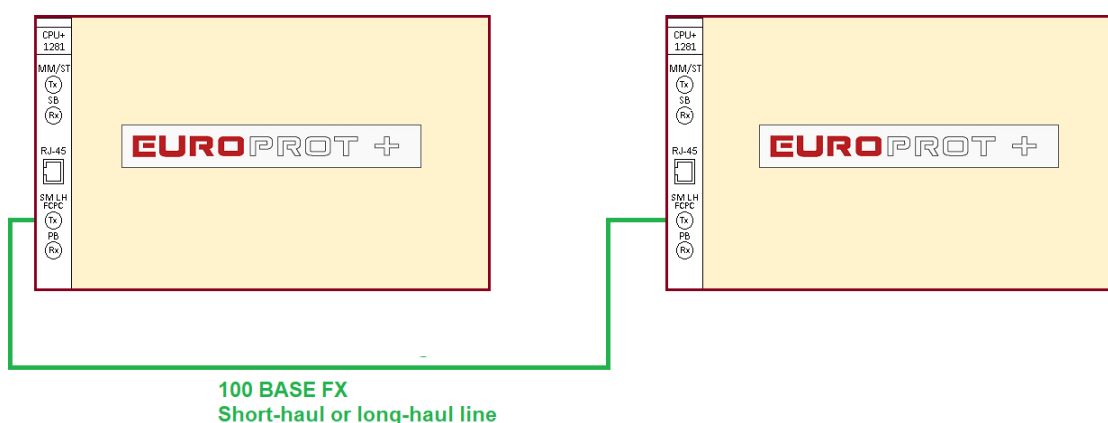

Figure 8-1 Schema of the direct link communication for rem. bin. transmission

Table 8-1 Communication parameters of direct link communication for rem. bin. transmission

COMMUNICATION PARAMETERS	COMMENT
Tx VLAN (1-4096)	Transmit VLAN ID Default values are: device 1:1 device 2:2
Rx VLAN	Receive VLAN ID Default values are: device 1:2 device 2:1
Priority (0-7)	VLAN priority (Default value is 4)
Multicast (0 - 65535)	VLAN multicast address (Default value is 1)

3.8.2. Three or more terminals binary signal transmission

In some special applications, signals are to be transferred among many devices either in ring or in meshed network topology within or between substations. A four devices example is below.

“COM3Dir: 2 or 3Dir. bin. signal transm. module” and “REMBIN3: 3Dir. binary signal transmission” functions must be in the configuration.

In case of 2 directional use (e.g. if COM+/9902 is used), all Grl statuses of third direction shall be hidden and all I/Os of third direction shall be deleted from FB in configuration. TX, RX parameters of Line 3 shall be set to different values than other communications (e.g. 3127) and hidden in COMM3Dir function block.

The “REMBIN3” function block can send and receive in 3 directions 10-10-9 signals which can be configured in the Logic Editor of EuroCAP tool.

The COM module labels on the picture are samples only, other types of COM modules also can be used.

Note that the third connector/direction of communication module in Device 1 and Device 4 has no connection to anywhere, communication failure in direction 3 is generated in this case.

These two devices (1 and 4) can connect if binary signal transmission is necessary between them. Topology can be expanded with additional devices which can be connected to Device 1, Device 4 or both in this example.

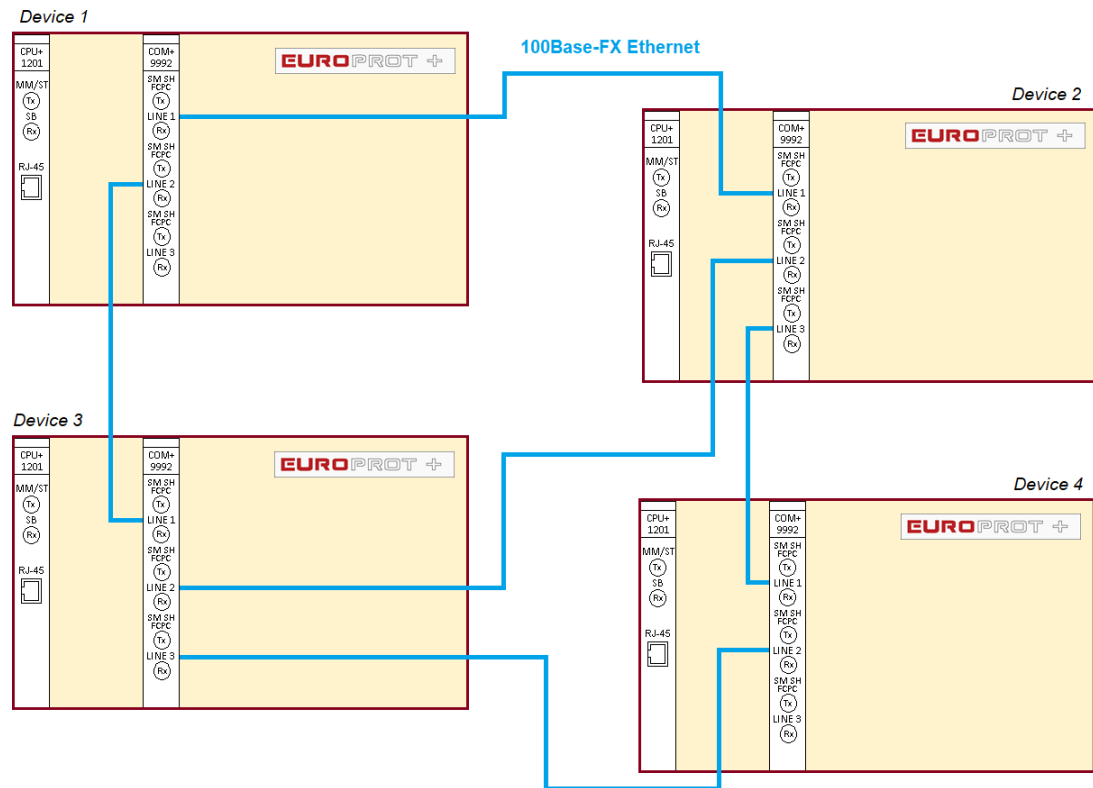

Figure 8-2 Schema of the multi-terminal communication for rem. bin. transmission

Table 8-2 Communication parameters of Device 1

COMMUNICATION PARAMETERS	COMMENT	VALUES
Priority	VLAN priority	4
Tx VLAN Line1	Transmit VLAN ID for Line1	1
Rx VLAN Line1	Receive VLAN ID for Line1	2
Mcast Addr Line1	Line1 VLAN multicast address	1
Tx VLAN Line2	Transmit VLAN ID for Line2	1
Rx VLAN Line2	Receive VLAN ID for Line2	3
Mcast Addr Line2	Line2 VLAN multicast address	1
Parameters of Line 3 are hidden if COM+/9902 is used		
Tx VLAN Line3	Transmit VLAN ID for Line3	1
Rx VLAN Line3	Receive VLAN ID for Line3	Different than other parameters in every devices
Mcast Addr Line3	Line3 VLAN multicast address	1

Table 8-3 Communication parameters of Device 2

COMMUNICATION PARAMETERS	COMMENT	VALUES
Priority	VLAN priority	4
Tx VLAN Line1	Transmit VLAN ID for Line1	2
Rx VLAN Line1	Receive VLAN ID for Line1	1
Mcast Addr Line1	Line1 VLAN multicast address	1
Tx VLAN Line2	Transmit VLAN ID for Line2	2
Rx VLAN Line2	Receive VLAN ID for Line2	3
Mcast Addr Line2	Line2 VLAN multicast address	1
Tx VLAN Line3	Transmit VLAN ID for Line3	2
Rx VLAN Line3	Receive VLAN ID for Line3	4
Mcast Addr Line3	Line3 VLAN multicast address	1

Table 8-4 Communication parameters of Device 3

COMMUNICATION PARAMETERS	COMMENT	VALUES
Priority	VLAN priority	4
Tx VLAN Line1	Transmit VLAN ID for Line1	3
Rx VLAN Line1	Receive VLAN ID for Line1	1
Mcast Addr Line1	Line1 VLAN multicast address	1
Tx VLAN Line2	Transmit VLAN ID for Line2	3
Rx VLAN Line2	Receive VLAN ID for Line2	2
Mcast Addr Line2	Line2 VLAN multicast address	1
Tx VLAN Line3	Transmit VLAN ID for Line3	3
Rx VLAN Line3	Receive VLAN ID for Line3	4
Mcast Addr Line3	Line3 VLAN multicast address	1

Table 8-5 Communication parameters of Device 4

COMMUNICATION PARAMETERS	COMMENT	VALUES
Priority	VLAN priority	4
Tx VLAN Line1	Transmit VLAN ID for Line1	4
Rx VLAN Line1	Receive VLAN ID for Line1	2
Mcast Addr Line1	Line1 VLAN multicast address	1
Tx VLAN Line2	Transmit VLAN ID for Line2	4
Rx VLAN Line2	Receive VLAN ID for Line2	3
Mcast Addr Line2	Line2 VLAN multicast address	1
Parameters of Line 3 are hidden if COM+/9902 is used		
Tx VLAN Line3	Transmit VLAN ID for Line3	4
Rx VLAN Line3	Receive VLAN ID for Line3	Different than other parameters in every device
Mcast Addr Line3	Line3 VLAN multicast address	1

3.9. Communication interface characteristics

3.9.1. Ethernet multi-mode transmitter and receiver

This interface is for applications up to approximately 2 km.

Table 9-1 Parameters of the Transmitter

PARAMETER	SYMBOL	MIN.	TYP.	MAX.	UNIT
Optical Output Power 62.5/125 μm , NA=0.275 fiber	P_0	-19 -20		-14	dBm avg
Optical Output Power 50/125 μm , NA=0.20 fiber	P_0	-22.5 -23.5		-14	dBm avg
Optical Extinction Ratio				10 -10	% dB
Center Wavelength	λ_c	1270	1308	1380	nm

The receiver sensitivity is measured with $2^{23} - 1$ PRBS pattern within $\text{BER} = 2.5 \times 10^{-10}$.

Table 9-2 Parameters of the Receiver

PARAMETER	SYMBOL	MIN.	TYP.	MAX.	UNIT
Signal Detect – Asserted	P_a			-33	dBm avg.
Signal Detect - Deasserted	P_d				dBm avg.
Signal Detect - Hysteresis	$P_a - P_d$				dB
Signal Detect Assert Time (off to on)	AS_Max		2	100	μs
Signal Detect Deassert Time (on to off)	ANS_Max		8	350	μs

3.9.2. Ethernet single mode transmitter and receiver

3.9.2.1. Long haul single mode transceiver

This interface is for applications up to approximately 120 km, with max. 32 dB link attenuation.

Table 9-3 Parameters of the Transmitter

PARAMETER	SYMBOL	MIN.	TYP.	MAX.	UNIT
Optical Output Power (avg.)	P_0	-6		0	dBm
Extinction Ratio	ER	8.3			dB
Optical Wavelength	λ_c	1490	1550	1610	Nm

Table 9-4 Parameters of the Receiver

PARAMETER	SYMBOL	MIN.	TYP.	MAX.	UNIT
Optical Input Sensitivity (avg.)	P_{in}		-38	-35	dBm
Saturation	P_{sat}	-3	0		dBm
Optical Wavelength	λ	1100		1600	nm
Signal Detect Asserted (avg.)	P_a			-35	dBm
Signal Detected Deasserted (avg.)	P_d	-45			dBm
Hysteresis	P_{hys}		3		dB

3.9.2.2. Short haul single mode transceiver

This interface is for applications up to approximately 120 km, with max. 32 dB link attenuation.

Table 9-5 Parameters of the Transmitter

PARAMETER	SYMBOL	MIN.	TYP.	MAX.	UNIT
Optical Output Power (avg.)	P_0	-12		-6	dBm
Extinction Ratio	ER	8.3			dB
Optical Wavelength	λ_c	1490	1550	1610	Nm

Table 9-6 Parameters of the Receiver

PARAMETER	SYMBOL	MIN.	TYP.	MAX.	UNIT
Optical Input Sensitivity (avg.)	P_{in}		-38	-35	dBm
Saturation	P_{sat}	-3	0		dBm
Optical Wavelength	λ	1100		1600	nm
Signal Detect Asserted (avg.)	P_a			-35	dBm
Signal Detected Deasserted (avg.)	P_d	-45			dBm
Hysteresis	P_{hys}		3		dB

3.9.3. G.703 64kbit/s co-directional interface (E0)

Interface type: G.703.1 64 kbit/s (E0) co-directional, selectable grounding, with optional external clock input.

Connector type

Receptacle	Weidmüller S2L 3.50/12/90 F
Plug	Weidmüller B2L 3.50/12/180 F

Impedance	120 Ω
Cable length	50 m

Receiver

Loss of Signal Alarm Level	± 1.5 dB Difference Between Alarm-on and Alarm-off
Dynamic Range	10 dB Maximum Cable Loss Range

Transmitter

Pair for each direction	One symmetric pair
Test load impedance	120 Ω resistive
Nominal peak voltage of a „mark” (pulse)	1.0 V
Peak voltage of a „space” (no pulse)	0 V \pm 0.10 V
Nominal pulse width	3.9 ms
Ratio of the amplitudes of positive and negative pulses at the center of the pulses interval	0.95 to 1.05
Ratio of the widths of positive and negative pulses at the nominal half amplitude	0.95 to 1.05
Maximum peak-to-peak jitter at the output port	Refer to clause 2/G.823

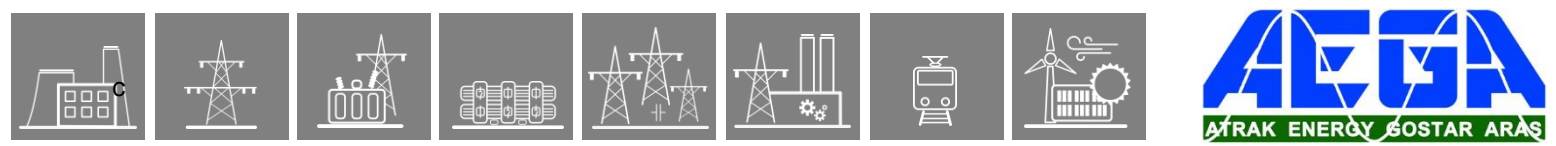

3.9.4. 2.048Mbit/s (E1/T1) Nx64kbit/s interface

MiRiCi E1 interface

Number of Ports	1
Compliance	G.703, G.704, G.775, G.823
Data Rate	2.048 Mbps
Line Code	HDB3, AMI
Framing	Framed (G.732.N, G.732.N CRC), unframed
Line Impedance	120W, balanced
Cable Length	Up to 2500m (8202 ft) for AWG 22 cable
Connector	RJ-45

4. Software configuration

4.1. Protection functions

The E2-Line configuration measures three phase currents, the zero sequence current component of the parallel line and additionally three phase voltages and the busbar voltage. These measurements allow, in addition to the current- and voltage-based functions, directionality extension of the configured phase overcurrent and residual overcurrent function and also directional overpower or underpower functions.

There are two main protection functions in this application: they are the distance protection function and also the line differential protection function.

The distance protection function can generate three-phase or single phase trip commands, depending on the fault types and the requirements.

The communication hardware module sends and receives phase current vectors to realize the line differential protection function. The choice of the functions is extended with the automatic reclosing function, synchro-check and switch-onto-fault logic.

Based on the voltage measurement also the frequency is evaluated to realize frequency-based protection functions.

The configured protection functions are listed in the Table below.

Protection functions	IEC	ANSI	E2-Line
Three-phase instantaneous overcurrent protection	$I >>>$	50	X
Three-phase time overcurrent protection	$I >, I >>$	51	X
Three-phase directional overcurrent protection	$I \text{ Dir } > >, I \text{ Dir } >>$	67	X
Residual instantaneous overcurrent protection	$I_0 >>>$	50N	X
Residual time overcurrent protection	$I_0 >, I_0 >>$	51N	X
Residual directional overcurrent protection	$I_0 \text{ Dir } > >, I_0 \text{ Dir } >>$	67N	X
Line differential	$3I_d L >$	87L	X
Distance protection	$Z <$	21	X
Out-of-step	$\Delta Z / \Delta t$	78	X
Power swing block		68	X
Inrush detection and blocking	$I_{2h} >$	68	X
Negative sequence overcurrent protection	$I_2 >$	46	X
Thermal protection	$T >$	49	X
Definite time overvoltage protection	$U >, U >>$	59	X
Definite time undervoltage protection	$U <, U <<$	27	X
Residual overvoltage protection	$U_0 >, U_0 >>$	59N	X
Negative sequence overvoltage protection	$U_2 >$	47	X
Overfrequency protection	$f >, f >>$	81O	X
Underfrequency protection	$f <, f <<$	81U	X
Rate of change of frequency protection	df/dt	81R	X

Synchrocheck	SYNC	25	X
Auto-reclose	0 - > 1	79	X
Fuse failure (VTS)		60	X
Current unbalance protection		60	X
Switch onto fault logic			X
Breaker failure protection	CBFP	50BF	X
Directional overpower	P >	32	X
Directional underpower	P <	32	X

Table 1 The protection functions of the E2-Line configuration

The configured functions are drawn symbolically in the Figure below.

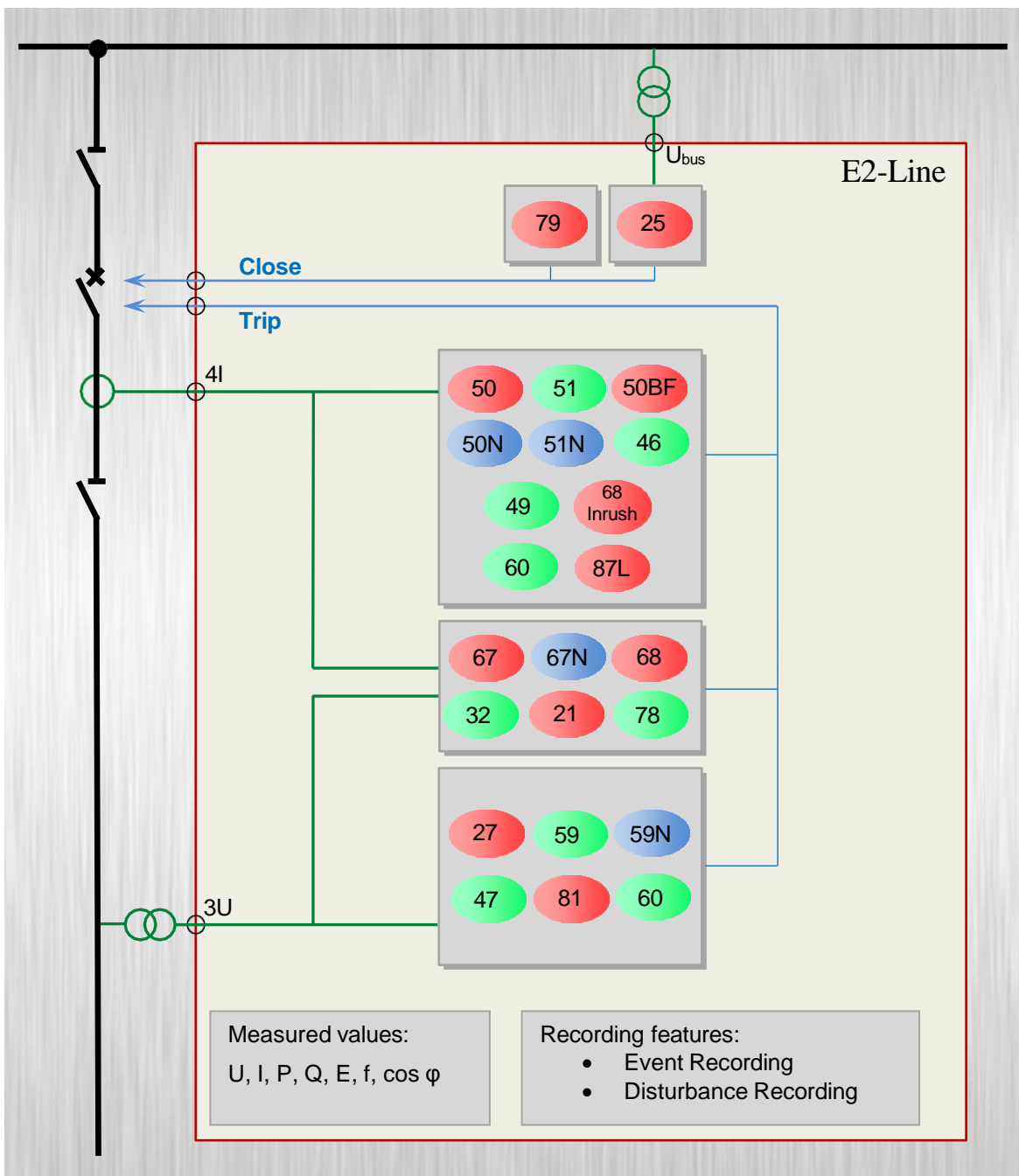
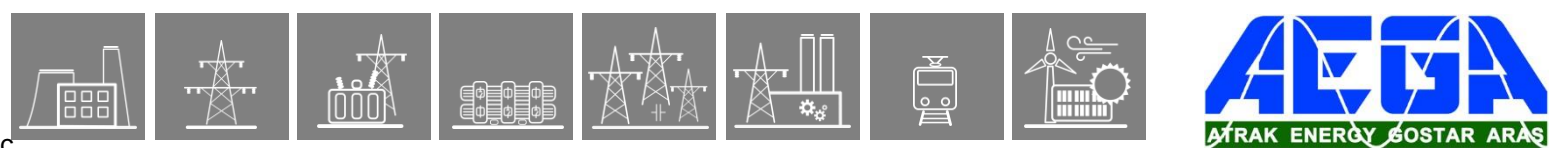

Figure 1 Implemented protection functions



4.1.1. Distance protection function

4.1.1.1. Operation principle

The distance protection function provides main protection for overhead lines and cables of solidly grounded networks. Its main features are as follows:

- A full-scheme system provides continuous measurement of impedance separately in three independent phase-to-phase measuring loops as well as in three independent phase-to-earth measuring loops.
- The complex earth fault compensation factor is applied for correct impedance measuring on single-phase-to-earth fault.
- Analogue input processing is applied to the zero sequence current of the parallel line.
- Impedance calculation is conditional of the values of phase currents being sufficient. The current is considered to be sufficient for impedance calculation if it is above the level set by parameter(s).
- To decide the presence or absence of the zero sequence current, biased characteristics are applied.
- Full-scheme faulty phase identification by minimum impedance detection.
- Five independent distance protection zones are configured.
- The operating decision is based on polygon-shaped characteristics.

- Load encroachment characteristics can be selected,
- The directional decision is dynamically based on:
 - measured loop voltages if they are sufficient for decision,
 - healthy phase voltages if they are available for asymmetrical faults,
 - voltages stored in the memory if they are available,
- The operation of any zones is non-directional if it is optionally selected.
- The distance protection function can operate properly if CVT is applied as well.
- Non-directional impedance protection function or high speed OC protection function is applied in case of switch-onto-fault.
- Distance-to-fault evaluation is implemented (fault locator function).
- Binary input signals and conditions can influence the operation:
 - blocking/enabling
 - VT failure signal
- Integrated high-speed overcurrent back-up function is also implemented.
- The power swing detection function can block the distance protection function in case of stable swings, or it can generate a trip command if the system operates out of step.

4.1.1.1.1. Structure of the distance protection algorithm

Figure 1-1 shows the structure of the 5-zone HV Distance protection (DIS21_HV) algorithm.

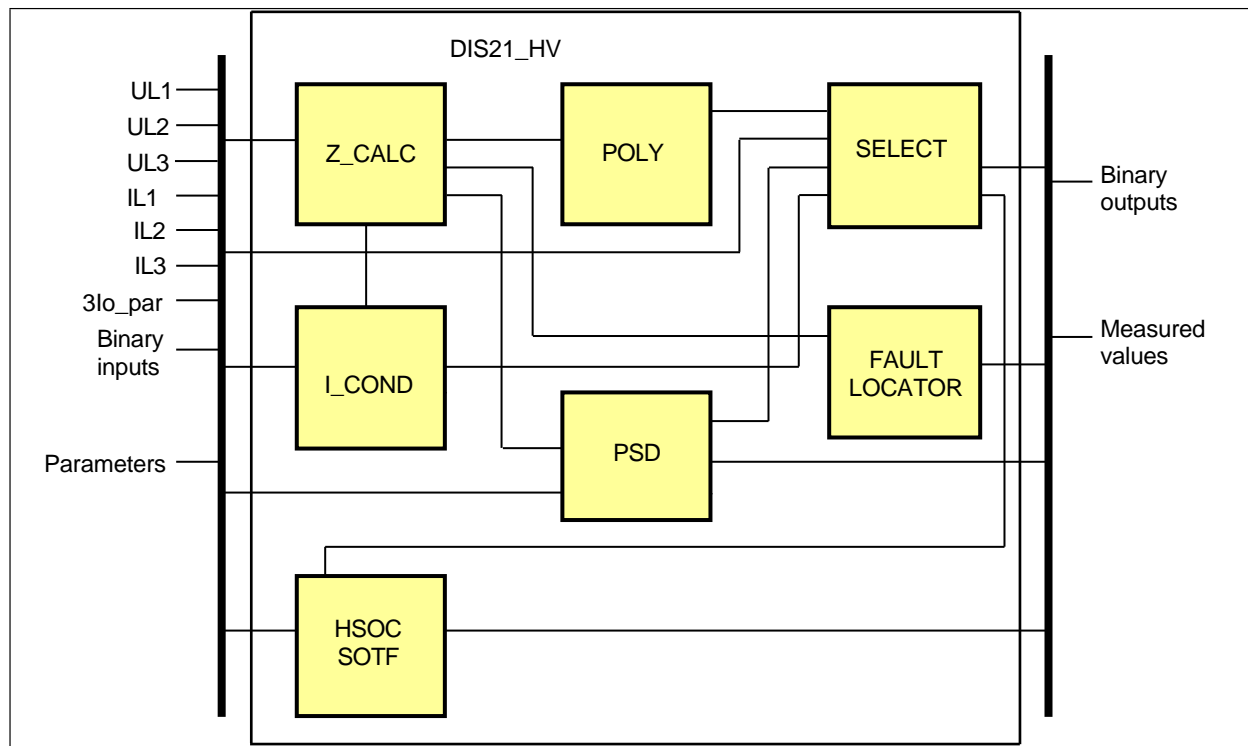

Figure 1-1 Structure of the distance protection algorithm

The inputs are

the Fourier components of three phase voltages,
the Fourier components of three phase currents,
the Fourier components of (3I_{0p}) the zero sequence current of the parallel line,
binary inputs,
parameters.

The outputs are

the binary output status signals,
the measured values for displaying.

The **software modules** of the distance protection function are as follows:

Z_CALC calculates the impedances ($R+jX$) of the six measuring current loops:

three phase-phase loops,
three phase-ground loops.

POLY compares the calculated impedances with the setting values of the five polygon characteristics. The result is the decision for all six measuring loops and for all five polygons if the impedance is within the polygon.

SELECT is the phase selection algorithm for all five zones to decide which decision is caused by a faulty loop and to exclude the false decisions in healthy loops.

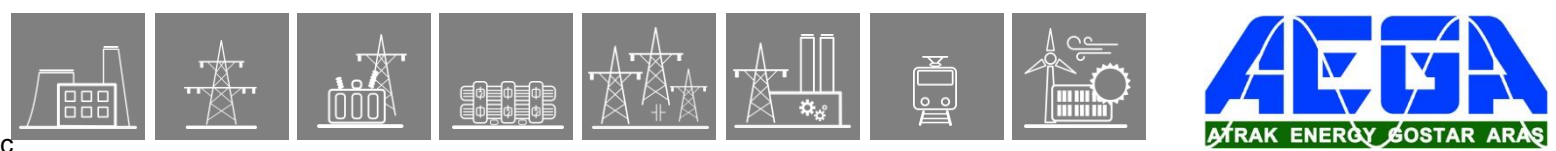

I_COND calculates the current conditions necessary for the impedance calculation and for the phase selection logic.

PSD is the module that detects power swings and generates out-of-step trip command, influencing the distance protection function.

FAULT LOCATOR calculates the distance to fault after the trip command.

HSOC SOTF is a high-speed overcurrent protection function for the switch-onto-fault logic.

The following description explains the details of the individual components.



Table 1-1 shows that the formula containing the complex earth fault compensation factor yields the correct impedance value in case of phase-to-earth faults only; the other formula can be applied in case of phase-to-phase faults without ground. In case of other kinds of faults (three-phase (-to-earth), phase-to-phase-to-earth) both formulas give the correct impedance value if the appropriate voltages and currents are applied.

The separation of the two types of equations is based on the presence or absence of the earth (zero sequence) current. In case of a fault involving the earth (on a solidly grounded network), and if the earth current is over a certain level, the formula containing the *complex* earth fault compensation factor will be applied to calculate the correct impedance, which is proportional to the distance-to-fault.

It can be proven that if the setting value of the *complex* earth fault compensation factor is correct, the appropriate application of the formulas in Table 1-1 will always yield the positive sequence impedance between the fault location and the relay location.

4.1.1.1.2.2. General method of calculation of the impedances of the fault loops

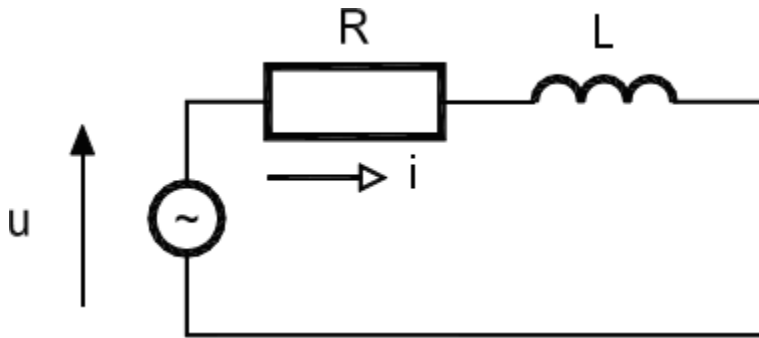

Figure 1-2 Equivalent circuit of the fault loop

For the equivalent impedance elements of the fault loop on the figure above, the following differential equation can be written:

$$u = Ri + L \frac{di}{dt}$$

If the real and the imaginary components of current and voltage phasors are substituted in this equation, two equations are derived with the two unknown values R and L , so they can be calculated.

This basic principle is realized in the algorithm by substituting the phasor components of the line-to-line voltages for u and the difference of two phase currents in case of two- or three-phase faults without ground for i . For example, in case of an L2L3 fault:

$$u_{L2} - u_{L3} = R_1(i_{L2} - i_{L3}) + L_1 \frac{d(i_{L2} - i_{L3})}{dt}$$

In case of a phase-to-earth fault, the phasor components of the phase voltage and the phase current modified by the zero sequence current have to be substituted:

$$u_{L1} = R_1(i_{L1} + \alpha_R 3i_o + \beta_R 3i_{op}) + L_1 \frac{d}{dt}(i_{L1} + \alpha_L 3i_o + \beta_L 3i_{op})$$

Where

- R_1 is the positive sequence resistance of the line or cable section between the fault location and the relay location,
- L_1 is the positive sequence inductance of the line or cable section between the fault location and the relay location,
- $L1$ is the faulty phase,
- $3i_o = iL1 + iL2 + iL3$ is the phasor component of the zero sequence current of the protected line,
- $3i_{op} = iL1_p + iL2_p + iL3_p$ is the phasor component of the zero sequence current in parallel line, and

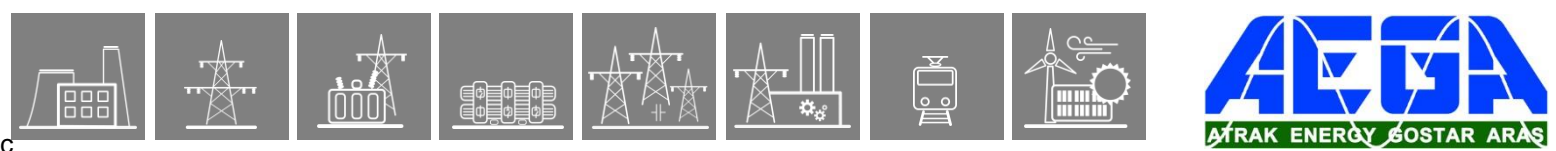

$$\alpha_R = \frac{R_o - R_1}{3R_1}$$

$$\alpha_L = \frac{L_o - L_1}{3L_1} = \frac{X_o - X_1}{3X_1}$$

$$\beta_R = \frac{R_m}{3R_1}$$

$$\beta_L = \frac{L_m}{3L_1} = \frac{X_m}{3X_1}$$

R_m is the real part of the mutual impedance between the protected and the parallel line,

L_m is the mutual inductance between the protected and the parallel line.

The formula above shows that the factors for multiplying the R and L values contain different “ α ” and “ β ” factors but they are real (not complex) numbers.

The applied numerical method is solving the differential equation of the faulty loop, based on three consecutive samples.

4.1.1.1.2.3. The principal scheme of the impedance calculation

Figure 1-3 shows the principal scheme of the impedance calculation Z_CALC

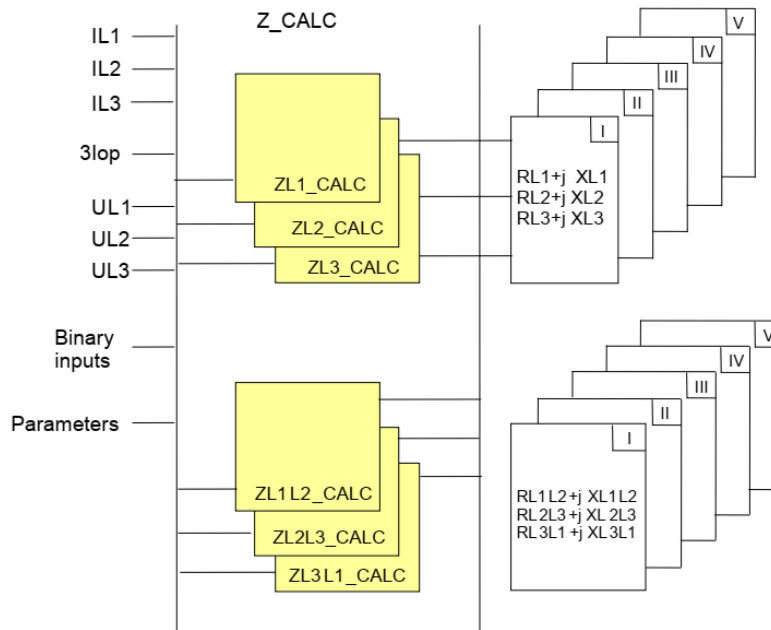

Figure 1-3 Principal scheme of the impedance calculation Z_Calc

The **inputs** are the Fourier components of:

- the three phase voltages,
- the three phase currents,
- the (3Iop) zero sequence current of the parallel line,
- binary inputs,
- parameters.

The binary inputs are signals influencing the operation of the distance protection function. These signals are the results of logic equations graphically edited by the user.

Table 1-2 Binary input signals for the impedance calculation

BINARY INPUT SIGNAL	SIGNAL TITLE	EXPLANATION
DIS21_VTS_GrO_	Block from VTS	Blocking signal due to error in voltage measurement (Output of the user-defined graphic equation)
DIS21_SOTFCond_GrO_	SOTF COND.	Status signal indicating switching-onto-fault condition (Output of the user-defined graphic equation)

Table 1-3 Enumerated parameters for the impedance calculation

PARAMETER NAME	TITLE	SELECTION RANGE	DEFAULT
Parameters to select directionality of the individual zones:			
DIS21_Z1_EPar_	Operation Zone1	Off, Forward, Backward	Off
DIS21_Z2_EPar_	Operation Zone2	Off, Forward, Backward, NonDirectional	Off
DIS21_Z3_EPar_	Operation Zone3	Off, Forward, Backward, NonDirectional	Off

DIS21_Z4_EPar_	Operation Zone4	Off, Forward, Backward, NonDirectional	Off
DIS21_Z5_EPar_	Operation Zone5	Off, Forward, Backward, NonDirectional	Off
Parameter for selecting one of the zones or “high speed overcurrent protection” for the “switch-onto-fault” function:			
DIS21_SOTFMd_EPar_	SOTF Zone	Off, Zone1, Zone2, Zone3, Zone4, Zone5, HSOC	Zone1

Table 1-4 Floating point parameters for the impedance calculation

PARAMETER NAME	TITLE	DIM.	MIN	MAX	STEP	DEFAULT
DIS21_Z1aX_FPar_	Zone1 (Xo-X1)/3X1		0	5	0.01	1
DIS21_Z1aR_FPar_	Zone1 (Ro-R1)/3R1		0	5	0.01	1
DIS21_a2X_FPar_	Par.Line Xom/3X1		0	5	0.01	0
DIS21_a2R_FPar_	Par.Line Rom/3R1		0	5	0.01	0
DIS21_Z2aX_FPar_	Zone2 (Xo-X1)/3X1		0	5	0.01	1
DIS21_Z2aR_FPar_	Zone2 (Ro-R1)/3R1		0	5	0.01	1
DIS21_Z3aX_FPar_	Zone3 (Xo-X1)/3X1		0	5	0.01	1
DIS21_Z3aR_FPar_	Zone3 (Ro-R1)/3R1		0	5	0.01	1
DIS21_Z4aX_FPar_	Zone4 (Xo-X1)/3X1		0	5	0.01	1
DIS21_Z4aR_FPar_	Zone4 (Ro-R1)/3R1		0	5	0.01	1
DIS21_Z5aX_FPar_	Zone5 (Xo-X1)/3X1		0	5	0.01	1
DIS21_Z5aR_FPar_	Zone5 (Ro-R1)/3R1		0	5	0.01	1

The **outputs** are the calculated positive-sequence impedances (R+jX) of the six measuring current loops and, as different zero sequence current compensation factors can be set for the individual zones, the impedances are calculated for each zone separately:

- Impedances of the three phase-phase loops,
- Impedances of the three phase-ground loops.

Table 1-5 The measured (calculated) values of the Z_CALC module

MEASURED VALUE	DIM.	EXPLANATION
RL1+j XL1	ohm	Measured positive sequence impedance in the L1N loop, using the zero sequence current compensation factor for zone 1
RL2+j XL2	ohm	Measured positive sequence impedance in the L2N loop, using the zero sequence current compensation factor for zone 1
RL3+j XL3	ohm	Measured positive sequence impedance in the L3N loop, using the zero sequence current compensation factor for zone 1
RL1L2+j XL1L2	ohm	Measured positive sequence impedance in the L1L2 loop
RL2L3+j XL2L3	ohm	Measured positive sequence impedance in the L2L3 loop
RL3L1+j XL3L1	ohm	Measured positive sequence impedance in the L3L1 loop

Z_CALC includes six practically identical software modules for impedance calculation:

- The three routines of the phase group are activated by phase voltages, phase currents and the zero sequence current calculated from the phase current and the zero sequence currents of the parallel line, as measured in a dedicated input.
- The three routines for the phase-to-phase loops get line-to-line voltages calculated from the phase voltages and they get differences of the phase currents. They do not need zero sequence currents for the calculation.

The calculated impedances are analogue outputs of the distance protection function. They serve the purpose of checking possibility at commissioning.

	voltage phasor components for 35 ms period stored in the memory because the secondary swings of the capacitive voltage divider distort the sampled voltage values. This status signal is generated within the Z_CALC module.
MEM_AVAIL	This status signal is true if the voltage memory is filled up with available samples above the defined limit for 120 ms. This status signal is generated within the Z_CALC module.
HEALTHY_PHASE_AVAIL	This status signal is true if there are healthy phase voltages (in case of asymmetrical faults) that can be applied to directional decision. This status signal is generated within the Z_CALC module.
SOTF_COND	This status signal is true if the algorithm detected switch-onto-fault conditions, and the binary input signal DIS21_SOTFCond_GrO_ (SOTF COND.) is programmed by the user to logic "1", using the graphic equation editor.

The outputs of the scheme of [Figure 1-4](#) are calculation methods applied for impedance calculation for the individual zones.

Table 1-8 Calculation methods applied in the Z_CALC module

CALCULATION METHOD	EXPLANATION
Calc(A)	No current is available, the impedances are supposed to be higher than the possible maximum setting values $R=1000000 \text{ m}\Omega$, $X=1000000 \text{ m}\Omega$
Calc(B)	The currents and voltages are suitable for the correct impedance calculation and directional decision $R, X=f(u, i)$
Calc(C)	The currents are suitable, but the voltages are in the range of the CVT swings, so during the first 35 ms the directional decision is based on pre-fault voltages stored in the memory $R, X=f(u, i)$ direction = $f(U_{\text{mem}}, i)$ /in the first 35 ms/ $R, X=f(u, i)$ direction = $f(u, i)$ /after 35 ms/
Calc(D)	The currents are suitable, but the voltages are too low. The directional decision is based on pre-fault voltages stored in the memory $R, X=f(u, i)$ direction = $f(\max\{R(U_{\text{mem}}, i), X(U_{\text{mem}}, i)\})$
Calc(E)	The currents are suitable, but the voltages are in the range of the CVT swings and there are no healthy voltages stored in the memory but because of asymmetrical faults, there are healthy voltages. Therefore, during the first 35 ms the directional decision is based on healthy voltages $R, X=f(u, i)$ direction = $f(U_{\text{healthy}}, i)$ /in the first 35 ms/ $R, X=f(u, i)$ direction = $f(u, i)$ /after 35 ms/
Calc(F)	The currents are suitable, but the voltages are too low, there are no pre-fault voltages stored in the memory but because of asymmetrical faults, there are healthy voltages. Therefore, the directional decision is based on healthy voltages $R, X=f(u, i)$ direction = $f(U_{\text{healthy}}, i)$
Calc(G)	If no directional decision is required or in case of prescribed SOTF logic the fault was caused by a switching, then the decision is based on the absolute value of the impedance (forward fault is supposed) $R=\text{abs}(R)$, $X=\text{abs}(X)$
Calc(H)	If the decision is not possible (no voltage, no pre-fault voltage, no healthy phase voltage but directional decision is required), then the impedance is set to a value above the possible impedance setting $R=1000500 \text{ m}\Omega$, $X=1000500 \text{ m}\Omega$

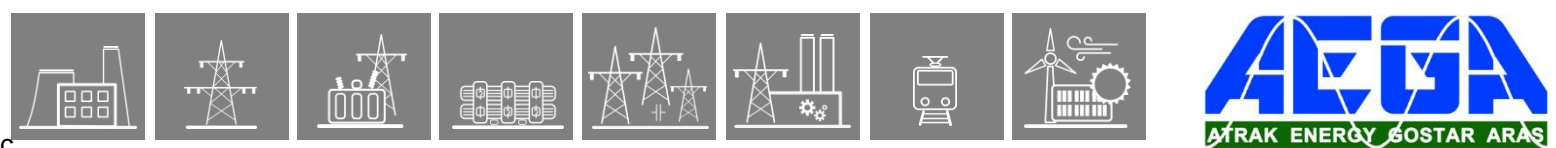

4.1.1.1.2.5. The impedance calculation methods

The short explanation of the internal logic for the impedance calculation is as follows:

Calculation method Calc(A):

If the CURRENT_OK status signal is false, the current is very small, therefore no fault is possible. In this case, the impedance is set to extreme high values and no further calculation is performed:

$$R=1000000, X=1000000.$$

The subsequent decisions are performed if the current is sufficient for the calculation.

Calculation method Calc(B):

If the CURRENT_OK status signal is true and the VOLT_OK_HIGH status signal is true as well, then the current is suitable for calculation and the voltage is sufficient for the directionality decision. In this case, normal impedance calculation is performed based on the currents and voltages. (The calculation method - the function "F" - is explained later.)

$$R, X=f(u, i)$$

Calculation method Calc(C):

If the CURRENT_OK status signal is true but the VOLT_OK_HIGH status signal is false or there are voltage swings, the directionality decision cannot be performed based on the available voltage signals temporarily. In this case, if the voltage is above a minimal level (in the range of possible capacitive voltage transformer swings), then the VOLT_OK_LOW status is "true", the magnitude of R and X is calculated based on the actual currents and voltages but the direction of the fault (the +/- sign of R and X) must be decided based on the voltage value stored in the memory 120 ms earlier. (The high voltage level setting assures that during the secondary swings of the voltage transformers, no distorted signals are applied for the decision). This procedure is possible only if there are stored values in the memory for 120 ms and these values were sampled during a healthy period.

$$R, X=f(u, i) \quad \text{direction} = f(U_{\text{mem}}, i) \text{ /in the first 35 ms/}$$

After 35 ms (when the secondary swings of the voltage transformers decayed), the directional decision returns to the measured voltage signal again:

$$R, X=f(u, i) \quad \text{direction} = f(u, i) \text{ /after 35 ms/}$$

Calculation method Calc(D):

If the voltage is below the minimal level, then the VOLT_OK_LOW status is "false" but if there are voltage samples stored in the memory for 120 ms, then the direction is decided based on the sign either of the real part of the impedance or that of the imaginary part of the impedance, whichever is higher.

$$R, X=f(u, i) \quad \text{direction} = f(\max\{R(U_{\text{mem}}, i), X(U_{\text{mem}}, i)\})$$

Calculation method Calc(E):

The currents are suitable, but the voltages are in the range of the CVT swings, there are no pre-fault voltages stored in the memory but because of asymmetrical faults, there are healthy phase voltages. Therefore, during the first 35 ms the directional decision is based on healthy voltages

$$R, X=f(u, i) \quad \text{direction} = f(U_{\text{healthy}}, i) \text{ /in the first 35 ms/}$$

$$R, X=f(u, i) \quad \text{direction} = f(u, i) \text{ /after 35 ms/}$$

The positive and negative sequence components of the voltage and current system are composed and used to determine the direction of the fault.



Calculation method Calc(F):

The currents are suitable, but the voltages are too low, there are no pre-fault voltages stored in the memory but because of asymmetrical faults, there are healthy voltages. Therefore, the directional decision is based on healthy voltages

$$R, X=f(u, i) \quad \text{direction} = f(U_{\text{healthy}}, i)$$

The directional decision is described in calculation method Calc(E).

Calculation method Calc(G):

If no directional decision is required or in case of prescribed SOTF logic and the fault was caused by a switching, then the decision is based on the absolute value of the impedance (forward fault is supposed)

$$R=\text{abs}(R), \quad X=\text{abs}(X)$$

Calculation method Calc(H):

If the voltage is not sufficient for a directional decision and no stored voltage samples are available, and if the “switch-onto-fault” logic is not enabled, then the impedance is set to a high value:

$$R=1000500 \text{ m}\Omega, \quad X=1000500 \text{ m}\Omega$$

4.1.1.1.3. The polygon characteristics (POLY)

4.1.1.1.3.1. Impedance characteristics of the distance protection

The calculated R_1 and $X_1 = \omega L_1$ co-ordinate values define six points on the complex impedance plane for the six possible measuring loops. These impedances are the positive sequence impedances. The protection compares these points with the „polygon” characteristics of the distance protection, shown in [Figure 1-5](#). The main setting values of R and X refer to the positive sequence impedance of the fault loop, including the positive sequence fault resistance of the possible electric arc and, in case of a ground fault, the positive sequence resistance of the tower grounding as well. (When testing the device using a network simulator, the resistance of the fault location is to be applied to match the positive sequence setting values of the characteristic lines.)

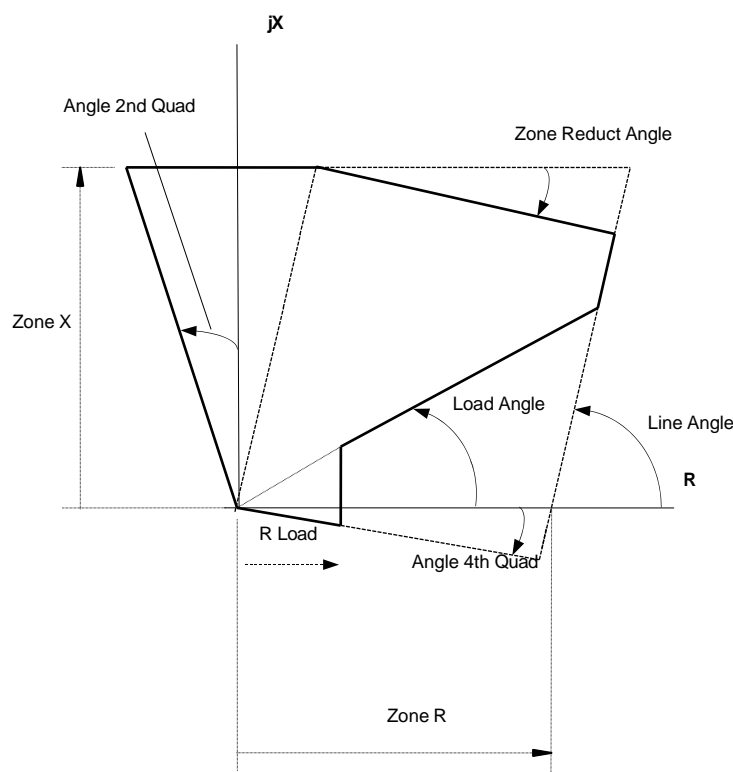

Figure 1-5 The polygon characteristics of the distance protection function on the complex plane

If a measured impedance point is inside the polygon, the algorithm generates the true value of the related output binary signal.

The calculated impedance values are compared one by one with the setting values of the polygon characteristics. This procedure is shown schematically in [Figure 1-6](#).

The procedure is processed for each line-to-ground loop and for each line-to-line loop. Then this is repeated for all five impedance stages. The result is the setting of 6 x 5 status variables, which indicate that the calculated impedance is within the processed polygon, meaning that the impedance stage has started.

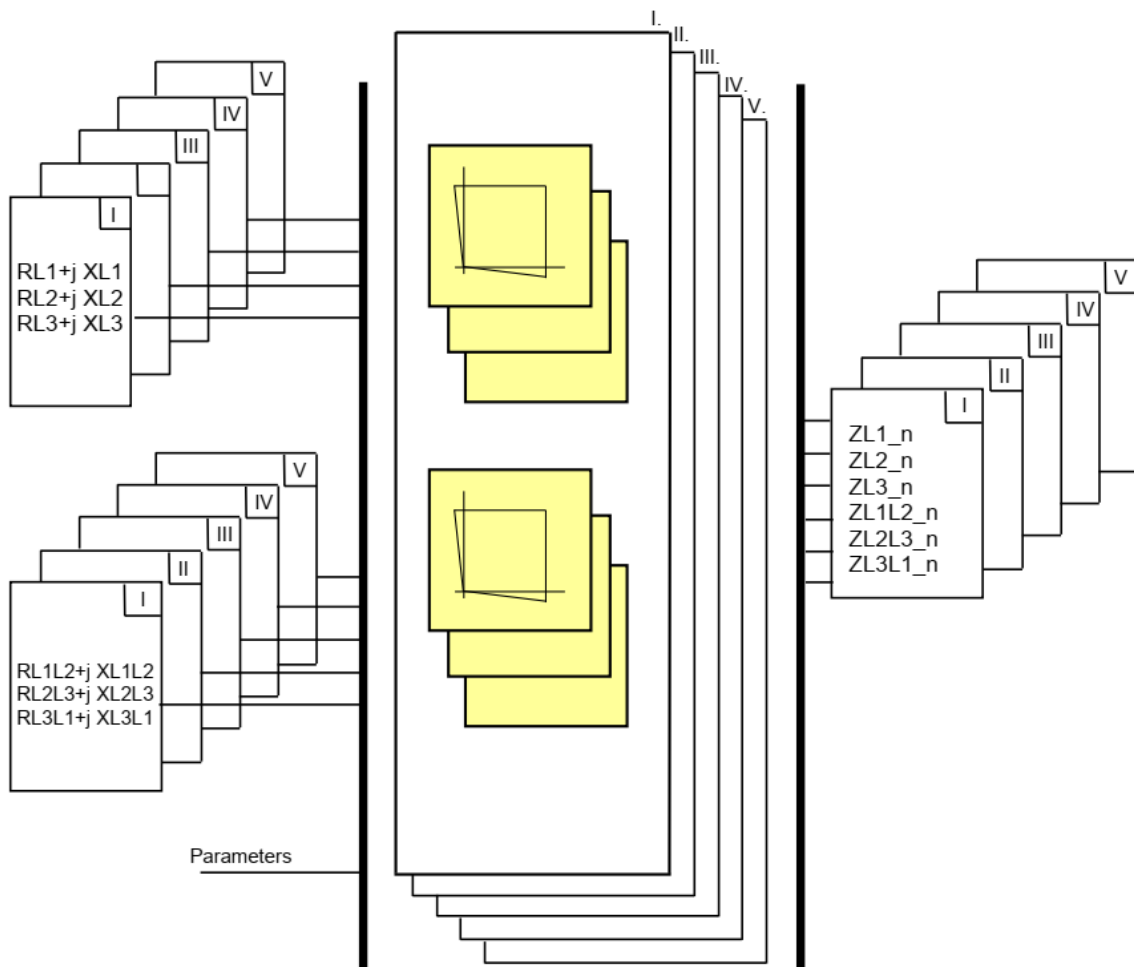

Figure 1-6 POLY logic

Input values

The input values are calculated by the module Z_CALC.

Table 1-9 The input impedances of the POLY module

INPUT VALUES	ZONES	EXPLANATION
RL1+j XL1	1...5	Calculated impedance in the fault loop L1N using parameters of the zones individually
RL2+j XL2	1...5	Calculated impedance in the fault loop L2N using parameters of the zones individually
RL3+j XL3	1...5	Calculated impedance in the fault loop L3N using parameters of the zones individually
RL1L2+j XL1L2	1...5	Calculated impedance in the fault loop L1L2 using parameters of the zones individually
RL2L3+j XL2L3	1...5	Calculated impedance in the fault loop L2L3 using parameters of the zones individually
RL3L1+j XL3L1	1...5	Calculated impedance in the fault loop L3L1 using parameters of the zones individually

4.1.1.1.4. The phase selection logic (SELECT) and timing

In case of faults, the calculated impedance value for the faulty loop is inside a polygon. If the fault is near the relay location, the impedances in the loop containing the faulty phase can also be inside the polygon. To ensure selective tripping, phase selection is needed. This chapter explains the operation of the phase selection logic.

The **binary inputs** are signals influencing the operation of the distance protection function. These signals are the results of logic equations graphically edited by the user.

Table 1-14 Binary input signals influencing the phase selection logic

BINARY INPUT SIGNALS	SIGNAL TITLE	EXPLANATION
DIS21_Z1Blk_GrO_	Block Z1	Blocking of Zone 1
DIS21_Z2Blk_GrO_	Block Z2	Blocking of Zone 2
DIS21_Z3Blk_GrO_	Block Z3	Blocking of Zone 3
DIS21_Z4Blk_GrO_	Block Z4	Blocking of Zone 4
DIS21_Z5Blk_GrO_	Block Z5	Blocking of Zone 5
DIS21_SOTFCond_GrO_	SOTF COND.	Status signal indicating switching-onto-fault condition

Table 1-15 Binary input signals from the POLY logic

BINARY INPUT SIGNALS	EXPLANATION
ZL1_n	Calculated impedance for loop L1 is inside the polygon of Zone "n" (n=1...5)
ZL2_n	Calculated impedance for loop L2 is inside the polygon of Zone "n" (n=1...5)
ZL3_n	Calculated impedance for loop L3 is inside the polygon of Zone "n" (n=1...5)
ZL1L2_n	Calculated impedance for loop L1L2 is inside the polygon of Zone "n" (n=1...5)
ZL2L3_n	Calculated impedance for loop L2L3 is inside the polygon of Zone "n" (n=1...5)
ZL3L1_n	Calculated impedance for loop L3L1 is inside the polygon of Zone "n" (n=1...5)

Table 1-16 Binary output of the phase selection logic

BINARY OUTPUT SIGNALS	SIGNAL TITLE	EXPLANATION
Distance Zone 1		
DIS21_Z1St_Grl_	Start Z1	General start of Zone1
DIS21_Z1StL1_Grl_	Z1 Start L1	Start in phase L1 of Zone1
DIS21_Z1StL2_Grl_	Z1 Start L2	Start in phase L2 of Zone1
DIS21_Z1StL3_Grl_	Z1 Start L3	Start in phase L3 of Zone1
DIS21_Z1Tr_Grl_	Trip Z1	Trip command generated in Zone1
Distance Zone 2 similar to Zone 1		
Distance Zone 3 similar to Zone 1		
Distance Zone 4 similar to Zone 1		
Distance Zone 5 similar to Zone 1		

Table 1-17 Enumerated parameters of the distance protection function

PARAMETER NAME	TITLE	SELECTION RANGE	DEFAULT
Parameters to select directionality of the individual zones:			
DIS21_Z1_EPar_	Operation Zone1	Off, Forward, Backward	Off
DIS21_Z2_EPar_	Operation Zone2	Off, Forward, Backward, NonDirectional	Off
DIS21_Z3_EPar_	Operation Zone3	Off, Forward, Backward, NonDirectional	Off
DIS21_Z4_EPar_	Operation Zone4	Off, Forward, Backward, NonDirectional	Off
DIS21_Z5_EPar_	Operation Zone5	Off, Forward, Backward, NonDirectional	Off

Table 1-18 Boolean parameters of the phase selection logic

PARAMETER NAME	TITLE	DEFAULT	EXPLANATION
DIS21_Z1St_BPar_	Zone1 Start Only	0	0 for Zone1 to generate trip command
DIS21_Z2St_BPar_	Zone2 Start Only	0	0 for Zone2 to generate trip command
DIS21_Z3St_BPar_	Zone3 Start Only	0	0 for Zone3 to generate trip command
DIS21_Z4St_BPar_	Zone4 Start Only	0	0 for Zone4 to generate trip command
DIS21_Z5St_BPar_	Zone5 Start Only	0	0 for Zone5 to generate trip command

Table 1-19 Timer parameters of the distance protection function

PARAMETER NAME	TITLE	UNIT	MIN	MAX	STEP	DEFAULT
Time delay for the zones individually						
DIS21_Z1Del_TPar_	Zone1 Time Delay	ms	0	60000	1	0
DIS21_Z2Del_TPar_	Zone2 Time Delay	ms	40	60000	1	400
DIS21_Z3Del_TPar_	Zone3 Time Delay	ms	40	60000	1	800
DIS21_Z4Del_TPar_	Zone4 Time Delay	ms	40	60000	1	2000
DIS21_Z5Del_TPar_	Zone5 Time Delay	ms	40	60000	1	2000



Zone1 timer starts at the rising edge of its start signal, whereas the timer of the other zones contains the time of the detection algorithm as well, therefore their minimum value is 40 ms.

4.1.1.1.4.1. Three-phase fault detection

The processing of diagrams in the following figures is sequential. If the result of one of them is true, no further processing is performed.

Figure 1-7 shows that if

- all three line-line loops of the polygon impedance logic have stated and
- the currents in all three phases are above the setting limit,

then a three-phase fault is detected, and no further check is performed. The three-phase fault detection resets only if none of the three line-to-line loops detect fault any longer.

In Figure 1-7 and in the subsequent figures “n = 1..5” means that the logic is repeated for all five zones.

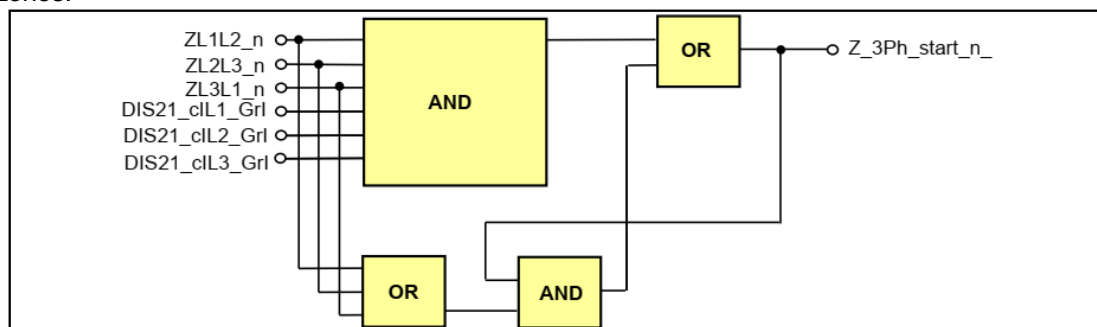

Figure 1-7 Three-phase fault detection in Zone “n” (n=1..5)

Table 1-20 Three-phase start of the distance protection function

OUTPUT STATUS SIGNALS	ZONES	EXPLANATION
Z_3Ph_start_n	n=1..5	Three-phase start of the distance protection function in zone “n”

Table 1-21 Inputs needed to decide the three-phase start of the function

INPUT STATUS SIGNALS	ZONES	EXPLANATION
ZL1L2_n	n=1...5	The calculated impedance of fault loop L1L2 is within the zone characteristic
ZL2L3_n	n=1...5	The calculated impedance of fault loop L2L3 is within the zone characteristic
ZL3L1_n	n=1...5	The calculated impedance of fault loop L3L1 is within the zone characteristic
DIS21_cIL1_Grl	n=1...5	The current in phase L1 is sufficient for impedance calculation
DIS21_cIL2_Grl	n=1...5	The current in phase L2 is sufficient for impedance calculation
DIS21_cIL3_Grl	n=1...5	The current in phase L3 is sufficient for impedance calculation

4.1.1.1.4.2. Detection of “L1L2”, “L2L3”, “L3L1” faults

Figure 1-8 explains the detection of a phase-to-phase fault between phases “L1” and “L2”:

- no fault is detected in the previous sequential tests,
- the start of the polygon impedance logic in loop “L1L2” and loop “L1L2” detects the lowest reactance, and
- “OR” relation of the following logic states:
 - no zero sequence current above the limit and no start of the polygon logic in another phase-to-phase loop, or
 - in the presence of a zero sequence current
 - start of the polygon impedance logic in loops “L1” and “L2” individually as well, or
 - the voltage is small in the faulty “L1L2” loop and the currents in both phases involved are above the setting limit.

The “L1L2” fault detection resets only if none of the “L1L2” line-to-line, “L1N” or “L2N” loops detect fault any longer.

In Figures Figure 1-8, Figure 1-9 and Figure 1-10:

$$\text{minLL} = \text{Minimum}(ZL1L2, ZL2L3, ZL3L1)$$

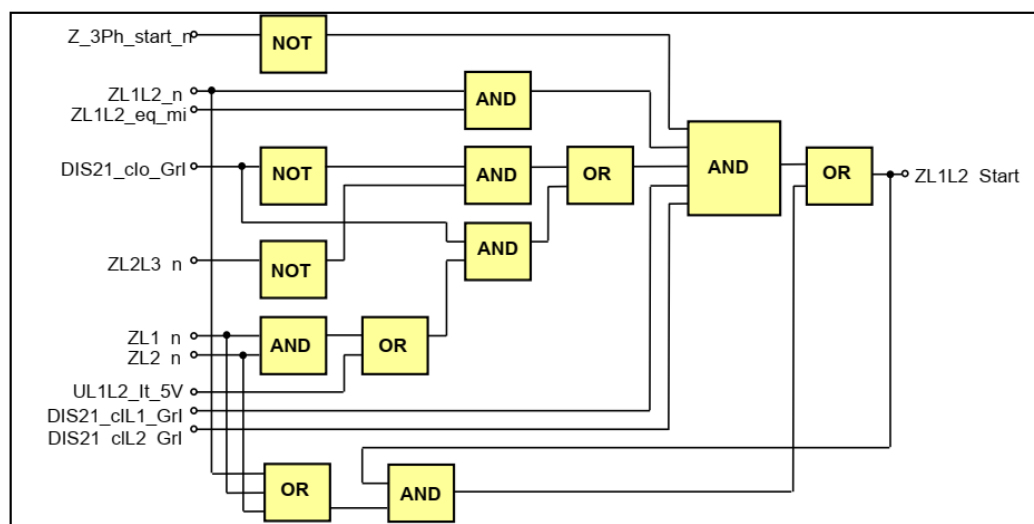

Figure 1-8 L1L2 fault detection in Zone “n” (n=1..5)

Figure 1-9 and Figure 1-10 show a similar logic for loops “L2L3” and “L3L1”, respectively.

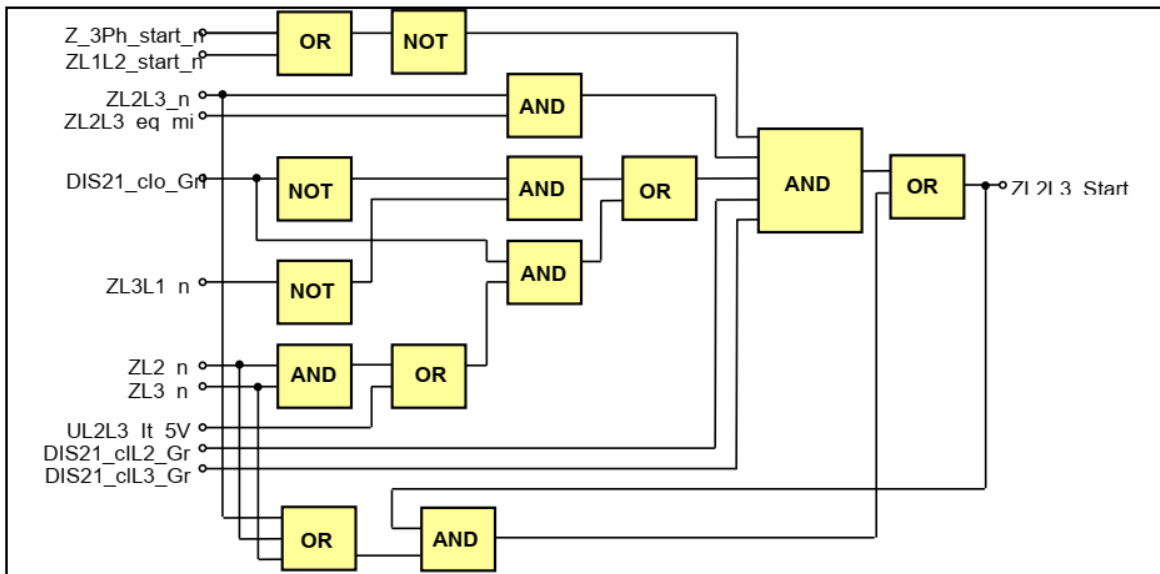

Figure 1-9 L2L3 fault detection in Zone “n” (n=1..5)

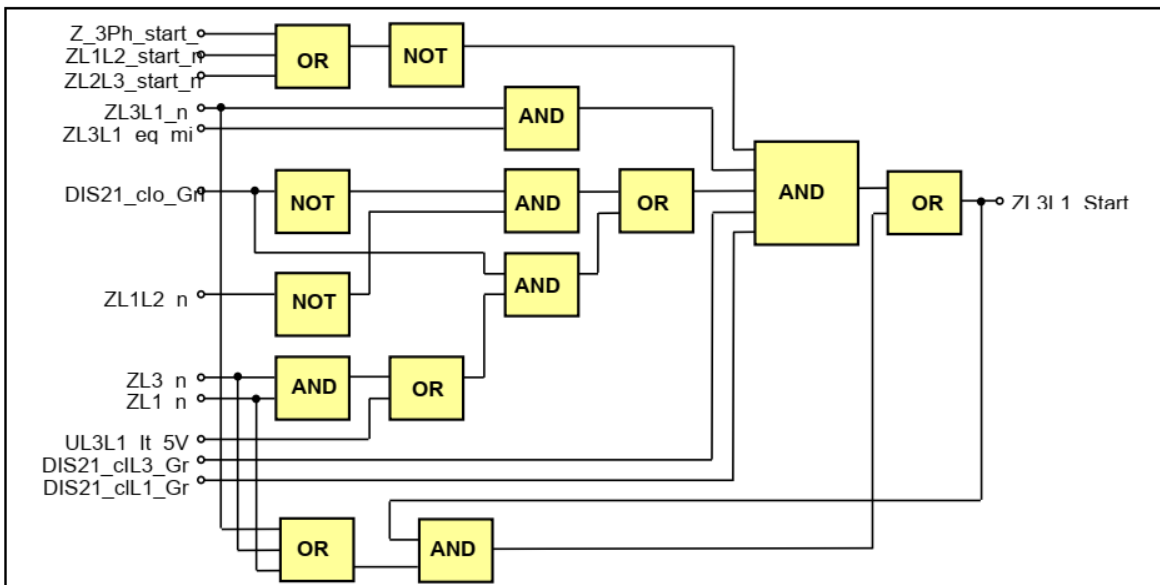

Figure 1-10 L3L1 fault detection in Zone “n” (n=1..5)

Table 1-22 Phase-to-phase loop start of the distance protection function

OUTPUT STATUS SIGNALS	ZONES	EXPLANATION
L1L2_Start_n	n=1..5	L1L2 loop start of the distance protection function in zone “n”
L2L3_Start_n	n=1..5	L2L3 loop start of the distance protection function in zone “n”
L3L1_Start_n	n=1..5	L3L1 loop start of the distance protection function in zone “n”

Table 1-23 Inputs needed to decide phase-to-phase loop start of the distance protection function

INPUT STATUS SIGNALS	ZONES	EXPLANATION
Z_3Ph_start_n	n=1...5	Outputs of the previous decisions
ZL1L2_Start_n	n=1...5	Outputs of the previous decisions
ZL2L3_Start_n	n=1...5	Outputs of the previous decisions
ZL1L2_n	n=1...5	The calculated impedance of fault loop L1L2 is within the zone characteristic
ZL2L3_n	n=1...5	The calculated impedance of fault loop L2L3 is within the zone characteristic
ZL3L1_n	n=1...5	The calculated impedance of fault loop L3L1 is within the zone characteristic
ZL1L2_equ_minLL	n=1...5	The calculated impedance of fault loop L1L2 is the smallest one
ZL2L3_equ_minLL	n=1...5	The calculated impedance of fault loop L2L3 is the smallest one
ZL3L1_equ_minLL	n=1...5	The calculated impedance of fault loop L3L1 is the smallest one
ZL1_n	n=1...5	The calculated impedance of fault loop L1N is within the zone characteristic
ZL2_n	n=1...5	The calculated impedance of fault loop L2N is within the zone characteristic
ZL3_n	n=1...5	The calculated impedance of fault loop L3N is within the zone characteristic
DIS21_cIL1_Grl		The current in phase L1 is sufficient for impedance calculation
DIS21_cIL2_Grl		The current in phase L2 is sufficient for impedance calculation
DIS21_cIL3_Grl		The current in phase L3 is sufficient for impedance calculation
DIS21_cIo_Grl_		The zero sequent current component is sufficient for earth fault calculation
UL1L2_Lt_5V		The L1L2 voltage is less than 5V
UL3L3_Lt_5V		The L2L3 voltage is less than 5V
UL3L2_Lt_5V		The L3L1 voltage is less than 5V

4.1.1.1.4.3. Detection of “L1N”, “L2N”, “L3N” faults

Figure 1-11 explains the detection of a phase-to-ground fault in phase “L1”:

- no fault is detected in the previous sequential tests,
- start of the polygon impedance logic in loop “L1N”,
- the minimal impedance is measured in loop “L1N”,
- no start of the polygon logic in another phase-to-ground loop,
- the zero sequence current above the limit,
- the current in the phase involved is above the setting limit,
- the minimal impedance of the phase-to-ground loops is less then the minimal impedance in the phase-to-phase loops.

In Figure 1-11, Figure 1-12 and Figure 1-13:

$$\text{minLN} = \text{Minimum}(ZL1N, ZL2N, ZL3N)$$

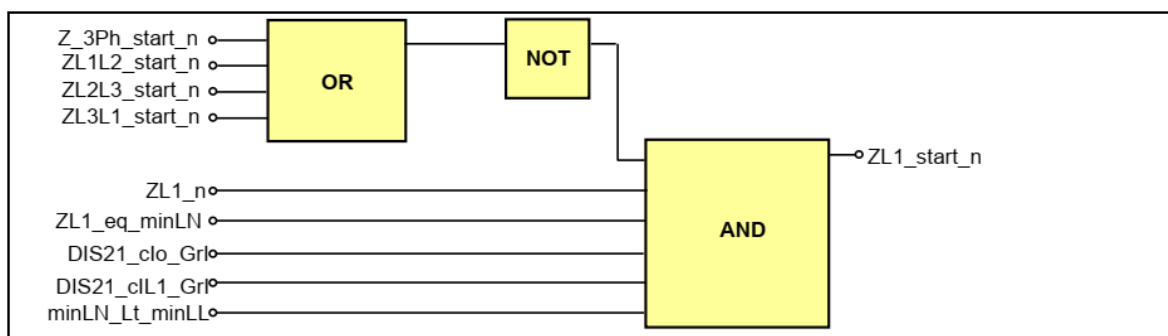

Figure 1-11 L1N fault detection in Zone “n” (n=1..5)

Figure 1-12 and Figure 1-13 show similar logic for loops “L2” and “L3” respectively.

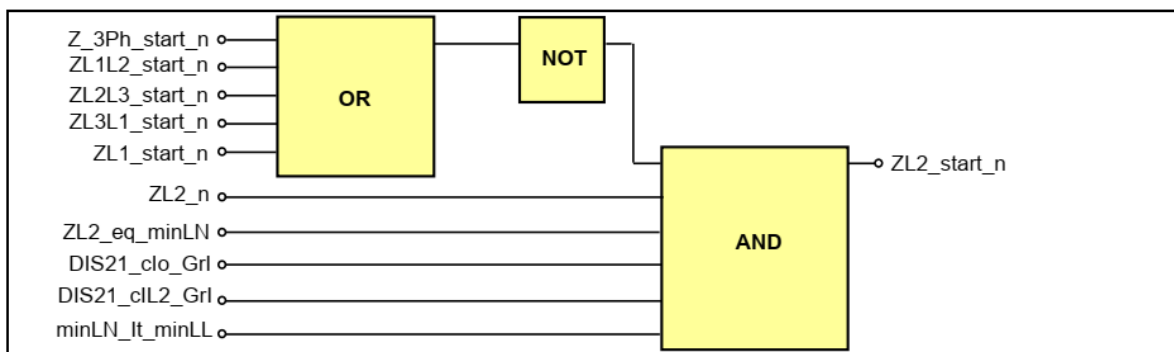

Figure 1-12 L2N fault detection in Zone “n” (n=1..5)

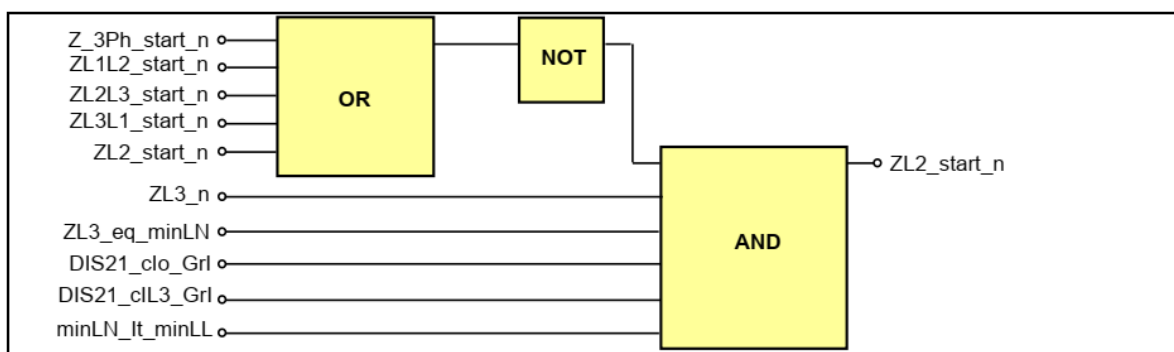

Figure 1-13 L3N fault detection in Zone “n” (n=1..5)

Table 1-24 Phase-to-ground loop start of the distance protection function

OUTPUT STATUS SIGNALS	ZONES	EXPLANATION
ZL1_Start_n	n=1...5	L1N loop start of the distance protection function in zone "n"
ZL2_Start_n	n=1...5	L2N loop start of the distance protection function in zone "n"
ZL3_Start_n	n=1...5	L3N loop start of the distance protection function in zone "n"

Table 1-25 Inputs needed to decide Phase-to-ground loop start of the distance protection function

INPUT STATUS SIGNALS	ZONES	EXPLANATION
ZL1L2_Start_n	n=1...5	Outputs of the previous decisions
ZL2L3_Start_n	n=1...5	Outputs of the previous decisions
ZL3L1_Start_n	n=1...5	Outputs of the previous decisions
ZL1_Start_n	n=1...5	Outputs of the previous decisions
ZL2_Start_n	n=1...5	Outputs of the previous decisions
ZL1_equ_minLN	n=1...5	The calculated impedance of fault loop L1 is the smallest one
ZL2_equ_minLN	n=1...5	The calculated impedance of fault loop L2 is the smallest one
ZL3_equ_minLN	n=1...5	The calculated impedance of fault loop L3 is the smallest one
ZL1_n	n=1...5	The calculated impedance of fault loop L1N is within the zone characteristic
ZL2_n	n=1...5	The calculated impedance of fault loop L2N is within the zone characteristic
ZL3_n	n=1...5	The calculated impedance of fault loop L3N is within the zone characteristic
DIS21_cIL1_Grl	n=1...5	The current in phase L1 is sufficient for impedance calculation
DIS21_cIL2_Grl	n=1...5	The current in phase L2 is sufficient for impedance calculation
DIS21_cIL3_Grl	n=1...5	The current in phase L3 is sufficient for impedance calculation
DIS21_cIo_Grl	n=1...5	The zero sequence current component is sufficient for impedance calculation in LN loops

Figure 1-14 shows how the signals are processed for the output signals of the distance protection function.

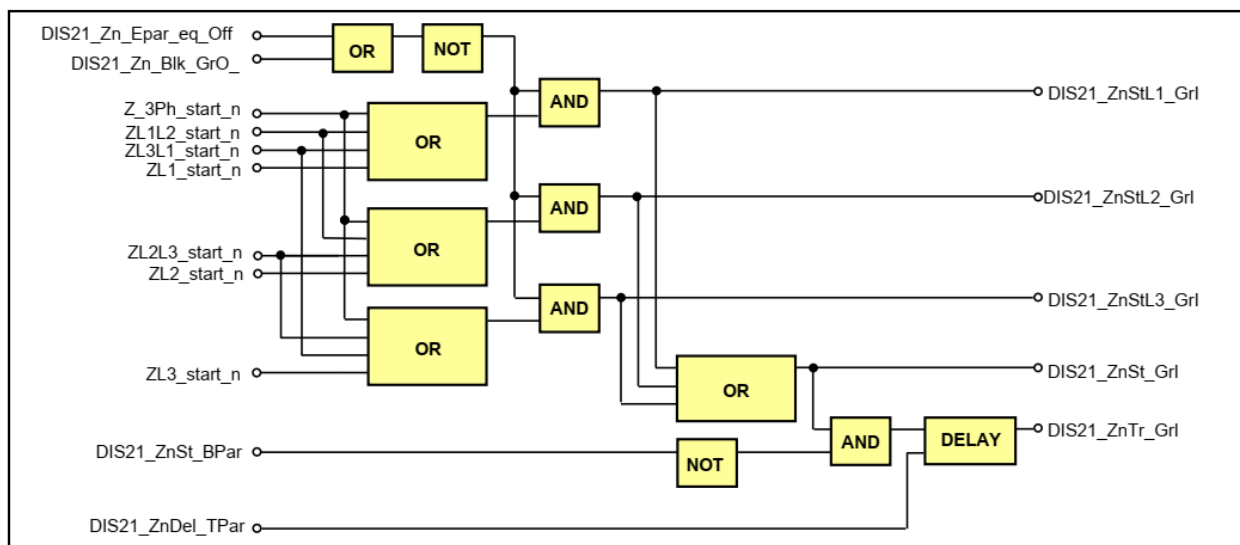

Figure 1-14 L3N fault detection in Zone "n" (n=1..5)

- The operation of the distance protection may be blocked either by parameter setting (DIS21_Zn_EPar_eq_Off) or by binary input (DIS21_Zn_BlK_GrO_)
- Starting in phase L1 if this phase is involved in the fault (DIS21_ZnStL1_GrI),
- Starting in phase L2 if this phase is involved in the fault (DIS21_ZnStL2_GrI),
- Starting in phase L3 if this phase is involved in the fault (DIS21_ZnStL3_GrI),
- General start if any of the phases is involved in the fault (DIS21_ZnSt_GrI),
- A trip command (DIS21_ZnTr_GrI) is generated after the timer Zn_Delay has expired. This timer is started if the zone is started and it is not assigned to “Start signal only”, using the parameter DIS21_ZnSt_BPar. The time delay is set by the timer parameter DIS21_ZnDel_TPar.

Figure 1-15 shows the method of post-processing the binary output signals to generate general start signals for the phases individually and separately for zones 2 to 5.

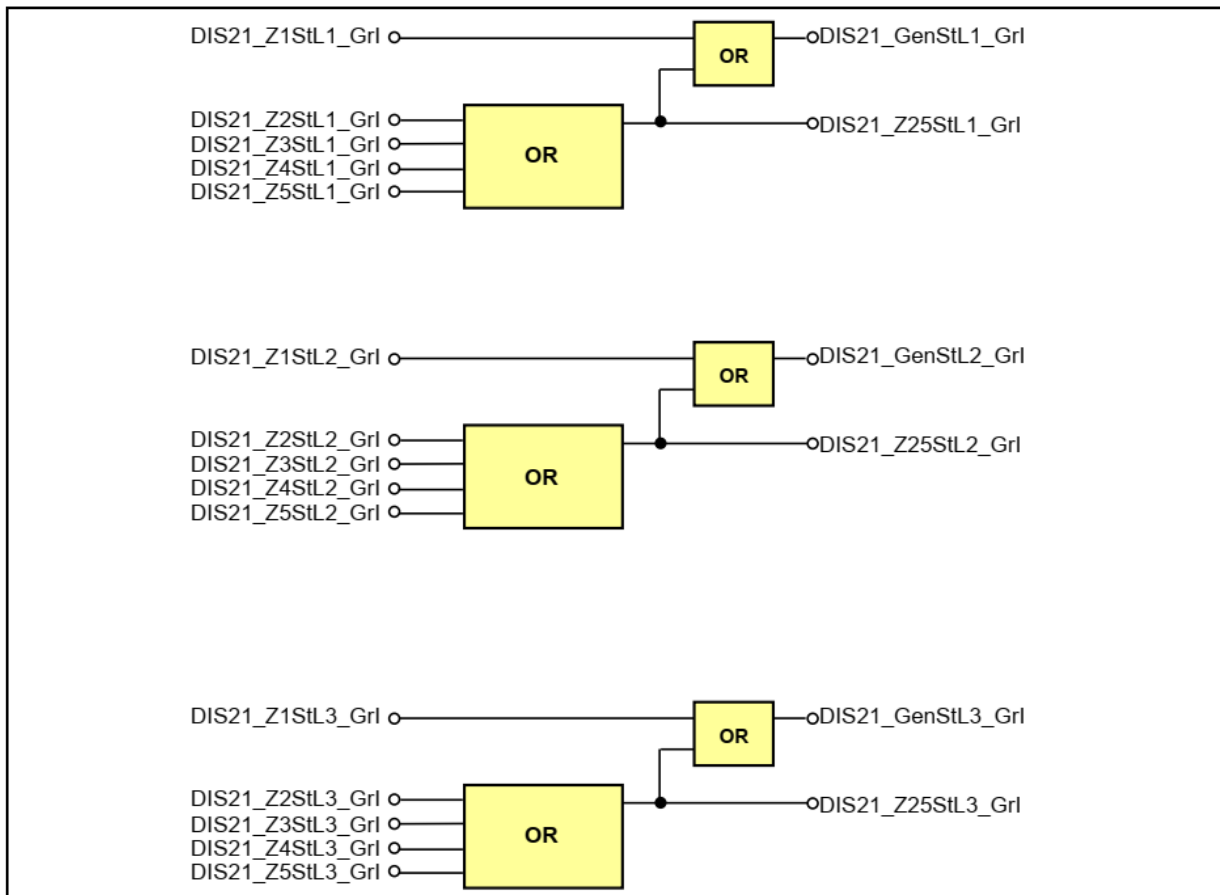

Figure 1-15 General start in the phase-to-ground loops separately for Zones 2-to 5

The **binary output status signals** of the distance protection function.

Table 1-26 General phase identification of the distance protection function

BINARY OUTPUT SIGNALS	SIGNAL TITLE	EXPLANATION
Distance Phase identification		
DIS21_GenStL1_GrI_	GenStart L1	General start in phase L1
DIS21_GenStL2_GrI_	GenStart L2	General start in phase L2
DIS21_GenStL3_GrI_	GenStart L3	General start in phase L3

The separate phase identification signals for Zones 2-5 are not published.

4.1.1.1.5. The current condition of the distance protection function (I_COND)

The distance protection function can operate only if the current is sufficient for impedance calculation. Additionally, a phase-to-ground fault is detected only if there is sufficient zero sequence current. This function performs these preliminary decisions.

Table 1-27 The binary output status signals of the current conditions module

BINARY OUTPUT SIGNALS	SIGNAL TITLE	EXPLANATION
Distance function start conditions generated by the I_COND module (these signals are not published)		
DIS21_clo_Grl_	Io condition	The zero sequent current component is sufficient for earth fault calculation
DIS21_cIL1_Grl_	I L1 condition	The current in phase L1 is sufficient for impedance calculation
DIS21_cIL2_Grl_	I L2 condition	The current in phase L2 is sufficient for impedance calculation
DIS21_cIL3_Grl_	I L3 condition	The current in phase L3 is sufficient for impedance calculation

Table 1-28 Integer parameters for the current conditions module

PARAMETER NAME	TITLE	UNIT	MIN	MAX	STEP	DEFAULT
Definition of minimal current enabling impedance calculation:						
DIS21_lmin_IPar_	I Ph Base Sens	%	10	30	1	20
Definition of zero sequence current characteristic enabling impedance calculation in phase-to-earth loops:						
DIS21_IoBase_IPar_	I Res Base Sens	%	10	50	1	10
DIS21_IoBias_IPar_	I Res Bias	%	5	30	1	10

The current is considered to be sufficient for impedance calculation if it is above the level set by parameter **I Ph Base Sens**.

To decide the presence or absence of the zero sequence current, biased characteristics are applied (see Figure 1-16). The minimal setting current **I Res Base Sens** and a percentage biasing **I Res Bias** must be set. The biasing is applied for the detection of zero sequence current in the case of increased phase currents.

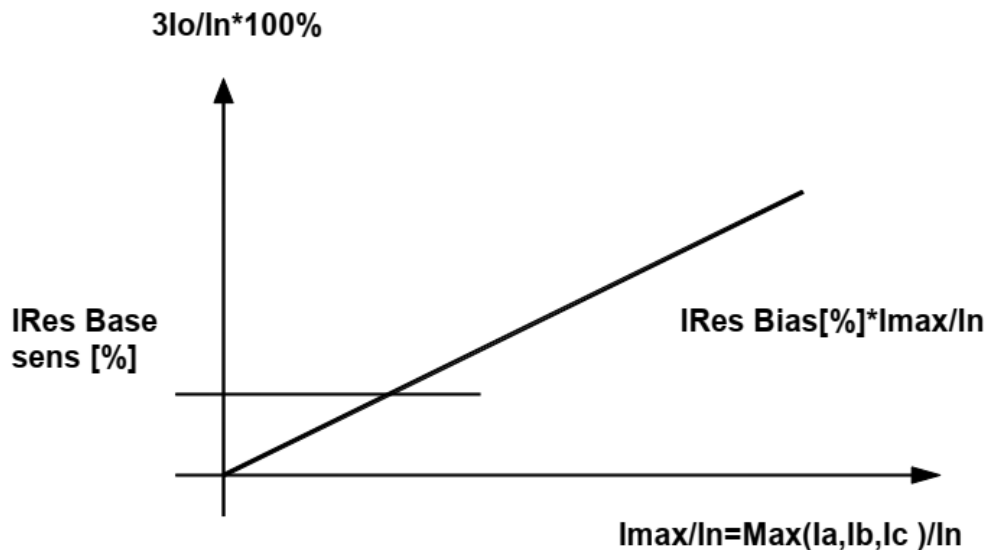
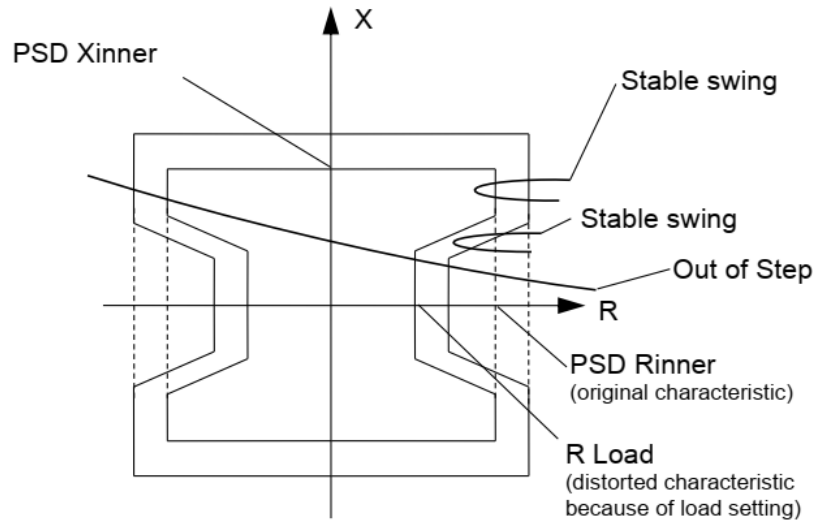

Figure 1-16 Percentage characteristic for earth-fault detection

4.1.1.1.6. The power swing detection (PSD)

Power swings can be stable, or they can result in an out-of-step operation. Accordingly, the power swing detection function can block the distance protection function in case of stable swings, or it can generate a trip command if the system operates out of step (see Figure 1-17).

The characteristics are affected by the load encroachment settings: if the load setting (**R Load**) is lower than the setting of the inner rectangle, then the rectangle will be distorted according to the encroachment characteristic. According to this, the outer rectangle will be modified as well.



Ratio of the outer characteristics set by:

PSD R_{out}/R_{in}

PSD X_{out}/X_{in}

Figure 1-17 Characteristics of the power swing detection function

Table 1-29 The binary output status signals of the power swing detection function

BINARY OUTPUT SIGNALS	SIGNAL TITLE	EXPLANATION
Distance function power swing signals generated by the PSD module		
DIS21_PSDDet_Grl_	PSD Detect	Signal for power swing detection
DIS21_OutTr_Grl_	OutOfStep Trip	Signal for out-of-step tripping condition
DIS21_PSDslow_Grl_	VerySlow Swing	Signal for very slow power swing detection

All these binary signals can serve as binary inputs for the graphic equations, to be programmed by the user.

The **binary inputs** are signals influencing the operation of the distance protection function. These signals are the results of logic equations graphically edited by the user. E.g., the DIS21_PSDBlk_GrO_ signal can be programmed using these inputs to block the power swing detection.

Table 1-30 The binary input signals of the power swing detection function

BINARY INPUT SIGNALS	SIGNAL TITLE	EXPLANATION
DIS21_PSDBlk_GrO_	Block PSD	Blocking signal for power swing detection

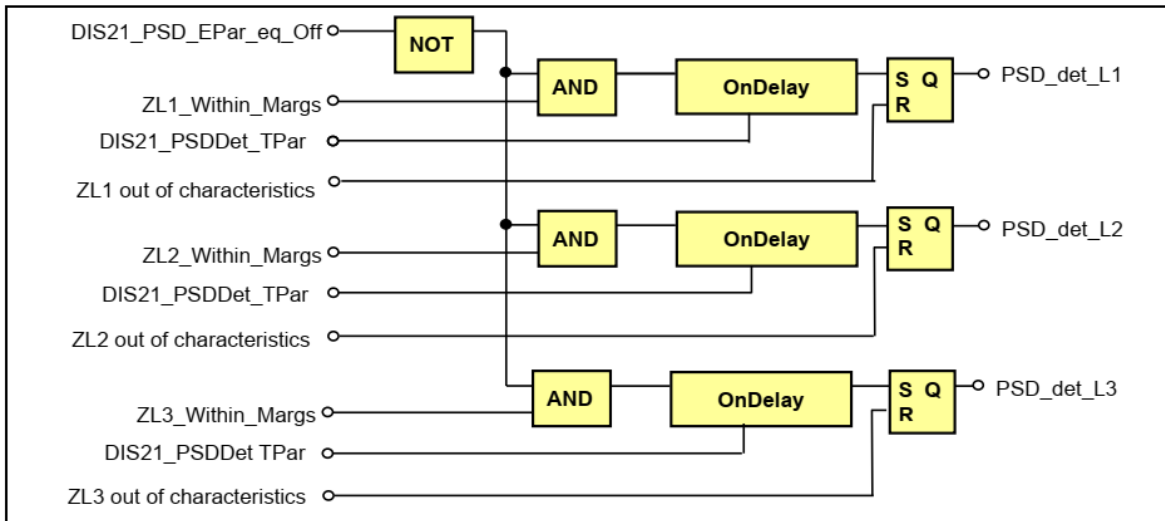

Figure 1-18 Power swing detection in the individual phases

Figure 1-18 shows that power swing is detected in the individual phases if the measured impedance (Phase-to-ground loop for Zone1) is within the margins of the PSD characteristics for the time span, given with parameter **PSD Time Delay**.

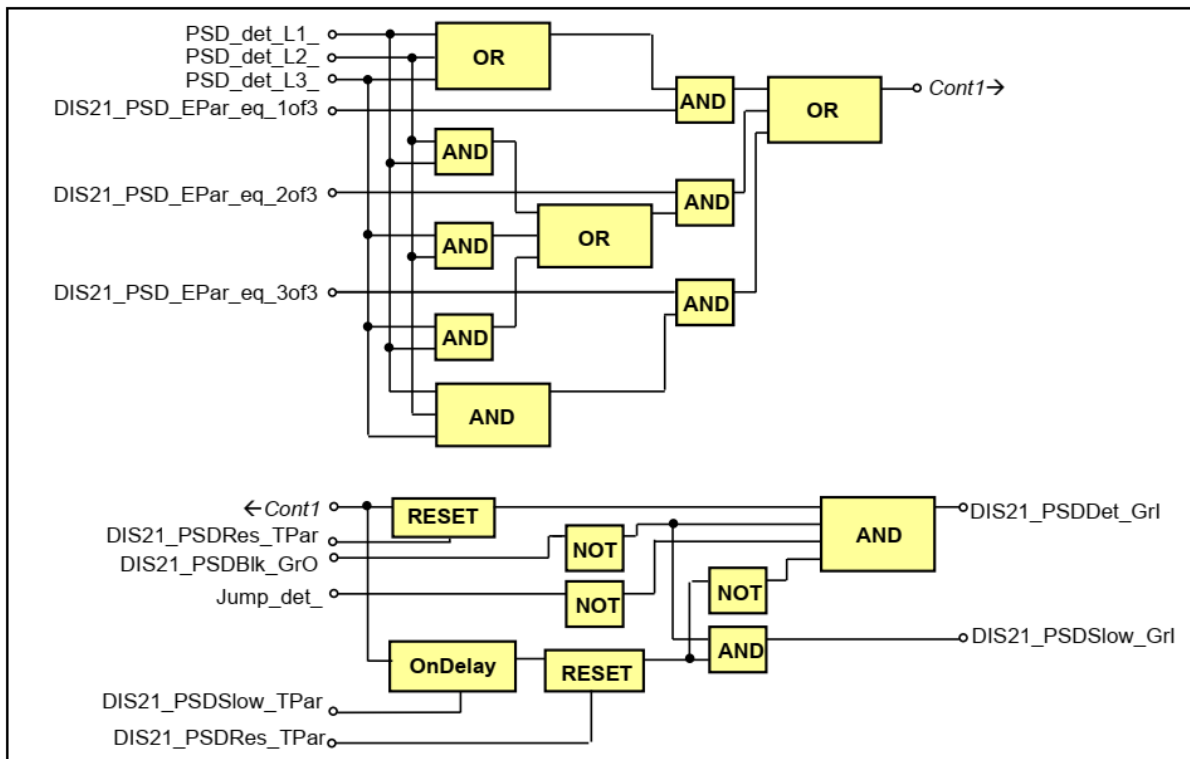

Figure 1-19 Power swing detection and slow power swing detection

According to Figure 1-19, the power swings in the individual phases result in a power swing state only if the combination of the phases corresponds to the parameter setting **Operation PSD** (which can be 1 out of 3, 2 out of 3, 3 out of 3).

The function can be blocked using the enumerated parameter **Operation PSD** if it is set to “Off”. The function can be blocked using the user-programmable graphic output status DIS21_PSDBlk_GrO_.

This part of the function has two output status signals:

- DIS21_PSDDet_GrI_ to detect power swings. For instance, the user has the possibility to block one or more distance protection zones during power swings using the DIS21_Zn_Blk_GrO_ output status of the graphic equation editor.
- DIS21_PSDslow_GrI_ to detect slow power swings. This status has signaling purposes only.

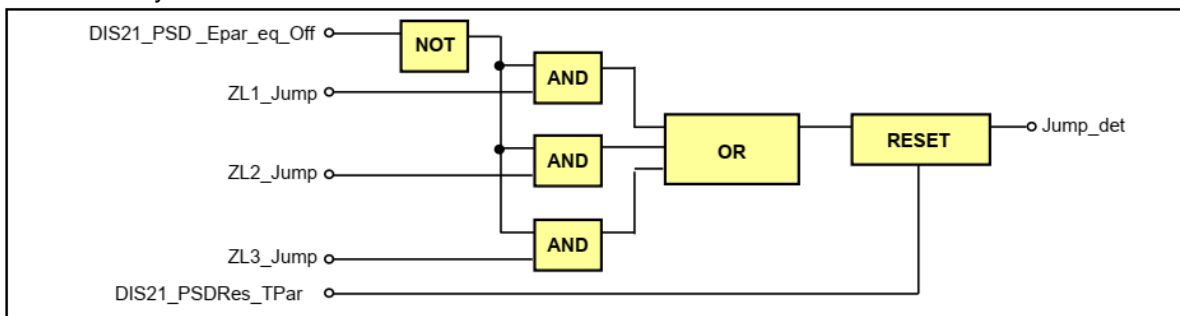

Figure 1-20 Impedance jump detection

Figure 1-20 shows that if impedance jump is detected (i.e., the change of the reactance and resistance values between two consecutive samples is greater than $\frac{1}{4}$ of the PSD margin setting) in any of the phases, then the “Jump_det” condition is true for the “reset” time.

The impedance jump is an internal signal. If during power swings the impedance “jumps”, this means a fault during the swings and the power swing state must be terminated. (see Figure 1-19)

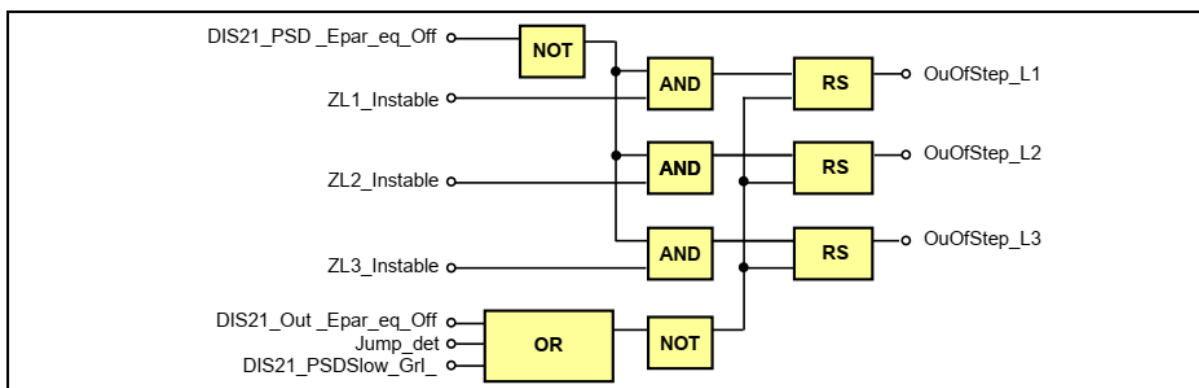

Figure 1-21 Out-of-step condition detection in the individual phases

If the swings are instable, the sign of the resistive component of the impedance at entrance is opposite to the sign of the resistance calculated at leaving the characteristics. Figure 1-21 shows that “Out-of-step condition” is detected in the individual phases if instable state is measured (i.e., the sign of the resistive component is opposite if the impedance enters and if it exits the PSD characteristics). The function can be disabled using the enumerated parameter **Operation PSD** if it is set to “Off”. This function also resets if the out-of-step function is disabled by the parameter **Oper OutOfStep** by setting it to “Off”, or an impedance jump is detected (“Jump_det”) according to Figure 1-20 or a slow swing is detected (see “DIS21_PSDslow_GrI_” on Figure 1-19 above).

In this case, the algorithm can generate the out-of-step tripping condition DIS21_OutTr_GrI_. The duration of this impulse is determined by the parameter **OutOfStep Pulse**.

The “very slow swing” condition DIS21_PSDslow_Grl_ is generated if the duration of measuring the impedance within the rectangle is longer than the parameter setting **Very Slow Swing**.

All these binary output signals can serve as binary inputs for the graphic equations, to be programmed by the user.

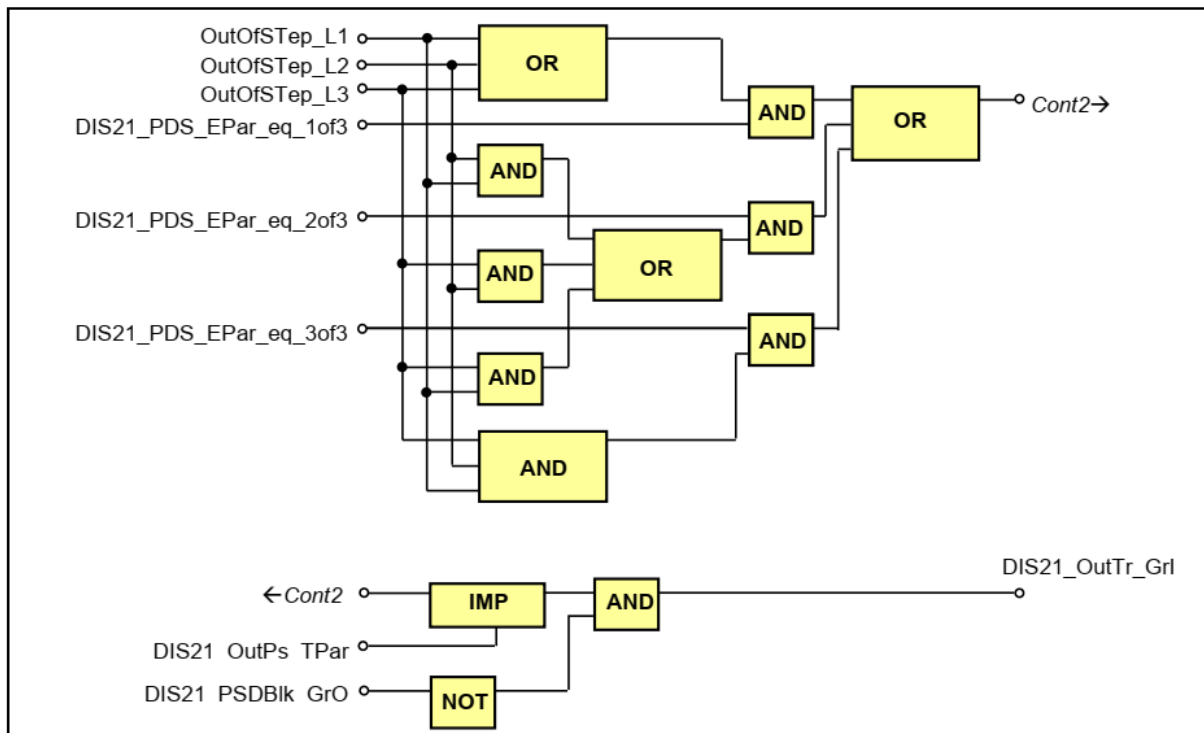

Figure 1-22 Out-of-step trip command generation

According to Figure 1-22, the out-of-step conditions in the individual phases can result in an out-of-step trip command impulse only if the combination of the phases corresponds to the parameter setting **Operation PSD** (which can be 1 out of 3, 2 out of 3, 3 out of 3).

The duration of the trip command can be set using the parameter **OutOfStep Pulse**.

4.1.1.1.7. The distance-to-fault calculation (FAULT LOCATOR)

The distance protection function selects the faulty loop impedance (its positive sequence component) and calculates the distance to fault based on the measured positive sequence reactance and the total reactance of the line. This reference value is given as a parameter setting **Line Reactance**. The calculated percentage value facilitates displaying the distance in kilometers if the total length of the line is correctly set by the parameter **Line Length**.



The fault locator works only for the faults detected in Zone1 or Zone2 only.

Table 1-36 The floating point parameters

PARAMETER NAME	TITLE	DIM.	MIN	MAX	STEP	DEFAULT
DIS21_Lgth_FPar_	Line Length	km	0.1	1000	0.01	100
DIS21_LReact_FPar_	Line Reactance	ohm	0.1	200	0.01	10

4.1.1.1.8. The high-speed overcurrent protection function with switch-onto-fault logic (HSOC SOTF)

The switch-onto-fault protection function can generate an immediate trip command if the function is enabled and switch-onto-fault condition is detected. The condition of the operation can be the non-directional starting signal of any distance protection zone as it is selected by a dedicated parameter, or it can be the operation of the high-speed overcurrent protection function.

The high-speed overcurrent protection function operates if a sampled value of the phase current is above the setting value.

Table 1-37 The binary output status signals of the SOTF function

BINARY OUTPUT SIGNALS	SIGNAL TITLE	EXPLANATION
SOTF function		
DIS21_SOTFTr_GrI_	SOTF Trip	The distance protection function generated a trip command caused by switching onto fault

The **binary input** is a signal influencing the operation of the distance protection function. This signal is the result of logic equations graphically edited by the user.

Table 1-38 The binary input signals of the SOTF function

BINARY INPUT SIGNALS	SIGNAL TITLE	EXPLANATION
DIS21_SOTFCond_GrO_	SOTF COND.	Status signal indicating switching-onto-fault-condition

The parameters of the SOTF function are explained in the following tables.

Table 1-39 The enumerated parameters of the SOTF logic

PARAMETER NAME	TITLE	SELECTION RANGE	DEFAULT
Parameter for selecting one of the zones or “high speed overcurrent protection” for the “switch-onto-fault” function:			
DIS21_SOTFMd_EPar _	SOTF Zone	Off, Zone1, Zone2, Zone3, Zone4, Zone5, HSOC	Zone1

Parameters for the individual zones to be blocked by the power swing detection (PSD) function:

Table 1-40 The integer parameters of the SOTF logic

PARAMETER NAME	TITLE	UNIT	MIN	MAX	STEP	DEFAULT
Definition of the overcurrent setting for the switch-onto-fault function, for the case where the DIS21_SOTFMd_EPar_ (SOTF Zone) parameter is set to “HSOC”:						
DIS21_SOTFOC_IPar_	SOTF Current	%	10	1000	1	200

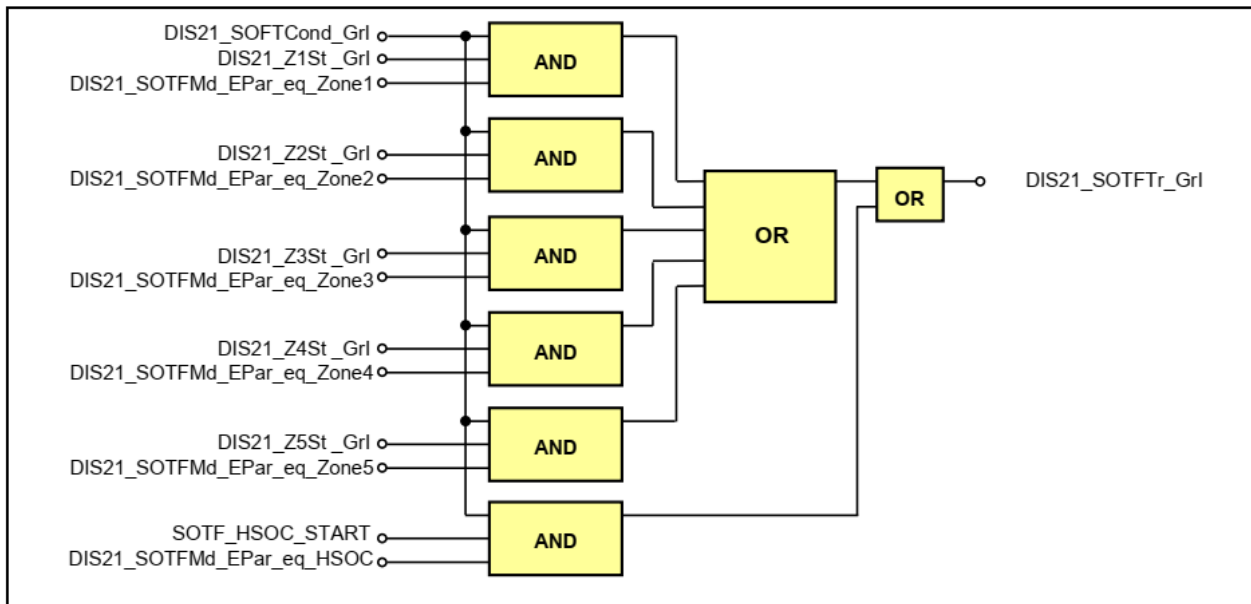

Figure 1-23 The internal logic of the SOTF function

In this diagram, the additional binary input signals:

Table 1-41 The binary input signals of the SOTF logic

BINARY INPUT SIGNALS	SIGNAL TITLE	EXPLANATION
DIS21_Z1St_Grl	Z1 Start	Started state of the distance protection Zone1 (non-directional)
DIS21_Z2St_Grl	Z2 Start	Started state of the distance protection Zone2 (non-directional)
DIS21_Z3St_Grl	Z3 Start	Started state of the distance protection Zone3 (non-directional)
DIS21_Z4St_Grl	Z4 Start	Started state of the distance protection Zone4 (non-directional)
DIS21_Z5St_Grl	Z5 Start	Started state of the distance protection Zone5 (non-directional)
SOTF_HSOC_START		Started state of the HSOC function

4.1.1.1.9. The on-line measured values of the distance protection function

Table 1-42 The measured values of the distance protection function

NAME	TITLE	EXPLANATION
DIS21_HTXkm_OLM_	Fault location	Measured distance to fault in kilometers
DIS21_HTXohm_OLM_	Fault react.	Measured reactance to fault
DIS21_L1N_R_OLM_	L1N loop R	Measured positive sequence resistance in L1N loop
DIS21_L1N_X_OLM_	L1N loop X	Measured positive sequence reactance in L1N loop
DIS21_L2N_R_OLM_	L2N loop R	Measured positive sequence resistance in L2N loop
DIS21_L2N_X_OLM_	L2N loop X	Measured positive sequence reactance in L2N loop
DIS21_L3N_R_OLM_	L3N loop R	Measured positive sequence resistance in L3N loop
DIS21_L3N_X_OLM_	L3N loop X	Measured positive sequence reactance in L3N loop
DIS21_L12_R_OLM_	L12 loop R	Measured positive sequence resistance in L12 loop
DIS21_L12_X_OLM_	L12 loop X	Measured positive sequence reactance in L12 loop
DIS21_L23_R_OLM_	L23 loop R	Measured positive sequence resistance in L23 loop
DIS21_L23_X_OLM_	L23 loop X	Measured positive sequence reactance in L23 loop
DIS21_L31_R_OLM_	L31 loop R	Measured positive sequence resistance in L31 loop
DIS21_L31_X_OLM_	L31 loop X	Measured positive sequence reactance in L31 loop

4.1.1.2. Overview

The graphic appearance of the function block of the 5 zone HV distance protection function is shown on [Figure 2-1](#).

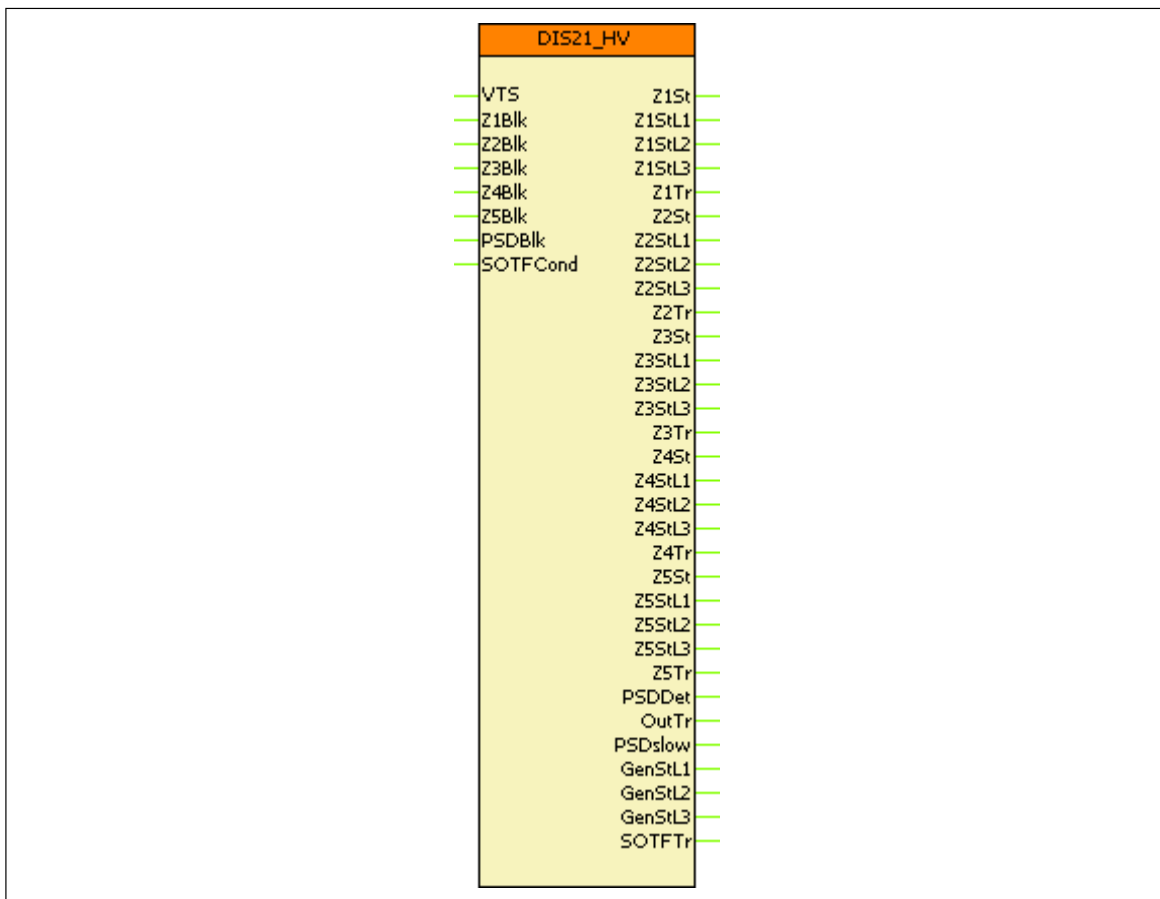
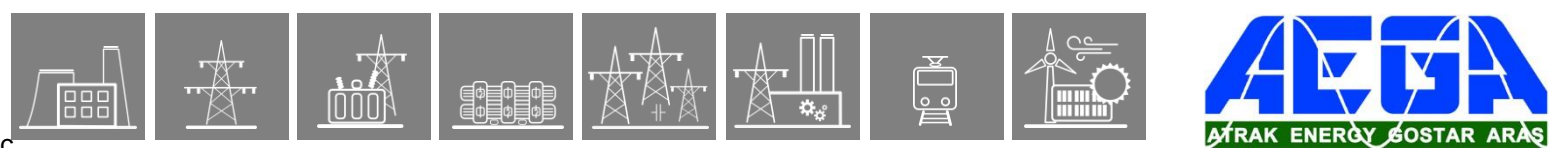

Figure 2-1 Graphic appearance of the function block of the distance protection function



4.1.1.2.1. Settings

4.1.1.2.1.1. Parameters

The parameters are listed as they are seen on the local or remote HMI.

Table 2-1 Parameters of the distance function

TITLE	DIM	RANGE	STEP	DEFAULT	EXPLANATION
<i>General parameters</i>					
I _{Ph} Base Sens	%	10 – 30	1	20	Definition of the minimal current enabling the impedance calculation
I _{Res} Base Sens	%	10 – 50	1	10	1 st part of the of the zero sequence current characteristic enabling impedance calculation in phase-to-earth loops
I _{Res} Bias	%	5 – 30	1	10	Slope of the zero sequence current characteristic enabling impedance calculation in phase-to-earth loops
Angle 2nd Quad	deg	0 – 30	1	15	Definition of the polygon characteristic angle in the 2 nd quadrant of the impedance plane
Angle 4th Quad	deg	0 – 30	1	15	Definition of the polygon characteristic angle in the 4 th quadrant of the impedance plane
Line Angle	deg	45 – 90	1	75	Definition of the line angle
Par. Line X _{om} /3X ₁	-	0.00 – 5.00	0.01	0.00	β_L parallel line coupling factor where X _{om} is the imaginary part of the mutual impedance between the protected and the parallel line
Par. Line R _{om} /3R ₁	-	0.00 – 5.00	0.01	0.00	β_R parallel line coupling factor where R _{om} is the real part of the mutual impedance between the protected and the parallel line
<i>Data for the Fault Locator</i>					
Line Length	km	0.1 – 1000.0	0.1	100.0	
Line Reactance	Ohm		0.01	10.00	Reactance (X) of the line. The fault locator is using the reactance of the fault and the line to calculate the distance.
<i>Load encroachment</i>					
Load Angle	deg		1	30	Definition of the load angle of the polygon characteristic
R Load	ohm		0.01	10.00	Load encroachment setting
<i>Specific parameters of each zone</i>					
Operation Zone1	-	Off, Forward, Backward	-	Off	Selection of directionality for Zone1
Zone1 Start Only	-	FALSE, TRUE	-	FALSE	FALSE for Zone1 to generate trip command
PSD Block Z1	-	FALSE, TRUE	-	FALSE	TRUE for Zone1 to be blocked by PSD
Zone Reduct Angle	ohm	0 – 40	1	40	Definition of the polygon characteristic's zone reduction angle on the impedance plane
Zone1 R	ohm	0.01 – 200.00	0.01	10.00	R setting for Zone1 in secondary value. The characteristic crosses the R axis at this point)

Zone1 X	ohm	0.01 – 200.00	0.01	10.00	X setting for Zone1 in secondary value
Zone1 (Xo-X1)/3X1	-	0.00 – 5.00	0.01	1.00	α_L zero sequence current compensation factor for Zone1
Zone1 (Ro-R1)/3R1	-	0.00 – 5.00	0.01	1.00	α_R zero sequence current compensation factor for Zone1
Zone1 Time Delay	msec	0 – 60000	1	0	Delay of Zone1: the time between the rising edges of the Start and Trip signals of Zone1
Operation Zone2	-	Off, Forward, Backward, NonDirectional	-	Off	Selection of directionality for Zone2
Zone2 Start Only	-	FALSE, TRUE	-	FALSE	FALSE for Zone2 to generate trip command
PSD Block Z2	-	FALSE, TRUE	-	FALSE	TRUE for Zone2 to be blocked by PSD
Zone2 R	ohm	0.01 – 200.00	0.01	10.00	R setting for Zone2 in secondary value. The characteristic crosses the R axis at this point)
Zone2 X	ohm	0.01 – 200.00	0.01	10.00	X setting for Zone2 in secondary value
Zone2 (Xo-X1)/3X1	-	0.00 – 5.00	0.01	1.00	α_L zero sequence current compensation factor for Zone2
Zone2 (Ro-R1)/3R1	-	0.00 – 5.00	0.01	1.00	α_R zero sequence current compensation factor for Zone2
Zone2 Time Delay	msec	40 – 60000	1	400	Delay of Zone2: the timer runs from the emergence of the fault to the Trip signal
Operation Zone3	-	Off, Forward, Backward, NonDirectional	-	Off	Selection of directionality for Zone3
Zone3 Start Only	-	FALSE, TRUE	-	FALSE	FALSE for Zone3 to generate trip command
PSD Block Z3	-	FALSE, TRUE	-	FALSE	TRUE for Zone3 to be blocked by PSD
Zone3 R	ohm	0.01 – 200.00	0.01	10.00	R setting for Zone3 in secondary value. The characteristic crosses the R axis at this point)
Zone3 X	ohm	0.01 – 200.00	0.01	10.00	X setting for Zone3 in secondary value
Zone3 (Xo-X1)/3X1	-	0.00 – 5.00	0.01	1.00	α_L zero sequence current compensation factor for Zone3
Zone3 (Ro-R1)/3R1	-	0.00 – 5.00	0.01	1.00	α_R zero sequence current compensation factor for Zone3
Zone3 Time Delay	msec	40 – 60000	1	800	Delay of Zone3: the timer runs from the emergence of the fault to the Trip signal
Operation Zone4	-	Off, Forward, Backward, NonDirectional	-	Off	Selection of directionality for Zone4
Zone4 Start Only	-	FALSE, TRUE	-	FALSE	FALSE for Zone4 to generate trip command
PSD Block Z4	-	FALSE, TRUE	-	FALSE	TRUE for Zone4 to be blocked by PSD
Zone4 R	ohm	0.01 – 200.00	0.01	10.00	R setting for Zone4 in secondary value. The characteristic crosses the R axis at this point)
Zone4 X	ohm	0.01 – 200.00	0.01	10.00	X setting for Zone4 in secondary value

Very Slow Swing	msec	100 – 10000	1	500	The “very slow swing” condition is generated if the duration of measuring the impedance within the rectangle is longer than the setting
PSD Reset	msec	100 – 10000	1	500	Setting for delaying the drop-off of the PSD detection, very slow swing detection and jump detection signals
OutOfStep Pulse	msec	50 – 10000	1	150	Length of the pulse generated by the out-of-step function

4.1.1.2.1.2. Characteristics

The function uses a 5-zone quadrilateral characteristic with load encroachment (see [Figure 2-2](#)).

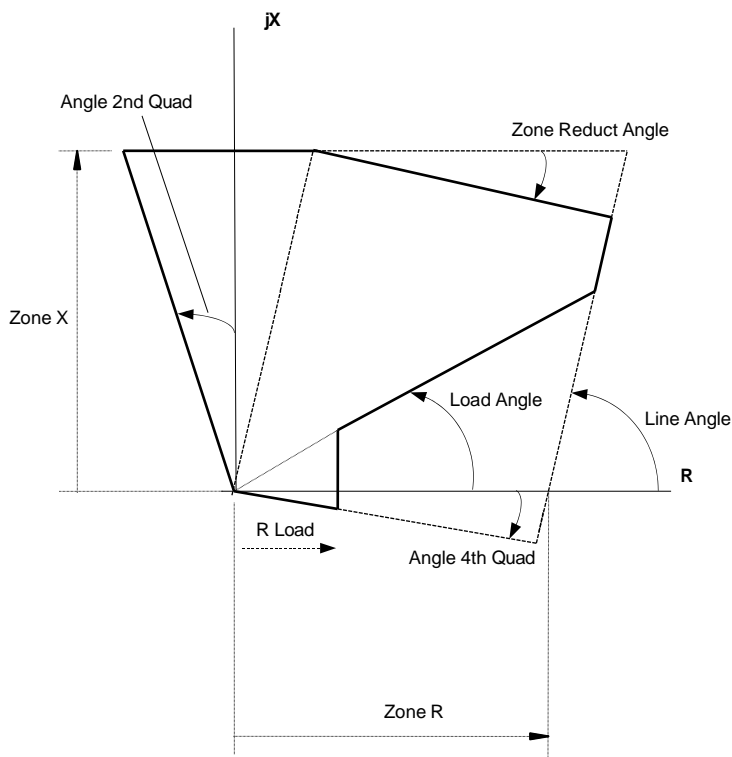

Figure 2-2 The polygon characteristics of the distance protection function on the complex plane

Earth-fault detection is based on a 1-slope biased characteristic, see [Figure 2-3](#).

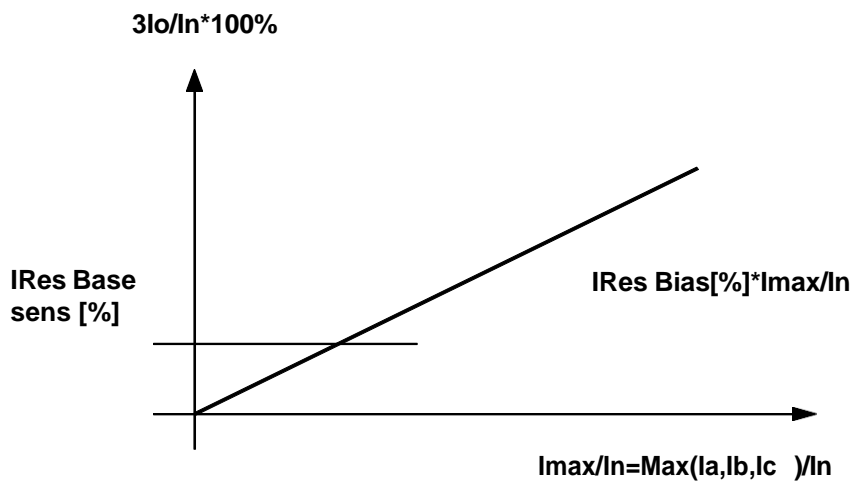
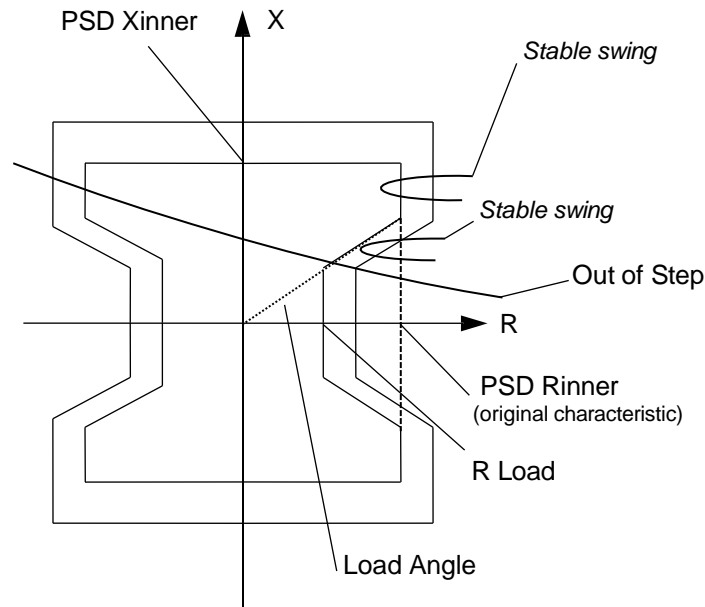

Figure 2-3 Percentage characteristic for earth-fault detection

Power swing and out-of-step detection is based on the characteristic shown in [Figure 2-4](#).



Ratio of the outer characteristics related to the inner one is set by:

- $PSD R_{out}/R_{in}$
- $PSD X_{out}/X_{in}$

The load encroachment setting for the polygon inside is the same as for the distance characteristic:

- R Load
- Load Angle

The polygon outside can be calculated by shifting the load encroachment points parallel to the „R” axis, by the ratio

- $PSD R_{out}/R_{in}$

Figure 2-4 Characteristics of the power swing detection function

4.1.1.2.2. Function I/O

This section describes briefly the analogue and digital inputs and outputs of the function block.

4.1.1.2.2.1. Analogue inputs

The function uses the following analogue signals as inputs:

- Sampled values of the three phase voltages
- Sampled values of the three phase currents
- Sampled values of the zero sequence current of the parallel line
- Basic Fourier components of the three phase voltages
- Basic Fourier components of the three phase currents
- Basic Fourier component of the zero sequence current of the parallel line
- Calculated line-to-line values the three phase voltages
- Calculated positive, negative and zero sequence values the three phase voltages
- Calculated line-to-line values the three phase currents
- Calculated positive, negative and zero sequence values the three phase currents

4.1.1.2.2.2. Analogue outputs (measurements)

The measured values of the differential protection function are listed in the table below.

Table 2-2 The measured analogue values of the 5-zone HV distance protection function

MEASURED VALUE	DIMENSION	EXPLANATION
Fault location	km	Calculated distance of the last fault cleared in Zone1 or Zone2
Fault react.	ohm	Measured reactance of the last fault cleared in Zone1 or Zone2
L1N loop R	ohm	Currently measured resistance in the L1N loop
L1N loop X	ohm	Currently measured reactance in the L1N loop
L2N loop R	ohm	Currently measured resistance in the L2N loop
L2N loop X	ohm	Currently measured reactance in the L2N loop
L3N loop R	ohm	Currently measured resistance in the L3N loop
L3N loop X	ohm	Currently measured reactance in the L3N loop
L12 loop R	ohm	Currently measured resistance in the L12 loop
L12 loop X	ohm	Currently measured reactance in the L12 loop
L23 loop R	ohm	Currently measured resistance in the L23 loop
L23 loop X	ohm	Currently measured reactance in the L23 loop
L31 loop R	ohm	Currently measured resistance in the L31 loop
L31 loop X	ohm	Currently measured reactance in the L31 loop

4.1.1.2.2.3. Binary input signals (graphed output statuses)

The conditions of the inputs are defined by the user, applying the graphic equation editor (logic editor). The part written in **bold** is seen on the function block in the logic editor.

Table 2-3 The binary input signals of the 5-zone HV distance protection function

BINARY INPUT SIGNAL	EXPLANATION
DIS21_VTS_GrO_	Output status of a graphic equation defined by the user to disable the function. Only the measurements work and are displayed.
DIS21_Z1BIk_GrO_	Block Zone1
DIS21_Z2BIk_GrO_	Block Zone2
DIS21_Z3BIk_GrO_	Block Zone3
DIS21_Z4BIk_GrO_	Block Zone4
DIS21_Z5BIk_GrO_	Block Zone5
DIS21_PSDBIk_GrO_	Block the Power Swing Detection function
DIS21_SOTFCond_GrO_	The SOTF logic is active while this input is active (see Chapter 1.8).

Z5 Start L1	-	Start in phase L1 of Zone5
Z5 Start L2	-	Start in phase L2 of Zone5
Z5 Start L3	-	Start in phase L3 of Zone5
Z5 Trip	-	Trip signal generated in Zone5
PSD Detect	-	Signal of detected power swing
OutOfStep Trip	-	Signal of out-of-step tripping condition
VerySlow Swing	-	Signal of detected very slow power swing

4.1.1.2.2.6. Events

The following events are generated in the event list, as well as sent to SCADA according to the configuration.

Table 2-6 Events of the 5-zone HV distance protection function

EVENT	VALUE	EXPLANATION
Z1 Start	off, on	General start of Zone1
Z1 Trip	off, on	Trip signal generated in Zone1
Z1 FaultLoop	N/A, L1-N, L2-N, L3-N, L1-L2, L2-L3, L3-L1, L1-L2-L3	Impedance loop of the fault was detected in in Zone1
Z2 Start	off, on	General start of Zone2
Z2 Trip	off, on	Trip signal generated in Zone2
Z2 FaultLoop	N/A, L1-N, L2-N, L3-N, L1-L2, L2-L3, L3-L1, L1-L2-L3	Impedance loop of the fault was detected in in Zone2
Z3 Start	off, on	General start of Zone3
Z3 Trip	off, on	Trip signal generated in Zone3
Z3 FaultLoop	N/A, L1-N, L2-N, L3-N, L1-L2, L2-L3, L3-L1, L1-L2-L3	Impedance loop of the fault was detected in in Zone3
Z4 Start	off, on	General start of Zone4
Z4 Trip	off, on	Trip signal generated in Zone4
Z4 FaultLoop	N/A, L1-N, L2-N, L3-N, L1-L2, L2-L3, L3-L1, L1-L2-L3	Impedance loop of the fault was detected in in Zone4
Z5 Start	off, on	General start of Zone5
Z5 Trip	off, on	Trip signal generated in Zone5
Z5 FaultLoop	N/A, L1-N, L2-N, L3-N, L1-L2, L2-L3, L3-L1, L1-L2-L3	Impedance loop of the fault was detected in in Zone5
SOTF condition	off, on	The SOTFCond input of the function block is active.
SOTF Trip	off, on	The distance protection function generated a trip command caused by switching onto fault
Start L1	off, on	General start in phase L1
Start L2	off, on	General start in phase L2
Start L3	off, on	General start in phase L3
Start Neut	off, on	The zero sequent current component is sufficient for earth fault calculation
PSD Detect	off, on	Power swing is detected
OutOfStep Trip	off, on	Out-of-step tripping condition is active
Fault Loc. km	[measured distance]	Calculated distance of the last fault cleared in Zone1 or Zone2

4.1.1.2.2.7. Indication of the fault direction and loop in each Zone

There are internal status variables created to indicate the direction and the fault loop in the zones. These variables are defined as integer statuses, which can be browsed in the EuroCAP program to have them displayed.

Table 2-7 The displayed on-line data of the 5-zone HV distance protection function

INTEGER STATUS	TITLE	VALUE	EXPLANATION
DIS21_Z1Dir_ISt_	Z1 Direction	0: unknown 1: forward 2: backward	Integer status signal indicating the direction of the measured impedance in Zone1
DIS21_Z1Loop_ISt_	Z1 FaultLoop	0: N/A 1: L1-N 2: L2-N 3: L3-N 4: L1-L2 5: L2-L3 6: L3-L1 7: L1-L2-L3	Indication of the impedance loop of the fault detected in Zone1.
DIS21_Z2Dir_ISt_	Z2 Direction	0: unknown 1: forward 2: backward	Integer status signal indicating the direction of the measured impedance in Zone2
DIS21_Z2Loop_ISt_	Z2 FaultLoop	0: N/A 1: L1-N 2: L2-N 3: L3-N 4: L1-L2 5: L2-L3 6: L3-L1 7: L1-L2-L3	Indication of the impedance loop of the fault detected in Zone2.
DIS21_Z3Dir_ISt_	Z3 Direction	0: unknown 1: forward 2: backward	Integer status signal indicating the direction of the measured impedance in Zone3
DIS21_Z3Loop_ISt_	Z3 FaultLoop	0: N/A 1: L1-N 2: L2-N 3: L3-N 4: L1-L2 5: L2-L3 6: L3-L1 7: L1-L2-L3	Indication of the impedance loop of the fault detected in Zone3.
DIS21_Z4Dir_ISt_	Z4 Direction	0: unknown 1: forward 2: backward	Integer status signal indicating the direction of the measured impedance in Zone4
DIS21_Z4Loop_ISt_	Z4 FaultLoop	0: N/A 1: L1-N 2: L2-N 3: L3-N 4: L1-L2 5: L2-L3 6: L3-L1 7: L1-L2-L3	Indication of the impedance loop of the fault detected in Zone4.

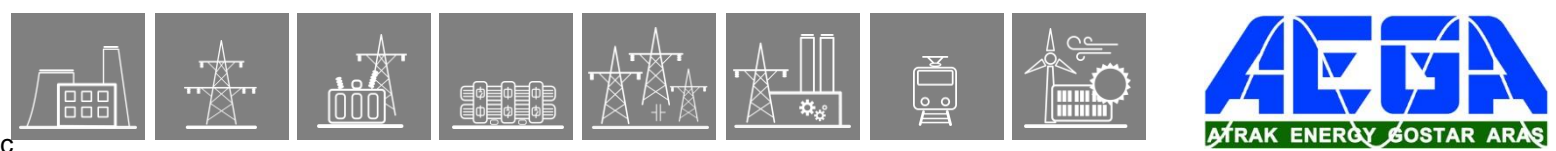

DIS21_Z5Dir_ISt_	Z5 Direction	0: unknown 1: forward 2: backward	Integer status signal indicating the direction of the measured impedance in Zone5
DIS21_Z5Loop_ISt_	Z5 FaultLoop	0: N/A 1: L1-N 2: L2-N 3: L3-N 4: L1-L2 5: L2-L3 6: L3-L1 7: L1-L2-L3	Indication of the impedance loop of the fault detected in Zone5.

4.1.1.2.3. Technical data

The technical data are based on the function block testing according to the directives of the IEC 60255-121:2014 standard.

Table 2-8 Technical data of the 5-zone HV distance protection

FUNCTION	VALUE
Number of zones	5
Rated current (I_n)	1/5A, parameter setting
Rated voltage (U_n)	100/200V phase to phase, parameter setting
Effective range – current	50% – 2000% I_n
Operating range – current	10% – 5000% I_n
Effective range – voltage	10% – 130% U_n
Operating range – voltage	0% – 130% U_n
Effective and operating range – frequency $f_n = 50$ Hz $f_n = 60$ Hz	49Hz – 51Hz 58.8Hz – 61.2Hz
Impedance effective setting range (may differ from the technical setting range of the parameters) $U_n = 57,74V; I_n = 1A$ $U_n = 57,74V; I_n = 5A$	0.1 – 200 Ω 0.1 – 40 Ω
Characteristic accuracy ϵ_x $U_n = 57,74V I_n = 1A; f_n = 50$ Hz $U_n = 57,74V I_n = 1A; f_n = 60$ Hz	$\pm 1,6$ % $\pm 1,8$ %
Characteristic accuracy ϵ_R $U_n = 57,74V I_n = 1A; f_n = 50$ Hz $U_n = 57,74V I_n = 1A; f_n = 60$ Hz	$\pm 3,6$ % $\pm 2,8$ %
Basic directional accuracy	$\pm 0,9^\circ$
Operate time (Zone 1)	27ms \pm 8ms
Min. operate time	19 ms
Time delay accuracy ($t = 30$ sec)	$\pm 2,7$ ms
Reset time	68 ms
Reset ratio	1.1

4.1.1.2.3.1. Notes for testing

XRIO file is available for the function for setting up the tests easily and correctly.

Normally in the EuroProt+ devices the trip contacts are assigned to the Trip Logic function block, and not to the protection function blocks. Because of this the testing personnel must make sure that the Trip Logic is switched on ('Operation' parameter is set to other than 'Off') before starting the testing, otherwise there will be no physical trip on the relay.

The set delays are to be evaluated as follows:

- *Zone1*: the delay is between the rising edges of the Start and Trip signal
- *Zone2-5*: the delay is between the injection of the fault and the Trip signal, so the setting must be at least 35-40 ms (lower value will not result in lower operation times in these zones)



By default, either output (AutoSOTF or ManSOTF) of the external "SOTF Condition" function block is connected to the SOTFCond input of the Distance protection function block. See its description on the Protecta webpage for more information (Switch-onto-fault preparation function). Before testing, it is advised to check its logical connections to see what circumstances cause SOTF operation in the Distance protection function.

The fault locator works only for the faults detected in Zone1 or Zone2 only.

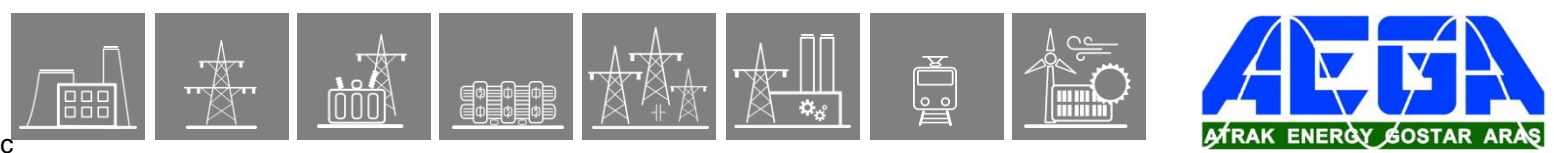

Earth fault compensation factors (when xrio file is not used):

The formula of the earth fault compensation factors is as follows

- $\alpha_R = (R_0 - R_1) / 3R_1$ for the resistance and
- $\alpha_L = (X_0 - X_1) / 3X_1$ for the reactance

Performing secondary injection to test the distance protection requires proper settings in the test equipment as well. When using Omicron or ISA relay testers, please use the RE/RL and XE/XL mode for earth fault compensation factor definition. These will correspond to the above formulas:

$$RE/RL = (R_0 - R_1) / 3R_1 = \alpha_R$$

$$XE/XL = (X_0 - X_1) / 3X_1 = \alpha_L$$

These data are needed to calculate the necessary factors. It is not possible to calculate the factors using only the complex earth fault compensation factor.

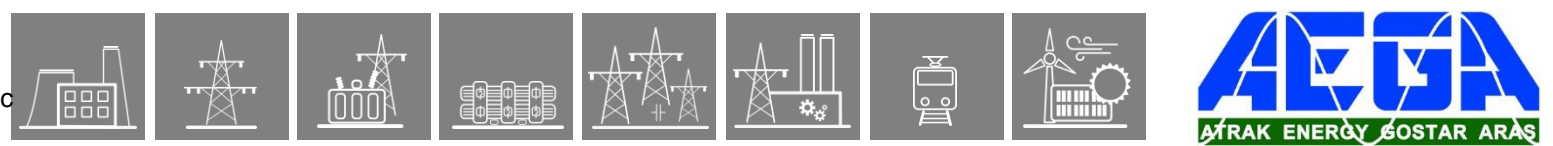

4.1.2. Distance protection function with MHO characteristics

The distance protection function provides main protection for overhead lines and cables of solidly grounded networks. Its main features are as follows:

- A full-scheme system provides continuous measurement of impedance separately in three independent phase-to-phase measuring loops as well as in three independent phase-to-earth measuring loops.
- The complex earth fault compensation factor is applied for correct impedance measuring on single-phase-to-earth fault.
- Analogue input processing is applied to the zero sequence current of the parallel line.
- Impedance calculation is conditional of the values of phase currents being sufficient. The current is considered to be sufficient for impedance calculation if it is above the level set by parameter(s).
- To decide the presence or absence of the zero sequence current, biased characteristics are applied.
- Full-scheme faulty phase identification by minimum impedance detection.
- Five independent distance protection zones are configured.
- The operating decision is based on MHO or on offset circle characteristics.
- Load encroachment characteristics can be selected,
- The directional decision is dynamically based on:
 - measured loop voltages if they are sufficient for decision,
 - healthy phase voltages if they are available for asymmetrical faults,
 - voltages stored in the memory if they are available,
- The operation of any zones is non-directional if it is optionally selected.
- The distance protection function can operate properly if CVT is applied as well.
- Non-directional impedance protection function or high speed OC protection function is applied in case of switch-onto-fault.
- Distance-to-fault evaluation is implemented (fault locator function).
- Binary input signals and conditions can influence the operation:
 - blocking/enabling
 - VT failure signal
- Integrated high-speed overcurrent back-up function is also implemented.
- The power swing detection function can block the distance protection function in case of stable swings, or it can generate a trip command if the system operates out of step.

4.1.2.1. Structure of the distance protection algorithm

Fig.1-1 shows the structure of the 5-zone HV Distance protection (DIS21_HV) algorithm.

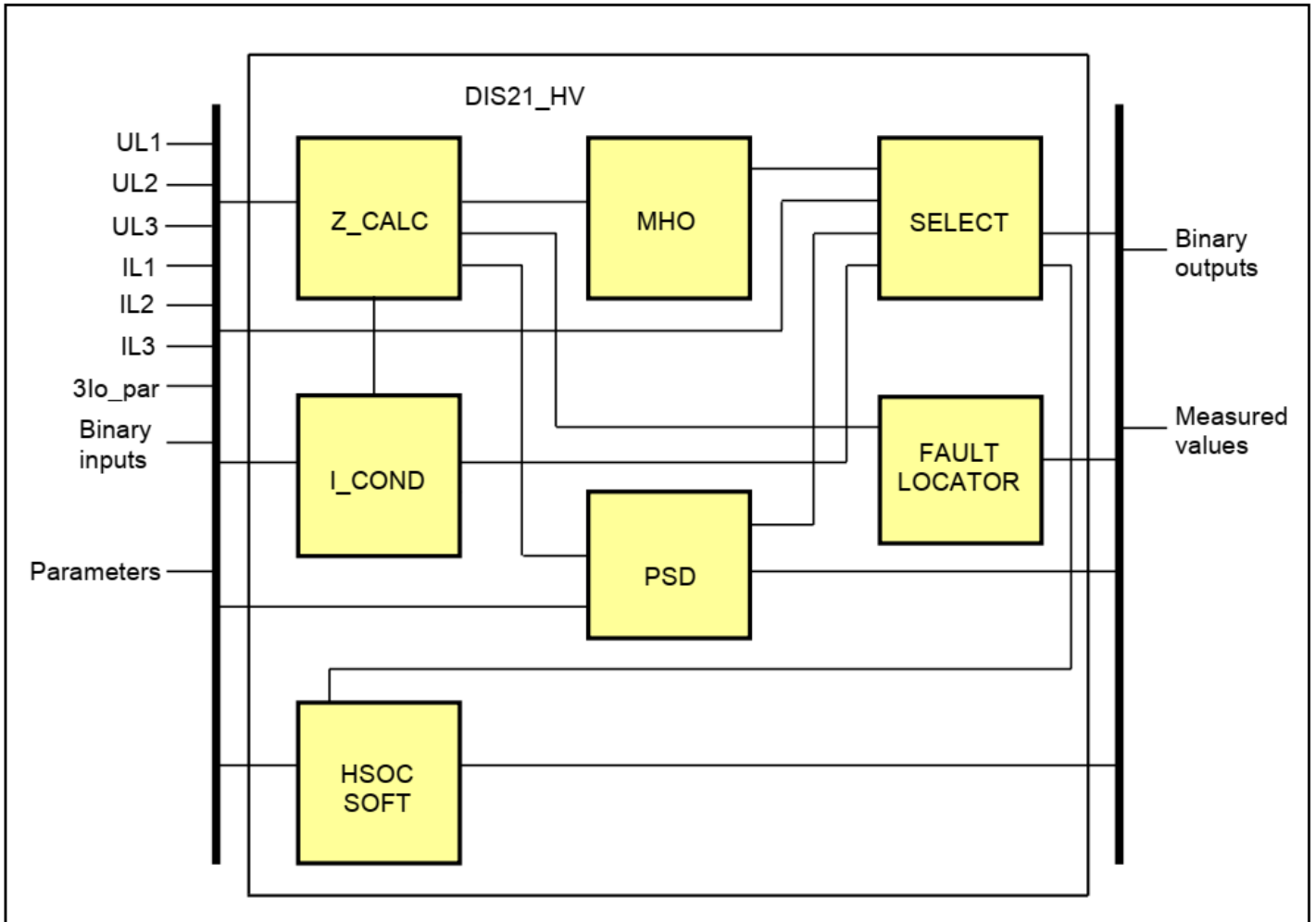
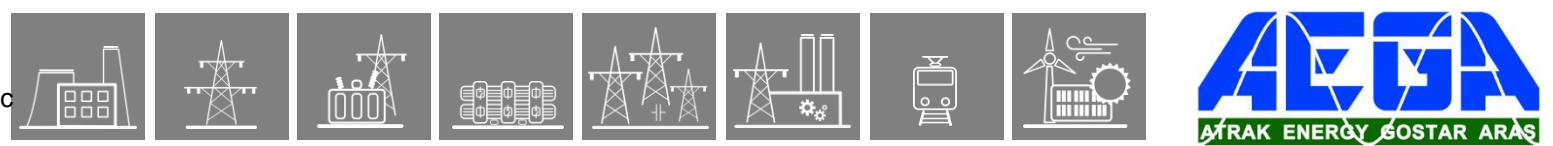

Figure 1-1 Structure of the distance protection algorithm



The **inputs** are

- the sampled values and Fourier components of three phase voltages,
- the sampled values and Fourier components of three phase currents,
- the sampled values and Fourier components of (3I_{0p}) the zero sequence current of the parallel line,
- binary inputs,
- parameters.

The **outputs** are

- the binary output status signals,
- the measured values for displaying.

The **software modules** of the distance protection function are as follows:

Z_CALC calculates the impedances ($R+jX$) of the six measuring current loops:

- three phase-phase loops,
- three phase-ground loops.

MHO compares the calculated impedances with the setting values of the five MHO characteristics. The result is the decision for all six measuring loops and for all five circles if the impedance is within the MHO circle.

SELECT is the phase selection algorithm for all five zones to decide which decision is caused by a faulty loop and to exclude the false decisions in healthy loops.

I_COND calculates the current conditions necessary for the impedance calculation and for the phase selection logic.

PSD is the module that detects power swings and generates out-of-step trip command, influencing the distance protection function.

FAULT LOCATOR calculates the distance to fault after the trip command.

HSOC SOTF is a high-speed overcurrent protection function for the switch-onto-fault logic.

The following description explains the details of the individual components.

4.1.2.2. The impedance calculation (Z_CALC)

4.1.2.2.1. Principle of operation

The distance protection supplied by PROTECTA Ltd. continuously measures the impedances in the six possible fault loops. The calculation is performed in the phase-to-phase loops based on the line-to-line voltages and the difference of the affected phase currents, while in the phase-to-earth loops the phase voltage is divided by the phase current compounded with the zero sequence current. These equations are summarized in Table 1 for different types of faults. The result of this calculation is the positive sequence impedance of the fault loop, including the positive sequence fault resistance at the fault location.

For simplicity, the influence of the zero sequence current of the parallel line is not considered in these equations.

Fault	Calculation of Z	Other possible calculation
L1L2L3(N)	$Z_{L2L3} = \frac{U_{L2} - U_{L3}}{I_{L2} - I_{L3}}$	$Z_{L1L2}, Z_{L2L3}, Z_{L3L1}$ $Z_{L1N}, Z_{L2N}, Z_{L3N}$
L1L2	$Z_{L1L2} = \frac{U_{L1} - U_{L2}}{I_{L1} - I_{L2}}$	
L2L3	$Z_{L2L3} = \frac{U_{L2} - U_{L3}}{I_{L2} - I_{L3}}$	
L3L1	$Z_{L3L1} = \frac{U_{L3} - U_{L1}}{I_{L3} - I_{L1}}$	
L1L2N	$Z_{L1L2} = \frac{U_{L1} - U_{L2}}{I_{L1} - I_{L2}}$	Z_{L1N}, Z_{L2N}
L2L3N	$Z_{L2L3} = \frac{U_{L2} - U_{L3}}{I_{L2} - I_{L3}}$	Z_{L2N}, Z_{L3N}
L3L1N	$Z_{L3L1} = \frac{U_{L3} - U_{L1}}{I_{L3} - I_{L1}}$	Z_{L3N}, Z_{L1N}
L1N	$Z_{L1N} = \frac{U_{L1}}{I_{L1} + 3I_oK_N}$	
L2N	$Z_{L2N} = \frac{U_{L2}}{I_{L2} + 3I_oK_N}$	
L3N	$Z_{L3N} = \frac{U_{L3}}{I_{L3} + 3I_oK_N}$	

Table 1-1 Formulas for the calculation of the impedance to fault

The central column of Table 1-1 Formulas for the calculation of the impedance to fault contains the correct formula for calculation. The formulas referred to in the right-hand-side column yield the same correct impedance value.

In Table 1-1:

$$K_N = \frac{Z_o - Z_1}{3Z_1} = \frac{1}{3} \left(\frac{Z_o}{Z_1} - 1 \right)$$

is the *complex* earth fault compensation factor.

Table 1-1 shows that the formula containing the complex earth fault compensation factor yields the correct impedance value in case of phase-to-earth faults only; the other formula can be applied in case of phase-to-phase faults without ground. In case of other kinds of faults (three-phase (-to-earth), phase-to-phase-to-earth) both formulas give the correct impedance value if the appropriate voltages and currents are applied.

The separation of the two types of equations is based on the presence or absence of the earth (zero sequence) current. In case of a fault involving the earth (on a solidly grounded network), and if the earth current is over a certain level, the formula containing the *complex* earth fault compensation factor will be applied to calculate the correct impedance, which is proportional to the distance-to-fault.

It can be proven that if the setting value of the *complex* earth fault compensation factor is correct, the appropriate application of the formulas in Table 1-1 will always yield the positive sequence impedance between the fault location and the relay location.

4.1.2.2.2. General method of calculation of the impedances of the fault loops

If the sampled values are suitable for the calculation (after a zero crossing there are three sampled values above a defined limit $(-0.1I_n)$) then the numerical processes apply the following equations.

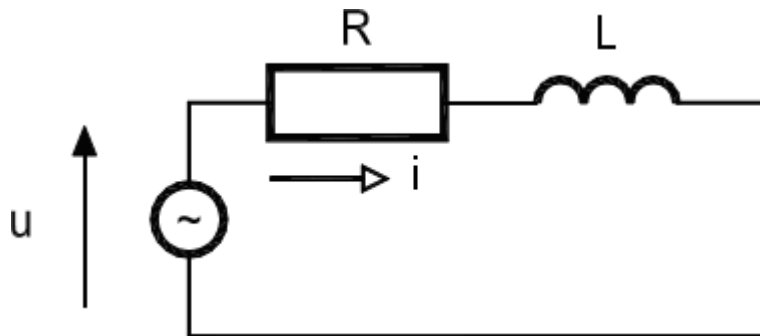

Equivalent circuit of the fault loop

For the equivalent impedance elements of the fault loop on the figure above, the following differential equation can be written:

$$u = Ri + L \frac{di}{dt}$$

If current and voltage values sampled at two separate sampling points in time are substituted in this equation, two equations are derived with the two unknown values R and L, so they can be calculated.

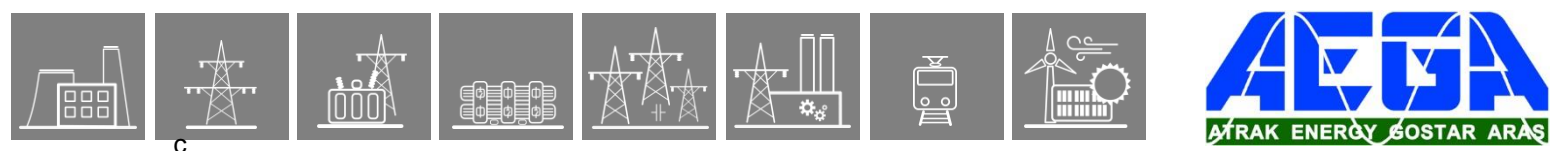

C

This basic principle is realized in the algorithm by substituting the sampled values of the line-to-line voltages for u and the difference of two phase currents in case of two- or three-phase faults without ground for i . For example, in case of an L2L3 fault:

$$u_{L2} - u_{L3} = R_1(i_{L2} - i_{L3}) + L_1 \frac{d(i_{L2} - i_{L3})}{dt}$$

In case of a phase-to-earth fault, the sampled phase voltage and the phase current modified by the zero sequence current have to be substituted:

$$u_{L1} = R_1(i_{L1} + \alpha_R 3i_o + \beta_R 3i_{op}) + L_1 \frac{d}{dt}(i_{L1} + \alpha_L 3i_o + \beta_L 3i_{op})$$

Where

- R_1 is the positive sequence resistance of the line or cable section between the fault location and the relay location,
- L_1 is the positive sequence inductance of the line or cable section between the fault location and the relay location,
- $L1$ is the faulty phase,
- $3i_o = iL1 + iL2 + iL3$ is the sampled value of the zero sequence current of the protected line,
- $3i_{op} = iL1_p + iL2_p + iL3_p$ is the sampled value of the zero sequence current in parallel line, and

$$\alpha_R = \frac{R_o - R_1}{3R_1}$$

$$\alpha_L = \frac{L_o - L_1}{3L_1} = \frac{X_o - X_1}{3X_1}$$

$$\beta_R = \frac{R_m}{3R_1}$$

$$\beta_L = \frac{L_m}{3L_1} = \frac{X_m}{3X_1}$$

- R_m is the real part of the mutual impedance between the protected and the parallel line,
- L_m is the mutual inductance between the protected and the parallel line.

The formula above shows that the factors for multiplying the R and L values contain different “ α ” and “ β ” factors but they are real (not complex) numbers.

The applied numerical method is solving the differential equation of the faulty loop, based on three consecutive samples.

To achieve a better filtering effect, Fourier basic harmonic components are substituted for the components of the differential equations.

4.1.2.2.3. The principal scheme of the impedance calculation

Fig.1-2 shows the principal scheme of the impedance calculation Z_CALC.

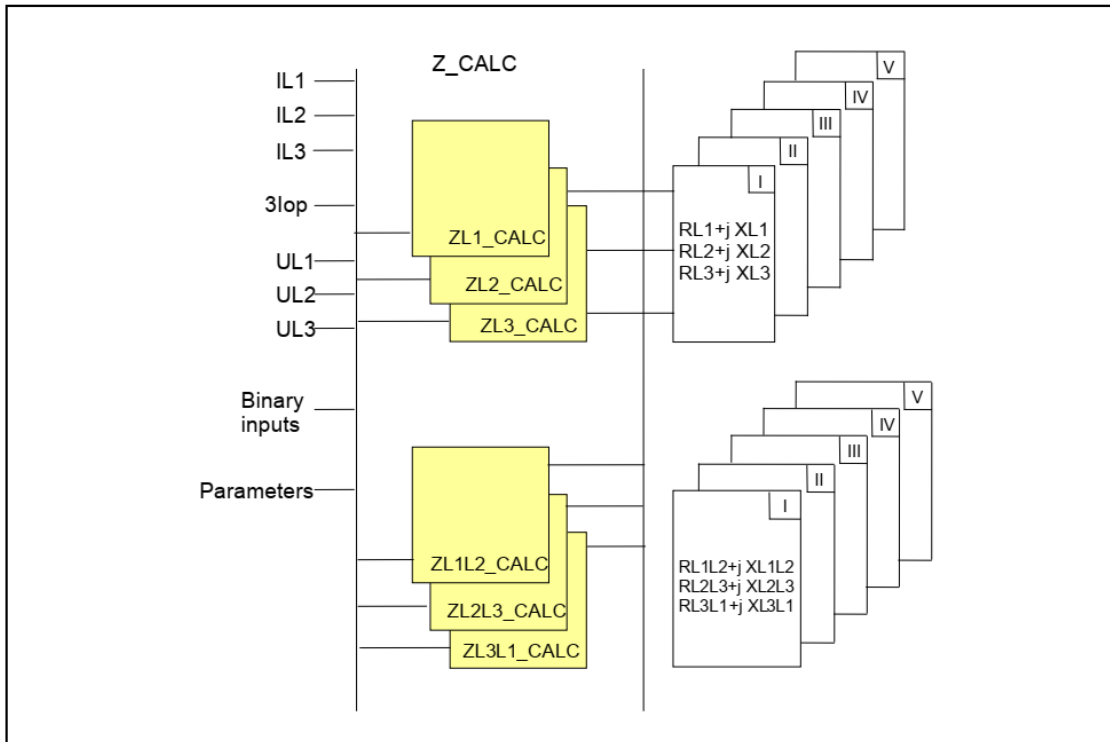

Fig. 1-2 Principal scheme of the impedance calculation Z_CALC.

The **inputs** are the sampled values and Fourier components of:

- the three phase voltages,
- the three phase currents,
- the (3Iop) zero sequence current of the parallel line,
- binary inputs,
- parameters.

The binary inputs are signals influencing the operation of the distance protection function. These signals are the results of logic equations graphically edited by the user.

Binary input signals

Binary input signal	Signal title	Explanation
DIS21_VTS_GrO_	Block from VTS	Blocking signal due to error in voltage measurement (Output of the user-defined graphic equation)
DIS21_SOTFCond_GrO_	SOTF COND.	Status signal indicating switching-onto-fault condition (Output of the user-defined graphic equation)

Table 1-2 Binary input signals for the impedance calculation

C

Enumerated parameters

Parameter name	Title	Selection range	Default
Parameters to select directionality of the individual zones:			
DIS21_Z1_EPar_	Operation Zone1	Off, Forward, Backward	Off
DIS21_Z2_EPar_	Operation Zone2	Off, Forward, Backward, Offset	Off
DIS21_Z3_EPar_	Operation Zone3	Off, Forward, Backward, Offset	Off
DIS21_Z4_EPar_	Operation Zone4	Off, Forward, Backward, Offset	Off
DIS21_Z5_EPar_	Operation Zone5	Off, Forward, Backward, Offset	Off
Parameter for selecting one of the zones or "high speed overcurrent protection" for the "switch-onto-fault" function:			
DIS21_SOTFMd_EPar_	SOTF Zone	Off,Zone1,Zone2,Zone3,Zone4,Zone5,H SOC	Zone1

Table 1-3 Enumerated parameters for the impedance calculation

Floating-point parameters

Parameter name	Title	Dim.	Min	Max	Default
DIS21_Z1aX_FPar_	Zone1 (Xo-X1)/3X1*		0	5.00	1
DIS21_Z1aR_FPar_	Zone1 (Ro-R1)/3R1*		0	5.00	1
DIS21_Z3aX_FPar_	Zone3 (Xo-X1)/3X1		0	5.00	1
DIS21_Z3aR_FPar_	Zone3 (Ro-R1)/3R1		0	5.00	1
DIS21_Z4aX_FPar_	Zone4 (Xo-X1)/3X1		0	5.00	1
DIS21_Z4aR_FPar_	Zone4 (Ro-R1)/3R1		0	5.00	1
DIS21_Z5aX_FPar_	Zone5 (Xo-X1)/3X1		0	5.00	1
DIS21_Z5aR_FPar_	Zone5 (Ro-R1)/3R1		0	5.00	1
DIS21_a2X_FPar_	Par.Line Xm/3X1		0	5.00	0
DIS21_a2R_FPar_	Par.Line Rm/3R1		0	5.00	0

* The values for Zone 2 are identical to those of Zone 1.

Table 1-4 Floating-point parameters for the impedance calculation

The **outputs** are the calculated positive-sequence impedances (R+jX) of the six measuring current loops and, as different zero sequence current compensation factors can be set for the individual zones, the impedances are calculated for each zone separately:

- Impedances of the three phase-phase loops,
- Impedances of the three phase-ground loops.

The **measured values** of the Z_CALC module

Measured value	Dim.	Explanation
RL1+j XL1	ohm	Measured positive sequence impedance in the L1N loop, using the zero sequence current compensation factor for zone 1
RL2+j XL2	ohm	Measured positive sequence impedance in the L2N loop, using the zero sequence current compensation factor for zone 1
RL3+j XL3	ohm	Measured positive sequence impedance in the L3N loop, using the zero sequence current compensation factor for zone 1
RL1L2+j XL1L2	ohm	Measured positive sequence impedance in the L1L2 loop
RL2L3+j XL2L3	ohm	Measured positive sequence impedance in the L2L3 loop
RL3L1+j XL3L1	ohm	Measured positive sequence impedance in the L3L1 loop

Table 1-5 The measured (calculated) values of the Z_CALC module

Z_CALC includes six practically identical software modules for impedance calculation:

- The three routines of the phase group are activated by phase voltages, phase currents and the zero sequence current calculated from the phase current and the zero sequence currents of the parallel line, as measured in a dedicated input.
- The three routines for the phase-to-phase loops get line-to-line voltages calculated from the sampled phase voltages and they get differences of the phase currents. They do not need zero sequence currents for the calculation.

The calculated impedances are analogue outputs of the distance protection function. They serve the purpose of checking possibility at commissioning.

4.1.2.2.4. Internal logic of the impedance calculation

Fig. 1-3 shows the internal logic of the impedance calculation.

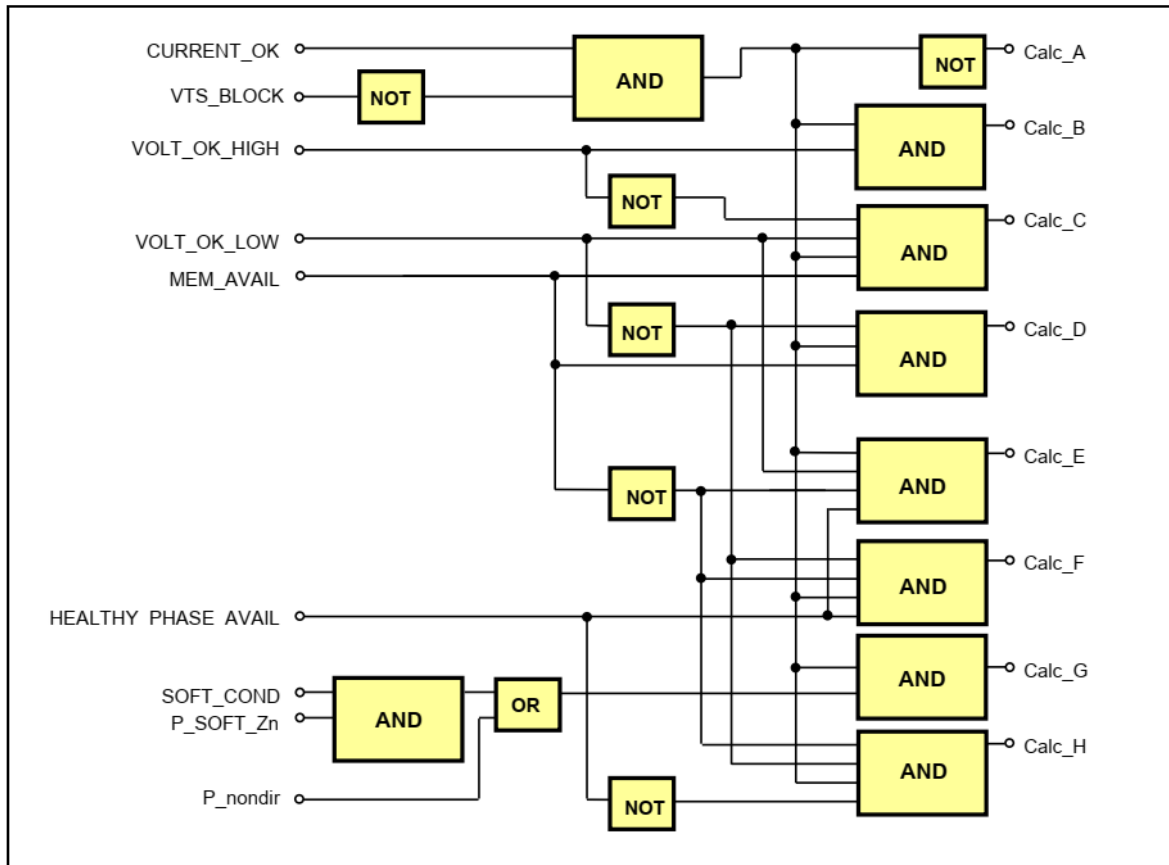

Figure 1-2 Z_CALC internal logic

The decision needs logic parameter settings and, additionally, internal logic signals. The explanation of these signals is as follows:

Parameter	Explanation
P_SOTF_Zn	This logic parameter is true if the “switch-onto-fault” logic is enabled for Zone_n, (where n=1...5), i.e., DIS21_SOTFmd_EPar_ (SOTF Zone) is selected for “Zone n” (where n=1...5).
P_nondir	This logic parameter is true if offset MHO is programmed, i.e., the DIS21_Zn_EPar_ (Operation Zonen) parameter (where n=1...5) is set to “Offset” for the individual zones.

Table 1-6 Enumerated parameters for the Z_CALC module

Input status signal	Explanation
CURRENT_OK	The current is suitable for impedance calculation in the processed loop if, after a zero crossing, there are three sampled values above a defined limit ($\sim 0.1I_n$). For a phase-ground loop calculation, it is also required that the sum of the phase current ($3I_o$) should be above $I_{phase}/4$. This status signal is generated within the <i>Z_CALC</i> module based on the parameter <i>DIS21_Imin_IPar_</i> (I minimum) and in case of phase-ground loops on parameters <i>DIS21_IoBase_IPar_</i> (Io Base sens.) and <i>DIS21_IoBias_IPar_</i> (Io Bias)
VTS Block	Binary blocking signal due to error in the voltage measurement
VOLT_OK_HIGH	The voltage is suitable for the calculation if the most recent ten sampled values include a sample above the defined limit (35% of the nominal loop voltage). This status signal is generated within the <i>Z_CALC</i> module.
VOLT_OK_LOW	The voltage can be applied for the calculation of the impedance if the three most recent sampled three values include a sample above the defined lower limit (5% of the nominal loop voltage), but in this case the direction is to be decided using the voltage samples stored in the memory because the secondary swings of the capacitive voltage divider distort the sampled voltage values. Below this level, the direction is decided based on the sign either of the real part of the impedance or that of the imaginary part of the impedance, whichever is higher. This status signal is generated within the <i>Z_CALC</i> module.
MEM_AVAIL	This status signal is true if the voltage memory is filled up with available samples above the defined limit for 80 ms. This status signal is generated within the <i>Z_CALC</i> module.
HEALTHY_PHASE_AVAIL	This status signal is true if there are healthy phase voltages (in case of asymmetrical faults) that can be applied to directional decision. This status signal is generated within the <i>Z_CALC</i> module.
SOTF_COND	This status signal is true if the algorithm detected switch-onto-fault conditions, and the binary input signal <i>DIS21_SOTFCond_GrO_</i> (SOTF COND.) is programmed by the user to logic "1", using the graphic equation editor.

Table 1-7 Binary signals for the *Z_CALC* module

The outputs of the scheme of Figure 1-2 are calculation methods applied for impedance calculation for the individual zones.

Calculation method	Explanation
Calc(A)	No current is available, the impedances are supposed to be higher than the possible maximum setting values $R=1000000$ mohm, $X=1000000$ mohm
Calc(B)	The currents and voltages are suitable for the correct impedance calculation and directional decision $R, X=f(u, i)$
Calc(C)	The currents are suitable but the voltages are in the range of the CVT swings, so during the first 35 ms the directional decision is based on pre-fault voltages stored in the memory $R, X=f(u, i)$ direction = $f(U_{mem}, i)$ /in the first 35 ms/ $R, X=f(u, i)$ direction = $f(u, i)$ /after 35 ms/
Calc(D)	The currents are suitable but the voltages are too low. The directional decision is based on pre-fault voltages stored in the memory $R, X=f(u, i)$ direction = $f(\max\{R(U_{mem}, i), X(U_{mem}, i)\})$
Calc(E)	The currents are suitable but the voltages are in the range of the CVT swings and there are no healthy voltages stored in the memory but because of asymmetrical faults, there are healthy voltages. Therefore, during the first 35 ms the directional decision is based on healthy voltages $R, X=f(u, i)$ direction = $f(U_{healthy}, i)$ /in the first 35 ms/ $R, X=f(u, i)$ direction = $f(u, i)$ /after 35 ms/
Calc(F)	The currents are suitable but the voltages are too low, there are no pre-fault voltages stored in the memory but because of asymmetrical faults, there are healthy voltages. Therefore, the directional decision is based on healthy voltages $R, X=f(u, i)$ direction = $f(U_{healthy}, i)$
Calc(G)	If no directional decision is required or in case of prescribed SOTF logic the fault was caused by a switching, then the decision is based on the absolute value of the impedance (forward fault is supposed) $R=abs(R), X=abs(X)$
Calc(H)	If the decision is not possible (no voltage, no pre-fault voltage, no healthy phase voltage but directional decision is required), then the impedance is set to a value above the possible impedance setting $R=1000500$ mohm, $X=1000500$ mohm

Table 1-8 Calculation methods applied in the Z_CALC module

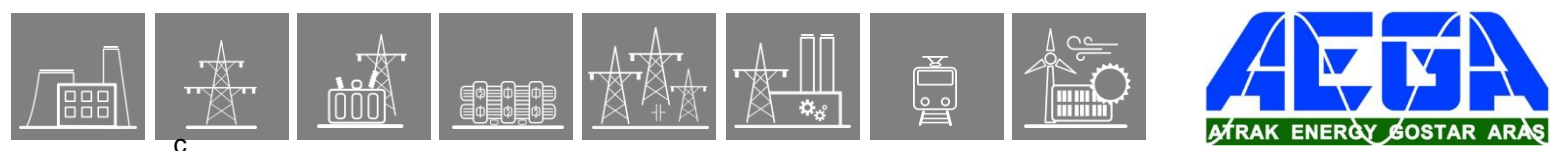

4.1.2.2.5. The impedance calculation methods

The short explanation of the internal logic for the impedance calculation is as follows:

Calculation method Calc(A):

If the CURRENT_OK status signal is false, the current is very small, therefore no fault is possible. In this case, the impedance is set to extreme high values and no further calculation is performed:

$$R=1000000, X=1000000.$$

The subsequent decisions are performed if the current is sufficient for the calculation.

Calculation method Calc(B):

If the CURRENT_OK status signal is true and the VOLT_OK_HIGH status signal is true as well, then the current is suitable for calculation and the voltage is sufficient for the directionality decision. In this case, normal impedance calculation is performed based on the sampled currents and voltages. (The calculation method - the function "f" - is explained later.)

$$R, X=f(u, i)$$

Calculation method Calc(C):

If the CURRENT_OK status signal is true but the VOLT_OK_HIGH status signal is false or there are voltage swings, the directionality decision cannot be performed based on the available voltage signals temporarily. In this case, if the voltage is above a minimal level (in the range of possible capacitive voltage transformer swings), then the VOLT_OK_LOW status is "true", the magnitude of R and X is calculated based on the actual currents and voltages but the direction of the fault (the +/- sign of R and X) must be decided based on the voltage value stored in the memory 80 ms earlier. (The high voltage level setting assures that during the secondary swings of the voltage transformers, no distorted signals are applied for the decision). This procedure is possible only if there are stored values in the memory for 80 ms and these values were sampled during a healthy period.

$$R, X=f(u, i) \quad \text{direction} = f(U_{\text{mem}}, i) \text{ /in the first 35 ms/}$$

After 35 ms (when the secondary swings of the voltage transformers decayed), the directional decision returns to the measured voltage signal again:

$$R, X=f(u, i) \quad \text{direction} = f(u, i) \text{ /after 35 ms/}$$

Calculation method Calc(D):

If the voltage is below the minimal level, then the VOLT_OK_LOW status is "false" but if there are voltage samples stored in the memory for 80 ms, then the direction is decided based on the sign either of the real part of the impedance or that of the imaginary part of the impedance, whichever is higher.

$$R, X=f(u, i) \quad \text{direction} = f(\max\{R(U_{\text{mem}}, i), X(U_{\text{mem}}, i)\})$$



C

Calculation method Calc(E):

The currents are suitable but the voltages are in the range of the CVT swings, there are no pre-fault voltages stored in the memory but because of asymmetrical faults, there are healthy phase voltages. Therefore, during the first 35 ms the directional decision is based on healthy voltages

$$\begin{aligned} R, X=f(u, i) & \quad \text{direction} = f(U_{\text{healthy}}, i) \text{ /in the first 35 ms/} \\ R, X=f(u, i) & \quad \text{direction} = f(u, i) \text{ /after 35 ms/} \end{aligned}$$

This directional decision is based on a special voltage compensation method. The product of the Fourier components of the phase currents and the highest zone impedance setting value is composed. These compensated voltage values are first subtracted from the corresponding phase voltages. If the phase sequence of these resulting voltages is (L1,L3, L2), the fault is in the forward direction. The reverse direction is decided based on the compensated voltages added to the corresponding phase voltages. If this resulting phase sequence is (L1,L3, L2), the fault is in the backward direction. If both phase sequences are (L1, L2, L3), the direction of the fault is undefined.

Calculation method Calc(F):

The currents are suitable but the voltages are too low, there are no pre-fault voltages stored in the memory but because of asymmetrical faults, there are healthy voltages. Therefore, the directional decision is based on healthy voltages

$$R, X=f(u, i) \quad \text{direction} = f(U_{\text{healthy}}, i)$$

The directional decision is described in calculation method Calc(E).

Calculation method Calc(G):

If no directional decision is required or in case of prescribed SOTF logic and the fault was caused by a switching, then the decision is based on the absolute value of the impedance (forward fault is supposed)

$$R=\text{abs}(R), \quad X=\text{abs}(X)$$

Calculation method Calc(H):

If the voltage is not sufficient for a directional decision and no stored voltage samples are available, and if the "switch-onto-fault" logic is not enabled, then the impedance is set to a high value:

$$R=1000500, \quad X=1000500$$

4.1.2.3. The MHO characteristics (MHO)

4.1.2.3.1. Impedance characteristics of the distance protection

The calculated R_1 and $X_1=\omega L_1$ co-ordinate values define six points on the complex impedance plane for the six possible measuring loops. These impedances are the positive sequence impedances. The protection compares these points with the MHO characteristics of the distance protection, shown in Figure 1-3.

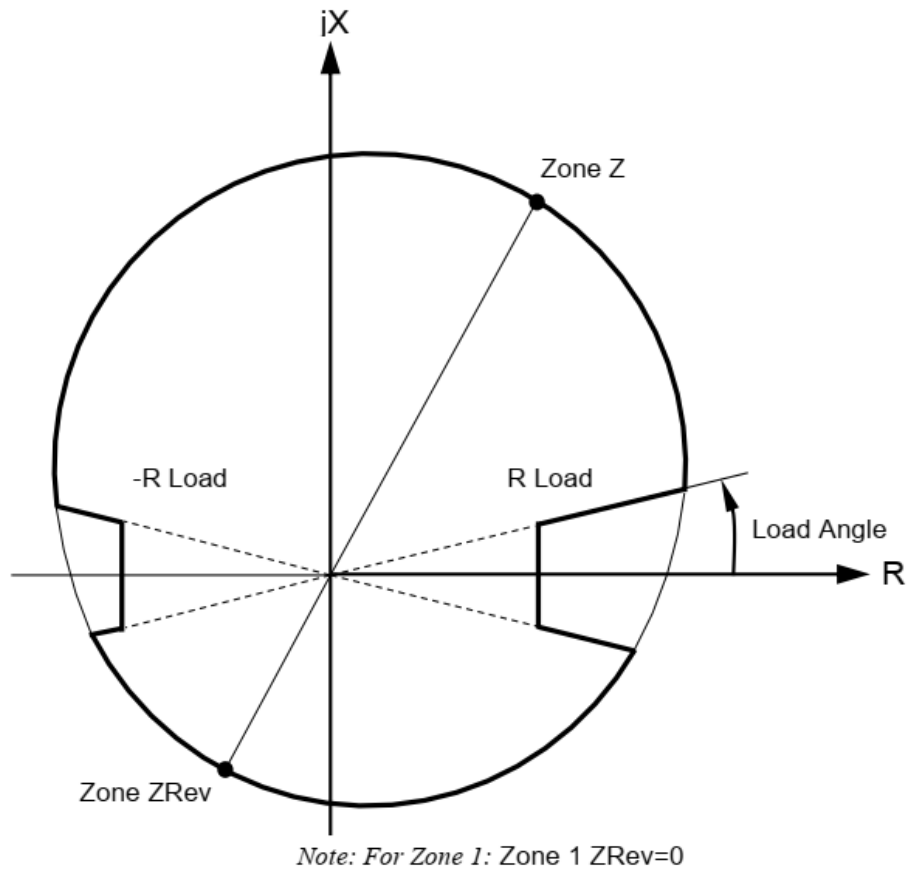

Figure 1-3 The MHO characteristics of the distance protection function on the complex plane

If a measured impedance point is inside the MHO circle, the algorithm generates the true value of the related output binary signal.

The calculated impedance values are compared one by one with the setting values of the MHO characteristics. This procedure is shown schematically in Figure 1-4.

The procedure is processed for each line-to-ground loop and for each line-to-line loop. Then this is repeated for all five impedance stages. The result is the setting of 6 x 5 status variables, which indicate that the calculated impedance is within the processed MHO circle, meaning that the impedance stage has started.

C

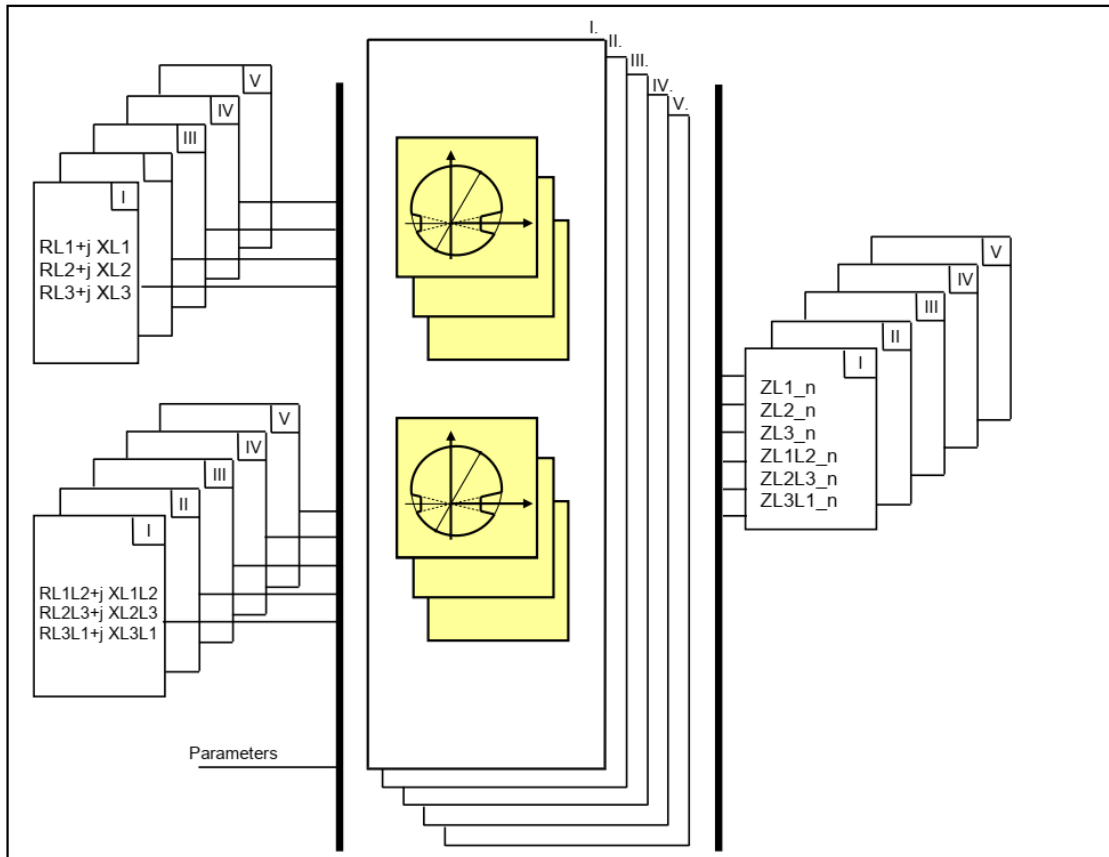

Figure 1-4 MHO logic

C

Input values

The input values are calculated by the module Z_CALC.

Input values	Zones	Explanation
RL1+j XL1	1...5	Calculated impedance in the fault loop L1N using parameters of the zones individually
RL2+j XL2	1...5	Calculated impedance in the fault loop L2N using parameters of the zones individually
RL3+j XL3	1...5	Calculated impedance in the fault loop L3N using parameters of the zones individually
RL1L2+j XL1L2	1...5	Calculated impedance in the fault loop L1L2 using parameters of the zones individually
RL2L3+j XL2L3	1...5	Calculated impedance in the fault loop L2L3 using parameters of the zones individually
RL3L1+j XL3L1	1...5	Calculated impedance in the fault loop L3L1 using parameters of the zones individually

Table 1-9 The input impedances of the MHO module

Output values

Output values	Zones	Explanation
ZL1_n	1...5	The impedance in the fault loop L1N is inside the MHO characteristics
ZL2_n	1...5	The impedance in the fault loop L2N is inside the MHO characteristics
ZL3_n	1...5	The impedance in the fault loop L3N is inside the MHO characteristics
ZL1L2_n	1...5	The impedance in the fault loop L1L2 is inside the MHO characteristics
ZL2L3_n	1...5	The impedance in the fault loop L2L3 is inside the MHO characteristics
ZL3L1_n	1...5	The impedance in the fault loop L3L1 is inside the MHO characteristics

Table 1-10 The output status signals of the MHO module

The parameters needed in the MHO circle evaluation procedure of the distance protection function are explained in the following tables.

Enumerated parameters

Parameter name	Title	Selection range	Default
Parameters to select directionality of the individual zones:			
DIS21_Z1_EPar_	Operation Zone1	Off, Forward, Backward	Off
DIS21_Z2_EPar_	Operation Zone2	Off, Forward, Backward, Offset	Off
DIS21_Z3_EPar_	Operation Zone3	Off, Forward, Backward, Offset	Off
DIS21_Z4_EPar_	Operation Zone4	Off, Forward, Backward, Offset	Off
DIS21_Z5_EPar_	Operation Zone5	Off, Forward, Backward, Offset	Off

Table 1-11 Enumerated parameters for the MHO logic

Integer parameters

Parameter name	Title	Unit	Min	Max	Step	Default
Definition of the load angle of the polygon characteristic:						
DIS21_LdAng_IPar_	Load Angle	deg	0	45	1	30
Definition of the line angle:						
DIS21_LinAng_IPar_	Line Angle	deg	0	90	1	75

Table 1-12 Integer parameters for the MHO logic

Floating point parameters

Parameter name	Title	Dimension	Min	Max	Default
Setting values of the characteristics for the five zones individually:					
DIS21_Z1X_FPar	Zone1 Z	ohm	0.01	200	10
DIS21_Z2X_FPar	Zone2 Z	ohm	0.01	200	10
DIS21_Z3X_FPar	Zone3 Z	ohm	0.01	200	10
DIS21_Z4X_FPar	Zone4 Z	ohm	0.01	200	10
DIS21_Z5X_FPar	Zone5 Z	ohm	0.01	200	10
DIS21_Z2R_FPar	Zone2 ZRev**	ohm	0.01	200	10
DIS21_Z3R_FPar	Zone3 ZRev**	ohm	0.01	200	10
DIS21_Z4R_FPar	Zone4 ZRev**	ohm	0.01	200	10
DIS21_Z5R_FPar	Zone5 ZRev**	ohm	0.01	200	10
DIS21_LdR_FPar	R Load	ohm	0.01	200	10

** Active only if "Operation Zone 2...5" is set to "Offset". Zone 1 can not be set for offset characteristics.

Table 1-13 Floating point parameters for the MHO logic

4.1.2.4. The phase selection logic (SELECT) and timing

In case of faults, the calculated impedance value for the faulty loop is inside a MHO circle. If the fault is near the relay location, the impedances in the loop containing the faulty phase can also be inside the characteristic circle. To ensure selective tripping, phase selection is needed. This chapter explains the operation of the phase selection logic.

The **binary inputs** are signals influencing the operation of the distance protection function. These signals are the results of logic equations graphically edited by the user.

Binary input signals	Signal title	Explanation
DIS21_Z1Bik_GrO_	Block Z1	Blocking of Zone 1
DIS21_Z2Bik_GrO_	Block Z2	Blocking of Zone 2
DIS21_Z3Bik_GrO_	Block Z3	Blocking of Zone 3
DIS21_Z4Bik_GrO_	Block Z4	Blocking of Zone 4
DIS21_Z5Bik_GrO_	Block Z5	Blocking of Zone 5
DIS21_SOTFCond_GrO_	SOTF COND.	Status signal indicating switching-onto-fault condition

Table 1-14 Binary input signals influencing the phase selection logic

Binary inputs processed by the “MHO” logic

Binary input signals from MHO logic	Explanation
ZL1_n	The calculated impedance for loop L1 is inside the circle of Zone “n” (n=1...5)
ZL2_n	The calculated impedance for loop L2 is inside the circle of Zone “n” (n=1...5)
ZL3_n	The calculated impedance for loop L3 is inside the circle of Zone “n” (n=1...5)
ZL1L2_n	The calculated impedance for loop L1L2 is inside the circle of Zone “n” (n=1...5)
ZL2L3_n	The calculated impedance for loop L2L3 is inside the circle of Zone “n” (n=1...5)
ZL3L1_n	The calculated impedance for loop L3L1 is inside the circle of Zone “n” (n=1...5)

Table 1-15 Binary input signals from the MHO logic

C

Timer parameters

Parameter name	Title	Unit	Min	Max	Step	Default
Time delay for the zones individually						
DIS21_Z1Del_TPar_	Zone1 Time Delay	ms	0	60000	1	0
DIS21_Z2Del_TPar_	Zone2 Time Delay	ms	0	60000	1	400
DIS21_Z3Del_TPar_	Zone3 Time Delay	ms	0	60000	1	800
DIS21_Z4Del_TPar_	Zone4 Time Delay	ms	0	60000	1	2000
DIS21_Z5Del_TPar_	Zone5 Time Delay	ms	0	60000	1	2000

Table 1-19 Timer parameters of the distance protection function

4.1.2.4.1. Three phase fault detection

The processing of diagrams in the following figures is sequential. If the result of one of them is true, no further processing is performed.

Figure 1-5 shows that if

- all three line-line loops of the MHO impedance logic have stated and
- the currents in all three phases are above the setting limit,

then a three-phase fault is detected and no further check is performed. The three-phase fault detection resets only if none of the three line-to-line loops detect fault any longer.

In Figure 1-5 and in the subsequent figures “n = 1...5” means that the logic is repeated for all five zones.

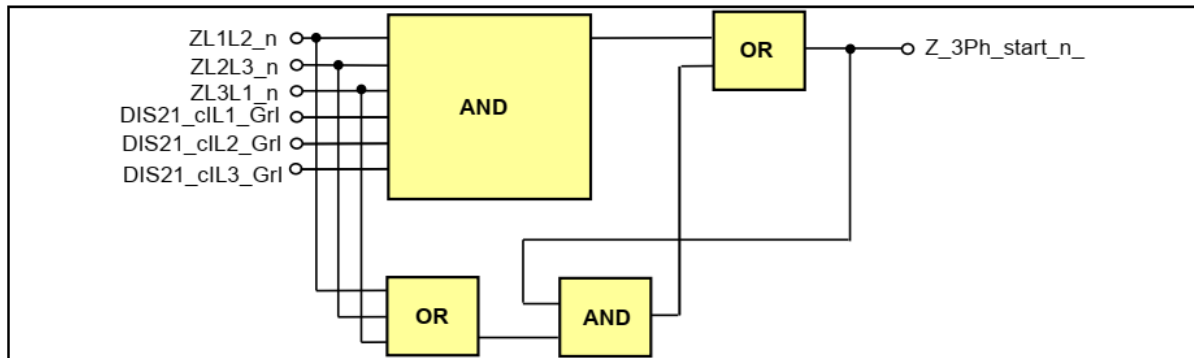

Figure 1-5 Three-phase fault detection in Zone “n” (n=1...5)

Output status signals	Zones	Explanation
Z_3Ph_start_n	n=1...5	Three-phase start of the distance protection function in zone “n”

Table 1-20 Three-phase start of the distance protection function

C

Input status signals	Zones	Explanation
ZL1L2_n	n=1...5	The calculated impedance of fault loop L1L2 is within the zone characteristic
ZL2L3_n	n=1...5	The calculated impedance of fault loop L2L3 is within the zone characteristic
ZL3L1_n	n=1...5	The calculated impedance of fault loop L3L1 is within the zone characteristic
DIS21_cIL1_GrI	n=1...5	The current in phase L1 is sufficient for impedance calculation
DIS21_cIL2_GrI	n=1...5	The current in phase L2 is sufficient for impedance calculation
DIS21_cIL3_GrI	n=1...5	The current in phase L3 is sufficient for impedance calculation

Table 1-21 Inputs needed to decide the three-phase start of the distance protection function

4.1.2.4.2. Detection of “L1L2”, “L2L3”, “L3L1” faults

Figure 1-6 explains the detection of a phase-to-phase fault between phases “L1” and “L2”:

- no fault is detected in the previous sequential tests,
- the start of the MHO impedance logic in loop “L1L2” and loop “L1L2” detects the lowest reactance, and
- “OR” relation of the following logic states:
 - no zero sequence current above the limit and no start of the MHO logic in another phase-to-phase loop, or
 - in the presence of a zero sequence current
 - start of the MHO impedance logic in loops “L1” and ”L2” individually as well, or
 - the voltage is small in the faulty “L1L2” loop and the currents in both phases involved are above the setting limit.

The “L1L2” fault detection resets only if none of the “L1L2” line-to-line, “L1N” or “L2N” loops detect fault any longer.

In Figures Figure 1-6, Figure 1-7 and Figure 1-8:

$$\text{minLL} = \text{Minimum}(\text{ZL1L2}, \text{ZL2L3}, \text{ZL3L1})$$

C

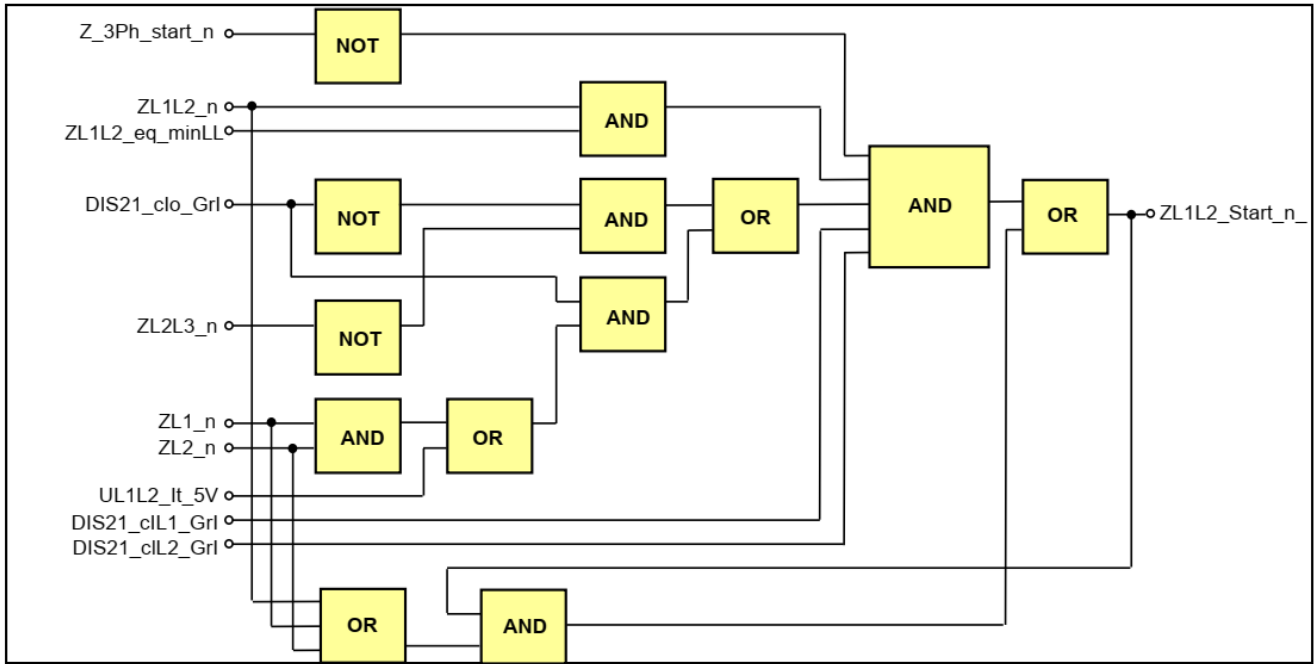

Figure 1-6 L1L2 fault detection in Zone “n” (n=1...5)

Figure 1-7 and Figure 1-8 show a similar logic for loops “L2L3” and “L3L1”, respectively.

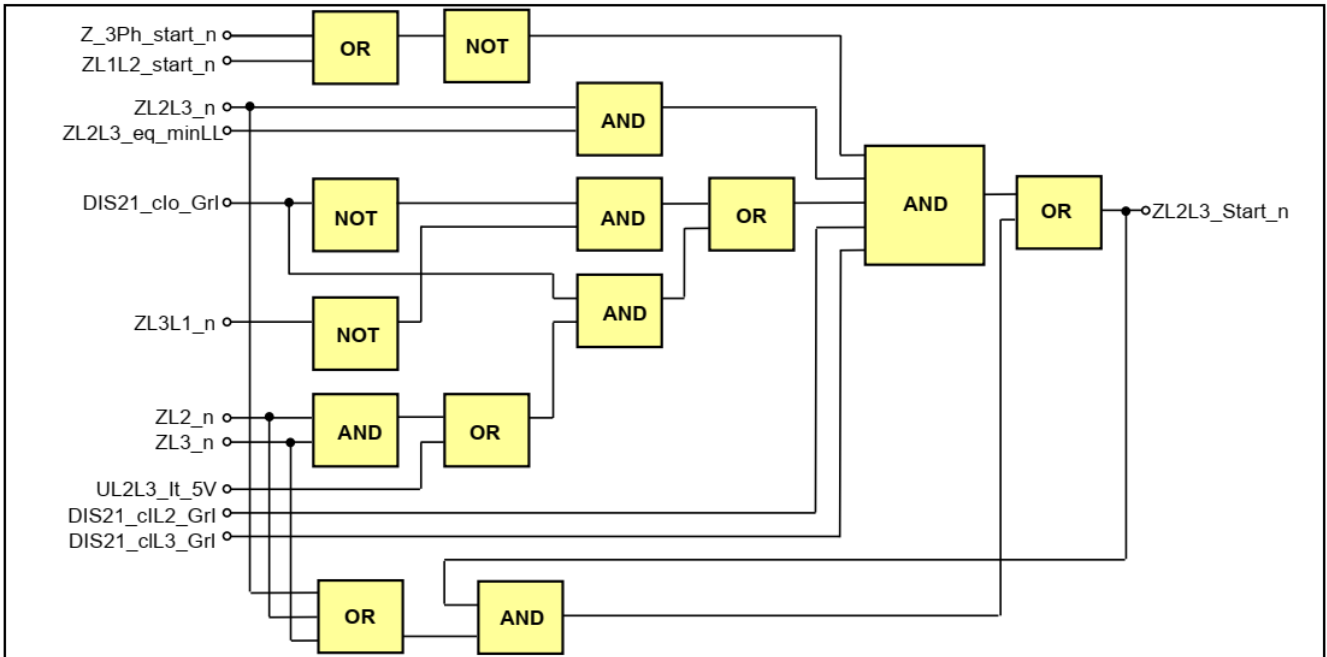

Figure 1-7 L2L3 fault detection in Zone “n” (n=1...5)

C

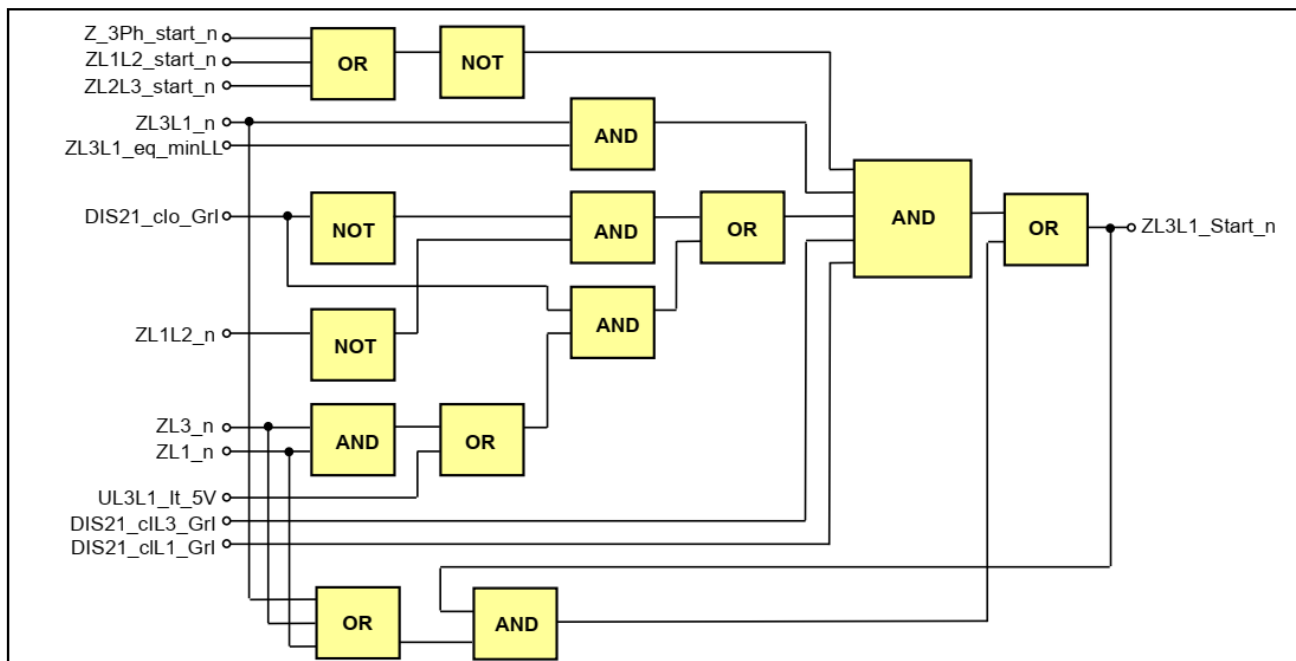

Figure 1-8 L3L1 fault detection in Zone “n” (n=1...5)

Output status signals	Zones	Explanation
L1L2_Start_n	n=1...5	L1L2 loop start of the distance protection function in zone “n”
L2L3_Start_n	n=1...5	L2L3 loop start of the distance protection function in zone “n”
L3L1_Start_n	n=1...5	L3L1 loop start of the distance protection function in zone “n”

Table 1-22 Phase-to-phase loop start of the distance protection function

Input status signals	Zones	Explanation
Z_3Ph_start_n	n=1...5	Outputs of the previous decisions
ZL1L2_Start_n	n=1...5	Outputs of the previous decisions
ZL2L3_Start_n	n=1...5	Outputs of the previous decisions
ZL1L2_n	n=1...5	The calculated impedance of fault loop L1L2 is within the zone characteristic
ZL2L3_n	n=1...5	The calculated impedance of fault loop L2L3 is within the zone characteristic
ZL3L1_n	n=1...5	The calculated impedance of fault loop L3L1 is within the zone characteristic
ZL1L2_equ_minLL	n=1...5	The calculated impedance of fault loop L1L2 is the smallest one
ZL2L3_equ_minLL	n=1...5	The calculated impedance of fault loop L2L3 is the <u>smallest one</u>
ZL3L1_equ_minLL	n=1...5	The calculated impedance of fault loop L3L1 is the <u>smallest one</u>
ZL1_n	n=1...5	The calculated impedance of fault loop L1N is within the zone characteristic
ZL2_n	n=1...5	The calculated impedance of fault loop L2N is within the zone characteristic
ZL3_n	n=1...5	The calculated impedance of fault loop L3N is within the zone characteristic
DIS21_cIL1_Grl		The current in phase L1 is sufficient for impedance calculation
DIS21_cIL2_Grl		The current in phase L2 is sufficient for impedance calculation
DIS21_cIL3_Grl		The current in phase L3 is sufficient for impedance calculation
DIS21_cIo_Grl_		The zero sequent current component is sufficient for earth fault calculation
UL1L2_Lt_5V		The L1L2 voltage is less than 5V
UL3L3_Lt_5V		The L2L3 voltage is less than 5V
UL3L2_Lt_5V		The L3L1 voltage is less than 5V

Table 1-23 Inputs needed to decide phase-to-phase loop start of the distance protection function

4.1.2.4.3. Detection of “L1N”, “L2N”, “L3N” faults

Figure 1-9 explains the detection of a phase-to-ground fault in phase “L1”:

- no fault is detected in the previous sequential tests,
- start of the MHO impedance logic in loop “L1N”,
- the minimal impedance is measured in loop “L1N”,
- no start of the MHO logic in another phase-to-ground loop,
- the zero sequence current above the limit,
- the current in the phase involved is above the setting limit,
- the minimal impedance of the phase-to-ground loops is less then the minimal impedance in the phase-to-phase loops.

In Figure 1-9, Figure 1-10 and Figure 1-11:

$$\text{minLN} = \text{Minimum}(ZL1N, ZL2N, ZL3N)$$

C

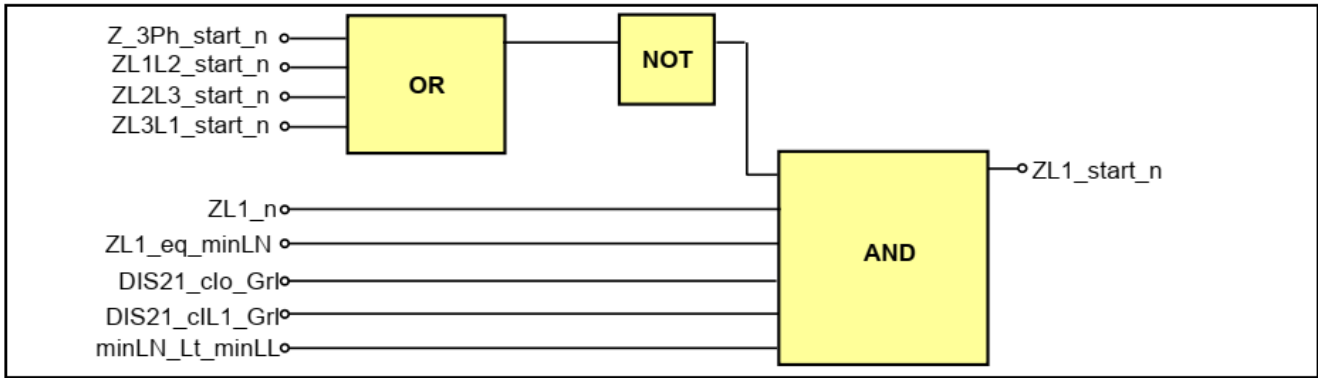

Figure 1-9 L1N fault detection in Zone “n” (n=1...5)

Figure 1-10 and Figure 1-11 show similar logic for loops “L2” and “L3” respectively.

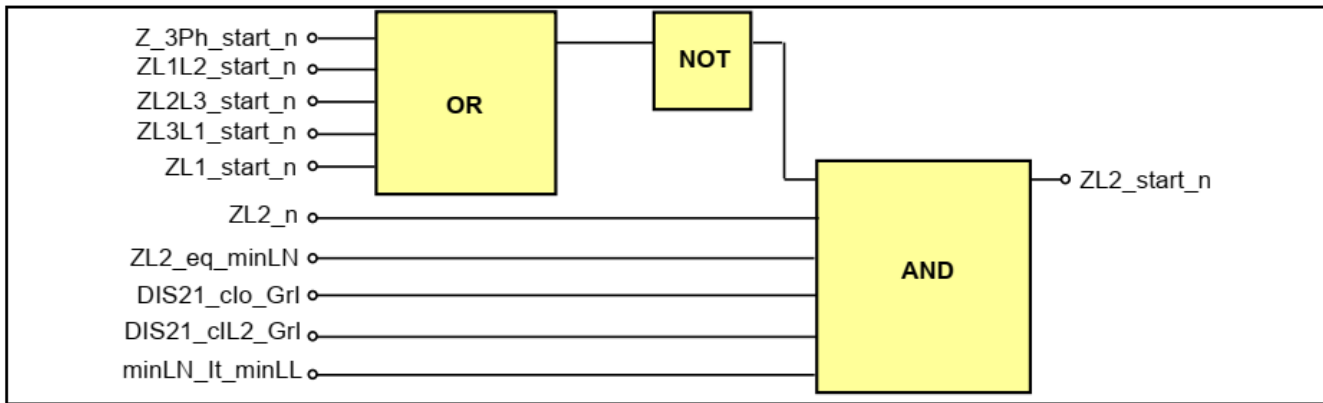

Figure 1-10 L2N fault detection in Zone “n” (n=1...5)

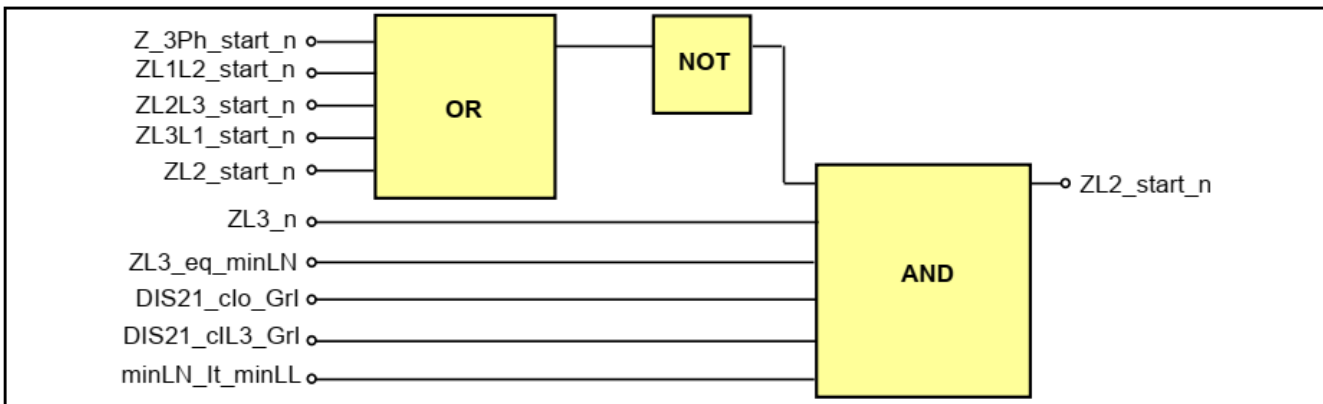

Figure 1-11 L3N fault detection in Zone “n” (n=1...5)

Output status signals	Zones	Explanation
ZL1_Start_n	n=1...5	L1N loop start of the distance protection function in zone “n”
ZL2_Start_n	n=1...5	L2N loop start of the distance protection function in zone “n”
ZL3_Start_n	n=1...5	L3N loop start of the distance protection function in zone “n”

Table 1-24 Phase-to-ground loop start of the distance protection function

Input status signals	Zones	Explanation
ZL1L2_Start_n	n=1...5	Outputs of the previous decisions
ZL2L3_Start_n	n=1...5	Outputs of the previous decisions
ZL3L1_Start_n	n=1...5	Outputs of the previous decisions
ZL1_Start_n	n=1...5	Outputs of the previous decisions
ZL2_Start_n	n=1...5	Outputs of the previous decisions
ZL1_equ_minLN	n=1...5	The calculated impedance of fault loop L1 is the smallest one
ZL2_equ_minLN	n=1...5	The calculated impedance of fault loop L2 is the smallest one
ZL3_equ_minLN	n=1...5	The calculated impedance of fault loop L3 is the smallest one
ZL1_n	n=1...5	The calculated impedance of fault loop L1N is within the zone characteristic
ZL2_n	n=1...5	The calculated impedance of fault loop L2N is within the zone characteristic
ZL3_n	n=1...5	The calculated impedance of fault loop L3N is within the zone characteristic
DIS21_cIL1_Grl	n=1...5	The current in phase L1 is sufficient for impedance calculation
DIS21_cIL2_Grl	n=1...5	The current in phase L2 is sufficient for impedance calculation
DIS21_cIL3_Grl	n=1...5	The current in phase L3 is sufficient for impedance calculation
DIS21_cIo_Grl	n=1...5	The zero sequence current component is sufficient for impedance calculation in LN loops

Table 1-25 Inputs needed to decide Phase-to-ground loop start of the distance protection function

C

Figure 1-12 shows how the signals are processed for the output signals of the distance protection function.

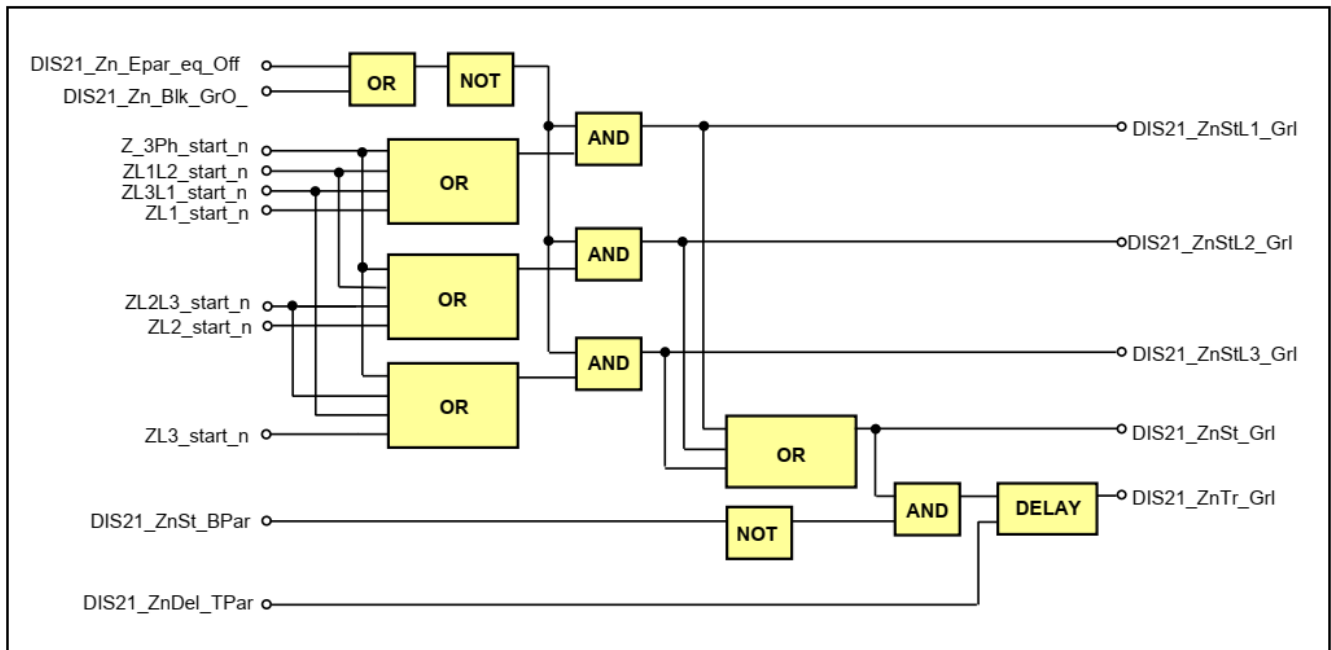

Figure 1-12 Output signals of the distance protection function for Zone "n" (n=1...5)

- The operation of the distance protection may be blocked either by parameter setting (DIS21_Zn_EPar_eq_Off) or by binary input (DIS21_Zn_BlK_GrO_)
- Starting in phase L1 if this phase is involved in the fault (DIS21_ZnStL1_Grl),
- Starting in phase L2 if this phase is involved in the fault (DIS21_ZnStL2_Grl),
- Starting in phase L2 if this phase is involved in the fault (DIS21_ZnStL3_Grl),
- General start if any of the phases is involved in the fault (DIS21_ZnSt_Grl),
- A trip command (DIS21_ZnTr_Grl) is generated after the timer Zn_Delay has expired. This timer is started if the zone is started and it is not assigned to "Start signal only", using the parameter DIS21_ZnSt_BPar. The time delay is set by the timer parameter DIS21_ZnDel_TPar.

Figure 1-13 shows the method of post-processing the binary output signals to generate general start signals for the phases individually and separately for zones 2 to 5.

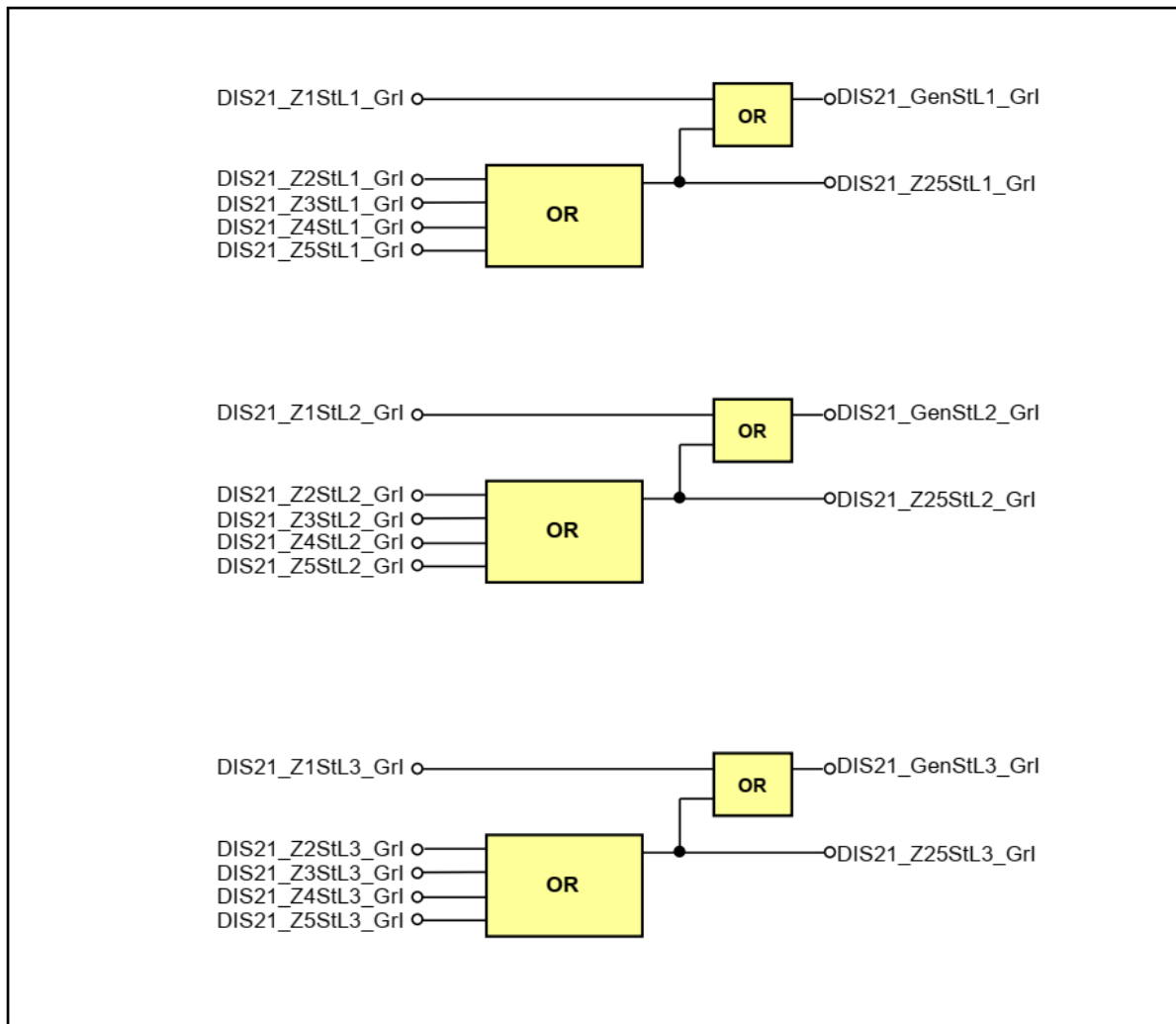

Figure 1-13 General start in the phase-to-ground loops separately for Zones 2 to 5

The binary output status signals of the distance protection function.

Binary output signals	Signal title	Explanation
Distance Phase identification		
DIS21_GenStL1_GrL_	GenStart L1	General start in phase L1
DIS21_GenStL2_GrL_	GenStart L2	General start in phase L2
DIS21_GenStL3_GrL_	GenStart L3	General start in phase L3

Table 1-26 General phase identification of the distance protection function

The separate phase identification signals for Zones 2-5 are not published.

4.1.2.5. The current conditions of the distance protection function (I_COND)

The distance protection function can operate only if the current is sufficient for impedance calculation. Additionally, a phase-to-ground fault is detected only if there is sufficient zero sequence current. This function performs these preliminary decisions.

Binary output signals	Signal title	Explanation
Distance function start conditions generated by the I_COND module (these signals are not published)		
DIS21_clo_Grl_	Io condition	The zero sequent current component is sufficient for earth fault calculation
DIS21_cIL1_Grl_	I L1 condition	The current in phase L1 is sufficient for impedance calculation
DIS21_cIL2_Grl_	I L2 condition	The current in phase L2 is sufficient for impedance calculation
DIS21_cIL3_Grl_	I L3 condition	The current in phase L3 is sufficient for impedance calculation

Table 1-27 The binary output status signals of the current conditions module

Integer parameters

Parameter name	Title	Unit	Min	Max	Step	Default
Definition of minimal current enabling impedance calculation:						
DIS21_lmin_IPar_	I Ph Base Sens	%	10	30	1	20
Definition of zero sequence current characteristic enabling impedance calculation in phase-to-earth loops:						
DIS21_loBase_IPar_	I Res Base Sens	%	10	50	1	10
DIS21_loBias_IPar_	I Res Bias	%	5	30	1	10

Table 1-28 Integer parameters for the current conditions module

The current is considered to be sufficient for impedance calculation if it is above the level set by parameter DIS21_lmin_IPar_.

To decide the presence or absence of the zero sequence current, biased characteristics are applied (see Figure 1-14). The minimal setting current DIS21_loBase_IPar_ (Io Base sens.) and a percentage biasing DIS21_loBias_IPar_ (I Res bias) must be set. The biasing is applied for the detection of zero sequence current in the case of increased phase currents.

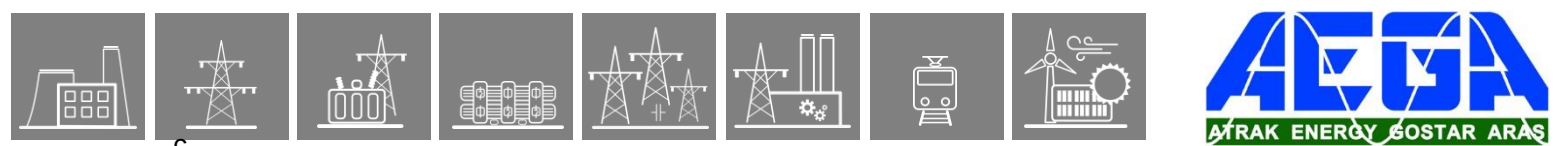

C

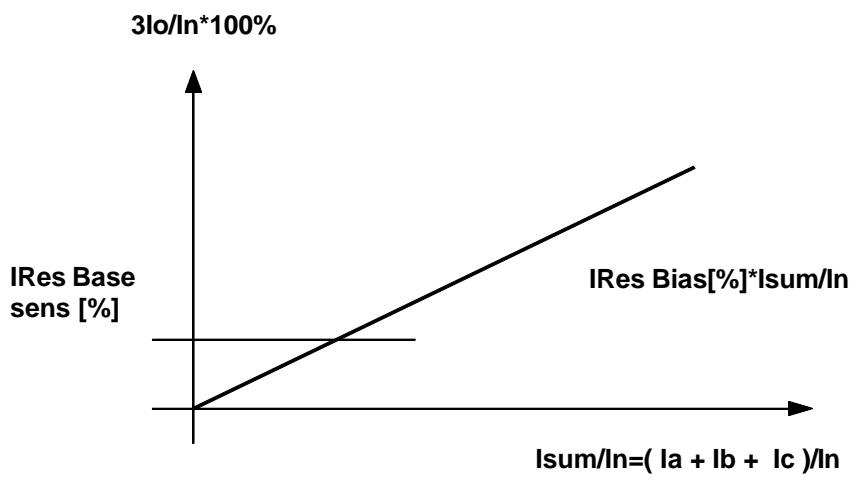
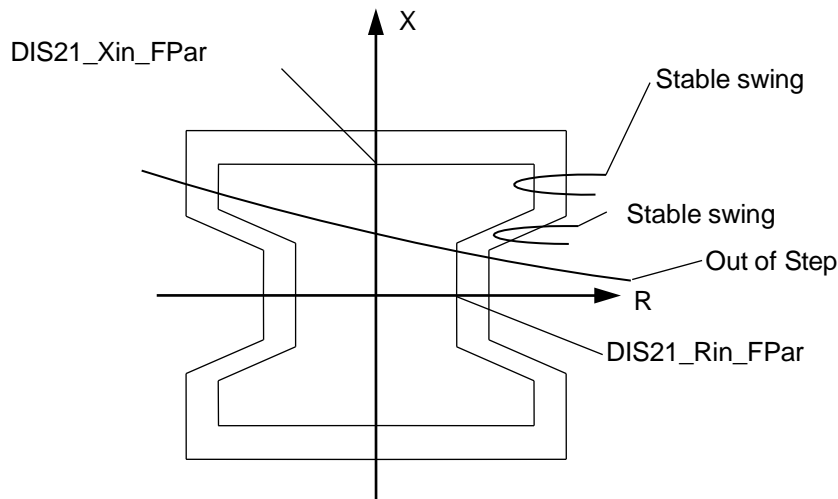

Figure 1-14 Percentage characteristic for earth-fault detection

4.1.2.6. The power swing detection (PSD)

Power swings can be stable or they can result in an out-of-step operation. Accordingly, the power swing detection function can block the distance protection function in case of stable swings, or it can generate a trip command if the system operates out of step (See Figure 1-15).



Ratio of the outer characteristics set by:
 DIS21_RRat_IPar_
 DIS21_XRat_IPar_

Figure 1-15 Characteristics of the out-of-step detection function

The **binary output status signals** of the power swing detection function.

Binary output signals	Signal title	Explanation
Distance function power swing signals generated by the PSD module		
DIS21_PSDDet_Grl_	PSD Detect	Signal for power swing detection
DIS21_OutTr_Grl_	OutOfStep Trip	Signal for out-of-step tripping condition
DIS21_PSDslow_Grl_	VerySlow Swing	Signal for very slow power swing detection

Table 1-29 The binary output status signals of the power swing detection function

All these binary signals can serve as binary inputs for the graphic equations, to be programmed by the user.

The **binary inputs** are signals influencing the operation of the distance protection function. These signals are the results of logic equations graphically edited by the user. E.g., the DIS21_PSDBIk_GrO_ signal can be programmed using these inputs to block the power swing detection.

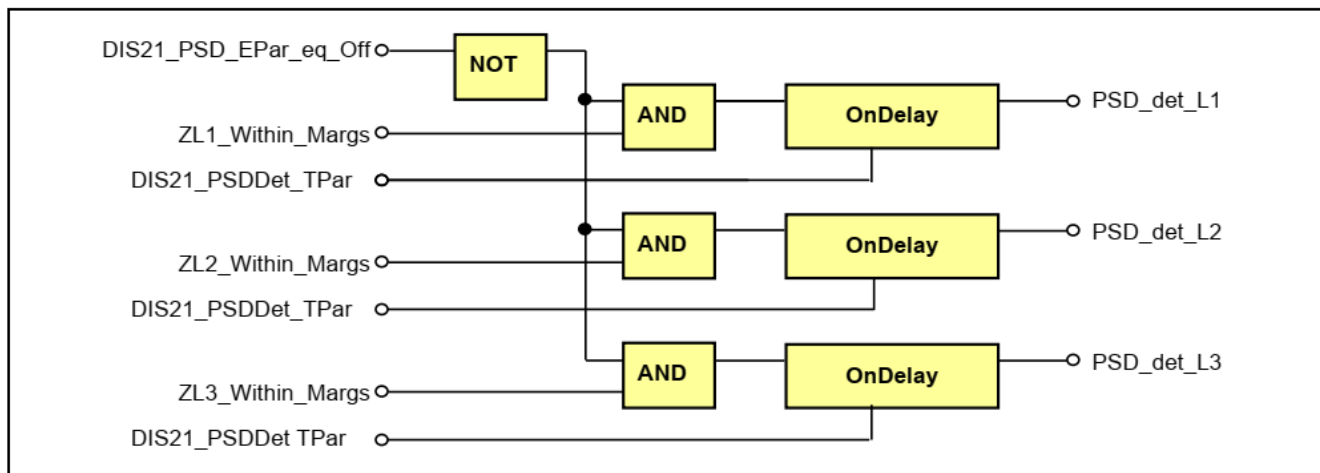

Figure 1-16 Power swing detection in the individual phases

Figure 1-16 shows that power swing is detected in the individual phases if the measured impedance (Phase-to-ground loop for Zone1) is within the margins of the PSD characteristics for the time span, given with parameter DIS21_PSDDel_TPar.

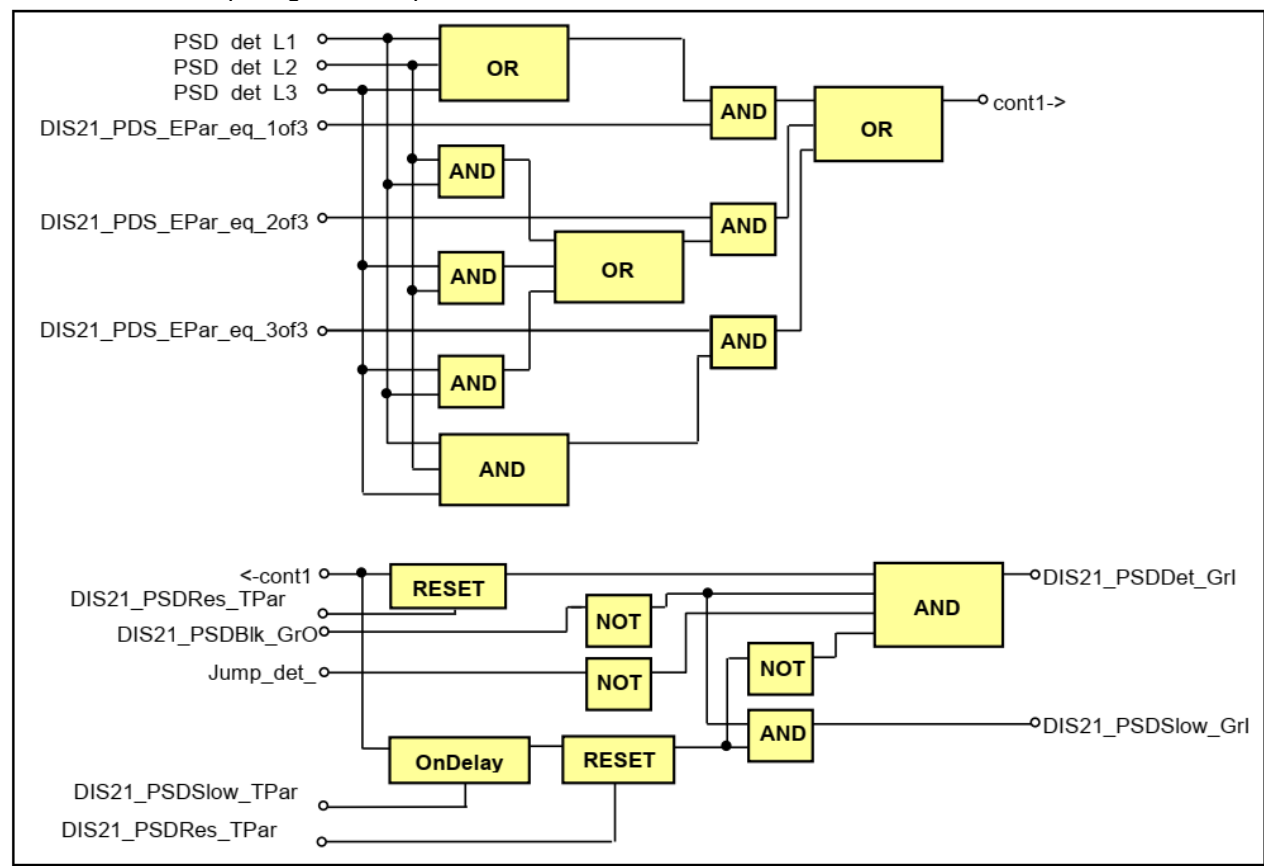

Figure 1-17 Power swing detection and slow power swing detection

According to Figure 1-17, the power swings in the individual phases result in a power swing state only if the combination of the phases corresponds to the parameter setting DIS21_PSD_EPar (which can be 1 out of 3, 2 out of 3, 3 out of 3).

C

In this case, the algorithm can generate the out-of-step tripping condition DIS21_OutTr_GrI_. The duration of this impulse is determined by the parameter DIS21_OutPs_TPar_.

The “very slow swing” condition DIS21_PSDslow_GrI_ is generated if the duration of measuring the impedance within the rectangle is longer then the parameter setting DIS21_PSDslow_TPar_.

All these binary output signals can serve as binary inputs for the graphic equations, to be programmed by the user.

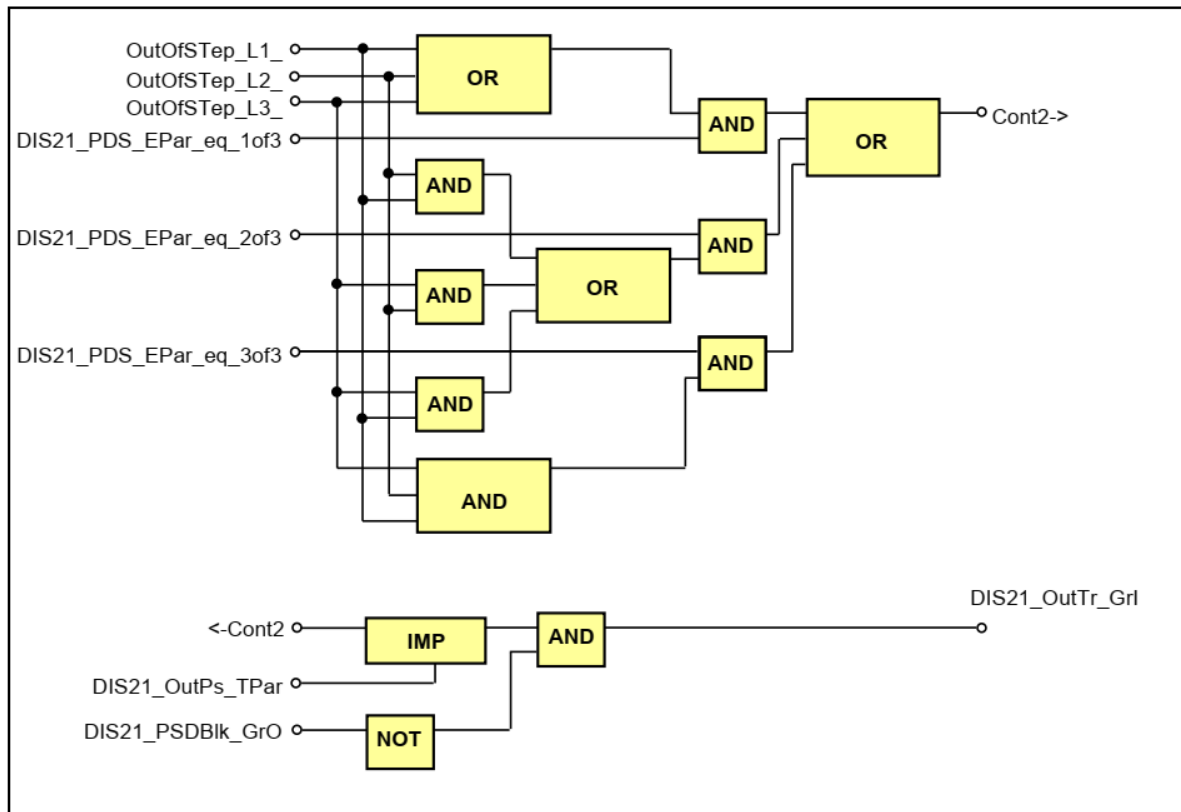

Figure 1-20 Out-of-step trip command generation

According to Figure 1-20, the out-of-step conditions in the individual phases can result in an out-of-step trip command impulse only if the combination of the phases corresponds to the parameter setting DIS21_PSD_EPar (which can be 1 out of 3, 2 out of 3, 3 out of 3).

The duration of the trip command can be set using the parameter DIS21_OutPs_TPar_.



C

4.1.2.7. The distance-to-fault calculation (FAULT LOCATOR)

The distance protection function selects the faulty loop impedance (its positive sequence component) and calculates the distance to fault based on the measured positive sequence reactance and the total reactance of the line. This reference value is given as a parameter setting DIS21_LReact_FPar_. The calculated percentage value facilitates displaying the distance in kilometers if the total length of the line is correctly set by the parameter DIS21_Lgth_FPar_.

Floating point parameters

Parameter name	Title	Dim.	Min	Max	Default
DIS21_Lgth_FPar_	Line Length	km	0.10	1000	100
DIS21_LReact_FPar_	Line Reactance	ohm	0.10	200	10

Table 1-36 The floating point parameters



C

4.1.2.8. The high-speed overcurrent protection function with switch-onto-fault logic (HSOC SOTF)

The switch-onto-fault protection function can generate an immediate trip command if the function is enabled and switch-onto-fault condition is detected. The condition of the operation can be the starting signal of any distance protection zone as it is selected by a dedicated parameter, or it can be the operation of the high-speed overcurrent protection function.

The high-speed overcurrent protection function operates if a sampled value of the phase current is above the setting value.

The **binary output status signals** of SOTF function.

Binary output signals	Signal title	Explanation
SOTF function		
DIS21_SOTFTr_GrI_	SOTF Trip	The distance protection function generated a trip command caused by switching onto fault

Table 1-37 The binary output signals of the SOTF function

The **binary input** is a signal influencing the operation of the distance protection function. This signal is the result of logic equations graphically edited by the user.

Binary input signals	Signal title	Explanation
DIS21_SOTFCond_GrO_	SOTF COND.	Status signal indicating switching-onto-fault condition

Table 1-38 Binary input signals of the SOTF logic

The parameters of the SOTF function are explained in the following tables.

Enumerated parameters

Parameter name	Title	Selection range	Default
Parameter for selecting one of the zones or “high speed overcurrent protection” for the “switch-onto-fault” function:			
DIS21_SOTFMd_EPar _	SOTF Zone	Off,Zone1,Zone2,Zone3,Zone4,Zone5 ,HSOC	Zone1

Table 1-39 The enumerated parameters of the SOTF function

Integer parameters

Parameter name	Title	Unit	Min	Max	Step	Default
Definition of the overcurrent setting for the switch-onto-fault function, for the case where the DIS21_SOTFMd_EPar_ (SOTF Zone) parameter is set to “HSOC”:						
DIS21_SOTFOC_IPar_	SOTF Current	%	10	1000	1	200

Table 1-40 The integer parameters of the SOTF logic

C

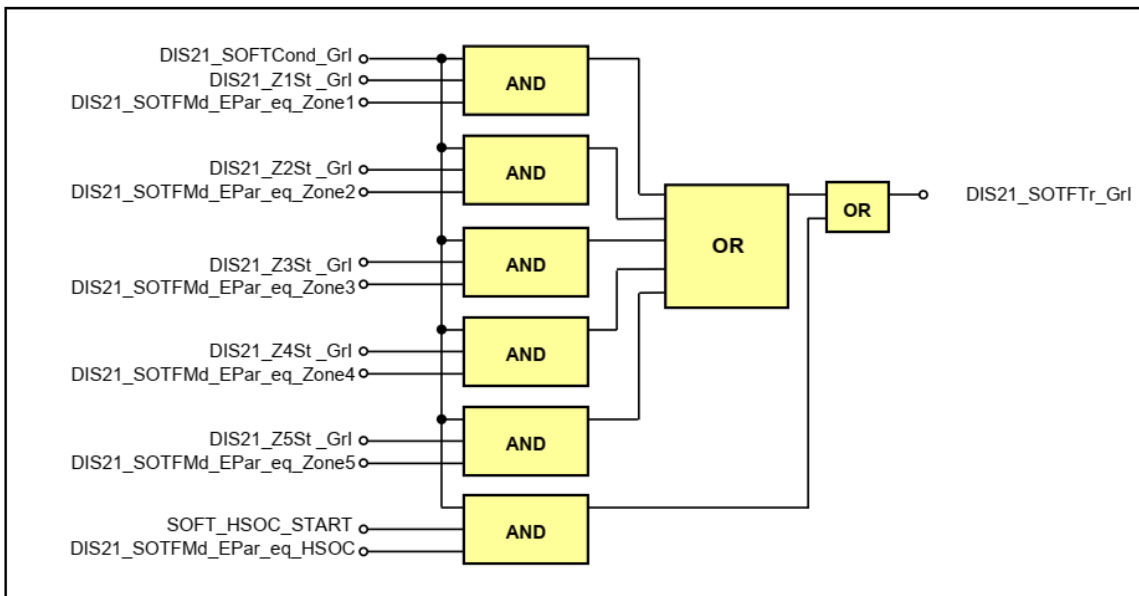

Figure 1-21 The internal logic of the SOTF function

In this diagram, the additional binary input signals:

Binary input signals	Signal title	Explanation
DIS21_Z1St_Grl		Started state of the distance protection Zone1
DIS21_Z2St_Grl		Started state of the distance protection Zone2
DIS21_Z3St_Grl		Started state of the distance protection Zone3
DIS21_Z4St_Grl		Started state of the distance protection Zone4
DIS21_Z5St_Grl		Started state of the distance protection Zone5
SOTF_HSOC_START		Started state of the HSOC function

Table 1-41 The integer parameters of the SOTF logic

c

4.1.2.9. The on-line measured values of the distance protection function

Name	Title	Explanation
DIS21_HTXkm_OLM_	Fault location	Measured distance to fault in kilometers
DIS21_HTXohm_OLM_	Fault react.	Measured reactance to fault
DIS21_L1N_R_OLM_	L1N loop R	Measured positive sequence resistance in L1N loop
DIS21_L1N_X_OLM_	L1N loop X	Measured positive sequence reactance in L1N loop
DIS21_L2N_R_OLM_	L2N loop R	Measured positive sequence resistance in L2N loop
DIS21_L2N_X_OLM_	L2N loop X	Measured positive sequence reactance in L2N loop
DIS21_L3N_R_OLM_	L3N loop R	Measured positive sequence resistance in L3N loop
DIS21_L3N_X_OLM_	L3N loop X	Measured positive sequence reactance in L3N loop
DIS21_L12_R_OLM_	L12 loop R	Measured positive sequence resistance in L12 loop
DIS21_L12_X_OLM_	L12 loop X	Measured positive sequence reactance in L12 loop
DIS21_L23_R_OLM_	L23 loop R	Measured positive sequence resistance in L23 loop
DIS21_L23_X_OLM_	L23 loop X	Measured positive sequence reactance in L23 loop
DIS21_L31_R_OLM_	L31 loop R	Measured positive sequence resistance in L31 loop
DIS21_L31_X_OLM_	L31 loop X	Measured positive sequence reactance in L31 loop

Table 1-42 The measured values of the distance protection function

4.1.2.10. Technical summary

4.1.2.10.1. Technical data

Function	Range	Accuracy
Number of zones	5	
Rated current I_n	1/5A, parameter setting	
Rated voltage U_n	100/200V, parameter setting	
Current effective range	20 – 2000% of I_n	$\pm 1\%$ of I_n
Voltage effective range	2-110 % of U_n	$\pm 1\%$ of U_n
Impedance effective range $I_n=1A$ $I_n=5A$	0.1 – 200 Ohm 0.1 – 40 Ohm	$\pm 5\%$
Zone static accuracy	48 Hz – 52 Hz 49.5 Hz – 50.5 Hz	$\pm 5\%$ $\pm 2\%$
Zone angular accuracy		$\pm 3^\circ$
Operate time	Typically 25 ms	± 3 ms
Minimum operate time	<20 ms	
Reset time	16 – 25 ms	
Reset ratio	1.1	

Table 1-43 Technical data of the 5-zone distance protection

4.1.2.10.2. The measured values

The **measured values** of the distance protection function.

Measured value	Dim.	Explanation
$ZL1 = RL1+j XL1$	ohm	Measured positive sequence impedance in the L1N loop, using the zero sequence current compensation factor for zone 1
$ZL2 = RL2+j XL2$	ohm	Measured positive sequence impedance in the L2N loop, using the zero sequence current compensation factor for zone 1
$ZL3 = RL3+j XL3$	ohm	Measured positive sequence impedance in the L3N loop, using the zero sequence current compensation factor for zone 1
$ZL1L2 = RL1L2+j XL1L2$	ohm	Measured positive sequence impedance in the L1L2 loop
$ZL2L3 = RL2L3+j XL2L3$	ohm	Measured positive sequence impedance in the L2L3 loop
$ZL3L1 = RL3L1+j XL3L1$	ohm	Measured positive sequence impedance in the L3L1 loop
Fault location	km	Measured distance to fault
Fault react.	ohm	Measured reactance in the fault loop

Table 1-44 The measured analogue values of the distance protection function

4.1.2.10.3. Summary of the parameters

The parameters of the distance protection function are explained in the following tables.

Enumerated parameters

Parameter name	Title	Selection range	Default
Parameters to select directionality of the individual zones:			
DIS21_Z1_EPar_	Operation Zone1	Off, Forward, Backward	Off
DIS21_Z2_EPar_	Operation Zone2	Off, Forward, Backward, Offset	Off
DIS21_Z3_EPar_	Operation Zone3	Off, Forward, Backward, Offset	Off
DIS21_Z4_EPar_	Operation Zone4	Off, Forward, Backward, Offset	Off
DIS21_Z5_EPar_	Operation Zone5	Off, Forward, Backward, Offset	Off
Parameters for power swing detection:			
DIS21_PSD_EPar_	Operation PSD	Off, 1 out of 3, 2 out of 3, 3 out of 3	1 out of 3
Parameter enabling "out-of-step" function:			
DIS21_Out_EPar_	Oper OutOfStep	Off, On	Off
Parameter for selecting one of the zones or "high speed overcurrent protection" for the "switch-onto-fault" function:			
DIS21_SOTFMd_EPar _	SOTF Zone	Off, Zone1, Zone2, Zone3, Zone4, Zone5, HSOC	Zone1

Table 1-45 The enumerated parameters of the distance protection function

Boolean parameters for the individual zones to generate trip command (0) or to indicate starting only (1):

Parameter name	Title	Default	Explanation
DIS21_Z1St_BPar_	Zone1 Start Only	0	0 for Zone1 to generate trip command
DIS21_Z2St_BPar_	Zone2 Start Only	0	0 for Zone2 to generate trip command
DIS21_Z3St_BPar_	Zone3 Start Only	0	0 for Zone3 to generate trip command
DIS21_Z4St_BPar_	Zone4 Start Only	0	0 for Zone4 to generate trip command
DIS21_Z5St_BPar_	Zone5 Start Only	0	0 for Zone5 to generate trip command

Table 1-46 The Boolean parameters of the distance protection function

Boolean parameters for the individual zones to be blocked by the Power Swing Detection (PSD) function (1):

Parameter name	Title	Default	Explanation
DIS21_Z1St_BPar_	PSD Block Z1	0	1 for Zone1 to be blocked by PSD
DIS21_Z2St_BPar_	PSD Block Z2	0	1 for Zone2 to be blocked by PSD
DIS21_Z3St_BPar_	PSD Block Z3	0	1 for Zone3 to be blocked by PSD
DIS21_Z4St_BPar_	PSD Block Z4	0	1 for Zone4 to be blocked by PSD
DIS21_Z5St_BPar_	PSD Block Z5	0	1 for Zone5 to be blocked by PSD

Table 1-47 The Boolean parameters of the distance protection function



C

Integer parameters

Parameter name	Title	Unit	Min	Max	Step	Default
Definition of minimal current enabling impedance calculation:						
DIS21_Imin_IPar_	I _{Ph} Base Sens	%	10	30	1	20
Definition of zero sequence current characteristic enabling impedance calculation in phase-to-earth loops:						
DIS21_IoBase_IPar_	I _{Res} Base Sens	%	10	50	1	10
DIS21_IoBias_IPar_	I _{Res} Bias	%	5	30	1	10
Definition of the load angle of the polygon characteristic:						
DIS21_LdAng_IPar_	Load Angle	deg	0	45	1	30
Definition of the line angle:						
DIS21_LinAng_IPar_	Line Angle	deg	0	90	1	75
Definition of the ratio of the characteristics for power swing detection:						
DIS21_RRat_IPar_	PSD R _{out} /R _{in}	%	120	160	1	130
DIS21_XRat_IPar_	PSD X _{out} /X _{in}	%	120	160	1	130
Definition of the overcurrent setting for the switch-onto-fault function, for the case where the DIS21_SOTFMd_EPar_ (SOTF Zone) parameter is set to "HSOC":						
DIS21_SOTFOC_IPar_	SOTF Current	%	10	1000	1	200

Table 1-48 The integer parameters of the distance protection function

C

4.1.2.11. The function block

The function block of the distance protection function is shown in Figure 1-22. This block shows all binary input and output status signals that are applicable in the graphic logic editor.

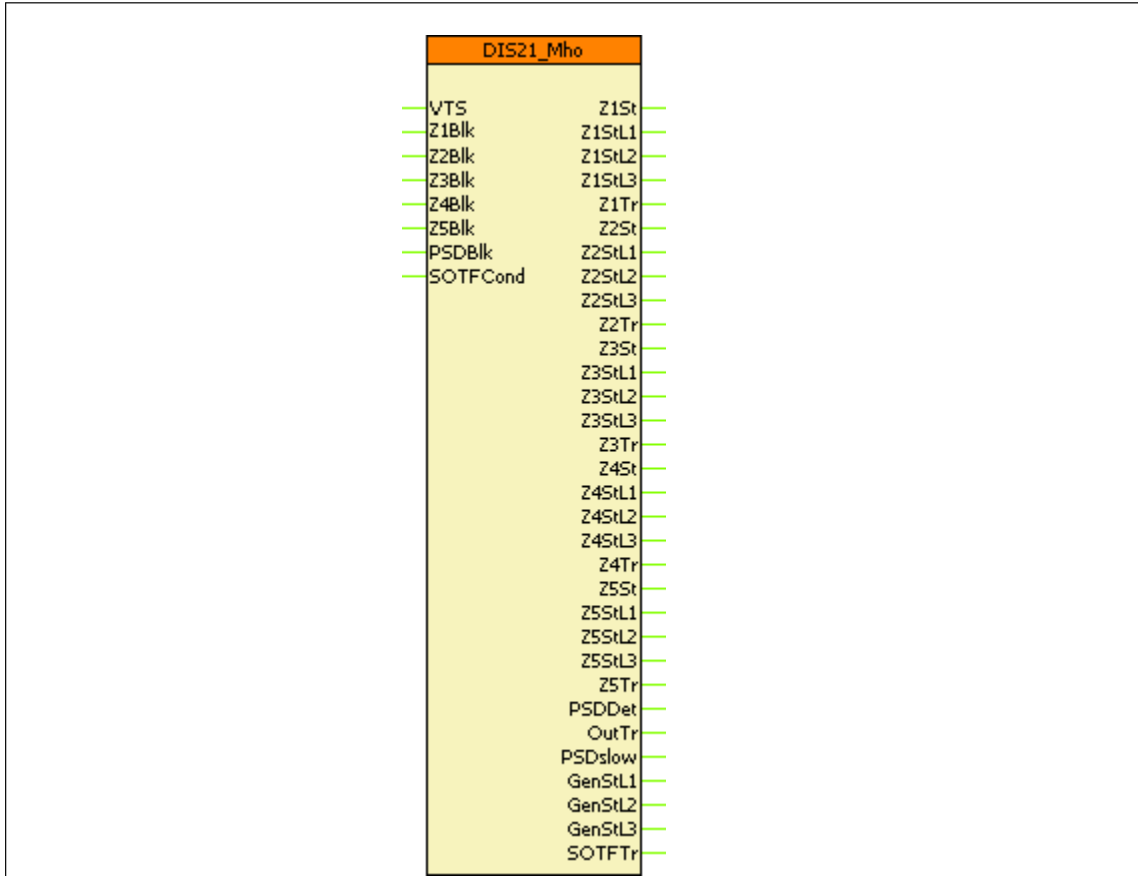

Figure 1-22 The function block of the distance protection function with MHO characteristic

C

4.1.3. Switch-onto-fault preparation function

Some protection functions, e.g. distance protection, directional overcurrent protection, etc. need to decide the direction of the fault. This decision is based on the angle between the voltage and the current. In case of close-up faults, however, the voltage of the faulty loop is near zero: it is not sufficient for a directional decision. If there are no healthy phases, then the voltage samples stored in the memory are applied to decide if the fault is forward or reverse.

If the protected object is energized, the close command for the circuit breaker is received in “dead” condition. This means that the voltage samples stored in the memory have zero values. In this case the decision on the trip command is based on the programming of the protection function for the “switch-onto-fault” condition.

This “switch-onto-fault” detection function prepares the conditions for the subsequent decision.

The function can handle both automatic and manual close commands.

The automatic close command is not an input for this function. It receives the “Dead line” status signal from the DLD (dead line detection) function block. After dead line detection, the AutoSOTF binary output signal is delayed by a timer with a constant 200 ms time delay. After voltage detection (resetting of the dead line detection input signal), the drop-off of this output signal is delayed by a timer set by the user.

The manual close command is an input binary signal. The drop-off of the output signal ManSOTF is delayed by a timer with timing set by the user.

The fault detection is the task of the subsequent distance protection, directional overcurrent protection, etc.

The operation of the “switch-onto-fault” detection function is shown in Figure 1-1.

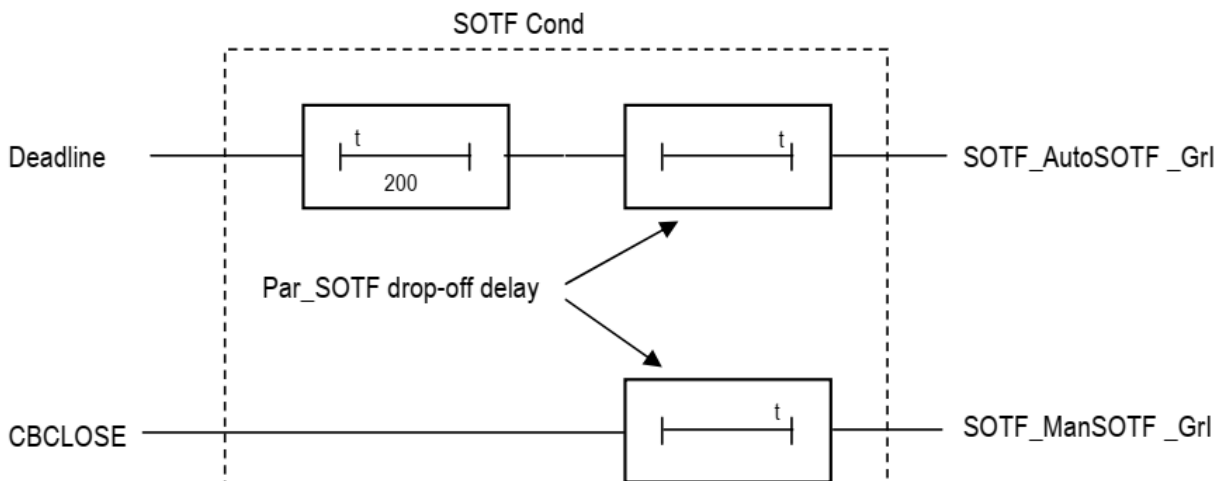

Figure 1-1 The scheme of the “switch-onto-fault” preparation

4.1.3.1. Operation of the switch-onto-fault detection algorithm

The binary input signals of the “switch-onto-fault” detection function are:

- CBClose Manual close command to the circuit breaker,
- DeadLine Dead line condition detected; this is usually the output signal of the DLD (dead line detection) function block.

After dead line detection, the AutoSOTF binary output signal is delayed by a timer with a constant 200 ms time delay. After voltage detection (resetting of the dead line detection input signal), the drop-off of this output signal is delayed by a timer set by the user.

The manual close command is an input binary signal. The drop-off of the output signal ManSOTF is delayed by a timer with timing set by the user. The timer parameter is common for both the automatic and manual close command.

The binary output signals of the “switch-onto-fault” detection function are separate for automatic and manual close commands:

- AutoSOTF cond Signal enabling switch-onto-fault detection as a consequence of an automatic close command,
- ManSOTF cond Signal enabling switch-onto-fault detection as a consequence of a manual close command.

4.1.3.2. Technical summary

4.1.3.2.1. Technical data

Function	Accuracy
Timer accuracy	±5% or ±15 ms, whichever is greater

Table 1-1 Technical data of the switch-onto-fault detection function

4.1.3.2.2. The parameter

The parameter of the switch-onto-fault detection function is explained in the following table.

Timer parameter

Parameter name	Title	Unit	Min	Max	Step	Default
Drop-off time delay for the output signals						
SOTF_SOTFDeI_TPar_	SOTF Drop Delay	msec	100	10000	1	1000

Table 1-2 The timer parameter of the switch-onto-fault detection function

4.1.3.2.3. Binary output status signals

The **binary output status signals** of the switch-onto-fault detection function.

Binary output signals	Signal title	Explanation
Signal enabling switch-onto-fault detection as a consequence of automatic close command		
SOTF_AutoSOTF_GrI_	AutoSOTF cond	Signal enabling switch-onto-fault detection as a consequence of automatic close command
Signal enabling switch-onto-fault detection as a consequence of manual close command		
SOTF_ManSOTF_GrI_	ManSOTF cond	Signal enabling switch-onto-fault detection as a consequence of manual close command

Table 1-3 The binary output status signals of the switch-onto-fault detection function

4.1.3.2.4. Binary input status signals

The **binary inputs** are signals influencing the operation of the switch-onto-fault detection function. **These signals are the results of logic equations graphically edited by the user.**

Binary input signal	Signal title	Explanation
Manual close command to the circuit breaker		
SOTF_CBClose_GrO_	CBClose	Manual close command to the circuit breaker
Dead line condition detected		
SOTF_DeadLine_GrO_	DeadLine	Dead line condition detected

Table 1-4 The binary input signals of the switch-onto-fault detection function

4.1.3.2.5. The function block

The function block of the switch-onto-fault detection function is shown in Figure 1-2. This block shows all binary input and output status signals that are applicable in the graphic equation editor.

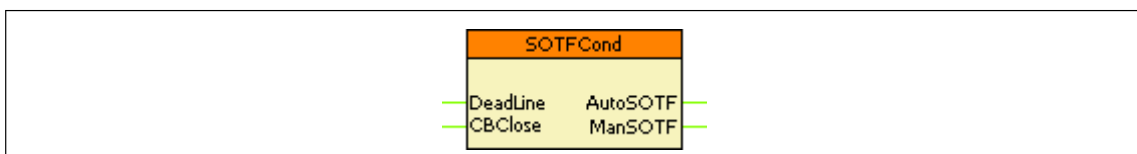
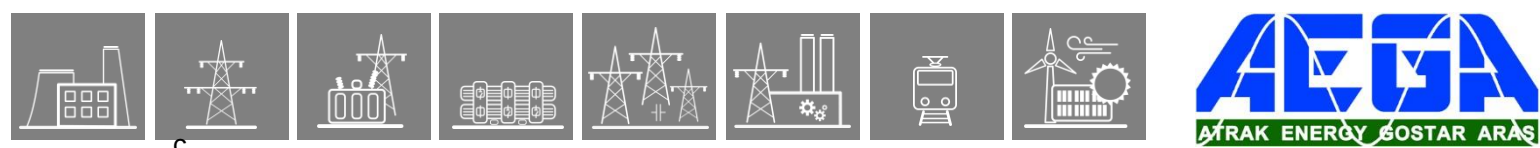

Figure 1-2 The function block of the switch-onto-fault detection function



C

4.1.4. Synchro check / synchro switch function

4.1.4.1. Application

Several problems can occur in the electric power system if the circuit breaker closes and connects two systems operating asynchronously. The high current surge can cause damage in the interconnecting elements, the accelerating forces can overstress the shafts of rotating machines or the actions taken by the protective system can result in the unwanted separation of parts of the electric power system.

To prevent such problems, this function checks whether the systems to be interconnected are operating synchronously. If yes, then the close command is transmitted to the circuit breaker. In case of asynchronous operation, the close command is delayed to wait for the appropriate vector position of the voltage vectors on both sides of the circuit breaker. If the conditions for safe closing cannot be fulfilled within an expected time, then closing is declined.

The conditions for safe closing are as follows:

- The difference of the voltage magnitudes is below the declared limit,
- The difference of the frequencies is below the declared limit and
- The angle difference between the voltages on both sides of the circuit breaker is within the declared limit.

4.1.4.2. Mode of operation

The function processes both automatic reclosing and manual close commands.

The limits for automatic reclosing and manual close commands can be set independently of each other.

The function compares the voltage of the line and the voltage of one of the bar sections (Bus1 or Bus2). The bus selection is made automatically based on a binary input signal defined by the user applying the graphic equation editor.

As to voltages: any phase-to-ground or phase-to-phase voltage can be selected.

The function processes the signals of the voltage transformer supervision function and enables the close command only in case of plausible voltages.

There are three modes of operation:

- Energizing check:
 - Dead bus, live line,
 - Live bus, dead line,
 - Any Energizing Case (including Dead bus, dead line).
- Synchro check (Live line, live bus)
- Synchro switch (Live line, live bus)

If the conditions for “Energizing check” or “Synchro check” are fulfilled, then the function generates the release command, and in case of a manual or automatic close request, the close command is generated.

If the conditions for energizing and synchronous operation are not met when the close request is received, then synchronous switching is attempted within the set time-out. In this case, the rotating vectors must fulfill the conditions for safe switching within the declared waiting time: at the moment the contacts of the circuit breaker are closed, the voltage vectors must match each other with appropriate accuracy. For this mode of operation, the expected operating time of the circuit breaker must be set as a parameter value, to generate the close command in advance taking the relative vector rotation into consideration.

The started checking procedure can be interrupted by a cancel command defined by the user in the graphic equation editor.

In “bypass” operation mode, the function generates the release signals and simply transmits the close command.

4.1.4.3. Structure of the synchro check/synchro switch function

The synchro check/synchro switch function contains two kinds of software blocks (See Figure 1-1):

- SYN25_Com is a common block for manual switching and automatic switching
- SYN25_EVA is an evaluation block, duplicated for manual switching and for automatic switching

These software blocks are explained in detail below.

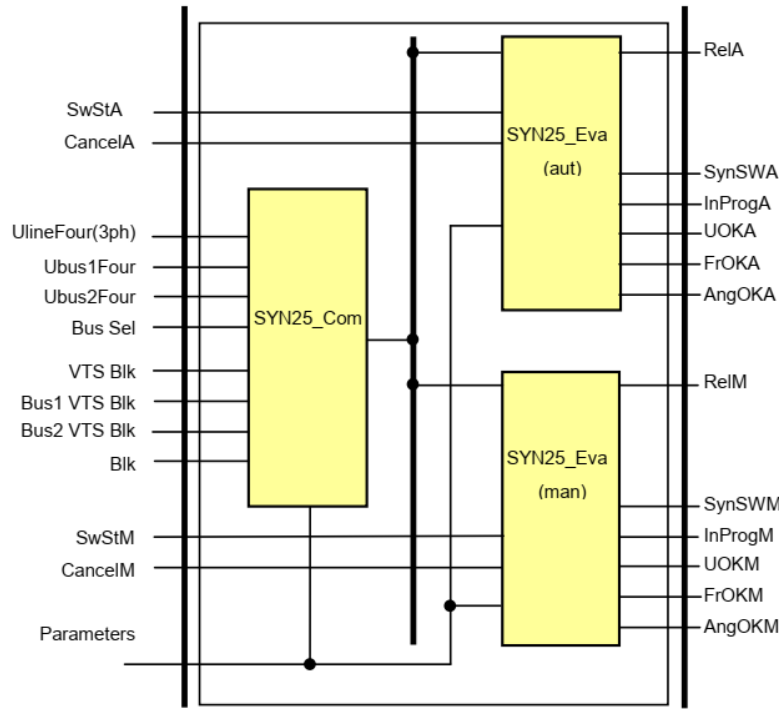
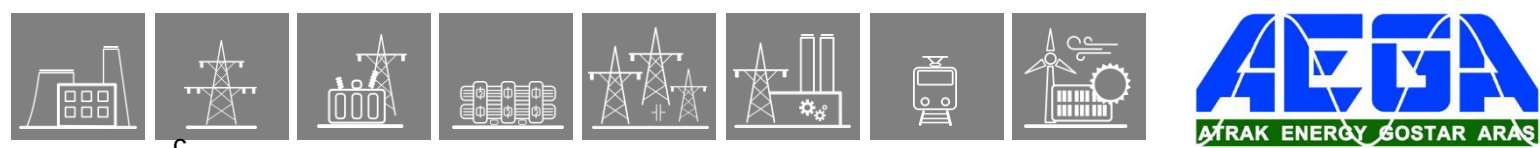

Figure 1-1 Structure of the synchro check/synchro switch function

Analog input signals

The function processes the result of three Fourier calculation blocks. These modules process the following voltages of the line and those of two bus sections.

- **UlineFour(3ph)** the Fourier components of the three phase voltages. The module selects one phase or one line-to-line voltage based on this set to be matched to the bus voltages.
- **Ubus1Four** and **Ubus2Four** the Fourier components characteristic for the bus sections. These can be a phase voltages of the same phase as it is selected from UlineFour(3ph) or matching line-to-line voltages. The selection is made by the parameter value of SYN25_VoltSel_EPar_ (Voltage select) (see Table 1-4). Between the two bus sections, a binary input signal controls the selection SYN25_BusSel_GrO_ (Bus select).



C

Binary input status signals

The synchro check / synchro switch function has binary input signals. **The conditions are defined by the user, applying the graphic equation editor.**

The **binary input status signals** of the synchro check / synchro switch function are listed in Table 1-1.

Binary status signal	Title	Explanation
SYN25_BlK_GrO_	Block	Blocking signal of the function
SYN25_BusSel_GrO_	Bus select	If this signal is logic TRUE, then the voltage of Bus2 is selected for evaluation
SYN25_VTSBlk_GrO_	VTS Block	Blocking signal of the voltage transformer supervision function evaluating the line voltage
SYN25_Bus1VTSBlk_GrO_	VTS Bus1 Block	Blocking signal of the voltage transformer supervision function evaluating the Bus1 voltage
SYN25_Bus2VTSBlk_GrO_	VTS Bus2 Block	Blocking signal of the voltage transformer supervision function evaluating the Bus2 voltage
SYN25_SwStA_GrO_	SySwitch Auto	Switching request signal initiated by the automatic reclosing function
SYN25_CancelA_GrO_	Cancel Auto	Signal to interrupt (cancel) the automatic switching procedure
SYN25_SwStM_GrO_	SySwitch Manual	Switching request signal initiated by manual closing
SYN25_CancelM_GrO_	Cancel Manual	Signal to interrupt (cancel) the manual switching procedure

Table 1-1 The binary input status signals of the synchro check / synchro switch function

The function is disabled if

- The binary input SYN25_BlK_GrO_ (Block) signal is TRUE
- The voltage transformer supervision circuit for the line voltage blocks the operation SYN25_VTSBlk_GrO_ (VTS Block)
- The voltage transformer supervision circuit for the selected bus section blocks the operation SYN25_Bus1VTSBlk_GrO_ (VTS Bus1 Block) or SYN25_Bus2VTSBlk_GrO_ (VTS Bus2 Block)
- Parameter settings disable the operation (see details below)

The function can be started by the following binary input signals:

- SYN25_SwStA_GrO_ (SySwitch Auto) automatic starting
- starting SYN25_SwStM_GrO_ (SySwitch Manual) manual starting

If the function is in operation, then the process can be stopped (canceled) by the following binary input signals:

- SYN25_CancelA_GrO_ (Cancel Auto) canceling the automatic operation
- operation SYN25_CancelM_GrO_ (Cancel Manual) canceling the manual operation.

C

The **binary output status signals** of the synchro check / synchro switch function are listed in Table 1-2.

Binary status signal	Title	Explanation
SYN25_RelA_Grl_	Release Auto	Releasing the close command initiated by the automatic reclosing function
SYN25_InProgA_Grl_	SynInProgr Auto	Switching procedure is in progress, initiated by the automatic reclosing function
SYN25_SynSWA_Grl_ *	Syn Cmd Auto *	Switching command initiated by the automatic reclosing function *
SYN25_UOKA_Grl_	Udiff OK Auto	The voltage difference is appropriate for automatic closing command
SYN25_FrOKA_Grl_	FreqDiff OK Auto	The frequency difference is appropriate for automatic closing command, evaluated for synchro-check **
SYN25_AngOKA_Grl_	Angle OK Auto	The angle difference is appropriate for automatic closing command
SYN25_RelM_Grl_	Release Man	Releasing the close command, initiated by manual closing request
SYN25_InProgM_Grl_	SynInProgr Man	Switching procedure is in progress, initiated by the manual closing command
SYN25_SynSWM_Grl_ *	Syn Cmd Man *	Switching command initiated by the manual closing command *
SYN25_UOKM_Grl_	Udiff OK Man	The voltage difference is appropriate for manual closing command
SYN25_FrOKM_Grl_	FreqDiff OK Man	The frequency difference is appropriate for manual closing command, evaluated for synchro-check **
SYN25_AngOKM_Grl_	Angle OK Man	The angle difference is appropriate for manual closing command
SYN25_SynSW_Grl_ *	Syn Cmd *	Switching command, OR connection of manual and automatic closing*

* This command can be assigned directly to an output contact (defined in the "L1 contact" menu of the EuroCap configuration software), it is not published for logic signal processing, using the graphic editor

** The frequency is evaluated using the weighted sum of the three phase voltages

Table 1-2 The binary output status signals of the synchro check / synchro switch function

4.1.4.3.1. The common software block

In this paragraph the operation of the software block SYN25_Com of the Figure 1-1 is described. This block selects the appropriate voltages for processing and calculates the voltage difference, the frequency difference and the phase angle difference between the selected voltages. The magnitude of the selected voltages is passed for further evaluation, too. The structure of this software block is shown on Figure 1-2.

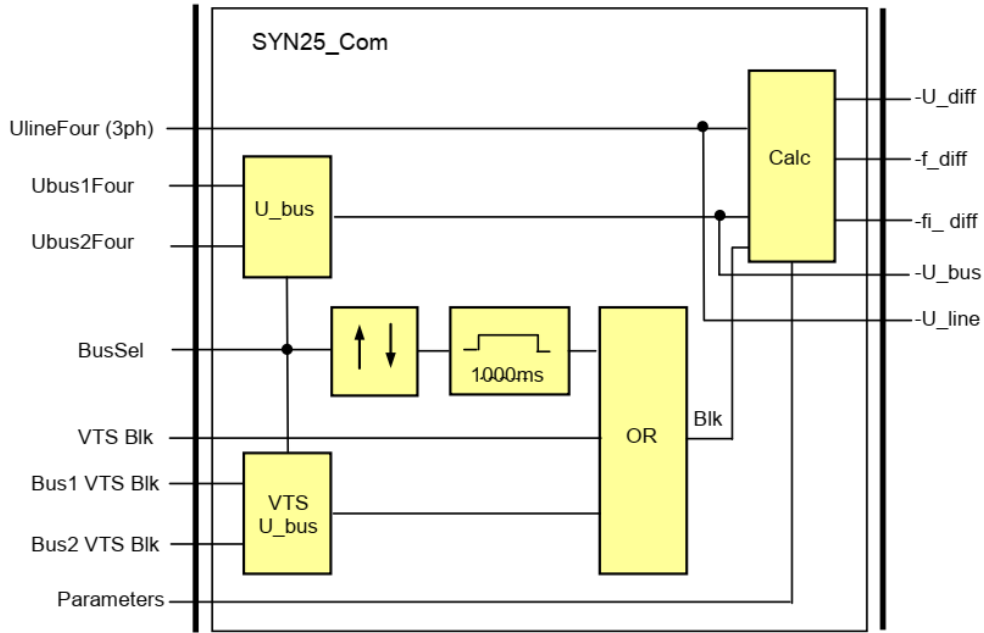

Figure 1-2 Structure of the common software block

Analog input signals

The function processes the result of three Fourier calculation blocks. These modules process the following voltages of the line and those of two bus sections.

- **UlineFour(3ph)** the Fourier components of the three phase voltages. The module selects one phase or one line-to-line voltage based on this set to be matched to the bus voltages.
- **Ubus1Four** and **Ubus2Four** the Fourier components characteristic for the bus sections. These can be a phase voltages of the same phase as it is selected from UlineFour(3ph) or matching line-to-line voltages. The selection is made by the parameter value of SYN25_VoltSel_EPar_ (Voltage select) (see Table 1-4). Between the two bus sections, a binary input signal controls the selection SYN25_BusSel_GrO_ (Bus select).

Binary input status signals

The synchro check / synchro switch function has binary input signals. **The conditions are defined by the user, applying the graphic equation editor.**

The **binary input status signals** of the synchro check / synchro switch function are listed in Table 1-3.

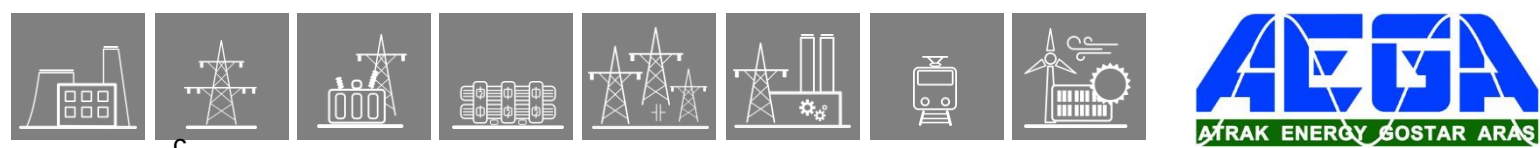

C

Binary status signal	Title	Explanation
SYN25_BusSel_GrO_	Bus select	If this signal is logic TRUE, then the voltage of Bus2 is selected for evaluation
SYN25_VTSBlk_GrO_	VTS Block	Blocking signal of the voltage transformer supervision function evaluating the line voltage
SYN25_Bus1VTSBlk_GrO_	VTS Bus1 Block	Blocking signal of the voltage transformer supervision function evaluating the Bus1 voltage
SYN25_Bus2VTSBlk_GrO_	VTS Bus2 Block	Blocking signal of the voltage transformer supervision function evaluating the Bus2 voltage
SYN25_Blk_GrO_	Block	Blocking signal of the function

Table 1-3 The binary input status signals of the common software block

The calculated or selected output values are:

- U_diff the magnitude difference between the selected voltages
- f_diff the frequency difference between the selected voltages
- fi_diff the phase angle difference between the selected voltages
- U_line the magnitude of the selected line voltage
- U_bus the magnitude of the voltage of the appropriate bus section

These values are further processed by the evaluation software blocks (See Figure 1-1).

The function is disabled if

- The binary input SYN25_Blk_GrO_ (Block) signal is TRUE
- The voltage transformer supervision circuit for the line voltage blocks the operation SYN25_VTSBlk_GrO_ (VTS Block)
- The voltage transformer supervision circuit for the selected bus section blocks the operation SYN25_Bus1VTSBlk_GrO_ (VTS Bus1 Block) or SYN25_Bus2VTSBlk_GrO_ (VTS Bus2 Block)
- Parameter settings disable the operation (see details below)

If the active bus section changes, then the function is dynamically blocked for 1000 ms; no release signal or switching command is generated.

This software block has no **binary output status signals**.

The processed line voltage is selected based on the preset parameter SYN25_VoltSel_EPar_ (Voltage select). The choice is: L1-N,L2-N,L3-N,L1-L2,L2-L3,L3-L1. The parameter value must match the input voltages received from the bus sections.

The active bus section is selected by the input signal SYN25_BusSel_GrO_ (Bus select). If this signal is logic TRUE, then the voltage of Bus2 is selected for evaluation.

The parameter of this software block is shown in Table 1-4 below:

Enumerated parameter

Parameter name	Title	Selection range	Default
Selection of the processed voltage			
SYN25_VoltSel_EPar_	Voltage Select	L1-N,L2-N,L3-N,L1-L2,L2-L3,L3-L1	L1-N

Table 1-4 The enumerated parameter of the common software block

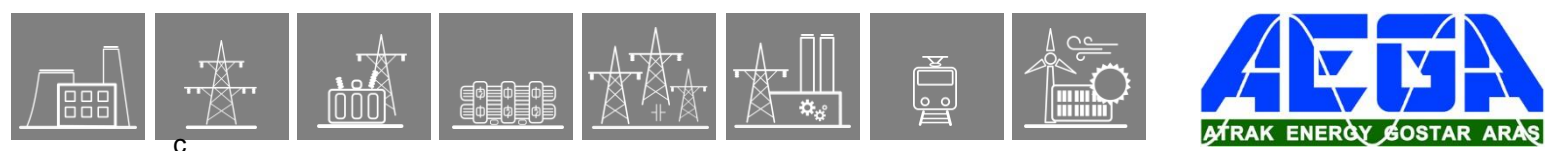

C

4.1.4.3.2. The evaluation software block

The operation of the software block SYN25_Eva of Figure 1-1 is described in this paragraph. This software block is applied separately for automatic and manual commands. This separation allows the application to use different parameter values for the two modes of operation.

The structure of the evaluation software block is shown in Figure 1-3.

Analog input signals

The function processes the results of the common block (See Paragraph 1.3.1).

The analog input values are:

- U_diff the magnitude difference between the selected voltages
- f_diff the frequency difference between the selected voltages
- fi_diff the phase angle difference between the selected voltages
- U_line the magnitude of the selected line voltage
- U_bus the magnitude of the voltage of the appropriate bus section

Binary input status signals

The evaluation software block has binary input status signals. **The conditions are defined by the user, applying the graphic equation editor.**

The **binary input status signals** of the evaluation software block are listed in Table 1-5

Binary status signal	Title	Explanation
SYN25_SwStA_GrO_	SySwitch Auto	Switching request signal initiated by the automatic reclosing function
SYN25_CancelA_GrO_	Cancel Auto	Signal to interrupt (cancel) the automatic switching procedure
SYN25_SwStM_GrO_	SySwitch Manual	Switching request signal initiated by manual closing
SYN25_CancelM_GrO_	Cancel Manual	Signal to interrupt (cancel) the manual switching procedure

Table 1-5 The binary input signal of the evaluation software block

The **binary output status signals** of the evaluation software block are shown in Table 1-6 for automatic starting and in Table 1-7 for manual starting.

C

Binary status signal	Title	Explanation
SYN25_RelA_Grl_	Release Auto	Releasing the close command initiated by the automatic reclosing function
SYN25_InProgA_Grl_	SynInProgr Auto	Switching procedure is in progress, initiated by the automatic reclosing function
SYN25_UOKA_Grl_	Udiff OK Auto	The voltage difference is appropriate for automatic closing command
SYN25_FrOKA_Grl_	FreqDiff OK Auto	The frequency difference is appropriate for automatic closing command, evaluated for synchro-check **
SYN25_AngOKA_Grl_	Angle OK Auto	The angle difference is appropriate for automatic closing command
SYN25_SynSWA_Grl_ *	Syn Cmd Auto *	Switching command initiated by the automatic reclosing function *

▪ This command can be assigned directly to an output contact; it is not published for logic signal processing, using the graphic editor

** The frequency is evaluated using the weighted sum of the three phase voltages

Table 1-6 The binary output status signals of the evaluation software block for automatic starting

Binary status signal	Title	Explanation
SYN25_RelM_Grl_	Release Man	Releasing the close command, initiated by manual closing request
SYN25_InProgM_Grl_	SynInProgr Man	Switching procedure is in progress, initiated by the manual closing command
SYN25_UOKM_Grl_	Udiff OK Man	The voltage difference is appropriate for manual closing command
SYN25_FrOKM_Grl_	FreqDiff OK Man	The frequency difference is appropriate for manual closing command, evaluated for synchro-check **
SYN25_AngOKM_Grl_	Angle OK Man	The angle difference is appropriate for manual closing command
SYN25_SynSWM_Grl_ *	Syn Cmd Man *	Switching command initiated by the manual closing command *

▪ This command can be assigned directly to an output contact; it is not published for logic signal processing, using the graphic editor

** The frequency is evaluated using the weighted sum of the three phase voltages

Table 1-7 The binary output status signals of the evaluation software block for manual starting

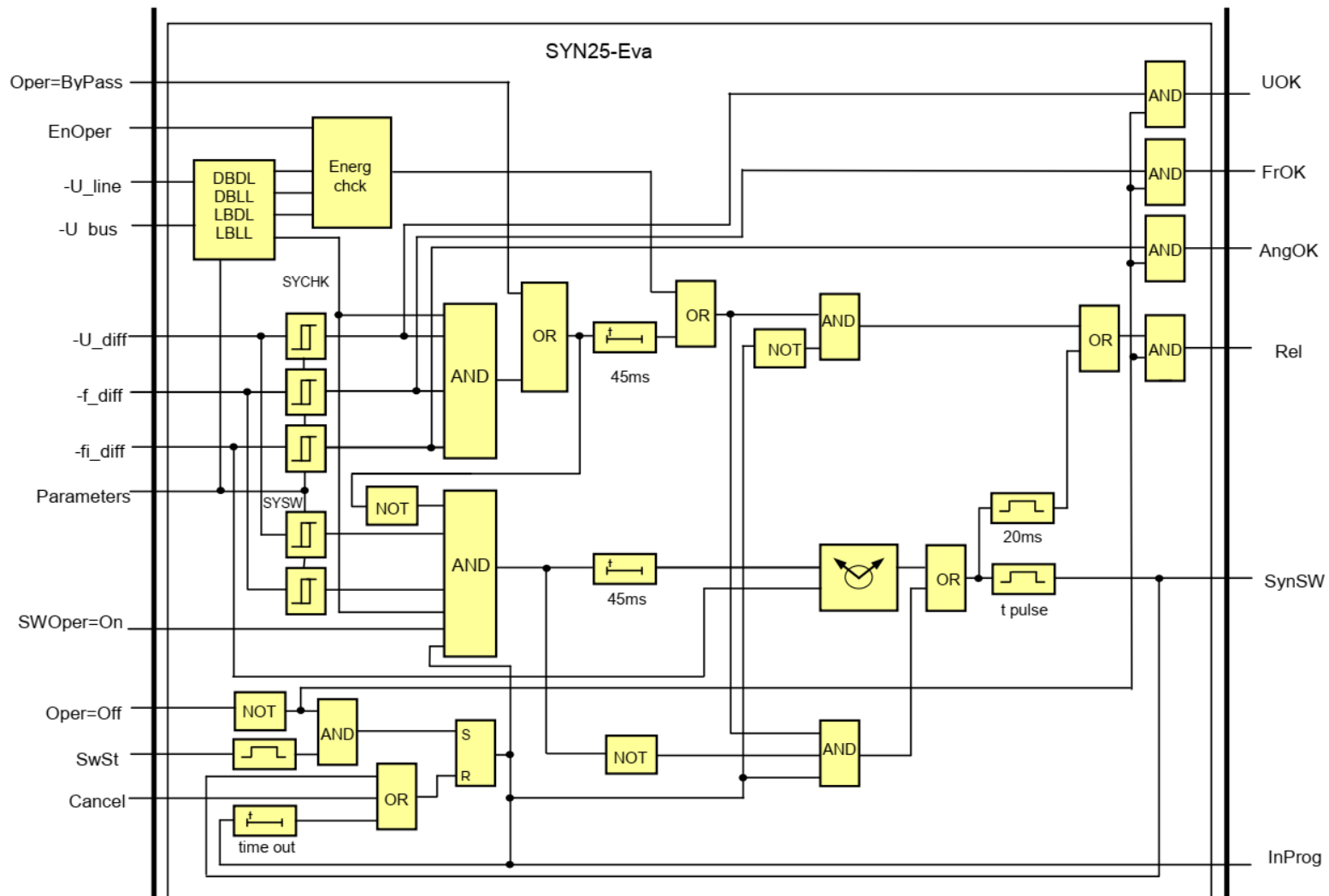
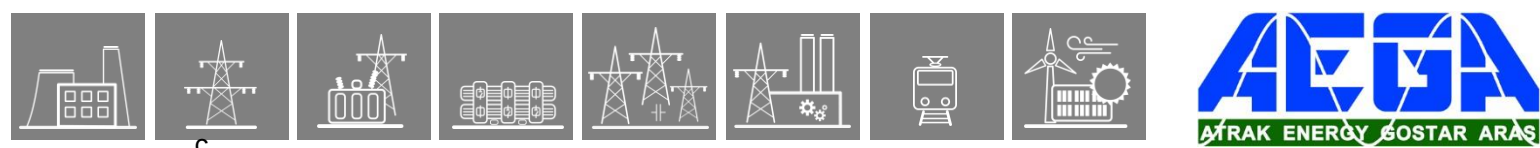

Figure 1-3 Structure of the evaluation software block



C

Explanation of the operation

This evaluation software block is used for two purposes: for the automatic reclosing command (the signal names have the suffix "A") and for the manual close request (the signal names have the suffix "M").

As the first step, based on the selected line voltage and bus voltage, the state of the required switching is decided (Dead bus-Dead line, Dead bus-Live line, Live bus-Dead line or Live bus-Live line). The parameters for decision are SYN25_LiveU_IPar_ (U Live) and SYN25_DealU_IPar_ (U Dead). The enumerated parameters SYN25_EnOperA_EPar_ / SYN25_EnOperM_EPar_ (Energizing Auto/Manual) enable the operation individually. The choice is: (Off, DeadBus LiveLine, LiveBus DeadLine, Any energ case). In simple energizing modes, no further checking is needed.

This mode selection is bypassed if the parameter SYN25_OperA_EPar_ SYN25_OperM_EPar_ (Operation Auto/Manual) is set to "ByPass". In this case the command is transmitted without any further checking.

First, the function tries switching with synchro check (SYCHK on the Figure 1-3). This is possible if:

- the voltage difference is within the defined limits (parameters SYN25_ChkUdA_IPar_ / SYN25_ChkUdM_IPar_ (Udiff SynChk Auto/Manual))
- the frequency difference is within the defined limits (parameters SYN25_ChkFrDA_FPar_ / SYN25_ChkFrDM_FPar_ (FrDiff SynChk Auto)) and
- the phase angle difference is within the defined limits (parameters SYN25_MaxPhDiffA_IPar_, / SYN25_MaxPhDiffA_IPar_ (MaxPhaseDiff Auto/Manual)).

These conditions are signaled on dedicated binary outputs:

- SYN25_UOKM_GrI_ / SYN25_UOKA_GrI_ if the voltage magnitudes are OK
- SYN25_FrOKM_GrI_ / SYN25_FrOKA_GrI_ if the frequency difference is OK
- SYN25_AngOKM_GrI_ / SYN25_AngOKA_GrI_ if the angle difference is OK

If the conditions are fulfilled for at least 45 ms, then the function generates a release output signal SYN25_ReIM_GrI_ / SYN25_ReIA_GrI_ (Release Auto/Manual).

If the conditions for synchro check operation are not fulfilled and a close request is received as the input signal SYN25_SwStA_GrO_ / SYN25_SwStM_GrO_ (SySwitch Auto/Manual), then synchro switching is attempted. (SYSW in Figure 1-3). This is possible if:

- the voltage difference is within the defined limits (parameters SYN25_SwUdA_IPar_ / SYN25_SwUdM_IPar_ (Udiff SynSW Auto /Manual))
- the frequency difference is within the defined limits (parameters SYN25_SwFrDA_FPar_ / SYN25_SwFrDM_FPar_ (FrDiff SynSW Auto)).

These parameters are independent of those for the synchro check function.

If the conditions for synchro check are not fulfilled and the conditions for synchro switch are OK, then the relative rotation of the voltage vectors is monitored. The command is generated before the synchronous position, taking the breaker closing time into consideration SYN25_CBTrav_TPar_ (Breaker Time). The pulse duration is defined by the parameter SYN25_SwPu_TPar_ (Close Pulse).

In case of slow rotation and if the vectors are for a long time near-opposite vector positions, the waiting time is limited by the preset parameter SYN25_MaxSw_TPar_ (Max.Switch Time).

The progress is indicated by the output status signal SYN25_InProgM_GrI_ / SYN25_InProgM_GrI_ (SynInProgr Auto/Manual).

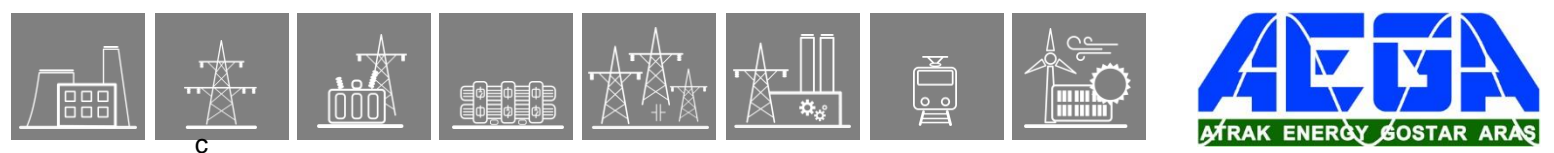

The started command can be canceled using the input signal SYN25_CancelA_GrO_/ SYN25_CancelM_GrO_ (Cancel Auto/Manual).

Enumerated parameters for automatic switching

Parameter name	Title	Selection range	Default
Operation mode for automatic switching			
SYN25_OperA_EPar_	Operation Auto	Off, On, ByPass	On
Enabling/disabling automatic switching			
SYN25_SwOperA_EPar_	SynSwitch Auto	Off,On	On
Energizing mode for automatic switching			
SYN25_EnOperA_EPar_	Energizing Auto	Off, DeadBus LiveLine, LiveBus DeadLine, Any energ case	DeadBus LiveLine

Table 1-8 The enumerated parameters of the evaluation software block for automatic switching

Enumerated parameters for manual switching

Parameter name	Title	Selection range	Default
Operation mode for manual switching			
SYN25_OperM_EPar_	Operation Man	Off, On, ByPass	On
Enabling/disabling manual switching			
SYN25_SwOperM_EPar_	SynSwitch Man	Off,On	On
Energizing mode for manual switching			
SYN25_EnOperM_EPar_	Energizing Man	Off,DeadBus LiveLine, LiveBus DeadLine, Any energ case	DeadBus LiveLine

Tables 1-9 The enumerated parameters of the evaluation software block for manual switching

Integer parameters

Parameter name	Title	Unit	Min	Max	Step	Default
Voltage limit for "live line" detection						
SYN25_LiveU_IPar_	U Live	%	60	110	1	70
Voltage limit for "dead line" detection						
SYN25_DealU_IPar_	U Dead	%	10	60	1	30

Table 1-10 Integer parameters of the evaluation software block

Parameter name	Title	Unit	Min	Max	Step	Default
Voltage difference for automatic synchro checking mode						
SYN25_ChkUdA_IPar_	Udiff SynChk Auto	%	5	30	1	10
Voltage difference for automatic synchro switching mode						
SYN25_SwUdA_IPar_	Udiff SynSW Auto	%	5	30	1	10
Phase difference for automatic switching						
SYN25_MaxPhDiffA_IPar_	MaxPhaseDiff Auto	deg	5	80	1	20

Table 1-11 Integer parameters of the evaluation software block for automatic switching

4.1.4.4. Technical summary

4.1.4.4.1. Technical data

Function	Effective range	Accuracy in the effective range
Rated Voltage U_n	100/200V, parameter setting	
Voltage effective range	10-110 % of U_n	$\pm 1\%$ of U_n
Frequency	47.5 – 52.5 Hz	± 10 mHz
Phase angle		$\pm 3^\circ$
Operate time	Setting value	± 3 ms
Reset time	<50 ms	
Reset ratio	0.95 U_n	

Table 1-16 Technical data of the synchro check / synchro switch function

4.1.4.4.2. Summary of the parameters

Enumerated parameters

Parameter name	Title	Selection range	Default
Selection of the processed voltage			
SYN25_VoltSel_EPar_	Voltage Select	L1-N,L2-N,L3-N,L1-L2,L2-L3,L3-L1	L1-N
Operation mode for automatic switching			
SYN25_OperA_EPar_	Operation Auto	Off, On, ByPass	On
Enabling/disabling automatic switching			
SYN25_SwOperA_EPar_	SynSW Auto	Off, On	On
Energizing mode for automatic switching			
SYN25_EnOperA_EPar_	Energizing Auto	Off, DeadBus LiveLine, LiveBus DeadLine, Any energ case	DeadBus LiveLine
Operation mode for manual switching			
SYN25_OperM_EPar_	Operation Man	Off, On, ByPass	On
Enabling/disabling manual switching			
SYN25_SwOperM_EPar_	SynSW Man	Off, On	On
Energizing mode for manual switching			
SYN25_EnOperM_EPar_	Energizing Man	Off,DeadBus LiveLine, LiveBus DeadLine, Any energ case	DeadBus LiveLine

Tables 1-17 The enumerated parameters of the synchro check / synchro switch function

Integer parameters

Parameter name	Title	Unit	Min	Max	Step	Default
Voltage limit for "live line" detection						
SYN25_LiveU_IPar_	U Live	%	60	110	1	70
Voltage limit for "dead line" detection						
SYN25_DeadU_IPar_	U Dead	%	10	60	1	30
Voltage difference for automatic synchro checking mode						
SYN25_ChkUdA_IPar_	Udiff SynCheck Auto	%	5	30	1	10
Voltage difference for automatic synchro switching mode						
SYN25_SwUdA_IPar_	Udiff SynSW Auto	%	5	30	1	10
Phase difference for automatic switching						
SYN25_MaxPhDiffA_IPar_	MaxPhaseDiff Auto	deg	5	80	1	20
Voltage difference for manual synchro checking mode						
SYN25_ChkUdM_IPar_	Udiff SynCheck Man	%	5	30	1	10
Voltage difference for manual synchro switching mode						
SYN25_SwUdM_IPar_	Udiff SynSW Man	%	5	30	1	10
Phase difference for manual switching						
SYN25_MaxPhDiffM_IPar_	MaxPhaseDiff Man	deg	5	80	1	20

Table 1-18 Integer parameters of the synchro check / synchro switch function

Floating point parameters

Parameter name	Title	Dim.	Min	Max	Default
Frequency difference for automatic synchro checking mode					
SYN25_ChkFrDA_FPar_	FrDiff SynCheck Auto	Hz	0.02	0.5	0.02
Frequency difference for automatic synchro switching mode					
SYN25_SwFrDA_FPar_	FrDiff SynSW Auto	Hz	0.10	1.00	0.2
Frequency difference for manual synchro checking mode					
SYN25_ChkFrDM_FPar_	FrDiff SynCheck Man	Hz	0.02	0.5	0.02
Frequency difference for manual synchro switching mode					
SYN25_SwFrDM_FPar_	FrDiff SynSW Man	Hz	0.10	1.00	0.2

Table 1-19 Floating point parameters of the synchro check / synchro switch function

Timer parameters

Parameter name	Title	Unit	Min	Max	Step	Default
Breaker operating time at closing						
SYN25_CBTTrav_TPar_	Breaker Time	msec	0	500	1	80
Impulse duration for close command						
SYN25_SwPu_TPar_	Close Pulse	msec	10	60000	1	1000
Maximum allowed switching time						
SYN25_MaxSw_TPar_	Max Switch Time	msec	100	60000	1	2000

Table 1-20 Timer parameters of the synchro check / synchro switch function

4.1.4.4.3. Summary of the generated output signals

The **binary output status signals** of the synchro check / synchro switch function are listed in Table 1-21.

Binary status signal	Title	Explanation
SYN25_RelA_Grl_	Release Auto	Releasing the close command initiated by the automatic reclosing function
SYN25_InProgA_Grl_	SynInProgr Auto	Switching procedure is in progress, initiated by the automatic reclosing function
SYN25_UOKA_Grl_	Udiff OK Auto	The voltage difference is appropriate for automatic closing command
SYN25_FrOKA_Grl_	FreqDiff OK Auto	The frequency difference is appropriate for automatic closing command, evaluated for synchro-check **
SYN25_AngOKA_Grl_	Angle OK Auto	The angle difference is appropriate for automatic closing command
SYN25_RelM_Grl_	Release Man	Releasing the close command, initiated by manual closing request
SYN25_InProgM_Grl_	SynInProgr Man	Switching procedure is in progress, initiated by the manual closing command
SYN25_UOKM_Grl_	Udiff OK Man	The voltage difference is appropriate for manual closing command
SYN25_FrOKM_Grl_	FreqDiff OK Man	The frequency difference is appropriate for manual closing command, evaluated for synchro-check **
SYN25_AngOKM_Grl_	Angle OK Man	The angle difference is appropriate for manual closing command

** The frequency is evaluated using the weighted sum of the three phase voltages

Table 1-21 The binary output status signals of the synchro check / synchro switch function

4.1.4.4.4. Summary of the input signals

Binary input status signals

The synchro check / synchro switch function has binary input status signals. **The conditions are defined by the user, applying the graphic equation editor.**

The **binary input status signals** of the synchro check / synchro switch function are listed in Table 1-22.

Binary status signal	Title	Explanation
SYN25_BusSel_GrO_	Bus select	If this signal is logic TRUE, then the voltage of Bus2 is selected for evaluation
SYN25_VTSBlk_GrO_	VTS Block	Blocking signal of the voltage transformer supervision function evaluating the line voltage
SYN25_Bus1VTSBlk_GrO_	VTS Bus1 Block	Blocking signal of the voltage transformer supervision function evaluating the Bus1 voltage
SYN25_Bus2VTSBlk_GrO_	VTS Bus2 Block	Blocking signal of the voltage transformer supervision function evaluating the Bus2 voltage
SYN25_SwStA_GrO_	SySwitch Auto	Switching request signal initiated by the automatic reclosing function
SYN25_CancelA_GrO_	Cancel Auto	Signal to interrupt (cancel) the automatic switching procedure
SYN25_Blk_GrO_	Block	Blocking signal of the function
SYN25_SwStM_GrO_	SySwitch Manual	Switching request signal initiated by manual closing
SYN25_CancelM_GrO_	Cancel Manual	Signal to interrupt (cancel) the manual switching procedure

Table 1-22 The binary input signal of the synchro check / synchro switch function

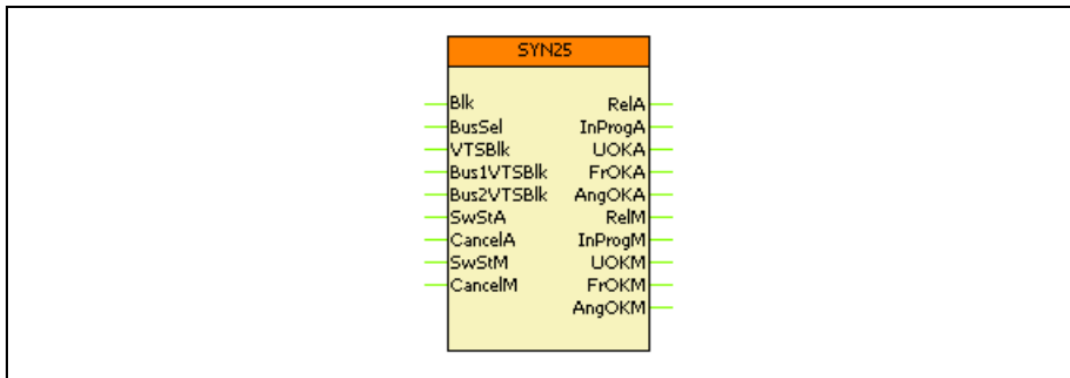

The symbol of the function block in the graphic editor

The names of the input and output signals are parts of the “Binary status signal” names listed in Table 1-21 and Table 1-22.

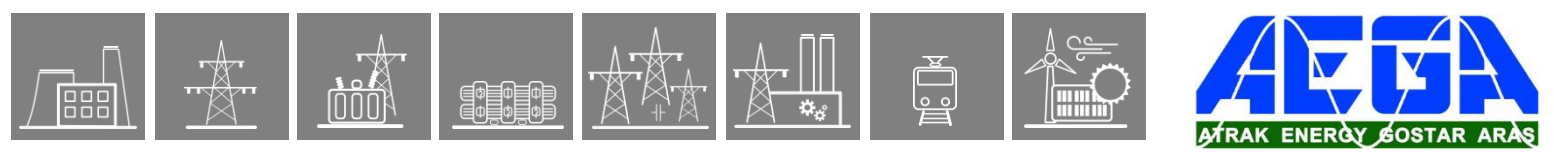

4.1.5. Definite time undervoltage protection function

4.1.5.1. Application

The definite time undervoltage protection function measures three voltages. If any of them is below the level defined by parameter setting value (and above the defined minimum level), then a start signal is generated for the phases individually.

4.1.5.2. Mode of operation

The function generates start signals for the phases individually. The general start signal is set if the voltage in any of the three measured voltages is below the preset parameter setting value (and above the defined minimum level).

Note that in medium voltage applications the function uses the phase-to-phase voltages by default.

The function generates a trip command only if the time delay has expired and the parameter selection requires a trip command as well.

4.1.5.3. Operating characteristics

$$t(G) = t_{OP} \text{ when } G_{min} < G < G_s$$

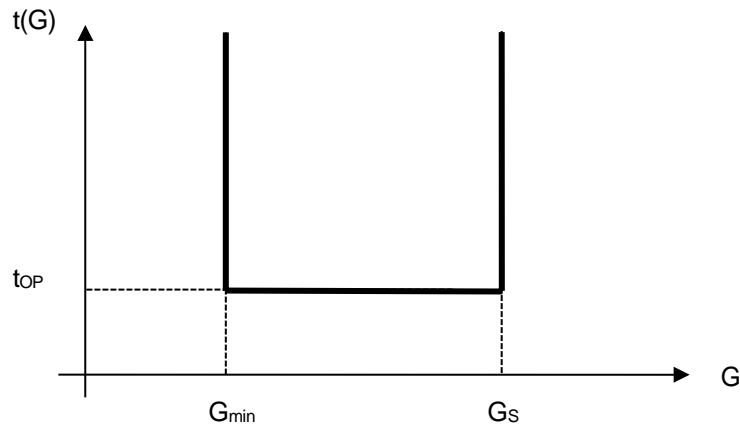

Figure 1-1 Undervoltage independent time characteristic

where

t_{OP} (seconds)

G

G_s

theoretical operating time if $G_{min} < G < G_s$, fix, according to parameter setting value,

measured value of the characteristic quantity, Fourier base harmonic of the phase voltages (or phase-to-phase voltages),

setting value of the characteristic quantity.

4.1.5.4. Structure of the definite time undervoltage protection algorithm

Fig.1-2 shows the structure of the definite time undervoltage protection (TUV27) algorithm.

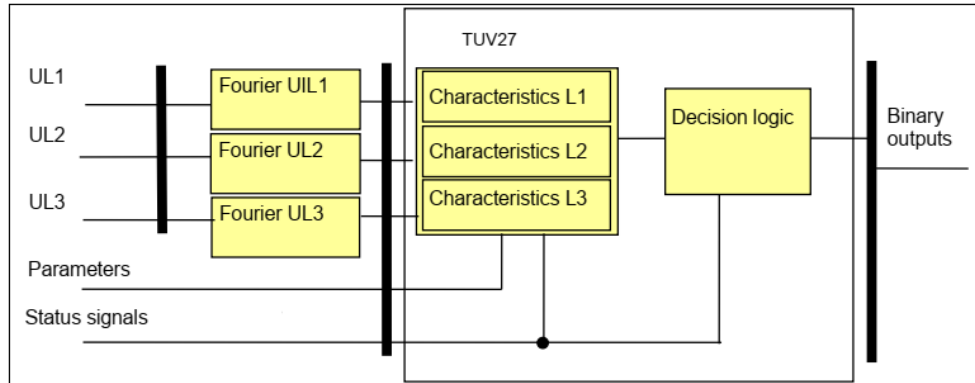

Figure 1-2 Structure of the definite time undervoltage protection algorithm

The **inputs** are

- the RMS values of the fundamental Fourier component of three phase (or phase-to-phase) voltages,
- parameters,
- status signals.

The **outputs** are

- the binary output status signals.

The **software modules** of the differential protection function:

Fourier calculations

These modules calculate the basic Fourier components of the phase voltages individually (not part of the TUV27 function). In medium voltage applications these are changed to phase-to-phase voltages.

Characteristics

This module calculates the required time delay based on the Fourier components of the phase (or phase-to-phase) voltages.

Decision logic

The decision logic module combines the status signals to generate the trip command of the function.

The following description explains the details of the individual components.

4.1.5.5. The Fourier calculation (Fourier)

These modules calculate the basic Fourier components of the phase voltages individually. They are not part of the TUV27 function; they belong to the preparatory phase.

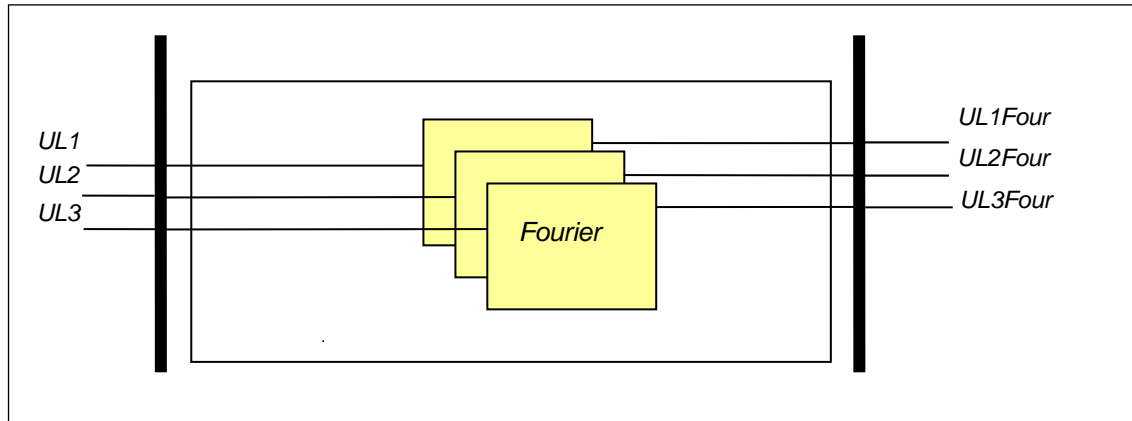

Figure 1-3 Schema of the Fourier calculation

The **inputs** are the sampled values of the three phase voltages (UL1, UL2, UL3)

The **outputs** are the basic Fourier components of the analyzed voltages (UL1Four, UL2Four, UL3Four).

The phase-to-phase voltages (if used) are also calculated here.

4.1.5.6. The definite time characteristics (Characteristics)

This module decides the stating of the function based on the Fourier components of the phase voltages and it counts the time delay. The time delay is defined by the parameter setting, if the voltages are below the setting value.

The **inputs** are the basic Fourier components of the phase (or the calculated phase-to-phase) voltages (UL1Four, UL2Four, UL3Four) and parameters.

The **outputs** are the status signals of the three phases individually. These indicate the started state and the generated trip command if the time delay determined by the setting is expired.

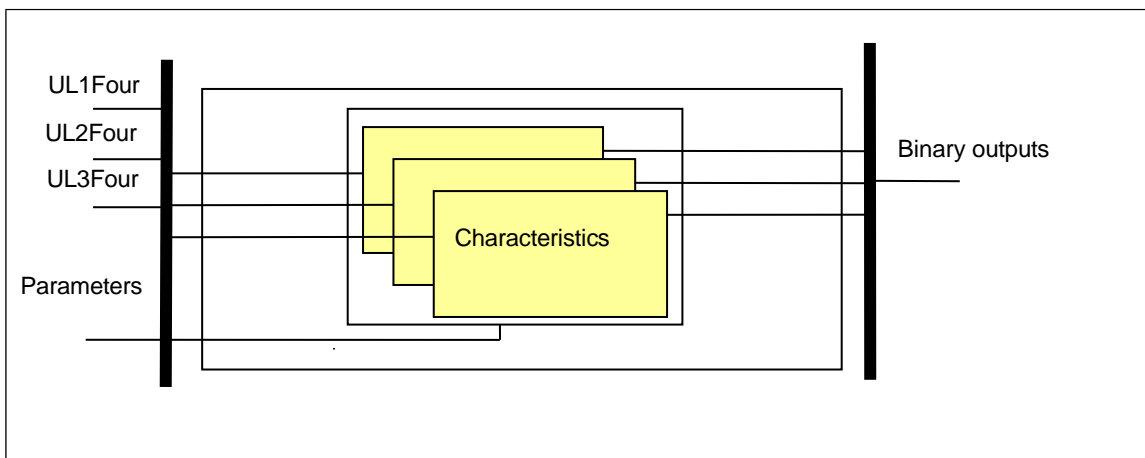

Figure 1-4 Schema of the definite time characteristic calculation

Enumerated parameter

Parameter name	Title	Selection range	Default
Enabling or disabling the undervoltage protection function			
TUV27_Oper_EPar_	Operation	Off, 1 out of 3, 2 out of 3, All	Off

Table 1-1 The enumerated parameter of the undervoltage protection function

Integer parameters

Parameter name	Title	Unit	Min	Max	Step	Default
Starting voltage level setting. If the measured voltage is below the setting value, the function generates a start signal.						
TUV27_StVol_IPar_	Start Voltage	%	30	130	1	90
Blocking voltage level setting. If the measured voltage is below the setting value, the function blocks the start signal.						
TUV27_BlkVol_IPar_	Block Voltage	%	0	20	1	10

Table 1-2 Integer parameters of the undervoltage protection function

Floating point parameter

Parameter name	Title	Unit	Min	Max	Step	Default
Starting voltage level setting. If the measured voltage is below the setting value, the function generates a start signal.						
TUV27_ResetRatio_FPar_	Reset Ratio	%	1	10	1	5

Table 1-3 Floating point parameter of the undervoltage protection function

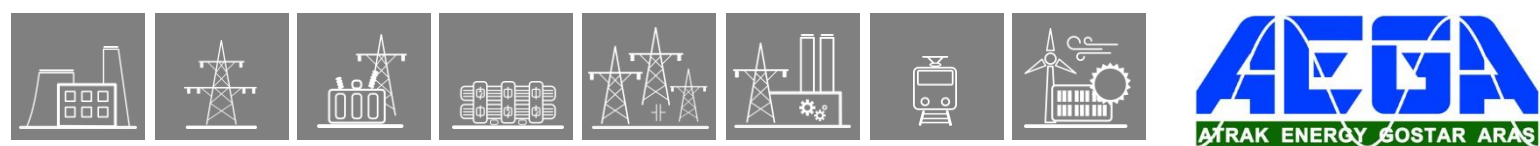

Boolean parameter

Parameter name	Title	Default	Explanation
TUV27_StOnly_BPar_	Start Signal Only	0	Selection if starting and trip signal or starting signal only is to be generated. Set 0 for trip command generation.

Table 1-4 The Boolean parameter of the undervoltage protection function

Timer parameter

Parameter name	Title	Unit	Min	Max	Step	Default
Time delay of the undervoltage protection function.						
TUV27_Delay_TPar_	Time Delay	ms	50	60000	1	100

Table 1-5 Timer parameter of the undervoltage protection function

The **binary output status signals** of the three-phase definite time undervoltage protection function are listed in *Table 1-6*.

Binary output signals	Signal title	Explanation
TUV27_StL1_Grl_	StL1	Starting of the function in phase L1*
TUV27_TrL1_Grl_	TrL1**	Trip command of the function in phase L1*
TUV27_StL2_Grl_	StL2	Starting of the function in phase L2*
TUV27_TrL2_Grl_	TrL2**	Trip command of the function in phase L2*
TUV27_StL3_Grl_	StL3	Starting of the function in phase L3*
TUV27_TrL3_Grl_	TrL3**	Trip command of the function in phase L3*

*In case of phase-to-phase voltages, these are changed to L12, L23, L31 respectively.

**The trip signals are not published for the phases individually

Table 1-6 The binary output status signals of the definite time undervoltage protection function

4.1.5.7. The decision logic (Decision logic)

The decision logic module combines the status signals, binary and enumerated parameters to generate the trip command of the function.

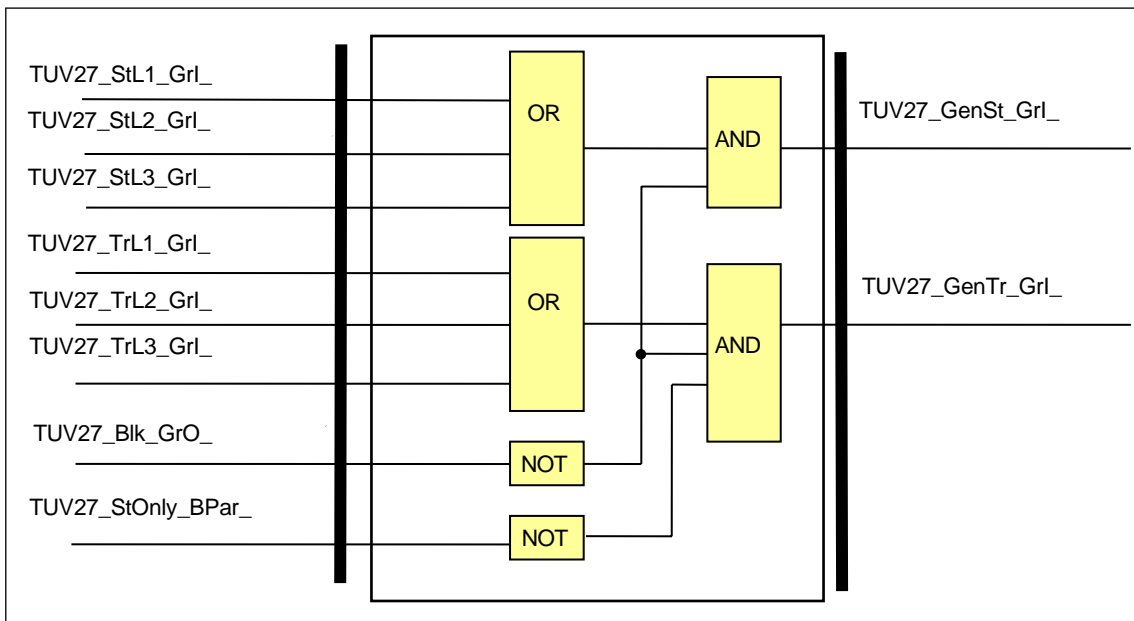

Figure 1-5 The logic scheme of the definite time undervoltage protection function

Binary input signals	Signal title	Explanation
TUV27_StL1_Grl_	StL1	Starting of the function in phase L1*
TUV27_TrL1_Grl_	TrL1**	Trip command of the function in phase L1*
TUV27_StL2_Grl_	StL2	Starting of the function in phase L2*
TUV27_TrL2_Grl_	TrL2**	Trip command of the function in phase L2*
TUV27_StL3_Grl_	StL3	Starting of the function in phase L3*
TUV27_TrL3_Grl_	TrL3**	Trip command of the function in phase L3*

*In case of phase-to-phase voltages, these are changed to L12, L23, L31 respectively.

**The trip signals are not published for the phases individually

Table 1-7 The binary input signals of the definite time undervoltage protection function

Boolean parameter

Parameter name	Title	Default
Enabling start signal only:		
TUV27_StOnly_BPar_	Start Signal Only	FALSE

Table 1-8 The Boolean parameter of the definite time undervoltage protection function

4.1.5.8.2. Binary output status signals

The **binary output status signals** of undervoltage protection function are listed in [Table 1-12](#)

Binary output status signal	Title	Explanation
TUV27_StL1_Grl_	StL1	Start in phase L1*
TUV27_StL2_Grl_	StL2	Start in phase L2*
TUV27_StL3_Grl_	StL3	Start in phase L3*
TUV27_GenSt_Grl_	GenSt	General start signal
TUV27_GenTr_Grl_	GenTr	General trip command

*In case of phase-to-phase voltages, these are changed to L12, L23, L31 respectively.

Table 1-12 The binary output status signals of the undervoltage protection function

4.1.5.8.3. Binary input status signals

Binary input signals

The undervoltage protection function has a binary input signal, which serves the purpose of disabling the function. **The conditions of disabling are defined by the user, applying the graphic equation editor.**

Binary status signal	Title	Explanation
TUV27_BlK_GrO_	Blk	Blocking of the undervoltage protection function

Table 1-13 The binary input signal of undervoltage protection function

4.1.5.8.4. The function block

The function block of undervoltage protection function is shown in [Figure 1-6](#). This block shows all binary input and output status signals that are applicable in the graphic equation editor.

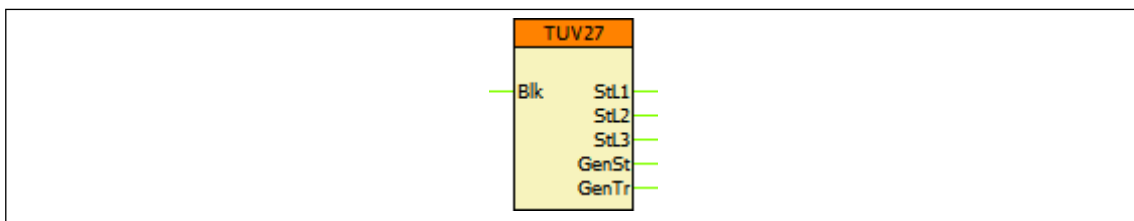

Figure 1-6 The function block of undervoltage protection function

4.1.6. Directional over-power protection function

4.1.6.1. Application

The directional over-power protection function can be applied to protect any elements of the electric power system mainly generators if the active and/or reactive power has to be limited.

4.1.6.2. Mode of operation

The inputs of the function are the Fourier basic harmonic components of the three phase currents and those of the three phase voltages.

Based on the measured voltages and currents, the block calculates the three-phase active and reactive power (point S in Figure 1-1) and compares the P-Q coordinates with the defined characteristics on the power plane. The characteristic is defined as a line laying on the point S_s and perpendicular to the direction of S_s . The S_s point is defined by the “Start power” magnitude and the “Direction angle”. The over-power function operates if the angle of the S- S_s vector related to the directional line is below 90 degrees and above -90 degrees.

At operation, the “Start power” value is decreased by a hysteresis value.

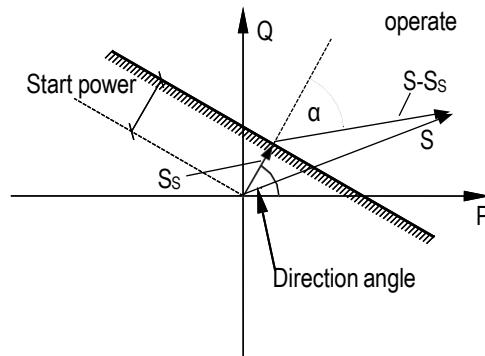

Figure 1-1 The directional over-power decision

4.1.6.3. Structure of the directional over-power protection algorithm

Figure 1-2 shows the structure of the directional over-power protection (DOP32) algorithm.

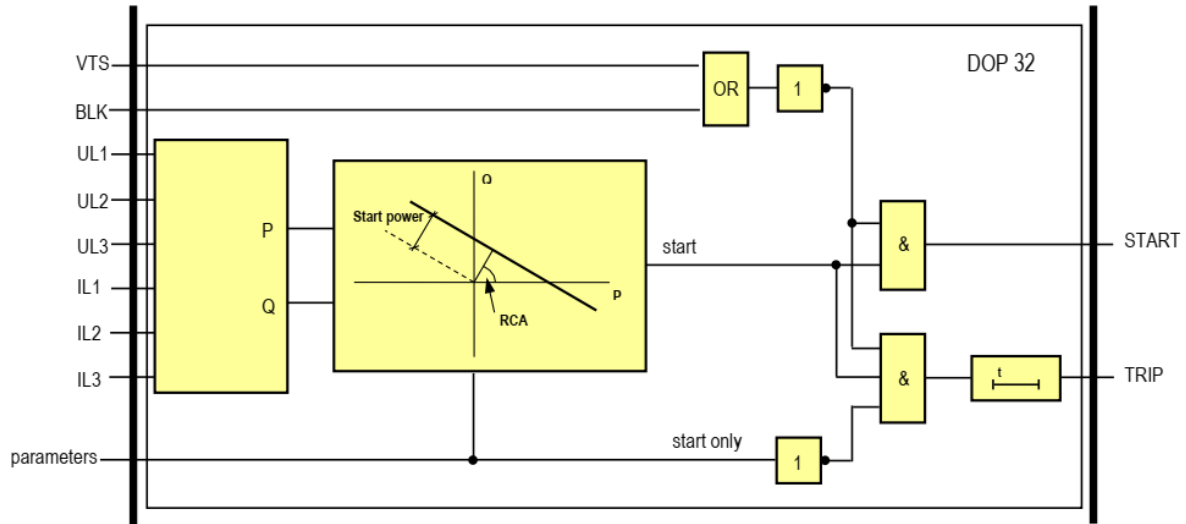

Figure 1-2 Structure of the directional over-power protection algorithm

The **inputs** are

- the RMS value of the fundamental Fourier component of the three phase currents (IL1, IL2, IL3),
- the RMS value of the fundamental Fourier component of the three phase voltages (UL1, UL2, UL3),
- parameters, status signals

The function can be enabled or disabled (Blk). The status signal of the VTS (voltage transformer supervision) function can also disable the directional operation.

The **outputs** are

- the binary output status signals.

The **software modules** of the directional over-power protection function are described in the following chapter.

4.1.6.3.1. P-Q calculation

Based on the RMS values of the fundamental Fourier component of the three phase currents and of the three phase voltages, this module calculates the three-phase active and reactive power values.

The **input signals** are the RMS values of the fundamental Fourier components of the three phase currents and three phase voltages.

The **internal output signals** are the calculated three-phase active and reactive power values.



4.1.6.3.2. Directional decision

This module decides if, on the power plane, the calculated complex power is farther from the origin than the corresponding point of the characteristic line. The operation of this function is explained in Figure 1-1.

The **internal input signals** are the calculated active and reactive power values.

The **internal output signal** is the start signal of the function.

4.1.6.3.3. The decision logic

This part of the function block combines status signals to make a decision to start. Additionally to the directional decision, for the operation, the function must not be blocked by the general “Block” signal, and may not be blocked by the signal “Block for VTS” of the voltage transformer supervision function.

If the parameter setting requires also a trip signal (Start Signal Only = 0), then the measurement of the definite time delay is started. The expiry of this timer results in a trip command.

4.1.6.4. Directional over-power protection function overview

The function block of the directional over-power protection function is shown on the figure below. This block shows all binary input and output status signals that are applicable in the graphic equation editor.

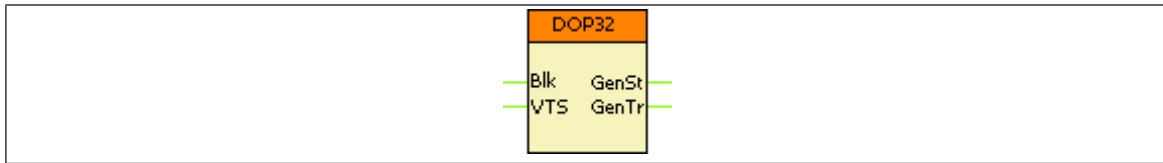

Figure 2-1 The function block of the directional over-power protection function

4.1.6.5. Settings

4.1.6.5.1. Parameters

Table 2-1 Parameters of the over-power protection function

TITLE	DIM	RANGE	STEP	DEFAULT	EXPLANATION
Operation	-	Off, On	-	Off	Enabling the function
Start Signal Only	-	FALSE, TRUE	-	FALSE	Selection: start signal only or both start signal and trip command
Direction Angle	deg	-179 – 180	1	0	Angle which belongs to Start power
Start Power	%	1.0 – 200.0	0.1	10.0	Start power of the function
Time Delay	msec	200 – 60000	1	200	Definite time delay of the trip command

4.1.6.6. Function I/O

This section describes briefly the analogue and digital inputs and outputs of the function block.

4.1.6.6.1. Binary output signals (graphed input statuses)

The binary output status signals of the over-power protection function can be found in the following table. **Parts** written in **bold** are seen on the function block in the logic editor.

Table 2-2 The binary output status signals of the directional over-power protection function

BINARY STATUS SIGNAL	TITLE	EXPLANATION
DOP32_ GenSt _Grl_	General Start	General start signal of the function
DOP32_ GenTr _Grl_	General Trip	Trip command of the function



4.1.6.6.2. Binary input signals (graphed output statuses)

The directional over-power protection function has binary input status signals. **The conditions are defined by the user, applying the graphic equation editor.**

Table 2-3 The binary input status signals of the directional over-power protection function

BINARY STATUS SIGNAL	TITLE	EXPLANATION
DOP32_VTS_GrO_	Block from VTS	Blocking signal from the voltage transformer supervision function
DOP32_Blk_GrO_	Block	General blocking signal

4.1.6.6.3. On-line data

Visible values on the on-line data page:

Table 2-4 On-line data of the directional over-power protection function

SIGNAL TITLE	DIMENSION	EXPLANATION
General Start	-	General start of the function
General Trip	-	General trip command of the function

4.1.6.6.4. Events

The following events are generated in the event list, as well as sent to SCADA according to the configuration.

Table 2-5 Events of the directional over-power protection function

EVENT	VALUE	EXPLANATION
General Start	off, on	General start of the function
General Trip	off, on	General trip command of the function

4.1.6.7. Technical data

Table 2-6 Technical data of the directional over-power protection function

FUNCTION	VALUE	ACCURACY
P, Q measurement	$I > 10\% I_n^*$	< 5%
P, Q measurement with CT1500	$I > 5\% I_n^*$	< 5%
Direction angle	-179 - + 180° *	< 5%
	* = Angle btw. U&I: -70°- +70°	
Reset ratio	0,95	
Reset time	< 100 ms	
Operating time	< 125 ms	
Time delay	0.2 – 60 s	1% or ± 25 ms

4.1.6.7.1. Notes for testing

Normally in the EuroProt+ devices the trip contacts are assigned to the Trip Logic function block, and not to the protection function blocks. Because of this, the testing personnel must make sure that the Trip Logic is switched on ('Operation' parameter is set to other than 'Off') before starting the testing, otherwise there will be no physical trip on the relay.

The function is based on the power measurement of the Line Measurement function block. This must be taken into consideration when the device has a separate CT for measurements, because with it, the over-power protection function will use that CT as well.

4.1.7.3. Structure of the directional under-power protection algorithm

Figure 1-2 shows the structure of the directional under-power protection (DUP32) algorithm.

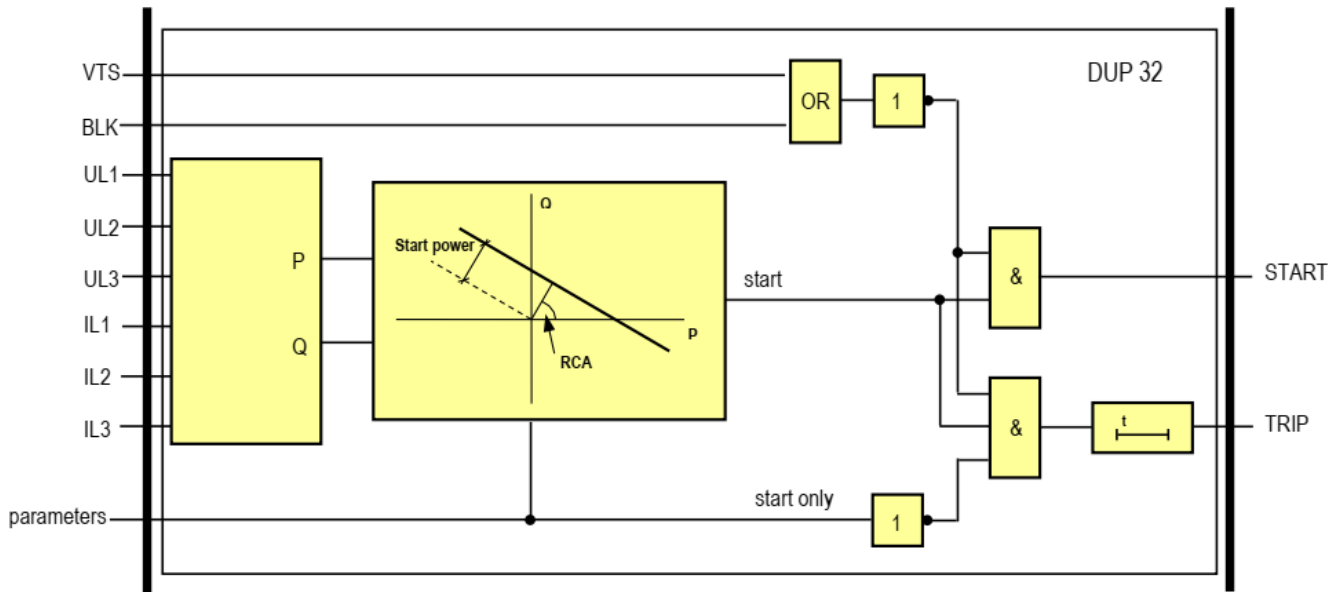

Figure 1-2 Structure of the directional under-power protection algorithm

The **inputs** are

- the RMS value of the fundamental Fourier component of the three phase currents (IL1, IL2, IL3),
- the RMS value of the fundamental Fourier component of the three phase voltages (UL1, UL2, UL3),
- parameters,
- status signals.

The function can be enabled or disabled (BLK input signal). The status signal of the VTS (voltage transformer supervision) function can also disable the directional operation.

The **outputs** are

- the binary output status signals.

The **software modules** of the directional under-power protection function are described in the following chapters.

4.1.7.3.1. P-Q calculation

Based on the RMS values of the fundamental Fourier component of the three phase currents and of the three phase voltages, this module calculates the three-phase active and reactive power values.

The **input signals** are the RMS values of the fundamental Fourier components of the three phase currents and three phase voltages.

The **internal output signals** are the calculated three-phase active and reactive power values.

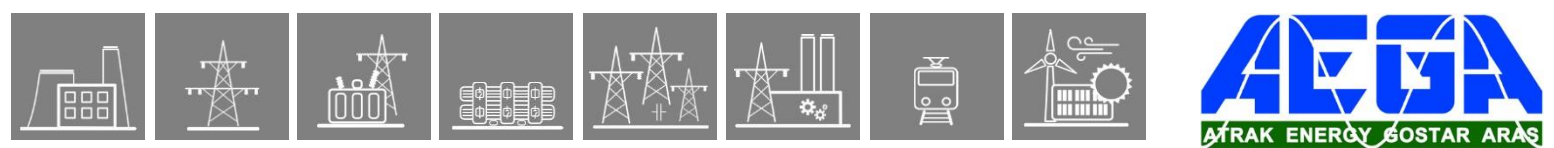

4.1.7.3.2. Directional decision

This module decides if, on the power plane, the calculated complex power is closer to the origin than the corresponding point of the characteristic line, i.e. if the point S is on the “Operate” side of the P-Q plane. The operation of this function is explained in Figure 1-1.

The **internal input signals** are the calculated active and reactive power values.

The **internal output signal** is the start signal of the function.

4.1.7.3.3. The decision logic

This part of the function block combines status signals to make a decision to start. Additionally to the directional decision, for the operation, the function must not be blocked by the general “Block” signal, and may not be blocked by the signal “Block for VTS” of the voltage transformer supervision function.

If the parameter setting requires also a trip signal (Start Signal Only = 0), then the measurement of the definite time delay is started. The expiry of this timer results in a trip command.

4.1.7.4. Directional under-power protection function overview

The function block of the directional under-power protection function is shown on the figure below. This block shows all binary input and output status signals that are applicable in the graphic equation editor.

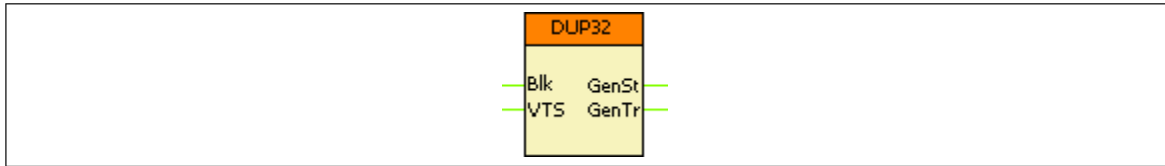

Figure 2-1 The function block of the directional under-power protection function

4.1.7.4.1. Settings

4.1.7.4.1.1. Parameters

Table 2-1 Parameters of the under-power protection function

TITLE	DIM	RANGE	STEP	DEFAULT	EXPLANATION
Operation	-	Off, On	-	Off	Enabling the function
Start Signal Only	-	FALSE, TRUE	-	FALSE	Selection: start signal only or both start signal and trip command
Direction Angle	deg	-179 – 180	1	0	Angle which belongs to Start power
Start Power	%	1.0 – 200.0	0.1	10.0	Start power of the function
Time Delay	msec	200 – 60000	1	200	Definite time delay of the trip command

4.1.7.4.2. Function I/O

This section describes briefly the analogue and digital inputs and outputs of the function block.

4.1.7.4.2.1. Binary output signals (graphed input statuses)

The binary output status signals of the under-power protection function can be found in the following table. **Parts** written in **bold** are seen on the function block in the logic editor.

Table 2-2 The binary output status signals of the directional under-power protection function

BINARY STATUS SIGNAL	TITLE	EXPLANATION
DUP32_ GenSt _Grl_	General Start	General start signal of the function
DUP32_ GenTr _Grl_	General Trip	Trip command of the function

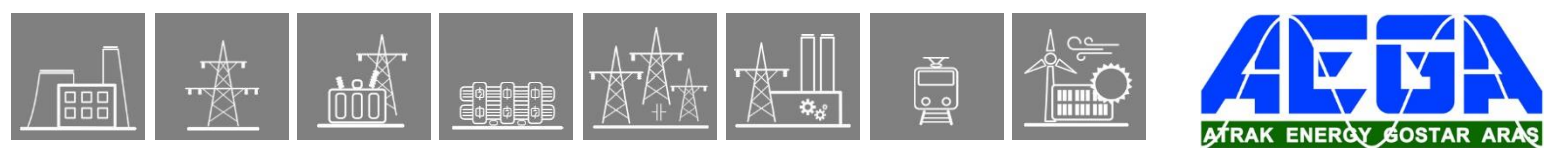

4.1.7.4.2.2. Binary input signals (graphed output statuses)

The directional under-power protection function has binary input status signals. **The conditions are defined by the user, applying the graphic equation editor.**

Table 2-3 The binary input status signals of the directional under-power protection function

BINARY STATUS SIGNAL	TITLE	EXPLANATION
DUP32_VTS_GrO_	Block from VTS	Blocking signal from the voltage transformer supervision function
DUP32_Blk_GrO_	Block	General blocking signal

4.1.7.4.2.3. On-line data

Visible values on the on-line data page:

Table 2-4 On-line data of the directional under-power protection function

SIGNAL TITLE	DIMENSION	EXPLANATION
General Start	-	General start of the function
General Trip	-	General trip command of the function

4.1.7.4.2.4. Events

The following events are generated in the event list, as well as sent to SCADA according to the configuration.

Table 2-5 Events of the directional under-power protection function

EVENT	VALUE	EXPLANATION
General Start	off, on	General start of the function
General Trip	off, on	General trip command of the function

4.1.8. Negative sequence overcurrent protection function

The negative sequence overcurrent protection function (TOC46) block operates if the negative sequence current is higher than the preset starting value.

In the negative sequence overcurrent protection function, definite-time or inverse-time characteristics are implemented, according to IEC or IEEE standards. The function evaluates a single measured current, which is the RMS value of the fundamental Fourier component of the negative sequence current. The characteristics are harmonized with IEC 60255-151, Edition 1.0, 2009-08.

4.1.8.1. Operating characteristics

4.1.8.1.1. Definite time characteristic

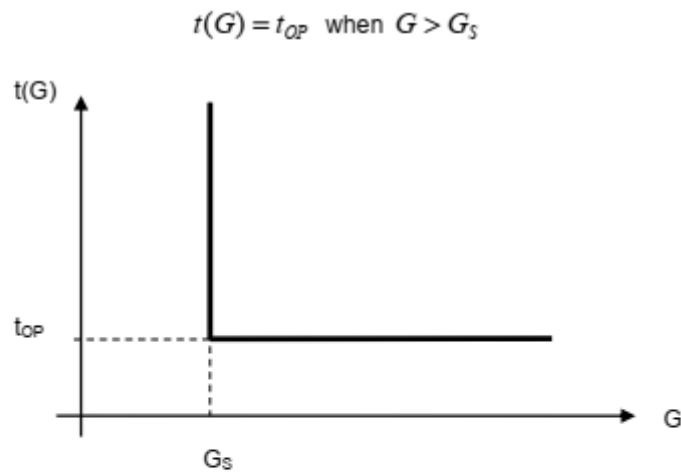

Figure 1-1 Overcurrent definite time characteristic

where	
t_{OP} (seconds)	theoretical operating time if $G > G_s$, fix, according to the preset parameter,
G	measured value of the characteristic quantity, Fourier base harmonic of the negative sequence current,
G_s	preset starting value of the characteristic quantity (TOC46_StCurr_IPar_, Start current).

4.1.8.1.2. Standard dependent time characteristics

Operating characteristics:

$$t(G) = TMS \left[\frac{k}{\left(\frac{G}{G_s}\right)^\alpha - 1} + c \right] \text{ when } G > G_s$$

where
 t(G)(seconds) theoretical operate time with constant value of G,
 k, c constants characterizing the selected curve (in seconds),
 α constant characterizing the selected curve (no dimension),
 G measured value of the characteristic quantity, Fourier base harmonic of the negative sequence current (INFour),
 G_s preset value of the characteristic quantity (TOC46_StCurr_IPar_, Start current),
 TMS preset time multiplier (no dimension).

	IEC ref		k _r	c	α
1	A	IEC Inv	0,14	0	0,02
2	B	IEC VeryInv	13,5	0	1
3	C	IEC ExtInv	80	0	2
4		IEC LongInv	120	0	1
5		ANSI Inv	0,0086	0,0185	0,02
6	D	ANSI ModInv	0,0515	0,1140	0,02
7	E	ANSI VeryInv	19,61	0,491	2
8	F	ANSI ExtInv	28,2	0,1217	2
9		ANSI LongInv	0,086	0,185	0,02
10		ANSI LongVeryInv	28,55	0,712	2
11		ANSI LongExtInv	64,07	0,250	2

Table 1-1 The constants of the standard dependent time characteristics

The end of the effective range of the dependent time characteristics (G_D) is:

$$G_D = 20 * G_s$$

Above this value the theoretical operating time is definite:

$$t(G) = TMS \left[\frac{k}{\left(\frac{G_D}{G_s}\right)^\alpha - 1} + c \right] \text{ when } G > G_D = 20 * G_s$$

The inverse characteristic is valid above G_T = 1,1 * G_s. Above this value the function is guaranteed to operate.

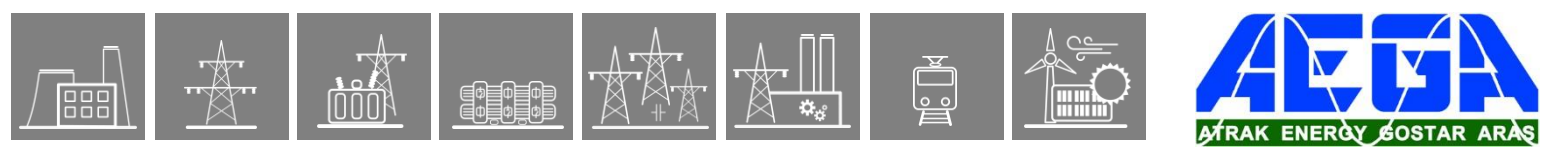

Resetting characteristics:

$$t_r(G) = TMS \left[\frac{k_r}{1 - \left(\frac{G}{G_s}\right)^\alpha} \right] \text{ when } G < G_s$$

where
 $t_r(G)$ (seconds) theoretical reset time with constant value of G,
 k_r constants characterizing the selected curve (in seconds),
 α constant characterizing the selected curve (no dimension),
 G measured value of the characteristic quantity, Fourier base harmonic of the phase current,
 G_s preset starting value of the characteristic quantity (TOC51_StCurr_IPar_, Start current),
 TMS preset time multiplier (no dimension).

	IEC ref		k_r	α
1	A	IEC Inv	Resetting after fix time delay, according to preset parameter	
2	B	IEC VeryInv		
3	C	IEC ExtInv	TOC46_Reset_TPar_	
4		IEC LongInv	"Reset delay"	
5		ANSI Inv	0,46	2
6	D	ANSI ModInv	4,85	2
7	E	ANSI VeryInv	21,6	2
8	F	ANSI ExtInv	29,1	2
9		ANSI LongInv	4,6	2
10		ANSI LongVeryInv	13,46	2
11		ANSI LongExtInv	30	2

Table 1-2 The resetting constants of the standard dependent time characteristics

The inverse type characteristics are also combined with a minimum time delay, the value of which is set by user parameter TOC46_MinDel_TPar_ (Min. Time Delay).

4.1.8.2. Structure of the negative sequence overcurrent protection algorithm

Fig.1-1 shows the structure of the negative sequence overcurrent protection (TOC46) algorithm.

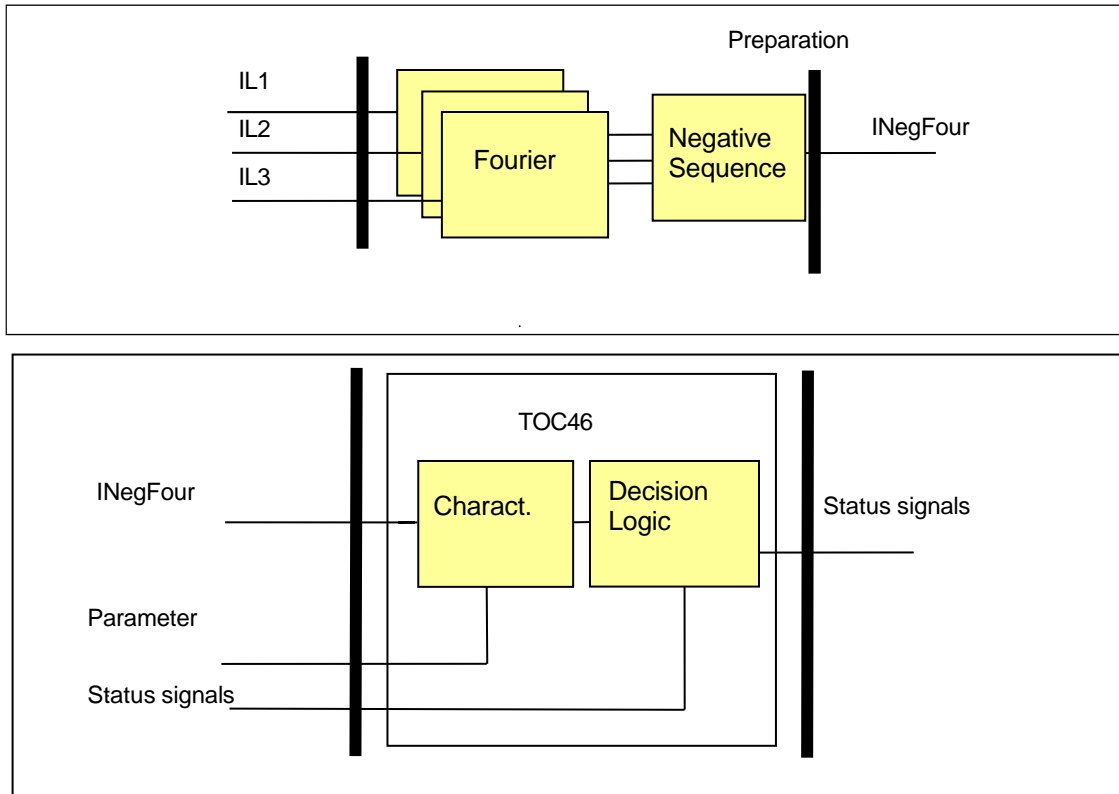

Figure 1-1 Structure of the negative sequence overcurrent protection algorithm

For the preparation (not part of the TOC46 function):

The **inputs** are

- the sampled values of the three phase currents (IL1, IL2, IL3),

The **output** is

- the RMS value of the fundamental Fourier components of the negative sequence component of the phase currents.

For the TOC46 function:

The **inputs** are

- the RMS value of the fundamental Fourier component of the negative sequence component of the phase currents,
- parameters,
- status signals.

The **outputs** are

- the binary output status signals.

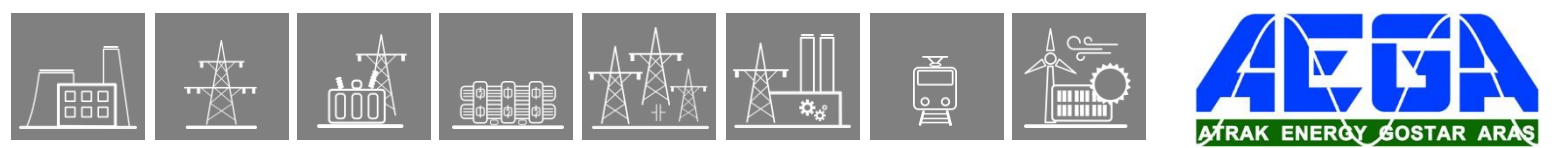

The **software modules** applied in the negative sequence overcurrent protection function are:

Fourier calculations

These modules calculate the basic Fourier current components of the phase currents.

Negative sequence

This module calculates the basic Fourier current components of the negative sequence current, based on the Fourier components of the phase currents.

Characteristics

This module calculates the required time delay based on the Fourier components of the negative sequence current.

Decision logic

The decision logic module combines the status signals to generate the trip command of the function.

The following description explains the details of the individual components.

4.1.8.3. The Fourier calculation (Fourier)

These modules calculate the basic Fourier current components of the phase currents individually. These modules belong to the preparatory phase.

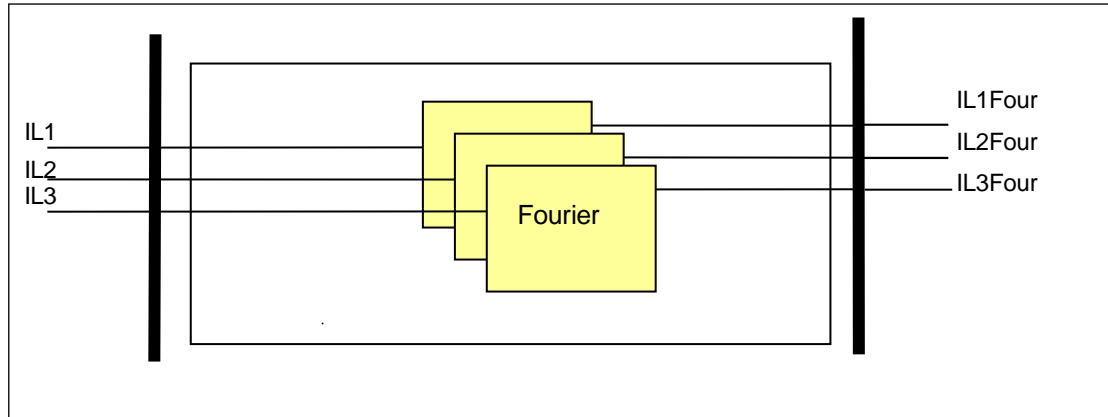
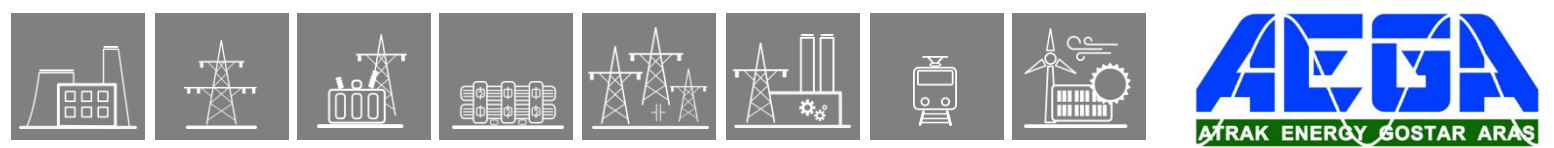

Figure 1-2 Schema of the Fourier calculation

The **inputs** are the sampled values of:
The three phase currents of the primary side (IL1, IL2, IL3)

The **outputs** are the basic Fourier components of the analyzed currents (IL1Four, IL2Four, IL3Four).



4.1.8.4. The negative phase sequence calculation (Negative sequence)

This module calculates the negative phase sequence components based on the Fourier components of the phase currents. This module belongs to the preparatory phase.

The **inputs** are the basic Fourier components of the phase currents (IL1Four, IL2Four, IL3Four).

The **output** is the basic Fourier component of the negative sequence current component (INegFour).

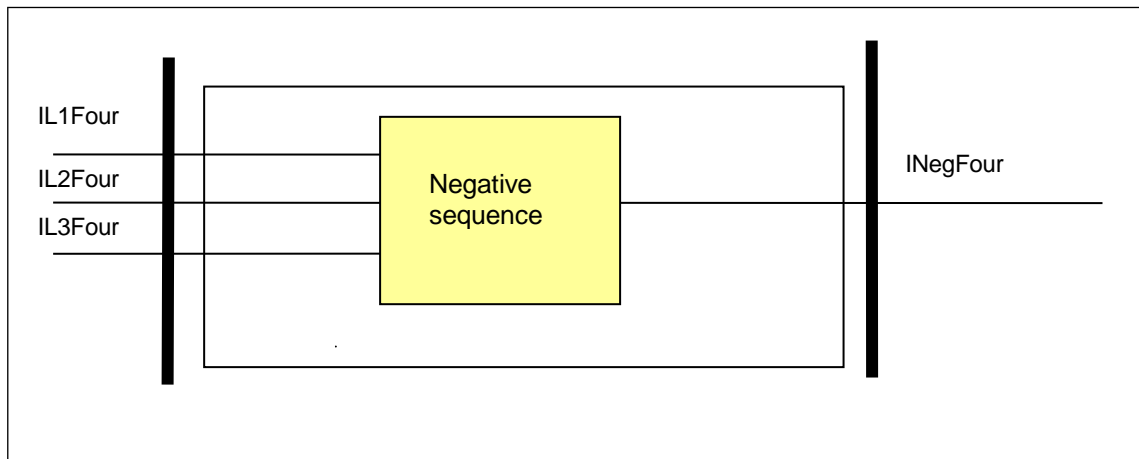

Figure 1-3 Schema of the negative sequence component calculation

4.1.8.5. The definite time and the inverse type_characteristics (Characteristics)

This module calculates the required time delay based on the Fourier components of the negative sequence current. The formulas applied are described in Chapter 1.1.

The **input** is the basic Fourier component of the negative sequence current (INegFour) and parameters.

The **outputs** are the internal status signals of the function. These indicate the started state and the generated trip command if the time delay determined by the characteristics expired.

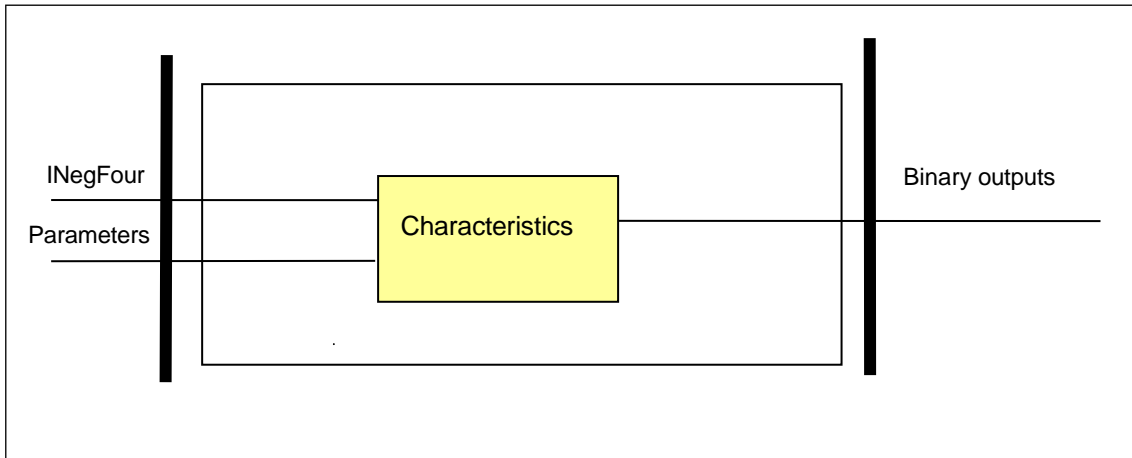

Figure 1-4 Schema of the characteristic calculation

Enumerated parameter

Parameter name	Title	Selection range	Default
Parameter for type selection			
TOC46_Oper_EPar_	Operation	Off, DefinitTime, IEC Inv, IEC VeryInv, IEC ExtInv, IEC LongInv, ANSI Inv, ANSI ModInv, ANSI VeryInv, ANSI ExtInv, ANSI LongInv, ANSI LongVeryInv, ANSI LongExtInv	Off

Table 1-3 The enumerated parameters of the negative sequence overcurrent protection function

Integer parameter

Parameter name	Title	Unit	Min	Max	Step	Default
Starting current parameter:						
TOC46_StCurr_IPar_	Start Current	%	10	1000	1	50

Table 1-4 The integer parameters of the negative sequence overcurrent protection function

4.1.8.6. The decision logic (Decision logic)

The decision logic module combines the binary status signals to generate the trip command of the function.

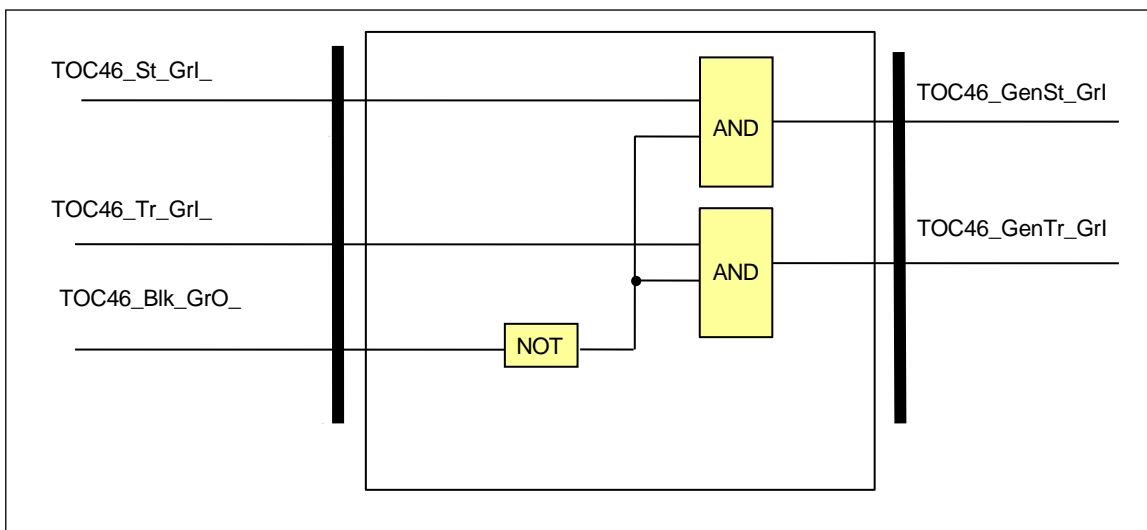

Figure 1-5 The logic scheme of the negative sequence overcurrent protection function

Binary status signals	Signal title	Explanation
TOC46_St_Grl_	Start	Starting of the function
TOC46_Tr_Grl_	Trip	Trip command of the function

Table 1-8 The binary status signals of the decision logic

Binary input status signal

The negative sequence overcurrent protection function has a binary input signal, which serves the purpose of disabling the function. **The conditions of disabling are defined by the user, applying the graphic equation editor.**

Binary input status signal	Explanation
TOC46_BlK_GrO_	Output status of a graphic equation defined by the user to disable the negative sequence overcurrent protection function.

Table 1-9 The binary input signal of the negative sequence overcurrent protection function

Binary output signals	Signal title	Explanation
TOC46_GenSt_Grl_	General Start	General starting of the function
TOC46_GenTr_Grl_	General Trip	General trip command of the function

Table 1-10 The binary output status signals of the negative sequence overcurrent protection function

4.1.8.7. Technical summary

4.1.8.7.1. Technical data

Function	Value	Accuracy
Operating accuracy	$10 \leq G_s [\%] \leq 200$	< 2 %
Operate time accuracy		$\pm 5\%$ or ± 15 ms, whichever is greater
Reset ratio	0,95	
Reset time * Dependent time charact. Definite time charact.	approx. 60 ms	<2 % or ± 35 ms, whichever is greater
Transient overreach		< 2 %
Pickup time at $2 \cdot G_s$	<40 ms	
Overshot time Dependent time charact. Definite time charact.	25 ms 45 ms	
Influence of time varying value of the input current (IEC 60255-151)		< 4 %

Measured with signal contacts

Table 1-11 Technical data of the negative sequence overcurrent protection function

4.1.8.7.2. The parameters

The parameters are summarized in Chapter 3.1.1.5.

4.1.8.7.3. Binary output status signals

The **binary output status signals** of the negative sequence overcurrent protection function are listed in Table 1-12.

Binary output signals	Signal title	Explanation
TOC46_GenSt_Grl_	General Start	General starting of the function
TOC46_GenTr_Grl_	General Trip	General trip command of the function

Table 1-12 The binary output status signals of the negative sequence overcurrent protection function

4.1.8.7.4. The binary input status signals

Binary input signals

The negative sequence overcurrent protection function has a binary input signal, which serves the purpose of disabling the function. **The conditions of disabling are defined by the user, applying the graphic equation editor.**

Binary input signal	Explanation
TOC46_Blkc_GrO_	Output status of a graphic equation defined by the user to disable the negative sequence overcurrent protection function.

Table 1-13 The binary input signal of the negative sequence overcurrent protection function

4.1.8.7.5. The function block

The function block of the negative sequence overcurrent protection function is shown in Figure 1-6. This block shows all binary input and output status signals that are applicable in the graphic equation editor.

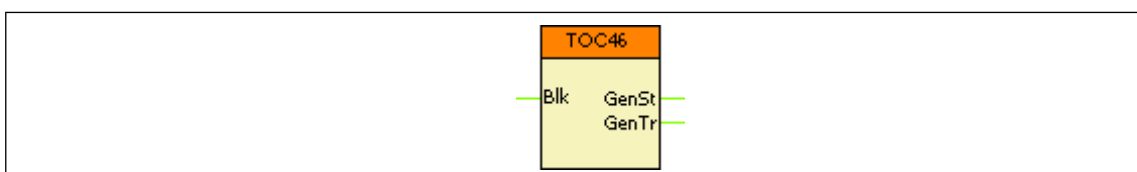
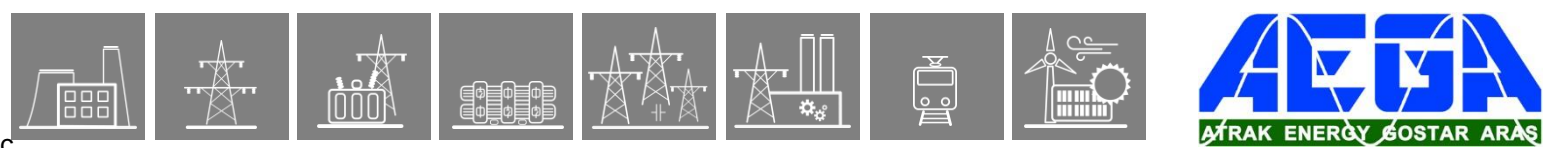

Figure 1-6 The function block of the negative sequence overcurrent protection function



The **software modules** of the broken conductor function:

Fourier calculations

These modules calculate the RMS values of the basic Fourier current components of the phase currents individually (not part of the PBC46 function).

Positive and negative sequence

This module calculates the basic Fourier current components of the positive and negative sequence currents, based on the Fourier components of the phase currents (not part of the PBC46 function).

Analogue signal processing

This module processes the positive and negative phase sequence current components to prepare the signals for the decision.

Decision logic

The decision logic module combines the status signals to generate the starting signal and the trip command of the function.

The following description explains the details of the individual components.

4.1.9.1.3. The Fourier calculation (Fourier)

These modules calculate the RMS values of the fundamental Fourier components of the phase currents individually. They are not part of the PBC46 function; they belong to the preparatory phase.

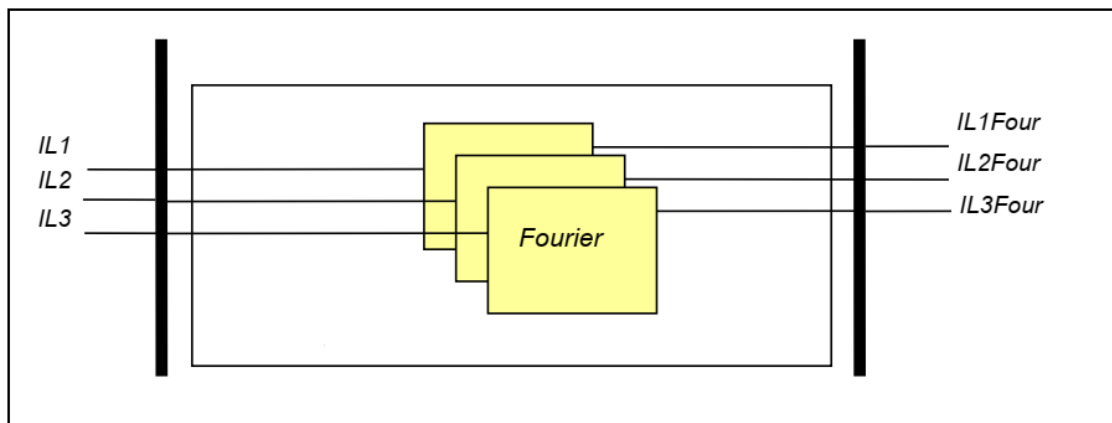
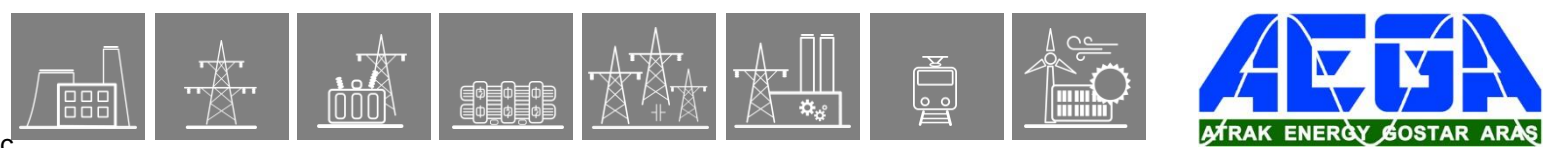

Figure 1-2 Principal scheme of the Fourier calculation

The **inputs** are the sampled values of the three phase currents (IL1, IL2, IL3)

The **outputs** are the RMS values of the fundamental Fourier components of the phase currents (IL1Four, IL2Four, IL3Four).



4.1.9.1.4. The positive and negative phase sequence calculation (Positive and negative sequence)

This module calculates the positive and negative phase sequence components based on the Fourier components of the phase currents. This module belongs to the preparatory phase.

The **inputs** are the basic Fourier components of the phase currents (IL1Four, IL2Four, IL3Four).

The **outputs** are the basic Fourier components of the positive (IPosFour) and negative sequence current component (INegFour).

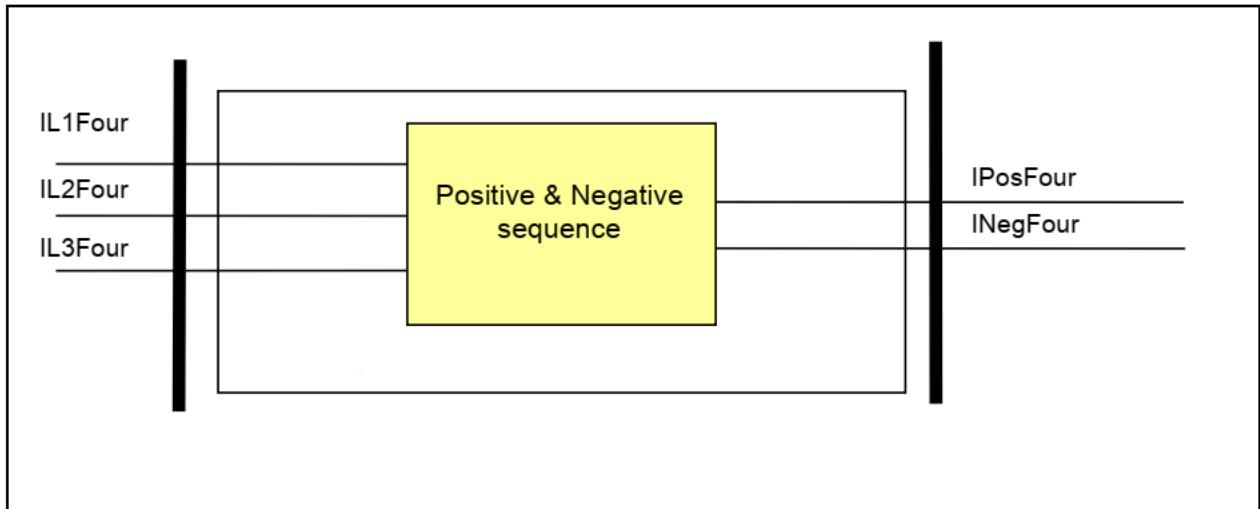

Figure 1-3 Schema of the sequence component calculation

4.1.9.1.5. The Analogue signal processing

This module processes the Fourier components of the phase currents to prepare the signals for the decision.

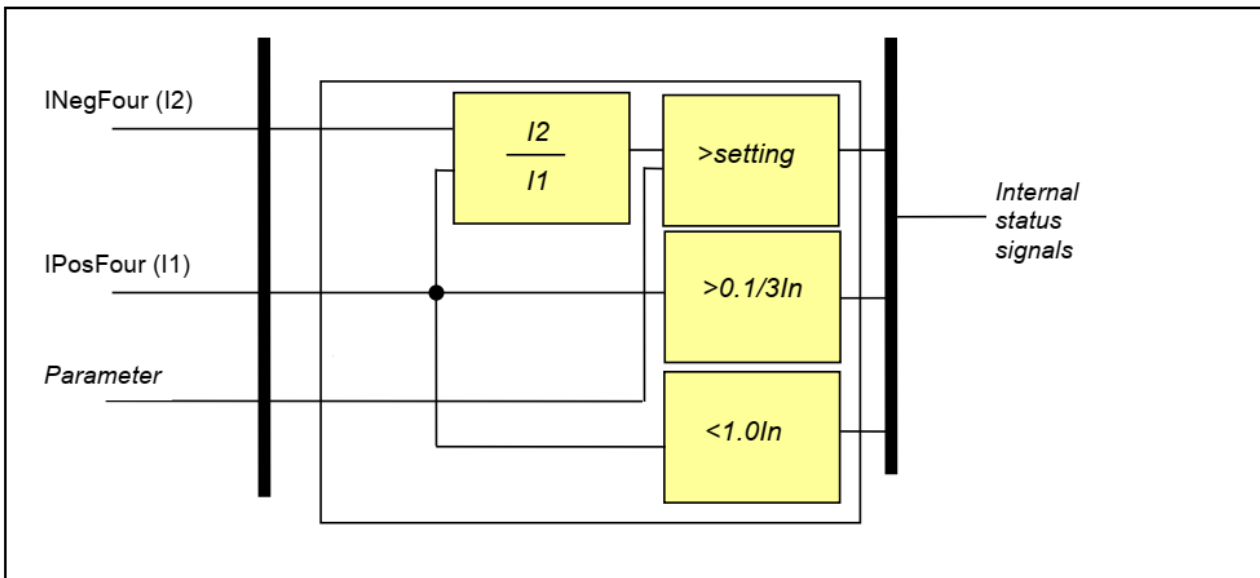
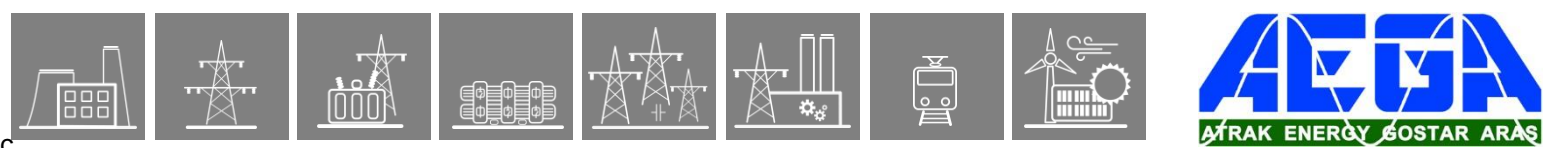

Figure 1-4 Principal scheme of the analogue signal processing



The **inputs** are the basic Fourier component of the positive (IPosFour) and negative sequence currents (INegFour) and parameters.

The **outputs** are internal binary signals:

- $I2/I1 >$ the ratio of negative sequence current (I2) to positive sequence current (I1) as a percentage is above the limit defined by the preset parameter PBC46_StCurr_IPar_ (Start current);
- $I1 > 0.1/3I_n$ the positive phase sequence current (I1) value of the fundamental Fourier components of the phase currents is sufficient for evaluation;
- $I1 < 1.0I_n$ the positive phase sequence current (I1) value of the fundamental Fourier components of the phase currents is sufficient for evaluation.

4.1.9.1.6. The decision logic (Decision logic)

The decision logic module combines the status signals, binary and enumerated parameters to generate the trip command of the function.

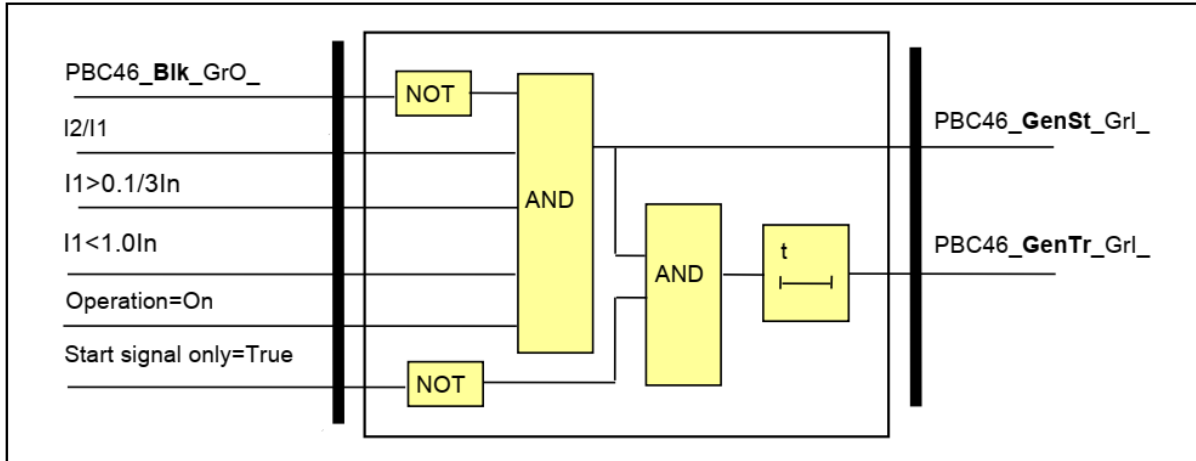

Figure 1-5 The logic scheme of the broken conductor function

The **inputs** are internal binary signals:

- $I2/I1 >$ the ratio of positive phase sequence current ($I1$) to negative phase sequence current ($I2$) as a percentage is above the limit defined by the preset parameter "Start current";
- $I1 > 0.1/3I_n$ the positive phase sequence current ($I1$) value of the fundamental Fourier components of the phase currents is sufficient for evaluation;
- $I1 < 1.0I_n$ the positive phase sequence current ($I1$) value of the fundamental Fourier components of the phase currents is sufficient for evaluation.

4.1.9.2. Broken conductor protection function overview

The graphic appearance of the function block of the broken conductor protection function is shown below. The block shows all binary input and output status signals which are applicable in the graphic equation editor.

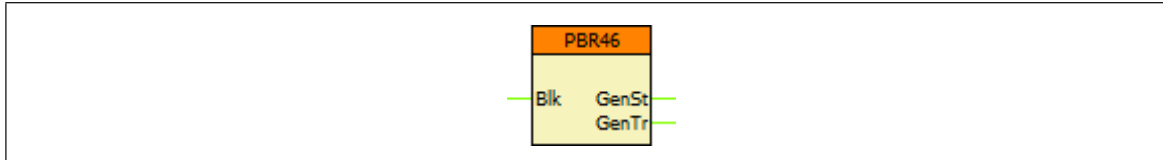

Figure 2-1 Graphic appearance of the function block of the broken conductor protection function

4.1.9.3. Settings

4.1.9.3.1. Parameters

The available parameters are listed below in order of their appearance in the *parameters* menu. If the setting range of a parameter should be extended, contact Protecta Support.

Table 2-1 Parameters of the broken conductor protection function

TITLE	DIM	RANGE	STEP	DEFAULT	EXPLANATION
Operation	-	Off, On	-	Off	Enabling the function
Start Signal Only	-	FALSE, TRUE	-	FALSE	When checked, the function provides start signal, but no trip signal.
Start Current	%	10 – 90	1	50	I2/I1 ratio setting
Time Delay	msec	100 – 60000	1	1000	Time delay (including the algorithm time, see Chapter 2.4 for more explanation)

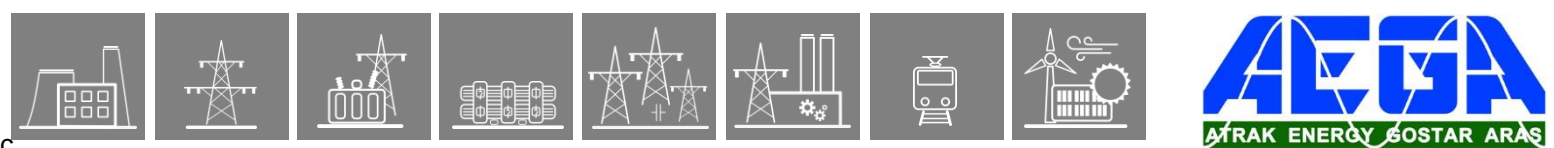

4.1.9.4. Function I/O

This section describes briefly the analogue and digital inputs and outputs of the function block.

4.1.9.4.1. Analogue inputs

The function uses the sampled values of a current input. This is defined in the configuration.

4.1.9.4.2. Binary input signals (graphed output statuses)

The conditions of the binary inputs are defined by the user, applying the graphic equation editor (*Logic Editor*). Parts written in **bold** are seen on the left side function block in the Logic editor.

Table 2-2 The binary input signal of the broken conductor protection function

BINARY OUTPUT SIGNAL	EXPLANATION
PBC46_ Blk _GrO_	Blocking input of the function

4.1.9.4.3. Binary output signals (graphed input statuses)

These signals can be used in EuroCAP to assign to LED, user LCD object etc. Parts written in **bold** are seen on the right side of the function block in the *Logic Editor*.

Table 2-3 The binary output signals of the broken conductor protection function

BINARY OUTPUT SIGNAL	SIGNAL TITLE	EXPLANATION
PBC46_ GenSt _Grl_	General Start	General start signal of the function
PBC46_ GenTr _Grl_	General Trip	General trip command of the function

4.1.9.4.4. Online data

Visible values on the *online data* page.

Table 2-4 Online displayed data of the broken conductor protection function

SIGNAL TITLE	DIMENSION	EXPLANATION
General Start	-	General start signal of the function
General Trip	-	General trip command of the function

4.1.9.4.5. Events

The following events are generated in the event list, as well as sent to the SCADA according to the configuration.

Table 2-5 Generated events of the broken conductor protection function

EVENT	VALUE	EXPLANATION
General Start	off, on	General start of the function
General Trip	off, on	General trip command of the function

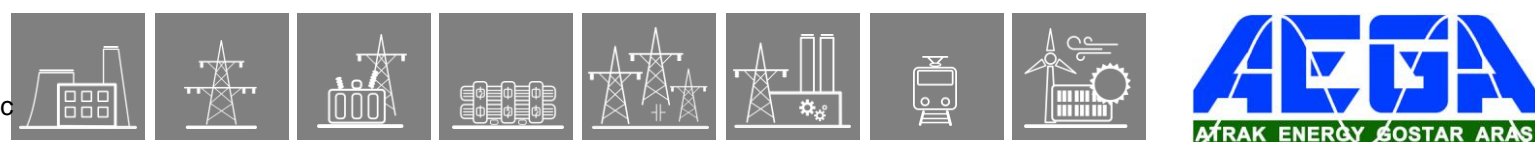

4.1.9.5. Technical data

Table 2-6 Technical data of the broken conductor protection function

FUNCTION	VALUE	ACCURACY
Pick-up starting accuracy		< 2 %
Reset ratio	0,95	
Min. operate time	70 ms	

4.1.9.6. Notes for testing

Normally in the EuroProt+ devices the trip contacts are assigned to the Trip Logic function block, and not to the protection function blocks. Because of this, the testing personnel must make sure that the Trip Logic is switched on ('Operation' parameter is set to other than 'Off') before starting the tests, otherwise there will be no physical trip on the relay.

Note that the time delay parameter incorporates the algorithm time as well, so the time delay **does not mean the time difference between the appearance of the start and trip signals** of the function. In other words: it is not the delay between the detection of the fault and the trip that follows it. This should be taken into consideration when checking the disturbance records.

Instead the time delay parameter defines the elapsed time from the appearance of the faulty state to the trip. Because of this, while testing, the delay measurement should start *from the moment of the fault injection* until the trip signal.

4.1.10.4. Structure of the negative sequence definite time overvoltage protection algorithm

Fig.1-2 shows the structure of the negative sequence definite time overvoltage protection (TOV47) algorithm.

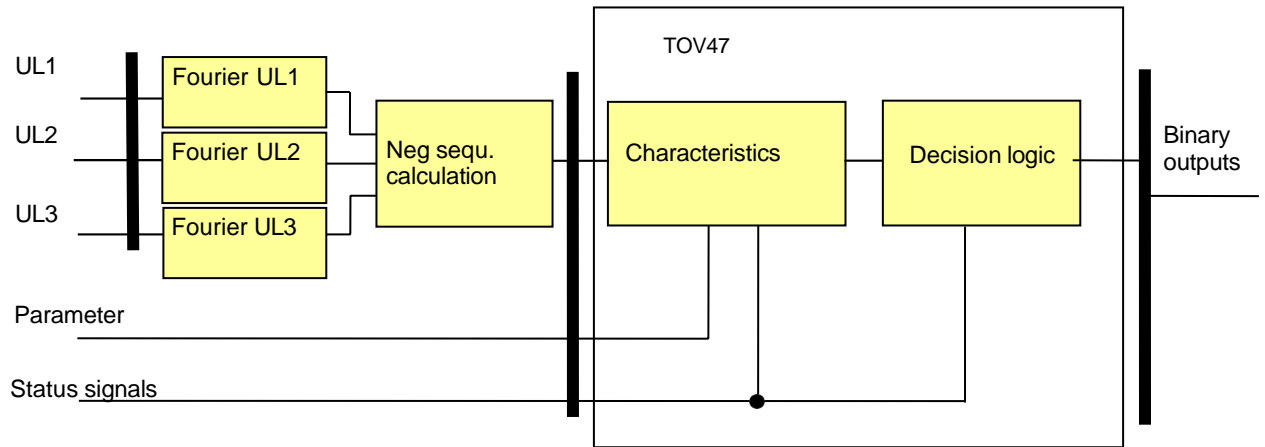

Figure 1-2 Structure of the negative sequence definite time overvoltage protection algorithm

The **inputs** are

- the RMS value of the negative sequence fundamental Fourier component, calculated using the sampled three phase voltages,
- parameters,
- status signals.

The **outputs** are

- the binary output status signals.

The **software modules** of the definite time overvoltage protection function:

Fourier calculations

These modules calculate the basic Fourier components of the phase voltages individually (not part of the TOV47 function).

Neg sequ. calculation

This module calculates the negative sequence basic Fourier component (not part of the TOV47 function).

Characteristics

This module calculates the required time delay based on the Fourier components of the negative sequence voltage component.

Decision logic

The decision logic module combines the status signals to generate the trip command of the function.

The following description explains the details of the individual components.

C

4.1.10.5. The Fourier calculation (Fourier)

These modules calculate the basic Fourier components of the phase voltages individually. They are not part of the TOV47 function; they belong to the preparatory phase.

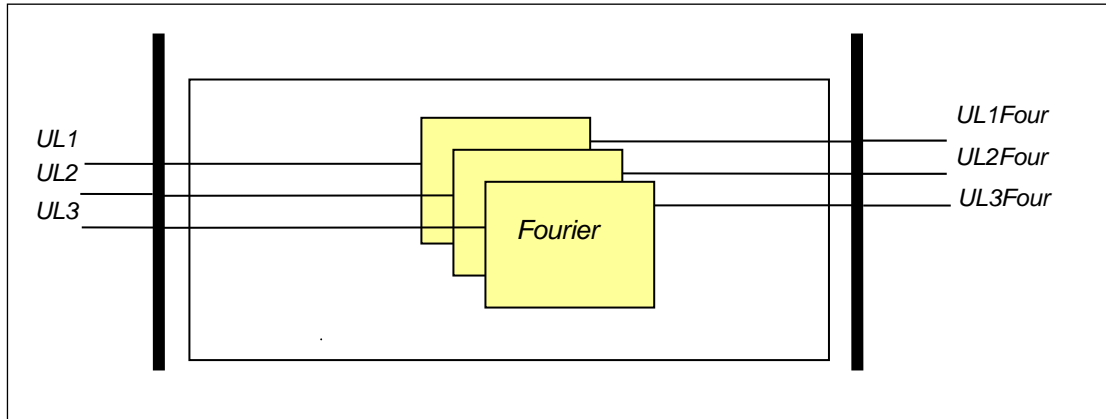

Figure 1-3 Schema of the Fourier calculation

The **inputs** are the sampled values of the three phase voltages (UL1, UL2, UL3)

The **outputs** are the RMS values of the basic Fourier components of the analyzed voltages (UL1Four, UL2Four, UL3Four).

4.1.10.6. The negative sequence component calculation (Neg sequ. Calculation)

This module calculates the negative sequent basic Fourier component. This is not part of the TOV47 function; it belongs to the preparatory phase.

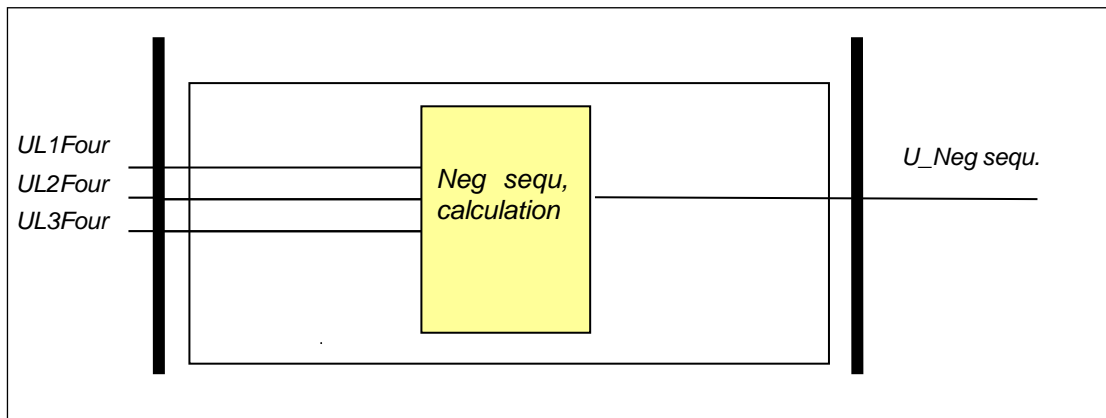

Figure 1-4 Schema of the negative sequence component calculation

The **inputs** are the RMS values of the basic Fourier components of the analyzed voltages (UL1Four, UL2Four, UL3Four).

The **output** is the RMS value of the negative sequence basic Fourier component voltage (U_Neg sequ.).

4.1.10.8. The decision logic (Decision logic)

The decision logic module combines the internal status signals, Boolean and binary parameters to generate the trip command of the function.

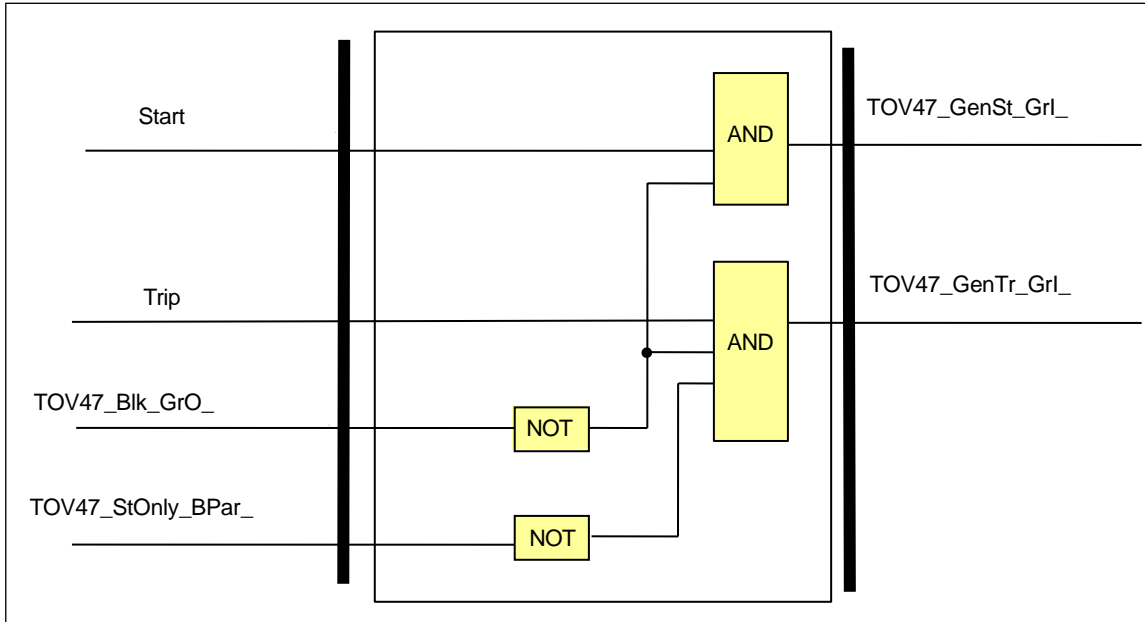

Figure 1-6 The decision logic scheme of the negative sequence definite time overvoltage protection function

Boolean parameter

Parameter name	Title	Default
Enabling start signal only:		
TOV47_StOnly_BPar_	Start Signal Only	FALSE

Table 1-4 The Boolean parameter of the negative sequence definite time overvoltage protection function

The negative sequence overvoltage protection function has a binary input signal, which serves the purpose of disabling the function. **The conditions of disabling are defined by the user, applying the graphic equation editor.**

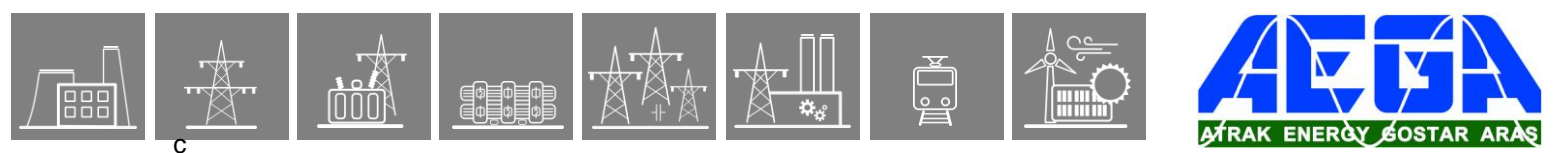

C

Binary input status signal

Binary status signal	Explanation
TOV47_Blk_GrO_	Output status of a graphic editor defined by the user to disable the negative sequence definite time overvoltage protection function.

Table 1-5 The binary input signal of the negative sequence definite time overvoltage protection function

Binary output status signals

Binary status signal	Title	Explanation
TOV47_GenSt_GrI_	General Start	General start signal
TOV47_GenTr_GrI_	General Trip	General trip command

Table 1-6 The binary output status signals of the negative sequence definite time overvoltage protection function

4.1.10.9. Technical summary

4.1.10.9.1. Technical data

Function	Value	Accuracy
Pick-up starting accuracy		< ± 0,5 %
Blocking voltage		< ± 1,5 %
Reset time		
U> → Un	60 ms	
U> → 0	50 ms	
Operate time accuracy		< ± 20 ms
Drop-off ratio		± 0.5 %
Minimum operate time	50 ms	

Table 1-7 Technical data of the negative sequence definite time overvoltage protection function

4.1.10.9.2. The parameters

The parameters are summarized in Chapter [1.7 Table 1-1](#), [Table 1-2](#), and in Chapter [1.8 Table 1-4](#).

4.1.10.9.3. The status signals

The status signals are summarized in Chapter [1.8 Table 1-5](#) and [Table 1-6](#).

4.1.10.9.4. The function block

The function block of the overvoltage protection function is shown in [Figure 1-7](#). This block shows all binary input and output status signals that are applicable in the graphic logic editor.

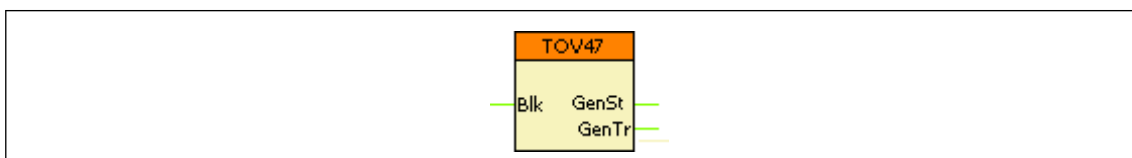
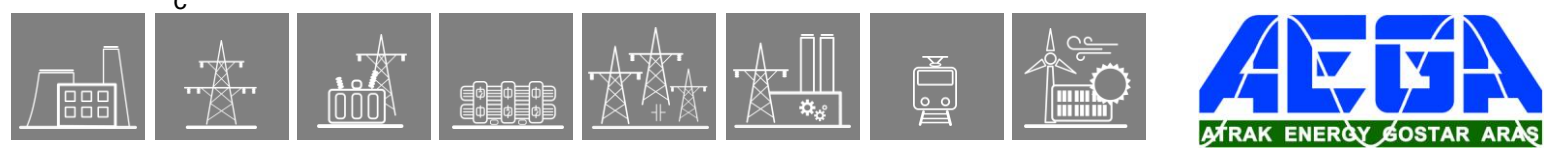

Figure 1-7 The function block of the negative sequence definite time overvoltage protection function



4.1.11. Line thermal protection function

Basically, line thermal protection measures the three sampled phase currents. RMS values are calculated and the temperature calculation is based on the highest RMS value of the phase currents.

The temperature calculation is based on the step-by-step solution of the thermal differential equation. This method yields “overtemperature”, meaning the temperature above the ambient temperature (of the environment). Accordingly, the temperature of the protected object is the sum of the calculated “overtemperature” and the ambient temperature.

The ambient temperature can be measured using e.g. a temperature probe generating electric analog signals proportional to the temperature. In the absence of such measurement, the temperature of the environment can be set using the dedicated parameter TTR49L_Amb_IPar_ (Ambient Temperature). The selection between parameter value and direct measurement is made by setting the binary parameter TTR49L_Sens_BPar_ (Temperature sensor). (Special HW input module is required.)

If the calculated temperature (calculated “overtemperature”+ambient temperature) is above the threshold values, status signals are generated:

TTR49L_Alm_IPar_ (Alarm temperature) TTR49L_Trip_IPar_ (Trip temperature)
 TTR49L_Unl_IPar_ (Unlock temperature)

For correct setting, the following values must be measured and set as parameters:

TTR49L_Inom_IPar_ (Rated load current: continuous current applied for the measurement)
 TTR49L_Max_IPar_ (Rated temperature: the steady state temperature at rated load current)
 TTR49L_Ref_IPar_ (Base Temperature: the temperature of the environment during the measurement of the rated values)
 TTR49L_pT_IPar_ (time constant: measured heating/cooling time constant of the exponential temperature function)

When energizing the protection device, the algorithm permits the definition of the starting temperature as the initial value of the calculated temperature:

TTR49L_Str_IPar_ (Startup Temp.: Initial temperature above the temperature of the environment as compared to the rated temperature above the base temperature)

The problem of metal elements (the protected line) exposed to the sun is that they are overheated as compared to the „ambient” temperature even without a heating current; furthermore, they are cooled mostly by the wind and the heat transfer coefficient is highly dependent on the effects of the wind. As the overhead lines are located in different geographical environments along the tens of kilometers of the route, the effects of the sun and the wind cannot be considered in detail. The best approximation is to measure the temperature of a piece of overhead line without current but exposed to the same environmental conditions as the protected line itself.

The application of thermal protection of the overhead line is a better solution than a simple overcurrent-based protection because thermal protection “remembers” the preceding load states of the line and the setting of the thermal protection does not need so a high security margin between the permitted current and the permitted continuous thermal current of the line. In a broad range of load states and in a broad range of ambient temperatures this

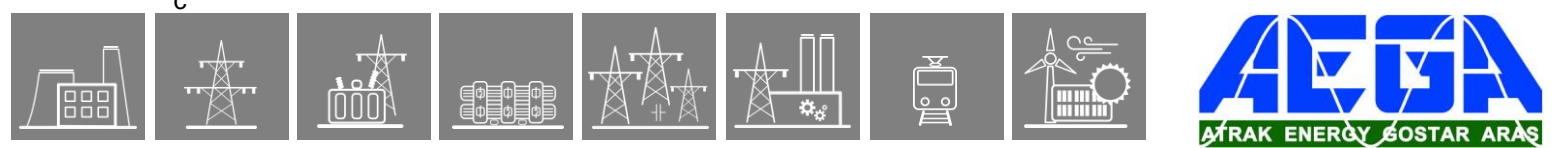

permits the better exploitation of the thermal and consequently current carrying capacity of the line.

4.1.11.1. Theory of the thermal replica calculations

4.1.11.1.1. The thermal differential equation

The theory of solving the thermal differential equation is described and explained in detail in the document ["The thermal differential equation"].

The source of the formulas below is that document. The

thermal differential equation to be solved is:

$$\frac{d\Theta}{dt} = \frac{1}{T} \left(\frac{I^2(t)R}{hA} - \Theta \right) \quad (1)$$

The definition of the heat time constant is:

$$T = \frac{cm}{hA}$$

In this differential equation:

- I(t) (RMS) heating current, the RMS value usually changes over time;
- R resistance of the line;
- c specific heat capacity of the conductor;
- m mass of the conductor;
- θ rise of the temperature above the temperature of the environment; h
- heat transfer coefficient of the surface of the conductor;
- A area of the surface of the conductor;
- t time.

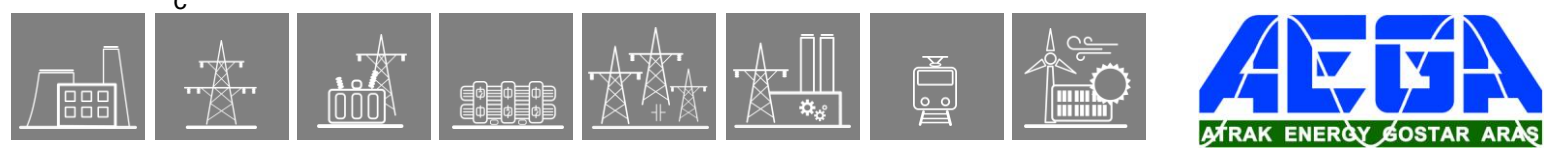

4.1.11.1.2. The temperature-time function for constant current

The solution of the thermal differential equation for constant current is the temperature as the function of time. (The mathematical derivation of this equation is described in a separate document.)

$$\Theta(t) = \frac{I^2 R}{hA} \left(1 - e^{-\frac{t}{T}} \right) + \Theta_0 e^{-\frac{t}{T}} \quad (2)$$

Remember that the calculation of the measurable temperature is as follows:

$$\text{Temperature}(t) = \Theta(t) + \text{Temp_ambient}$$

where

Temp_ambient is the ambient temperature.

In that separate document it is proven that some more easily measurable parameters can be introduced instead of the aforementioned ones. Thus, the general form of equation (2) is:

$$H(t) = \frac{\Theta(t)}{\Theta_n} = \frac{I^2}{I_n^2} \left(1 - e^{-\frac{t}{T}} \right) + \frac{\Theta_0}{\Theta_n} e^{-\frac{t}{T}} \quad (3)$$

where:

H(t) is the „thermal level” of the heated object, **this is the temperature as a percentage of the Θ_n reference temperature.** (This is a dimensionless quantity but it can also be expressed in a percentage form.)

Θ_0 is the starting temperature above the temperature of the environment

Θ_n is the reference temperature above the temperature of the environment, which can be measured in steady state, in case of a continuous I_n reference current.

I_n is the reference current (can be considered as the nominal current of the heated object). If it flows continuously, then the reference temperature can be measured in steady state.

4.1.11.1.3. Formulas for checking the thermal protection functions

Equation (3) offers a general formula to check the operation of the thermal protection using constant current.

The changes of temperature over time, (above the temperature of the environment), described by equation (3), are plotted in the diagram below. Parameter is the starting

temperature related to the reference temperature $\frac{\Theta_o}{\Theta_n}$

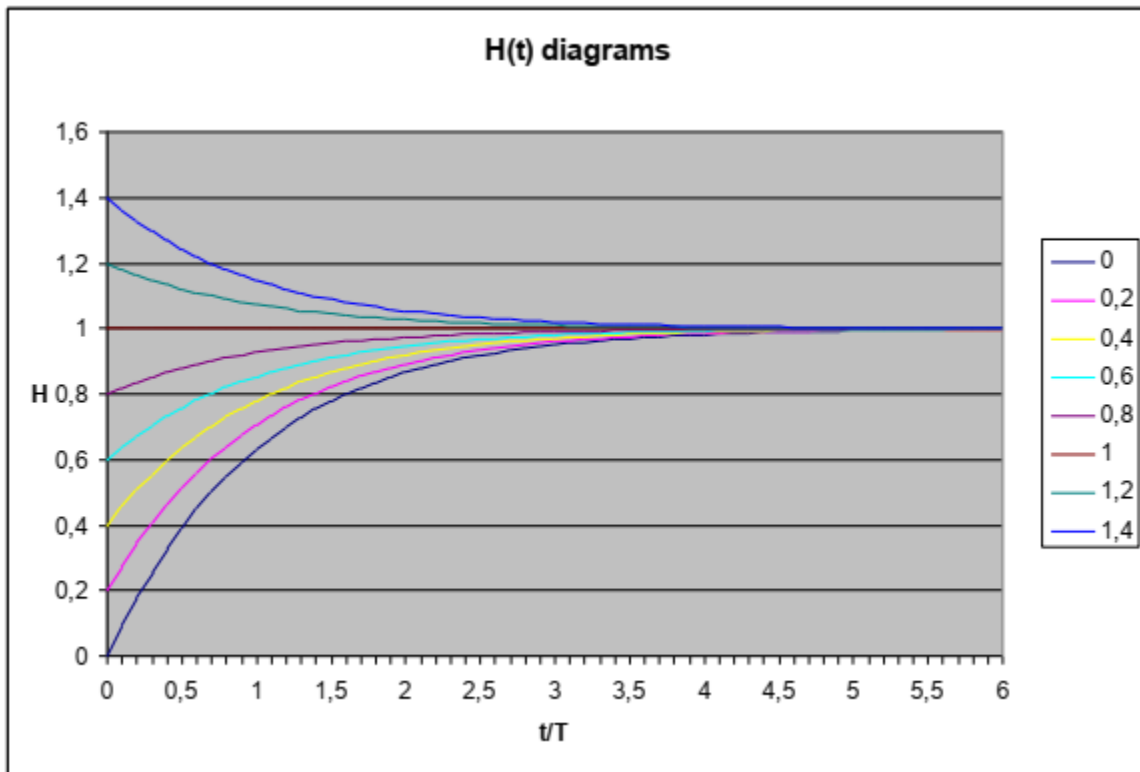

For further tests, the time needed to reach a specific temperature value can be calculated based on equation (3). The derived formula with relative quantities is:

$$\frac{t}{T} = \ln \left(\frac{\frac{\Theta_s - \Theta_o}{\Theta_n - \Theta_n}}{\frac{\Theta_s - \Theta_{set}}{\Theta_n - \Theta_n}} \right) \quad (4)$$

where:

$\Theta_s = \frac{I^2 \Theta_n}{I_n^2}$ is the steady state temperature in case of continuous I current,

Θ_{set} is the momentary temperature above the ambient temperature; the time to reach this is to be calculated,

Θ_o is the starting „overtemperature”,

Θ_n is the reference temperature above the temperature of the environment, which can be measured in steady state, in case of a continuous I_n reference current.

To be able to compare the current–time characteristics of the thermal protection with that of the inverse characteristics, formula (4) can be rearranged using currents and per unit quantities:

$$\frac{t}{T} = \ln \frac{\frac{I^2}{I_{set}^2} - \frac{I_0^2}{I_{set}^2}}{\frac{I^2}{I_{set}^2} - 1} \quad (5)$$

where:

I_0 is the continuous current that results Θ_0 steady state “overtemperature” at the beginning of the calculation,

I is the current that is applied to reach the steady state Θ_S “overtemperature”,

$$(\Theta_S = \frac{I^2 \Theta_n}{I_n^2}).$$

I_{set} would be the setting current of the equivalent „overcurrent” function.

The plots according to equation (5) can be seen below. They show how much time is left to reach the „trip temperature” in case of a continuous I (RMS) current. The parameter is the continuous I_0 current related to the I_n rated current, which generates the steady state starting temperature. The topmost curve is the „cold curve”.

The plots below clearly show that the thermal replica method “remembers” the starting temperature. If the starting temperature (I_0 pre-faulty steady state current) is increased, the time to trip at a fault current $I/I_{set} > 1$ automatically decreases.

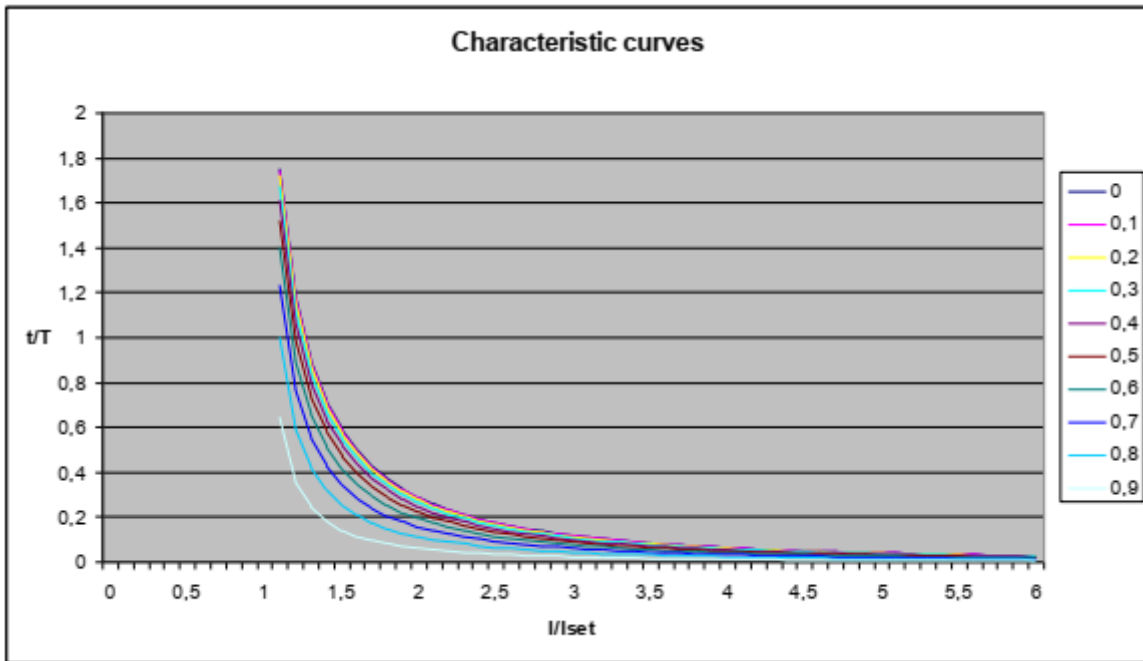



4.1.11.1.4. Numerical solution of the thermal differential equation

The formulas (2-5) above refer to a constant current and can be used to test the thermal protection. In reality, the RMS value of the current changes over time; consequently, differential equation (1) must be solved using a numerical method. The separate document explains the steps to obtain the calculation formula:

$$H_k = \frac{\Theta_k}{\Theta_n} = \left(1 - \frac{\Delta t}{T}\right) \frac{\Theta_{k-1}}{\Theta_n} + \frac{\Delta t}{T} \frac{I^2}{I_n^2} \quad (6)$$

where:

- Θ_k is the temperature (above the temperature of the environment) at the k-th calculation step;
- Θ_{k-1} is the temperature (above the temperature of the environment) one calculation step before.

(The line thermal protection is calculating the temperature based on the formula (6) above, the user of the thermal protection does not need to apply it.)

4.1.11.2. Structure of the line thermal protection

Fig.1-1 shows the structure of the line thermal protection (TTR49L) algorithm.

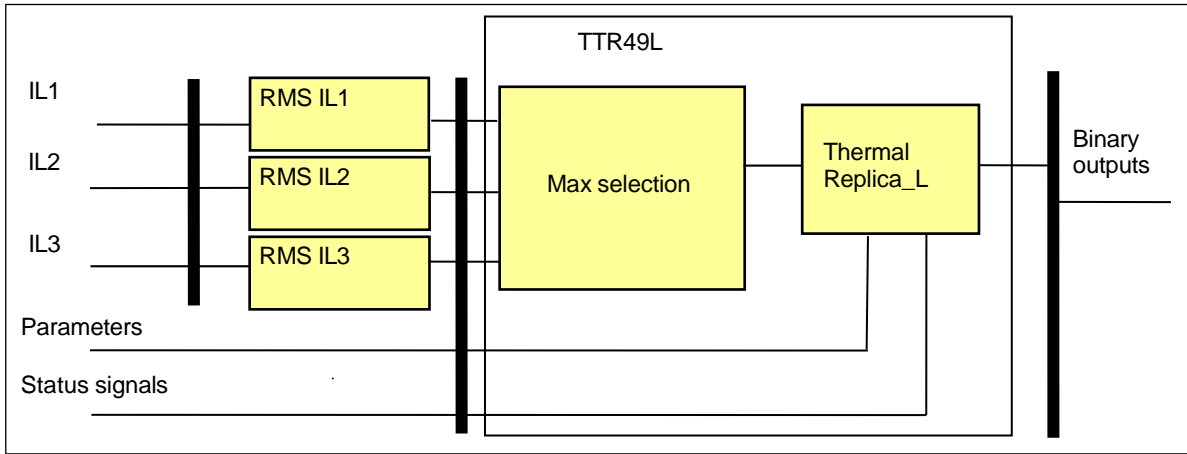

Figure 1-1 Structure of the line thermal protection algorithm

The **inputs** are the RMS values of three primary phase currents, parameters, status signals.

The **outputs** are the binary output status signals.

The **software modules** of the line thermal protection function:

RMS calculations

These modules calculate the RMS values of the phase currents individually. The sampling frequency of the calculations is 1 kHz; therefore, theoretically, the frequency components below 500Hz are considered correctly in the RMS values. This module is not part of the thermal function; it belongs to the preparatory phase.

Max selection

This module selects the maximal value of the RMS phase currents.

Thermal replica

This module solves the first order thermal differential equation using a simple step-by-step method and compares the calculated temperature to the values set by parameters.

The following description explains the details of the individual components.

4.1.11.3. RMS calculation (RMS)

These modules calculate the true RMS values of the phase currents individually. The sampling frequency of the calculations is 1 kHz; therefore, theoretically, the frequency components below 500Hz are considered correctly in the RMS values. This module is not part of the thermal function; it belongs to the preparatory phase.

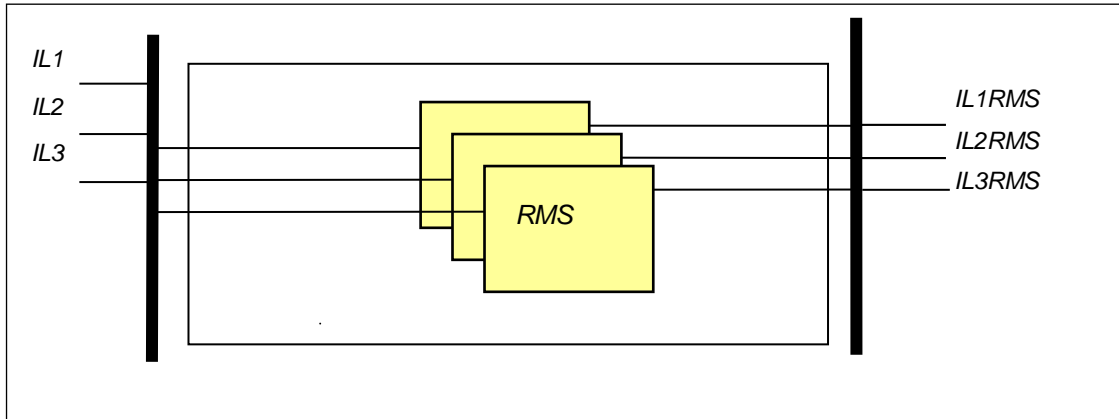

Figure 1-2 Principal scheme of the current RMS calculation

The **inputs** are the sampled values of the three phase currents (IL1, IL2, IL3)

The **outputs** are the RMS values of the analyzed currents (IL1RMS, IL2RMS, IL3RMS).

4.1.11.4. The maximum selection (Max selection)

This module selects the maximum of the three RMS values.

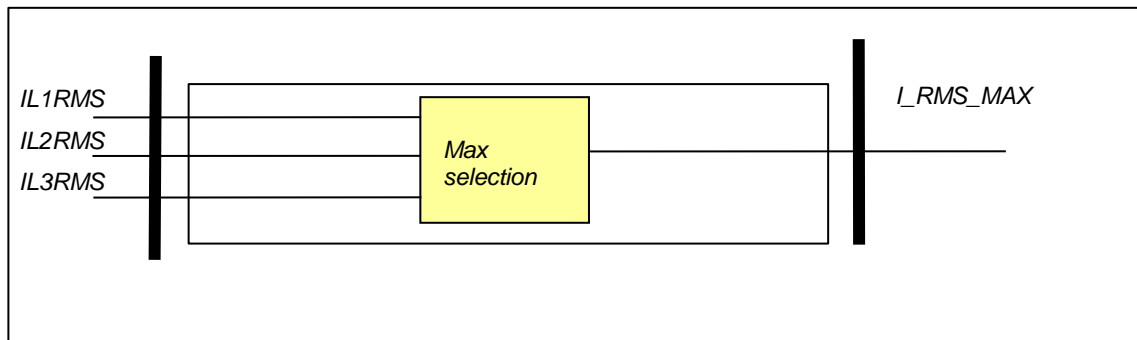
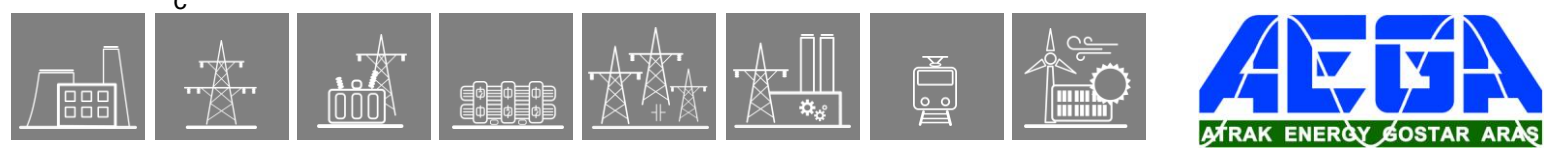

Figure 1-3 Principal scheme of the maximum selection

The **inputs** are the RMS values of the analyzed currents (IL1RMS, IL2RMS, IL3RMS). The

output is the selected maximum of the three RMS values.



4.1.11.5. The temperature calculation and decision (Thermal replic)

This module solves the first order thermal differential equation using a simple step-by-step method and compares the calculated temperature to the values set by parameters.

The **inputs** are

- The selected maximum of the three RMS values of the phase currents,
- The value proportional to the ambient temperature (this signal is optional, defined at parameter setting),
- Binary input status signals,

Parameters.

The **outputs** are the status signals. These indicate the generated trip command if the temperature is above the preset current value.

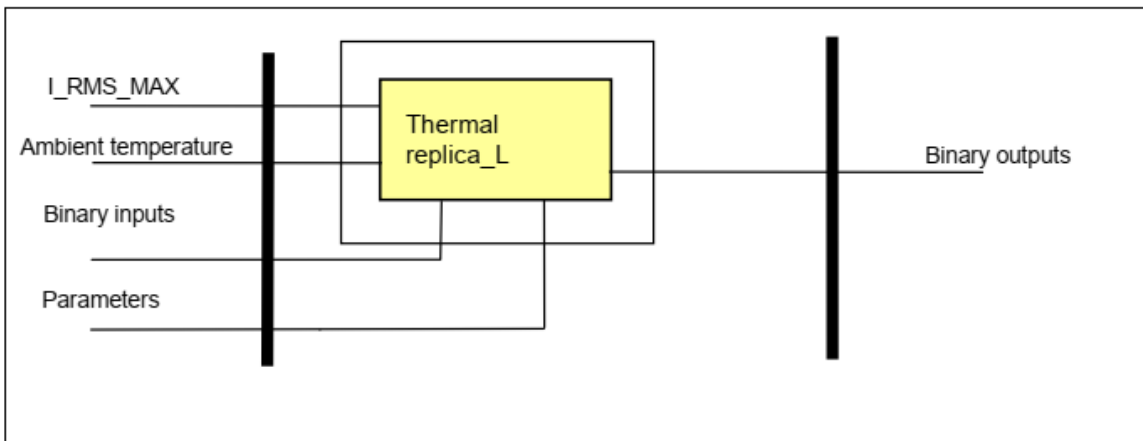
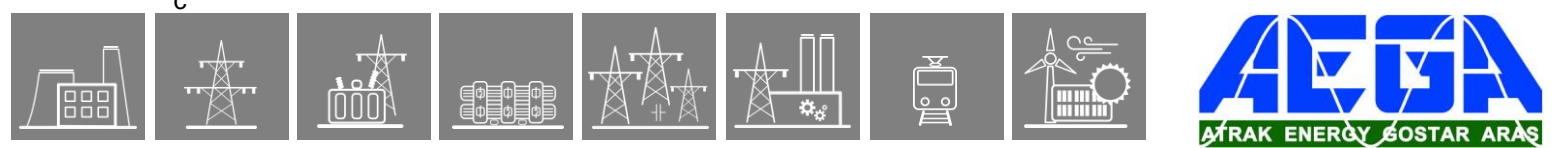

Figure 1-4 Principal scheme of the thermal replica calculation



Enumerated parameter

Parameter name	Title	Selection range	Default
Parameter for mode of operation			
TTR49L_Oper_EPar_	Operation	Off, Pulsed, Locked	Pulsed

Table 1-1 The enumerated parameters of the line thermal protection function

The meaning of the enumerated values is as follows:

- Off The function is switched off; no output status signals are generated;
- Pulsed The function generates a trip pulse if the calculated temperature exceeds the trip value
- Locked The function generates a trip signal if the calculated temperature exceeds the trip value. It resets only if the temperature cools below the “Unlock temperature”.

Integer parameters

Parameter name	Title	Unit	Min	Max	Step	Default
Alarm Temperature						
TTR49L_Alm_IPar_	Alarm Temperature	deg	60	200	1	80
Trip Temperature						
TTR49L_Trip_IPar_	Trip Temperature	deg	60	200	1	100
Rated Temperature						
TTR49L_Max_IPar_	Rated Temperature	deg	60	200	1	100
Base Temperature						
TTR49L_Ref_IPar_	Base Temperature	deg	0	40	1	25
Unlock Temperature						
TTR49L_Unl_IPar_	Unlock Temperature	deg	20	200	1	60
Ambient Temperature						
TTR49L_Amb_IPar_	Ambient Temperature	deg	0	40	1	25
Startup Term.						
TTR49L_Str_IPar	Startup Term	%	0	60	1	0
Rated Load Current						
TTR49L_Inom_IPar_	Rated Load Current	%	20	150	1	100
Time constant						
TTR49L_pT_IPar_	Time Constant	min	1	999	1	10

Table 1-2 The integer parameters of the line thermal protection function

Boolean parameter

Boolean parameter	Signal title	Selection range	Default
Parameter for ambient temperature sensor application (Special HW input module is required)			
TTR49L_Sens_BPar_	Temperature Sensor	No, Yes	No

Table 1-3 The Boolean parameter of the line thermal protection function

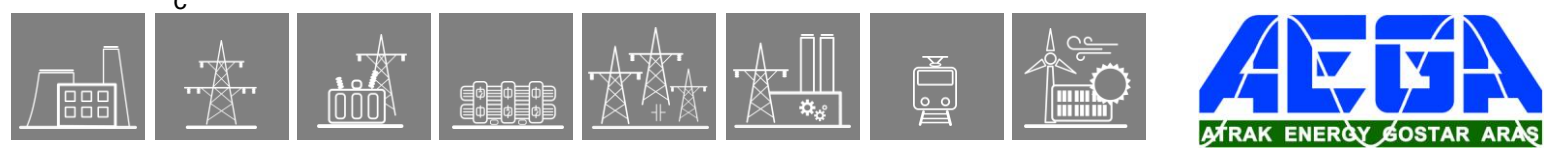

The **binary output status signals** of the line thermal protection function are shown in [Table 1-4](#).

Binary output signals	Signal title	Explanation
TTR49L_Alm_Grl_	Alarm	Alarm signal of the line thermal protection function
TTR49L_GenTr_Grl_	General Trip	General trip signal of the line thermal protection function
TTR49L_Lock_Grl_	Reclose locked	Line reclose blocking signal of the line thermal protection function

Table 1-4 The binary output status signals of the line thermal protection function

Binary input status signals

The line thermal protection function has two binary input status signals. One of them serves to disable the function; the other one resets the accumulated heat. Resetting serves test purposes only, if the heating calculation needs to start at a clearly defined temperature. Using this signal, the testing engineer need not wait until the cooling reaches the required starting temperature of the subsequent heating test.

Both binary input status signals are defined by the user, applying the graphic equation editor.

The binary input status signals of the line thermal protection function are shown in [Table 1-5](#).

Binary input status signals	Title	Explanation
TTR49L_BlK_GrO_	Block	Output status of a graphic equation defined by the user to disable the line thermal protection function.
TTR49L_Reset_GrO_	Reset	Output status of a graphic equation defined by the user to reset the accumulated heat and set the temperature to the defined value for the subsequent heating test procedure.

Table 1-5 The binary input signals of the line thermal protection function

On-line measured value

On-line measured value	Explanation
TTR49L_Temp_OLM_	The calculated temperature.

Table 1-6 The on-line measured value of the line thermal protection function

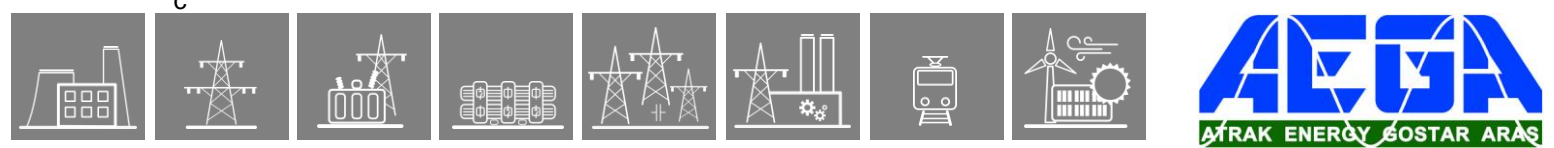

4.1.11.6. Technical summary

4.1.11.6.1. Technical data

Function	Accuracy
Operate time at $I > 1.2 \cdot I_{trip}$	$< 3\%$ or $< + 20\text{ ms}$

Table 1-7 Technical data of the line thermal protection function

4.1.11.6.2. The parameters

The parameters are summarized in Chapter [1.5](#).

4.1.11.6.3. The binary input status signals

The line thermal replica protection function has a binary input signal that serves the purpose of disabling the function. **The conditions of disabling are defined by the user, applying the graphic equation editor.**

The other binary input signal serves the purpose of resetting the stored temperature (supports testing the function). **The conditions of resetting the temperature are defined by the user, applying the graphic equation editor.**

Binary input signal	Explanation
TTR49L_BlK_GrO_	Output status of a graphic equation defined by the user to disable the line thermal protection function.
TTR49L_Reset_GrO_	Output status of a graphic equation defined by the user to reset the accumulated heat and set the temperature to the defined value for the subsequent heating test procedure.

Table 1-8 The binary input signal of the line thermal protection function

4.1.11.6.4. Binary output status signals

The **binary output status signals** of the restricted earth-fault protection function are listed in [Table 1-9](#).

Binary output signals	Signal title	Explanation
TTR49L_Alm_GrI_	Alarm	Alarm signal of the line thermal protection function
TTR49L_GenTr_GrI_	General Trip	General trip signal of the line thermal protection function
TTR49L_Lock_GrI_	Reclose locked	Line reclose blocking signal of the line thermal protection function

Table 1-9 The binary output status signals of the line thermal protection function

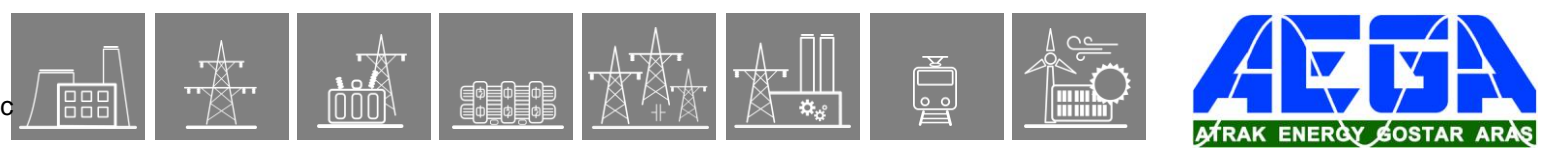

4.1.11.6.5. The function block

The function block of the line thermal_protection function is shown in [Figure 1-5](#). This block shows all binary input and output status signals that are applicable in the graphic equation editor.

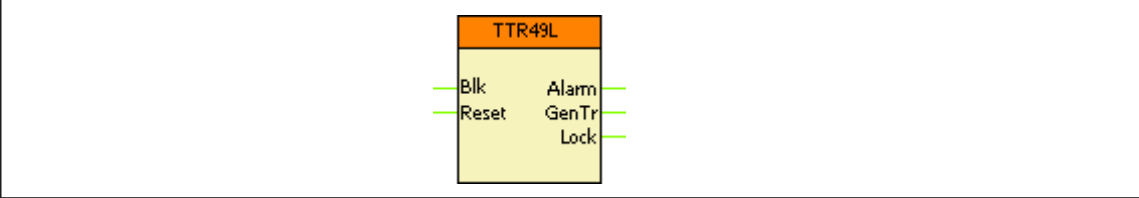
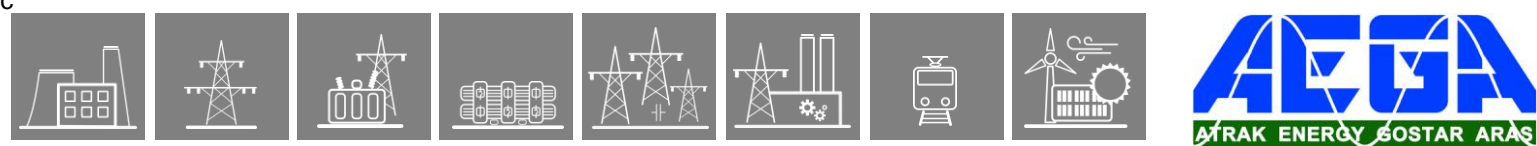

Figure 1-5 The function block of the line thermal protection function



4.1.12. Three-phase instantaneous Overcurrent Protection

4.1.12.1. Application

The instantaneous overcurrent protection function operates according to instantaneous characteristics, using the three sampled phase currents. The setting value is a parameter, and it can be doubled by graphic programming of the dedicated input binary signal.

The basic calculation can be based on peak value selection or on Fourier basic harmonic calculation, according to the parameter setting. When Fourier calculation is selected then the accuracy of the operation is high, the operation time however is above one period of the network frequency. If the operation is based on peak values, then fast sub-cycle operation can be expected, but the transient overreach can be high.

4.1.12.1.1. Operating Characteristics

$$t(I) = t_{OP} \text{ when } I > I_S$$

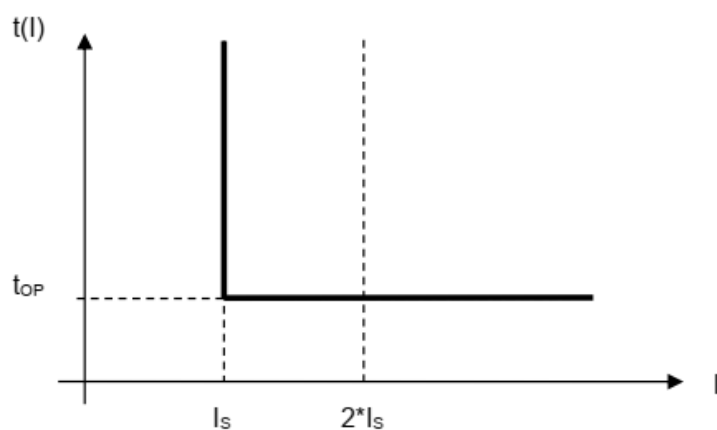

Figure 1-1 Overcurrent independent time characteristic

where:

- t_{OP} (sec.) theoretical operating time if $I > I_{GS}$ (without additional time delay),
- I measured value of the characteristic quantity, peak values or Fourier base harmonic of the phase currents,
- I_S setting value of the characteristic quantity (*Start current*)

4.1.12.1.2. Structure of the Protection Algorithm

Figure 1-2 shows the structure of the instantaneous overcurrent protection (IOC50) algorithm.

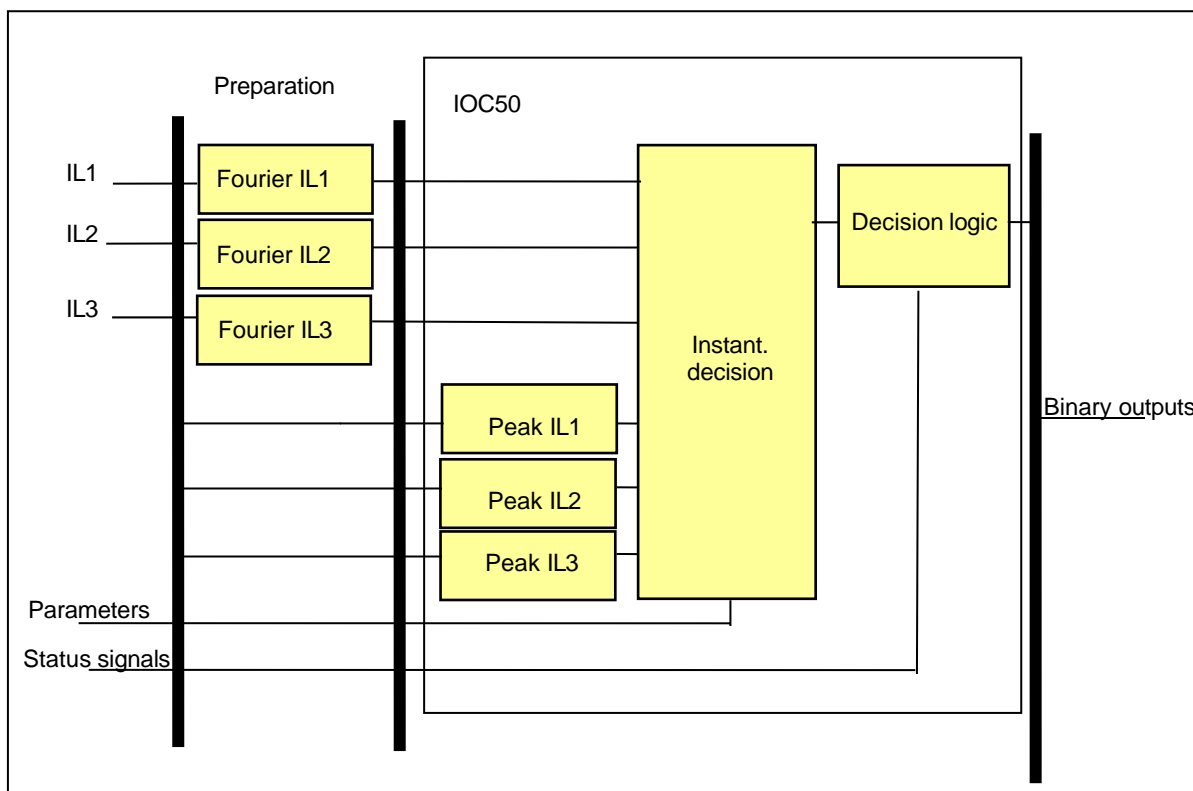

Figure 1-2 Structure of the instantaneous overcurrent protection algorithm

The **inputs** are

- the sampled values of three phase currents,
- the RMS values of the fundamental Fourier component of three phase currents,
- parameters,
- status signals.

The **outputs** are

- the binary output status signals.

The **software modules** of the three-phase instantaneous overcurrent protection function are:

Fourier calculations

These modules calculate the RMS values of the fundamental Fourier component of three phase currents individually (not part of the IOC50 function).

Peak selection

These modules select the peak values of the phase currents individually.

Instantaneous decision

This module compares the peak value or the Fourier basic harmonic components of the phase currents with the setting value.

Decision logic

The decision logic modules generate the trip command of the function.

4.1.12.1.3. The Fourier Calculation (Fourier)

The following description explains the details of the individual components.

These modules calculate the RMS values of the fundamental Fourier component of the three phase currents individually. They are not part of the IOC50 function; they belong to the preparatory phase.

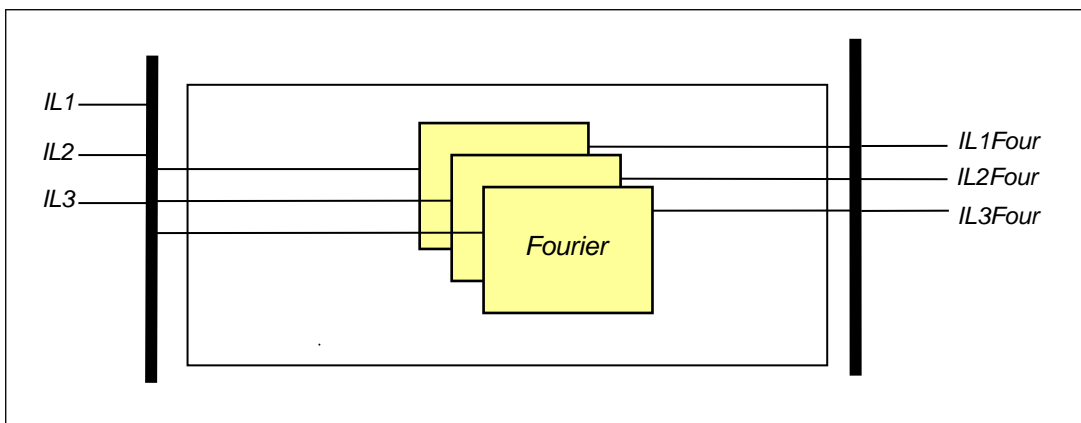

Figure 1-3 Principal scheme of the Fourier calculation

The **inputs** are the sampled values of the three phase currents (IL1, IL2, IL3).

The **outputs** are the RMS values of the fundamental Fourier component of three phase currents (IL1Four, IL2Four, IL3Four).

4.1.12.1.4. The Peak Selection (Peak selection)

These modules select the peak values of the phase currents individually.

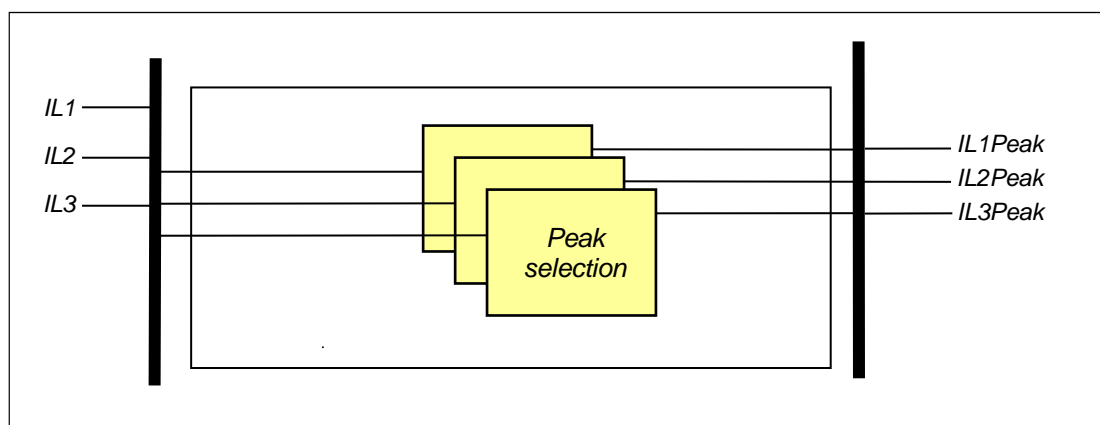
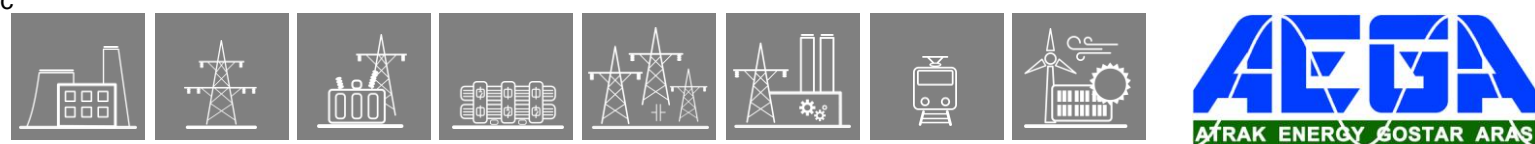

Figure 1-4 Principal scheme of the peak selection

The **inputs** are the sampled values of the three phase currents (IL1, IL2, IL3).

The **outputs** are the peak values of the analyzed currents (IL1Peak, IL2 Peak, IL3 Peak).



4.1.12.1.5. The Instantaneous Decision (Instantaneous decision)

This module generates trip commands for the phases without additional time delay based on the Fourier components of the phase currents or based on the peak values, if the detected values are above the current setting value.

The **inputs** are the RMS values of the fundamental Fourier component of three phase currents (IL1Four, IL2Four, IL3Four), the peak values (IL1Peak, IL2 Peak, IL3 Peak), parameters and status signals.

The **outputs** are the status signals of the three phases individually. These indicate the generated trip commands if the currents are above the current setting value.

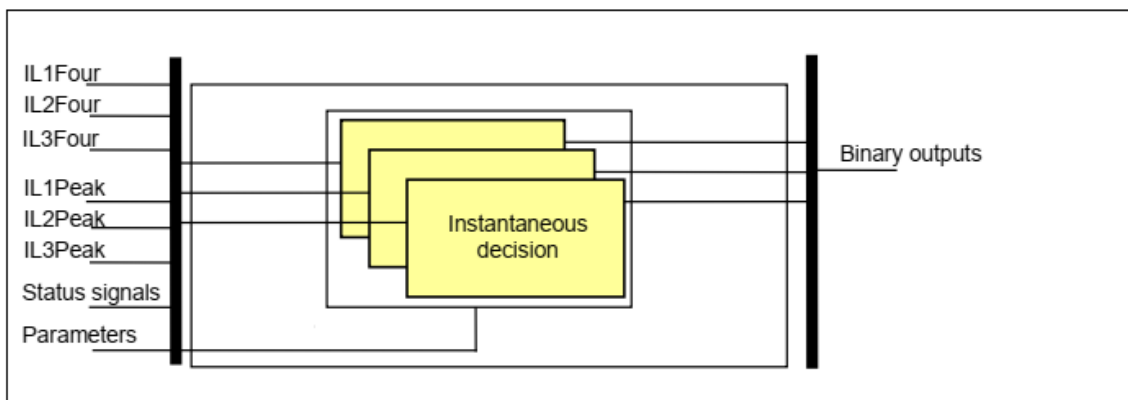

Figure 1-5 Principal scheme of the instantaneous characteristic calculation

4.1.12.1.6. The Decision Logic (Decision logic)

The decision logic module combines the status signals to generate the general trip command of the function.

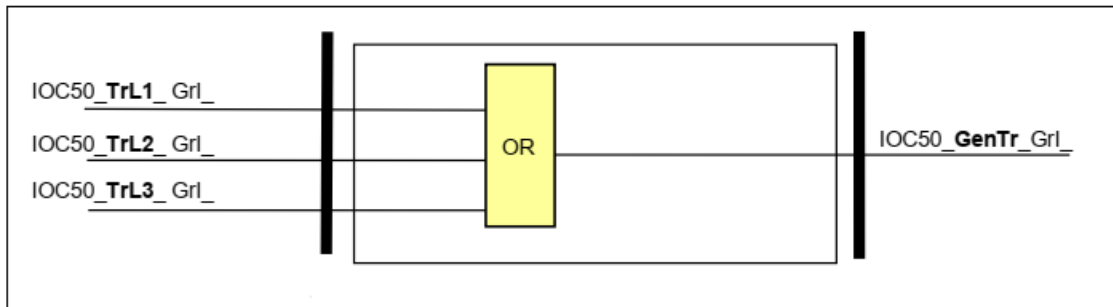

Figure 1-6 The logic scheme of the instantaneous overcurrent protection function

Table 1-5 The binary input status signals of the decision logic

BINARY INPUT SIGNAL	SIGNAL TITLE	EXPLANATION
IOC50_TrL1_Grl_	Trip L1	Trip command of the function in phase L1
IOC50_TrL2_Grl_	Trip L2	Trip command of the function in phase L2
IOC50_TrL3_Grl_	Trip L3	Trip command of the function in phase L3

Table 1-6 The binary output status signal of the decision logic

BINARY OUTPUT SIGNAL	SIGNAL TITLE	EXPLANATION
IOC50_GenTr_Grl_	General Trip	General trip command of the function

4.1.12.2. 3-Phase Instantaneous OC Function Overview

The graphic appearance of the 3-phase instantaneous overcurrent protection function block is shown in Figure 2-1. This block shows all binary input and output status signals that are applicable in the graphic equation editor.

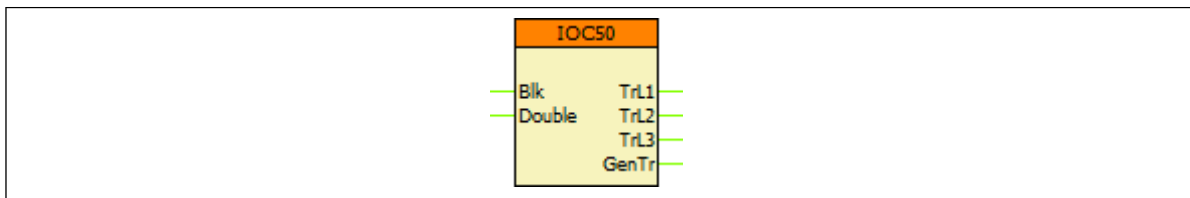

Figure 2-1 The function block of the 3-phase instantaneous overcurrent protection

4.1.12.2.1. Settings

4.1.12.2.1.1. Parameters

The available parameters are listed below in order of their appearance in the *parameters* menu. If the setting range of a parameter should be extended, contact Protecta Support.

Table 2-1 Parameters of the 3-phase instantaneous overcurrent protection function

TITLE	DIM	RANGE	STEP	DEFAULT	EXPLANATION
Operation	-	Off, Peak value, Fundamental value	-	Off	Parameter for enabling the function and selection type.
Start Current	%	20 – 3000	1	200	Start setting of the function. If the current exceeds this value, the function picks up and trips after the minimum operation time of the relay (t_{OP}).

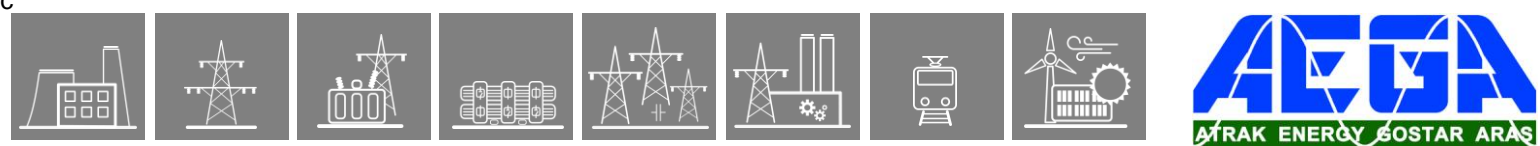

4.1.12.2.2. Function I/O

This section briefly describes the analogue and digital inputs and outputs of the function block.

4.1.12.2.2.1. Analogue inputs

The analogue inputs are the RMS values of the fundamental Fourier component of the three phase currents.

4.1.12.2.2.2. Binary input signals (graphed output statuses)

The conditions of the binary inputs are defined by the user, applying the graphic equation editor (*Logic Editor*). Parts written in **bold** are seen on the left side of the function block in the Logic editor.

Table 2-2 The binary input signals of the 3ph IOC function

BINARY INPUT SIGNAL	SIGNAL TITLE	EXPLANATION
IOC50_ Blk _GrO_	Block	Input for disabling the function
IOC50_ Double _GrO_	Double	Input used to double the value of the parameter "Start Current".

4.1.12.2.2.3. Binary output signals (graphed input statuses)

These signals can be used in EuroCAP to assign to LED, user LCD object etc. Parts written in **bold** are seen on the right side of the function block in the *Logic Editor*.

Table 2-3 The binary output signals of the 3ph IOC function

BINARY OUTPUT SIGNAL	SIGNAL TITLE	EXPLANATION
IOC50_ TrL1 _GrI_	Trip L1	Trip command of the function in phase L1
IOC50_ TrL2 _GrI_	Trip L2	Trip command of the function in phase L2
IOC50_ TrL3 _GrI_	Trip L3	Trip command of the function in phase L3
IOC50_ GenTr _GrI_	General Trip	Trip command of the function in at least one of the three phases

4.1.12.2.2.4. Online data

The following values are visible in the *online data* page.

Table 2-4 Online data of the 3ph IOC function

SIGNAL TITLE	DIMENSION	EXPLANATION
Trip L1	-	Trip command of the function in phase L1
Trip L2	-	Trip command of the function in phase L2
Trip L3	-	Trip command of the function in phase L3
General Trip	-	Trip command of the function in at least one of the three phases

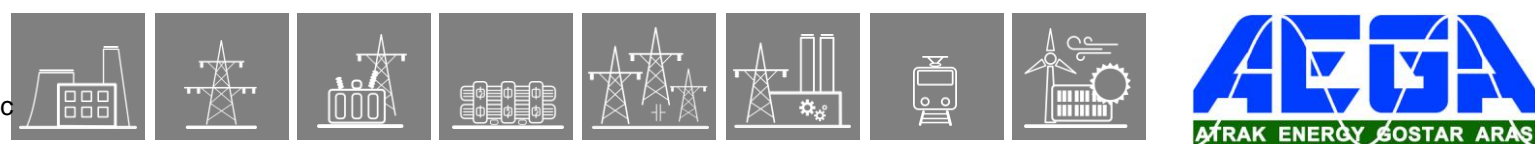

4.1.12.2.2.5. Events

The following events are generated in the event list, as well as sent to the SCADA according to the configuration.

Table 2-5 Generatable events of the 3ph IOC function

EVENT	VALUE	EXPLANATION
Trip L1	off, on	Trip command of the function in phase L1
Trip L2	off, on	Trip command of the function in phase L2
Trip L3	off, on	Trip command of the function in phase L3
General Trip	off, on	Trip command of the function in at least one of the three phases

4.1.12.2.3. Technical Data

Table 2-6 Technical data of the 3-phase IOC protection function

FUNCTION	VALUE	ACCURACY
<i>Using peak value calculation</i>		
Operating characteristic	Instantaneous	< 6%
Reset ratio	0.85	
Operate time at 2*Is	< 15 ms	
Reset time*	< 40 ms	
Transient overreach	90%	
<i>Using Fourier fundamental harmonic calculation</i>		
Operating characteristic	Instantaneous	< 2%
Reset ratio	0.85	
Operate time at 2*Is	< 25 ms	
Reset time*	< 60 ms	
Transient overreach	15%	

* Measured with signal contacts

4.1.12.2.4. Notes for Testing

Normally in the EuroProt+ devices the trip contacts are assigned to the Trip Logic function block, and not to the protection function blocks. Because of this, the testing personnel must make sure that the Trip Logic is switched on ('Operation' parameter is set to other than 'Off') before starting the tests, otherwise there will be no physical trip on the relay.

Being an instantaneous function, its connection to the Trip Logic function is done in the Fast Equations (by default) and not in the Logic Editor (usually, there are comments inserted in the Logic Editor if such connections exist). This can be checked in EuroCAP.

The analogue sources can be changed by the user (i.e. if there are multiple CT modules in a device, it might be possible to assign the measurements of either CT module to the function's inputs). This can be checked in the function block properties in EuroCAP.

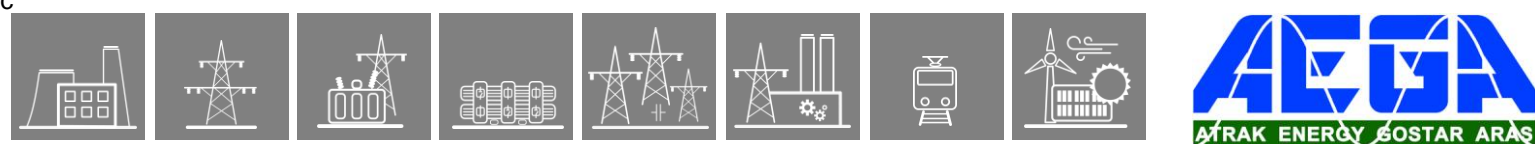

4.1.13. Residual Instantaneous Overcurrent Protection

4.1.13.1. Application

The residual instantaneous overcurrent protection function operates according to instantaneous characteristics, using the residual current ($I_N=3I_0$). The setting value is a parameter, and it can be doubled by a binary input signal defined by the user, applying the graphic programming.

The basic calculation can be based on peak value selection or on the RMS values of the fundamental Fourier component of the residual current, according to the parameter setting. When Fourier calculation is selected then the accuracy of the operation is high, the operation time, however, is above one period of the network frequency. If the operation is based on peak values, then fast sub-cycle operation can be expected, but the transient overreach can be high.

4.1.13.1.1. Operating Characteristics

$$t(I) = t_{OP} \text{ when } I > I_s$$

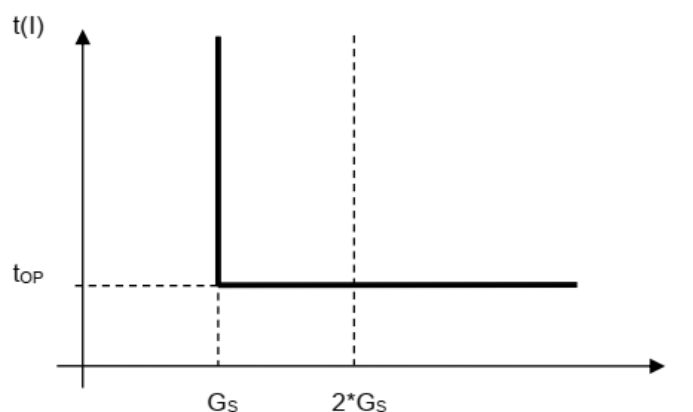

Figure 1-1 Overcurrent independent time characteristic

where:

- t_{OP} (sec.) theoretical operating time if $G > G_s$ (without additional time delay),
- G measured value of the characteristic quantity, peak values or Fourier base harmonic of the phase currents,
- G_s setting value of the characteristic quantity (*Start current*)

4.1.13.1.3. The Fourier Calculation (Fourier)

This module calculates the basic Fourier current components of the residual current. It is not part of the residual instantaneous overcurrent protection function; it belongs to the preparatory phase.

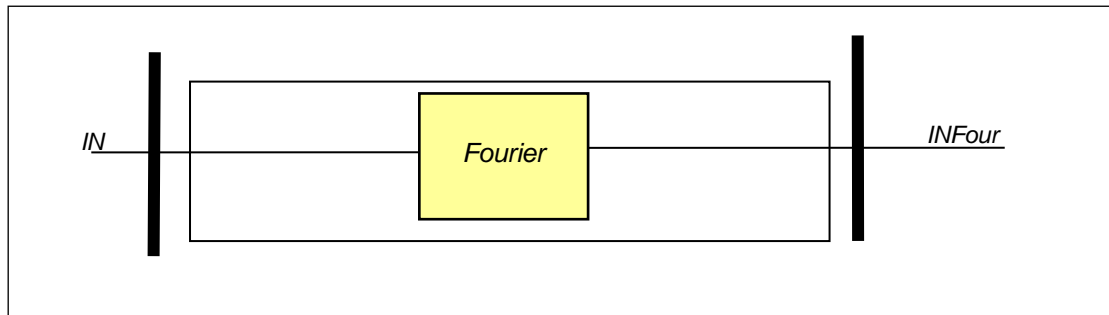

Figure 1-3 Principal scheme of the Fourier calculation

The **inputs** are the sampled values of the residual current (IN).

The **output** is the RMS value of the fundamental Fourier component of the residual current (INFour).

4.1.13.1.4. The Peak Selection (Peak selection)

This module selects the peak values of the residual current.

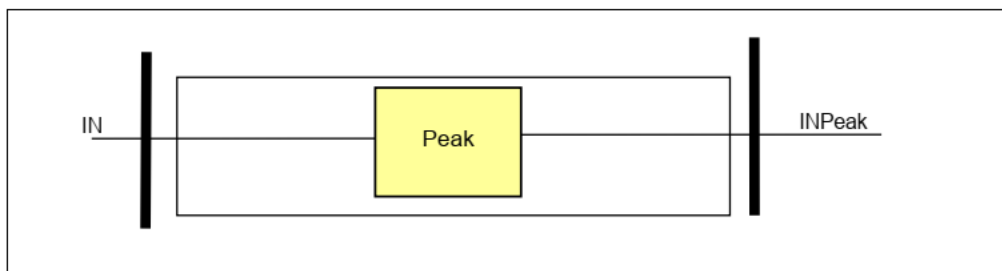
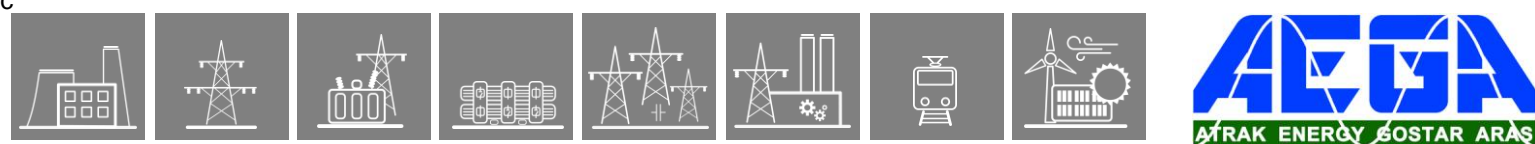

Figure 1-4 Principal scheme of the peak selection

The **inputs** are the sampled values of the residual current (IN).

The **outputs** are the peak values of the analyzed current (INPeak).



4.1.13.1.5. The Instantaneous Decision (Instantaneous decision)

This module generates an internal trip command without additional time delay based on the Fourier components of the residual current, or based on the peak values if the detected values are above the current setting value.

The **inputs** are the basic Fourier components of the residual current (INFour), the peak values (INPeak), parameters and status signals.

The **outputs** are the status signals. These indicate the generated internal trip command if the current is above the current setting value.

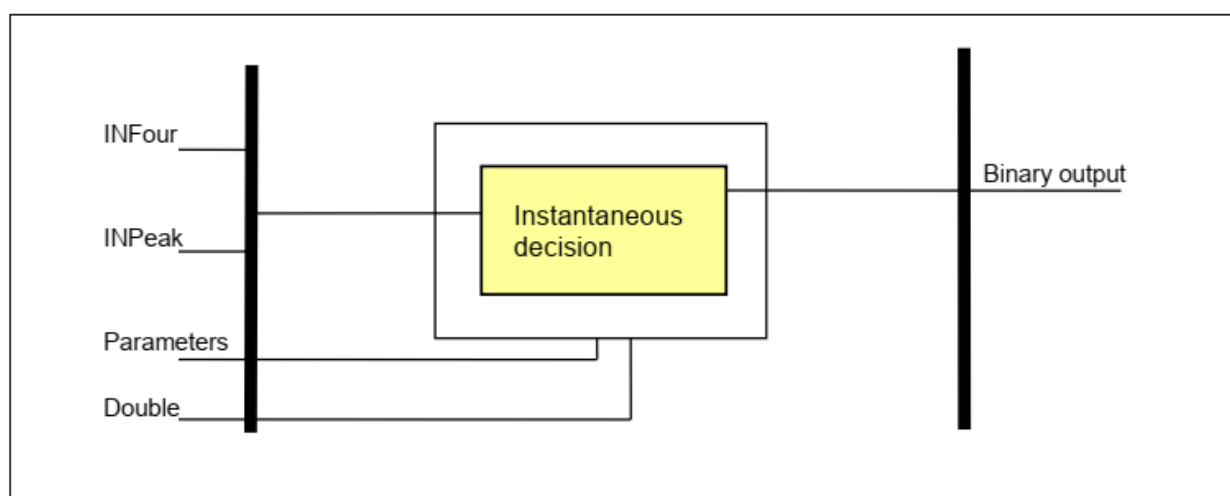
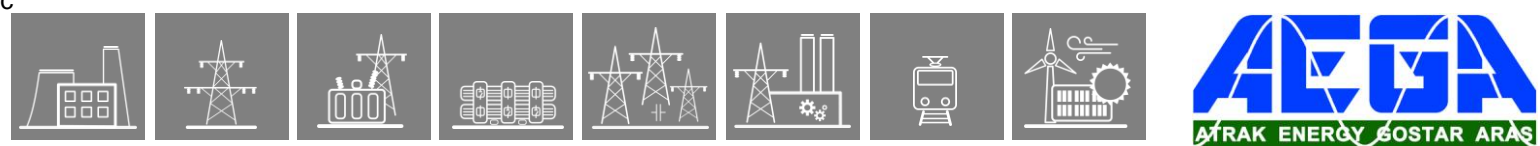

Figure 1-5 Principal scheme of the residual instantaneous characteristic calculation



Enumerated parameters

Table 1-1 The enumerated parameters of the residual IOC protection function

TITLE	DIM	RANGE	STEP	DEFAULT	EXPLANATION
Operation	-	Off, Peak value, Fundamental value	-	Off	Parameter for enabling the function and selection type.

Integer parameters

Table 1-2 The integer parameters of the residual IOC protection function

TITLE	DIM	RANGE	STEP	DEFAULT	EXPLANATION
Start Current	%	20 – 3000*	1	200	Setting value of the function.

Binary status signals

The decision block of the residual instantaneous overcurrent protection function has a binary input signal, which serves the purpose of doubling the setting value of the function. **The conditions are defined by the user, applying the graphic equation editor.**

Table 1-3 The binary input signals for the decision block of the residual IOC protection function

BINARY STATUS SIGNAL	SIGNAL TITLE	EXPLANATION
IOC50N_Double_GrO_	Double	Input used to double the value of the parameter "Start Current".

The **binary output status signal** of the residual instantaneous overcurrent protection function is shown in Table 1-4.

Table 1-4 The binary output status signal of the residual IOC protection function

BINARY OUTPUT SIGNAL	SIGNAL TITLE	EXPLANATION
IOC50N_TrN_	Trip N _i	Internal trip command of the function

4.1.13.2. Residual Instantaneous OC Function Overview

The graphic appearance of the residual instantaneous overcurrent protection function block is shown in [Figure 2-1](#). This block shows all binary input and output status signals that are applicable in the graphic equation editor.

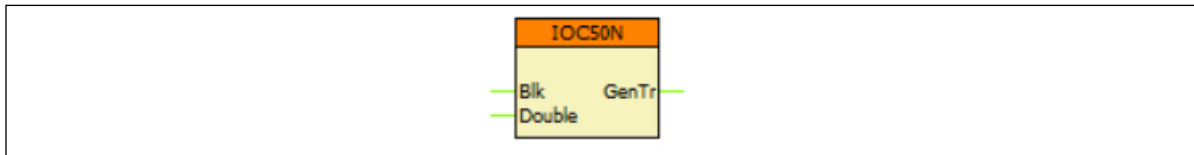

Figure 2-1 The function block of the residual instantaneous overcurrent protection

4.1.13.2.1. Settings

4.1.13.2.1.1. Parameters

The available parameters are listed below in order of their appearance in the *parameters* menu. If the setting range of a parameter should be extended, contact Protecta Support.

Table 2-1 Parameters of the residual instantaneous overcurrent protection function

TITLE	DIM	RANGE	STEP	DEFAULT	EXPLANATION
Operation	-	Off, Peak value, Fundamental value	-	Off	Parameter for enabling the function and selection type.
Start Current	%	10 – 1000*	1	200	Start value of the function, if the current exceeds this value, the function picks up and trips after the minimum operation time of the relay (t_{OP}).

*extendable to 3000 when using CT+/5151 module

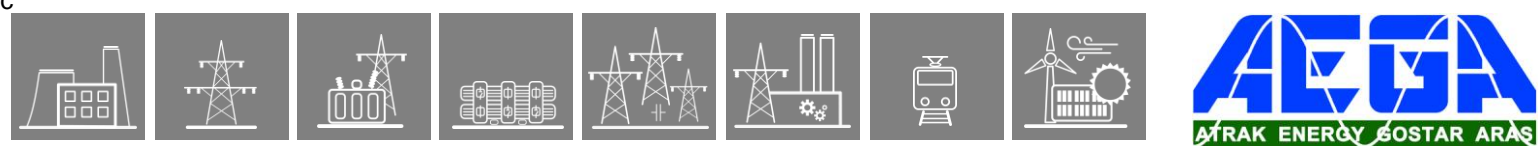

4.1.13.2.2. Function I/O

This section briefly describes the analogue and digital inputs and outputs of the function block.

4.1.13.2.2.1. Analogue inputs

The analogue inputs are the sampled values of the residual current.

4.1.13.2.2.2. Binary input signals (graphed output statuses)

The conditions of the binary inputs are defined by the user, applying the graphic equation editor (*Logic Editor*). Parts written in **bold** are seen on the left side of the function block in the Logic editor.

Table 2-2 The binary input signals of the residual IOC function

BINARY INPUT SIGNAL	SIGNAL TITLE	EXPLANATION
IOC50N_ Blk _GrO_	Block	Input for disabling the function
IOC50N_ Double _GrO_	Double	Input used to double the value of the parameter "Start Current".

4.1.13.2.2.3. Binary output signals (graphed input statuses)

These signals can be used in EuroCAP to assign to LED, user LCD object etc. Parts written in **bold** are seen on the right side of the function block in the *Logic Editor*.

Table 2-3 The binary output signals of the residual IOC function

BINARY OUTPUT SIGNAL	SIGNAL TITLE	EXPLANATION
IOC50N_ GenTr _GrI_	General Trip	General trip command of the function

4.1.13.2.2.4. Online data

The following values are visible in the *online data* page.

Table 2-4 Online data of the residual IOC function

SIGNAL TITLE	DIMENSION	EXPLANATION
General Trip	-	General trip command of the function

4.1.13.2.2.5. Events

The following events are generated in the event list, as well as sent to the SCADA according to the configuration.

Table 2-5 Generatable events of the residual IOC function

EVENT	VALUE	EXPLANATION
General Trip	off, on	General trip command of the function

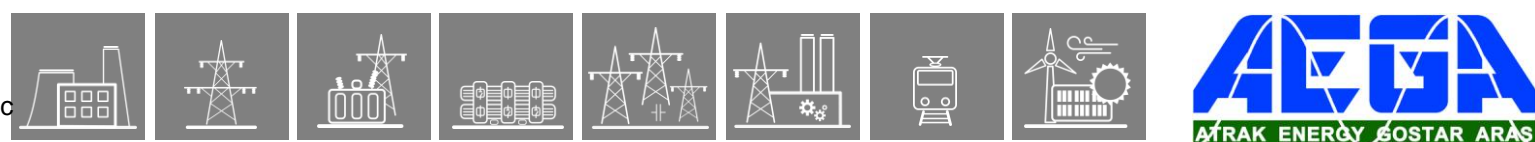

4.1.13.2.3. Technical Data

Table 2-6 Technical data of the residual IOC protection function

FUNCTION	VALUE	ACCURACY
<i>Using peak value calculation</i>		
Operating characteristic ($I > 0.1I_n$)	Instantaneous	< 6%
Reset ratio	0.85	
Operate time at $2 \cdot I_s$	< 15 ms	
Reset time*	< 40 ms	
Transient overreach	85%	
<i>Using Fourier fundamental harmonic calculation</i>		
Operating characteristic ($I > 0.1I_n$)	Instantaneous	< 3%
Reset ratio	0.85	
Operate time at $2 \cdot I_s$	< 25 ms	
Reset time*	< 60 ms	
Transient overreach	15%	

* Measured with signal contacts

4.1.13.2.4. Notes for Testing

Normally in the EuroProt+ devices the trip contacts are assigned to the Trip Logic function block, and not to the protection function blocks. Because of this, the testing personnel must make sure that the Trip Logic is switched on ('Operation' parameter is set to other than 'Off') before starting the tests, otherwise there will be no physical trip on the relay.

Being an instantaneous function, its connection to the Trip Logic function is done in the Fast Equations (by default) and not in the Logic Editor (usually, there are comments inserted in the Logic Editor if such connections exist). This can be checked in EuroCAP.

As the analogue sources can be changed by the user, it is possible to assign calculated or measured residual current to the input of the function block. This can be checked in the function block properties in EuroCAP.

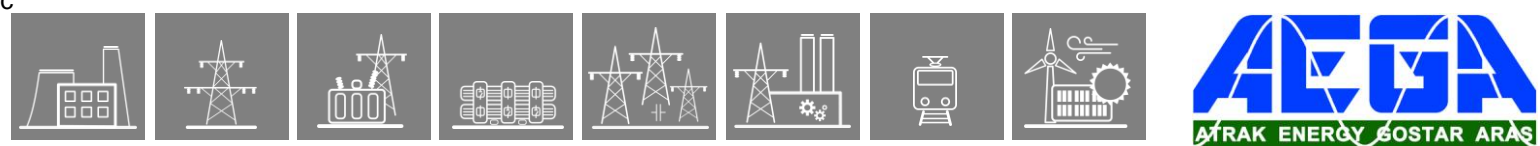

4.1.14. Breaker failure protection

4.1.14.1. Application

After a protection function generates a trip command, it is expected that the circuit breaker opens and the fault current drops below the pre-defined normal level.

If not, then an additional trip command must be generated for all backup circuit breakers to clear the fault. At the same time, if required, a repeated trip command can be generated to the circuit breaker(s) which are expected to open.

The breaker failure protection function can be applied to perform this task.

In EuroProt+ product family two versions of breaker failure protection function can be applied:

“BRF50” – Breaker Failure:

This version of the breaker failure protection can be applied to perform the task to give command to the backup circuit breakers. It can be applied if only common-phase handling is sufficient, and phase selectivity is not required.

BRF50SP

“BRF50SP” - Single-pole Breaker Failure:

If repeated trip command (retrip) is needed besides the backup trip, this version of breaker failure protection function must be used.

Both versions of breaker failure protection function receive the trip requirements of the protective functions implemented in the device and combines the binary signals and parameters to the outputs of the device.

4.1.14.1.1. Mode of operation

The starting signal of the breaker failure protection function is usually the trip command of any other protection function. The user has the task to define these starting signals using the graphic equation editor as the “General Start” (BRF50_GenSt_GrO_), or if the operation of the individual phases is needed, then the start signals for the phases individually.

The phase start signals are: “Start L1” (BRF50_StL1_GrO_), “Start L2” (BRF50_StL2_GrO_) and “Start L3” (BRF50_StL3_GrO_).

Dedicated timers start at the rising edge of the start signals, one for the backup trip command and one for the repeated trip command, separately for operation in the individual phases. During the running time of the timers the function optionally monitors the currents, the closed state of the circuit breakers or both, according to the user’s choice. The selection is made using the enumerated parameter “Operation”:

- If this parameter setting is “Current”, the current limit values “Start Ph Current” and “Start Res Current” must be set correctly. The binary input indicating the status of the circuit breaker has no meaning.
- If this parameter setting is “Contact”, the current limit values “Start current Ph” and “Start current N” have no meaning. The binary input indicating the status of the circuit breaker must be programmed correctly using the graphic equation editor.
 - *By using “BRF50” variant:* the input variable to be programmed is: **BRF50_CBClosed_GrO_** (CB Closed),
 - *By using “BRF50SP” variant:* the input variables to be programmed are: **BRF50_CBCIL1_GrO_** (CB closed L1), **BRF50_CBCIL2_GrO_** (CB closed L2) and **BRF50_CBCIL3_GrO_** (CB closed L3).
- If this parameter setting is “Current/Contact”, the current parameters and the status signal must be set correctly. The breaker failure protection function resets only if all conditions for faultless state are fulfilled.

BRF50SP

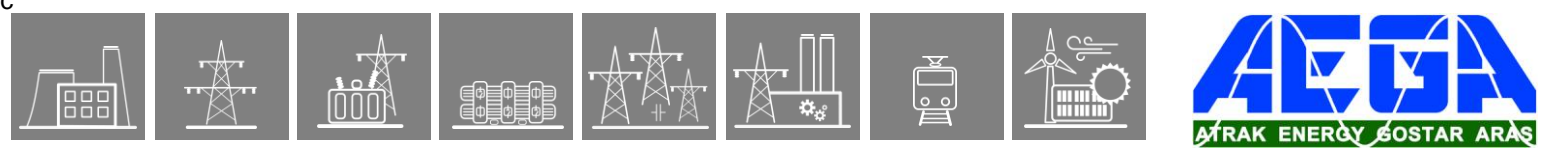

- The breaker failure protection function can be disabled by setting this parameter to “Off”. If at the end of the running time of the backup timer the currents do not drop below the pre-defined level, and/or the monitored circuit breaker is still in closed position, then a backup trip command is generated. The time delay is defined using the parameter “Backup Time Delay”.

The pulse duration of the trip command is not shorter than the time defined by setting the parameter “Pulse Duration”.

If repeated trip command is to be generated for the circuit breakers that are expected to open, then the enumerated parameter “Retrip” must be set to “On”. In this case, at the end of the retrip timer(s) the delay of which is set by the timer parameter “Retrip Time Delay”, a repeated trip command is also generated in the phase(s) where the backup timer(s) run off.

BRF50SP

Dynamic blocking is possible using the binary input BRF50_**Bik**_GrO_ (Block). The conditions are to be programmed by the user, using the graphic equation editor.

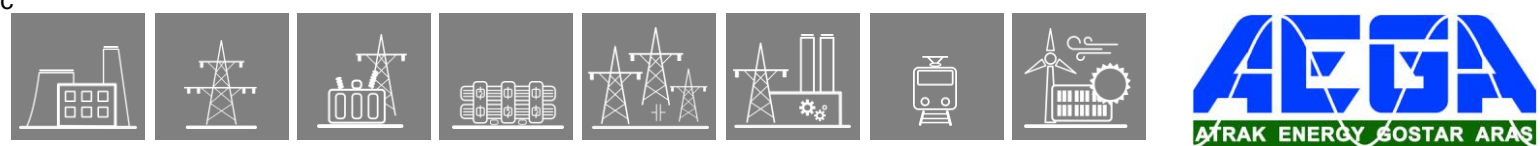

4.1.14.1.2. Operation principles

The decision logic module combines status signals, binary and enumerated parameters to generate the backup trip signal.

Binary status signals

The breaker failure protection function has binary input signals. **The conditions are defined by the user, applying the graphic equation editor.**

The **binary input status signals** of the breaker failure protection function are listed in [Table 1-1](#).

Table 1-1 The binary input status signals of the decision logic

BINARY STATUS SIGNAL	TITLE	EXPLANATION
BRF50_Blk_GrO_	Block	Blocking of the breaker failure protection function
BRF50_CBClosed_GrO_	CB closed	Signal indicating the closed state of the circuit breaker
BRF50SP_CBCIL1_GrO_	CB closed L1	Signal indicating the closed state of the circuit breaker in phase L1
BRF50SP_CBCIL2_GrO_	CB closed L2	Signal indicating the closed state of the circuit breaker in phase L2
BRF50SP_CBCIL3_GrO_	CB closed L3	Signal indicating the closed state of the circuit breaker in phase L3
BRF50_GenSt_GrO_	General Start	General starting signal
BRF50SP_StL1_GrO_	Start L1	Starting signal in phase L1
BRF50SP_StL2_GrO_	Start L2	Starting signal in phase L2
BRF50SP_StL3_GrO_	Start L3	Starting signal in phase L3
BRF50_loSt_GrO_	Start lo	Starting signal for the residual current
Internal signal:	IL1>	Current in phase L1 is above the preset parameter value
Internal signal:	IL2>	Current in phase L2 is above the preset parameter value
Internal signal:	IL3>	Current in phase L3 is above the preset parameter value
Internal signal:	lo>	Current 3lo is above the preset parameter value
Enumerated parameter	Current/Contact	The monitored condition is current, contact or both

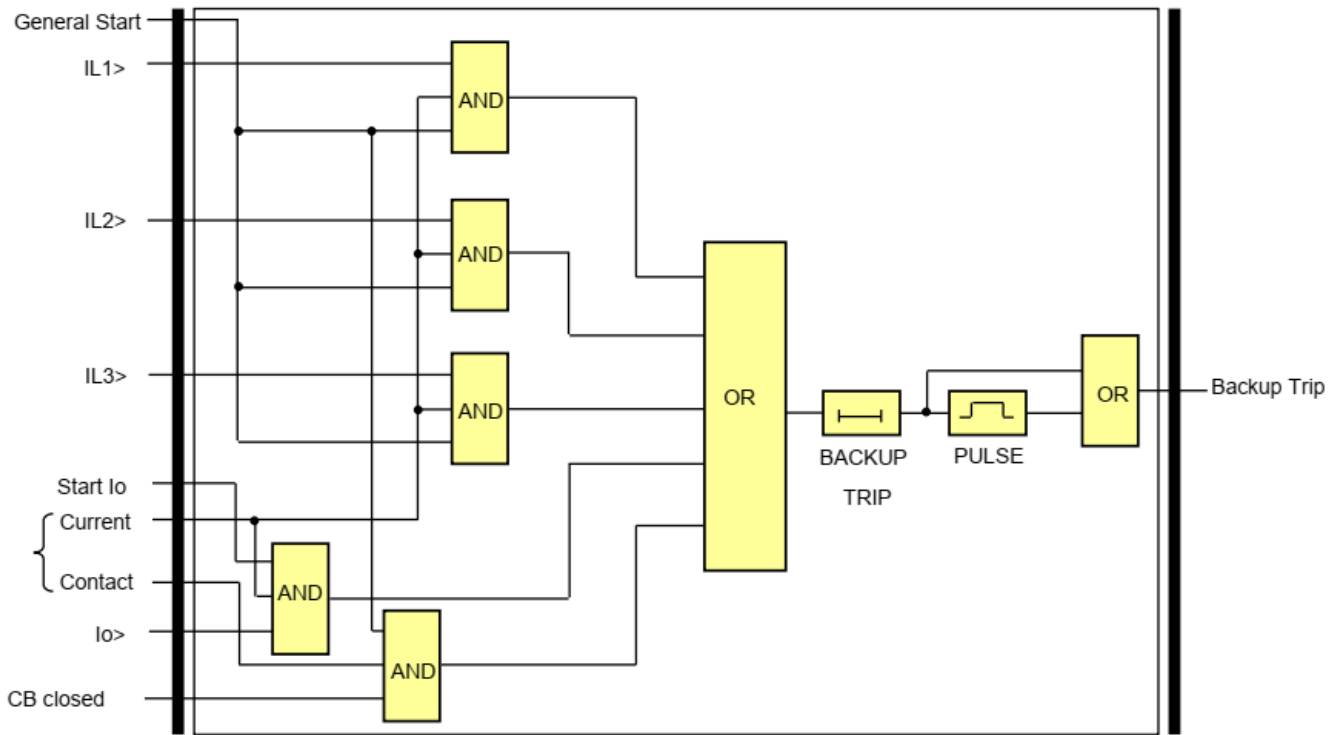

Figure 1-1 The logic scheme of the decision logic of "BRF50" variant

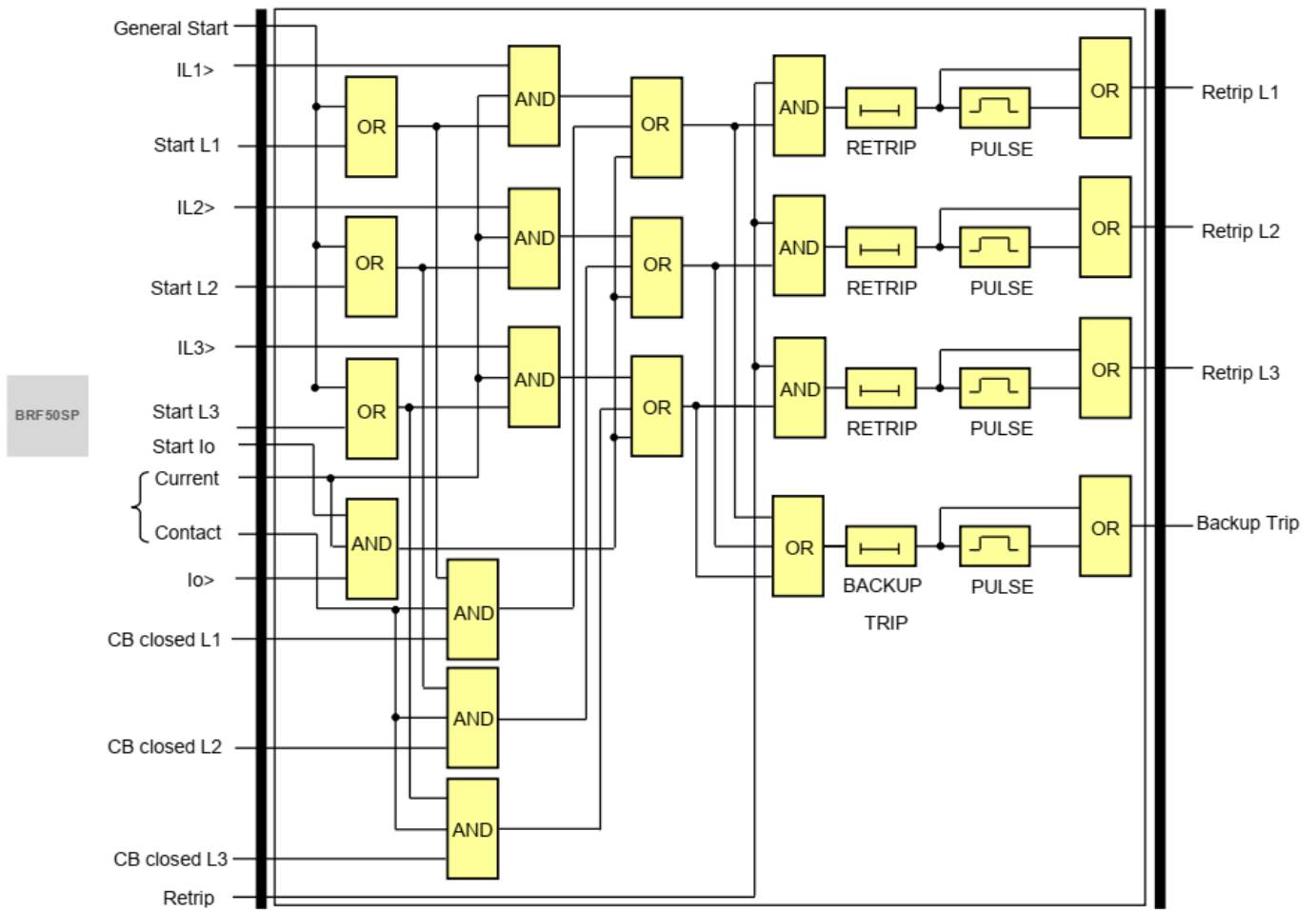
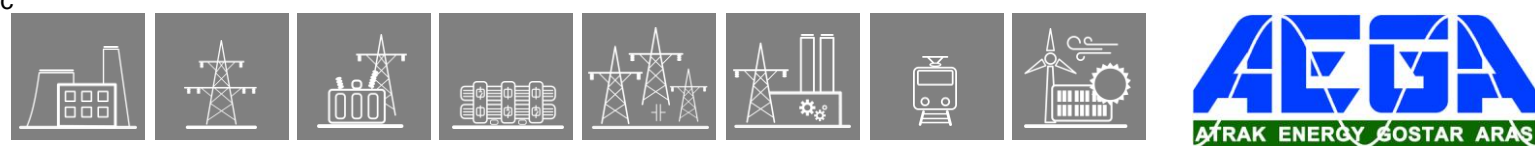

Figure 1-2 The logic scheme of the decision logic of "BRF50SP" variant



The **binary output status signals** of the breaker failure protection function is detailed in Table 1-2.

Table 1-2 The binary output status signal of the decision logic

BRF50SP

BINARY STATUS SIGNAL	TITLE	EXPLANATION
BRF50_BuTr_Grl_	Backup Trip	Trip command generated for the backup circuit breakers
BRF50_TrL1_Grl_	Retrip L1	Repeated trip command in phase L1
BRF50_TrL2_Grl_	Retrip L2	Repeated trip command in phase L2
BRF50_TrL3_Grl_	Retrip L3	Repeated trip command in phase L3

4.1.14.2. Breaker failure protection function overview

The graphic appearance of the variants the breaker failure protection function blocks are shown below. The blocks show all binary input and output status signals which are applicable in the graphic equation editor.

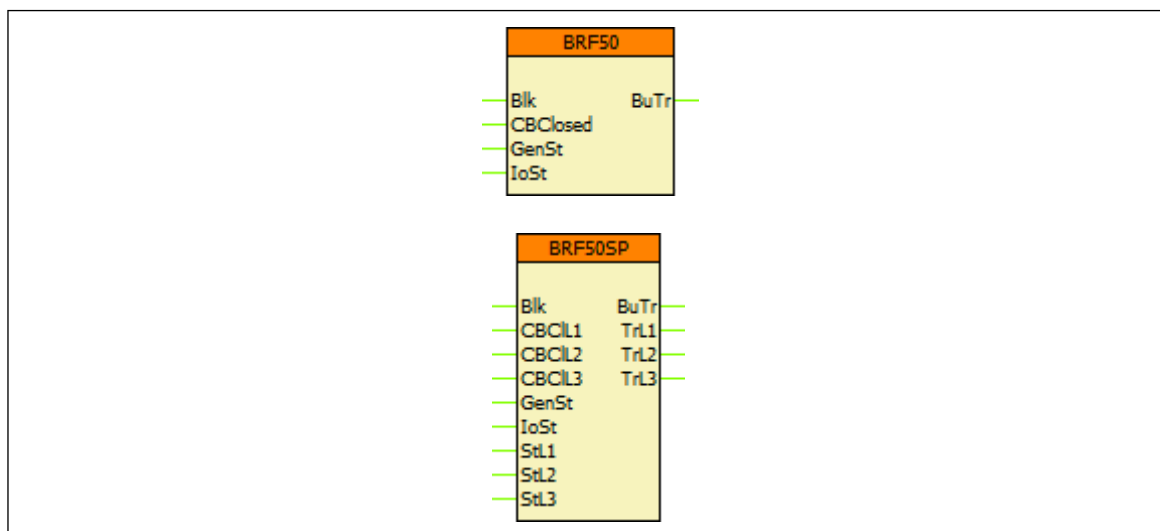

Figure 2-1 Graphic appearance of the variants of the breaker failure protection function block

4.1.14.2.1. Settings

4.1.14.2.1.1. Parameters

The available parameters are listed below in order of their appearance in the *parameters* menu. If the setting range of a parameter should be extended, contact Protecta Support.

Table 2-1 Parameters of the breaker failure protection function

	TITLE	DIM	RANGE	STEP	DEFAULT	EXPLANATION
	Operation	-	Off, Current, Contact, Current/Contact	-	Off	Enabling the function
BRF50SP	Retrip	-	Off, On	-	Off	Enabling the retrip function
	Start Ph Current	%	20 – 200	1	30	Phase current setting
	Start Res Current	%	10 – 200	1	20	Residual current setting
BRF50SP	Retrip Time Delay	msec	0 – 1000	1	100	Time delay for retrip command generation
	Backup Time Delay	msec	100 – 60000	1	1000	Time delay for trip command generation for the backup circuit breaker(s)
	Pulse Duration	msec	0 – 60000	1	100	Trip command impulse duration

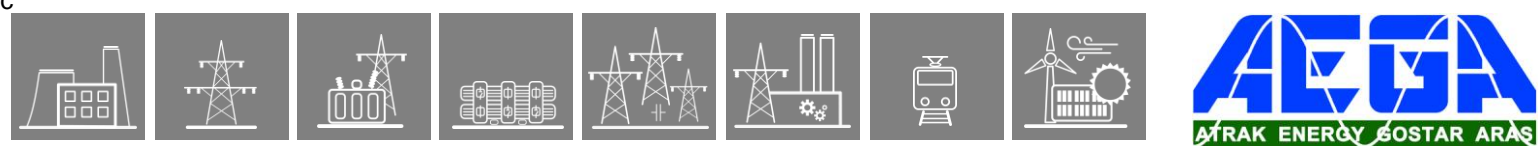

4.1.14.2.2. Function I/O

This section describes briefly the analogue and digital inputs and outputs of the function block.

4.1.14.2.2.1. Analogue inputs

The function uses the sampled values of a current input. This is defined in the configuration.

4.1.14.2.2.2. Binary input signals (graphed output statuses)

The conditions of the binary inputs are defined by the user, applying the graphic equation editor (*Logic Editor*). Parts written in **bold** are seen on the left side function block in the Logic editor.

Table 2-2 The binary input signals of the breaker failure protection functions

BINARY STATUS SIGNAL	TITLE	EXPLANATION
BRF50_ Bik _GrO_	Block	Blocking of the breaker failure protection function
BRF50_ CBClosed _GrO_	CB closed	Signal indicating the closed state of the circuit breaker
<i>BRF50SP_ CBCIL1_GrO_</i>	<i>CB closed L1</i>	<i>Signal indicating the closed state of the circuit breaker in phase L1</i>
<i>BRF50SP_ CBCIL2_GrO_</i>	<i>CB closed L2</i>	<i>Signal indicating the closed state of the circuit breaker in phase L2</i>
<i>BRF50SP_ CBCIL3_GrO_</i>	<i>CB closed L3</i>	<i>Signal indicating the closed state of the circuit breaker in phase L3</i>
BRF50_ GenSt _GrO_	General Start	General starting signal
<i>BRF50SP_ StL1_GrO_</i>	<i>Start L1</i>	<i>Starting signal in phase L1</i>
<i>BRF50SP_ StL2_GrO_</i>	<i>Start L2</i>	<i>Starting signal in phase L2</i>
<i>BRF50SP_ StL3_GrO_</i>	<i>Start L3</i>	<i>Starting signal in phase L3</i>
BRF50_ IoSt _GrO_	Start Io	Starting signal for the residual current

4.1.14.2.2.3. Binary output signals (graphed input statuses)

These signals can be used in EuroCAP to assign to LED, user LCD object etc. Parts written in **bold** are seen on the right side of the function block in the *Logic Editor*.

Table 2-3 The binary output signals of the breaker failure protection function

BINARY STATUS SIGNAL	TITLE	EXPLANATION
BRF50_ BuTr _GrI_	Backup Trip	Trip command generated for the backup circuit breakers
<i>BRF50_ TrL1_GrI_</i>	<i>Retrip L1</i>	<i>Repeated trip command in phase L1</i>
<i>BRF50_ TrL2_GrI_</i>	<i>Retrip L2</i>	<i>Repeated trip command in phase L2</i>
<i>BRF50_ TrL3_GrI_</i>	<i>Retrip L3</i>	<i>Repeated trip command in phase L3</i>

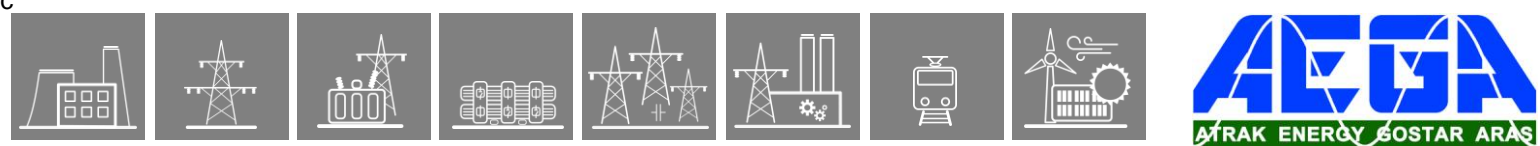

4.1.14.2.2.4. Online data

Visible values on the *online data* page.

Table 2-4 Online displayed data of the breaker failure protection function

	SIGNAL TITLE	DIMENSION	EXPLANATION
	Backup Trip	-	Trip command generated for the backup circuit breakers
BRF50SP	<i>Retrip L1</i>	-	<i>Repeated trip command in phase L1</i>
	<i>Retrip L2</i>	-	<i>Repeated trip command in phase L2</i>
	<i>Retrip L3</i>	-	<i>Repeated trip command in phase L3</i>

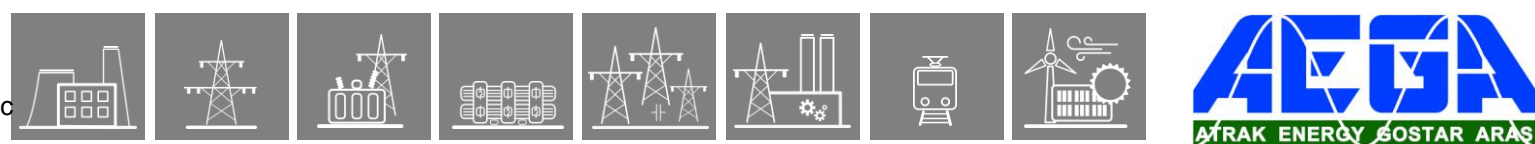

4.1.14.2.2.5. Events

The following events are generated in the event list, as well as sent to the SCADA according to the configuration.

Table 2-5 Generated events of the breaker failure protection function

EVENT	VALUE	EXPLANATION
Backup Trip	off, on	Backup trip command of the function
<i>Retrip L1</i>	off, on	<i>Repeated trip command in phase L1</i>
<i>Retrip L2</i>	off, on	<i>Repeated trip command in phase L2</i>
<i>Retrip L3</i>	off, on	<i>Repeated trip command in phase L3</i>

BRF50SP

4.1.14.2.3. Technical data

Table 2-6 Technical data of the breaker failure protection function

FUNCTION	VALUE	ACCURACY
Pick-up starting accuracy		< 2 %
Operate time accuracy		±5% or ±15 ms, whichever is greater
Retrip time	approx. 15 ms	
Reset ratio	0.9	
Current reset time	16 – 25 ms	

4.1.14.2.4. Notes for testing

Note that the time delay parameter incorporates the algorithm time as well, so the time delay **does not mean the time difference between the appearance of the start and trip signals** of the function. In other words: it is not the delay between the detection of the fault and the trip that follows it. This should be taken into consideration when checking the disturbance records.

Instead the time delay parameter defines the elapsed time from the appearance of the faulty state to the trip. Because of this, while testing, the delay measurement should start *from the moment of the fault injection* until the trip signal.

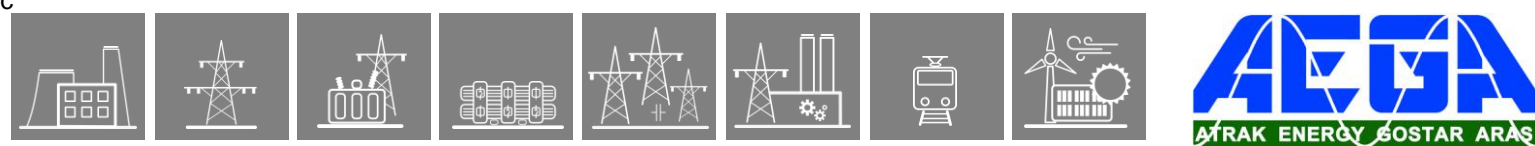

4.1.15. Three-phase time overcurrent protection

4.1.15.1. Operation principle

The overcurrent protection function realizes definite time or inverse time characteristics according to IEC or IEEE standards, based on three phase currents. The characteristics are harmonized with IEC 60255-151, Edition 1.0, 2009-08. This function can be applied as main protection for medium-voltage applications or backup or overload protection for high-voltage network elements.

4.1.15.1.1. Operating characteristics

4.1.15.1.1.1. Independent time characteristic

$$t(G) = t_{OP} \text{ when } G > G_S$$

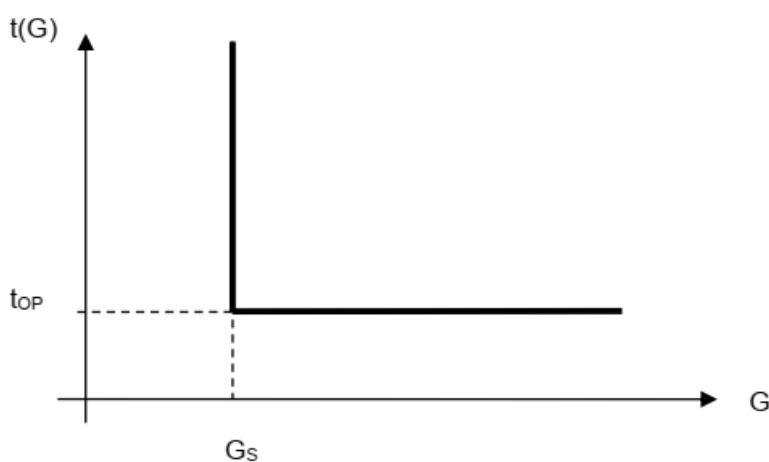
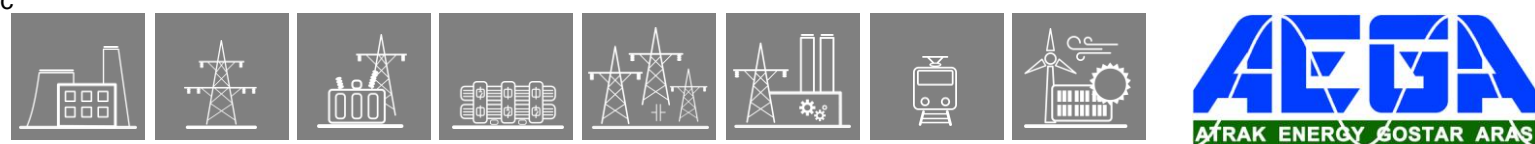

Figure 1-1 Overcurrent independent time characteristic

where

- t_{OP} (seconds) theoretical operating time if $G > G_S$, fix, according to the preset parameter,
- G measured value of the characteristic quantity, Fourier base harmonic of the phase currents,
- G_S preset value of the characteristic quantity ("Start current" parameter).



Additionally, a minimum time delay can be defined by parameter “Min Time Delay”. This delay is valid if it is longer than $t(G)$, defined by the formula above.

The inverse characteristic is valid above $G_T = 1,1 * G_s$. Above this value the function is guaranteed to operate.

Resetting characteristics:

- For IEC type characteristics the resetting is after a fix time delay defined by “Reset delay”,
- for ANSI types however according to the formula below:

$$t_r(G) = TMS \left[\frac{k_r}{1 - \left(\frac{G}{G_s}\right)^\alpha} \right] \text{ when } G < G_s$$

where

- $t(G)$ (seconds) theoretical reset time with constant value of G ,
- k_r constants characterizing the selected curve (in seconds),
- α constants characterizing the selected curve (no dimension),
- G measured value of the characteristic quantity, Fourier base harmonic of the phase currents,
- G_s preset value of the characteristic quantity (“Start current” parameter),
- TMS preset time multiplier (no dimension).

Table 1-2 The resetting constants of the standard dependent time characteristics

	IEC REF	TITLE	k_r	α
1	A	IEC Inv	Resetting after fix time delay, according to preset parameter “Reset delay”	
2	B	IEC VeryInv		
3	C	IEC ExtInv		
4		IEC LongInv		
5		ANSI Inv	0,46	2
6	D	ANSI ModInv	4,85	2
7	E	ANSI VeryInv	21,6	2
8	F	ANSI ExtInv	29,1	2
9		ANSI LongInv	4,6	2
10		ANSI LongVeryInv	13,46	2
11		ANSI LongExtInv	30	2

4.1.15.1.2. Structure of the overcurrent protection algorithm

Fig.1-2 shows the structure of the overcurrent protection (TOC51) algorithm.

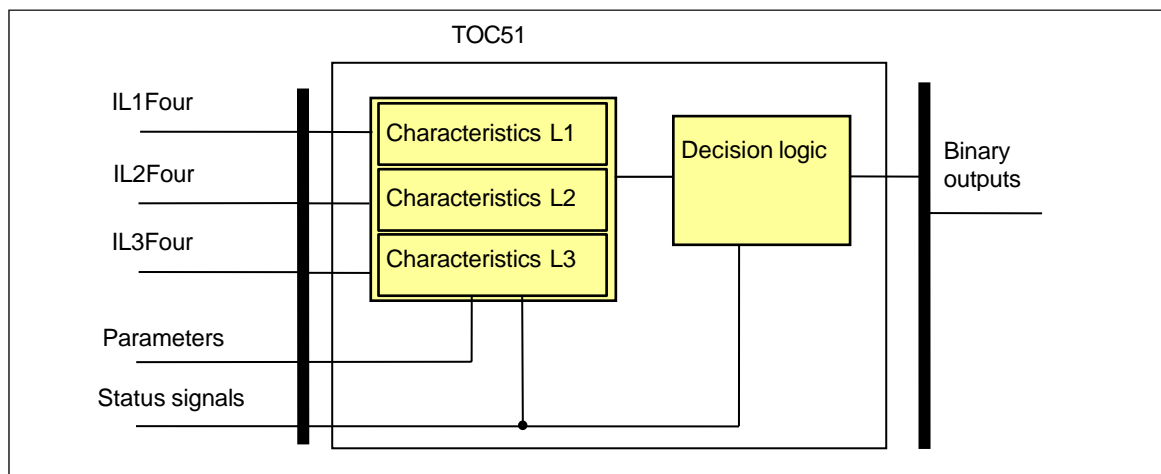

Figure 1-2 Structure of the overcurrent protection algorithm

The **inputs** are

the RMS value of the fundamental Fourier component of three phase currents, parameters, status signals.

The **outputs** are

the binary output status signals.

The **software modules** of the overcurrent protection function:

Characteristics

This module calculates the required time delay based on the Fourier components of the phase currents.

Decision logic

The decision logic module combines the status signals to generate the trip command of the function.

The following description explains the details of the individual components.

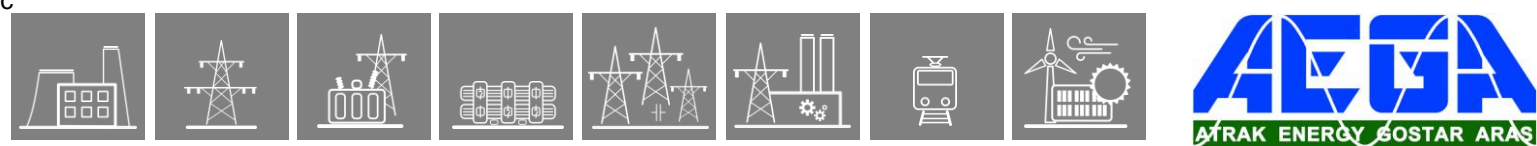

4.1.15.1.3. The definite time and the inverse type characteristics (characteristics)

This module calculates the required time delay based on the Fourier components of the phase currents. The formulas applied are described in Chapter 1.1.

The **inputs** are the RMS value of the fundamental Fourier component of the phase currents (IL1Four, IL2Four, IL3Four) and parameters.

The **outputs** are the status signals of the three phases individually. These indicate the started state and the generated trip command if the time delay determined by the characteristics expired.

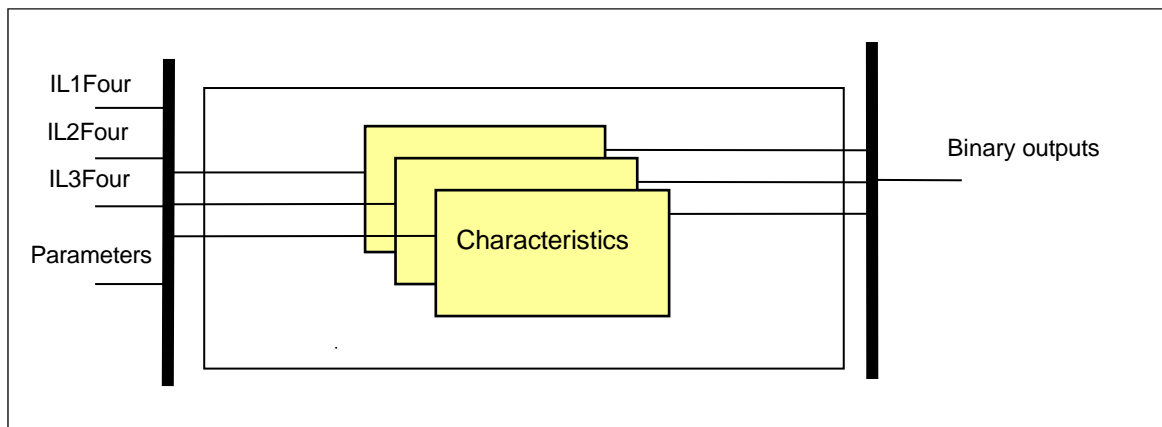

Figure 1-3 Schema of the characteristic calculation

The inverse type characteristics are also presented graphically on the following pages. These diagrams assume 100% setting value for the Start current parameter (GS), 1 for the Time multiplier (TMS) and 0 for the Min. time delay.

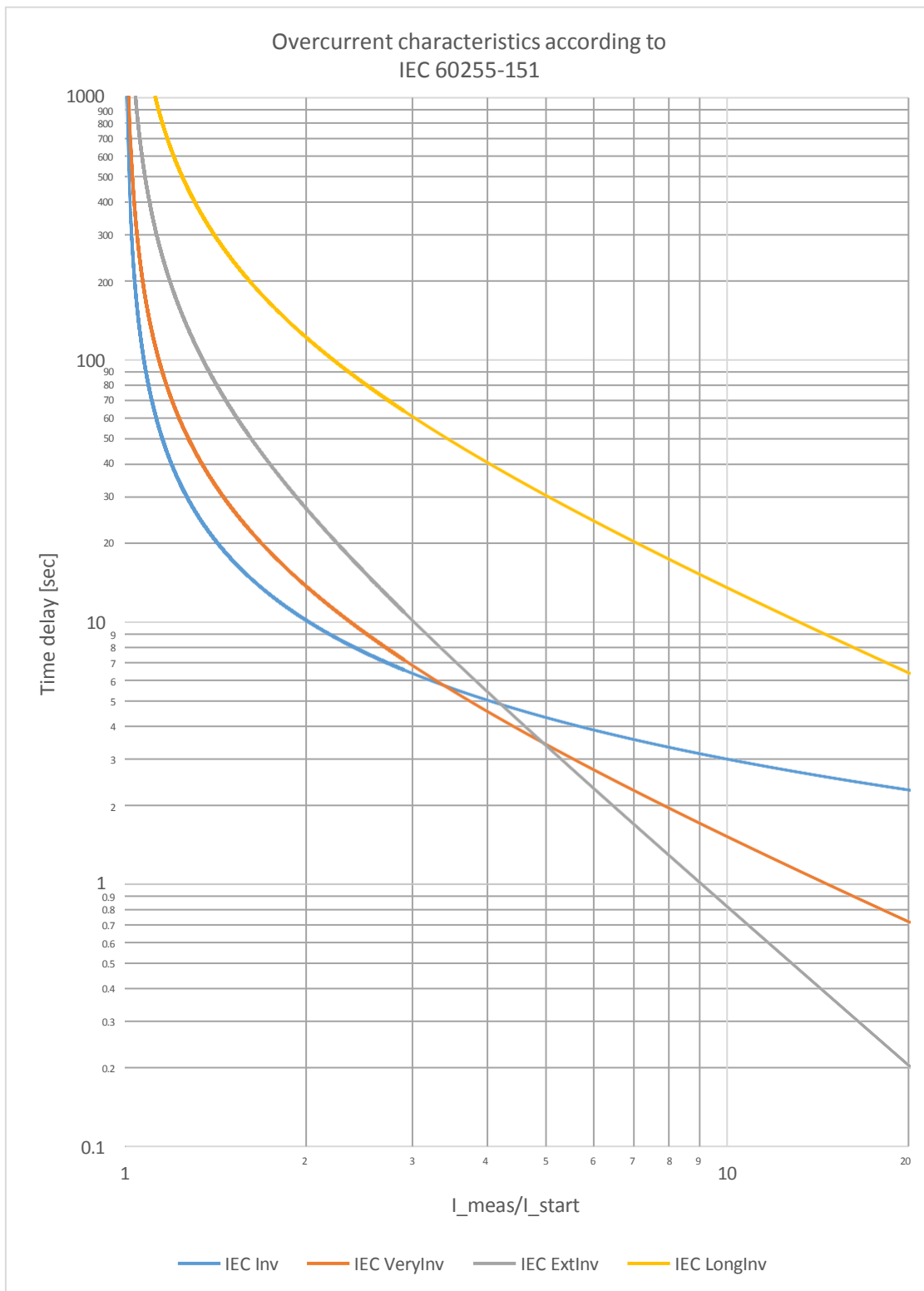

Figure 1-4 Overcurrent characteristics according to IEC 60255-151

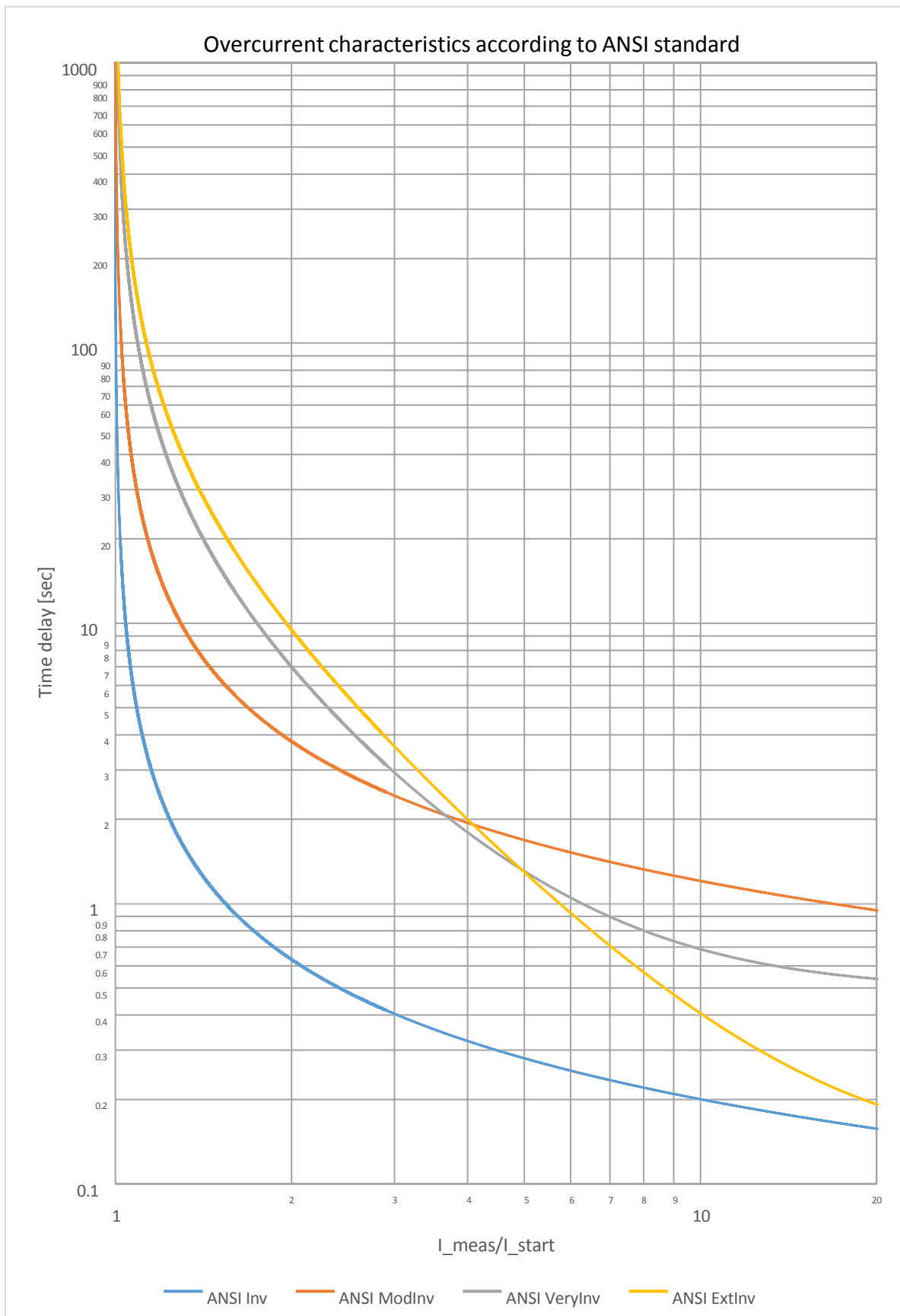

Figure 1-5 Overcurrent characteristics according to ANSI standard

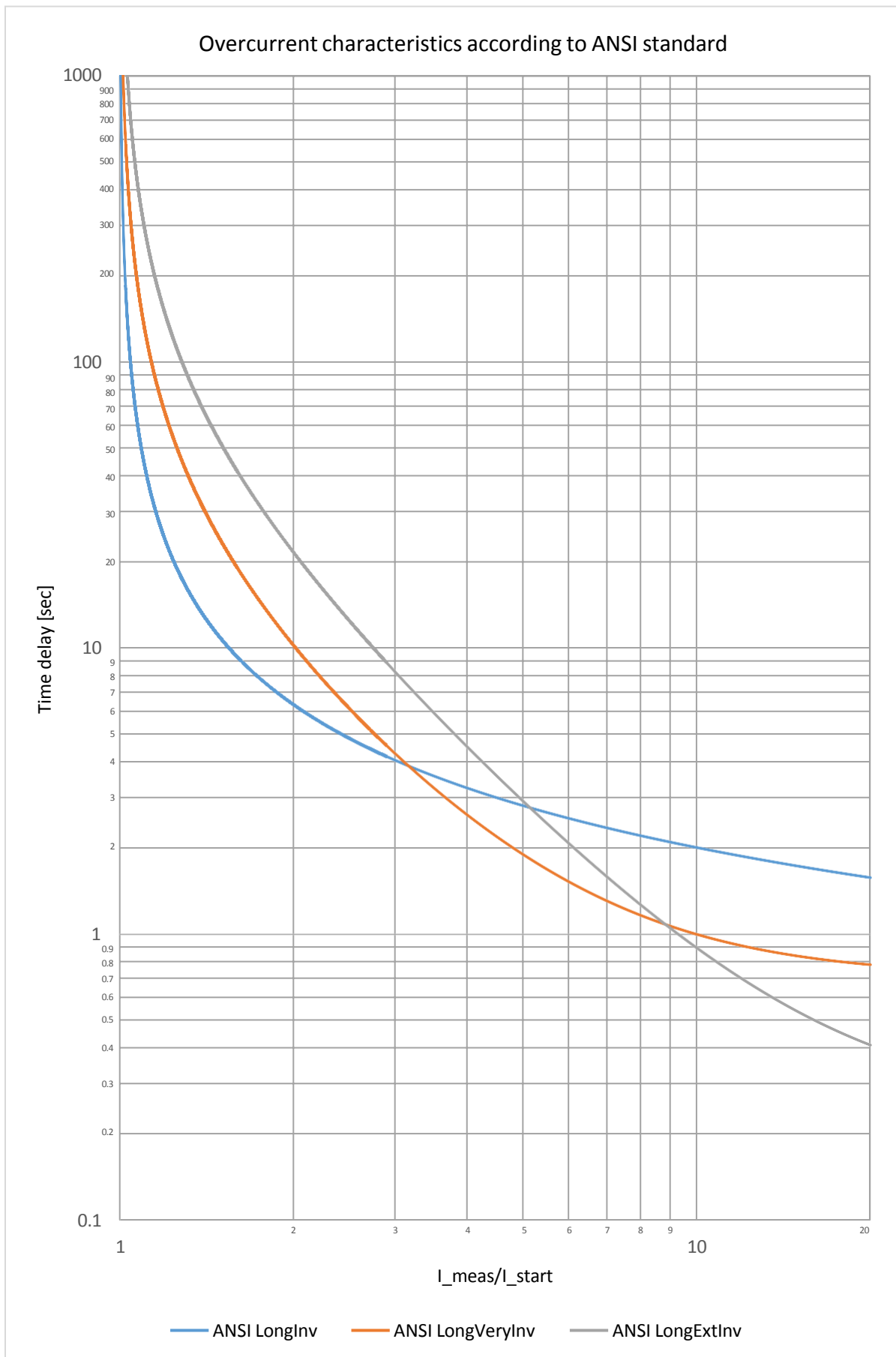

Figure 1-6 Overcurrent characteristics according to ANSI standard

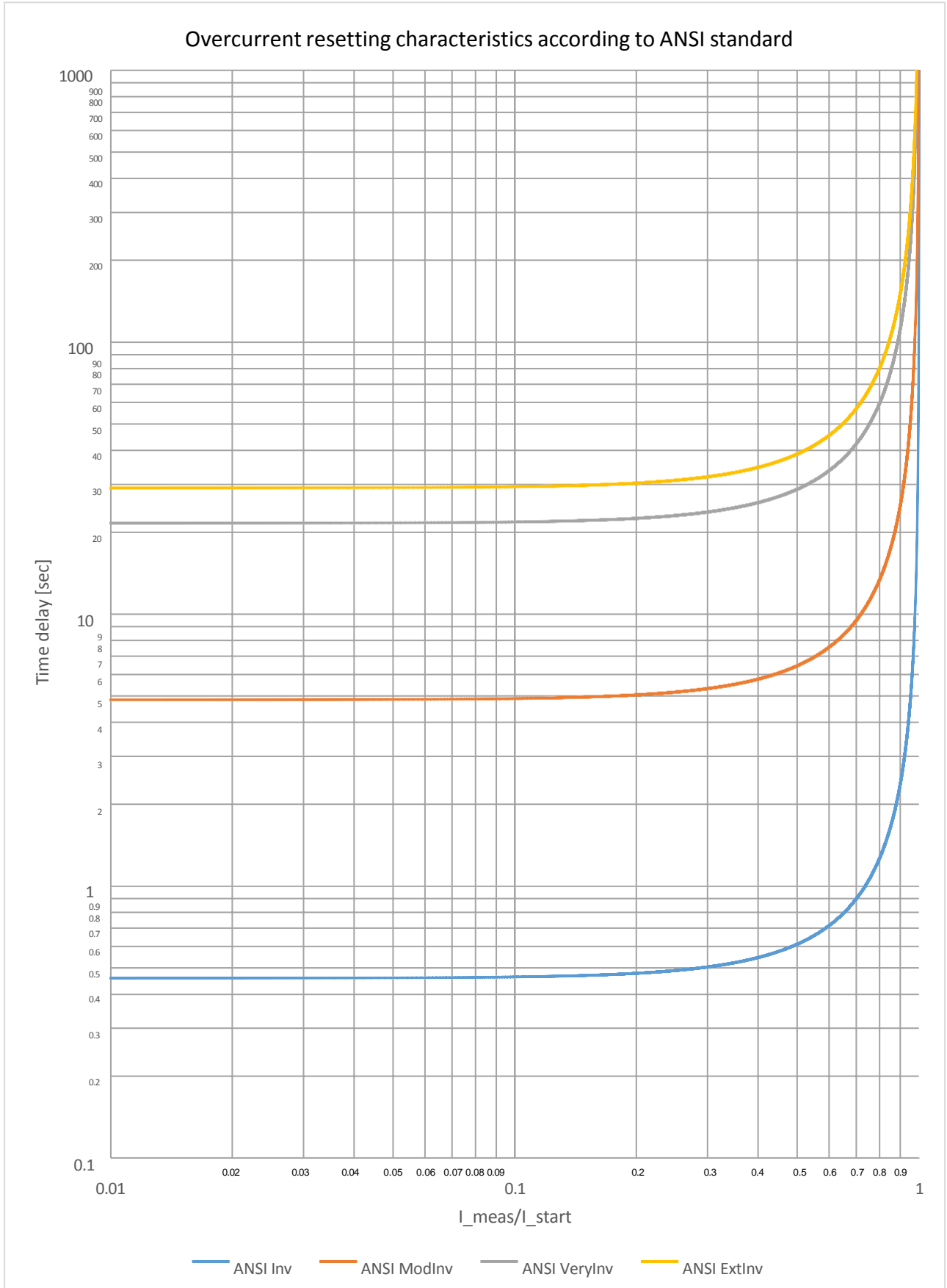

Figure 1-7 Overcurrent resetting characteristics according to ANSI standard

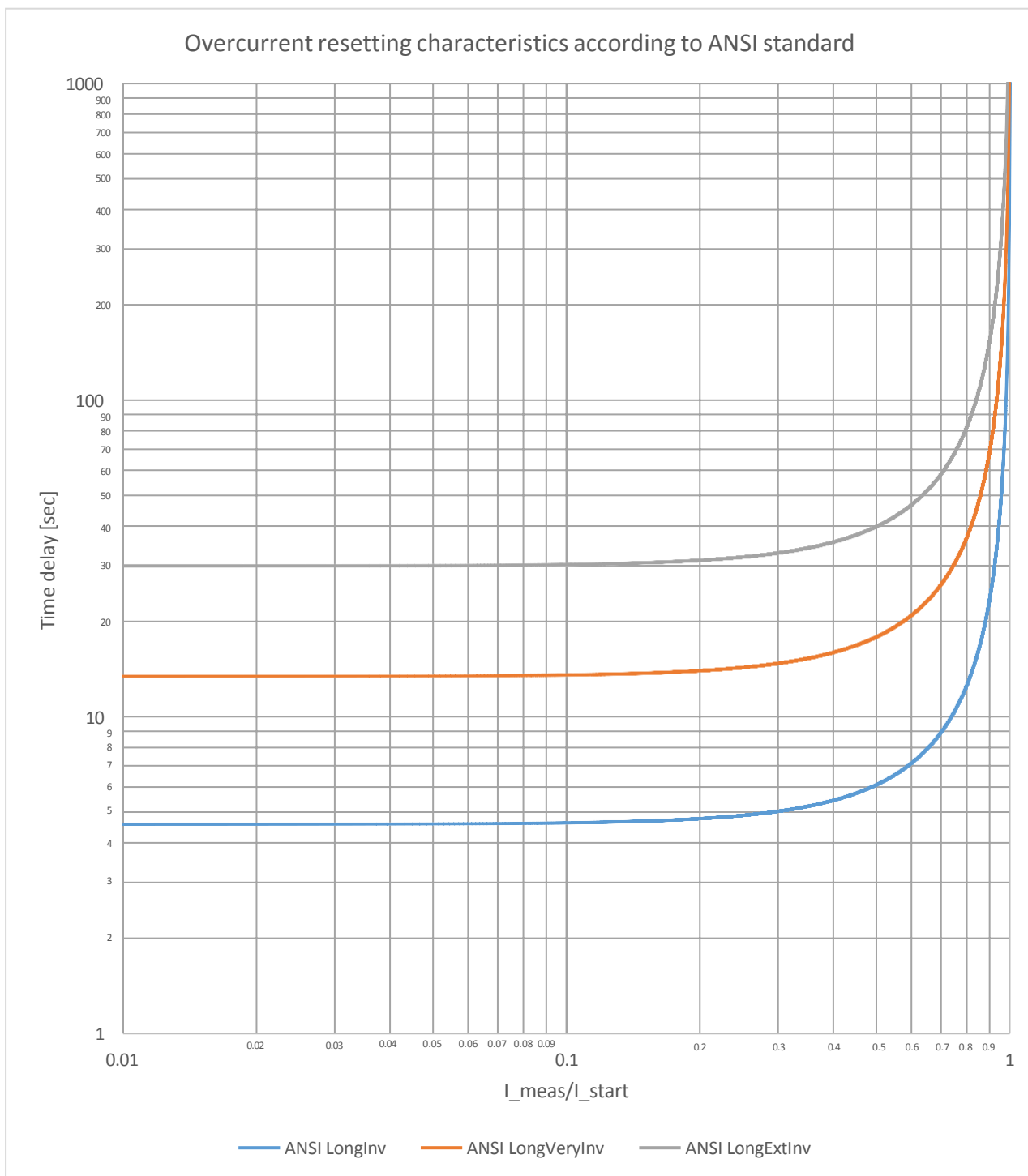

Figure 1-8 Overcurrent resetting characteristics according to ANSI standard

4.1.15.1.4. The decision logic (Decision logic)

The decision logic module combines the status signals to generate the general start signal and general trip command of the function.

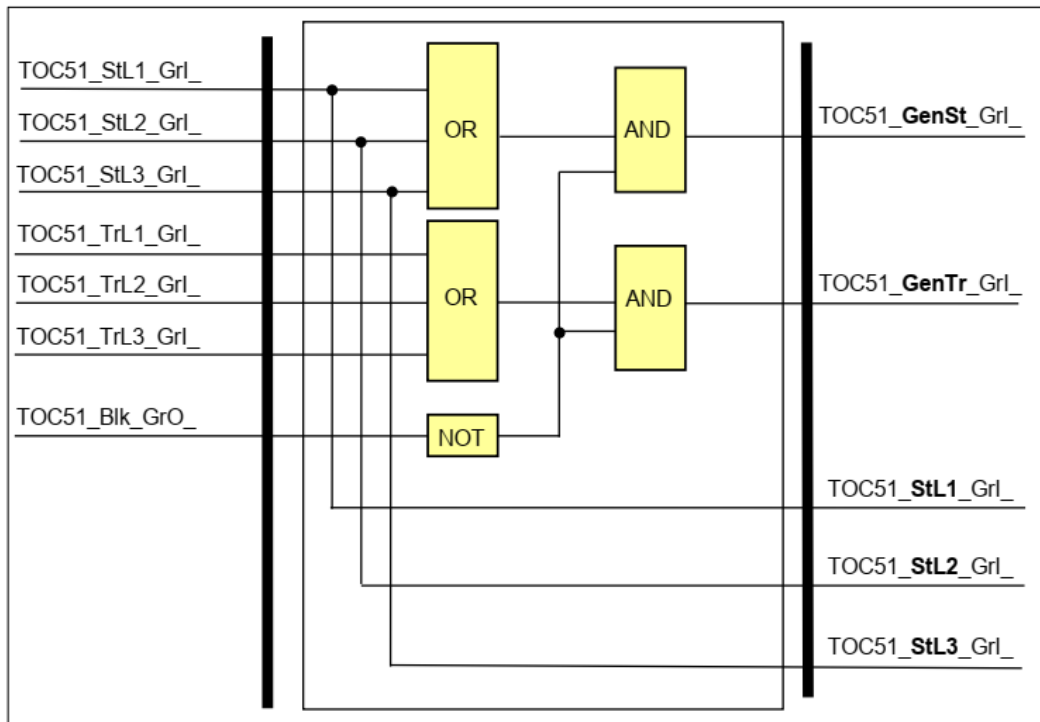
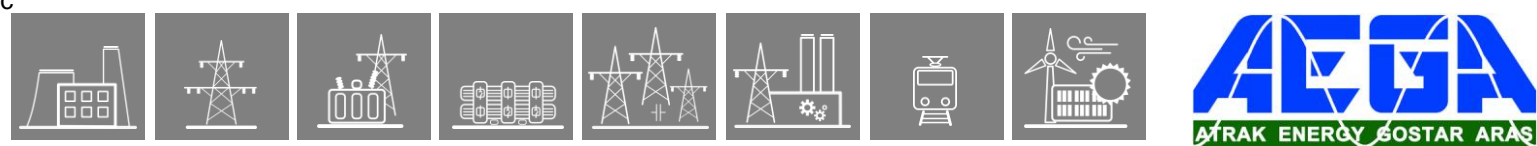

Figure 1-9 The logic scheme of the overcurrent protection function

Table 1-3 The binary input status signals of the overcurrent protection function

BINARY INPUT SIGNALS	SIGNAL TITLE	EXPLANATION
TOC51_StL1_Gr_	Start L1	Starting of the function in phase L1
TOC51_TrL1_Gr_	Trip L1	Trip command of the function in phase L1
TOC51_StL2_Gr_	Start L2	Starting of the function in phase L2
TOC51_TrL2_Gr_	Trip L2	Trip command of the function in phase L2
TOC51_StL3_Gr_	Start L3	Starting of the function in phase L3
TOC51_TrL3_Gr_	Trip L3	Trip command of the function in phase L3



Binary status signals

The overcurrent protection function has a binary input signal, which serves the purpose of disabling the function. **The conditions of disabling are defined by the user, applying the graphic equation editor.**

Table 1-4 The binary input signal of the overcurrent protection function

BINARY STATUS SIGNAL	EXPLANATION
TOC51_Blk_GrO_	Output status of a graphic equation defined by the user to disable the overcurrent protection function.

Table 1-5 The binary output status signals of the overcurrent protection function

BINARY OUTPUT SIGNALS	SIGNAL TITLE	EXPLANATION
TOC51_StL1_Grl_	Start L1	Starting of the function in phase L1
TOC51_StL2_Grl_	Start L2	Starting of the function in phase L2
TOC51_StL3_Grl_	Start L3	Starting of the function in phase L3
TOC51_GenSt_Grl_	Gen. Start	General starting of the function
TOC51_GenTr_Grl_	Gen. Trip	General trip command of the function

4.1.15.2. 3ph overcurrent protection function overview

The function block of the three-phase overcurrent protection function is shown in Figure 2-1. This block shows all binary input and output status signals that are applicable in the graphic equation editor.

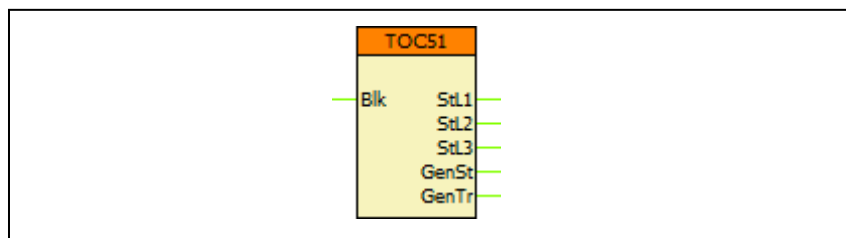

Figure 2-1 The function block of the overcurrent protection function

4.1.15.2.1. Settings

4.1.15.2.1.1. Parameters

Table 2-1 Parameters of the 3ph overcurrent protection function

TITLE	DIM	RANGE	STEP	DEFAULT	EXPLANATION
Operation	-	Off, Definite Time, IEC Inv, IEC VeryInv, IEC ExtInv, IEC LongInv, ANSI Inv, ANSI ModInv, ANSI VeryInv, ANSI ExtInv, ANSI LongInv, ANSI LongVeryInv, ANSI LongExtInv	-	Off	Enabling the function by choosing the characteristics.
Start Current	%	10 – 3000	1	200	Starting current of the function.
Time Multiplier	-	0.05 – 15.0	0.01	200	Time multiplier of the inverse characteristics (OC module)
Min Time Delay	msec	40 – 60000	1	100	Minimal time delay for the inverse characteristics
Definite Time Delay	msec	40 – 60000	1	100	Time delay setting for the definite time characteristics
Reset Time	msec	60 – 60000	1	100	Reset time for the IEC inverse characteristics

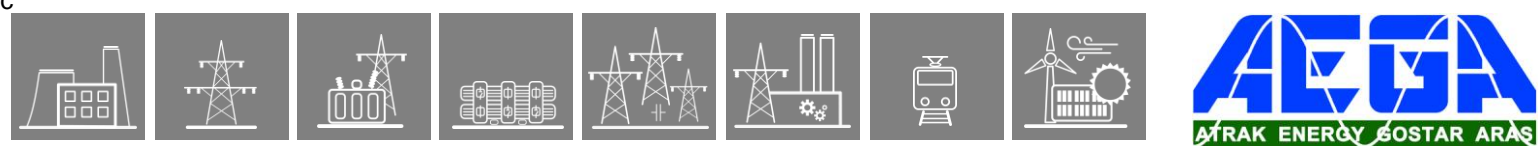

4.1.15.2.2. Function I/O

This section describes briefly the analogue and digital inputs and outputs of the function block.

4.1.15.2.2.1. Analogue inputs

The function uses the sampled values of the three phase currents.

4.1.15.2.2.2. Binary output signals (graphed input statuses)

The **binary output status signals** of the three-phase overcurrent protection function are listed in Table 2-2. **Parts** written in **bold** are seen on the function block in the logic editor.

Table 2-2 The binary output status signals of the 3ph overcurrent protection function

BINARY OUTPUT SIGNALS	SIGNAL TITLE	EXPLANATION
TOC51_ St L1_Grl_	Start L1	Starting of the function in phase L1
TOC51_TrL1_Grl_	Trip L1	Trip command of the function in phase L1
TOC51_ St L2_Grl_	Start L2	Starting of the function in phase L2
TOC51_TrL2_Grl_	Trip L2	Trip command of the function in phase L2
TOC51_ St L3_Grl_	Start L3	Starting of the function in phase L3
TOC51_TrL3_Grl_	Trip L3	Trip command of the function in phase L3
TOC51_ GenSt _Grl_	General Start	General start of the function
TOC51_ GenTr _Grl_	General Trip	General trip command of the function

4.1.15.2.2.3. Binary input signals (graphed output statuses)

The overcurrent protection function has a binary input signal, which serves the purpose of disabling the function. **The conditions of disabling are defined by the user, applying the graphic equation editor.**

Table 2-3 The binary input status signals of the 3ph overcurrent protection function

BINARY INPUT SIGNAL	EXPLANATION
TOC51_ BIk _GrO_	Output status of a graphic equation defined by the user to disable the overcurrent protection function.

4.1.15.2.2.4. On-line data

Visible values on the on-line data page:

Table 2-4 On-line data of the 3ph overcurrent protection function

SIGNAL TITLE	DIMENSION	EXPLANATION
Start L1	-	Starting of the function in phase L1
Trip L1	-	Trip command of the function in phase L1
Start L2	-	Starting of the function in phase L2
Trip L2	-	Trip command of the function in phase L2
Start L3	-	Starting of the function in phase L3
Trip L3	-	Trip command of the function in phase L3
General Start	-	General start of the function
General Trip	-	General trip command of the function

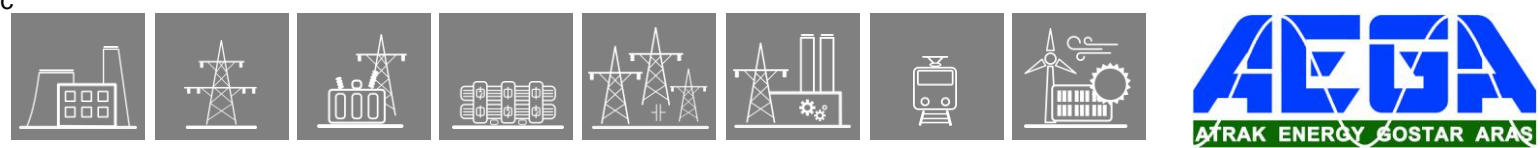

4.1.15.2.2.5. Events

The following events are generated in the event list, as well as sent to SCADA according to the configuration.

Table 2-5 Events of the 3ph overcurrent protection function

EVENT	VALUE	EXPLANATION
Start L1	off, on	Start of the three-phase overcurrent protection function in measuring element L1
Start L2	off, on	Start of the three-phase overcurrent protection function in measuring element L2
Start L3	off, on	Start of the three-phase overcurrent protection function in measuring element L3
General Start	off, on	General start of the three-phase overcurrent protection function
General Trip	off, on	General trip command of the three-phase overcurrent protection function

4.1.16. Residual overcurrent protection function

The residual overcurrent protection function can realize definite time or inverse time characteristics according to IEC or IEEE standards, based on the RMS value of the fundamental Fourier component of a single measured current, which can be the measured residual current at the neutral point ($3I_0$) or the calculated zero sequence current component. The characteristics are harmonized with IEC 60255-151, Edition 1.0, 2009-08.

4.1.16.1. Operating characteristics

4.1.16.1.1. Independent time characteristic

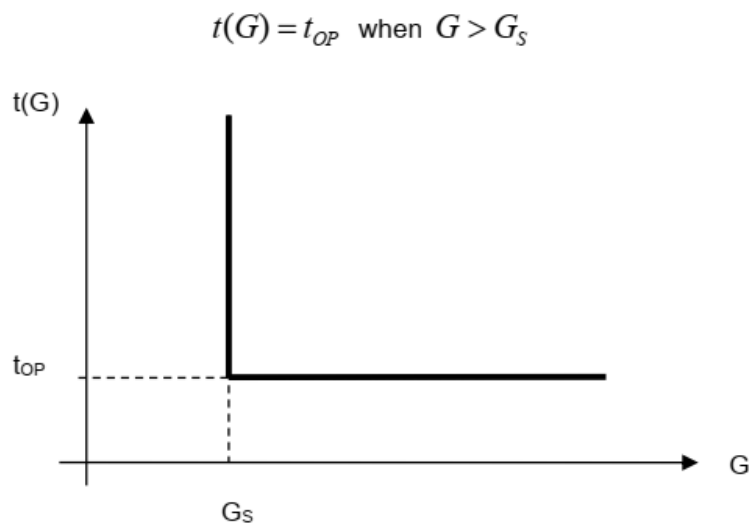

Figure 1-1 Overcurrent independent time characteristic

where	
t_{OP} (seconds)	theoretical operating time if $G > G_s$, fix, according to the preset parameter,
G	measured value of the characteristic quantity, Fourier base harmonic of the residual current,
G_s	preset value of the characteristic quantity (TOC51N_StCurr_IPar_, Start current).

4.1.16.1.2. Standard dependent time characteristics

Operating characteristics:

$$t(G) = TMS \left[\frac{k_r}{\left(\frac{G}{G_s}\right)^\alpha - 1} + c \right] \text{ when } G > G_s$$

where

t(G)(seconds)

k_r, c

α

G

G_s

TMS

theoretical operate time with constant value of G,
 constants characterizing the selected curve (in seconds),
 constant characterizing the selected curve (no dimension),
 measured value of the characteristic quantity, Fourier base harmonic
 of the residual current (INFour),
 preset value of the characteristic quantity (TOC51N_StCurr_IPar_
 Start current),
 preset time multiplier (no dimension).

	IEC ref		k _r	c	α
1	A	IEC Inv	0,14	0	0,02
2	B	IEC VeryInv	13,5	0	1
3	C	IEC ExtInv	80	0	2
4		IEC LongInv	120	0	1
5		ANSI Inv	0,0086	0,0185	0,02
6	D	ANSI ModInv	0,0515	0,1140	0,02
7	E	ANSI VeryInv	19,61	0,491	2
8	F	ANSI ExtInv	28,2	0,1217	2
9		ANSI LongInv	0,086	0,185	0,02
10		ANSI LongVeryInv	28,55	0,712	2
11		ANSI LongExtInv	64,07	0,250	2

Table 1-1 The constants of the standard dependent time characteristics

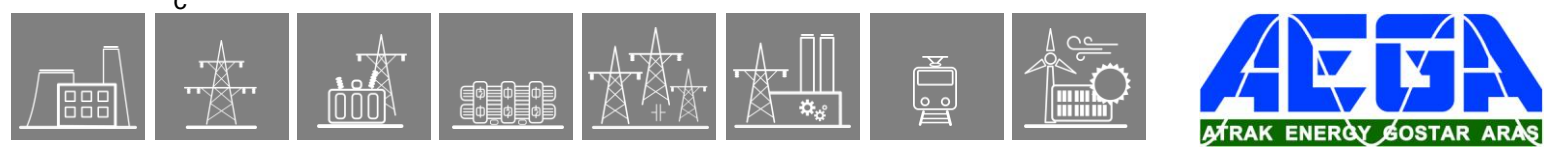

Resetting characteristics:

$$t_r(G) = TMS \left[\frac{k_r}{1 - \left(\frac{G}{G_s}\right)^\alpha} \right] \text{ when } G < G_s$$

where
 $t_r(G)$ (seconds) theoretical reset time with constant value of G,
 k_r constants characterizing the selected curve (in seconds),
 α constant characterizing the selected curve (no dimension),
 G measured value of the characteristic quantity, Fourier base harmonic of the residual current,
 G_s preset value of the characteristic quantity (TOC51N_StCurr_IPar_, Start current),
 TMS preset time multiplier (no dimension).

	IEC ref		k_r	α
1	A	IEC Inv	Resetting after fix time delay, according to preset parameter TOC51N_Reset_TPar_ "Reset delay"	
2	B	IEC VeryInv		
3	C	IEC ExtInv		
4		IEC LongInv		
5		ANSI Inv	0,46	2
6	D	ANSI ModInv	4,85	2
7	E	ANSI VeryInv	21,6	2
8	F	ANSI ExtInv	29,1	2
9		ANSI LongInv	4,6	2
10		ANSI LongVeryInv	13,46	2
11		ANSI LongExtInv	30	2

Table 1-2 The resetting constants of the standard dependent time characteristics

The inverse type characteristics are also combined with a minimum time delay, the value of which is set by user parameter TOC51N_MinDel_TPar_ (Min. Time Delay).

The end of the effective range of the dependent time characteristics (G_D) is:

$$G_D = 20 * G_s$$

Above this value the theoretical operating time is definite:

$$t(G) = TMS \left[\frac{k_r}{\left(\frac{G_D}{G_s}\right)^\alpha - 1} + c \right] \text{ when } G > G_D = 20 * G_s$$

The combined logic requires expiry both the time defined by the inverse characteristic with the definite section AND the expiry of the minimum time defined by the "Min. Time Delay" parameter.

The inverse characteristic is valid above $G_T = 1,1 * G_s$. Above this value the function is guaranteed to operate.

4.1.16.2. Structure of the residual overcurrent protection algorithm

Fig.1-2 shows the structure of the residual overcurrent protection (TOC51N) algorithm.

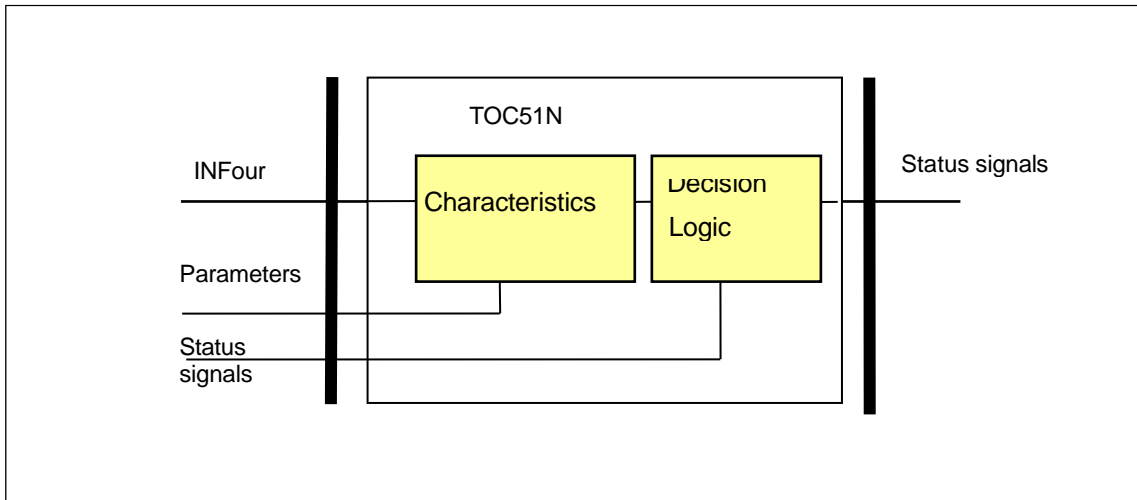

Figure 1-2 Structure of the residual overcurrent protection algorithm

The **inputs** are

- the RMS value of the fundamental Fourier component of the residual current ($I_N=3I_0$),
- parameters,
- status signals.

The **outputs** are

- the binary output status signals.

The **software modules** of the residual overcurrent protection function:

Characteristics

This module calculates the required time delay based on the RMS value of the fundamental Fourier component of the residual current.

Decision logic

The decision logic module combines the status signals to generate the trip command of the function.

The following description explains the details of the individual components.

4.1.16.3. The definite time and the inverse type characteristics

This module calculates the required time delay based on the Fourier components of the residual current. The formulas applied are described in Chapter 1.1.

The **inputs** are the basic Fourier components of the residual current (INFour) and parameters.

The **outputs** are the internal status signals of the function. These indicate the started state and the generated trip command if the time delay determined by the characteristics expired.

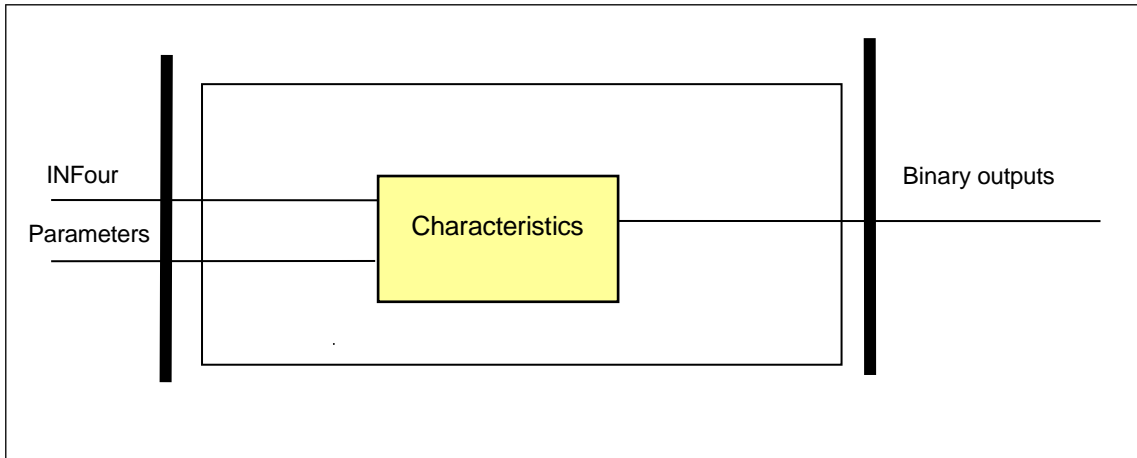

Figure 1-3 Schema of the characteristic calculation

Enumerated parameter

Parameter name	Title	Selection range	Default
Parameter for type selection			
TOC51N_Oper_EPar_	Operation	Off, DefinitTime, IEC Inv, IEC VeryInv, IEC ExtInv, IEC LongInv, ANSI Inv, ANSI ModInv, ANSI VeryInv, ANSI ExtInv, ANSI LongInv, ANSI LongVeryInv, ANSI LongExtInv	Off

Table 1-3 The enumerated parameters of the residual overcurrent protection function

Integer parameters

Parameter name	Title	Unit	Min	Max	Step	Default
Starting current parameter:						
TOC51N_StCurr_IPar_	Start Current *	%	10	1000	1	50
TOC51N_StCurr_IPar_	Start Current **	%	5	1000	1	50

* In = 1 A or 5 A

** In = 200 mA or 1 A

Table 1-4 The integer parameters of the residual overcurrent protection function

Float parameter

Parameter name	Title	Unit	Min	Max	Step	Default
Time multiplier of the inverse characteristics (OC module)						
TOC51N_Multip_FPar_	Time Multiplier		0.05	15	0.01	1.0

Table 1-5 Float parameter of the OC function block

Timer parameters

Parameter name	Title	Unit	Min	Max	Step	Default
Minimal time delay for the inverse characteristics:						
TOC51N_MinDel_TPar_	Min Time Delay *	msec	40	60000	1	100
Definite time delay:						
TOC51N_DefDel_TPar_	Definite Time Delay **	msec	40	60000	1	100
Reset time delay for the inverse characteristics:						
TOC51N_Reset_TPar_	Reset Time*	msec	60	60000	1	100

*Valid for inverse type characteristics only

**Valid for definite type characteristics only

Table 1-6 Timer parameters of the residual overcurrent protection function

The **binary output status signals** of the residual overcurrent protection function are listed in [Table 1-7](#).

Binary output signals	Signal title	Explanation
TOC51N_St_Grl_	Start L1	Starting of the function
TOC51N_Tr_Grl_	Trip L1	Trip command of the function

Table 1-7 The binary output status signals of the residual overcurrent protection function

4.1.16.4. The decision logic (Decision logic)

The decision logic module combines the status signals to generate the trip command of the function.

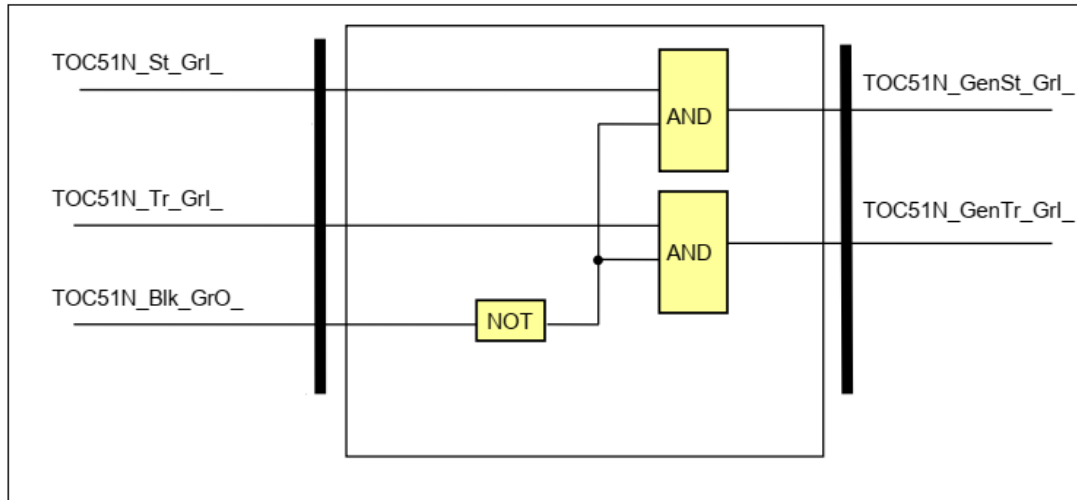

Figure 1-4 The (simplified) logic scheme of the residual overcurrent protection function

Binary input signals	Signal title	Explanation
TOC51N_St_Grl_	Start	Starting of the function
TOC51N_Tr_Grl_	Trip	Trip command of the function

Table 1-8 The binary input status signals of the residual overcurrent protection function

Binary status signals

The residual overcurrent protection function has a binary input signal, which serves the purpose of disabling the function. **The conditions of disabling are defined by the user, applying the graphic equation editor.**

Binary status signal	Explanation
TOC51N_Blk_GrO_	Output status of a graphic equation defined by the user to disable the residual overcurrent protection function.

Table 1-9 The binary input signal of the residual overcurrent protection function

Binary output signals	Signal title	Explanation
TOC51N_GenSt_Grl_	General Start	General starting of the function
TOC51N_GenTr_Grl_	General Trip	General trip command of the function

Table 1-10 The binary output status signals of the residual overcurrent protection function

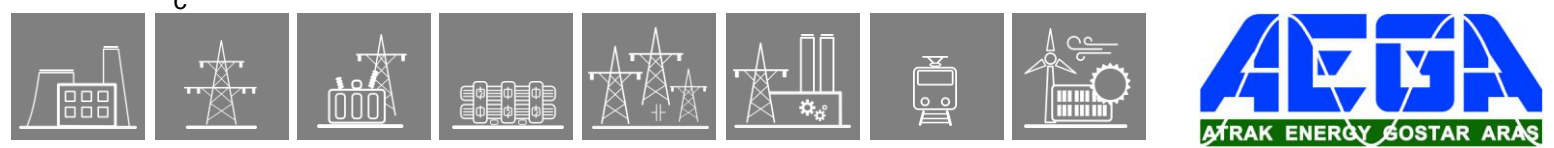

4.1.16.5. Technical summary

4.1.16.5.1. Technical data

Function	Value	Accuracy
Operating accuracy *	$20 \leq G_s \leq 1000$	< 3 %
Operate time accuracy		$\pm 5\%$ or ± 15 ms, whichever is greater
Reset ratio	0,95	
Reset time * Dependent time char. Definite time char.	Approx 60 ms	< 5% or ± 35 ms, whichever is greater
Transient overreach		2 %
Pickup time	≤ 40 ms	
Overshot time Dependent time char. Definite time char.	30 ms 50 ms	
Influence of time varying value of the input current (IEC 60255-151)		< 4 %

* Measured in version $I_n = 200$ mA

Table 1-11 Technical data of the residual overcurrent protection function

4.1.16.5.2. The parameters

The parameters are summarized in Chapter [1.3](#).

4.1.16.5.3. The binary input status signals

Binary input signal

The residual overcurrent protection function has a binary input signal, which serves the purpose of disabling the function. **The conditions of disabling are defined by the user, applying the graphic equation editor.**

Binary input signal	Explanation
TOC51N_Blk_GrO_	Output status of a graphic equation defined by the user to disable the residual overcurrent protection function.

Table 1-12 The binary input signal of the residual overcurrent protection function

4.1.16.5.4. The binary output status signals

The **binary output status signals** of the residual overcurrent protection function are listed in Table 1-13.

Binary output signals	Signal title	Explanation
TOC51N_GenSt_Grl_	General Start	General starting of the function
TOC51N_GenTr_Grl_	General Trip	General trip command of the function

Table 1-13 The binary output status signals of the residual overcurrent protection function

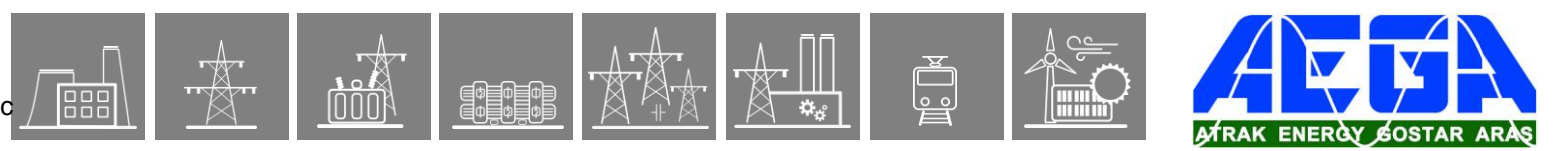

4.1.16.5.5. The function block

The function block of the residual overcurrent protection function is shown in [Figure 1-5](#). This block shows all binary input and output status signals that are applicable in the graphic equation editor.

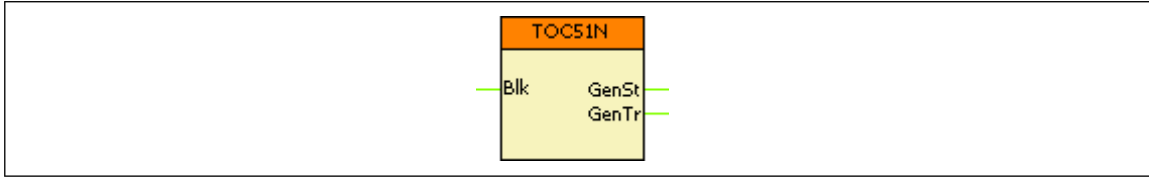

Figure 1-5 The function block of the residual overcurrent protection function

4.1.17. Definite time overvoltage protection function

4.1.17.1. Application

The definite time overvoltage protection function measures three voltages. If any of them is above the level defined by parameter setting, then a start signal is generated for the phases individually.

4.1.17.2. Mode of operation

The function generates start signals for the phases individually. The general start signal is generated if the voltage in any of the three measured voltages is above the level defined by parameter setting value.

Note that in medium voltage applications the function uses the phase-to-phase voltages by default.

The function generates a trip command only if the time delay has expired and the parameter selection requires a trip command as well.

4.1.17.3. Operating characteristics

$$t(G) = t_{OP} \text{ when } G > G_s$$

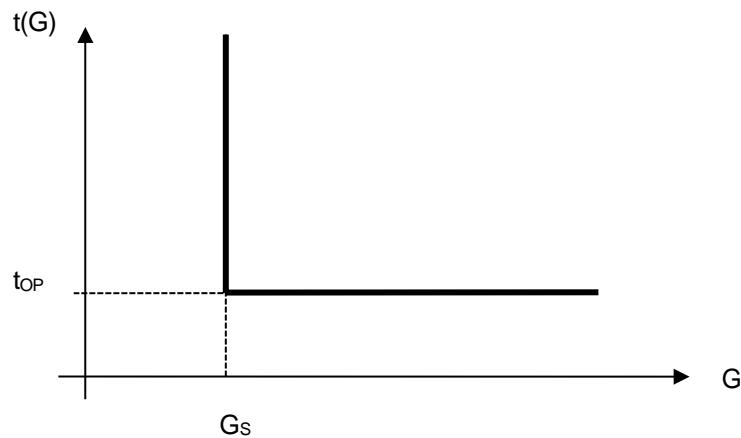

Figure 1-1 Overvoltage definite time characteristic

where
 t_{OP} (seconds) theoretical operating time if $G > G_s$, fix, according to the parameter setting,
 G measured value of the characteristic quantity, Fourier base harmonic of the phase voltages (or phase-to-phase voltages),
 G_s setting value of the characteristic quantity.

C

4.1.17.5. The Fourier calculation (Fourier)

These modules calculate the basic Fourier components of the phase voltages individually. They are not part of the TOV59 function; they belong to the preparatory phase.

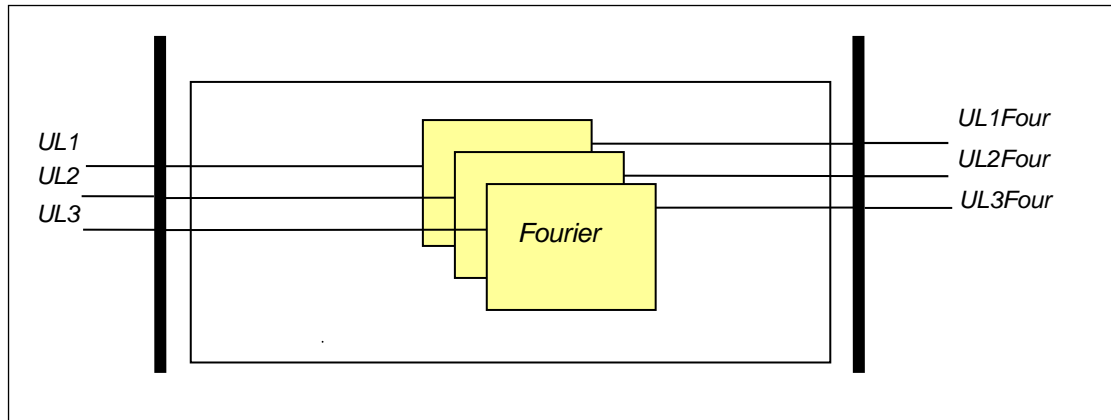

Figure 1-3 Schema of the Fourier calculation

The **inputs** are the sampled values of the three phase voltages (UL1, UL2, UL3)

The **outputs** are the RMS values of the basic Fourier components of the analyzed voltages (UL1Four, UL2Four, UL3Four).

The phase-to-phase voltages (if used) are also calculated here.

4.1.17.6. The definite time characteristics (Characteristics)

This module decides the stating of the function based on the Fourier components of the phase voltages and it counts the time delay. The time delay is defined by the parameter setting, if the voltages are above the setting value.

The **inputs** are the RMS values of the basic Fourier components of the phase (or the calculated phase-to-phase) voltages (UL1Four, UL2Four, UL3Four) and parameters.

The **outputs** are the status signals of the three phases individually. These indicate the started state and the generated trip command if the time delay determined by the setting is expired.

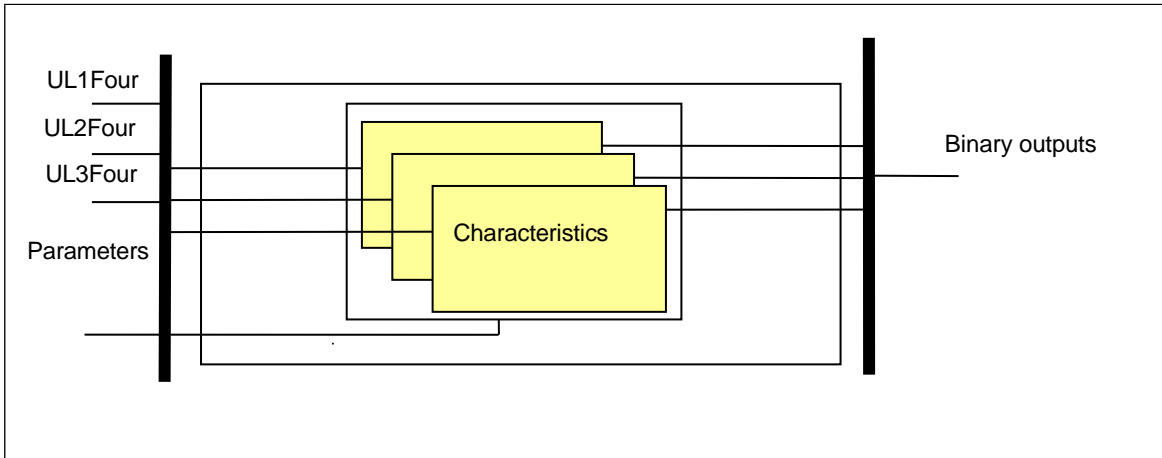

Figure 1-4 Schema of the definite time characteristic calculation

Enumerated parameter

Parameter name	Title	Selection range	Default
Enabling or disabling the overvoltage protection function			
TOV59_Oper_EPar_	Operation	Off, On	Off

Table 1-1 The enumerated parameter of the overvoltage protection function

Integer parameter

Parameter name	Title	Unit	Min	Max	Step	Default
Voltage level setting. If the measured voltage is above the setting value, the function generates a start signal.						
TOV59_StVol_IPar_	Start Voltage	%	30	130	1	110

Table 1-2 Integer parameter of the overvoltage protection function

Floating point parameter

Parameter name	Title	Unit	Min	Max	Step	Default
After starting the function drops off if the measured voltage is below the start voltage with at least this percentage.						
TOV59_ResetRatio_FPar_	Reset Ratio	%	1	10	1	5

Table 1-3 Floating point parameter of the overvoltage protection function

4.1.17.7. The decision logic (Decision logic)

The decision logic module combines binary signals and Boolean parameters to generate the trip command of the function.

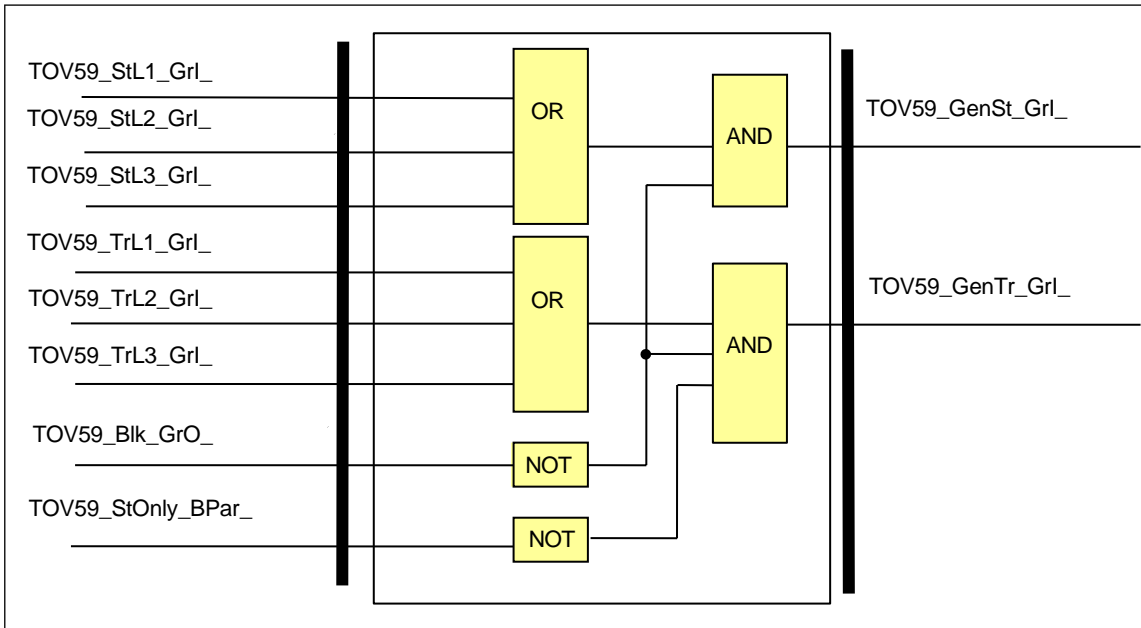

Figure 1-5 The decision logic scheme of the definite time overvoltage protection function

Binary input signal	Signal title	Explanation
TOV59_StL1_Grl_	StL1	Starting of the function in phase L1*
TOV59_TrL1_Grl_	TrL1**	Trip command of the function in phase L1*
TOV59_StL2_Grl_	StL2	Starting of the function in phase L2*
TOV59_TrL2_Grl_	TrL2**	Trip command of the function in phase L2*
TOV59_StL3_Grl_	StL3	Starting of the function in phase L3*
TOV59_TrL3_Grl_	TrL3**	Trip command of the function in phase L3*

*In case of phase-to-phase voltages, these are changed to L12, L23, L31 respectively.

**The trip signals are not published for the phases individually

Table 1-7 The binary input signals of the definite time overvoltage protection function

Boolean parameter

Parameter name	Title	Default
Enabling start signal only:		
TOV59_StOnly_BPar_	Start Signal Only	FALSE

Table 1-8 The Boolean parameter of the definite time overvoltage protection function

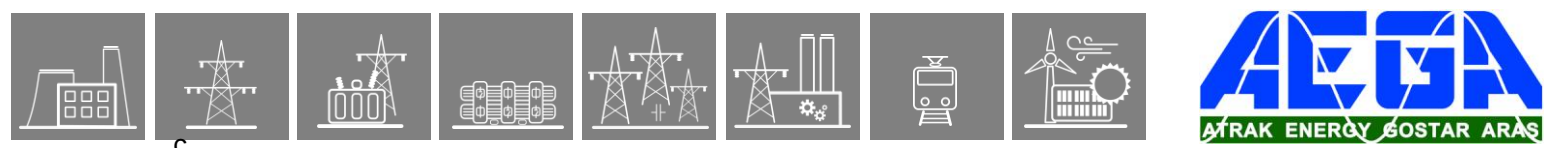

C

Binary status signals

The overvoltage protection function has a binary input signal, which serves the purpose of disabling the function. The conditions of disabling are defined by the user, applying the graphic equation editor.

Binary input status signal	Explanation
TOV59_BlK_GrO_	Output status of a graphic equation defined by the user to disable the definite time overvoltage protection function.

Table 1-9 The binary input signal of the definite time overvoltage protection function

Binary output status signal	Title	Explanation
TOV59_StL1_Grl_	StL1	Start in phase L1*
TOV59_StL2_Grl_	StL2	Start in phase L2*
TOV59_StL3_Grl_	StL3	Start in phase L3*
TOV59_GenSt_Grl_	GenSt	General start signal
TOV59_GenTr_Grl_	GenTr	General trip command

*In case of phase-to-phase voltages, these are changed to L12, L23, L31 respectively.

Table 1-10 The binary output status signals of the definite time overvoltage protection function

C

4.1.17.8. Technical summary

4.1.17.8.1. Technical data

Function	Value	Accuracy
Pick-up starting accuracy		< ± 0,5 %
Reset time U> → Un U> → 0	60 ms 50 ms	
Operate time accuracy		< ± 20 ms
Minimum operate time	50 ms	

Table 1-11 Technical data of the overvoltage protection function

4.1.17.8.2. Parameters

The parameters are summarized in Chapter 1.6 [Table 1-1](#), [Table 1-2](#), [Table 1-3](#), [Table 1-4](#), [Table 1-5](#).

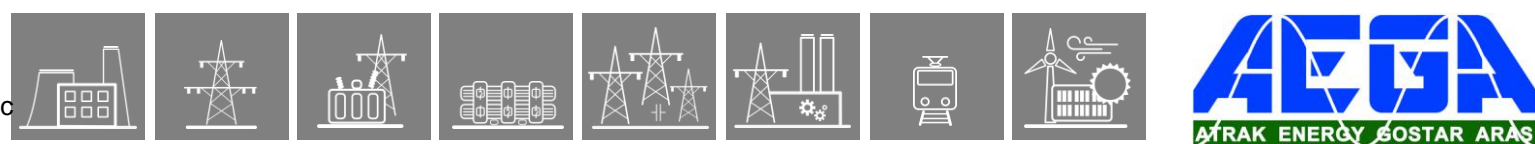

4.1.17.8.3. Binary output status signals

The **binary output status signals** of overvoltage protection function are listed in [Table 1-12](#)
 The binary output status signals of the overvoltage protection function

Binary status signal	Title	Explanation
TOV59_StL1_Grl_	StL1	Start in phase L1
TOV59_StL2_Grl_	StL2	Start in phase L2
TOV59_StL3_Grl_	StL3	Start in phase L3
TOV59_GenSt_Grl_	GenSt	General start signal
TOV59_GenTr_Grl_	GenTr	General trip command

Table 1-12 The binary output status signals of the overvoltage protection function

4.1.17.8.4. Binary input status signals

Binary input signals

The overvoltage protection function has a binary input signal, which serves the purpose of disabling the function. **The conditions of disabling are defined by the user, applying the graphic equation editor.**

Binary status signal	Title	Explanation
TOV59_BlK_GrO_	Blk	Blocking of the overvoltage protection function

Table 1-13 The binary input signal of the overvoltage protection function

4.1.17.8.5. The function block

The function block of the overvoltage protection function is shown in [Figure 1-6](#). This block shows all binary input and output status signals that are applicable in the graphic equation editor.

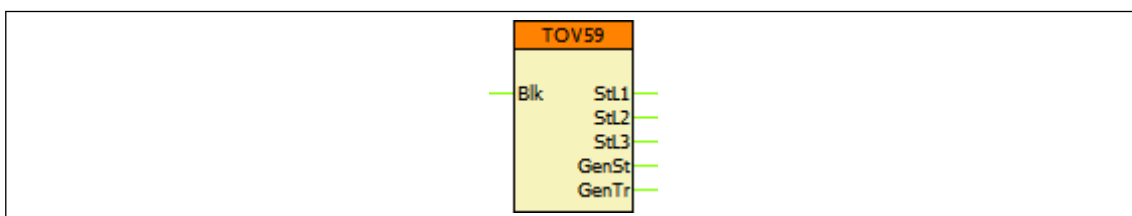

Figure 1-6 The function block of the overvoltage protection function

C

4.1.18. Residual definite time overvoltage protection function

The residual definite time overvoltage protection function operates according to definite time characteristics, using the RMS values of the fundamental Fourier component of the zero sequence voltage ($U_N=3U_0$).

4.1.18.1. Operating characteristics

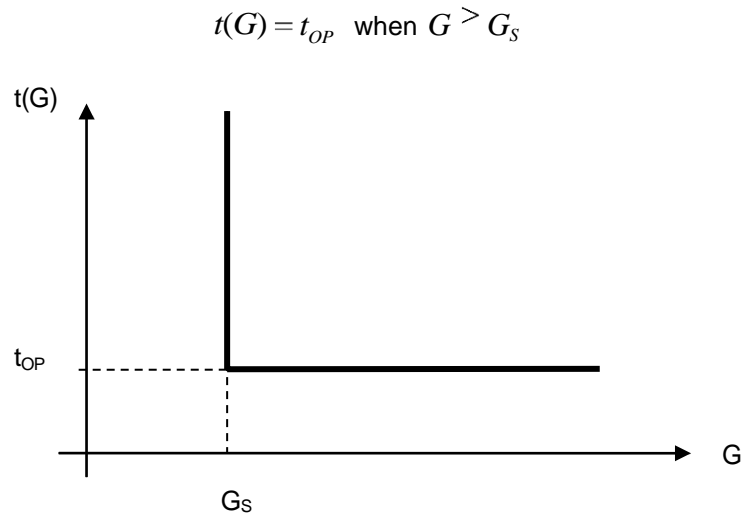

Figure I-1 Overvoltage independent time characteristic

Where

t_{OP} (seconds)	theoretical operating time if $G > G_S$, fix, according to the parameter setting value,
G	measured value of the characteristic quantity, Fourier base harmonic of the phase voltages,
G_S	setting value of the characteristic quantity (TOV59N_StCurr_IPar_, Start voltage).

C

4.1.18.2. Structure of the residual definite time overvoltage protection algorithm

Fig.1-2 shows the structure of the residual definite time overvoltage protection (TOV59N) algorithm.

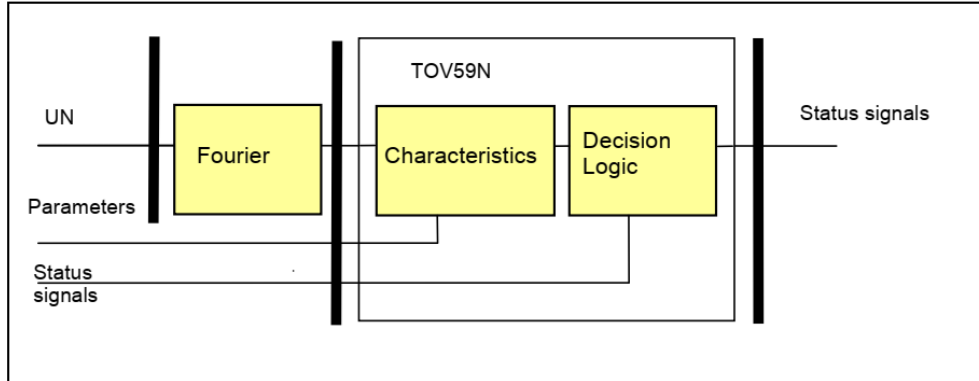

Figure 1-2 Structure of the definite time residual overvoltage protection algorithm

The **inputs** are

- the RMS values of the fundamental Fourier component of the residual or neutral voltage ($U_N=3U_0$),
- parameters,
- status signals.

The **outputs** are

- the binary output status signals.

The **software modules** of the differential protection function:

Fourier calculations

These modules calculate the basic Fourier components of the residual voltage (not part of the TOV59 function).

Characteristics

This module calculates the required time delay based on the Fourier components of the residual voltage.

Decision logic

The decision logic module combines the status signals to generate the trip command of the function.

The following description explains the details of the individual components.

C

4.1.18.3. The Fourier calculation (Fourier)

This module calculates the RMS value of the fundamental Fourier component of the residual or neutral voltage ($UN=3U_0$). This module is not part of the TOV59N function; it belongs to the preparatory phase.

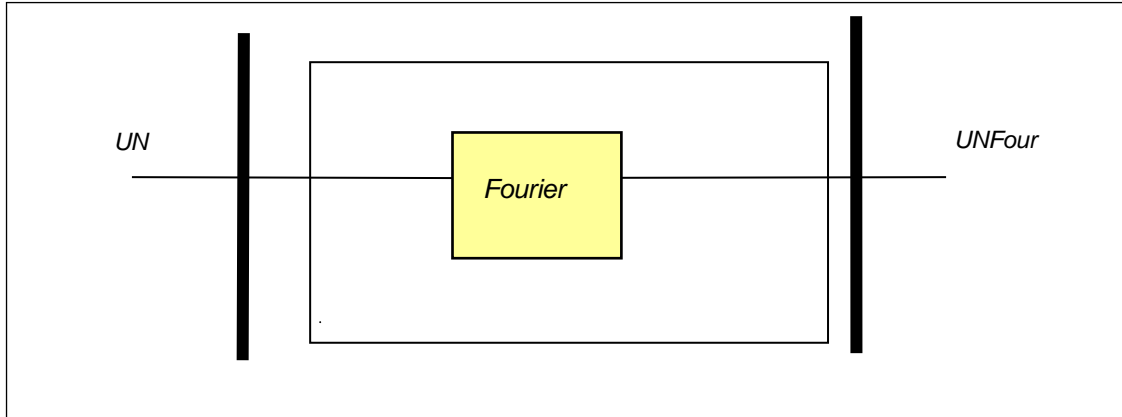

Figure 1-3 Schema of the Fourier calculation

The **input** is the sampled value of the residual voltage ($UN=3U_0$).

The **output** is the RMS value of the fundamental Fourier component of the residual or neutral voltage ($UNFour$).

4.1.18.4. The definite time characteristics (Characteristics)

This module decides the starting of the function and counts the required time delay based on the Fourier components of the residual voltage. The time delay is defined by the parameter setting value, if the voltage is above the voltage setting value.

The **inputs** are:

- the RMS value of the fundamental Fourier component of the residual or neutral voltage ($UNFour$),
- parameters.

The **outputs** are the status signals of the function. These indicate the started state of the function.

C

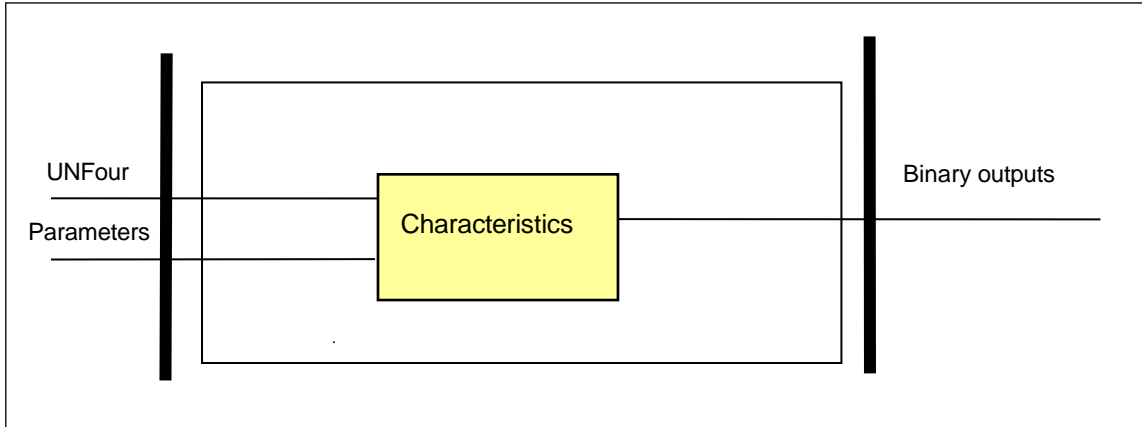

Figure 1-4 Schema of the residual definite time characteristic calculation

Enumerated parameter

Parameter name	Title	Selection range	Default
Parameter for enabling/disabling the function			
TOV59N_Oper_EPar_	Operation	Off, On	On

Table 1-1 The enumerated parameters of the residual definite time overvoltage protection function

Integer parameter

Parameter name	Title	Unit	Min	Max	Step	Default
Starting voltage parameter:						
TOV59N_StVol_IPar_	Start Voltage	%	2	60	1	30

Table 1-2 The integer parameters of the residual definite time overvoltage protection function

Timer parameter

Parameter name	Title	Unit	Min	Max	Step	Default
Definite time delay:						
TOV59N_Delay_TPar_	Time Delay	msec	0	60000	1	100

Table 1-3 Timer parameter of the residual definite time overvoltage protection function

The **binary output status signals** of the residual definite time overvoltage protection function are listed in Table 1-4.

Binary output signals	Signal title	Explanation
TOV59N_St_GrI_	Start L1	Starting of the function
TOV59N_Tr_GrI_	Trip L1	Trip command of the function

Table 1-4 The binary output status signals of the residual definite time overvoltage protection function

4.1.18.5. The decision logic (Decision logic)

The decision logic module combines the status signals, binary and enumerated parameters to generate the trip command of the function.

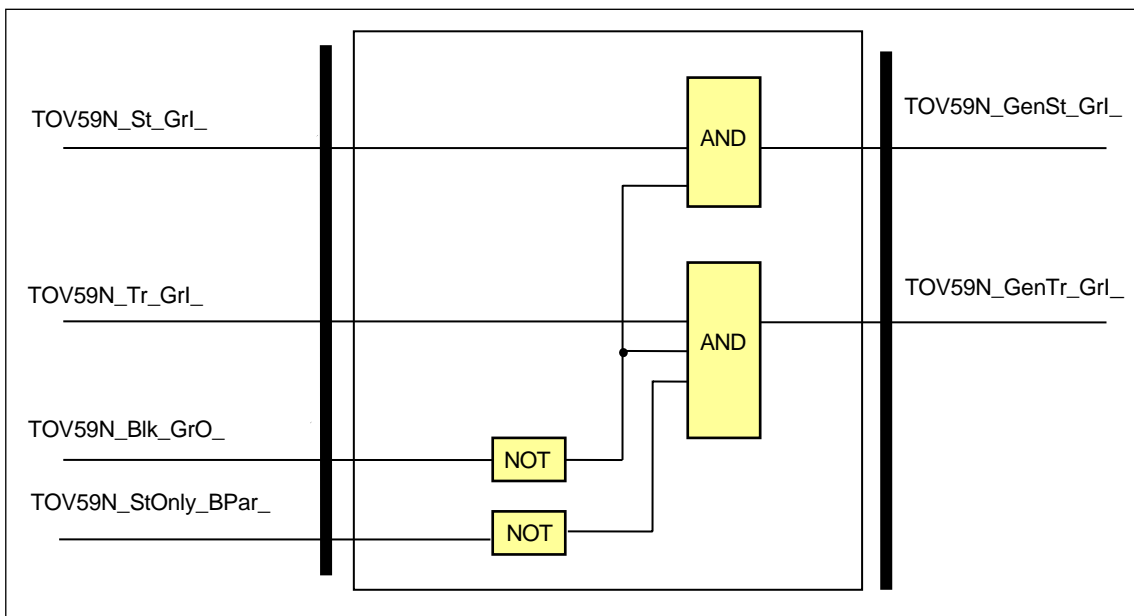

Figure 1-5 The logic scheme of the residual definite time overvoltage protection function

Binary input signals	Signal title	Explanation
TOV59N_St_GrI_	Start L1	Starting of the function
TOV59N_Tr_GrI_	Trip L1	Trip command of the function

Table 1-5 The binary input status signals of the decision logic scheme for the residual definite time overvoltage protection function

Boolean parameter

Parameter name	Title	Default
Enabling start signal only:		
TOV59N_StOnly_BPar_	Start Signal Only	FALSE

Table 1-6 The Boolean parameter of the residual definite time overvoltage protection function

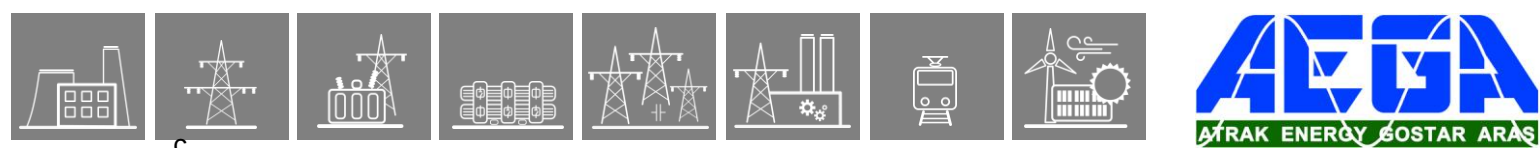

C

Binary status signals

The overvoltage protection function has a binary input signal, which serves the purpose of disabling the function. **The conditions of disabling are defined by the user, applying the graphic equation editor.**

Binary status signal	Explanation
TOV59N_Blk_GrO_	Output status of a graphic equation defined by the user to disable the residual definite time overvoltage protection function.

Table 1-7 The binary input signal of the residual definite time overvoltage protection function

Binary output signals	Signal title	Explanation
TOV59N_GenSt_Grl_	General Start	General starting of the function
TOV59N_GenTr_Grl_	General Trip	General trip command of the function

Table 1-8 The binary output status signals of the residual definite time overvoltage protection function

4.1.18.6. Technical summary

4.1.18.6.1. Technical data

Function	Value	Accuracy
Pick-up starting accuracy	2 – 8 % 8 – 60 %	< ± 2 % < ± 1.5 %
Reset time U> → Un U> → 0	60 ms 50 ms	
Operate time	50 ms	< ± 20 ms

Table 1-9 Technical data of the residual definite time overvoltage protection function

4.1.18.6.2. The parameters

The parameters are summarized in Chapters 1.4 and 1.5.

4.1.18.6.3. The binary output status signals

The **binary output status signals** of the residual definite time overvoltage protection function are listed in Table 1-10.

Binary output signals	Signal title	Explanation
TOV59N_GenSt_Grl_	General Start	General starting of the function
TOV59_N_GenTr_Grl_	General Trip	General trip command of the function

Table 1-10 The binary output status signals of the residual definite time overvoltage protection function

4.1.18.6.4. The binary input status signals

The residual definite time overvoltage protection function has a binary input signal, which serves the purpose of disabling the function. **The conditions of disabling are defined by the user, applying the graphic equation editor.**

Binary input signal	Explanation
TOV59N_Blkn_GrO_	Output status of a graphic equation defined by the user to disable the residual definite time overvoltage protection function.

Table 1-11 The binary input signal of the residual definite time overvoltage protection function

4.1.18.6.5. The function block

The function block of the residual overvoltage protection function is shown in Figure 1-6. This block shows all binary input and output status signals that are applicable in the graphic equation editor.

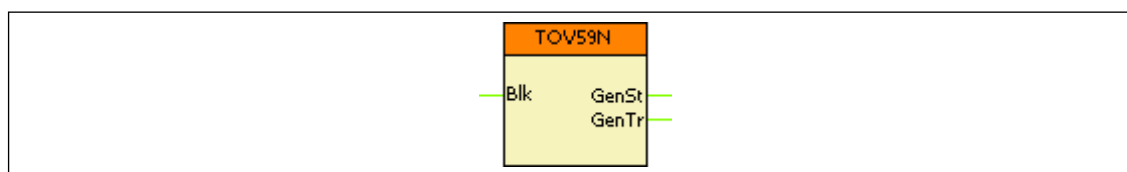
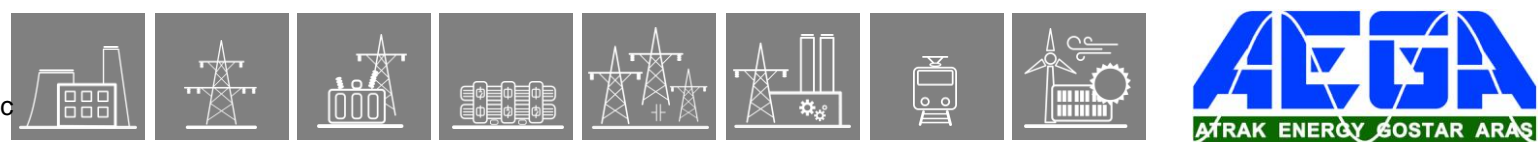

Figure 1-6 The function block of the residual overvoltage protection function



4.1.19. Directional three-phase overcurrent protection function

4.1.19.1. Application

The directional three-phase overcurrent protection function can be applied on solidly grounded, compensated or isolated networks, where the overcurrent protection must be supplemented with a directional decision.

The direction can be selected as forward or backward. The overcurrent decision can be set also without considering the decision.

The overcurrent decision can be based on current RMS values or on Fourier fundamental harmonic values.

The time overcurrent characteristic can be definite time or several types of standard IEC or ANSI characteristics.

4.1.19.1.1. Mode of operation

The inputs of the function are three-phase currents and voltages. For directional decision the Fourier basic harmonic components of the three phase currents and those of the three phase voltages are calculated. The Fourier fundamental components can be selected also for overcurrent decision. For this evaluation, the other choice is RMS values of the phase currents.

NOTE: The Fourier calculation and the RMS value calculation do not belong to the directional three-phase overcurrent protection function. The results of these calculation are applied by several other function blocks, configured in the device.

The directional decision is similar to a distance protection function decision: Based on the measured voltages and currents, from among the six loops (L1L2, L2L3, L3L1, L1N, L2N, L3N) the block selects the one with the smallest calculated loop impedance. Based on the loop voltage and loop current of the selected loop the directional decision generates a signal of TRUE value if the voltage and the current is sufficient for directional decision, and the angle difference between the vectors is within the setting range. This decision enables the output start and trip signal of an overcurrent protection function block, based on the selected current. If the voltages of the selected loop are not sufficient for the directional decision, then healthy phase voltages (positive sequence), or pre-fault voltages stored in the memory are also applied.

The function generates a trip command if both the direction (if this choice is selected) and the current magnitude satisfy the requirements as set by parameters, and also the time delay defined by the selected characteristic has expired.

The operating characteristics meet the requirements of IEC 60255-151.

The function is influenced by input binary signals:

- The function can be blocked by “Blk” input
- The signal from the voltage transformer supervision circuit indicates that the voltage signals are not available. “VTS” input. If this input is active, then the directional operation is disabled.
- If the circuit breaker closes in case of close-up fault, then the voltage is not suitable for directional decision. To let the directional overcurrent function operate in case of this “switch-onto-fault” case, the binary input “SOTFCondition” is used. If this input is active then the function operates without directional decision and with high speed.

NOTE: the input signals are assigned by the user, using the logic editor in the EuroCAP configuration software tool.

4.1.19.1.2. Structure of the three-phase directional overcurrent protection algorithm

Figure 1-1 shows the structure of the three-phase directional overcurrent protection (TOC67) algorithm.

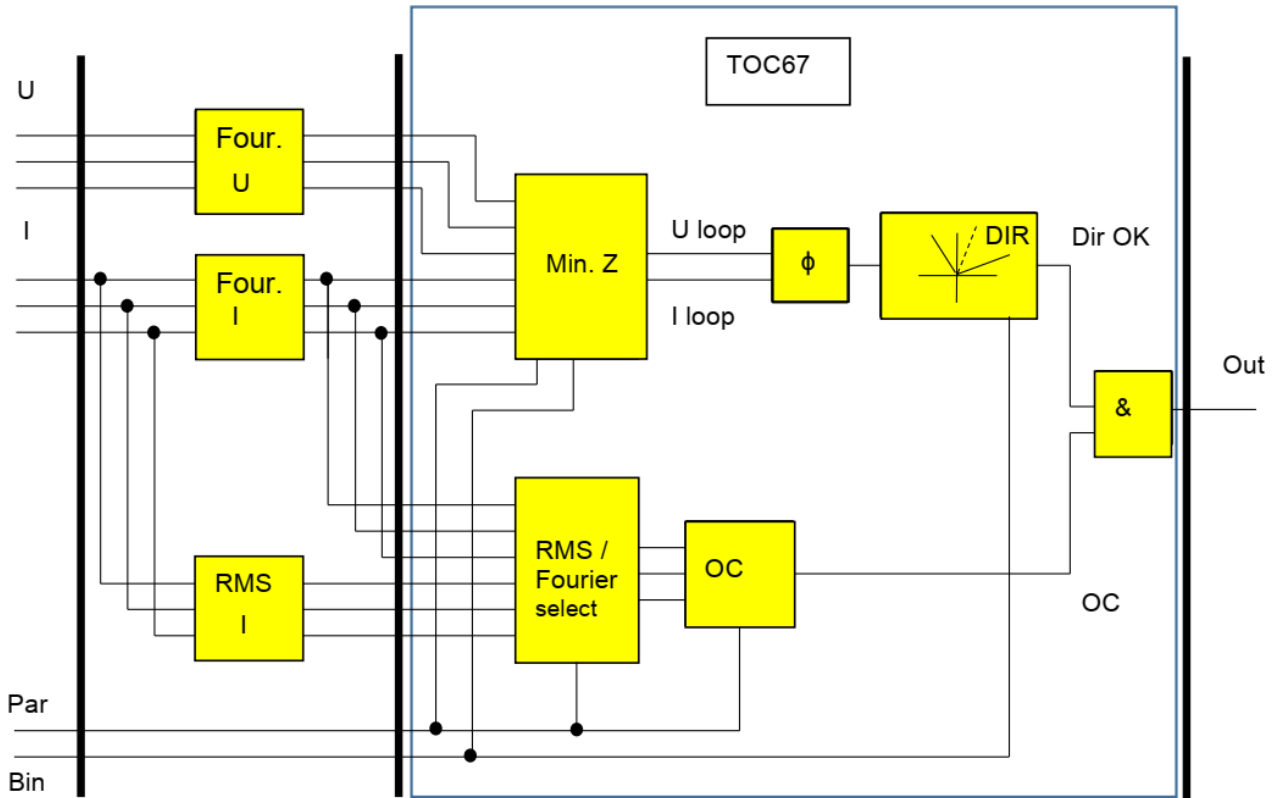

Figure 1-1 Structure of the three-phase directional overcurrent protection algorithm

The **inputs** are

- the RMS value of the three phase currents (IL1, IL2, IL3). NOTE: The RMS calculation is not part of the directional overcurrent function, it is performed by an external function block.
- the RMS value of the fundamental Fourier component of the three phase currents (IL1, IL2, IL3). NOTE: The Fourier calculation is not part of the directional overcurrent function, it is performed by an external function block.
- the RMS value of the fundamental Fourier component of the three phase voltages (UL1, UL2, UL3). NOTE: The Fourier calculation is not part of the directional overcurrent function, it is performed by an external function block.
- the RMS value of the fundamental Fourier component of the three phase-to-phase voltages (UL1L2, UL2L3, UL3L1). NOTE: The phase-to-phase voltage calculation is not part of the directional overcurrent function, it is performed by an external function block.
- parameters,
- binary status signals.

The function can be enabled or disabled by a parameter. The status signal of the VTS (voltage transformer supervision) function can also disable the directional operation.

The **outputs** are

- the binary output status signals (Start L1, Start L2, Start L3, General start, Trip).

input of the function block by the user, using the logic editor function of the EuroCAP configuration software. The effect of this signal is decided by the Boolean parameter “NonDir when VTS”: if this parameter is logic TRUE (checked) then the evaluation for “Forward” or “Backward” turns automatically to “NonDir”, the output signal depend on the magnitude of the current only. If the “NonDir when VTS” Boolean parameter is not checked, then the TRUE state of the “VTS” binary input blocks the operation of the function block. The related parameter is shown in Table 1-2.

The **internal output signal** is the decision of the direction function. If the direction is OK, the output signal is TRUE, i.e. the phase angle between the three-phase voltage and the three-phase current is within the limit range, defined by the preset parameter OR non-directional operation is selected by the preset parameter TOC67_Dir_EPar_ (Direction=NonDir).

This block generates a TRUE internal status signal also for SOTF condition, and when no directional decision is required by parameter setting.

Table 1-2 The boolean parameter of the directional decision

Parameter name	Title	Selection range	Default
Turn the function to non-directional mode or block the function if the “VTS” binary input gets active			
TOC67_NDirVTS _BPar_	NonDir when VTS	Checked, Not checked	Not checked

Table 1-3 The enumerated parameter of the directional decision

Parameter name	Title	Selection range	Default
Directionality of the function			
TOC67_Dir_EPar_	Direction	NonDir, Forward, Backward	Forward

Table 1-4 The integer parameters of the directional decision

Parameter name	Title	Unit	Min	Max	Step	Default
Operating angle (See Figure 1-2)						
TOC67_ROA_IPar_	Operating Angle	deg	10	85	1	60
Characteristic angle (See Figure 1-2)						
TOC67_RCA_IPar_	Characteristic Angle	deg	-90	90	1	60

4.1.19.1.2.4. RMS or Fourier selection (RMS/Fourier select)

This module selects RMS or Fourier values as inputs for overcurrent module.

Table 1-5 The enumerated parameter of the input type selection

Parameter name	Title	Selection range	Default
RMS or Fourier selection			
TOC67_InputType_EPar_	Input Type	Fundamental, RMS	Fundamental

4.1.19.1.2.5. The overcurrent protection function (OC)

This module is equivalent to the TOC51 (three-phase (non-directional) overcurrent) function block described in a separate document. The additional input binary signal enables the operation if the directional decision module generates a logic TRUE value, indicating that the phase angle is in the range defined by the preset parameter or that non-directional decision is required.

4.1.19.1.2.5.1. Operating characteristics

4.1.19.1.2.5.2. Independent time characteristic

$$t(G) = t_{OP} \text{ when } G > G_s$$

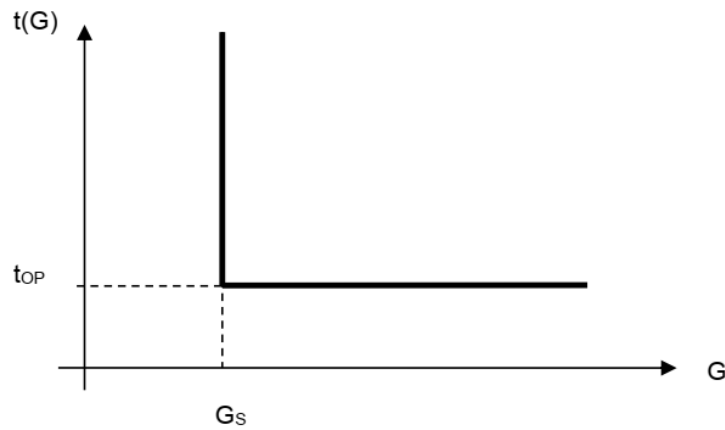

Figure 1-3 Overcurrent independent time characteristic

where

- t_{OP} (seconds) theoretical operating time if $G > G_s$, fix, according to the preset parameter,
- G measured value of the characteristic quantity, Fourier base harmonic of the phase currents,
- G_s preset value of the characteristic quantity (“Start current” parameter).

Structure of the overcurrent protection algorithm

Fig.1-4 shows the structure of the overcurrent protection (OC) algorithm.

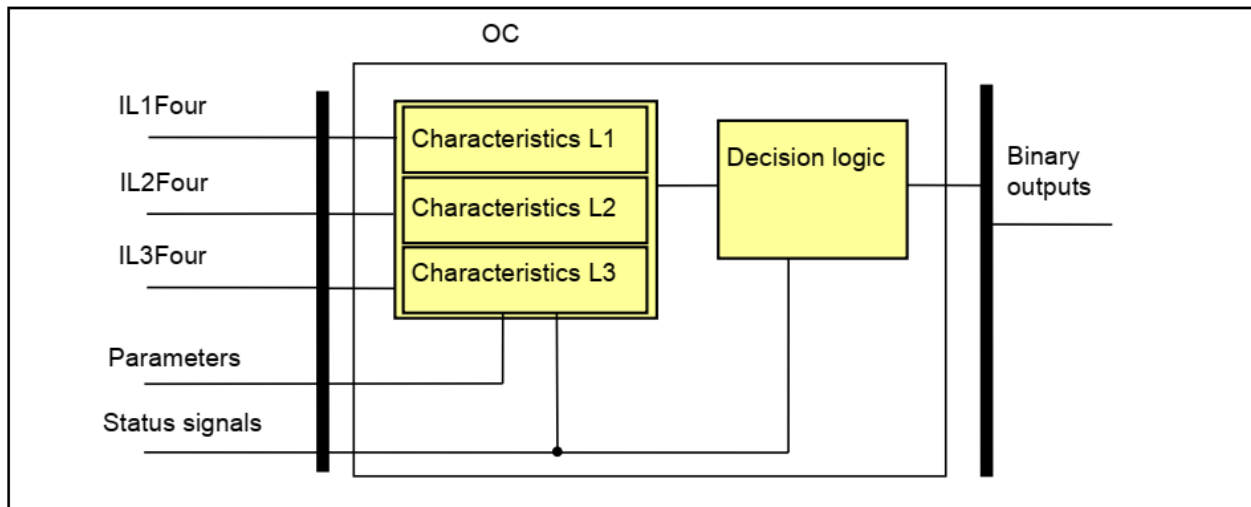

Figure 1-4 Structure of the overcurrent protection algorithm

The **inputs** are

- the RMS value of the fundamental Fourier component of three phase currents,
- parameters,
- status signals.

The **outputs** are

- the binary output status signals.

The **software modules** of the overcurrent protection function:

Characteristics

This module calculates the required time delay based on the Fourier components of the phase currents.

Decision logic

The decision logic module combines the status signals to generate the trip command of the function.

The following description explains the details of the individual components.

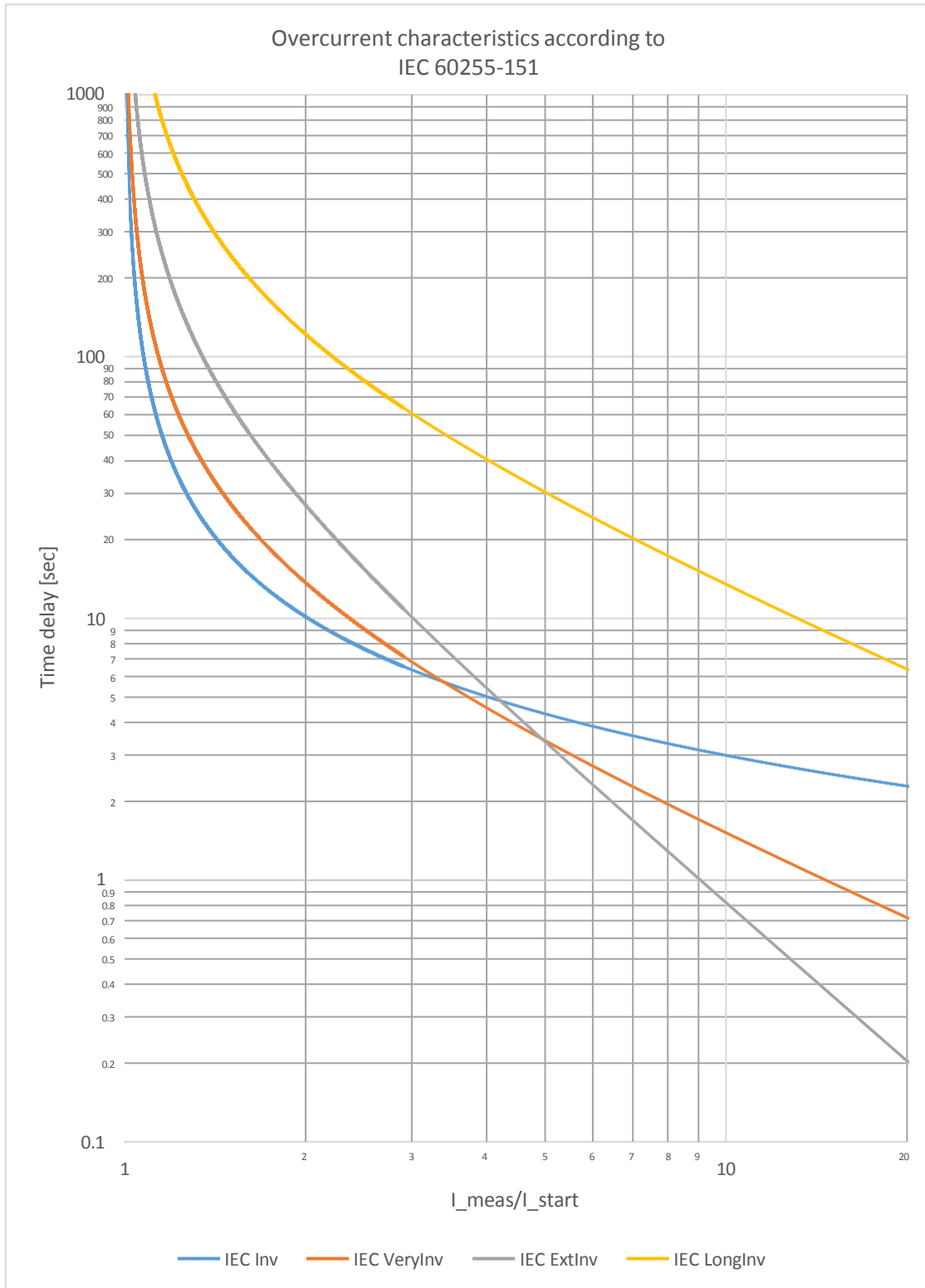

Figure 1-6 Overcurrent characteristics according to IEC 60255-151

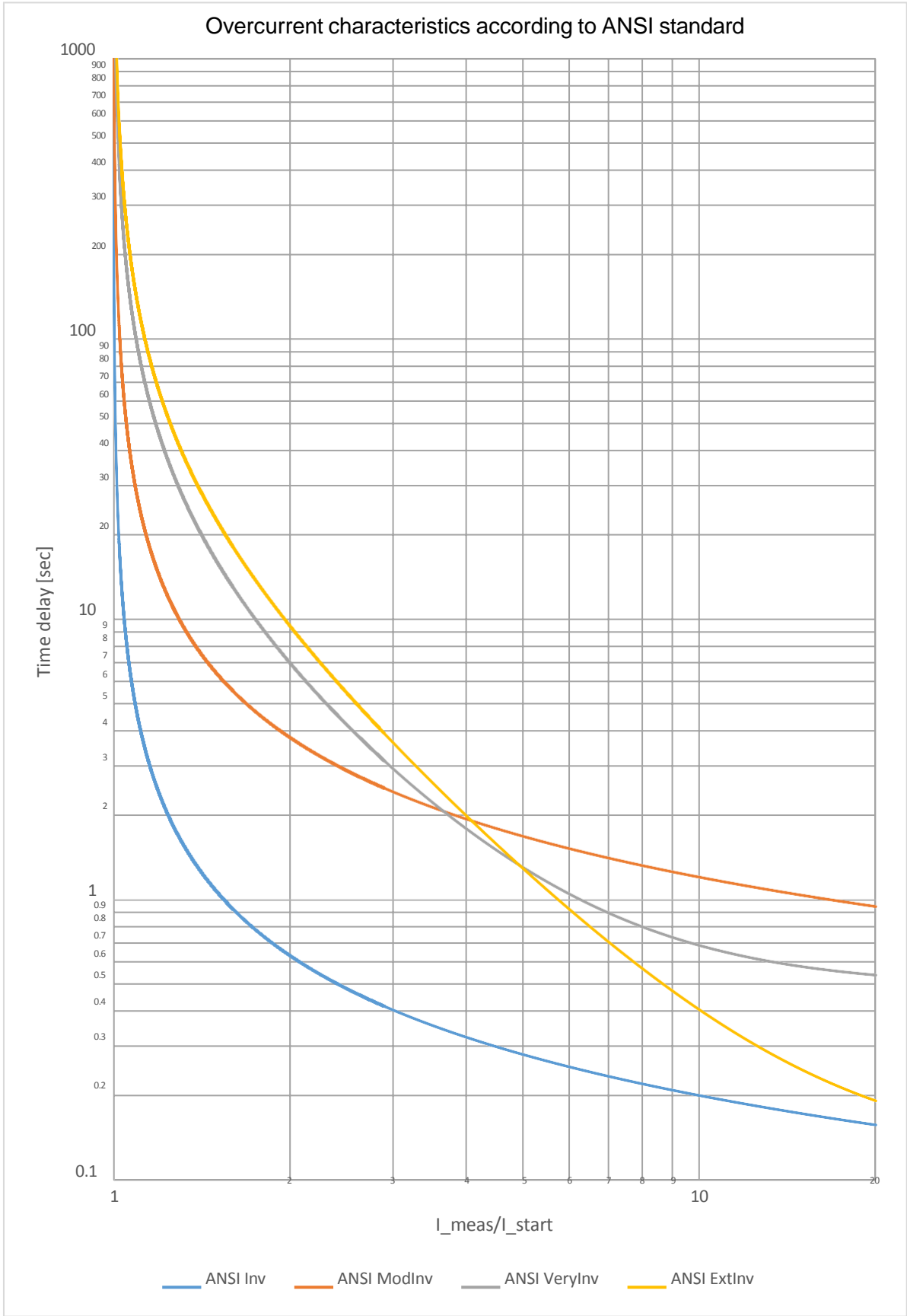

Figure 1-7 Overcurrent characteristics according to ANSI standard

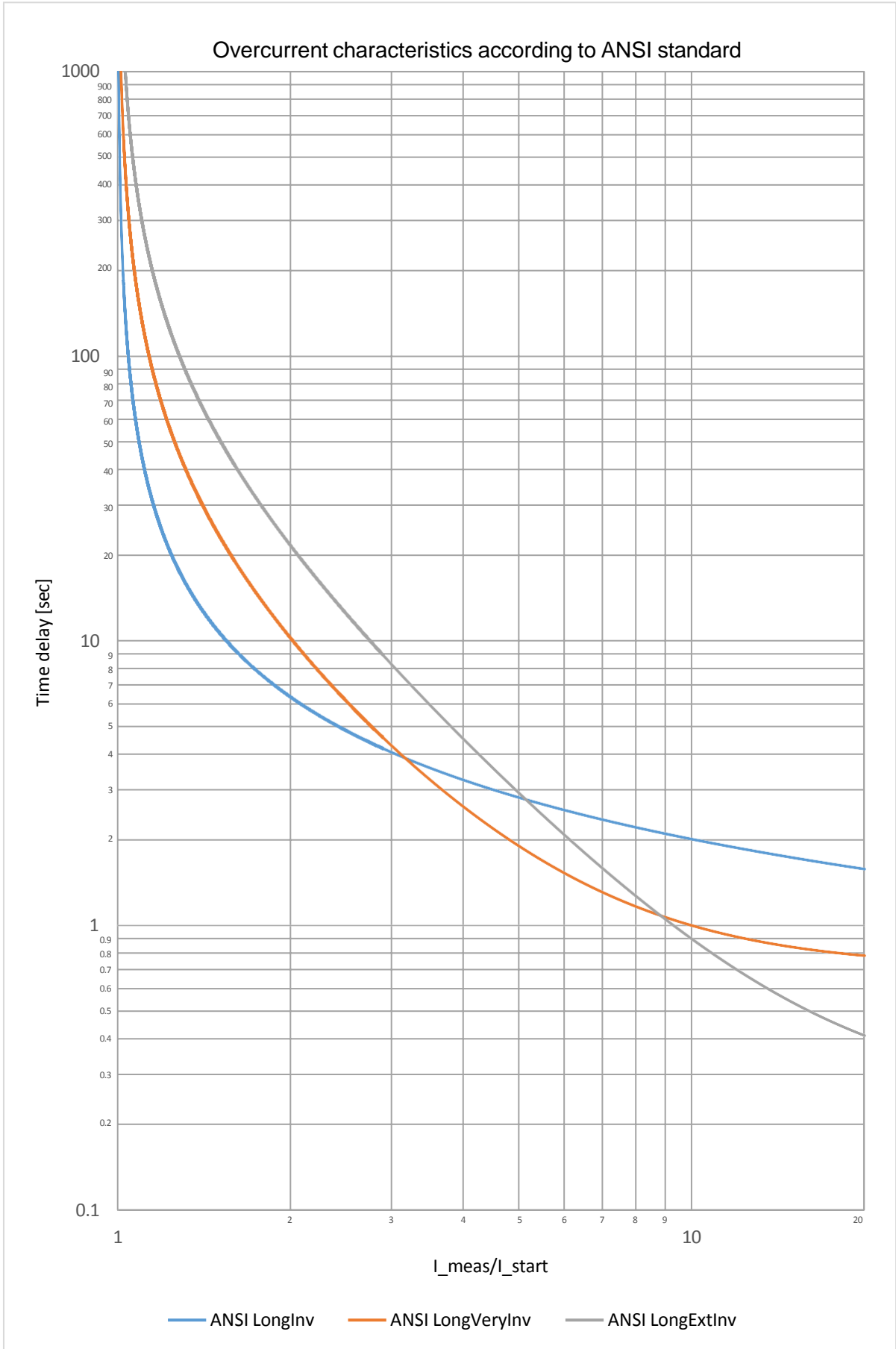

Figure 1-8 Overcurrent characteristics according to ANSI standard

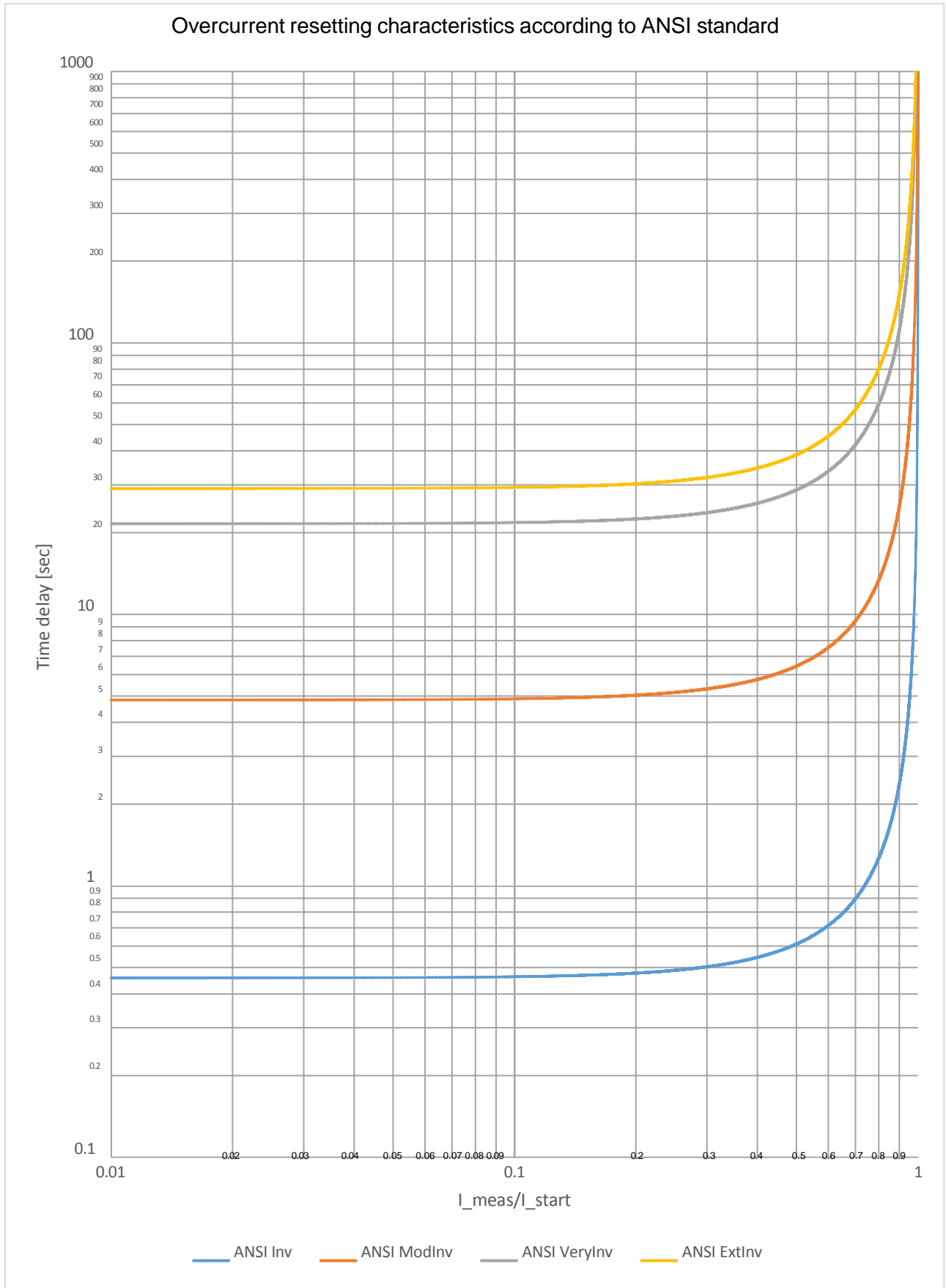

Figure 1-9 Overcurrent resetting characteristics according to ANSI standard

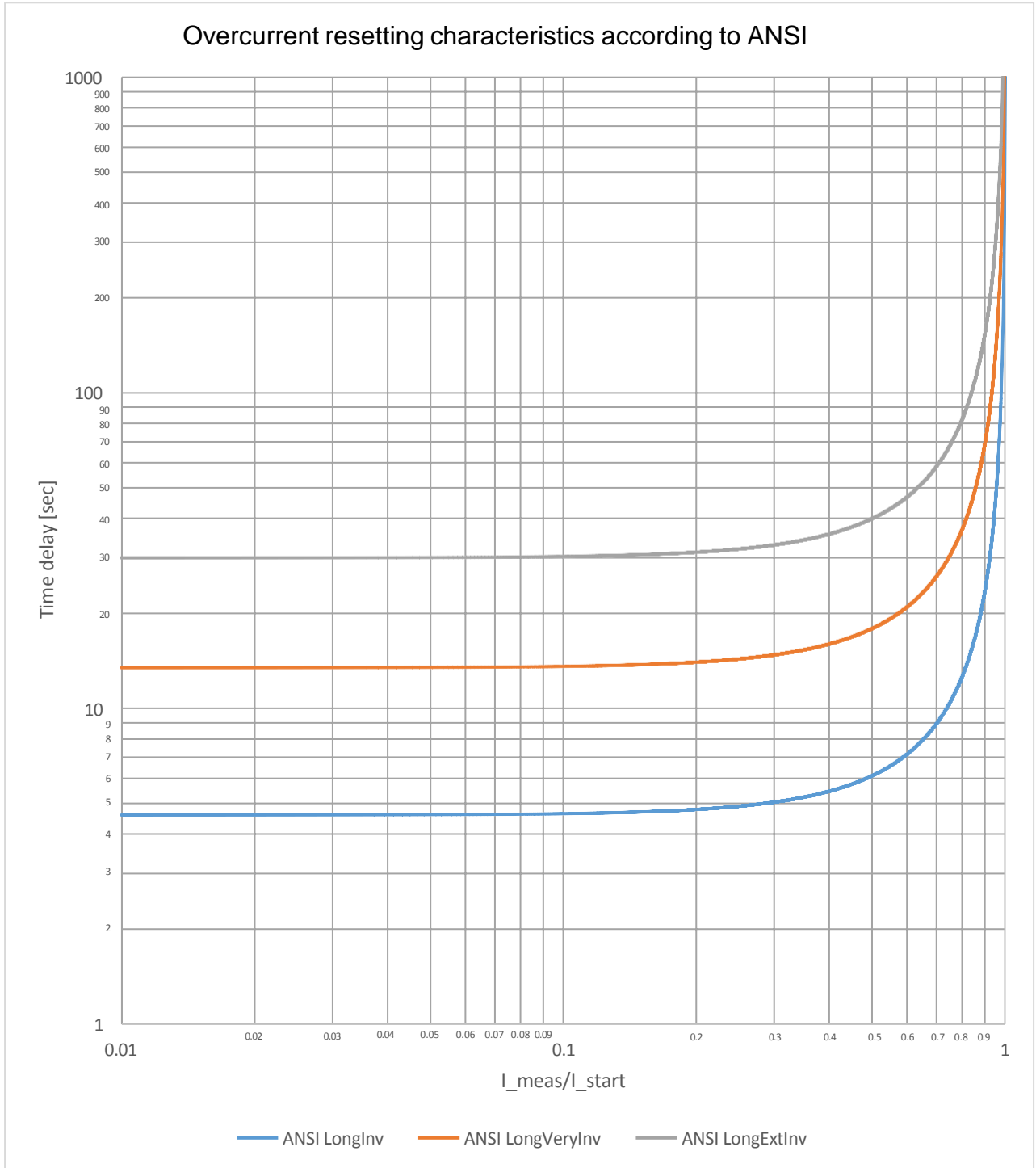

Figure 1-10 Overcurrent resetting characteristics according to ANSI standard

4.1.19.2. 3ph Dir Overcurrent function overview

The function block of the three-phase directional overcurrent protection function is shown in Figure 2-1. This block shows all binary input and output status signals that are applicable in the graphic equation editor.

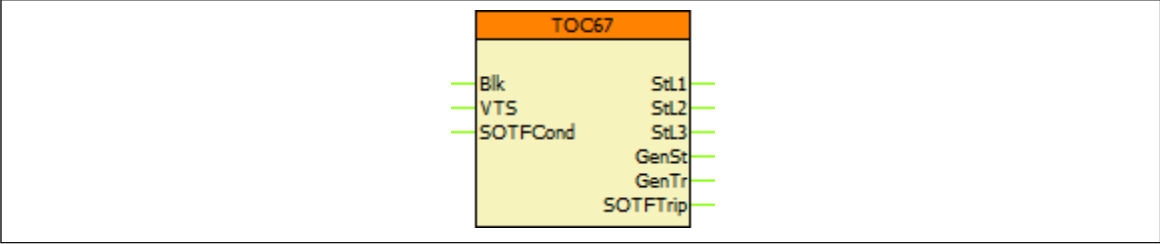

Figure. 2-1 The function block of the three-phase overcurrent function

4.1.19.3. Settings

4.1.19.3.1. Parameters

The available parameters are listed below in order of their appearance in the *parameters* menu. If the setting range of a parameter should be extended, contact Protecta Support.

Table 2-1 The available parameters of the harmonics function

TITLE	DIM.	RANGE	STEP	DEFAULT	EXPLANATION
Operation	-	Off, Definite Time, IEC Inv, IEC VeryInv, IEC ExtInv, IEC LongInv, ANSI Inv, ANSI ModInv, ANSI VeryInv, ANSI ExtInv, ANSI LongInv, ANSI LongVeryInv, ANSI LongExtInv	-	Off	Enabling the function by choosing the characteristics.
Network type	-	Solidly Earthed, Isolated	-	Solidly Earthed	
Measurement method	-	Fundamental, RMS	-	Fundamental	<i>Fundamental</i> method is suitable for general overcurrent applications. <i>RMS</i> method is needed thermal-based applications – this method takes the entire current (all harmonics) into consideration at the cost of accuracy.
Direction	-	Non-directional, Forward, Backward	-	Forward	<i>Non-directional</i> makes the function operate as a basic TOC51 function.
Non-Directional – VT Fail	-	FALSE, TRUE	-	FALSE	When checked, the VT failure signal does not block the function but switches it to non-directional mode instead.
Operating Angle	deg	10 – 85	1	60	Relay Operating Angle. The angle at which the characteristic is extended in both directions from the Characteristic angle (e.g. a setting of 60 degrees will result in 120 degrees wide characteristics).
Characteristic Angle	deg	-90 – 90	1	60	The angle from which the Operating angle parameter defines the characteristics.
Start Current	%	10 – 4000	1	200	Starting current of the function
Time Multiplier		0.05 – 15.00	0.01	1.00	Time multiplier of the inverse characteristics
Min Time Delay	msec	30 – 60000	1	100	Minimal time delay for the inverse characteristics
Definite Time Delay	msec	30 – 60000	1	100	Time delay in case of definite time characteristic is selected
Reset Time	msec	60 – 60000	1	100	Reset time delay for the IEC inverse characteristics

4.1.19.4. Function I/O

This section describes briefly the analogue and digital inputs and outputs of the function block.

4.1.19.4.1. Analogue inputs

The function uses the Fourier values of the three-phase currents and of the calculated impedance loops. This is defined in the configuration.

4.1.19.4.2. Binary output signals (graphed input statuses)

The binary output status signals of the directional three-phase overcurrent protection function are listed in Table 2-2. **Parts** written in **bold** are seen on the function block in the logic editor.

Table 2-2 The binary output signals of the directional three-phase overcurrent function

BINARY OUTPUT SIGNALS	SIGNAL TITLE	EXPLANATION
TOC67_ StL1 _Grl_	Start L1	Starting of the function in phase L1
TOC67_ StL2 _Grl_	Start L2	Starting of the function in phase L2
TOC67_ StL3 _Grl_	Start L3	Starting of the function in phase L3
TOC67_ GenSt _Grl_	General Start	General start of the function
TOC67_ GenTr _Grl_	General Trip	General trip command of the function

4.1.19.4.3. Binary input signals (graphed output statuses)

The directional three-phase overcurrent protection function has binary input signals, which serve the purpose of disabling the function or its directional operation and determine the operation in case of switching on close-up fault. All statuses are defined by the user in the graphical Logic Editor.

Table 2-3 The binary input signals of the directional three-phase overcurrent function

BINARY INPUT SIGNALS	EXPLANATION
TOC67_ Blk _GrO_	Output status of a graphic equation to disable the function
TOC67_ VTS _GrO_	Usually connected to the voltage transformer supervision function or other VT failure signal, this input either blocks the function or makes it operate without directional decision, depending on the <i>Non-Directional - VT Fail</i> parameter
TOC67_ SOTFCond _GrO_	In case of switching on fault, this status makes the function to operate without directional decision and delay with high speed.

4.1.19.4.4. On-line data

Visible values on the on-line data page.

Table 2-4 On-line data of the directional three-phase overcurrent protection function

SIGNAL TITLE	DIMENSION	EXPLANATION
Start L1	-	Starting of the function in phase L1
Start L2	-	Starting of the function in phase L2
Start L3	-	Starting of the function in phase L3
General Start	-	General start of the function
General Trip	-	General trip command of the function



4.1.19.4.5. Events

The following events are generated in the event list, as well as sent to SCADA according to the configuration.

Table 2-5 Events of the three-phase overcurrent protection function

EVENT	VALUE	EXPLANATION
Start L1	off, on	Start of the directional three-phase overcurrent protection function in measuring element L1
Start L2	off, on	Start of the directional three-phase overcurrent protection function in measuring element L2
Start L3	off, on	Start of the directional three-phase overcurrent protection function in measuring element L3
Start	off, on	General start of the directional three-phase overcurrent protection function
Trip	off, on	General trip command of the directional three-phase overcurrent protection function

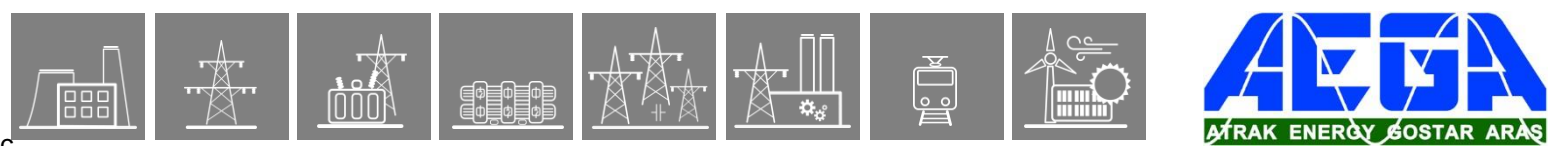

4.1.19.5. Technical data

Table 2-6 Technical data of the function

FUNCTION	VALUE	ACCURACY
Operating accuracy		<2 %
Operate time accuracy	If Time multiplier is >0.1	±5 % or ±35 ms, whichever is greater
Accuracy in minimum time range		±35 ms
Reset ratio	0,95	
Reset time Dependent time char. Definite time char.	Approx. 50 ms	<2% or ±35ms, whichever is greater
Transient overreach	2 %	
Pickup time with non-directional setting	25-30 ms	
Pickup time with directional setting	<100 ms	
Memory storage time span 50 Hz 60 Hz	80 ms 70 ms	±15 ms ±15 ms
Angular accuracy $I \leq 0.1 I_n$ $0.1 I_n < I \leq 0.4 I_n$ $0.4 I_n < I$		< ±10° < ±5° < ±2°
Angular reset	10°	

4.1.19.6. Notes for testing

There is an XRIO setting file available for the function (downloadable from the Protecta website). With that, only the parameters of the corresponding VT and CT modules and the 3ph Dir Overcurrent function should be entered along with the test current, when the characteristics are to be tested. By using this file, testing the operation characteristic will not need any further setting.

Normally in the EuroProt+ devices, the trip contacts are assigned to the Trip Logic function block, and not to the protection function blocks. Because of this, the testing personnel must make sure that the Trip Logic is switched on ('Operation' parameter is set to other than 'Off') before starting the testing, otherwise there will be no physical trip on the relay.

Note that the time delay parameter incorporates the algorithm time as well, so the time delay *does not mean the time difference between the appearance of the start and trip signals* of the function. In other words: it is not the delay between the detection of the fault and the trip that follows it. This should be taken into consideration when checking the disturbance records.

Instead, the time delay parameter defines the elapsed time from the appearance of the faulty state to the trip. Because of this, while testing, the delay measurement should start *from the moment of the fault injection* until the trip signal.

The reset time of the IDMT characteristics can be tested only indirectly by injecting the same fault currents again after a successful trip: if the time elapsed between the two injections is less than the reset time, the second injection will result in a quicker operation than the first.

The *angle reference of the setting is the current*, not the voltage, see Figure 1-2.

The 10° angular reset also means that if the prefault currents' angle is already in the characteristic, then the generated fault currents will still be considered as inside faults if their angle is less than 10° away from the borders.

Directionality (polarization) is based on the following measurements (numbers based on priority):

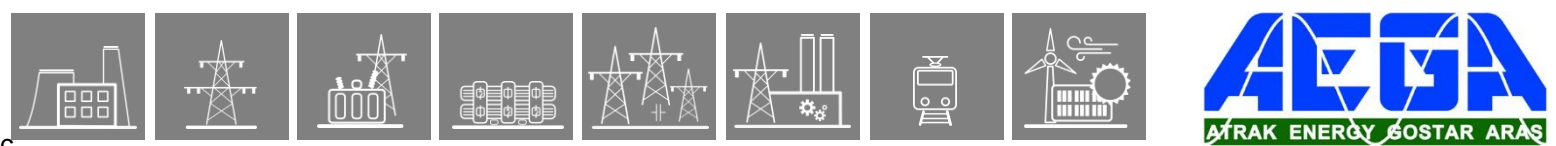

1. Voltage of the faulty phase (if present)

2. If the voltage is missing (e.g. 1ph fault), then the angle between the positive sequence current and positive sequence voltage is considered (only the angles, not the magnitudes)
3. If all voltages drop to 0, then the memory is used

4.1.19.7. Example for application

The example in this guide supposes that the device is connected to instrument transformers and to the circuit breakers according to *Figure 1-1*.

Busbar

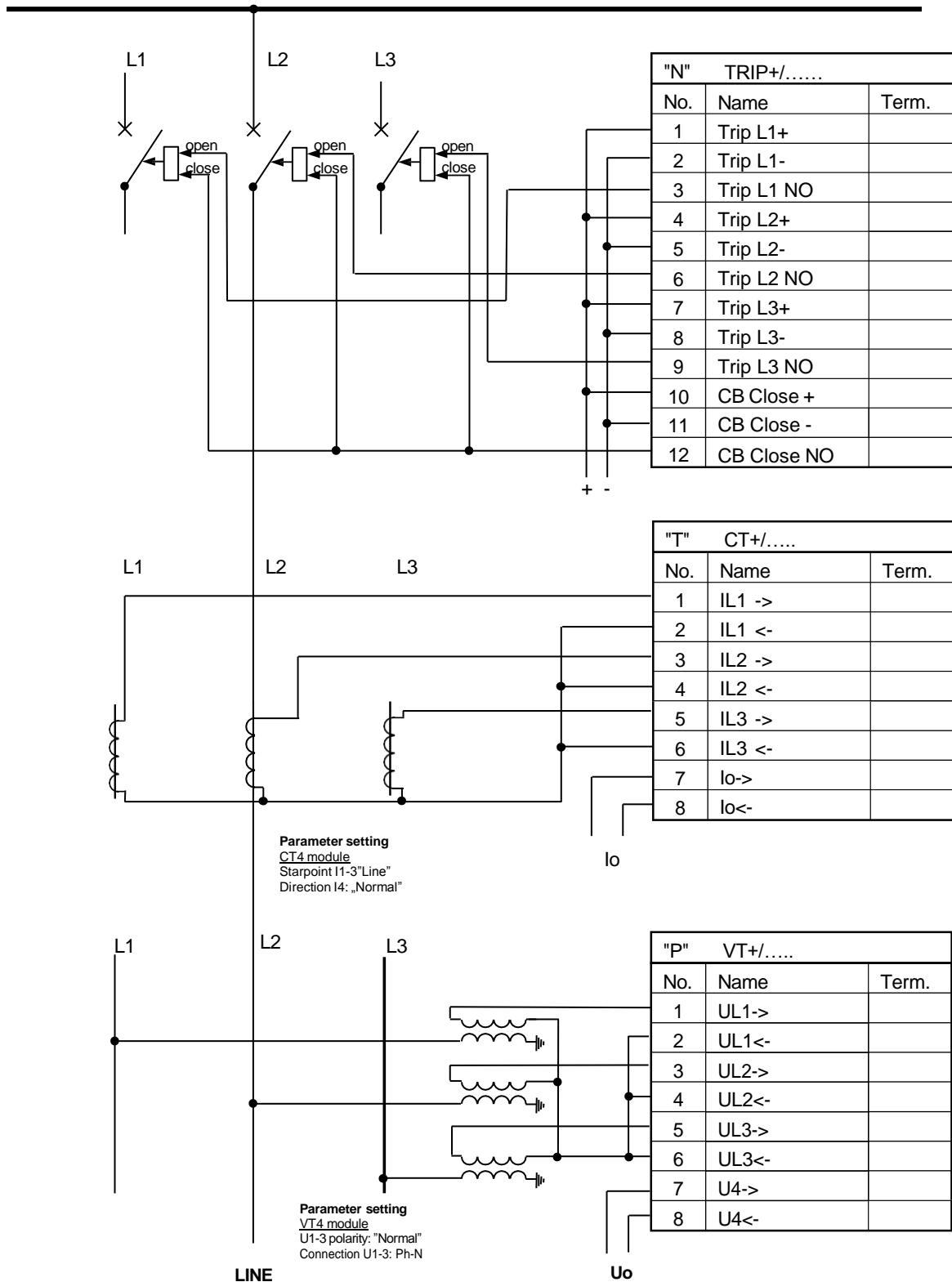

Figure 1-1 Connection example

The directional three-phase overcurrent protection function can be applied on solidly grounded networks, where the overcurrent protection must be supplemented with a directional decision. In these networks the fault is considered to be in “Forward” direction, if the measured fault impedance, using the positive directions shown in *Figure 1-2*, is inductive i.e. the calculated φ impedance angle is $0^\circ \leq \varphi \leq 90^\circ$.

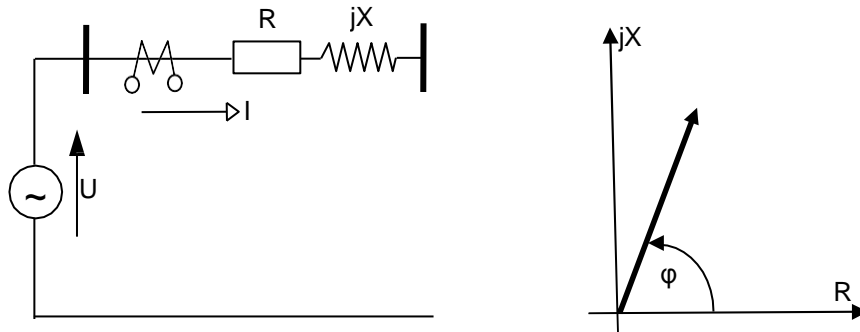

Figure 1-2 The fault impedance

The voltage and current vectors for this fault loop are shown in *Figure 1-3*.

In *Figure 1-3.a*), the voltage vector is the reference, the current lags relative to the voltage, the φ angle is negative. To change this angle to a positive value (as the value of the impedance angle is) the current is considered to be the reference. This is shown in *Figure 1-3.b*). The directional overcurrent protection function applies this coordinate system of *Figure 1-3.b*).

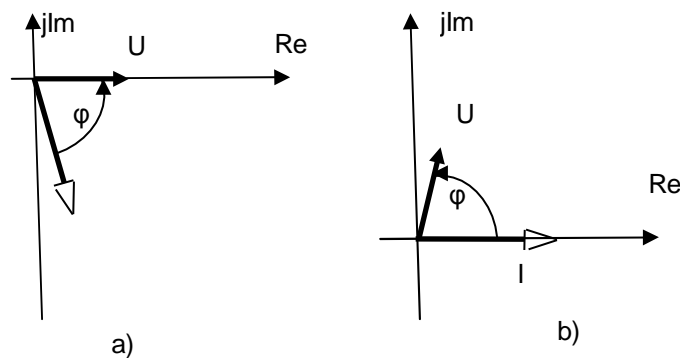

Figure 1-3 Voltage and current vectors in the faulty loop

Figure 1-4 below shows that the considered voltages are „loop” voltages and the considered currents are „loop” currents. The indicated operating range is valid if the “Direction” parameter is set “Forward”. If the direction parameter is set “Backward” then the operation range is mirrored to the origin of *Figure 1-4*. The setting “NonDir” for this parameter means that only the magnitude of the current is considered, the phase angles are neglected.

The „loop” voltages and the „loop” currents are selected according to the smallest loop impedance, depending on the detected fault type, according to Table 1-1.

C

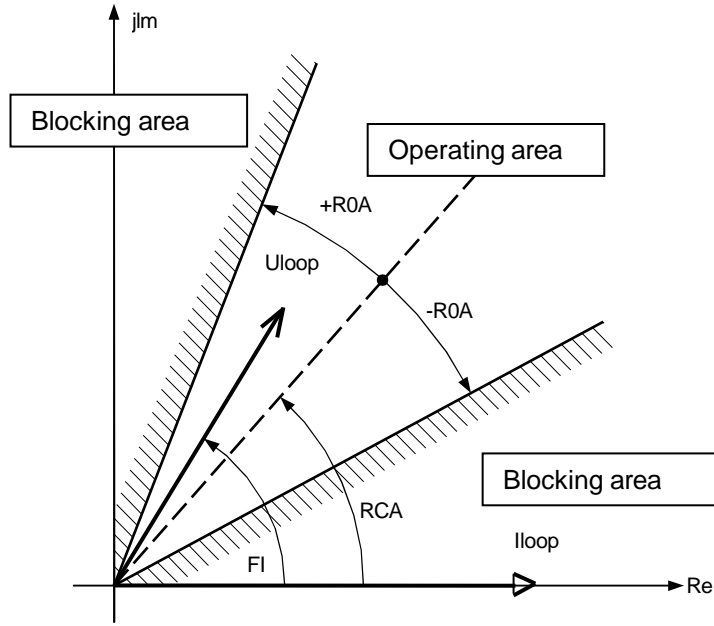

Figure 1-4 The directional decision

Based on the measured voltages and currents, from among the six loops (L1L2, L2L3, L3L1, L1N, L2N, L3N) the block selects the one with the smallest calculated loop impedance.

Fault	U_{loop}	I_{loop}
L1L2L3(N)	$U_{loop} = U_{L2} - U_{L3}$	$I_{loop} = I_{L2} - I_{L3}$
L1L2	$U_{loop} = U_{L1} - U_{L2}$	$I_{loop} = I_{L1} - I_{L2}$
L2L3	$U_{loop} = U_{L2} - U_{L3}$	$I_{loop} = I_{L2} - I_{L3}$
L3L1	$U_{loop} = U_{L3} - U_{L1}$	$I_{loop} = I_{L3} - I_{L1}$
L1L2N	$U_{loop} = U_{L1} - U_{L1}$	$I_{loop} = I_{L1} - I_{L2}$
L2L3N	$U_{loop} = U_{L2} - U_{L3}$	$I_{loop} = I_{L2} - I_{L3}$
L3L1N	$U_{loop} = U_{L3} - U_{L1}$	$I_{loop} = I_{L3} - I_{L1}$
L1N	$U_{loop} = U_{L1}$	$I_{loop} = I_{L1} + 3I_o K_N$
L2N	$U_{loop} = U_{L2}$	$I_{loop} = I_{L2} + 3I_o K_N$
L3N	$U_{loop} = U_{L3}$	$I_{loop} = I_{L3} + 3I_o K_N$

Table 1-1 Loop voltage and current selection

In Table 1-1 I_o is the zero sequence current component, and the zero sequence current compensation factor is:

$$K_N = \frac{Z_o - Z_1}{3Z_1} = \frac{1}{3} \left(\frac{Z_o}{Z_1} - 1 \right)$$

If the device configuration includes also the distance protection, then this value is set for the distance protection function block. If the distance protection function is not applied then

$$K_N = 1$$

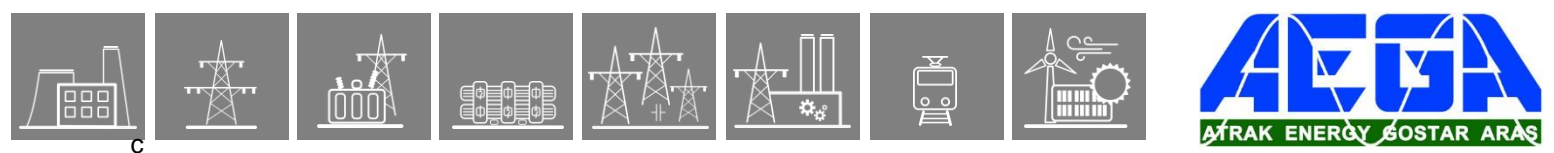

The function applies also the polarization method used for the distance protection:

- If the loop voltage is above 5% of the rated voltage input, then this loop voltage is applied for the decision.
- If the loop voltage is below 5% of the rated voltage input and there is healthy voltage available, then the healthy voltage is applied for the directional decision.
- If the loop voltage is below 5% of the rated voltage input and there is no healthy voltage available, then the voltage vectors stored in the memory are applied for the directional decision.
- If the loop voltage is below 5% of the rated voltage input and there is no healthy voltage available, and there are no voltage vectors stored in the memory then no decision is performed.

Based on the loop voltage and loop current of the selected loop the directional decision generates a signal of TRUE value if the voltage and the current is sufficient for directional decision, and the angle difference between the vectors is within the setting range. This decision enables the output start and trip signals of an overcurrent protection function block, based on the selected current.

The description above indicates that the basic concept of the directionality is the impedance angle, detected in the faulty loop.

4.1.20. Directional residual overcurrent protection function

4.1.20.1. Application

The main application area of the directional residual overcurrent protection function is the earth-fault protection.

4.1.20.2. Mode of operation

The inputs of the function are the Fourier basic harmonic components of the zero sequence current and those of the zero sequence voltage.

The block of the directional decision generates a signal of TRUE value if the $UN=3U_0$ zero sequence voltage and the $IN=-3I_0$ current are sufficient for directional decision, and the angle difference between the vectors is within the preset range. This decision enables the output start and trip signals of the residual overcurrent protection function block (TOC51N).

Note: the position of the vectors in *Figure 1-1* indicates a forward fault, i.e., the location of the earth fault is on the protected line (the positive direction of the current is from the busbar to the line).

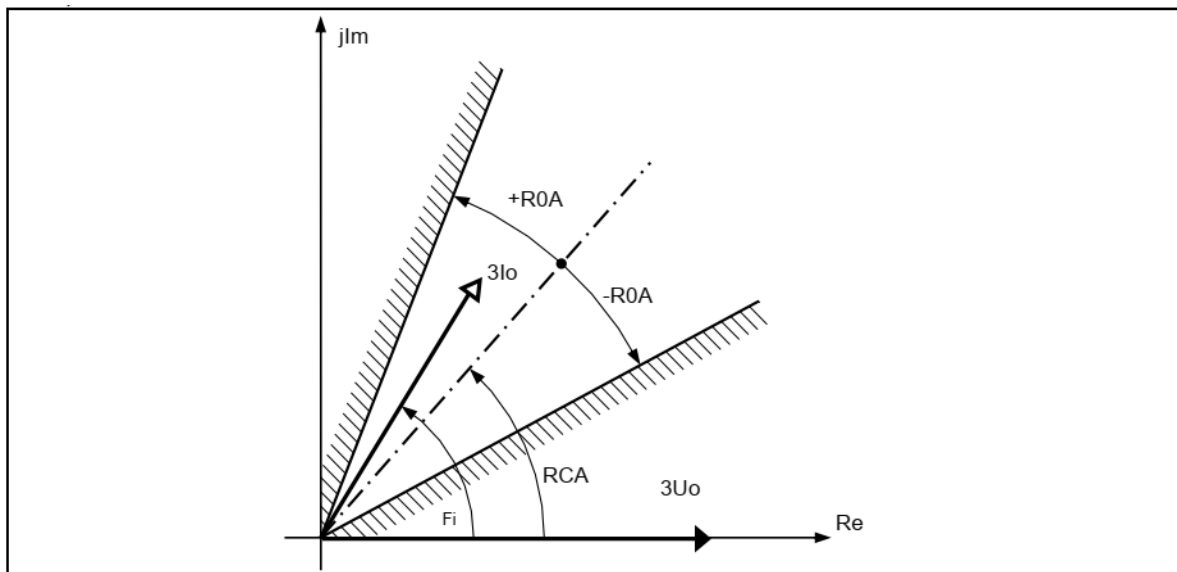

Figure 1-1 The directional decision

4.1.20.3. Structure of the directional residual overcurrent protection algorithm

Fig.1-2 shows the structure of the directional residual overcurrent protection (TOC51N) algorithm.

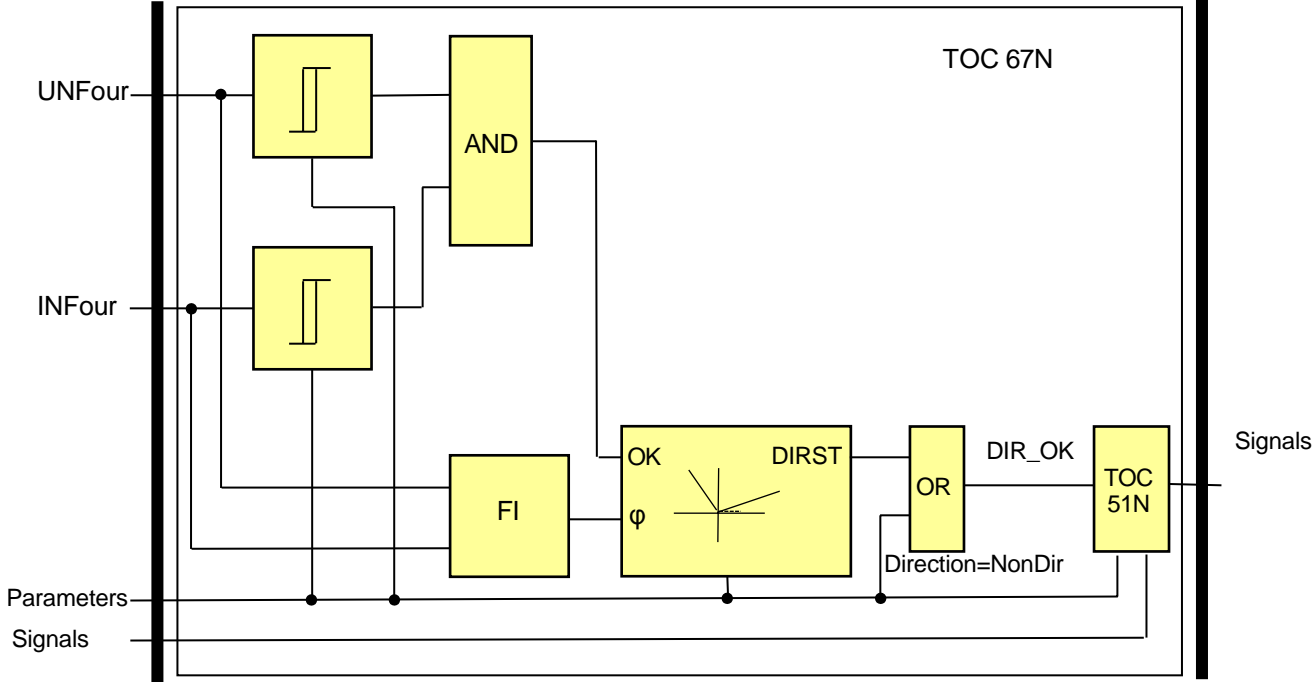

Figure 1-2 Structure of the residual directional overcurrent protection algorithm

The **inputs** are

- the RMS value of the fundamental Fourier component of the residual current ($IN=3I_0$),
- the RMS value of the fundamental Fourier component of the residual voltage ($UN=3U_0$),
- parameters,
- status signals.

The **outputs** are

- the binary output status signals.

The **software modules** of the residual directional overcurrent protection function:

Comparison

These modules decide if the RMS values of the fundamental Fourier component of the residual current and voltage are above the limits needed for correct directional decision.

FI calculation

This module calculates the vector angle between the residual voltage and the residual current.

DIRST

The directional decision.

TOC51N

Non-directional residual overcurrent protection function.

The following description explains the details of the individual components.

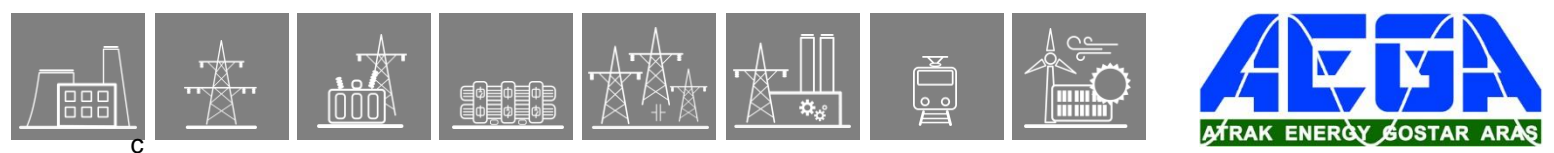

4.1.20.3.1. Enabling the directional decision (Comparison)

These modules decide if the RMS values of the fundamental Fourier component of the residual current and voltage are above the limits needed for correct directional decision.

Integer parameters

Parameter name	Title	Unit	Min	Max	Step	Default
The threshold value for the $3U_0$ zero sequence voltage, below which no directionality is possible. % of the rated voltage of the voltage transformer input.						
TOC67N_UoMin_IPar_	Min Res Voltage	%	1	20	1	2
The threshold value for the $3I_0$ zero sequence current, below which no operation is possible. % of the rated current of the current transformer input.						
TOC67N_IoMin_IPar_	Min Res Current	%	1	50	1	5

Table 1-1 The integer parameters for enabling the directional decision

The **input signals** are the RMS values of the fundamental Fourier component of the residual current and voltage.

The **internal output status signal** for enabling the directional decision is true if both the residual voltage and the residual current is above the preset limits.

4.1.20.3.2. Calculation of the vector angle (FI calculation)

This module calculates the phase angle between the residual voltage and the residual current. The reference signal is the residual voltage according to *Figure 1-1*.

The **input signals** are the fundamental Fourier components of the residual current and voltage.

The **internal output signal** is the calculated phase angle.

4.1.20.3.3. Directional decision (DIRST)

This module decides if the phase angle between the residual voltage and the residual current is within the limit range defined by the preset parameter. The operation of this function is explained in *Figure 1-1*.

The input signals are

- The enabling status signal from the Comparison modules in AND relationship.
- The calculated phase angle between the residual voltage and the residual current.
- Parameters.

The **internal output signal** of the directional decision is TRUE if the phase angle between the residual voltage and the residual current is within the limit range defined by the preset parameters OR if non-directional operation is selected by the preset parameter TOC67N_Dir_EPar_ (Direction=NonDir).

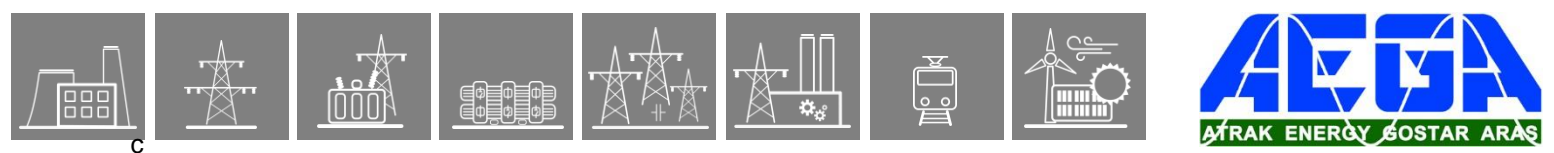

Enumerated parameters

Parameter name	Title	Selection range	Default
Directionality of the function			
TOC67N_Dir_EPar_	Direction	NonDir,Forward-Angle,Backward-Angle,Forward-I*cos(fi),Backward-I*cos(fi),Forward-I*sin(fi),Backward-I*sin(fi),Forward-I*sin(fi+45),Backward-I*sin(fi+45)	Forward-Angle

*The forward direction is defined by the RCA characteristic angle (See Tables 1-5 below).

Table 1-2 The enumerated parameters of the directional decision

Short explanation of the enumerated parameter selection

Selected value	Explanation
NonDir,	Operation according to non-directional TOC51N
Forward-Angle	See <i>Figure 1-1</i> , set ROA and RCA as required
Backward-Angle	RCA=RCAset+180°, set ROA and RCA as required
Forward-I*cos(fi)	RCA=0°fix, ROA=85°fix, the setting values RCA and ROA are not applied
Backward-I*cos(fi)	RCA=180°fix, ROA=85°fix, the setting values RCA and ROA are not applied
Forward-I*sin(fi)	RCA=90°fix, ROA=85°fix, the setting values RCA and ROA are not applied
Backward-I*sin(fi)	RCA=-90°fix, ROA=85°fix, the setting values RCA and ROA are not applied
Forward-I*sin(fi+45)	RCA=45°fix, ROA=85°fix, the setting values RCA and ROA are not applied
Backward-I*sin(fi+45)	RCA=-135°fix, ROA=85°fix, the setting values RCA and ROA are not applied

Table 1-3 Explanation of the enumerated parameter “Direction”

Integer parameters

Parameter name	Title	Unit	Min	Max	Step	Default
Operating angle (See <i>Figure 1-1</i>)						
TOC67N_ROA_IPar_	Operating Angle	deg	30	85	1	60
Characteristic angle (See <i>Figure 1-1</i>)						
TOC67N_RCA_IPar_	Characteristic Angle	deg	-180	180	1	60

Table 1-4 Integer parameters of the directional decision

4.1.20.4.4. Summary of the input signals

Binary status signals

The directional residual overcurrent protection function has a binary input status signal. **The conditions are defined by the user applying the graphic equation editor.**

Binary status signal	Title	Explanation
TOC67N_BlK_GrO_	Block	Blocking input status signal

Table 1-16 The binary input signal of the directional residual overcurrent protection function

4.1.20.4.5. The function block

The function block of the residual directional overcurrent protection function is shown in Figure 1-3. This block shows all binary input and output status signals that are applicable in the graphic equation editor.

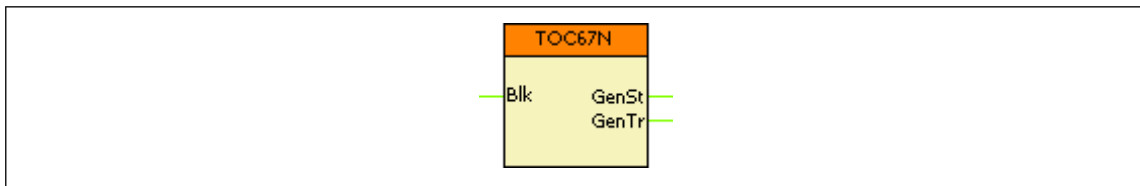
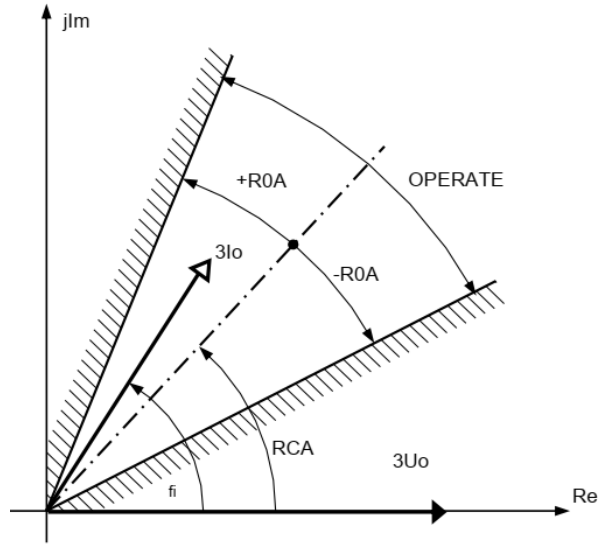

Figure 1-3 The function block of the residual overcurrent protection function

The names of the input and output signals are parts of the “Binary status signal” names listed in Table 1-15 and Table 1-16 above.

4.1.20.5. APPENDIX Pre-configured setting values of the directional residual overcurrent protection function

4.1.20.5.1. Setting: Direction = Forward-Angle



For the operation the residual current ($3I_o$) must be within the “OPERATE” area.

Additional conditions for operation:

- The magnitude of the residual current is above the setting value:
 $|3I_o| > \text{“Start current”}$
- The magnitude of the residual voltage is above the setting value:
 $|3U_o| > \text{“Min Res Voltage”}$

4.1.20.5.2. Setting: Direction = Backward-Angle

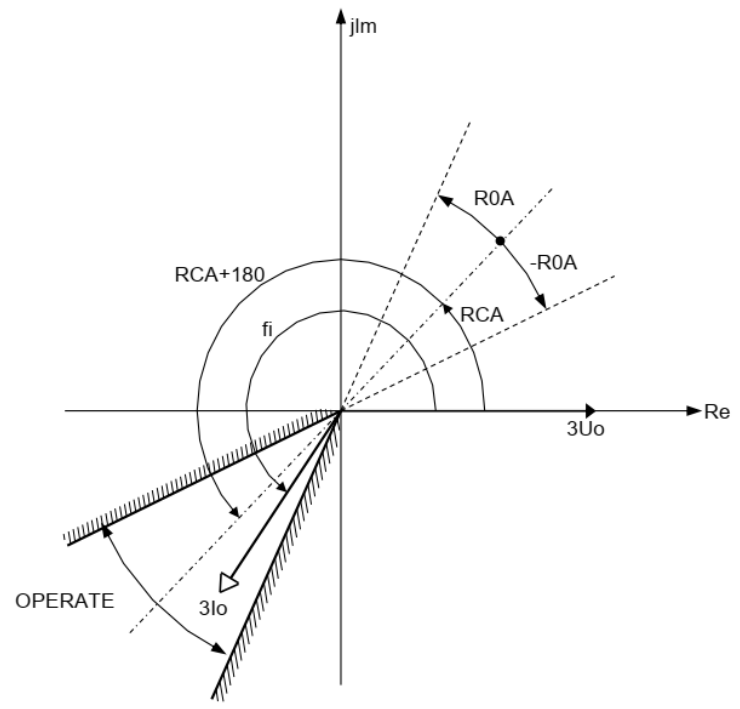

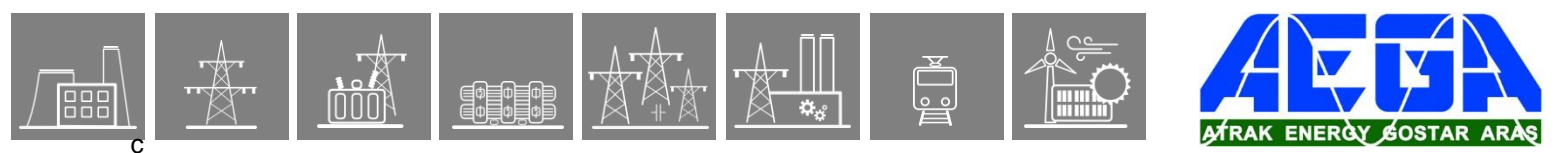

For the operation the residual current ($3I_0$) must be within the “OPERATE” area.

Additional conditions for operation:

- The magnitude of the residual current is above the setting value:
 $|3I_0| > \text{“Start current”}$
- The magnitude of the residual voltage is above the setting value:
 $|3U_0| > \text{“Min Res Voltage”}$

4.1.20.5.3. Setting: Direction = Forward- $I \cdot \cos(\phi_i)$

For the operation the residual current ($3I_0$) must be within the “OPERATE” area.

Additional conditions for operation:

- The magnitude of the residual current projected to the real axis is above the setting value:
 $|3I_0| \cdot \cos(\phi_i) > \text{“Start current”}$
- The magnitude of the residual voltage is above the setting value:
 $|3U_0| > \text{“Min Res Voltage”}$

4.1.20.5.4. Setting: Direction = Backward-I*cos(fi)

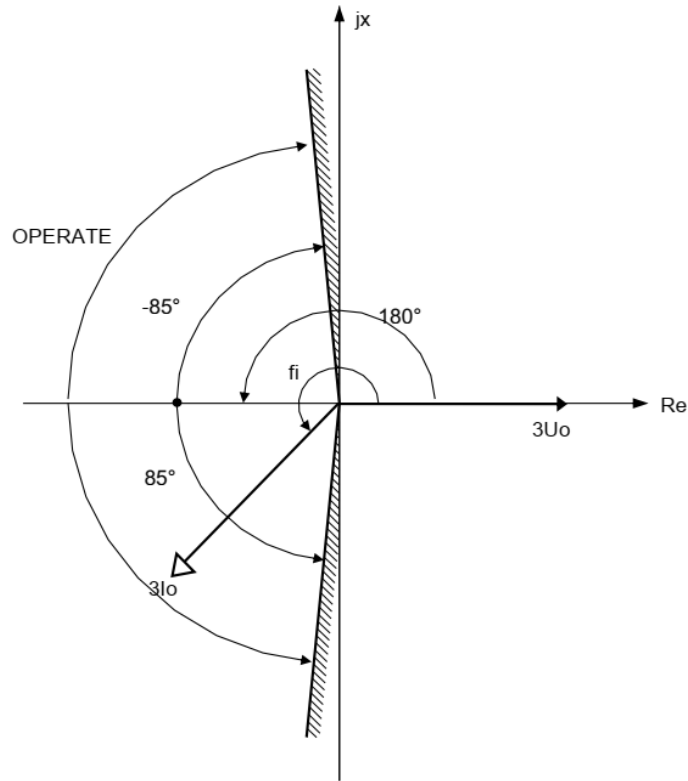

For the operation the residual current ($3I_o$) must be within the “OPERATE” area.

Additional conditions for operation:

- The magnitude of the residual current projected to the negative real axis is above the setting value:

$$|3I_o| \cdot \cos(\phi_i - 180) > \text{“Start current”}$$

- The magnitude of the residual voltage is above the setting value:

$$|3U_o| > \text{“Min Res Voltage”}$$

4.1.20.5.5. Setting: Direction = Forward-I*sin(fi)

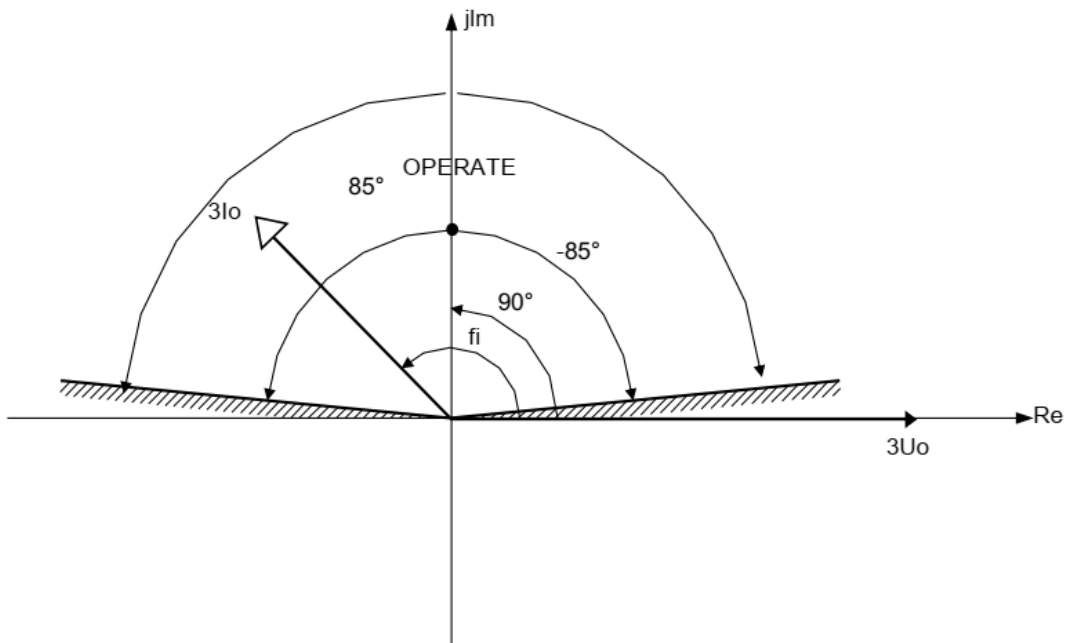

For the operation the residual current ($3I_o$) must be within the “OPERATE” area.

Additional conditions for operation:

- The magnitude of the residual current projected to the imaginary axis is above the setting value:

$$|3I_o| \cdot \sin(\phi_i) > \text{“Start current”}$$

- The magnitude of the residual voltage is above the setting value:

$$|3U_o| > \text{“Min Res Voltage”}$$

4.1.20.5.6. Setting: Direction = Backward- $I \cdot \sin(\phi_i)$

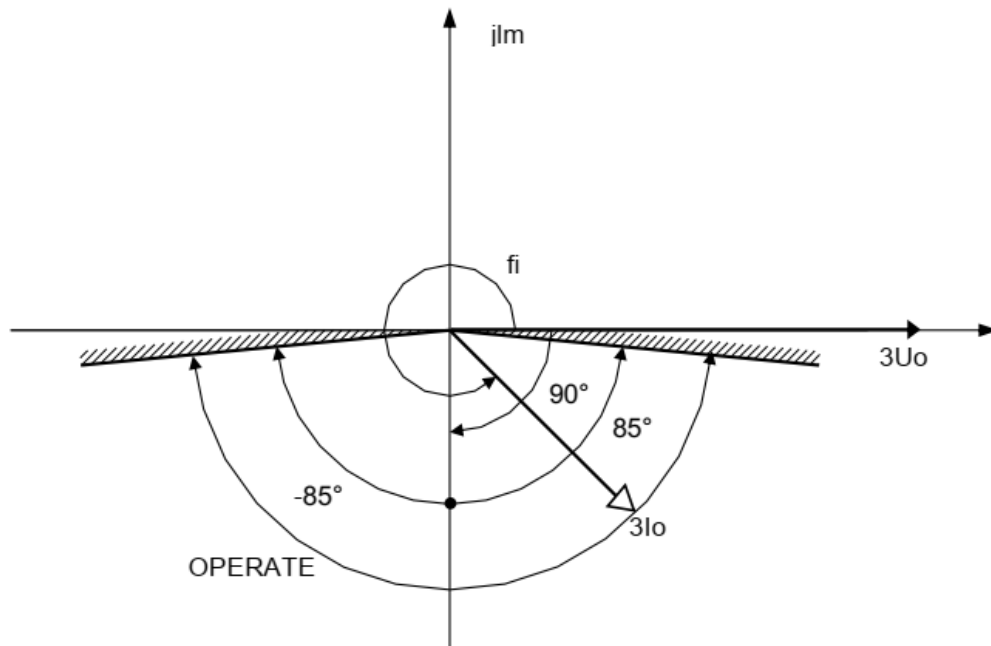

For the operation the residual current ($3I_o$) must be within the “OPERATE” area.

Additional conditions for operation:

- The magnitude of the residual current projected to the negative imaginary axis is above the setting value:

$$|3I_o| \cdot \sin(\phi_i - 180) > \text{“Start current”}$$

- The magnitude of the residual voltage is above the setting value:

$$|3U_o| > \text{“Min Res Voltage”}$$

4.1.20.5.7. Setting: Direction = Forward-I*sin(fi+45)

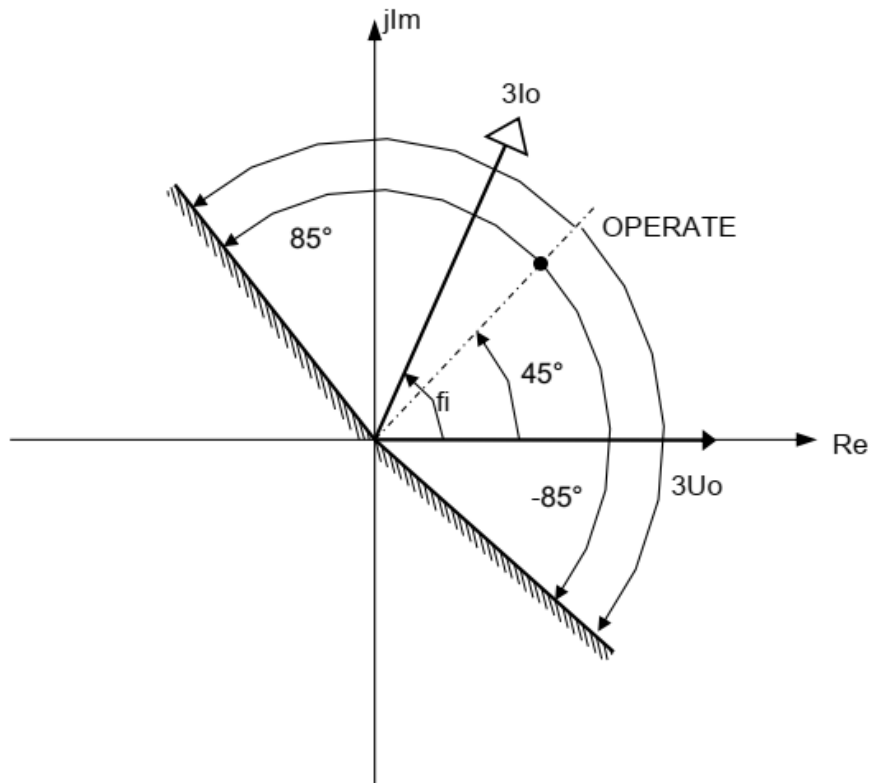

For the operation the residual current ($3I_o$) must be within the “OPERATE” area.

Additional conditions for operation:

- The magnitude of the residual current projected to the line of the characteristic angle (45°) is above the setting value:

$$|3I_o| \cdot \cos(\phi_i - 45^\circ) > \text{“Start current”}$$

- The magnitude of the residual voltage is above the setting value:

$$|3U_o| > \text{“Min Res Voltage”}$$

Note: Because of the characteristic angle is 45° ,
 $\cos(\phi_i - 45^\circ) = \sin(\phi_i + 45^\circ)$

4.1.20.5.8. Setting: Direction = Backward- $I \cdot \sin(\phi_i + 45^\circ)$

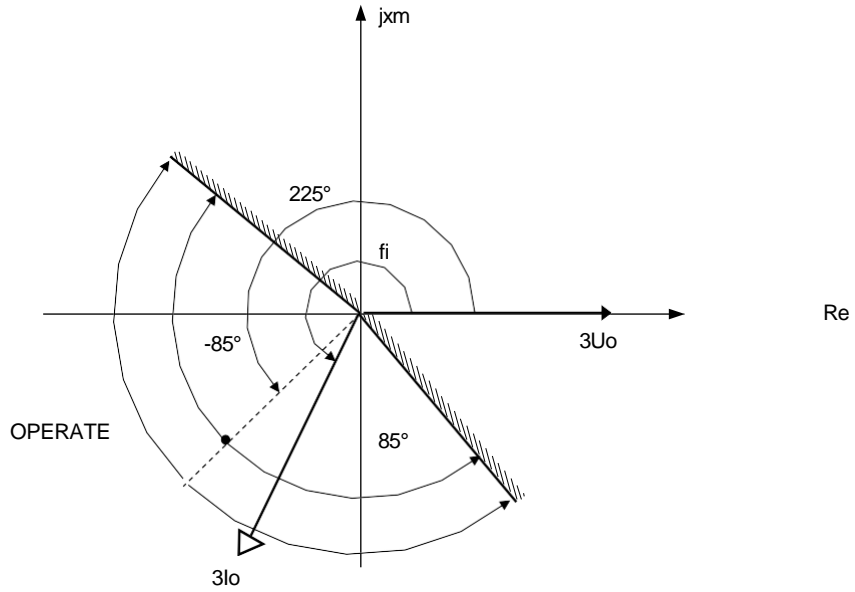

For the operation the residual current ($3I_o$) must be within the “OPERATE” area. Additional conditions for operation:

- The magnitude of the residual current projected to the line of the characteristic angle (225°) is above the setting value:

$$|3I_o| \cdot \cos(\phi_i - 225^\circ) > \text{“Start current”}$$

- The magnitude of the residual voltage is above the setting value:

$|3U_o| > \text{“Min Res Voltage”}$ Note: Because of the characteristic angle is 225° , $\cos(\phi_i - 225^\circ) = \sin(\phi_i + 45^\circ)_{BW}$

4.1.21. Inrush current detection function

4.1.21.1. Application

When an inductive element with an iron core (transformer, reactor, etc.) is energized, high current peak values can be detected. This is caused by the transient asymmetric saturation of the iron core as a nonlinear element in the power network. The sizing of the iron core is usually sufficient to keep the steady state magnetic flux values below the saturation point of the iron core, so the inrush transient slowly dies out. These current peaks depend also on random factors such as the phase angle at energizing. Depending on the shape of the magnetization curve of the iron core, the detected peaks can be several times above the rated current peaks. Additionally, in medium or high voltage networks, where losses and damping are low, the indicated high current values may be sustained at length. Figure 1-1 shows a typical example for the inrush current shapes of a three-phase transformer.

As a consequence, overcurrent relays, differential relays or distance relays may start, and because of the long duration of the high current peaks, they may generate an unwanted trip command.

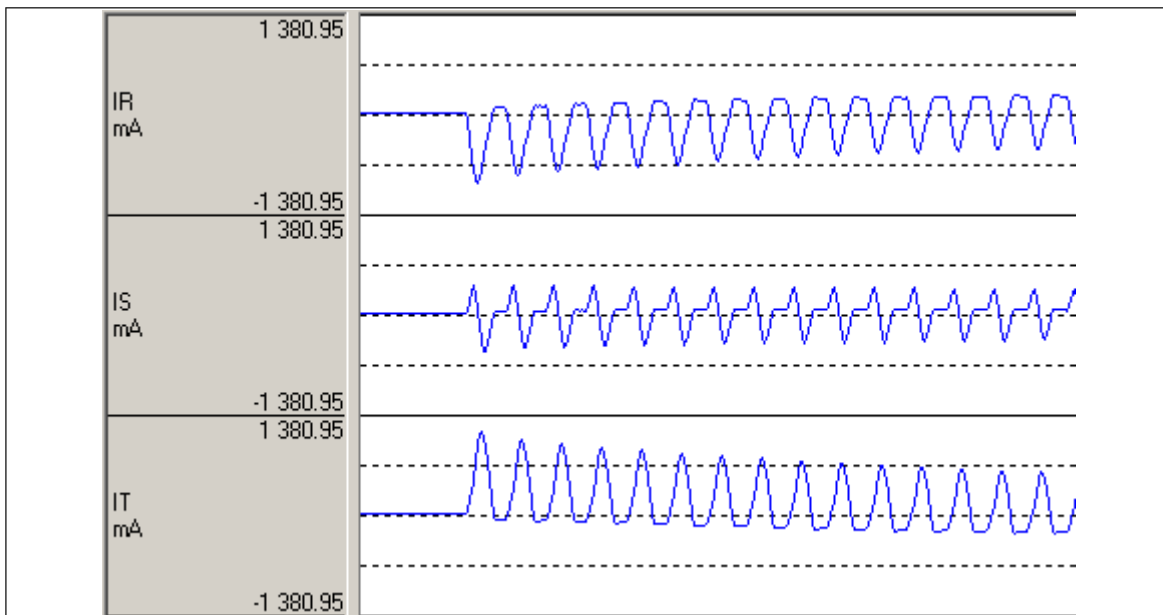
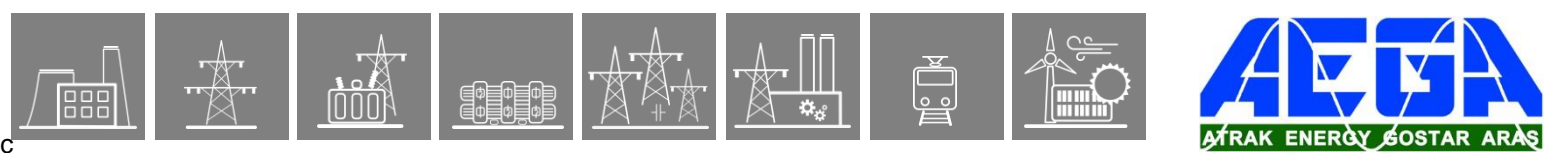

Figure 1-1 Example: A typical inrush current

The inrush current detection function can distinguish between high currents caused by overload or faults and the high currents during the inrush time.

Using the inrush detection binary signals, other protection functions can be blocked during the transient period so as to avoid the unwanted trip.

Some protection functions use these signals automatically, but a stand-alone inrush detection function block is also available for application at the user's discretion.



4.1.21.1.1. Mode of operation

The operating principle of the inrush current detection function is based on the special shape of the inrush current.

As Figure 1-1 shows, the typical inrush current in one or two phases is distorted and asymmetrical to the time axis: for example, in IT of the Figure above the positive peaks are high while no peaks can be detected in the negative domain.

The theory of the Fourier analysis states that even harmonic components (2nd, 4th etc.) are dominant in waves distorted as described above. The component with the highest value is the second one.

Typical overload and fault currents do not contain high even harmonic components.

The inrush current detection function processes the Fourier basic harmonic component and the second harmonic component of the three phase currents. If the ratio of the second harmonic and the base Fourier harmonic is above the setting value of the parameter 2nd Harm Ratio, an inrush detection signal is generated.

The signal is output only if the base harmonic component is above the level defined by the setting of the parameter IPh Base Sens. This prevents unwanted operation in the event that low currents contain relatively high error signals.

The function operates independently using all three phase currents individually, and additionally, a general inrush detection signal is generated if any of the phases detects inrush current.

The function can be disabled by the binary input INR2_Blk_GrO_. This signal is the result of logic equations graphically edited by the user.

The **inputs** of the inrush current detection function are

- the basic and second Fourier components of three phase currents,
- binary input,
- parameters.

The **output** signals of the inrush current detection function are

- inrush detection in phases L1, L2 or L3 individually,
- a general inrush detection signal.

4.1.21.2. Inrush current detection function overview

The function block of the inrush current detection function is shown in Figure 2-1. This block shows all binary input and output status signals that are applicable in the graphic equation editor.

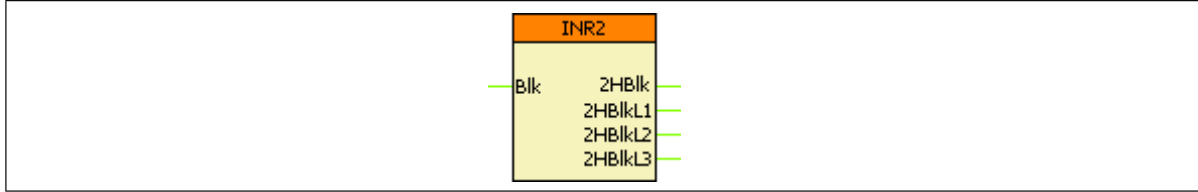

Figure 2-1 The function block of the inrush current detection function

4.1.21.2.1. Settings

4.1.21.2.1.1. Parameters

The available parameters are listed below in order of their appearance in the *parameters* menu. If the setting range of a parameter should be extended, contact Protecta Support.

Table 2-1 Parameters of the inrush current detection function

TITLE	DIM	RANGE	STEP	DEFAULT	EXPLANATION
Operation	-	Off, On	-	Off	Enabling the function
2 nd Harm Ratio	%	5 – 50	1	15	Ratio of the second harmonic Fourier component and the basic harmonic component.
IPh Base Sens	%	20 – 100	1	30	The function operates only if the base harmonic component is be above this setting

4.1.21.2.2. Function I/O

This section briefly describes the analogue and digital inputs and outputs of the function block.

4.1.21.2.2.1. Analogue inputs

The basic and second Fourier components of three phase currents.

4.1.21.2.2.2. Binary input signals (graphed output statuses)

The conditions of the binary inputs are defined by the user, applying the graphic equation editor (*Logic Editor*). Parts written in **bold** are seen on the left side function block in the Logic editor.

Table 2-2 The binary input signal of the inrush current detection function

BINARY INPUT SIGNAL	EXPLANATION
INR2_ BIk _GrO_	Blocking input of the function

4.1.21.2.2.3. Binary output signals (graphed input statuses)

These signals can be used in EuroCAP to assign to LED, user LCD object etc. Parts written in **bold** are seen on the right side of the function block in the *Logic Editor*.

Table 2-3 The binary output signals of the inrush current detection function

BINARY OUTPUT SIGNAL	SIGNAL TITLE	EXPLANATION
INR2_ 2HBIk _GrI_	Inrush	Inrush current detected in one of the three phases
INR2_ 2HBIkL1 _GrI_	Inrush L1	Inrush current detected in phase L1
INR2_ 2HBIkL2 _GrI_	Inrush L2	Inrush current detected in phase L2
INR2_ 2HBIkL3 _GrI_	Inrush L3	Inrush current detected in phase L3

4.1.21.2.2.4. Online data

Visible values on the *online data* page.

Table 2-4 Online displayed data of the inrush current detection function

SIGNAL TITLE	DIMENSION	EXPLANATION
Inrush L1	-	Inrush current detected in phase L1
Inrush L2	-	Inrush current detected in phase L2
Inrush L3	-	Inrush current detected in phase L3
Inrush	-	Inrush current detected in one of the three phases

4.1.21.2.2.5. Events

The following events are generated in the event list, as well as sent to the SCADA according to the configuration.

Table 2-5 Generated events of the inrush current detection function

EVENT	VALUE	EXPLANATION
2 nd Harm. Restraint	off, on	Inrush current detected in one of the three phases

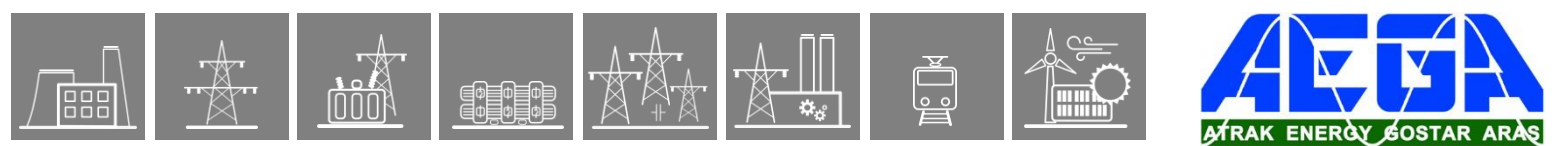

4.1.22. HV AutoReclosing

4.1.22.1. Application

The HV automatic reclosing function for high voltage networks can realize up to four shots of reclosing. The dead time can be set individually for each reclosing and separately for single- phase faults and for multi-phase faults.

The starting signal of the cycles can be generated by any combination of the protection functions or external signals of the binary inputs. The selection to generate the binary input REC79_St_GrO_ (Protection Start) is made by graphic equation programming.

The automatic reclosing function is triggered if as a consequence of a fault a protection function generates a trip command to the circuit breaker and the protection function resets because the fault current drops to zero or the circuit breaker's auxiliary contact signals open state. According to the preset parameter values, either of these two conditions starts counting the dead time, at the end of which the HV automatic reclosing function generates a close command automatically. If the fault still exists or reappears, then within the "**Reclaim time**" (according to parameter setting REC79_Rec_TPar_), started at the close command, the protection functions picks up again and the subsequent cycle is started. If no pickup is detected within this time, then the HV automatic reclosing cycle resets and a new fault will start the procedure with the first cycle again.

The sequence of the initial actions on starting the automatic reclosing function is as follows:

- Protection starting to the binary input REC79_St_GrO_ (Protection Start) starts the action time (REC79_Act_TPar_), during its running time, the protection trip should be got.
- Triggering signal of the HV automatic reclosing function to the binary input REC79_Tr_GrO_ (AutoReclosing Start) is the protection trip, it starts the „Run” state („In progress” state, REC79_Run_GrI_) and starts the Start Signal Max Time (REC79_MaxSt_TPar_) counter. During its running time, according to the preset parameter value, protection trip resetting or CB open signal (starting signal) should be got.
- Starting signal of the HV automatic reclosing function can be protection trip resetting or CB open signal which starts the dead time.
- Close command is generated at the dead time end, and it starts the reclaim time (REC79_Rec_TPar).

There are some additional requirements to perform automatic reclosing:

- The HV automatic reclosing function can be blocked by the variable REC79_Blk_GrO_, for which the user has to compose a graphic logical equation.
- After a pickup of the protection function, a timer starts to measure the "**Action time**" (the duration of which depends on parameter setting REC79_Act_TPar_ (Action time)). The trip command must be generated within this time to start reclosing cycles, or else the HV automatic function enters dynamic blocked state.
- At the moment of generating the close command, the circuit breaker must be ready for operation, which is signaled via binary input REC79_CBRdy_GrO_ (CB Ready). The preset parameter value REC79_CBTO_TPar_ (CB Supervision time) decides how long the HV automatic reclosing function is allowed to wait when the function is in "In Progress" state. If the signal is not received during this time, then the HV automatic reclosing function terminates and after a "**dynamic blocking time**" (depending on the preset parameter value REC79_DynBlk_TPar_ (Dynamic Blocking time)) the function resets.

Depending on the preset parameter value, the HV automatic reclosing function can influence the operation of the protection functions as well. The binary outputs of the HV automatic reclosing function, including the "In progress" (Run) state, can be applied for this purpose in the graphic equation editor. (See Chapter 1.3.5)

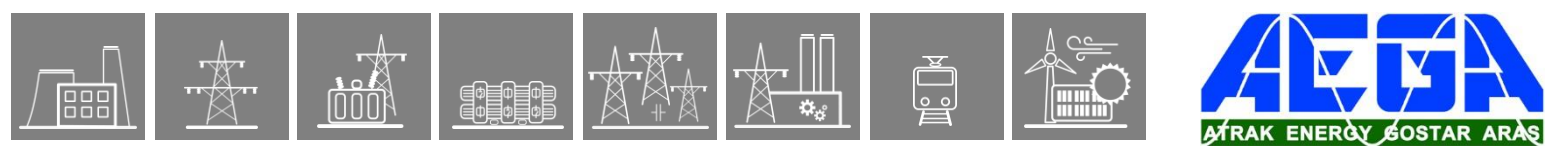

In case of a manual close command which is assigned to the logic variable REC79_ManCI_GrO_ (Manual Close) using graphic equation programming, a preset parameter value decides how long the HV automatic reclosing function should be disabled **after the manual close** command.

The **duration of the close command** depends on preset parameter value REC79_Close_TPar_ (Close command time), but the close command terminates if any of the protection functions issues a trip command.

4.1.22.2. Mode of operation

The HV automatic reclosing function can control up to four reclosing cycles. Depending on the preset parameter value REC79_CycEn_EPar_ (Reclosing cycles), there are different modes of operation:

Disabled	No automatic reclosing is selected,
1. Enabled	Only one automatic reclosing cycle is selected,
1.2. Enabled	Two automatic reclosing cycles are activated,
1.2.3. Enabled	Three automatic reclosing cycles are activated,
1.2.3.4. Enabled	All automatic reclosing cycles are activated.

The function can be switched Off /On using the parameter REC79_Op_EPar_ (Operation).

The user can also block the HV automatic reclosing function applying the graphic equation editor. The binary status variable to be programmed is REC79_BlK_GrO_ (Block).

If the device is generally blocked, then the HV automatic reclosing function is also blocked.

4.1.22.2.1. Starting the HV automatic reclosing cycle

Depending on the present parameter value REC79_St_EPar_ (Reclosing started by), the HV automatic reclosing function can be started either by resetting of the TRIP command (setting: Trip reset) or by the binary signal indicating the open state of the circuit breaker (setting: CB open).

If the reset state of the TRIP command is selected to start the HV automatic reclosing function, then the binary status variable to be programmed is: REC79_Tr_GrO_ (AutoReclosing Start).

If the open state of the circuit breaker is selected to start the HV automatic reclosing function (CB open), then also the binary status variable REC79_CBOpen_GrO_ (CB OPEN single-pole) is additionally to be programmed. This signal should be TRUE if at least one of the poles is open

The HV automatic reclosing function gets the trip commands of the protection functions intended to trigger the reclosing function. The conditions for detecting the triggered state of the protection functions are defined by the user applying the graphic equation editor. The binary status variable to be programmed is: REC79_Tr_GrO_ (AutoReclosing Start). This signal starts a dedicated timer, the elapsed time of which is compared to the preset parameter value REC79_MaxSt_TPar_ (Start-signal Max.Tim).

The HV automatic reclosing function enters the dynamic blocking state:

- If the parameter selected for REC79_St_EPar_ (Reclosing started by) is "Trip reset", and the trip impulse is too long
- If the parameter selected for REC79_St_EPar_ (Reclosing started by) is "CB open", then during the runtime of the timer CB open signal is not received

For further information about the dynamic blocking state see Chapter 1.2.17.

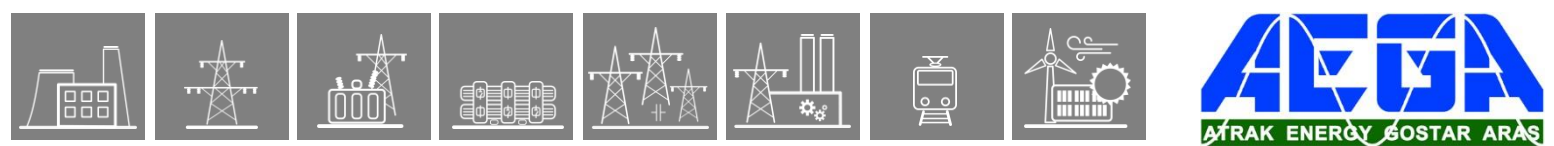

4.1.22.2.2. Starting the dead time counter

In the base case, the dead time counter of any reclosing cycle is started by the starting signal (See Chapter 1.2.1) but starting can be delayed. The delay is activated while the value of the REC79_DtDel_GrO_ (Dead Time Start Delay) status signal is TRUE. The conditions are defined by the user applying the graphic equation editor. This delay is limited by the timer parameter REC79_DtDel_TPar_ (DeadTime Max.Delay).

4.1.22.2.3. The dead time

For all four reclosing cycles, separate dead times can be defined for single-phase trip commands (as a consequence of single-phase faults) and for three-phase trip commands (as a consequence of multi-phase faults).

The timer parameters for single-phase trip commands are:

REC79_1PhDT1_TPar_	1. Dead Time 1Ph
REC79_1PhDT2_TPar_	2. Dead Time 1Ph
REC79_1PhDT3_TPar_	3. Dead Time 1Ph
REC79_1PhDT4_TPar_	4. Dead Time 1Ph

The timer parameters for three-phase trip commands are:

REC79_3PhDT1_TPar_	1. Dead Time 3Ph
REC79_3PhDT2_TPar_	2. Dead Time 3Ph
REC79_3PhDT3_TPar_	3. Dead Time 3Ph
REC79_3PhDT4_TPar_	4. Dead Time 3Ph

The different dead time settings can be justified as follows: in case of a single-phase fault, only the circuit breakers of the faulty phase open. In this case, due to the capacitive and inductive coupling of the healthy phases, the extinction of the secondary electric arc at the fault location can be delayed. Consequently, a longer dead time is needed for the fault current to extinguish than in the case of a three-phase open state, when no coupled voltage can sustain the fault current.

From other point of view, in case of a transmission line connecting two power systems, only a shorter dead time is allowed for the three-phase open state because, due to the possible power unbalance between the interconnected systems, a large angle difference can be reached if the dead time is too long. If only a single phase is open, then the two connected healthy phases and the ground can sustain the synchronous operation of both power systems.

4.1.22.2.4. Special dead time for the first cycle

This special dead time can be necessary for the following reason:

Assume a line between substations A and B, and a protection system without tele-protection. In the event of a three-phase fault near substation B, the protection at A generates a trip command according to the second zone's time setting only, and starts measuring the dead time with considerable delay as compared to the protection at B, which generates a trip command immediately due to the close-in fault.

If the three-phase dead time is too short, the HV automatic reclosing at B may attempt to close the circuit breaker during the running time of the second zone trip at A, which means that the fault is not cleared yet. Consequently, a prolonged dead time is needed if the fault was detected in the first zone.

The preset timer parameter value is REC79_3PhDT1_TPar_2 (1. special DT 3Ph).

The special dead time is valid if the REC79_1cyc3PhFlt_GrO_ (3PhFault for Spec.DT1) status signal is TRUE. The conditions are defined by the user applying the graphic equation editor.



4.1.22.2.5. Reduced dead time

Dead time reduction may be applicable under the following circumstances:

If healthy voltage is measured in all three phases during the dead time, this means that no fault exists on the line. In this case, the expiry of the normal dead time need not be waited for, a reclosing attempt can be initiated immediately.

The dead time is terminated immediately if the REC79_RDT_GrO_ (Reduced DeadTime) status signal is TRUE. The conditions are defined by the user applying the graphic equation editor.

4.1.22.2.6. Three-phase trip

The HV automatic reclosing function is prepared to get the general trip command as programmed to the binary input status variable REC79_Tr_GrO_ (AutoReclosing Start) and the three-phase trip signal REC79_3PhTr_GrO_ (3Ph Trip). If no three-phase trip signal is received, then it performs automatic reclosing cycles with the dead times according to the setting for single phase cycles. The three-phase cycles are controlled by the status variable REC79_3PhTr_GrO_ (3Ph Trip). If this is TRUE, three-phase cycles are performed. The conditions are defined by the user applying the graphic equation editor.

If, during the cycles, the three-phase dead time is applied once, then all subsequent cycles will consider the three-phase dead time settings, too.

Three-phase reclosing can be disabled by the preset parameter value REC79_3PhRecBlk_BPar_ (Disable 3Ph Rec.). If the value of this parameter is TRUE, then if a three-phase trip command is received, the HV automatic reclosing function enters “Dynamic blocked” state.

For further information about the dynamic blocked state, see Chapter 1.2.17.

4.1.22.2.7. Checking the ready state of the circuit breaker

At the end of the dead time, reclosing is possible only if the circuit breaker can perform the command.

The binary variable REC79_CBRdy_GrO_ (CB Ready) indicates this state. The conditions are defined by the user applying the graphic equation editor.

If the circuit breaker is not ready, the controller functions wait for a pre-programmed time for this state. The waiting time is defined by the user as parameter value REC79_CBTO_TPar_ (CB Supervision time). If this condition is not fulfilled during the waiting time, then the HV automatic reclosing function enters “Dynamic blocked” state.

For further information about the dynamic blocked state, see Chapter 1.2.17.

4.1.22.2.8. Reclosing with synchronous state supervision

Reclosing is possible only if the conditions required by the *Synchro-check*, *synchro-switch* function are fulfilled. This state is signaled by the binary variable REC79_SynRel_GrO_ (SYNC Release) from the *Synchro-check*, *synchro-switch* function. The conditions are defined by the user applying the graphic equation editor. The HV automatic reclosing function waits for a pre-programmed time for this signal. This time is defined by the user as parameter value REC79_SYN1_TPar_ (SynCheck Max Time). If the “SynRel” signal is not received during the running time of this timer, then the “synchronous switch” operation is started (See Chapter

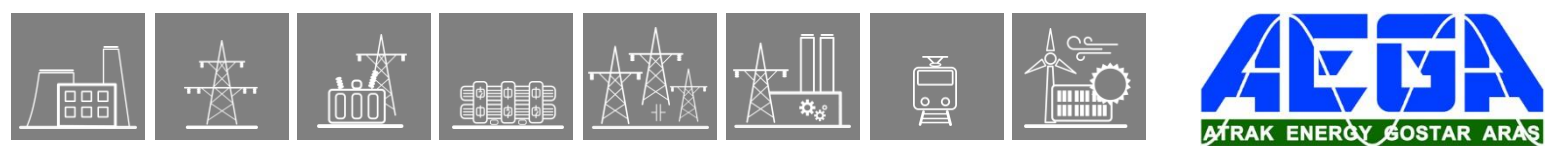

1.2.9) and the binary output signal REC79_CIReq_GrI_ (CIReq) is generated which is connected to the *Synchro-check*, *synchro-switch* function.

4.1.22.2.9. Reclosing with synchronous switching

If the conditions of the synchronous state are not fulfilled, another timer starts. This waiting time is defined by the user as parameter value REC79_SYN2_TPar_ (SynSW Max Time).

The separate *Synchro-check*, *synchro-switch* function controls the generation of the close command in case of relatively rotating voltage vectors on both sides of the circuit breaker to make contact at the synchronous state of the rotating vectors. For this calculation, the closing time of the circuit breaker must be defined in that function.

This mode of operation is indicated by the output variable REC79_CIReq_GrI_ (CIReq).

If no switching is possible during the running time of this timer, then the HV automatic reclosing function enters “Dynamic blocked” state and resets.

For further information about the dynamic blocked state, see Chapter 1.2.17.

4.1.22.2.10. Impulse duration of the CLOSE command

The “Close” impulse is generated as one of the output status signals of the HV automatic reclosing function REC79_Close_GrI_ (Close). This signal is common to all three phases. The impulse duration is defined by the user setting the timer parameter REC79_Close_TPar_ (Close command time).

4.1.22.2.11. Behavior after reclosing

When the close command is generated, a timer is started to measure the “Reclaim time”. The duration is defined by the parameter value REC79_Rec_TPar_ (Reclaim time), but it is prolonged up to the reset of the close command (if the close command duration is longer than the reclaim time set). If the fault is detected again during this time, then the sequence of the HV automatic reclosing cycles continues. If no fault is detected, then at the expiry of the reclaim time the reclosing is evaluated as successful and the function resets. If fault is detected after the expiry of this timer, then the cycles restart with the first reclosing cycle.

If the user programmed the status variable REC79_St_GrO_ (Protection Start) and it gets TRUE during the Reclaim time, then the HV automatic reclosing function continues even if the trip command is received after the expiry of the Reclaim time.

4.1.22.2.12. Behavior after manual close command

This state of manual close command is signaled by the binary variable REC79_ManCI_GrO_ (Maunal Close). The conditions are defined by the user applying the graphic equation editor.

After a manual close command, the HV automatic reclosing function enters “Not Ready” state for the time period defined by parameter REC79_MC_TPar_ (Block after Man.Close). For “Not Ready” state, see Chapter 1.2.18.

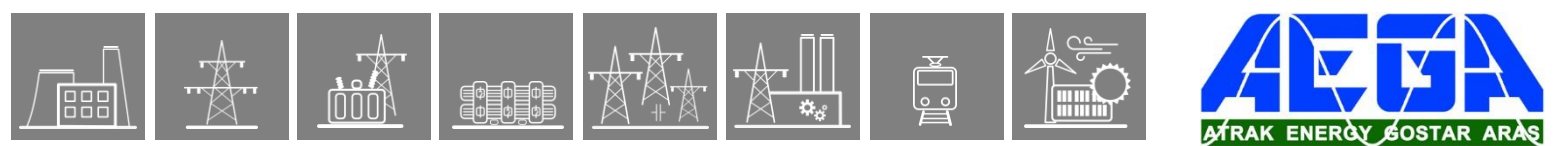

If the manual close command is received during the running time of any of the cycles, then the HV automatic reclosing function enters “Dynamic blocked” state and resets. For dynamic blocked state, see Chapter 1.2.17.

4.1.22.2.13. Behavior in case of evolving fault

In case of evolving faults (when a single-phase fault detected changes to multi-phase fault), the behavior of the automatic reclosing function is controlled by the preset parameter value REC79_EvoFlt_EPar_ (Evolving fault). The options are

- “Block Reclosing” or
- “Start 3Ph Rec.”.

If “Block Reclosing” is selected, the HV automatic reclosing function enters dynamic blocked state (See Chapter 1.2.17.), and the subsequent reclosing command is not generated.

If “Start 3Ph Rec.” is selected, the HV automatic reclosing function goes on performing the subsequent cycle according to the three-phase parameters.

4.1.22.2.14. The final trip

If the fault still exists at the end of the last cycle, the HV automatic reclosing function generates the signal for final trip: REC79_FinTr_GrI_ (FinTr). The same final trip signal is generated in case of an evolving fault if “Block Reclosing” is selected (see Chapter 1.2.13). After final trip, the HV automatic reclosing function enters “Dynamic blocked” state.

A final trip command is also generated if, after a multi-phase fault, a fault is detected again during the dead time.

For further information about the dynamic blocked state, see Chapter 1.2.17.

4.1.22.2.15. Action time

The user can compose the binary status variable REC79_St_GrO_ (Protection Start) to indicate the start of the protection functions, whose operations are related to the HV automatic reclosing function. See Chapter 1.1 This signal starts the “Action time”, the duration of which is defined by the preset parameter value REC79_Act_TPar_ (Action time). During the running time, the HV automatic reclosing function waits for the trip command. If no trip command is received, then the HV automatic reclosing function enters “Dynamic blocked” state.

For further information about the dynamic blocked state, see Chapter 1.2.17.

4.1.22.2.16. Accelerating trip commands

Depending on the Boolean parameter settings, the automatic reclosing function block can accelerate trip commands of the individual reclosing cycles. This means that the output REC79_TrAcc_GrI_ (TrAcc) of the function block gets active for the first starting state of the protection function or at the end of the dead time of the running cycle, if the dedicated parameter enables acceleration. This signal “TrAcc” needs user-programmed graphic equations to generate the accelerated trip command.



4.1.22.2.17. Dynamic blocking conditions

There are several conditions to result dynamic blocked state of the HV automatic reclosing function. This state becomes valid if any of the conditions of the dynamic blocking get TRUE during the running time of any of the reclosing cycles.

At the time of the change to start the dynamic blocked state a timer is started, the running duration of which is defined by the time parameter REC79_DynBlk_TPar_ (Dynamic Blocking time). During its running time the function is blocked, no reclosing command is generated.

The conditions to start the dynamic blocked state are:

- There is no trip command during the “Action time” (See Chapter 1.2.15).
- The duration of the starting impulse for the HV automatic reclosing function is too long (See Chapter 1.2.1).
- If no “CB ready” signal is received at the intended time of reclosing command (See Chapter 1.2.7)
- The dead time is prolonged further then the preset parameter value REC79_DtDel_TPar_ (DeadTime Max.Delay) (See Chapter 1.2.2).
- The waiting time for the “SYNC Release” signal is too long (See Chapter 1.2.9)
- After the final trip command (See Chapter 1.2.14).
- Automatic reclosing is started during the blocking time after a manual close command (See Chapter 1.2.12)
- While *CB State Monitoring* is on, a manual open command (the status variable REC79_CBOpen_GrO_ (CB OPEN single-pole) gets TRUE without REC79_Tr_GrO_ (AutoReclosing Start).
- In case of a three-phase trip command if the preset parameter REC79_3PhRecBlk_BPar_ (Disable 3Ph Rec.) is set to TRUE. (See Chapter 1.2.6)
- In case of evolving faults, if the parameter setting for REC79_EvoFlt_EPar_ (Evolving fault) is “Block Reclosing” (See Chapter 1.2.13)
- Automatic reclosing is started during a general block (the device is blocked, see Chapter 1.2).

In a dynamic blocked state, the REC79_Blocked_GrI_ (Blocked) status signal is TRUE (similar to “Not ready” conditions).

4.1.22.2.18. “Not Ready” conditions

There are several conditions to result “Not Ready” state of the HV automatic reclosing function. This state becomes valid if any of the conditions of the blocking get TRUE outside the running time of the reclosing cycles.

- Reclosing is disabled by the parameter REC79_Op_EPar_ (Operation) if it is selected to “Off”. (See Chapter 1.2)
- No reclosing cycles are selected by the parameter REC79_CycEn_EPar_ (Reclosing cycles) if it is set to “Disabled” (See Chapter 1.2)
- The circuit breaker is not ready for operation: the result of the graphic programming of the binary variable REC79_CBRdy_GrO_ (CB Ready) is FALSE. (See Chapter 1.2.7)
- After a manual close command (See Chapter 1.2.12)
- If the parameter REC79_CBState_BPar_ (CB State Monitoring) is set to TRUE and the circuit breaker is in Open state, i.e., the value of the REC79_CBOpen_GrO_ (CB OPEN single-pole) status variable gets TRUE.
- The starting signal for automatic reclosing is selected by parameter REC79_St_EPar_ (Reclosing started by) to be “CB open” and the circuit breaker is in Open state.
- In case of a general block (the device is blocked, see Chapter 1.2).

In a “Not ready” state, the REC79_Blocked_GrI_ (Blocked) status signal is TRUE (similar to “Dynamic blocking” conditions).

4.1.22.3. Technical summary

4.1.22.3.1. Technical data

Function	Accuracy
Operating time	±1% of setting value or ±30 ms

Table 1-1 Technical data of the HV automatic reclosing function

4.1.22.3.2. Summary of the parameters

Enumerated parameters

Parameter name	Title	Selection range	Default
Switching ON/OFF the HV automatic reclosing function (See Chapter 1.2)			
REC79_Op_EPar_	Operation	Off, On	On
Selection of the number of reclosing sequences (See Chapter 1.2)			
REC79_CycEn_EPar_	Reclosing Cycles	Disabled, 1. Enabled, 1.2. Enabled, 1.2.3. Enabled, 1.2.3.4. Enabled	1. Enabled
Selection of triggering the dead time counter (trip signal reset or circuit breaker open position, see Chapter 1.2.1)			
REC79_St_EPar_	Reclosing Started by	Trip reset, CB open	Trip reset
Selection of behavior in case of evolving fault (block reclosing or perform three-phase automatic reclosing cycle, see Chapter 1.2.13)			
REC79_EvoFit_EPar_	Evolving Fault	Block Reclosing, Start 3Ph Rec.	Block Reclosing

Tables 1-2 The enumerated parameters of the HV automatic reclosing function

Timer parameters

Parameter name	Title	Unit	Min	Max	Step	Default
Dead time setting for the first reclosing cycle for single-phase fault (See Chapter 1.2.3)						
REC79_1PhDT1_TPar_	1. Dead Time 1Ph	msec	0	100000	10	500
Dead time setting for the second reclosing cycle for single-phase fault (See Chapter 1.2.3)						
REC79_1PhDT2_TPar_	2. Dead Time 1Ph	msec	10	100000	10	600
Dead time setting for the third reclosing cycle for single-phase fault (See Chapter 1.2.3)						
REC79_1PhDT3_TPar_	3. Dead Time 1Ph	msec	10	100000	10	700
Dead time setting for the fourth reclosing cycle for single-phase fault (See Chapter 1.2.3)						
REC79_1PhDT4_TPar_	4. Dead Time 1Ph	msec	10	100000	10	800
Dead time setting for the first reclosing cycle for multi-phase fault (See Chapter 1.2.3)						
REC79_3PhDT1_TPar_1	1. Dead Time 3Ph	msec	0	100000	10	1000
Special dead time setting for the first reclosing cycle for multi-phase fault (See Chapter 1.2.4)						
REC79_3PhDT1_TPar_2	1. Special DT 3Ph	msec	0	100000	10	1350
Dead time setting for the second reclosing cycle for multi-phase fault (See Chapter 1.2.3)						
REC79_3PhDT2_TPar_	2. Dead Time 3Ph	msec	10	100000	10	2000
Dead time setting for the third reclosing cycle for multi-phase fault (See Chapter 1.2.3)						
REC79_3PhDT3_TPar_	3. Dead Time 3Ph	msec	10	100000	10	3000
Dead time setting for the fourth reclosing cycle for multi-phase fault (See Chapter 1.2.3)						
REC79_3PhDT4_TPar_	4. Dead Time 3Ph	msec	10	100000	10	4000
Reclaim time setting (See Chapter 1.2.11)						
REC79_Rec_TPar_	Reclaim Time	msec	100	100000	10	2000
Impulse duration setting for the CLOSE command (See Chapter 1.2.10)						
REC79_Close_TPar_	Close Command Time	msec	10	10000	10	100
Setting of the dynamic blocking time (See Chapter 1.2.17)						
REC79_DynBlk_TPar_	Dynamic Blocking Time	msec	10	100000	10	1500
Setting of the blocking time after manual close command						
REC79_MC_TPar_	Block after Man.Close	msec	0	100000	10	1000
Setting of the action time (See Chapter 1.2.15)						
REC79_Act_TPar_	Action Time	msec	0	20000	10	1000
Limitation of the starting signal (See Chapter 1.2.1)						
REC79_MaxSt_TPar_	Start Signal Max Time	msec	0	10000	10	1000
Maximum delaying the start of the dead-time counter (See Chapter 1.2.2)						
REC79_DtDel_TPar_	DeadTime Max Delay	msec	0	100000	10	3000
Waiting time for circuit breaker ready signal (See Chapter 1.2.7)						
REC79_CBTO_TPar_	CB Supervision Time	msec	10	100000	10	1000
Waiting time for synchronous state signal (See Chapter 1.2.8)						
REC79_SYN1_TPar_	SynCheck Max Time	msec	500	100000	10	10000
Waiting time for synchronous switching (See Chapter 1.2.9)						
REC79_SYN2_TPar_	SynSw Max Time	msec	500	100000	10	10000

Table 1-3 Timer parameters of the HV automatic reclosing function

Boolean parameters

Parameter name	Title	Default	Explanation
REC79_CBState_BPar_	CB State Monitoring	0	Enable CB state monitoring for “Not Ready” state (See Chapter 1.2.18)
REC79_3PhRecBlk_BPar_	Disable 3Ph Rec.	0	Disable three-phase reclosing (See Chapter 1.2.6)
REC79_Acc1_BPar_	Accelerate 1.Trip	0	Accelerate trip command starting cycle 1 (See Chapter 1.2.16)
REC79_Acc2_BPar_	Accelerate 2.Trip	0	Accelerate trip command starting cycle 2 (See Chapter 1.2.16)
REC79_Acc3_BPar_	Accelerate 3.Trip	0	Accelerate trip command starting cycle 3 (See Chapter 1.2.16)
REC79_Acc4_BPar_	Accelerate 4.Trip	0	Accelerate trip command starting cycle 4 (See Chapter 1.2.16)
REC79_Acc5_BPar_	Accelerate FinTrip	0	Accelerate final trip command (See Chapter 1.2.16)

Table 1-4 Boolean parameters of the HV automatic reclosing function

4.1.22.3.3. Summary of the generated output signals

The **binary output status signals** of the HV automatic reclosing function are listed in Table 1-5.

Binary output status signal	Title	Explanation
REC79_Blocked_Grl_	Blocked	The HV automatic reclosing function is in blocked state. (See Chapters 1.2.17 and 1.2.18)
REC79_Close_Grl_	Close command	Close command of the HV automatic reclosing function. (See Chapter 1.2.10)
REC79_CIReq_Grl_	CloseRequ. SynSwitch	The closing requests synchronous switching. (See Chapter 1.2.9)
REC79_FinTr_Grl_	Final Trip	Indication of final trip state. (See Chapter 1.2.14)
REC79_TrAcc_Grl_	Acceleration	Trip command acceleration. (See Chapter 1.2.16)
REC79_Run_Grl_	AR in progress	The automatic reclosing is running (“In progress” state).

Table 1-5 The binary output status signals of the HV automatic reclosing function

4.1.22.4. Examples

4.1.22.4.1. Logic connections of the REC79HV function block

Basic example for the application of the REC79HV function block in a logic diagram is shown in Figure 3-1. This connection is used for the examples below.

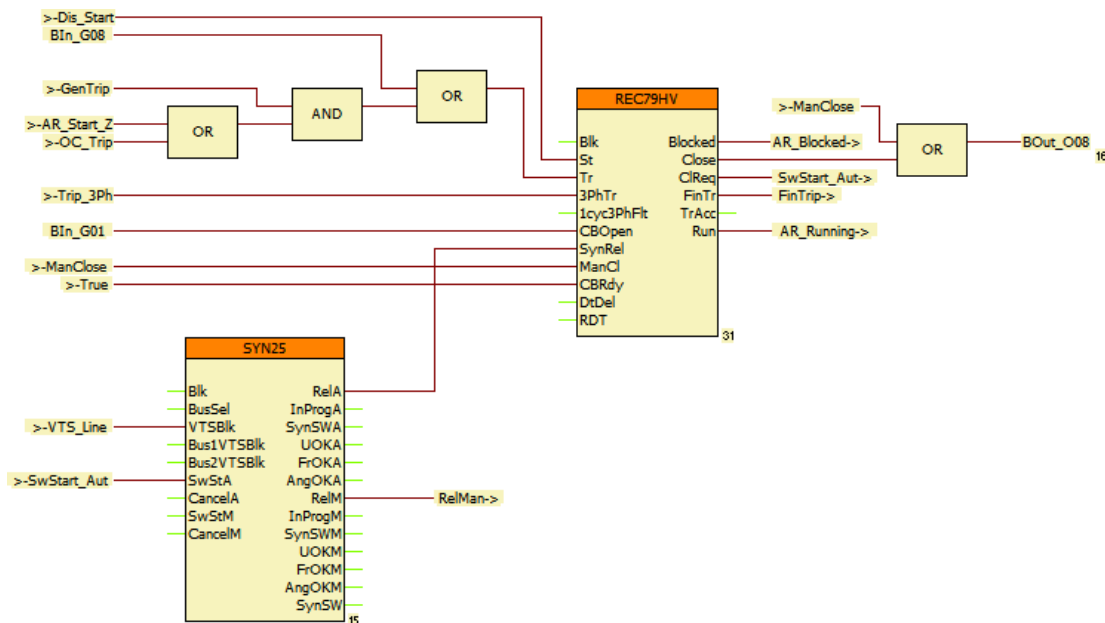

Figure 3-1 Example: The connections of the function block of the AR function

The “**Blk**” input is not connected. The function cannot be disabled externally.

The “**St**” input is connected the general start signal from the distance protection. This means that if the distance protection starts in any zone, the automatic reclosing function will wait for the trip signal to come on the “**Tr**” input (see Chapter 1.2.6).

The “**Tr**” input is connected to a binary input (e.g. external AR start signal) and to the trip signals of the distance and overcurrent protections. The AND connection of the “**GenTrip**” command prevents the starting if the “**Trip Logic**” function block (not shown here) disables the operation of the trip contacts.

The “**3PhTr**” input is connected to the three-phase trip command indicator of the “**Trip Logic**” function block.

The “**1cyc3PhFlt**” input is not connected. No special dead time is used in this configuration. The

“**CBOpen**” input is connected to the open state signal from the circuit breaker.

The “**SynRel**” input is connected to the release output of the synchro-check/synchro-switch function. This input disables the reclosing in case of asynchronous state of the voltage vectors.

The “**ManCl**” input is connected to a signal that indicates the manual close command.

The “**CBRdy**” input is connected to fix TRUE signal. The ready state of the circuit breaker is out of consideration.

The “**DtDel**” input is not connected. The dead time is not intended to be delayed externally. The

“**RDT**” input is not connected. The dead time is not intended to be reduced externally.

4.1.22.4.2. Example1: Time diagram with two reclosing shots (first unsuccessful, second successful)

The following timing diagram shows two reclosing cycles. The first cycle is unsuccessful, the second one is successful. The relevant parameter set of the HV autoreclosing operation are listed in the Table 3-1 below. The effect of this parameter set is shown in the first time diagram of Figure 3-2.

HV AutoReclosing	
Operation	On
Reclosing Cycles	1.2. Enabled
Reclosing Started by	CB open
CB State Monitoring	0

Table 3-1 Example 1, parameter setting

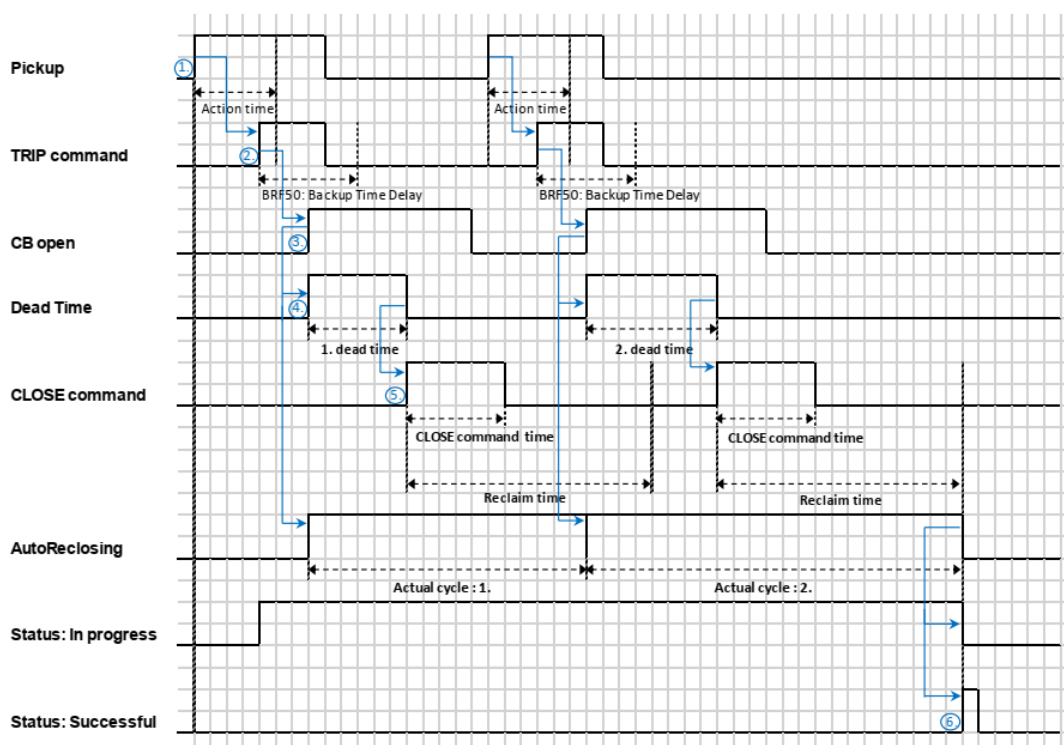
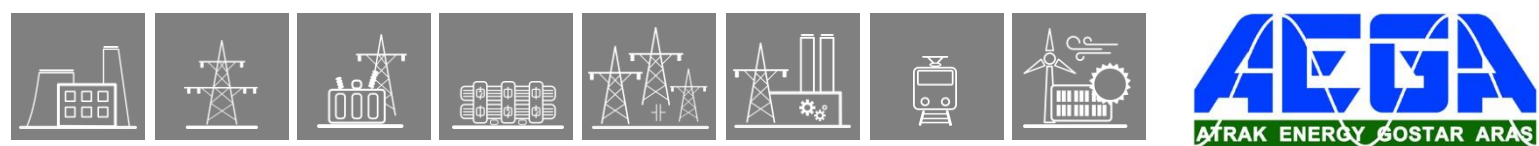

Figure 3-2 Example 1 time diagram

After a pickup of the protection function (No. 1), a timer starts to measure the “**Action time**” (the duration of which depends on parameter setting REC79_Act_TPar_ (Action time)). The trip command must be generated (No. 2) within this time to start reclosing cycles, or else the HV automatic function enters dynamic blocked state.

The automatic reclosing function is triggered if a protection function generates a trip command to the circuit breaker and the protection function resets because the fault current drops to zero and/or the auxiliary contact of the circuit breaker signals open state. Depending on the preset parameter value REC79_St_EPar_ (Reclosing started by), the HV automatic reclosing function can be started either by resetting of the TRIP command (setting: Trip reset) or by the binary signal indicating the open state of the circuit breaker (No. 3) (setting: CB open) – in the above example, the “Reclosing started by” parameter is set: “CB Open”.



According to the preset parameter values, either of these two conditions starts the timer for counting the „Dead time” (No. 4). For all four reclosing cycles, separate dead times can be defined for line-to-line faults and for earth faults.

At the end of the dead time the HV automatic reclosing function generates a close command automatically (No. 5). The **“Close command”** impulse is generated as one of the output status signals of the HV automatic reclosing function REC79_**Close**_GrI_ (Close command). This signal is common to all three phases. The impulse duration is defined by the user setting the timer parameter REC79_**Close**_TPar_ (Close command time).

When the close command is generated, a timer is started to measure the **“Reclaim time”**. The duration is defined by the parameter value REC79_**Rec**_TPar_ (Reclaim time), but it is prolonged up to the reset of the close command (if the close command duration is longer than the reclaim time set).

If the fault is detected again during this time, then the sequence of the HV automatic reclosing cycles continues, the above example showing this case. If no fault is detected, then at the expiry of the reclaim time the reclosing is evaluated as successful and the function resets. If a fault is detected after the expiry of this timer, then the cycles restart with the first reclosing cycle. (If the user programmed the status variable REC79_**St**_GrO_ (Protection Start) and it gets TRUE during the Reclaim time, then the HV automatic reclosing function continues even if the trip command is received after the expiry of the Reclaim time.)

After the second reclosing cycle no pickup is detected within the reclaim time, the HV auto reclosing function enters “Successful” state (No. 6). The HV automatic reclosing cycle resets and a new fault will start the procedure with the first cycle again.

4.1.22.4.3. Example2: Timing diagram with two reclosing shots (both unsuccessful)

The following timing diagram shows two unsuccessful reclosing cycles. The relevant parameter set of the HV autoreclosing is same like the previous case.

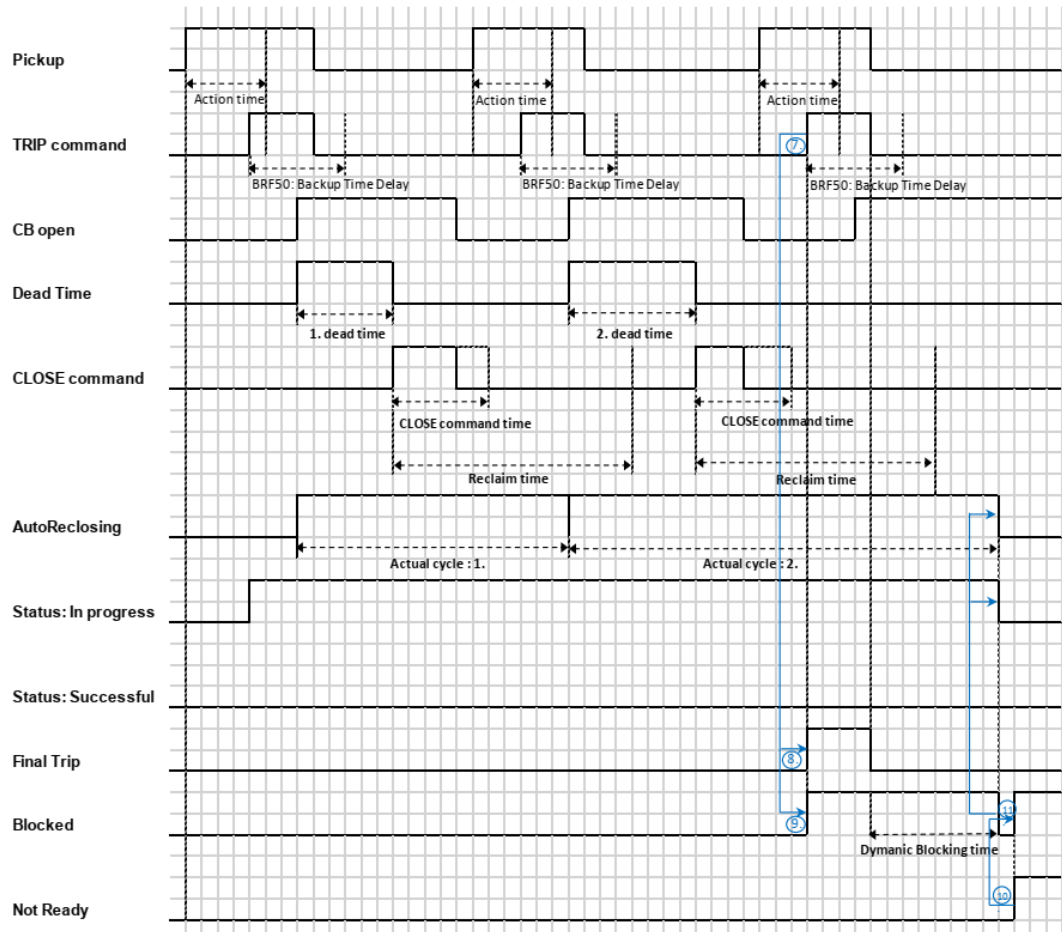

Figure 3-3 Example 2 time diagram

These events are similar to those of the previous case, but there are differences after the second reclosing attempt. The differences are written in the next Chapter.

The fault still exists at the end of the last cycle, therefore the protection function trips again (No. 7), and the HV automatic reclosing function trips and generates the signal for final trip: REC79_FinTr_Grl_ (Final Trip) (No. 8). After final trip, the HV automatic reclosing function enters “Dynamic blocked” state (No. 9). (A final trip command is also generated if a fault is detected again during the dead time.)

After the dynamic blocking, the HV automatic reclosing function gets “Not Ready” condition (No. 10), because the starting signal for automatic reclosing is selected by parameter REC79_St_EPar_ (Reclosing started by) to be “CB open” and the circuit breaker is in Open state and the “In progress” state of the function is not TRUE.

In a “Not ready” state, the REC79_Blocked_Grl_ (Blocked) status signal is TRUE, so the HV automatic reclosing function is blocked (No. 11).

4.1.22.4.4. Example3 Timing diagram with two reclosing shots (both unsuccessful)

The following timing diagram shows two unsuccessful reclosing cycles. The parameter setting of Table 3-2 are applied for the following timing diagram.

HV AutoReclosing	
Operation	On
Reclosing Cycles	1.2. Enabled
Reclosing Started by	Trip reset
CB State Monitoring	1
	⋮

Table 3-2 Example 3, parameter setting

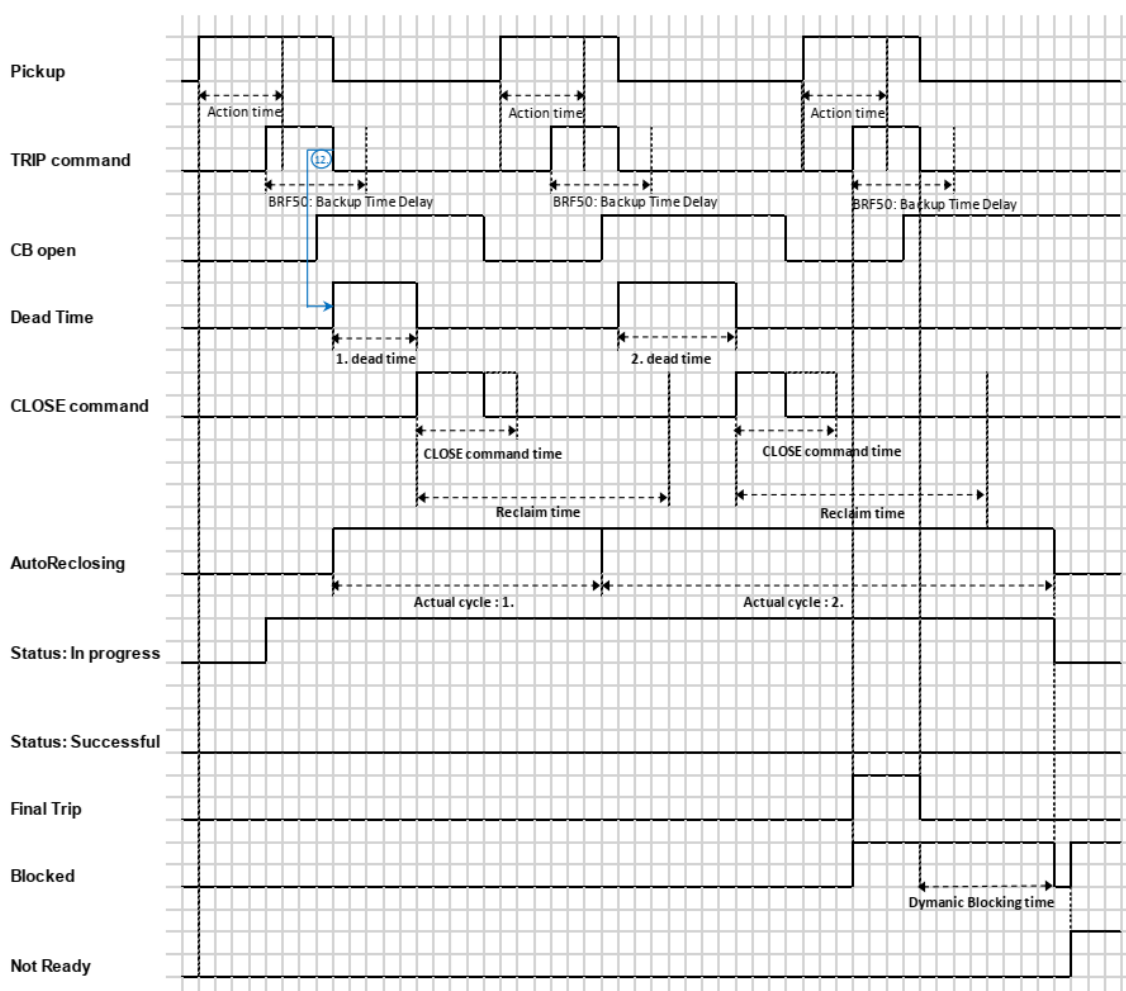

Figure 3-4 Example 3 time diagram

The timing diagram is similar to that of the previous case (Example2), the difference is caused by the starting of the HV automatic reclosing function. Here it is started by resetting of the TRIP command (setting: Trip reset) (No. 12).

4.1.22.4.5. Example4 Timing diagram with two reclosing shots (both unsuccessful)

The following timing diagram shows two unsuccessful reclosing cycles. The actual parameter set can be seen in the table below.

HV AutoReclosing	
Operation	On
Reclosing Cycles	1.2. Enabled
Reclosing Started by	Trip reset
CB State Monitoring	0
	⋮

Table 3-3 Example 4, parameter setting

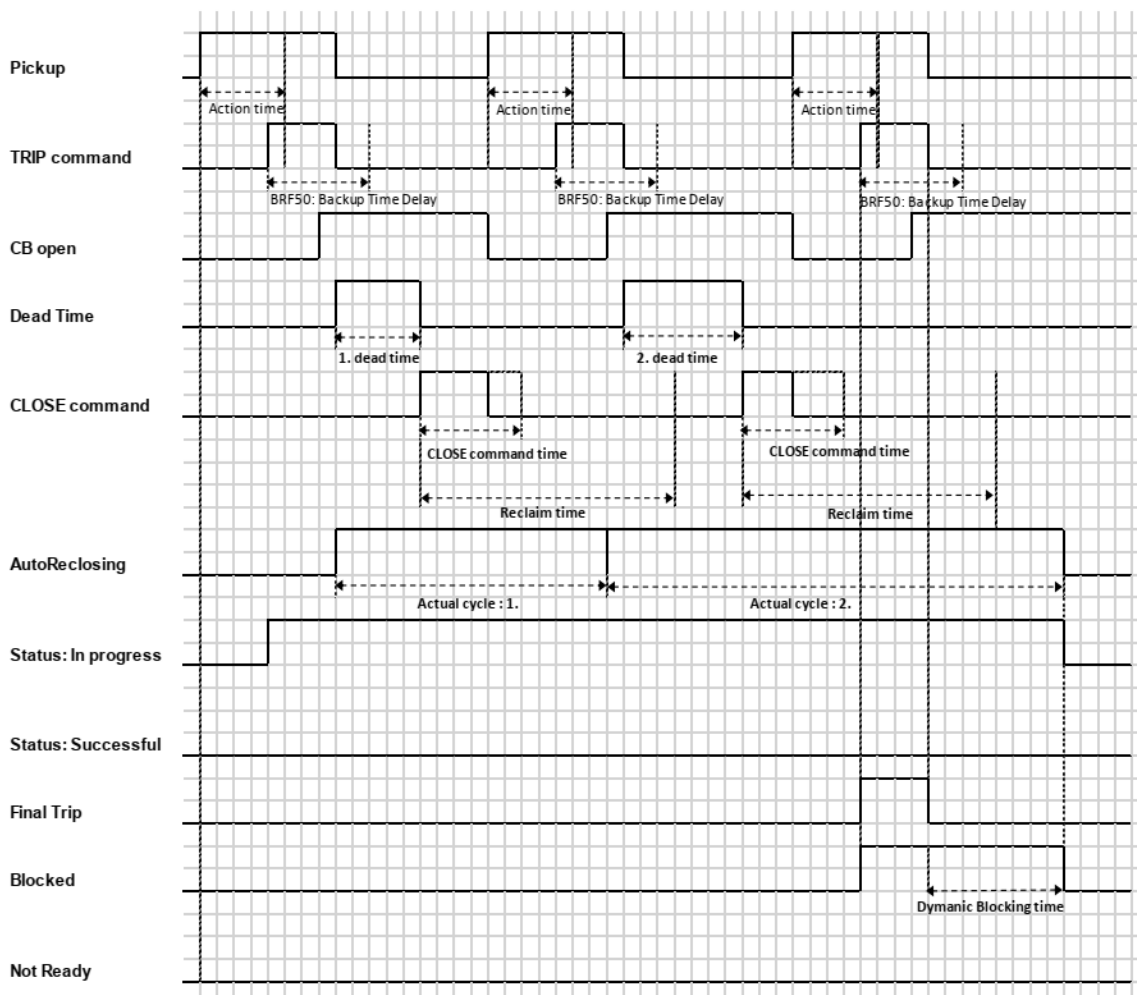

Figure 3-5 Example 4 time diagram

One difference can be seen if it is compared to the previous one.

After the "Dynamic Blocking" state the HV automatic reclosing function does not enter "Not Ready" state, because the "Not Ready" condition is not satisfied due to the parameter REC79_CBState_BPar_ (CB State Monitoring) is set to FALSE.

4.1.23.2. Overfrequency protection function overview

The graphic appearance of the function block of the overfrequency protection function is shown below. The block shows all binary input and output status signals which are applicable in the graphic equation editor.

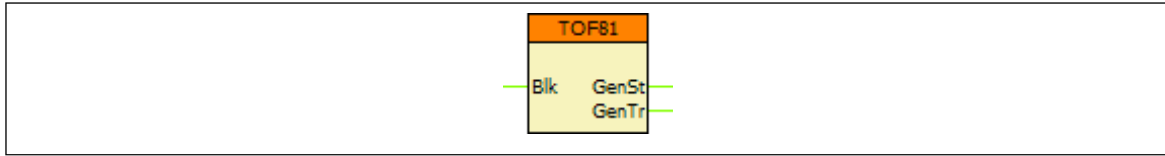

Figure 2-1 Graphic appearance of the function block of the overfrequency protection function

4.1.23.2.1. Settings

4.1.23.2.1.1. Parameters

The available parameters are listed below in order of their appearance in the *parameters* menu. If the setting range of a parameter should be extended, contact Protecta Support.

Table 2-1 Parameters of the overfrequency protection function

TITLE	DIM	RANGE	STEP	DEFAULT	EXPLANATION
Operation	-	Off, On	-	Off	Enabling the function
Start Signal Only	-	FALSE, TRUE	-	FALSE	Enabling start signal only
Start Frequency	Hz	40.00 – 70.00	0.01	51.00	Setting value of the comparison
U limit	-	0.1Un – 1Un	0.01	0.45	Minimum voltage condition for enabling the operation of the function
Time Delay	msec	140* – 10000	1	200	Time delay (including the algorithm time, see Chapter 2.4 for more explanation)

*The minimum operate time is lower than the settable minimum delay, however below this value the timing is less accurate, see Chapter 2.3 for details

4.1.23.2.2. Function I/O

This section describes briefly the analogue and digital inputs and outputs of the function block.

4.1.23.2.2.1. Analogue inputs

The function uses the sampled values of a voltage input or a calculated line-to-line voltage. This is defined in the configuration.

4.1.23.2.2.2. Analogue outputs (measurements)

The frequency measurement is displayed *MXU_F* – frequency measurement function which is an independent function.

4.1.23.2.2.3. Binary input signals (graphed output statuses)

The conditions of the binary inputs are defined by the user, applying the graphic equation editor (*Logic Editor*). Parts written in **bold** are seen on the left side function block in the Logic editor.

Table 2-2 The binary input signal of the overfrequency protection function

BINARY OUTPUT SIGNAL	EXPLANATION
TOF81_ Blk _GrO_	Blocking input of the function

4.1.23.2.2.4. Binary output signals (graphed input statuses)

These signals can be used in EuroCAP to assign to LED, user LCD object etc. Parts written in **bold** are seen on the right side of the function block in the *Logic Editor*.

Table 2-3 The binary output signals of the overfrequency protection function

BINARY OUTPUT SIGNAL	SIGNAL TITLE	EXPLANATION
TOF81_ GenSt _Grl_	General Start	General start signal of the function
TOF81_ GenTr _Grl_	General Trip	General trip command of the function

4.1.23.2.2.5. Online data

Visible values on the *online data* page.

Table 2-4 Online displayed data of the overfrequency protection function

SIGNAL TITLE	DIMENSION	EXPLANATION
General Start	-	General start signal of the function
General Trip	-	General trip command of the function

4.1.23.2.2.6. Events

The following events are generated in the event list, as well as sent to the SCADA according to the configuration.

Table 2-5 Generated events of the overfrequency protection function

EVENT	VALUE	EXPLANATION
General Start	off, on	General start of the function
General Trip	off, on	General trip command of the function

4.1.23.2.3. Technical data

The technical data, except for the min. operate voltage, are based on the function block testing according to the directives of the **IEC 60255-181:2019** standard.

Table 2-6 Technical data of the overfrequency protection function

FUNCTION	VALUE	ACCURACY
Operate range	40 - 60 Hz (50 Hz system) 50 - 70 Hz (60 Hz system)	± 3 mHz (20 mHz*)
Effective range	45 - 55 Hz (50 Hz) 55 - 65 Hz (60 Hz)	± 3 mHz (10 mHz*)
Min. operate time	93 ms (50 Hz) 73 ms (60 Hz)	± 32 ms ± 27 ms
Time delay	140 – 60000 ms <140 ms (50 Hz) <140 ms (60 Hz)	± 4 ms ± 32 ms ± 27 ms
Reset frequency	[Start freq.] – 101 mHz	± 1 mHz
Reset time	98 ms (50 Hz) 85 ms (60 Hz)	± 6 ms
Reset ratio for U limit	0.8	

**with the harmonic content according to the standard*

4.1.23.2.4. Notes for testing

Normally in the EuroProt+ devices the trip contacts are assigned to the Trip Logic function block, and not to the protection function blocks. Because of this, the testing personnel must make sure that the Trip Logic is switched on ('Operation' parameter is set to other than 'Off') before starting the tests, otherwise there will be no physical trip on the relay.

Note that the time delay parameter incorporates the algorithm time as well, so the time delay *does not mean the time difference between the appearance of the start and trip signals* of the function. In other words: it is not the delay between the detection of the fault and the trip that follows it. This should be taken into consideration when checking the disturbance records.

Instead the time delay parameter defines the elapsed time from the appearance of the faulty state to the trip. Because of this, while testing, the delay measurement should start *from the moment of the fault injection* until the trip signal.

The source voltage for frequency measurement is defined by the voltage input of the functionblock. This can be checked in the functionblock properties in EuroCAP

Before the fault injection at least 1 second pre-fault should be simulated with nominal frequency and voltage.

Based on IEC 60255-181 standard recommendations, the operation time shall be measured with a frequency of 0.5Hz higher than the setting value for Start frequency.

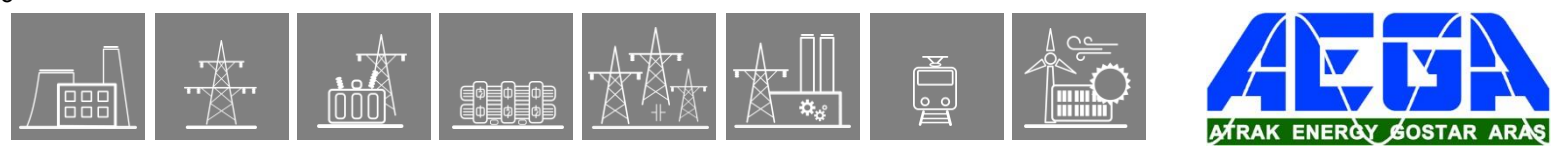

4.1.24. Underfrequency protection function

4.1.24.1. Application

The deviation of the frequency from the rated system frequency indicates unbalance between the generated power and the load demand. If the available generation is small compared to the consumption by the load connected to the power system, then the system frequency is below the rated value. The underfrequency protection function is usually applied to increase generation or for load shedding to control the system frequency.

Another possible application is the detection of unintended island operation of distributed generation and some consumers. In the island, there is low probability that the power generated is the same as the consumption; accordingly, the detection of low frequency can be one of the indications of island operation.

4.1.24.1.1. Mode of operation

Depending on the hardware-software configuration, the frequency measurement is usually based on channel No. 1 (line voltage) and channel No. 4 (busbar voltage) of any voltage input module.

The accurate frequency measurement is performed by measuring the time period between two rising edges and also between two falling edges at zero crossing of a voltage signal. The frequency value is calculated by the average of these two values. At each zero crossing the average value (and the frequency) is recalculated.

For the acceptance of the measured frequency, at least four subsequent valid measurements are needed. Similarly, four invalid measurements are needed to reset the measured frequency from the last valid value to zero.

The minimum voltage condition can be set as a parameter for enabling the evaluation of the frequency. This parameter is called U limit.

The underfrequency protection function generates a start signal if at least five measured frequency values are below the preset level.

4.1.24.2. Underfrequency protection function overview

The graphic appearance of the function block of the underfrequency protection function is shown below. The block shows all binary input and output status signals which are applicable in the graphic equation editor.

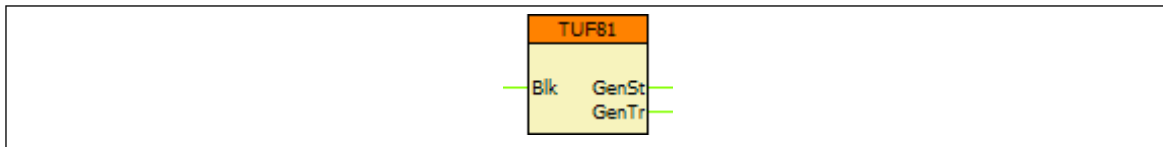

Figure 2-1 Graphic appearance of the function block of the underfrequency protection function

4.1.24.2.1. Settings

4.1.24.2.1.1. Parameters

The available parameters are listed below in order of their appearance in the *parameters* menu. If the setting range of a parameter should be extended, contact Protecta Support.

Table 2-1 Parameters of the underfrequency protection function

TITLE	DIM	RANGE	STEP	DEFAULT	EXPLANATION
Operation	-	Off, On	-	Off	Enabling the function
Start Signal Only	-	FALSE, TRUE	-	FALSE	Enabling start signal only
Start Frequency	Hz	40.00 – 70.00	0.01	49.00	Setting value of the comparison
U limit	-	0.1Un – 1Un	0.01	0.45	Minimum voltage condition for enabling the operation of the function
Time Delay	msec	140* – 10000	1	200	Time delay (including the algorithm time, see Chapter 2.4 for more explanation)

*The minimum operate time is lower than the settable minimum delay, however below this value the timing is less accurate, see Chapter [2.3](#) for details

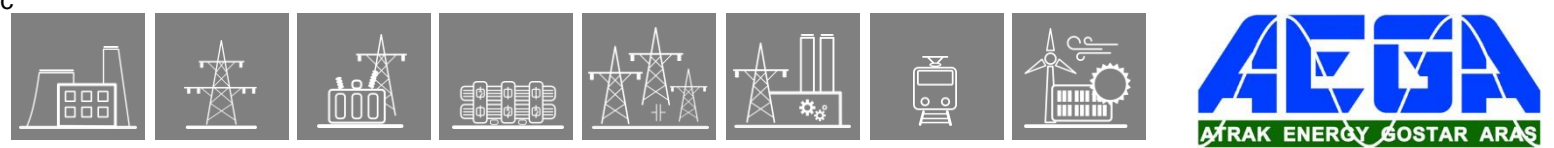

4.1.24.2.3. Technical data

The technical data, except for the min. operate voltage, are based on the function block testing according to the directives of the **IEC 60255-181:2019** standard.

Table 2-6 Technical data of the underfrequency protection function

FUNCTION	VALUE	ACCURACY
Operate range	40 - 60 Hz (50 Hz system) 50 - 70 Hz (60 Hz system)	± 3 mHz (20 mHz*)
Effective range	45 - 55 Hz (50 Hz) 55 - 65 Hz (60 Hz)	± 3 mHz (10 mHz*)
Min. operate time	93 ms (50 Hz) 73 ms (60 Hz)	± 32 ms ± 27 ms
Time delay	140 – 60000 ms <140 ms (50 Hz) <140 ms (60 Hz)	± 4 ms ± 32 ms ± 27 ms
Reset frequency	[Start freq.] + 101 mHz	± 1 mHz
Reset time	98 ms (50 Hz) 85 ms (60 Hz)	± 6 ms
Reset ratio for U limit	0.8	

**with the harmonic content according to the standard*

4.1.24.2.4. Notes for testing

Normally in the EuroProt+ devices the trip contacts are assigned to the Trip Logic function block, and not to the protection function blocks. Because of this, the testing personnel must make sure that the Trip Logic is switched on ('Operation' parameter is set to other than 'Off') before starting the tests, otherwise there will be no physical trip on the relay.

Note that the time delay parameter incorporates the algorithm time as well, so the time delay **does not mean the time difference between the appearance of the start and trip signals** of the function. In other words: it is not the delay between the detection of the fault and the trip that follows it. This should be taken into consideration when checking the disturbance records.

Instead the time delay parameter defines the elapsed time from the appearance of the faulty state to the trip. Because of this, while testing, the delay measurement should start *from the moment of the fault injection* until the trip signal.

The source voltage for frequency measurement is defined by the voltage input of the functionblock. This can be checked in the functionblock properties in EuroCAP.

Before the fault injection at least 1 second pre-fault should be simulated with nominal frequency and voltage.

Based on IEC 60255-181 standard recommendations, the operation time shall be measured with a frequency of 0.5Hz lower than the setting value for Start frequency.

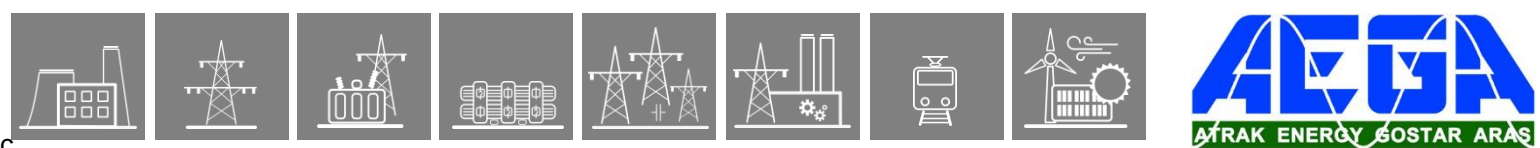

4.1.25. Rate of change of frequency protection function

4.1.25.1. Application

The deviation of the frequency from the rated system frequency indicates unbalance between the generated power and the load demand. If the available generation is large compared to the consumption by the load connected to the power system, then the system frequency is above the rated value, and if it is small, the frequency is below the rated value. If the unbalance is large, then the frequency changes rapidly. The rate of change of frequency protection function is usually applied to reset the balance between generation and consumption to control the system frequency.

Another possible application is the detection of unintended island operation of distributed generation and some consumers. In the island, there is low probability that the power generated is the same as consumption; accordingly, the detection of a high rate of change of frequency can be one of the indications of island operation.

4.1.25.1.1. Mode of operation

Depending on the hardware-software configuration, the frequency measurement is usually based on channel No. 1 (line voltage) and channel No. 4 (busbar voltage) of any voltage input module.

The accurate frequency measurement is performed by measuring the time period between two rising edges and also between two falling edges at zero crossing of a voltage signal. The frequency value is calculated by the average of these two values. At each zero crossing the average value (and the frequency) is recalculated.

For the acceptance of the measured frequency, at least four subsequent valid measurements are needed. Similarly, four invalid measurements are needed to reset the measured frequency from the last valid value to zero.

Other basic criterion is that the evaluated voltage should be above 10% of the rated voltage value.

The rate of change of frequency protection function generates a start signal if the df/dt value is above the setting value. The rate of change of frequency is calculated as the difference of the frequency at the present sampling and at 5 periods earlier; the df/dt comparator has a built-in delay of 100 ms to filter out unwanted operations.

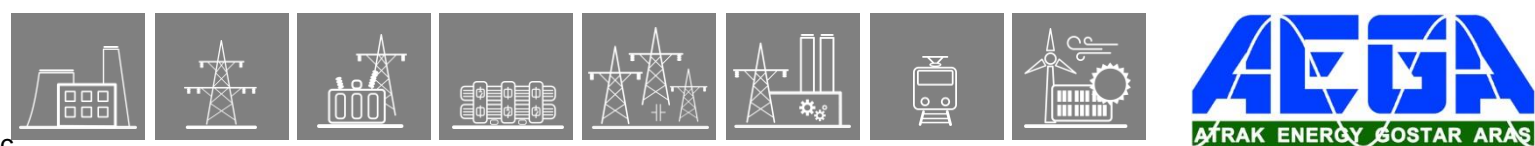

4.1.25.2.2. Function I/O

This section describes briefly the analogue and digital inputs and outputs of the function block.

4.1.25.2.2.1. Analogue inputs

The function uses the sampled values of a voltage input or a calculated line-to-line voltage. This is defined in the configuration.

4.1.25.2.2.2. Binary input signals (graphed output statuses)

The conditions of the binary inputs are defined by the user, applying the graphic equation editor (*Logic Editor*). Parts written in **bold** are seen on the left side function block in the *Logic editor*.

Table 2-2 The binary input signal of the rate of change of frequency protection function

BINARY OUTPUT SIGNAL	EXPLANATION
FRC81_ Blk _GrO_	Blocking input of the function

4.1.25.2.2.3. Binary output signals (graphed input statuses)

These signals can be used in EuroCAP to assign to LED, user LCD object etc. Parts written in **bold** are seen on the right side of the function block in the *Logic Editor*.

Table 2-3 The binary output signals of the rate of change of frequency protection function

BINARY OUTPUT SIGNAL	SIGNAL TITLE	EXPLANATION
FRC81_ GenSt _Grl_	General Start	General start signal of the function
FRC81_ GenTr _Grl_	General Trip	General trip command of the function

4.1.25.2.2.4. Online data

Visible values on the *online data* page.

Table 2-4 Online displayed data of the rate of change of frequency protection function

SIGNAL TITLE	DIMENSION	EXPLANATION
General Start	-	General start signal of the function
General Trip	-	General trip command of the function

4.1.25.2.2.5. Events

The following events are generated in the event list, as well as sent to the SCADA according to the configuration.

Table 2-5 Generated events of the rate of change of frequency protection function

EVENT	VALUE	EXPLANATION
General Start	off, on	General start of the function
General Trip	off, on	General trip command of the function

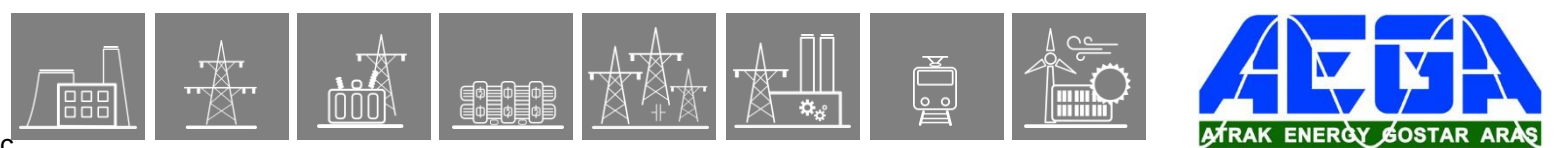

4.1.26. Teleprotection

4.1.26.1. Application

The non-unit protection functions, generally distance protection, can have two, three or even more zones available. These are usually arranged so that the shortest zone corresponds to an impedance slightly smaller than that of the protected section (underreach) and is normally instantaneous in operation. Zones with longer reach settings are normally time-delayed to achieve selectivity.

As a consequence of the underreach setting, faults near the ends of the line are cleared with a considerable time delay. To accelerate this kind of operation, protective devices at the line ends exchange logic signals (teleprotection). These signals can be direct trip command, permissive or blocking signals.

In some applications even the shortest zone corresponds to an impedance larger than that of the protected section (overreach). As a consequence of the overreach setting, faults outside the protected line would also cause an immediate trip command that is not selective. To prevent such unselective tripping, protective devices at the line ends exchange blocking logic signals.

The combination of the underreach – overreach settings with direct trip command, permissive or blocking signals facilitates several standard solutions, with the aim of accelerating the trip command while maintaining selectivity.

The teleprotection function block is pre-programmed for some of these modes of operation. The required solution is selected by parameter setting; the user has to assign the appropriate inputs by graphic programming.

Similarly, the user must assign the “send” signal to a relay output and to transmit it to the far end relay. The trip command is directed graphically to the appropriate input of the trip logic, which will energize the trip coil.

Depending on the selected mode of operation, the simple binary signal sent and received via a communication channel can have several meanings:

- Direct trip command
- Permissive signal
- Blocking signal

To increase the reliability of operation, in this implementation of the telecommunication function the sending end generates a signal, which can be transmitted via two different channels.

NOTE: the type of the communication channel is not considered here. It can be:

- Pilot wire
- Fiber optic channel
- High frequency signal over transmission line
- Radio or microwave
- Binary communication network
- Etc.

The function receives the binary signal via optically isolated inputs. It is assumed that the signal received through the communication channel is converted to a DC binary signal matching the binary input requirements.

4.1.26.1.1.1.1. Permissive Underreach Transfer Trip (PUTT) with Pickup (Start)

The protection system uses telecommunication, with underreach setting at each section end.

The signal is transmitted when a fault is detected by the underreach zone. The signal is prolonged by a drop-down timer.

Receipt of the signal at the other end initiates tripping in the local protection if it is in a started state.

Scheme of operation:

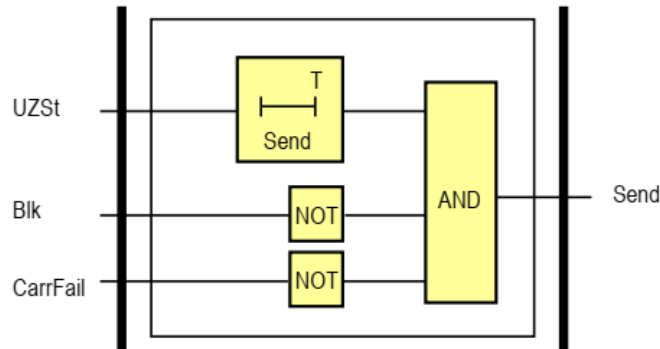

Fig. 1-1 Permissive Underreach Transfer Trip (PUTT) with Pickup (Start): Send signal generation

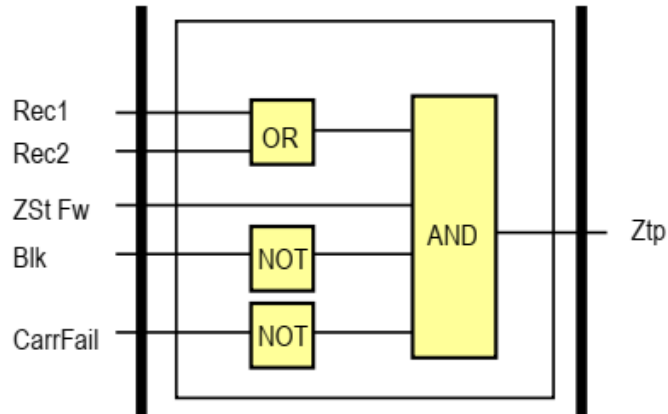
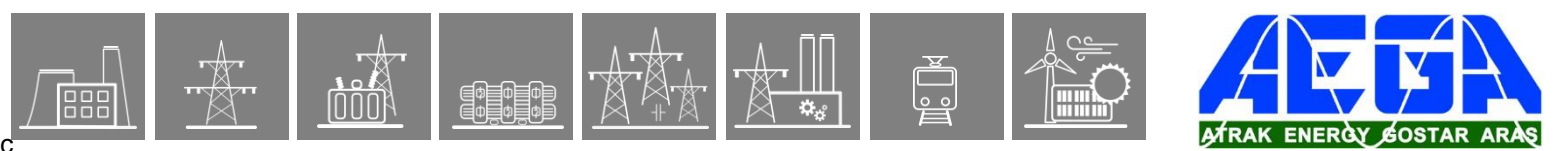

Fig. 1-2 Permissive Underreach Transfer Trip (PUTT) with Pickup (Start): Trip command generation



Required parameter setting:

Table 1-1 Enumerated parameters for PUTT with Pickup (Start)

ENUMERATED PARAMETER (TITLE)	EXPLANATION
Operation	PUTT
PUTT Trip	with Pickup (Start)

Table 1-2 Timer parameters for PUTT with Pickup (Start)

TIMER PARAMETER (TITLE)	REQUIRED SETTING
Send Prolong time	To be set as required
Direct Trip delay	-
Z Start delay (block)	-
Min. Block time	-
Prolong Block time	-

Table 1-3 Required input connections of the function block

FUNCTION BLOCK INPUT	REQUIRED SIGNAL
SCH85_Blk_GrO_ (Block)	Connect if blocking by a signal is needed
SCH85_CarFail_GrO_ (Carrier fail)	Connect if carrier failure signal is available
SCH85_Rec1_GrO_ (Received 1)	At least one of Received1/ Received 2 is to be connected
SCH85_Rec2_GrO_ (Received 2)	At least one of Received1/ Received 2 is to be connected
SCH85_ZStFw_GrO_ (Z Gen.start Fw)	To be connected
SCH85_ZStBw_GrO_ (Z Gen.start Bw)	-
SCH85_UZSt_GrO_ (Z Underreach Start)	To be connected
SCH85_OZSt_GrO_ (Z Overreach Start)	-
SCH85_GenTr_GrO_ (General Trip)	-

4.1.26.1.1.1.2. Permissive Underreach Transfer Trip (PUTT) with Overreach

The protection system uses telecommunication, with underreach setting at each section end.

The signal is transmitted when a fault is detected by the underreach zone. The signal is prolonged by a drop-down timer.

Receipt of the signal at the other end initiates tripping if the local overreaching zone detects fault.

Scheme of operation:

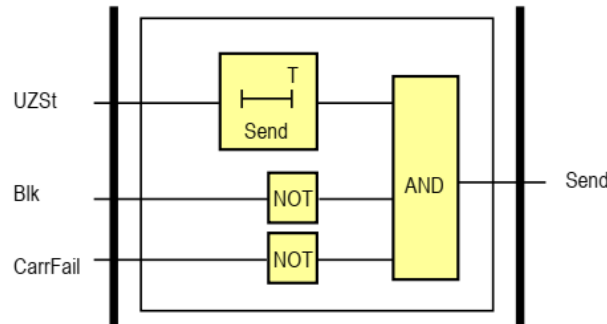

Fig. 1-3 Permissive Underreach Transfer Trip with Overreach: Send signal generation

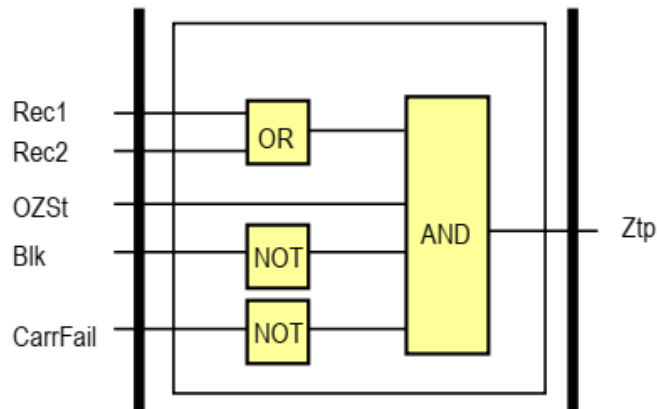
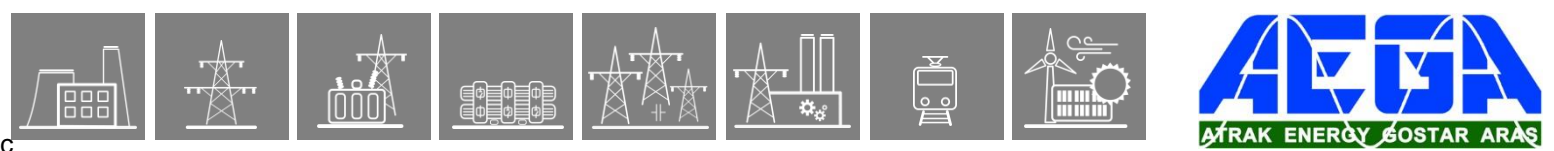

Fig. 1-4 Permissive Underreach Transfer Trip with Overreach: Trip command generation



Required parameter setting:

Table 1-4 Enumerated parameters for PUTT with Overreach

ENUMERATED PARAMETER (TITLE)	EXPLANATION
Operation	PUTT
PUTT Trip	with Overreach

Table 1-5 Timer parameters for PUTT with Overreach

TIMER PARAMETER (TITLE)	REQUIRED SETTING
Send Prolong time	To be set as required
Direct Trip delay	-
Z Start delay (block)	-
Min. Block time	-
Prolong Block time	-

Table 1-6 Required input connections of the function block

FUNCTION BLOCK INPUT	REQUIRED SIGNAL
SCH85_Blk_GrO_ (Block)	Connect if blocking by a signal is needed
SCH85_CarFail_GrO_ (Carrier fail)	Connect if carrier failure signal is available
SCH85_Rec1_GrO_ (Received 1)	At least one of Received1/ Received 2 is to be connected
SCH85_Rec2_GrO_ (Received 2)	At least one of Received1/ Received 2 is to be connected
SCH85_ZStFw_GrO_ (Z Gen.start Fw)	-
SCH85_ZStBw_GrO_ (Z Gen.start Bw)	-
SCH85_UZSt_GrO_ (Z Underreach Start)	To be connected
SCH85_OZSt_GrO_ (Z Overreach Start)	To be connected
SCH85_GenTr_GrO_ (General Trip)	-

4.1.26.1.1.2. Permissive Overreach Transfer Trip (POTT)

The IEC standard name of this mode of operation is Permissive Overreach Protection (POP).

The protection system uses telecommunication, with overreach setting at each section end. The signal is transmitted when a fault is detected by the overreach zone. This signal is prolonged if a general trip command is generated.

Receipt of the signal at the other end permits the initiation of tripping by the local overreach zone.

Scheme of operation:

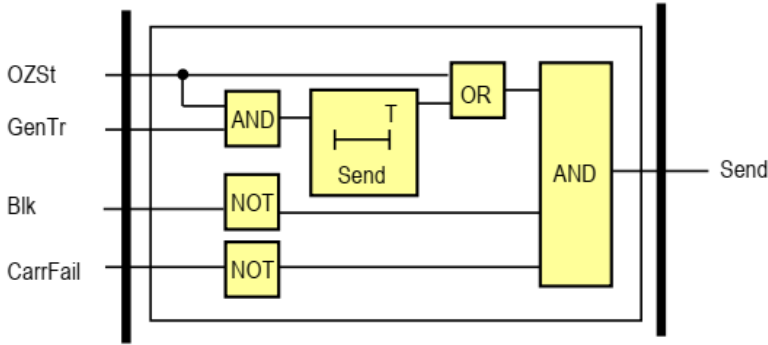

Fig. 1-5 Permissive Overreach Transfer Trip: Send signal generation

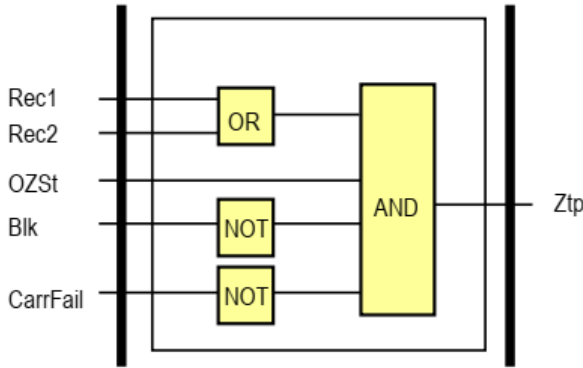
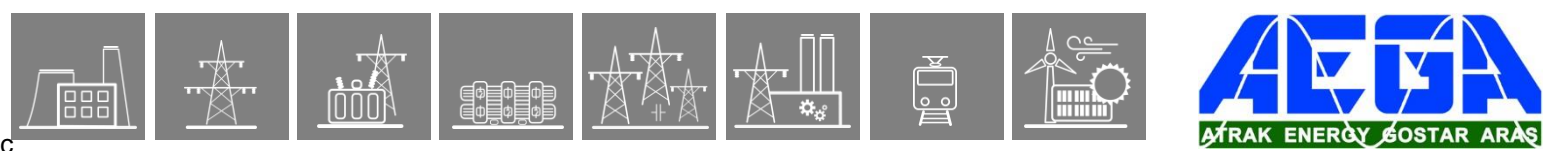

Fig. 1-6 Permissive Overreach Transfer Trip: Trip command generation



Required parameter setting:

Table 1-7 Enumerated parameters for POTT

ENUMERATED PARAMETER (TITLE)	REQUIRED SETTING
Operation	POTT
PUTT Trip	-

Table 1-8 Timer parameters for POTT

TIMER PARAMETER (TITLE)	REQUIRED SETTING
Send Prolong time	To be set as required
Direct Trip delay	-
Z Start delay (block)	-
Min. Block time	-
Prolong Block time	-

Table 1-9 Required input connections of the function block

FUNCTION BLOCK INPUT	REQUIRED SIGNAL
SCH85_Blk_GrO_ (Block)	Connect if blocking by a signal is needed
SCH85_CarFail_GrO_ (Carrier fail)	Connect if carrier failure signal is available
SCH85_Rec1_GrO_ (Received 1)	At least one of Received1/ Received 2 is to be connected
SCH85_Rec2_GrO_ (Received 2)	At least one of Received1/ Received 2 is to be connected
SCH85_ZStFw_GrO_ (Z Gen.start Fw)	-
SCH85_ZStBw_GrO_ (Z Gen.start Bw)	-
SCH85_UZSt_GrO_ (Z Underreach Start)	-
SCH85_OZSt_GrO_ (Z Overreach Start)	To be connected
SCH85_GenTr_GrO_ (General Trip)	To be connected

4.1.26.1.1.3. Directional comparison (Dir.Comparison)

The protection system uses telecommunication. The signal is transmitted when a fault is detected in forward direction. This signal is prolonged if a general trip command is generated.

Receipt of the signal at the other end permits the initiation of tripping by the local protection if it detected a fault in forward direction.

Scheme of operation:

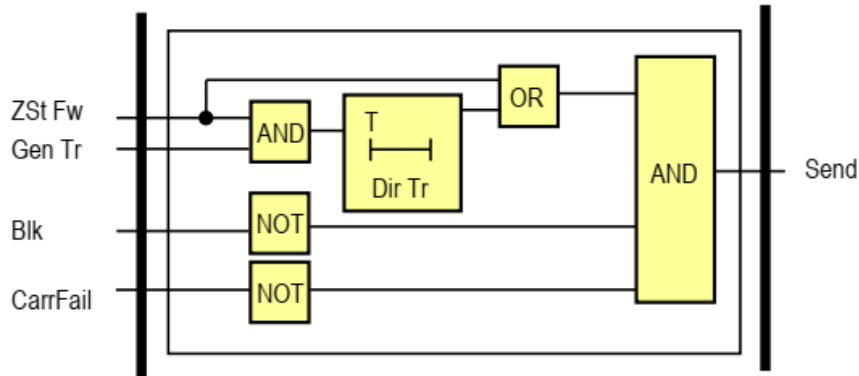

Fig. 1-7 Direction comparison: Send signal generation

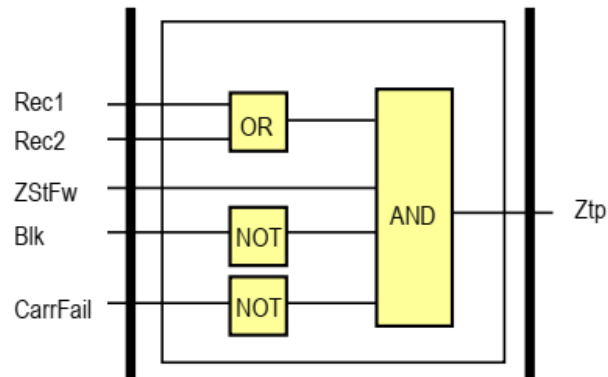
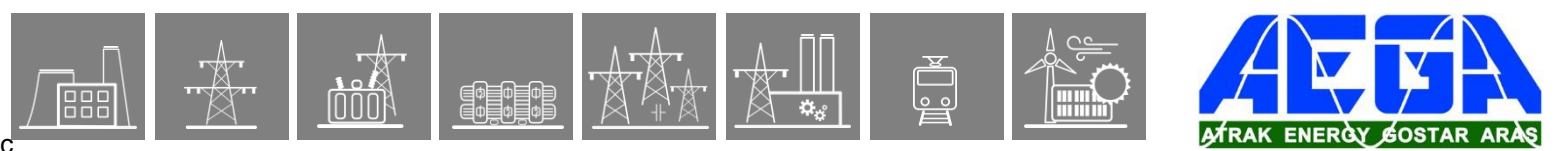

Fig. 1-8 Direction comparison: Trip command generation



Required parameter setting:

Table 1-10 Enumerated parameters for directional comparison

ENUMERATED PARAMETER (TITLE)	REQUIRED SETTING
Operation	Dir. comparison
PUTT Trip	-

Table 1-11 Timer parameters for directional comparison

TIMER PARAMETER (TITLE)	REQUIRED SETTING
Send Prolong time	To be set as required
Direct Trip delay	-
Z Start delay (block)	-
Min. Block time	-
Prolong Block time	-

Table 1-12 Required input connections of the function block:

FUNCTION BLOCK INPUT	REQUIRED SIGNAL
SCH85_Blk_GrO_ (Block)	Connect if blocking by a signal is needed
SCH85_CarFail_GrO_ (Carrier fail)	Connect if carrier failure signal is available
SCH85_Rec1_GrO_ (Received 1)	At least one of Received1/ Received 2 is to be connected
SCH85_Rec2_GrO_ (Received 2)	At least one of Received1/ Received 2 is to be connected
SCH85_ZStFw_GrO_ (Z Gen.start Fw)	To be connected
SCH85_ZStBw_GrO_ (Z Gen.start Bw)	-
SCH85_UZSt_GrO_ (Z Underreach Start)	-
SCH85_OZSt_GrO_ (Z Overreach Start)	-
SCH85_GenTr_GrO_ (General Trip)	To be connected

4.1.26.1.1.4. Blocking directional comparison (Dir.Blocking)

The IEC standard name of this mode of operation is Blocking Overreach Protection (BOP).

The protection system uses telecommunication, with overreach setting at each section end. The blocking signal is transmitted when a reverse external fault is detected. The signal is prolonged by a drop-down timer.

For the trip command, the forward fault detection is delayed to allow time for a blocking signal to be received from the opposite end.

Receipt of the signal at the other end blocks the initiation of tripping of the local protection.

The blocking signal received is prolonged if the duration of the received signal is shorter than the minimal duration and it is limited if it is longer than a specified maximal duration.

Scheme of operation:

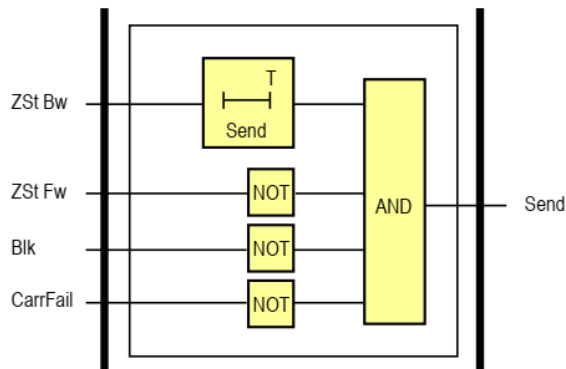

Fig. 1-9 Direction blocking: Send signal generation

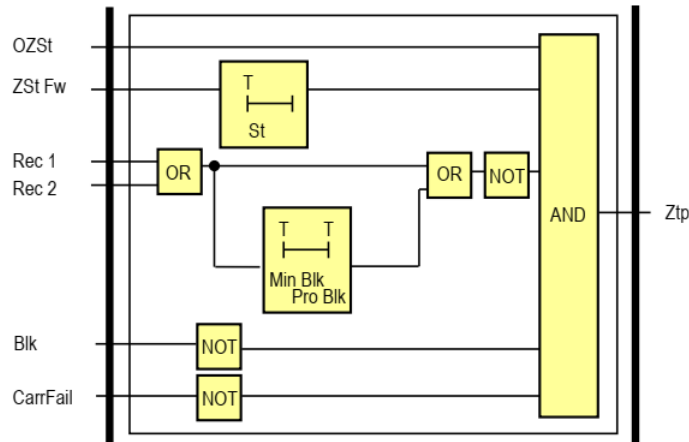
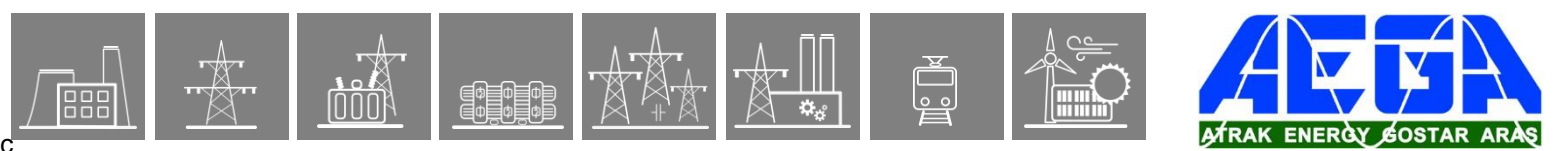

Fig. 1-10 Direction blocking: Trip command generation



Required parameter setting:

Table 1-13 Enumerated parameters for directional blocking

ENUMERATED PARAMETER (TITLE)	REQUIRED SETTING
Operation	Dir. blocking
PUTT Trip	-

Table 1-14 Timer parameters for directional blocking

TIMER PARAMETER (TITLE)	REQUIRED SETTING
Send Prolong time	To be set as required
Direct Trip delay	-
Z Start delay (block)	To be set as required
Min. Block time	To be set as required
Prolong Block time	To be set as required

Table 1-15 Required input connections of the function block

FUNCTION BLOCK INPUT	REQUIRED SIGNAL
SCH85_Blk_GrO_ (Block)	Connect if blocking by a signal is needed
SCH85_CarFail_GrO_ (Carrier fail)	Connect if carrier failure signal is available
SCH85_Rec1_GrO_ (Received 1)	At least one of Received1/ Received 2 is to be connected
SCH85_Rec2_GrO_ (Received 2)	At least one of Received1/ Received 2 is to be connected
SCH85_ZStFw_GrO_ (Z Gen.start Fw)	To be set as required
SCH85_ZStBw_GrO_ (Z Gen.start Bw)	To be set as required
SCH85_UZSt_GrO_ (Z Underreach Start)	-
SCH85_OZSt_GrO_ (Z Overreach Start)	To be set as required
SCH85_GenTr_GrO_ (General Trip)	-

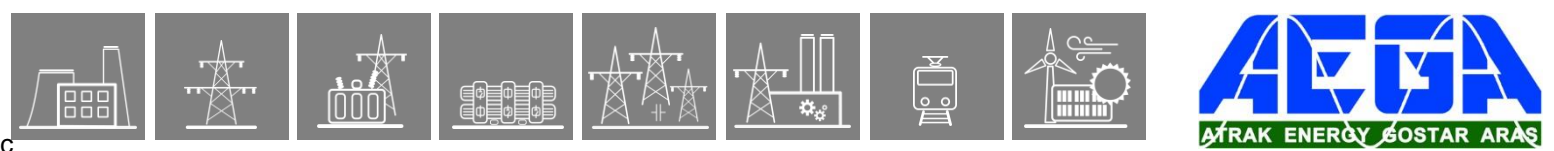

Required parameter setting:

Table 1-16 Enumerated parameters for DUTT

ENUMERATED PARAMETER (TITLE)	REQUIRED SETTING
Operation	DUTT
PUTT Trip	-

Table 1-17 Timer parameters for DUTT

TIMER PARAMETER (TITLE)	REQUIRED SETTING
Send Prolong time	To be set as required
Direct Trip delay	To be set as required
Z Start delay (block)	-
Min. Block time	-
Prolong Block time	-

Table 1-18 Required input connections of the function block

FUNCTION BLOCK INPUT	REQUIRED SIGNAL
SCH85_Blk_GrO_ (Block)	Connect if blocking by a signal is needed
SCH85_CarFail_GrO_ (Carrier fail)	Connect if carrier failure signal is available
SCH85_Rec1_GrO_ (Received 1)	At least one of Received1/ Received 2 is to be connected
SCH85_Rec2_GrO_ (Received 2)	At least one of Received1/ Received 2 is to be connected
SCH85_ZStFw_GrO_ (Z Gen.start Fw)	-
SCH85_ZStBw_GrO_ (Z Gen.start Bw)	-
SCH85_UZSt_GrO_ (Z Underreach Start)	To be connected
SCH85_OZSt_GrO_ (Z Overreach Start)	-
SCH85_GenTr_GrO_ (General Trip)	-

4.1.26.2. Teleprotection function overview

The function block of the teleprotection function is shown in Figure 2-1. This block shows all binary input and output status signals that are applicable in the graphic equation editor.

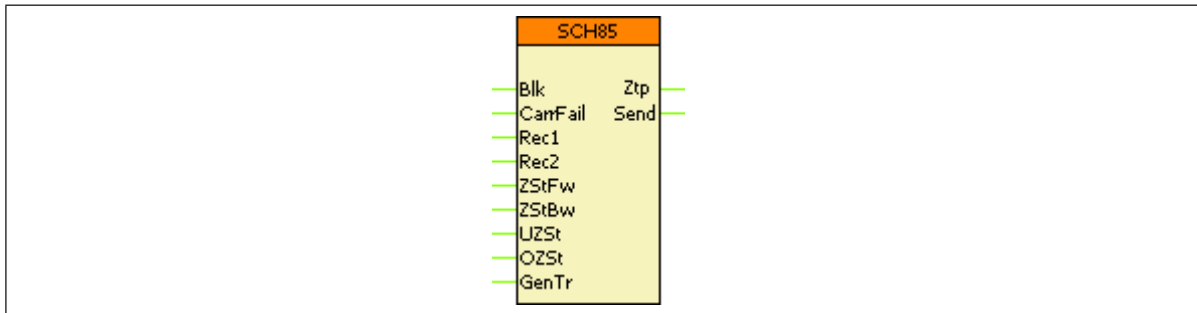

Figure 2-1 The function block of the teleprotection function

4.1.26.3. Settings

4.1.26.3.1. Parameters

The available parameters are listed below in order of their appearance in the *parameters* menu. If the setting range of a parameter should be extended, contact Protecta Support.

Table 2-1 Parameters of the teleprotection function

TITLE	DIM	RANGE	STEP	DEFAULT	EXPLANATION
Operation	-	Off, PUTT, POTT, Dir. comparison, Dir. blocking, DUTT	-	Off	Parameter for teleprotection type selection.
PUTT Trip	-	with Pickup, with Z Overreach	-	with Z Overreach	Parameter for PUTT type selection
Send Prolong time	msec	1 – 10000	1	10	Send signal prolong time
Direct Trip delay	msec	1 – 10000	1	10	Received direct trip delay time for DUTT
Z Start delay (block)	msec	1 – 10000	1	10	Forward fault detection delaying for Dir. Blocking
Min. Block time	msec	1 – 10000	1	10	Duration limit for Dir. Blocking
Prolong Block time	msec	1 – 10000	1	10	Prolong duration for Dir. Blocking

4.1.26.4. Function I/O

This section briefly describes the analogue and digital inputs and outputs of the function block.

4.1.26.4.1. Analogue inputs

There are no analogue inputs for this function block.

4.1.26.4.2. Binary input signals (graphed output statuses)

The conditions of the binary inputs are defined by the user, applying the graphic equation editor (*Logic Editor*). Parts written in **bold** are seen on the left side function block in the Logic editor.

Table 2-2 The binary input signals of the teleprotection function

BINARY INPUT SIGNAL	SIGNAL TITLE	EXPLANATION
SCH85_ Blk _GrO_	Block	Blocking input of the function
SCH85_ CarFail _GrO_	Carrier fail	Signal indicating failure of the communication channel
SCH85_ Rec1 _GrO_	Receive opp.1	Signal1 received from the opposite end
SCH85_ Rec2 _GrO_	Receive opp.2	Signal2 received from the opposite end
SCH85_ ZStFw _GrO_	Z Gen.start Fw	Protection start in forward direction
SCH85_ UZSt _GrO_	Z Underreach Start	Start of the underreaching zone (e.g. Z1)
SCH85_ OZSt _GrO_	Z Overreach Start	Start of the overreaching zone (e.g. Z2)
SCH85_ GenTr _GrO_	General Trip	General protection trip
SCH85_ ZStBw _GrO_	Z Gen.start Bw	Protection start in backward direction

4.1.26.4.3. Binary output signals (graphed input statuses)

These signals can be used in EuroCAP to assign to LED, user LCD object etc. Parts written in **bold** are seen on the right side of the function block in the *Logic Editor*.

Table 2-3 The binary output signals of the teleprotection function

BINARY OUTPUT SIGNAL	SIGNAL TITLE	EXPLANATION
SCH85_ Ztp _Grl_	Z Teleprot. Trip	Teleprotection trip command.
SCH85_ Send _Grl_	Send signal	Teleprotection signal to be transmitted from the local relay to the far end

4.1.26.4.4. Online data

There are no online data for this function block.

4.1.26.4.5. Events

The following events are generated in the event list, as well as sent to the SCADA according to the configuration.

Table 2-4 Generated events of the teleprotection function

EVENT	VALUE	EXPLANATION
Receive signal 1	off, on	Signal1 received from the opposite end
Receive signal 2	off, on	Signal2 received from the opposite end
Teleprot. Trip	off, on	Teleprotection trip command.
Send signal	off, on	Teleprotection signal transmitted from the local relay to the far end
Carrier Failed	off, on	Signal indicating the failure of the communication channel

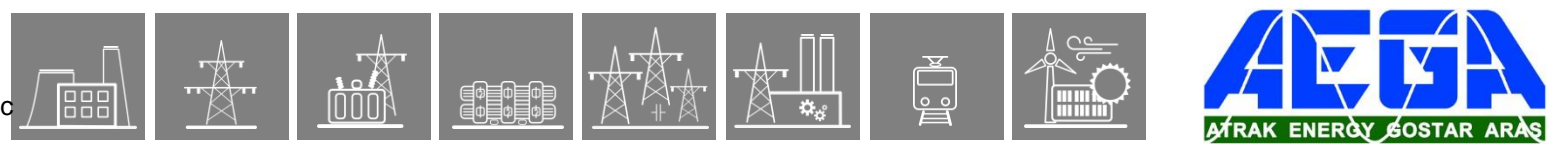

4.1.26.5. Technical data

Table 2-5 Technical data of the teleprotection function

FUNCTION	ACCURACY
Operate time accuracy	$\pm 5\%$ or ± 15 ms, whichever is greater

4.1.26.6. Notes for testing

As the function works always in connection with other function blocks, their settings must be checked as well, e.g. the corresponding Zone of the Distance protection (DIS21) is enabled, the Trip Logic (TRC94) is enabled etc.

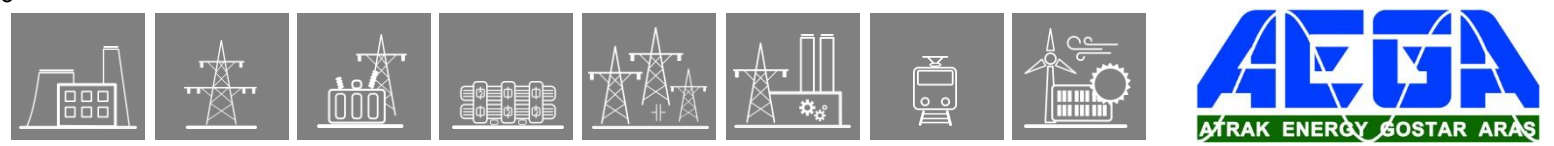

The **inputs** are

- the Fourier base component values of three phase currents at the local line end,
- the Fourier base component values of three phase currents received from the remote end,
- parameters,
- status signals.

The **outputs** are

- the binary output status signals,
- the measured values for displaying.

The **software modules** of the line differential protection function:

Differential current calculation

This module calculates the differential current for phases L1, L2 and L3 separately, based on the basic Fourier components of the six line currents.

Bias current calculation

This module calculates the restraint current common to phases L1, L2 and L3, based on the basic Fourier components of the six line currents.

Differential characteristics

This module compares the points defined by the differential currents in phases L1, L2 and L3 separately and the restraint current with the differential characteristic, defined by parameter setting. The high-speed overcurrent protection function based on the line differential currents is also performed in this module.

Decision logic

The decision logic module decides if a general trip command is to be generated.

The following description explains the details of the individual components.

4.1.27.1.2. The communication modules

These modules send/receive the calculated base harmonic Fourier vectors to/from the remote end.

The exact hardware module applied depends on the required communication interface: it can be either an additional fiber optic connector on the CPU module, or an independent COM module (for other types of connections or 3-ends line differential applications).



For the correct operation of the line differential protection function, the parameters for the communication modules must be set. Depending on the used module, these parameters can be found among the parameters either under the CPU LDC module function block or the COM module function block. Guide to their setting is described in the application guide mentioned above.

4.1.27.1.5. The evaluation of the differential characteristics (Differential characteristics)

4.1.27.1.5.1. The principle of the restrained differential characteristics

Based on the values of the restraint current magnitudes (denoted generally as “Ibias”) and the values of the differential current magnitudes (denoted generally as “Idiff”) the line differential protection characteristics are shown in Figure 1-2.

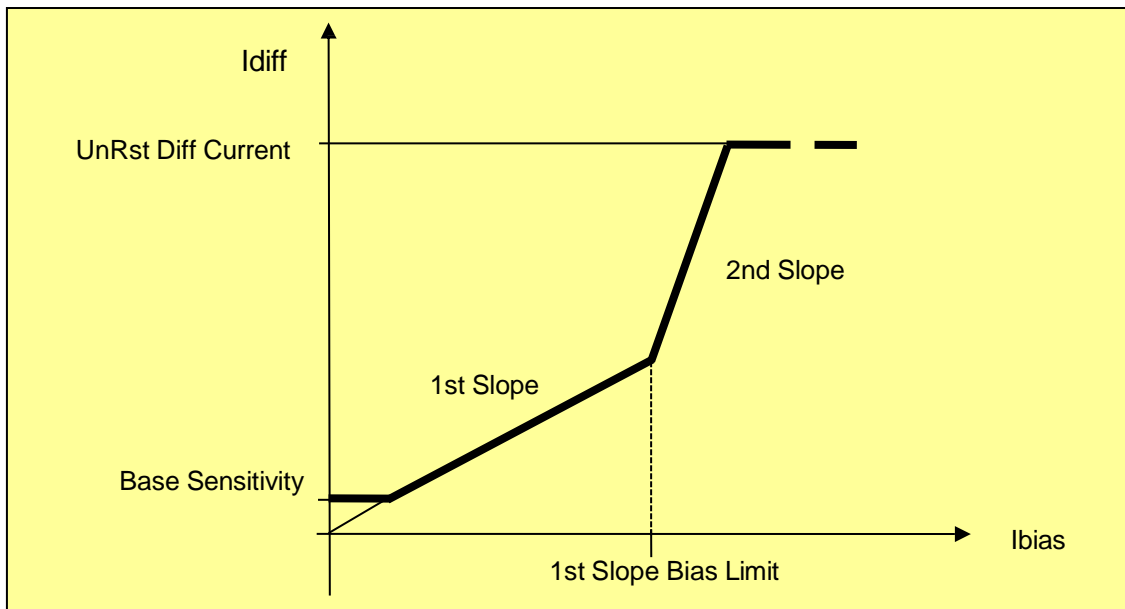

Figure 1-2 The differential protection characteristics

Additionally, separate status-signals are set to “true” value if the differential currents in the individual phases are above a limit, set by parameter (see “Unrestrained differential function”).

Integer parameters

Table 1-2 The integer parameters of the differential protection characteristics

Parameter name	Title	Unit	Min	Max	Step	Default
Base sensitivity:						
DIFF87L_Base_IPar_	Base Sensitivity	%*	10	50	1	30
Slope of the second section of the characteristics:						
DIFF87L_Slope1_IPar_	1st Slope	%**	10	50	1	30
Slope of the third section of the characteristics:						
DIFF87L_Slope2_IPar_	2nd Slope	%**	50	100	1	70
Bias limit for the 1st slope:						
DIFF87L_BiasLim_IPar_	1st Slope Bias Limit	%*	100	400	1	200
Unrestrained line differential protection current level:						
DIFF87L_HCurr_IPar_	Unrestrained Diff Current	%*	500	1500	1	800

*% related to the selected reference current “Iref” (see Chapter 1.3)

**% related to the bias current

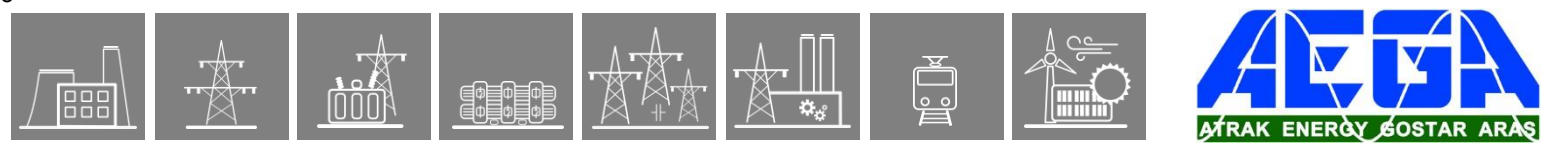

The following internal binary status signals are passed on to the decision logic.

Table 1-3 The internal binary output status signals of the restrained an unrestrained differential protection characteristics

Binary output signals	Signal title	Explanation
Differential characteristics		
DIFF87L_L1St_GrI_i	Start L1	This status is true if the differential current in phase R at the restraint current is above the characteristic lines
DIFF87L_L2St_GrI_i	Start L2	This status is true if the differential current in phase S at the restraint current is above the characteristic lines
DIFF87L_L3St_GrI_i	Start L3	This status is true if the differential current in phase T at the restraint current is above the characteristic lines
Unrestrained decision		
DIFF87L_UnRL1St_GrI_i	Start L1 unrestr.	This status is true if the differential current in phase R is above the high current setting
DIFF87L_UnRL2St_GrI_i	Start L1 unrestr.	This status is true if the differential current in phase S is above the high current setting
DIFF87L_UnRL3St_GrI_i	Start L1 unrestr.	This status is true if the differential current in phase T is above the high current setting

4.1.27.1.6. The decision logic (Decision logic)

4.1.27.1.6.1. The principle of the decision logic

The decision logic combines the following binary signals:

- Restrained and unrestrained start signals of the differential characteristic module
- Disabling status signals defined by the user, using graphic equation editor
DIFF87L_Blk_GrO

Blocking input signals

The differential protection function has a binary input signal, which serves disabling the function. **The conditions of disabling are defined by the user, applying the graphic equation editor for the signals.**

Table 1-4 The blocking input status signal of the decision logic

Binary input signal	Explanation
DIFF87_Blk_GrO_	Output status of a graphic equation to disable the differential protection function.

The binary output signals are listed in Table 1-5 below.

Table 1-5 The binary output status signals of the differential protection characteristics

Binary output signals	Signal title	Explanation
Differential characteristics		
DIFF87L_TrL1_Grl_	Trip L1	This status is true if the differential current in measuring element L1 at the restraint current is above the characteristic lines and the function is not blocked
DIFF87L_TrL2_Grl_	Trip L2	This status is true if the differential current in measuring element L2 at the restraint current is above the characteristic lines and the function is not blocked
DIFF87L_TrL3_Grl_	Trip L3	This status is true if the differential current in measuring element L3 at the restraint current is above the characteristic lines and the function is not blocked
DIFF87L_GenTr_Grl_	Trip	This status is true if the differential current in any measuring element at the restraint current is above the restrained characteristic lines and the function is not blocked

The GenTr signal is processed by the trip logic of the device, see the figure below.

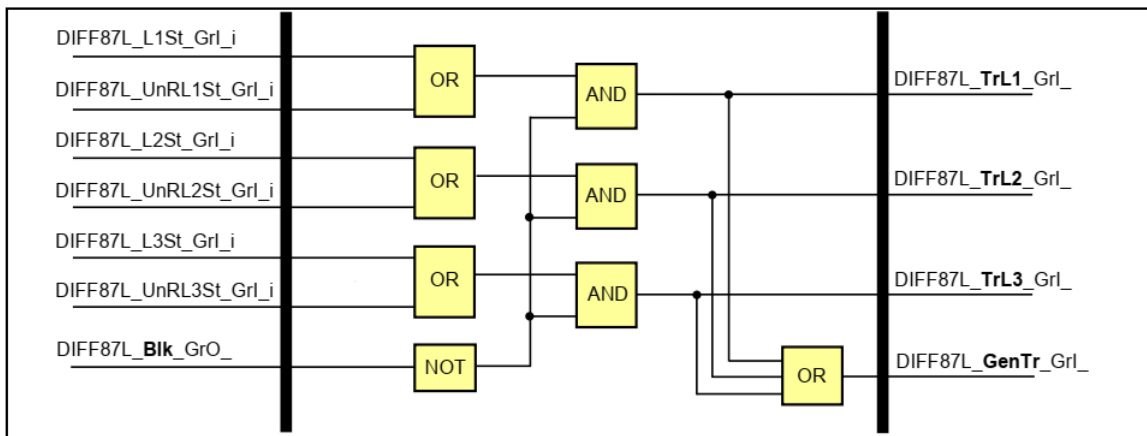

Figure 1-3 The decision logic schema of the line differential protection function

4.1.27.2. Line differential protection function overview

The graphic appearance of the function block of the line differential protection function with transformer in the protected zone is shown on Figure 2-1. The block shows all binary input and output status signals which are applicable in the graphic equation editor.

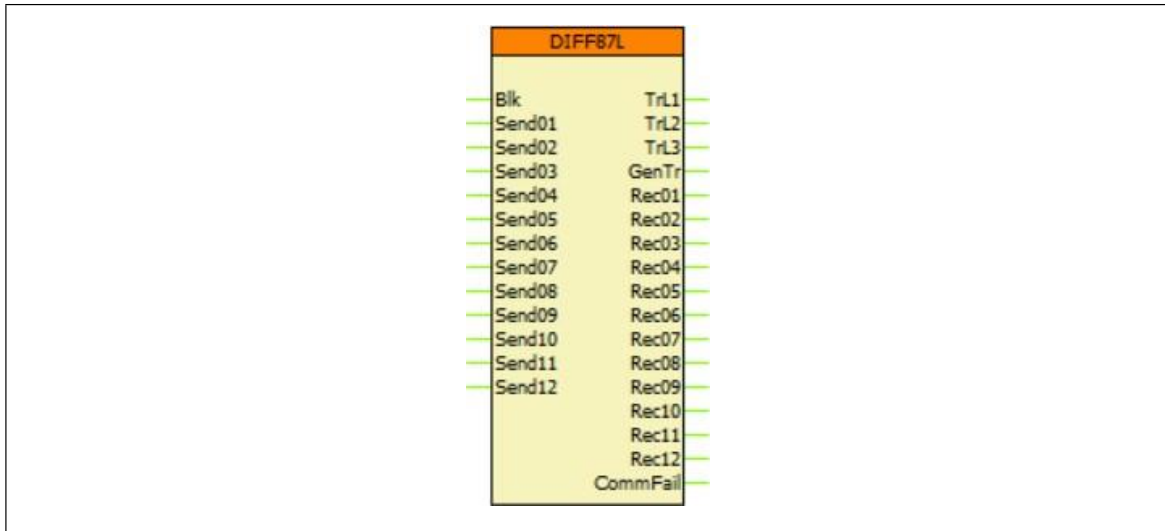

Figure 2-1 Graphic appearance of the function block of the line differential protection function for two ends

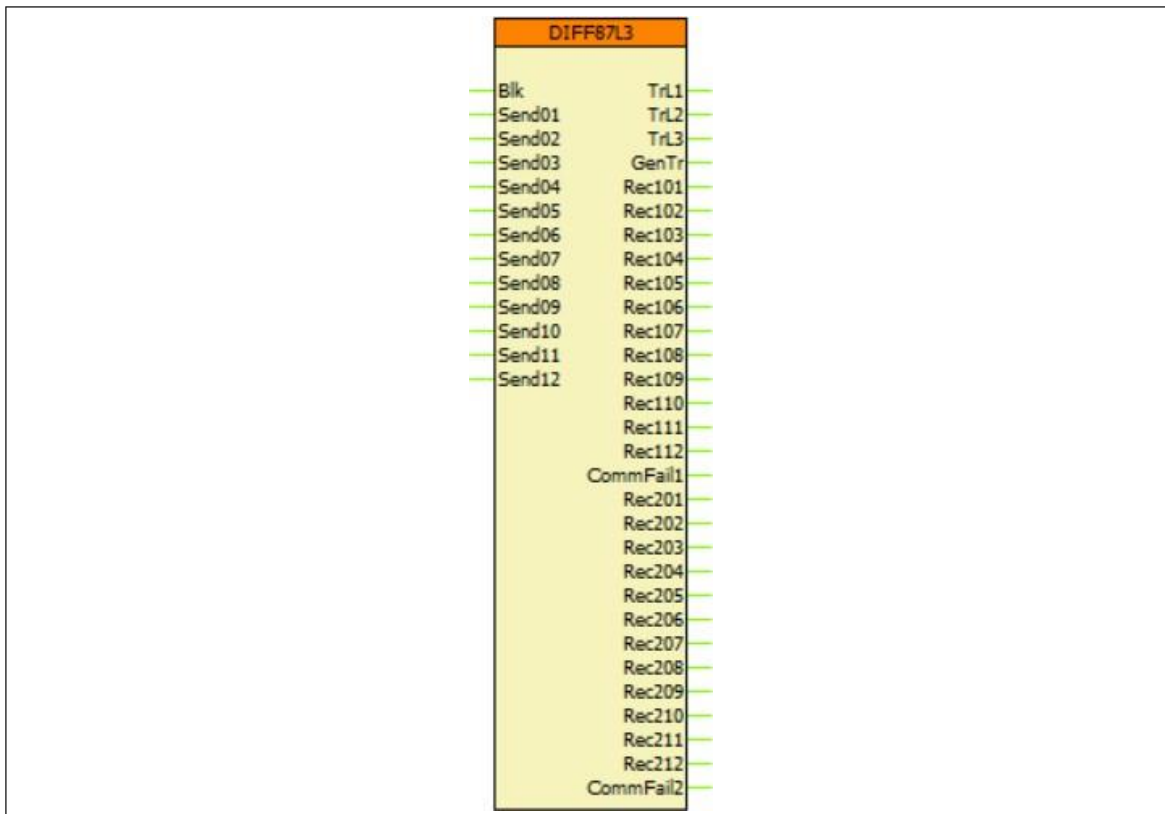
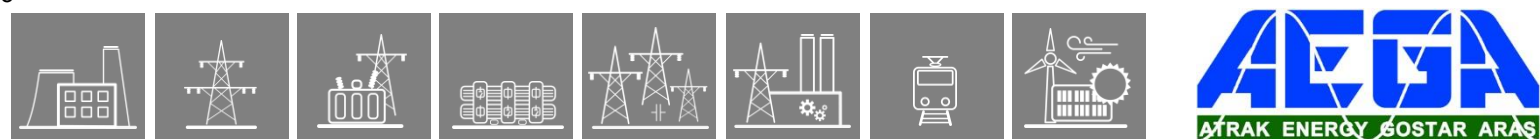

Figure 2-2 Graphic appearance of the function blocks of the line differential protection function with 3 ends (or redundant communication)



4.1.27.2.1. Settings

4.1.27.2.1.1. Parameters

Table 2-1 Parameters of the line differential protection function

TITLE	DIM	RANGE	STEP	DEFAULT	EXPLANATION
Operation	-	Off, On	-	Off	Enabling the line differential protection function
Operation*	-	Off, On_2end, On_Redu_2end, On_3end	-	Off	Operation modes of the two-channel line differential protection function*
<i>Parameters related to the current transformers</i>					
Local ratio	%	20 – 500	1	100	Current magnitude compensation related to the CT rated current
Remote ratio	%	20 – 500	1	100	Current magnitude compensation related to the CT rated current
Remote1 ratio*	%	20 – 500	1	100	Current magnitude compensation related to the CT rated current (first line)*
Remote2 ratio*	%	20 – 500	1	100	Current magnitude compensation related to the CT rated current (second line)*
<i>Parameters related to the differential characteristic</i>					
Base Sensitivity	% (In)	10 – 50	1	30	Base sensitivity - 1st section of the characteristic curve related to the magnitude-compensated current
1st Slope	% (Ibias)	10 – 50	1	30	1st Slope - 2nd section of the characteristic curve related to the bias current
2nd Slope	% (Ibias)	50 – 100	1	200	2nd Slope - 3rd section of the characteristic curve related to the bias current
1st Slope Bias Limit	% (In)	100 – 400	1	200	Bias current limit of the 1st slope (2nd section) of the characteristic curve related to the magnitude-compensated current
Unrestrained Diff Current	% (In)	500 – 1500	1	800	Unrestrained differential current - 4th section of the characteristic curve related to the magnitude-compensated current

*these parameters are available only for the optional two-channel variant of the function

4.1.27.2.1.2. Characteristics

The function uses a 2-slope characteristic with unrestrained section, see Figure 2-3.

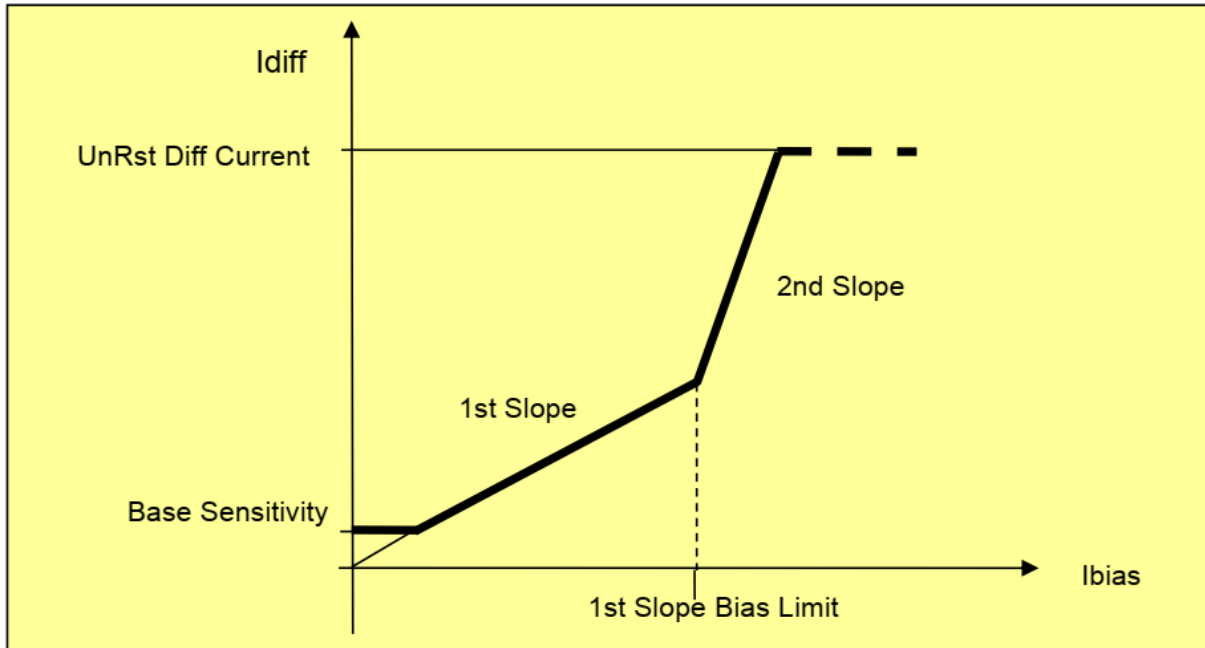
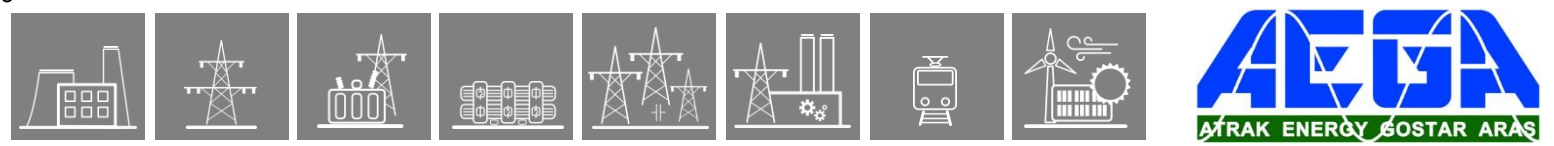

Figure 2-3 The line differential protection characteristics



4.1.27.2.2. Function I/O

This section describes briefly the analogue and digital inputs and outputs of the function block.

4.1.27.2.2.1. Analogue inputs

The function uses the following analogue signals as inputs:

- Sampled values of the local three phase currents
- Fourier components of the local three phase currents
- Sampled values of the remote three phase currents
- Basic Fourier component of the remote three phase currents

4.1.27.2.2.2. Analogue outputs (measurements)

The measured values of the differential protection function are listed in the table below.

Table 2-2 The measured analogue values of the line differential protection function

MEASURED VALUE	DIMENSION	EXPLANATION
Differential current L1	In %	The calculated differential current in measuring element L1 (after vector group compensation)
Differential current L2	In %	The calculated differential current in measuring element L2 (after vector group compensation)
Differential current L3	In %	The calculated differential current in measuring element L3 (after vector group compensation)
Bias current	In %	The calculated restraint current

4.1.27.2.2.3. Binary input signals (graphed output statuses)

The conditions of the inputs are defined by the user, applying the graphic equation editor (logic editor). The part written in **bold** is seen on the function block in the logic editor.

Table 2-3 The binary input signals of the line differential protection function

BINARY INPUT SIGNAL	EXPLANATION
DIFF87L_ Blk _GrO_	Output status of a graphic equation defined by the user to disable the differential protection function.
DIFF87L_ Send01 _GrO_	Free configurable signal to be sent via communication channel
DIFF87L_ Send02 _GrO_	Free configurable signal to be sent via communication channel
DIFF87L_ Send03 _GrO_	Free configurable signal to be sent via communication channel
DIFF87L_ Send04 _GrO_	Free configurable signal to be sent via communication channel
DIFF87L_ Send05 _GrO_	Free configurable signal to be sent via communication channel
DIFF87L_ Send06 _GrO_	Free configurable signal to be sent via communication channel
DIFF87L_ Send07 _GrO_	Free configurable signal to be sent via communication channel
DIFF87L_ Send08 _GrO_	Free configurable signal to be sent via communication channel
DIFF87L_ Send09 _GrO_	Free configurable signal to be sent via communication channel
DIFF87L_ Send10 _GrO_	Free configurable signal to be sent via communication channel
DIFF87L_ Send11 _GrO_	Free configurable signal to be sent via communication channel
DIFF87L_ Send12 _GrO_	Free configurable signal to be sent via communication channel

This list is the same for all variants of the function.

DIFF87L_Rec207_Grl_	Receive2 Ch7	Free configurable signal received via communication channel 2
DIFF87L_Rec208_Grl_	Receive2 Ch8	Free configurable signal received via communication channel 2
DIFF87L_Rec209_Grl_	Receive2 Ch9	Free configurable signal received via communication channel 2
DIFF87L_Rec210_Grl_	Receive2 Ch10	Free configurable signal received via communication channel 2
DIFF87L_Rec211_Grl_	Receive2 Ch11	Free configurable signal received via communication channel 2
DIFF87L_Rec212_Grl_	Receive2 Ch12	Free configurable signal received via communication channel 2
DIFF87L_CommFail2_Grl_	CommFail2	Signal indicating communication failure in channel 2

4.1.27.2.2.5. On-line data

Visible values on the on-line data page:

Table 2-6 The online displayed values of the line differential protection function

SIGNAL TITLE	DIMENSION	EXPLANATION
I Diff L1	p.u. *In	Differential current in line L1
I Diff L2	p.u. *In	Differential current in line L2
I Diff L3	p.u. *In	Differential current in line L3
I Bias	p.u. *In	Restraint current
Trip L1	-	Trip command in line L1
Trip L2	-	Trip command in line L2
Trip L3	-	Trip command in line L3
Trip	-	General trip command
Receive Ch1	-	Signal Ch1 received via communication channel
Receive Ch2	-	Signal Ch2 received via communication channel
Receive Ch3	-	Signal Ch3 received via communication channel
Receive Ch4	-	Signal Ch4 received via communication channel
Receive Ch5	-	Signal Ch5 received via communication channel
Receive Ch6	-	Signal Ch6 received via communication channel
Receive Ch7	-	Signal Ch7 received via communication channel
Receive Ch8	-	Signal Ch8 received via communication channel
Receive Ch9	-	Signal Ch9 received via communication channel
Receive Ch10	-	Signal Ch10 received via communication channel
Receive Ch11	-	Signal Ch11 received via communication channel
Receive Ch12	-	Signal Ch12 received via communication channel
CommFail	-	Communication failure

Table 2-7 The online displayed values of the optional two-channel variant

SIGNAL TITLE	DIMENSION	EXPLANATION
I Diff L1	p.u. *In	Differential current in line L1
I Diff L2	p.u. *In	Differential current in line L2
I Diff L3	p.u. *In	Differential current in line L3
I Bias	p.u. *In	Restraint current
Trip L1	-	Trip command in line L1
Trip L2	-	Trip command in line L2
Trip L3	-	Trip command in line L3
Trip	-	General trip command
Receive1 Ch1	-	Signal Ch1 received via communication channel 1
Receive1 Ch2	-	Signal Ch2 received via communication channel 1
Receive1 Ch3	-	Signal Ch3 received via communication channel 1
Receive1 Ch4	-	Signal Ch4 received via communication channel 1
Receive1 Ch5	-	Signal Ch5 received via communication channel 1
Receive1 Ch6	-	Signal Ch6 received via communication channel 1
Receive1 Ch7	-	Signal Ch7 received via communication channel 1
Receive1 Ch8	-	Signal Ch8 received via communication channel 1
Receive1 Ch9	-	Signal Ch9 received via communication channel 1
Receive1 Ch10	-	Signal Ch10 received via communication channel 1
Receive1 Ch11	-	Signal Ch11 received via communication channel 1

Receive1 Ch12	-	Signal Ch12 received via communication channel 1
Receive2 Ch1	-	Signal Ch1 received via communication channel 2
Receive2 Ch2	-	Signal Ch2 received via communication channel 2
Receive2 Ch3	-	Signal Ch3 received via communication channel 2
Receive2 Ch4	-	Signal Ch4 received via communication channel 2
Receive2 Ch5	-	Signal Ch5 received via communication channel 2
Receive2 Ch6	-	Signal Ch6 received via communication channel 2
Receive2 Ch7	-	Signal Ch7 received via communication channel 2
Receive2 Ch8	-	Signal Ch8 received via communication channel 2
Receive2 Ch9	-	Signal Ch9 received via communication channel 2
Receive2 Ch10	-	Signal Ch10 received via communication channel 2
Receive2 Ch11	-	Signal Ch11 received via communication channel 2
Receive2 Ch12	-	Signal Ch12 received via communication channel 2
CommFail1	-	Communication failure in communication channel 1
CommFail2	-	Communication failure in communication channel 2

4.1.27.2.2.6. Events

The following events are generated in the event list, as well as sent to SCADA according to the configuration.

Table 2-8 Events of the line differential protection function

EVENT	VALUE	EXPLANATION
Trip L1	off, on	Trip command in line L1
Trip L2	off, on	Trip command in line L2
Trip L3	off, on	Trip command in line L3
Trip	off, on	General trip command
CommFail	off, on	Communication failure

Table 2-9 Events of the optional two-channel variant

EVENT	VALUE	EXPLANATION
Trip L1	off, on	Trip command in line L1
Trip L2	off, on	Trip command in line L2
Trip L3	off, on	Trip command in line L3
Trip	off, on	General trip command
CommFail1	off, on	Communication failure in communication channel 1
CommFail2	off, on	Communication failure in communication channel 2

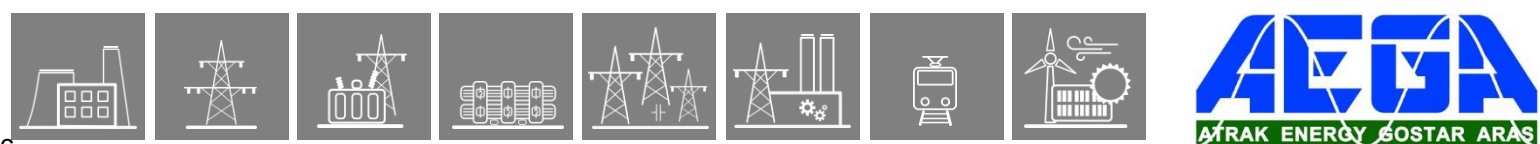

4.1.27.2.3. Technical data

Table 2-10 Technical data of the transformer differential protection

FUNCTION	VALUE	ACCURACY
Operating characteristic	2 breakpoints and unrestrained decision	
Reset ratio	0.95	
Characteristic accuracy ($I_{bias} > 2 \times I_n$)		<2%
Operate time ($I_{bias} > 0.3 \times I_n$)	Typically 35 ms	
Reset time	Typically 60 ms	

*Bias current is above $0.2 I_n$

4.1.27.2.3.1. Notes for testing

There is an XRIO setting file available for the function block which can be downloaded from the Protecta website. With the XRIO file, only the parameters of the CT modules and the differential protection function should be entered along the type of the fault to be generated. By using this file, testing the operation characteristic will not need any further setting.

Normally in the EuroProt+ devices the trip contacts are assigned to the Trip Logic function block, and not to the protection function blocks. Because of this the testing personnel must make sure that the Trip Logic is switched on ('Operation' parameter is set to other than 'Off') before starting the testing, otherwise there will be no physical trip on the relay.

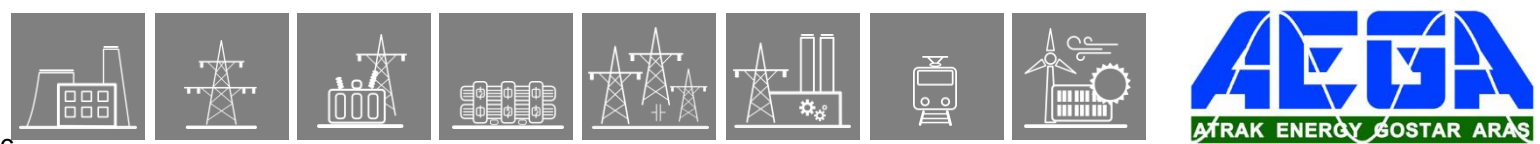

4.1.28. Weak end infeed logic

4.1.28.1. Application

The communication schemes for the distance protection applicable for the Protecta EuroProt+ device are described in the document “EuroProt+ Teleprotection function block description”. The aim of these schemes is to accelerate the trip time in case of faults at the far line ends, which cannot be covered with the fast Zone1.

The permissive communication schemes

- Permissive underreach transfer trip (PUTT). The IEC standard name of this mode of operation is Permissive Underreach Protection (PUP);
- Permissive overreach transfer trip (POTT). The IEC standard name of this mode of operation is Permissive Overreach Protection (POP);
- Directional comparison;
- Direct underreaching transfer trip (DUTT). The IEC standard name of this mode of operation is Intertripping Underreach Protection (IUP)

need permissive signal from the remote end protection device. If this signal is not received then the trip signal can be generated with the selective time delay only.

The protection at the far end of the line cannot detect the fault if

- The circuit breaker is open in all three phases, or
- The fault current, due to the weak source at the far end, is not enough to detect the fault.

In these cases the “weak end infeed logic” function block can generate the required permissive signal of the far end protection.

4.1.28.2. Mode of operation

The “weak end infeed logic” can be blocked

- by parameter setting (Operation=Off) (Op_Epar=0)
- by blocking input signal (Blk), programmed by the user, using the graphic logic.

If the operation of the function is not blocked then the function can generate binary output signals:

- “WEI trip”: this signal is intended to input in the trip logic to generate a trip signal to the own circuit breaker
- “Send signal”: this signal is the permissive signal, intended to be sent to the protection at the far line end.
- “Send echo”: this signal is the echoed signal received from the far line end device, and to be sent back to the far line end device.

The signal selection is performed using the parameter “Operation”:

- If the setting is “Operation=Echo only” then no signal is generated to the own circuit breaker.
- If the setting is “Operation=Echo and Trip” then both Echo and Trip signals can be generated.

4.1.28.3. Structure of the weak end infeed logic

Fig.1-2 shows the structure of the weak end infeed logic.

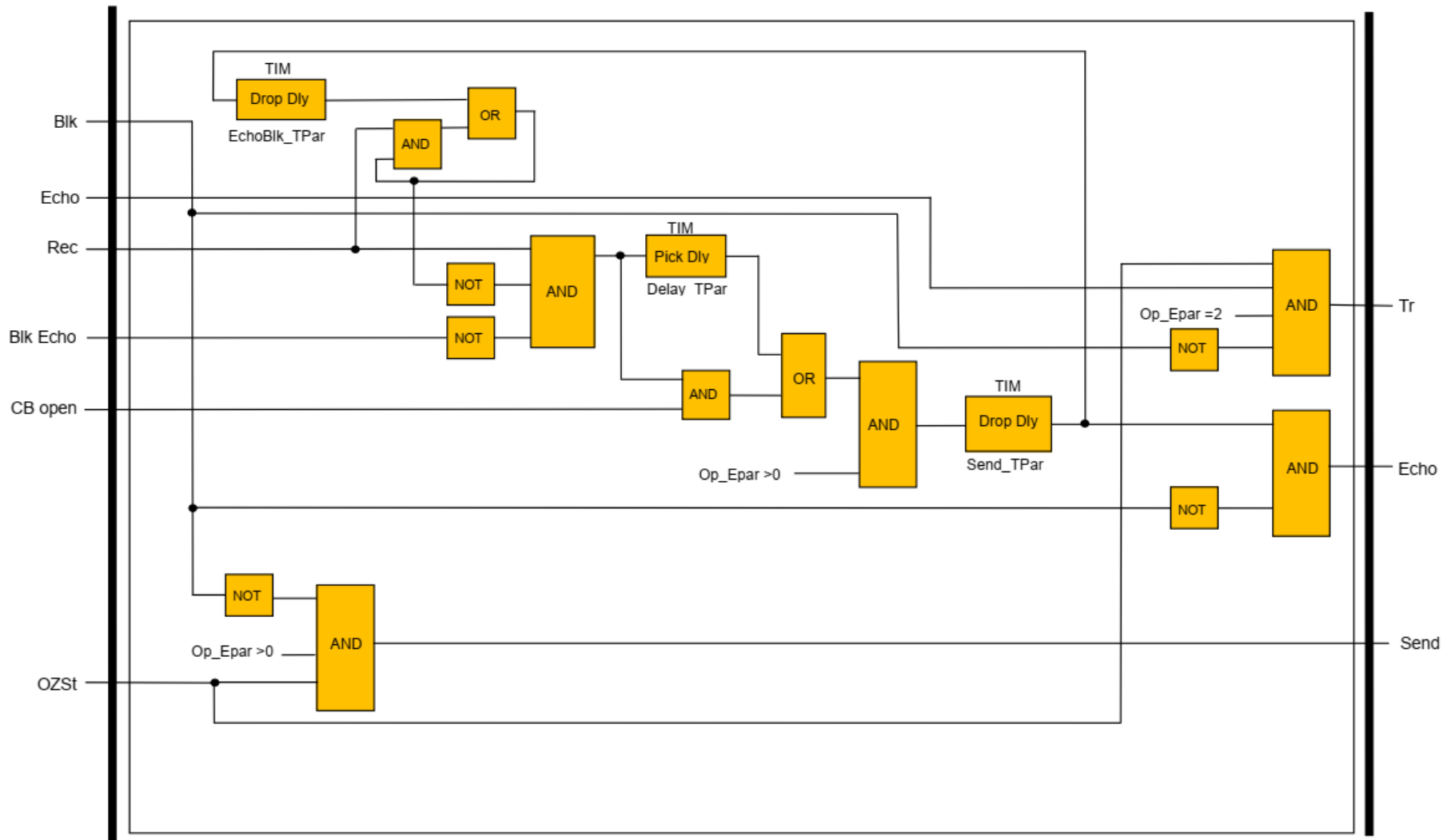
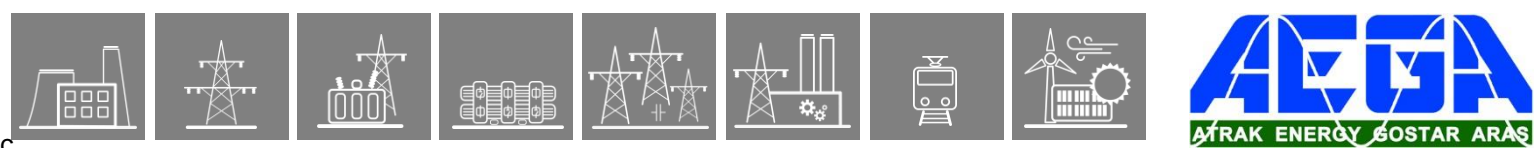

Figure 1-1 Structure of the weak end infeed logic



The short explanation of the logic is as follows:

The function generates a “Send” signal, if forward fault is detected (OZst: the overreach zone started) and the function is enabled (Op_Epar >0) and the function is not blocked (Blk). In this case no “weak end” condition is valid.

Weak end means that either the circuit breaker is open or no forward fault detection is possible due to high source impedance.

If the circuit breaker is open (Input “CB open” signal is active) and permissive signal is received (input “Rec”) then this signal is echoed back to the far end (output signal “Echo”) The drop-delay timer with parameter “Send_Tpar” sets the minimal duration of the Echo signal.

If the circuit breaker is not open then the pick delay timer leaves time for the “Blk Echo” signal (e.g. in case of detection reverse fault) to block echoing. If this signal is not received during the running time then the function generates the “Echo” signal.

The drop delay timer with parameter “EchoBlk_Tpar” prevents repeated signal generation.

The function generates also “Trip signal” if forward fault is detected and received “Echo” signal accelerates trip signal generation. The additional condition is that the parameter setting for “Op_Epar” enables Trip command and the function is not blocked.

4.1.28.4. Technical summary

4.1.28.4.1. Technical data

Function	Value	Accuracy
Timer accuracy	Parameter values	±5% or ±15 ms, whichever is greater

Table 1-1 Technical data of the directional weak end infeed logic

4.1.28.4.2. Summary of the parameters

Enumerated parameters

Parameter name	Title	Selection range	Default
Disabling or operating mode of the function			
WEI_Op_EPar_	Operation	Off, Echo Only, Echo and Trip	Off

Table 1-2 The enumerated parameters of the directional weak end infeed logic

Timer parameters

Parameter name	Title	Unit	Min	Max	Step	Default
WEI_Send_TPar_	Echo Pulse duration	msec	1	100	1	10
WEI_Delay_TPar_	Echo Delay	msec	1	100	1	10
WEI_EchoBlk_TPar_	Echo Block Time	msec	1	100	1	10

Table 1-3 The timer parameters of the directional weak end infeed logic

4.1.28.4.3. Summary of the generated output signals

Binary status signal	Title	Explanation
WEI_Tr_Grl_	WEI Trip	Trip signal of the function
WEI_Send_Grl_	Send Signal	Signal to be sent if start signal of the overreaching zone is available
WEI_Echo_Grl_	Send Echo	Echo signal to be sent

Table 1-4 The binary output status signals of the directional weak end infeed logic

4.1.28.4.4. Summary of the input signals

Binary status signals

The directional residual overcurrent protection function has a binary input status signal. **The conditions are defined by the user applying the graphic equation editor.**

Binary status signal	Title	Explanation
WEI_Blk_GrO	Block	Signal for blocking the function
WEI_Rec_GrO	Receive Signal	Received carrier signal
WEI_Echo_GrO	Receive Echo	Received echo signal
WEI_BlkEcho_GrO	Block Echo	Blocking echo signal sending
WEI_OZSt_GrO	Z Overreach Start	Start signal of the overreach impedance zone
WEI_CBopen_GrO	CB Open 3pole	Status of the circuit breaker indicating three-phase open state

Table 1-5 The binary input signal of the directional weak end infeed logic

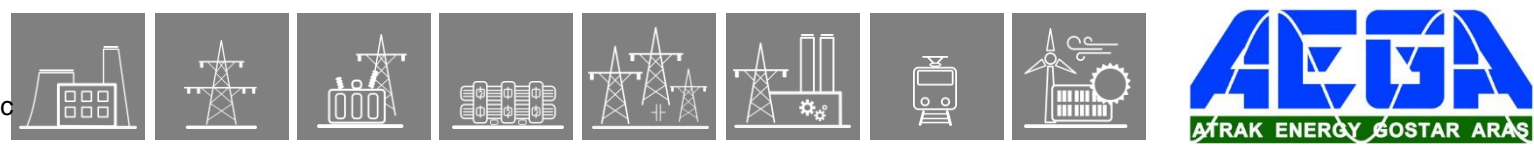

4.1.28.4.5. The function block

The function block of the weak end infeed logic is shown in Figure 1-2. This block shows all binary input and output status signals that are applicable in the graphic logic editor.

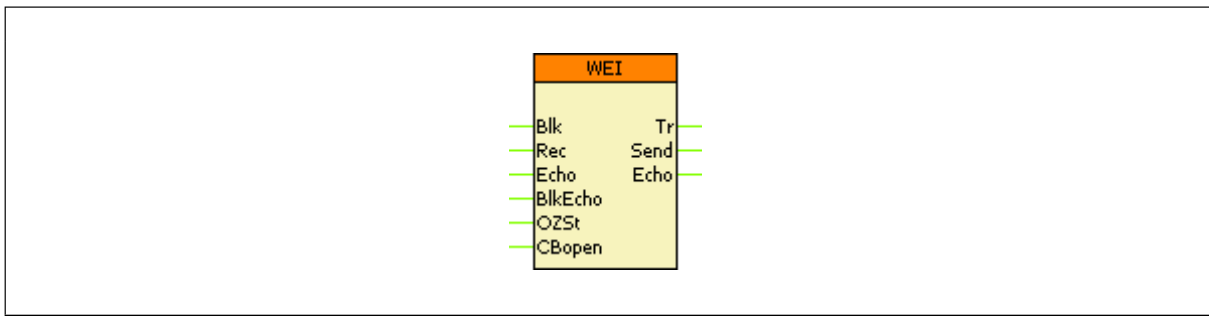

Figure 1-2 The function block of the directional weak end infeed logic

The names of the input and output signals are parts of the “Binary status signal” names listed in Table 1-4 and Table 1-5 above.

4.1.29. Out of Step (Pole slipping) protection function

The pole slipping protection function can be applied mainly for synchronous generators. If a generator falls out of synchronism, then the voltage vector induced by the generator rotates slower or with a higher speed as compared to voltage vectors of the network. The result is that according to the frequency difference of the two vector systems, the cyclical voltage difference on the current carrying elements of the network are overloaded cyclically. To protect the stator coils from the harmful effects of the high currents and to protect the network elements, a disconnection is required.

The pole slipping protection function is designed for this purpose.

Main features

The main features of the pole slipping protection function are as follows:

- A full-scheme system provides continuous measurement of impedances separately in three independent phase-to-phase measuring loops.
- Impedance calculation is conditional on the values of the positive sequence currents being above a defined value.
- A further condition of the operation is that the negative sequence current component is less than 1/6 of the value defined for the positive sequence component.
- The operate decision is based on quadrilateral characteristics on the impedance plane using four setting parameters.
- The number of vector revolutions can be set by a parameter.
- The duration of the trip signal is set by a parameter.
- Blocking/enabling binary input signal can influence the operation.

Technical data

Function	Range	Accuracy
Rated current I_n	1/5A, parameter setting	
Rated Voltage U_n	100/200V, parameter setting	
Current effective range	20 – 2000% of I_n	$\pm 1\%$ of I_n
Voltage effective range	2-110 % of U_n	$\pm 1\%$ of U_n
Impedance effective range $I_n=1A$ $I_n=5A$	0.1 – 200 Ohm 0.1 – 40 Ohm	$\pm 5\%$
Zone static accuracy	48 Hz – 52 Hz 49.5 Hz – 50.5 Hz	$\pm 5\%$ $\pm 2\%$
Operate time	Typically 25 ms	± 3 ms
Minimum operate time	<20 ms	
Reset time	16 – 25 ms	

Table 1 The technical data of the pole slip function

Parameters

Enumerated parameter

Parameter name	Title	Selection range	Default
Parameter for disabling the function			
PSLIP78_Oper_EPar_	Operation	Off, On	Off

Table 2 The enumerated parameter of the pole slip function

Integer parameters

Parameter name	Title	Unit	Min	Max	Step	Default
Definition of the number of the vector revolution up to the trip command:						
PSLIP78_MaxCyc_IPar_	Max. cycle number	cycle	1	10	1	1
Definition of the minimal current for the impedance vector calculation						
PSLIP78_I1Low_IPar_	I1LowLimit	%	50	200	1	120

Table 3 Integer parameters of the pole slip function

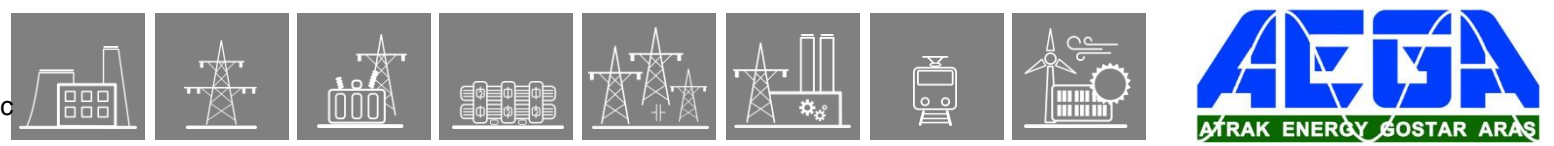

Float parameters

Parameter name	Title	Unit	Min	Max	Digits	Default
R setting of the impedance characteristics in forward direction						
PSLIP78_Rfw_FPar_	R forward	ohm	0.10	150.00	2	10.00
X setting of the impedance characteristics in forward direction						
PSLIP78_Xfw_FPar_	X forward	ohm	0.10	150.00	2	10.00
R setting of the impedance characteristics in backward direction						
PSLIP78_Rbw_FPar_	R backward	ohm	0.10	150.00	2	10.00
X setting of the impedance characteristics in backward direction						
PSLIP78_Xbw_FPar_	X backward	ohm	0.10	150.00	2	10.00

Table 4 The float parameters of the pole slip function

Timer parameters

Parameter name	Title	Unit	Min	Max	Step	Default
Time delay for waiting the subsequent revolution						
PSLIP78_Dead_TPar_	Dead time	msec	1000	60000	1	5000
Generated trip impulse duration						
PSLIP78_TrPu_TPar_	Trip pulse	msec	50	10000	1	150

Table 5 The timer parameters of the pole slip function

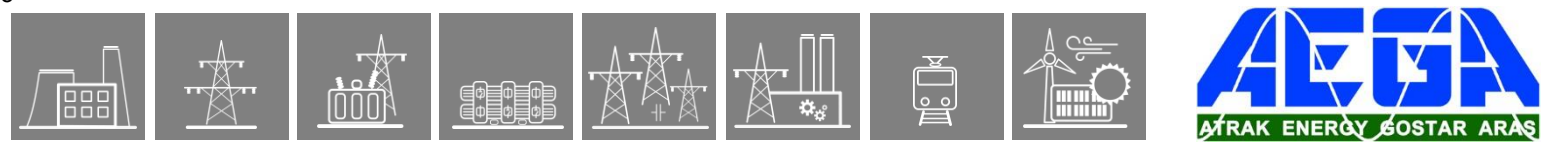

4.1.30. Stub protection function

4.1.30.1. Application

There are short sections of the current path within a substation that are not properly protected by the general protection system. These sections are called stubs and they are usually between the circuit breaker and the current transformer. The general protection system measures the current of the current transformer and if fault is detected, a command is generated to open the circuit breaker.

If, however, the fault is between the circuit breaker and the current transformer, then opening the circuit breaker cannot clear the fault; it is fed via the current transformer from the other side of the protected object. This location is within the back-up zone of the other side protection and, accordingly, it is cleared by a considerable time delay.

The task of the stub protection function is to detect the fault current in the open state of the circuit breaker and to generate a quick trip command to the other side circuit breaker.

Another usual application is in the one-and-a-half circuit breaker arrangement. Here the current transformers are located either before or after the circuit breakers. Additionally, the voltage transformer is either on the bus side or on the line side of the isolator. In the last case the stub is also the section between the circuit breakers and the open line isolator, since if a fault occurs in this section, the detected voltage is independent of the fault; it is unchanged and cannot be applied for the distance protection.

The stub protection function is basically a high-speed overcurrent protection function that is enabled by the open state of a circuit breaker or maybe an isolator.

4.1.30.1.1. Operation of the Stub Protection Algorithm

The stub protection function is basically a high-speed overcurrent protection function that is enabled by the open state of a circuit breaker or maybe an isolator.

The inputs of the stub protection function are

- the Fourier components of three phase currents,
- binary inputs for enabling and activating the operation,
- parameters.

The output of the stub protection function is

- a binary output trip command to be directed to the appropriate circuit breaker(s).

If any of the phase currents is above the start current and the binary status signal activates the operation, then after a user-defined time delay the function generates a trip command.

The function can be disabled by programming the blocking signal.

4.1.30.2. Stub Protection Function Overview

The graphic appearance of the stub protection function block is shown in Figure 2-1. This block shows all binary input and output status signals that are applicable in the graphic equation editor.

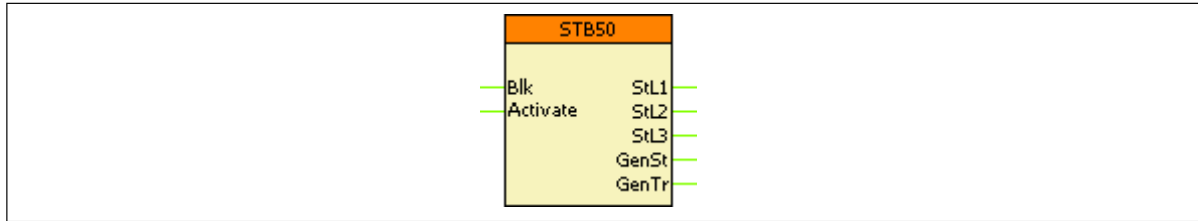

Figure 2-1 The function block of the stub protection function

4.1.30.2.1. Settings

4.1.30.2.1.1. Parameters

The available parameters are listed below in order of their appearance in the *parameters* menu. If the setting range of a parameter should be extended, contact Protecta Support.

Table 2-1 Parameters of the stub protection function

TITLE	DIM	RANGE	STEP	DEFAULT	EXPLANATION
Operation	-	Off, On	-	Off	Parameter for disabling or enabling the function.
Start Current	%	10 – 400	1	50	The function operates if the current goes above this value.
Time Delay	msec	0 – 60000	1	100	Definite time delay from the time of the fault start to the function trip.

4.1.30.2.2. Function I/O

This section briefly describes the analogue and digital inputs and outputs of the function block.

4.1.30.2.2.1. Analogue Inputs

The function uses the sampled values of the three-phase currents.

4.1.30.2.2.2. Binary Input Signals (Graphed Output Statuses)

The conditions of the binary inputs are defined by the user, applying the graphic equation editor (*Logic Editor*). Parts written in **bold** are seen on the left side of the function block in the Logic editor.

Table 2-2 The binary input signals of the stub protection function

BINARY INPUT SIGNAL	SIGNAL TITLE	EXPLANATION
STB50_ Blk _GrO_	Block	Input for disabling the function
STB50_ Activate _GrO_	Activate	TRUE state of this signal indicates activates the function. Usually the open state of the circuit breaker or isolator must be connected to it.

4.1.30.2.2.3. Binary Output Signals (Graphed Input Statuses)

These signals can be used in EuroCAP to assign to LED, user LCD object etc. Parts written in **bold** are seen on the right side of the function block in the *Logic Editor*.

Table 2-3 The binary output signals of the stub protection function

BINARY OUTPUT SIGNAL	SIGNAL TITLE	EXPLANATION
STB50_ StL1 _Grl_	Start L1	Indication of starting of the function in phase L1
STB50_ StL2 _Grl_	Start L2	Indication of starting of the function in phase L2
STB50_ StL3 _Grl_	Start L3	Indication of starting of the function in phase L3
STB50_ GenSt _Grl_	General Start	Starting of the function in any of the three phases
STB50_ GenTr _Grl_	General Trip	Trip command after expiry of the definite time delay

4.1.30.2.2.4. Online Data

The following values are visible in the *online data* page.

Table 2-4 Online data of the stub protection function

SIGNAL TITLE	DIMENSION	EXPLANATION
Start L1	-	Indication of starting of the function in phase L1
Trip L1	-	Indication of tripping of the function in phase L1
Start L2	-	Indication of starting of the function in phase L2
Trip L2	-	Indication of tripping of the function in phase L2
Start L3	-	Indication of starting of the function in phase L3
Trip L3	-	Indication of tripping of the function in phase L3
General Start	-	Starting of the function in any of the three phases
General Trip	-	Trip command after expiry of the definite time delay

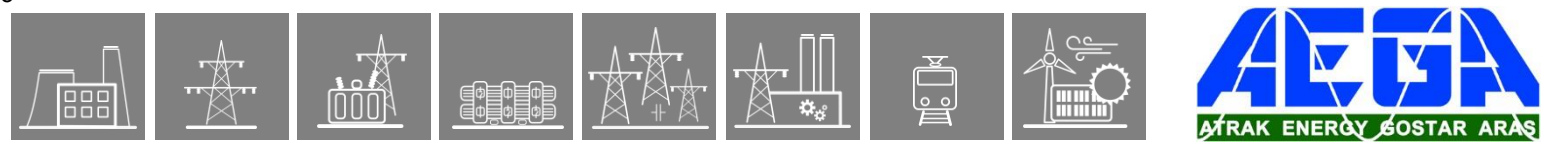

4.1.30.2.2.5. Events

The following events are generated in the event list, as well as sent to the SCADA according to the configuration.

Table 2-5 Generatable events of the stub protection function

EVENT	VALUE	EXPLANATION
Start L1	off, on	Indication of starting of the function in phase L1
Start L2	off, on	Indication of starting of the function in phase L2
Start L3	off, on	Indication of starting of the function in phase L3
General Start	off, on	Starting of the function in any of the three phases
General Trip	off, on	Trip command after expiry of the definite time delay



4.1.30.2.3. Technical Data

Table 2-6 Technical data of the stub protection function

FUNCTION	VALUE	ACCURACY
Current accuracy	20 – 2000% of I_n	$\pm 1\%$ of I_n

4.1.30.2.3.1. Notes for Testing

Normally in the EuroProt+ devices the trip contacts are assigned to the Trip Logic function block, and not to the protection function blocks. Because of this, the testing personnel must make sure that the Trip Logic is switched on ('Operation' parameter is set to other than 'Off') before starting the testing, otherwise there will be no physical trip on the relay.

Note that the Activate input of the function must be active to make the function work. If there is no trip, the logic of this input must be checked.

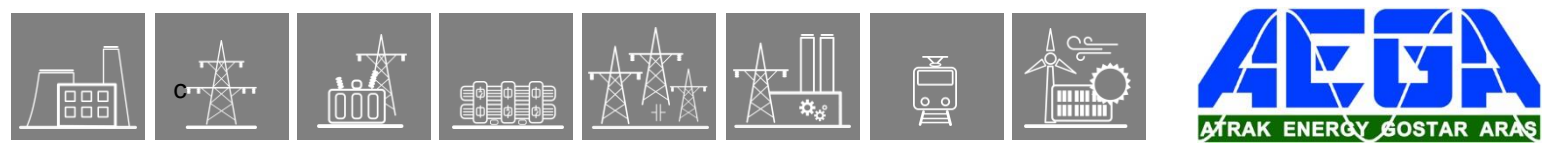

$I_{comp\ x}$ is the compensated current in phase x
 I_x is the measured current in phase x
 $I_{C\ x}$ is the charging current in phase x

The line differential protection function gets the compensated current.

The current compensation can be enabled with binary parameter setting, and also the binary input can block the algorithm. In disabled or blocked state the charging current is considered to be zero, the line differential protection function uses the measured line currents.

4.1.31.3. Structure of the charging current compensation

Figure 1-1 shows the structure of the algorithm.

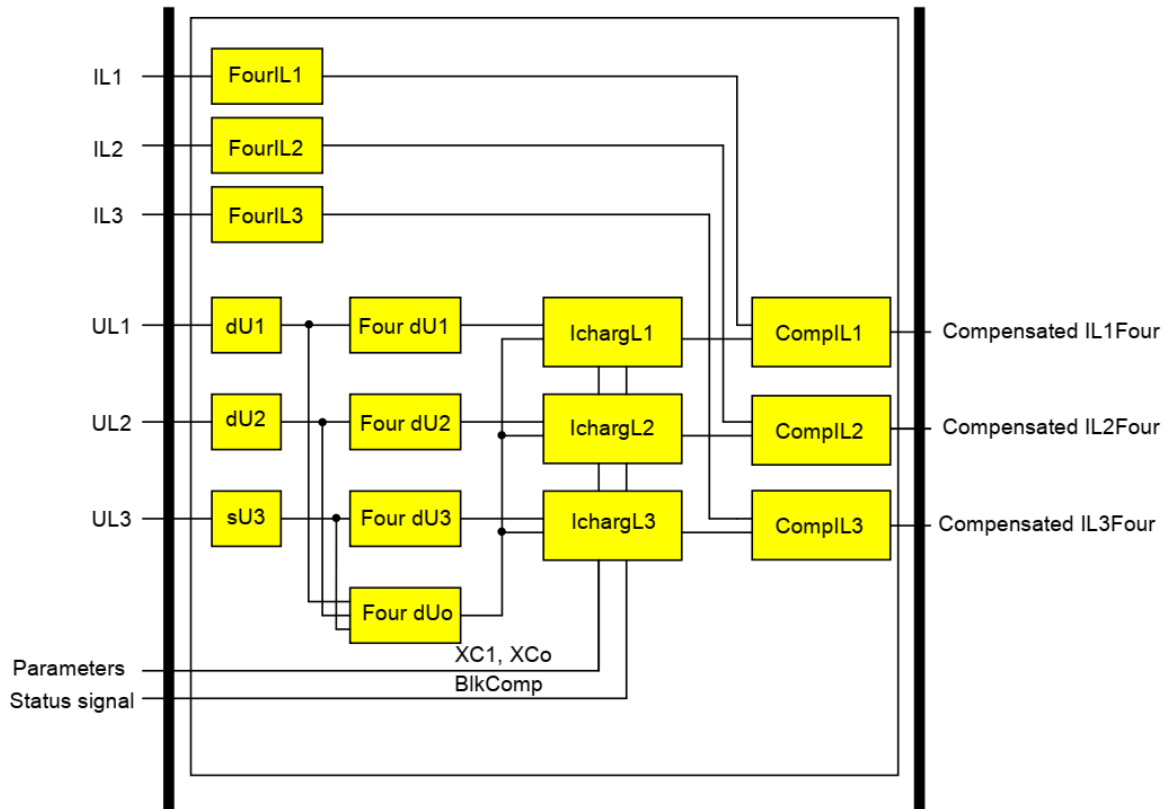
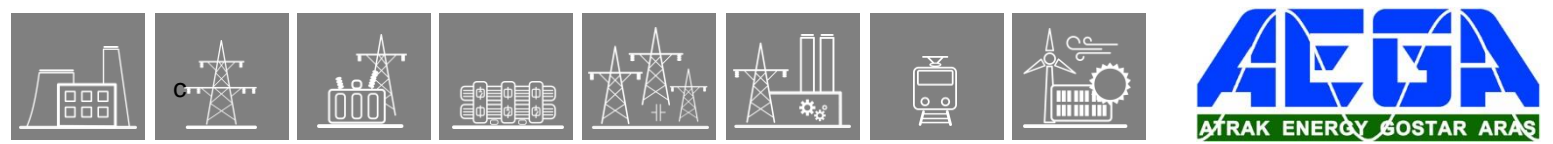

Figure 1-1 The charging current compensation algorithm



The **inputs** are

- sampled values of the three line currents (IL1, IL2, IL3),
- sampled values of the three phase voltages (UL1, UL2, UL3),
- parameters,
- status signal.

The **outputs** are

- the Fourier components of the compensated line currents.

The **software modules** of the charging current compensation function:

Fourier IL1, IL2, IL3

These modules calculate the Fourier components of the measured line currents. In disabled or blocked state the charging current is considered to be zero, the line differential protection function uses these currents.

dU1, dU2, dU3

These modules calculate the derivatives of the measured phase voltages.

Fourier dU1, dU2, dU3

These modules calculate the Fourier components of the derivatives of the measured phase voltages.

Fourier dUo

This module calculates the Fourier components of the derivatives of the zero sequence voltage component.

lcharg L1, L2, L3

These modules calculate the Fourier components of the charging currents. The method of calculation is described in Chapter 1.1.

Comp IL1, IL2, IL3

These modules calculate the Fourier components of the compensated currents by subtracting the charging current from the measured line currents. In disabled or blocked state the charging current is considered to be zero, the line differential protection function uses the measured line currents.

The line differential protection gets the compensated currents.

4.1.31.4. Technical summary

4.1.31.4.1. Summary of the parameters

Enumerated parameter

Parameter name	Title	Selection range	Default
Enabling charging current compensation			
CCC_Comp_EPar_	Compensation	Off, On	Off

Table 1-1 The enumerated parameter of the charging current compensation function

Float parameters

Parameter name	Title	Unit	Min	Max	Step	Default
Positive sequence capacitive reactance of the line or cable						
CCC_XC1_FPar_	XC1	ohm	100	2000	0.1	500
Zero sequence capacitive reactance of the line or cable						
CCC_XC0_FPar_	XC0	ohm	100	2000	0.1	500

Table 1-2 Float parameters of the charging current compensation function

4.1.31.4.2. Summary of the generated output signals

The charging current compensation function block does not generate any binary output signal.

4.1.31.4.3. Summary of the input signals

Binary status signal

The charging current compensation function has a binary input status signal. **The conditions are defined by the user applying the graphic equation editor.**

Binary status signal	Title	Explanation
CCC_BlkcComp_GrO_	BlkcComp	Disabling charging current compensation

Table 1-3 The binary input signal of the charging current compensation function

4.1.31.4.4. The function block

The function block of the charging current compensation function is shown in Figure 1-2. This block shows all binary input and output status signals that are applicable in the graphic equation editor.

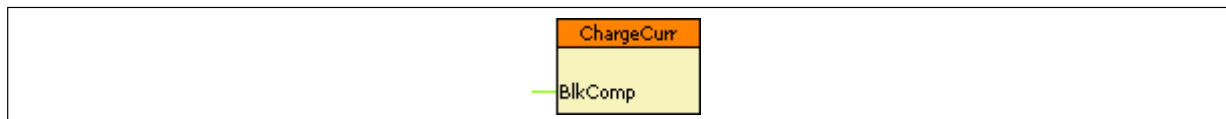

Figure 1-2 The function block of the charging current compensation function

The name of the signal is part of the “Binary status signal” name, shown in Table 1-3 above.

4.2. Control & supervision functions

4.2.1. Phase-Selective Trip Logic

4.2.1.1. Operation principle

The phase-selective trip logic function operates according to the functionality required by the IEC 61850 standard for the "Trip logic logical node".

4.2.1.1.1. Application

The phase-selective function is applied when one-phase trip commands might be required, mostly in distance protection applications.

The function receives the trip requirements of the protective functions implemented in the device and combines the binary signals and parameters to the outputs of the device.

The trip requirements are programmed by the user, using the graphic equation editor. The decision logic has the following aims:

- Define a minimal impulse duration even if the protection functions detect a very short time fault,
- In case of phase-to-phase faults, involve the third phase in the trip command,
- Fulfill the requirements of the automatic reclosing function to generate a three-phase trip command even in case of single-phase faults,
- In case of an evolving fault, during the evolving fault waiting time include all three phases into the trip command

4.2.1.1.2. The decision logic

The decision logic module combines the status signals and the enumerated parameter to generate the general trip command on the output module of the device.

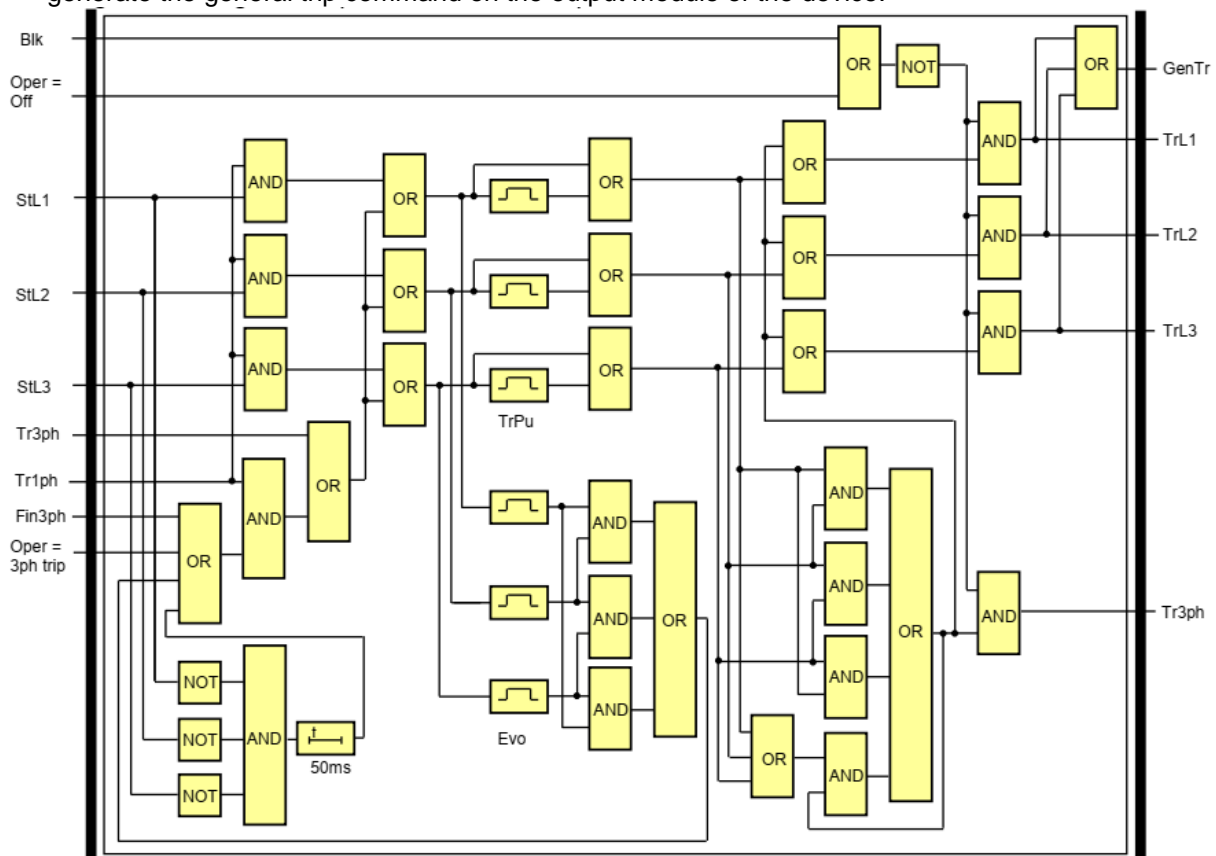

Figure 1-1 Logic scheme of the decision logic

4.2.1.2.2.4. Binary output signals (graphed input statuses)

The binary output status signals of the differential protection function. Parts written in **bold** are seen on the function block in the logic editor.

BINARY OUTPUT SIGNAL	SIGNAL TITLE	EXPLANATION
TRC94_TrL1_Grl_	Trip L1	Generated trip command for phase L1
TRC94_TrL2_Grl_	Trip L2	Generated trip command for phase L2
TRC94_TrL3_Grl_	Trip L3	Generated trip command for phase L3
TRC94_GenTr_Grl_	General Trip	Generated general trip command (active for 1ph and 3ph trips as well)
TRC94_Tr3ph_Grl_	3Ph Trip	Generated three-phase trip command

Table 2-3 The binary output signal of the phase-selective trip logic function

4.2.1.2.2.5. On-line data

Visible values on the on-line data page:

SIGNAL TITLE	DIMENSION	EXPLANATION
General Trip	-	Status of the General Trip binary output
Trip L1	-	Status of the Trip L1 binary output
Trip L2	-	Status of the Trip L2 binary output
Trip L3	-	Status of the Trip L3 binary output
3Ph Trip	-	Status of the 3Ph Trip binary output

Table 2-4 On-line data of the phase-selective trip logic function

4.2.1.2.2.6. Events

The following events are generated in the event list, as well as sent to SCADA according to the configuration.

EVENT	VALUE	EXPLANATION
Trip L1	off, on	Status of the Trip L1 binary output
Trip L2	off, on	Status of the Trip L2 binary output
Trip L3	off, on	Status of the Trip L3 binary output
General Trip	off, on	Status of the General Trip binary output

Table 2-5 Event of the phase-selective trip logic function

4.2.1.2.3. Technical data

FUNCTION	VALUE	ACCURACY
Pulse time		< 3 ms

Table 2-6 The technical data of the phase-selective trip logic function

4.2.1.2.3.1. Notes for testing

When using an EuroProt+ device with phase-selective trip logic, the first 3 trip contacts of the trip module are assigned to the corresponding Trip L1-L2-L3 outputs of the Trip Logic function block. These assignments can be checked in the configuration file of the device by using the EuroCAP tool (see the picture below, note that the actual configuration might be different from that of on the figure). It is possible to assign multiple contacts to one trip logic output (mainly when two trip circuits are used).

▼ E1-Line_F

- ▼ Hardware Configuration
 - Connector allocation
 - LED assignment
 - ▼ IO Signals
 - > Analogue Inputs
 - > Analogue Outputs
 - > Binary Inputs
 - > Binary Outputs
 - ▼ Trip definition
 - Assignment
 - Communication
 - > Software Configuration
 - Subscribed GOOSE assignment
 - > System

Trip definition / Assignment

Add

Insert

Remove

Modify

Move Up

Move Dn

Ix	Name	Title	Defined by	Show order	Parameters	Type
0	TripAssign1	Trip L1	RootFunctionBlock		TRC94_TripL1_TLO_TripContact_O02	4444 Trip assign
1	TripAssign2	Trip L2	RootFunctionBlock		TRC94_TripL2_TLO_TripContact_O04	4444 Trip assign
2	TripAssign3	Trip L3	RootFunctionBlock		TRC94_TripL3_TLO_TripContact_O06	4444 Trip assign

Figure 2-2 Trip assignment in EuroCAP

During commissioning the testing personnel must make sure that, along with the protection functions under test, the corresponding Trip Logic(s) is (are) switched on ('Operation' parameter is set to other than 'Off') before starting the testing, otherwise there will be no actual trip signal given on the assigned trip contacts.

4.2.2. Circuit breaker wear monitoring function

If a circuit breaker interrupts a current, the electric arc between the contacts results some metal loss. If the metal loss due to the burning of the electric arc becomes substantial, the contacts must be replaced.

Manufacturers define the permitted number of short circuits by formulas such as:

$$\sum_{i=1}^n I_i^k = CycNum$$

where

n = number of short circuits

k = exponent, calculated by the algorithm, based on the parameters I = short-circuit current, kA (RMS)

CycNum = total value of weighted breaking currents.

Similar information is conveyed by the diagram below. This shows the number of permitted interruptions (logarithmic scaling) versus short-circuit current (logarithmic scaling) that the contacts in a circuit breaker can manage before the metal loss due to burning becomes so significant that the contacts must be replaced.

Number of interruptions

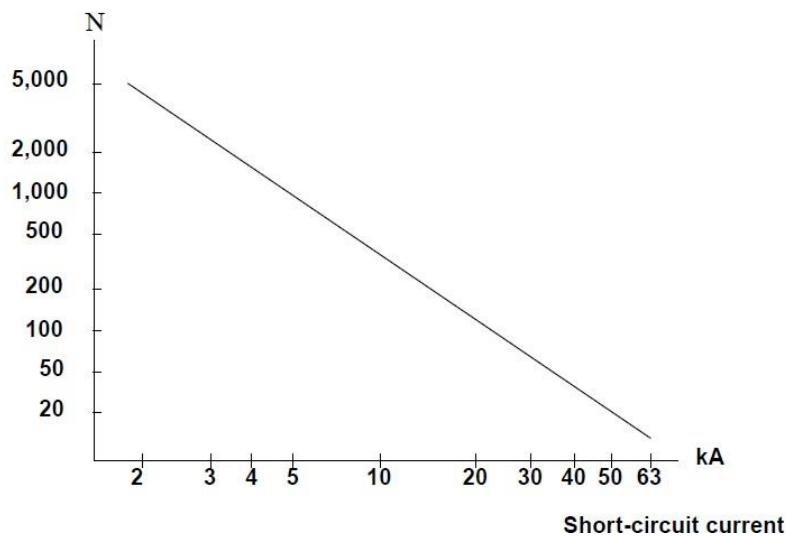

Figure 1-1 Example: Number of permitted interruptions as the function of the interrupted current

The straight line of the curve is defined by two points:

- The number of permitted interruptions of 1 kA current (CycNum - 1kA)
- The number of permitted interruptions of the rated breaking current of the circuit breaker (CycNum – I Rated Trip).

The circuit breaker wear monitoring function finds the maximum value of the phase currents of each interruption and calculates the wear caused by the operation performed. If the sum of the calculated wear reaches the limit, a warning signal is generated. This indicates the time of the required preventive maintenance of the circuit breaker.



4.2.2.1. Operation of the circuit breaker wear monitoring algorithm

The operating principle of the circuit breaker wear monitoring function is based on curves similar to the one shown in [Figure 1-1](#). With this figure, the manufacturer of the circuit breaker defines the permitted total number of current interruptions up to the subsequent preventive maintenance.

The straight line of the curve is defined by two points:

- The number of interruptions of 1 kA current, by parameter `CBWear_CycNumIn_IPar_` (`CycNum - 1kA`)
- The number of interruptions of the rated breaking current of the circuit breaker by parameter `CBWear_CycNumInTrip_IPar_` (`CycNum - I Rated Trip`). The rated breaking current of the circuit breaker is set by parameter `CBWear_InTrCB_FPar_` (`Rated Trip Current`)

The circuit breaker wear monitoring function processes the Fourier basic harmonic component of the three phase currents.

The circuit breaker wear monitoring function identifies the highest value of the phase currents at each interruption.

The procedure of monitoring starts at the receipt of a trip command on the dedicated input (`Trip`). For the start of this procedure, the circuit breaker also needs to be in closed state. This signal is received on the dedicated binary input (`CB Closed`).

The procedure of identifying the maximum phase current value terminates when the current falls below the minimum current defined by the parameter `CBWear_Imin_FPar_` (`Min Current`) AND the circuit breaker gets in open position. This signal is received on the dedicated binary input (`CB Open`).

The procedure also stops if the time elapsed since its start exceeds 1 s. In this case no CB wear is calculated.

Based on the characteristic defined above, the function calculates the wear caused by the operation performed. If the sum of the calculated wear reaches the limit defined by the parameter `CBWear_CycNumAlm_IPar_` (`CycNum - Alarm`), a warning signal is generated (`Alarm`). This indicates the advised time of the preventive maintenance of the circuit breaker.

The accumulated “wear” of the circuit breaker is stored on non-volatile memory; therefore, the value is not lost even if the power supply of the devices is switched off.

This information is displayed among the on-line data as “Actual wear”. This counter indicates how many 1 kA equivalent switches were performed since the last maintenance (reset).

When preventive maintenance is performed, the accumulated “wear” of the circuit breaker must be reset to 0 to start a new maintenance cycle. The circuit breaker wear monitoring function offers two ways of resetting:

- Binary True signal programmed to the “Reset” input of the function
- Performing a direct command via the Commands menu of the supervising WEB browser (for details, see the “Europrot+ manual”, “Remote user interface description” document). The Command window looks like [Figure 1-2](#).



Figure 1-2 The command window to reset the CB wear counter

The **inputs** of the circuit breaker wear monitoring function are

- the Fourier components of three phase currents,
- binary inputs,
- parameters.

The **output** of the circuit breaker wear monitoring function is

- the Alarm binary output status signal.
-

4.2.2.2. Technical summary

4.2.2.2.1. Technical data

Function	Range	Accuracy
Current accuracy	20 – 2000% of I_n	$\pm 1\%$ of I_n
Accuracy in tracking the theoretical wear characteristics		5%

Table 1-1 Technical data of the circuit breaker wear monitoring

4.2.2.2.2. Summary of the parameters

The parameters of the circuit breaker wear monitoring function are explained in the following tables.

Enumerated parameter

Parameter name	Title	Selection range	Default
Disabling or enabling the operation of the function			
CBWear_Oper_EPar_	Operation	Off, On	Off

Table 1-2 The enumerated parameter of the circuit breaker wear monitoring function

Integer parameters

Parameter name	Title	Unit	Min	Max	Step	Default
Permitted number of trip operation if the breaking current is 1kA						
CBWear_CycNumInIPar_	CycNum - 1kA		1	100000	1	50000
Permitted number of trip operation if the breaking current is InTrip (See floating parameter "Rated Trip Current")						
CBWear_CycNumInTrip_IPar_	CycNum – I Rated Trip		1	100000	1	100
Permitted level of the weighted sum of the breaking currents						
CBWear_CycNumAlm_IPar_	CycNum - Alarm		1	100000	1	50000

Table 1-3 The integer parameters of the circuit breaker wear monitoring function

Floating point parameters

Parameter name	Title	Unit	Min	Max	Step	Default
Rated breaking current of the circuit breaker						
CBWear_InTrCB_FPar_	Rated Trip Current	kA	10	100	0.01	10
Minimum level of the current below which the procedure to find the highest breaking current is stopped						
CBWear_lmin_FPar_	Min Current	kA	0.10	0.50	0.01	0.10

Table 1-4 The floating-point parameters of the circuit breaker wear monitoring function

4.2.2.2.3. Binary output status signals

The **binary output status signals** of the circuit breaker wear monitoring function.

Binary output signals	Signal title	Explanation
Alarm signal of the function block		
CBWear_Alarm_GrI_	Alarm	Alarm signal is generated if the weighted sum of the breaking currents is above the permitted level

Table 1-5 The binary output status signal of the circuit breaker wear monitoring function

4.2.2.2.4. The binary input status signals

The **binary inputs** are signals influencing the operation of the circuit breaker wear monitoring function. These signals are the results of logic equations graphically edited by the user.

Binary input signals	Signal title	Explanation
Disabling the function		
CBWear_BlK_GrO_	Blk	The programmed True state of this input disables the operation of the function
Open state of the circuit breaker		
CBWear_Open_GrO_	Open	The open state of the circuit breaker is needed to stop the procedure to find the maximum breaking current
Closed state of the circuit breaker		

CBWear_Closed_GrO_	Closed	The closed state of the circuit breaker is needed to perform the procedure to find the maximum breaking current
Trip command to the circuit breaker		
CBWear_Trip_GrO_	Trip	This signal starts the procedure to find the highest breaking current
Reset command		
CBWear_Reset_GrO_	Reset	If this input is programmed to logic True, at maintenance the weighted sum of the breaking currents can be set to 0

Table 1-6 The binary input signals of the circuit breaker wear monitoring function

4.2.2.2.5. The function block

The function block of the circuit breaker wear monitoring function is shown in [Figure 1-3](#). This block shows all binary input and output status signals that are applicable in the graphic equation editor.

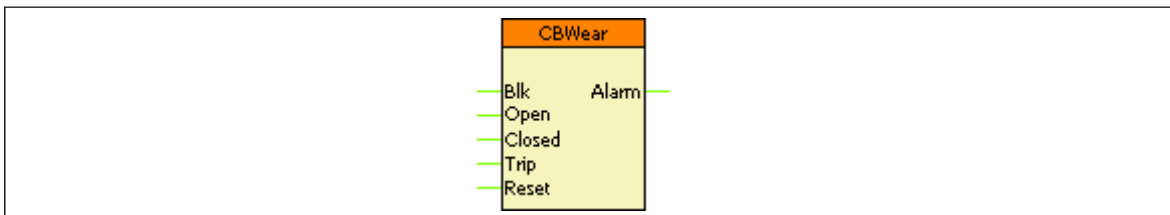
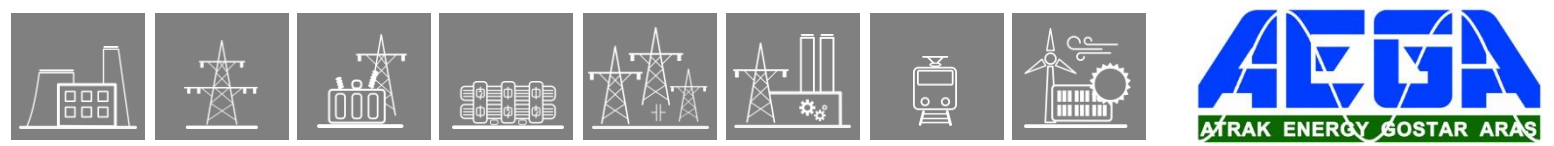

Figure 1-3 The function block of the circuit breaker wear monitoring function



4.2.3. Circuit breaker control function block

4.2.3.1. Application

The circuit breaker control block can be used to integrate the circuit breaker control of the EuroProt+ device into the station control system and to apply active scheme screens of the local LCD of the device.

4.2.3.1.1. Mode of operation

The circuit breaker control block receives remote commands from the SCADA system and local commands from the local LCD of the device, performs the prescribed checking and transmits the commands to the circuit breaker. It processes the status signals received from the circuit breaker and offers them to the status display of the local LCD and to the SCADA system.

Main features:

- Local (LCD of the device) and Remote (SCADA) operation modes can be enabled or disabled individually.
- The signals and commands of the synchro-check / synchro-switch function block can be integrated into the operation of the function block.
- Interlocking functions can be programmed by the user applying the inputs “EnaOff” and “EnaOn”, using the graphic equation editor.
- Programmed conditions can be used to temporarily disable the operation of the function block using the graphic equation editor.
- The function block supports the control models prescribed by the IEC 61850 standard.
- All necessary timing tasks are performed within the function block:
 - Time limitation to execute a command
 - Command pulse duration
 - Filtering the intermediate state of the circuit breaker
 - Checking the synchro-check and synchro-switch times
 - Controlling the individual steps of the manual commands
- Sending trip and close commands to the circuit breaker (to be combined with the trip commands of the protection functions and with the close command of the automatic reclosing function; the protection functions and the automatic reclosing function directly gives commands to the CB). The combination is made graphically using the graphic equation editor
- Operation counter
- Event reporting

4.2.3.2. Circuit Breaker control function overview

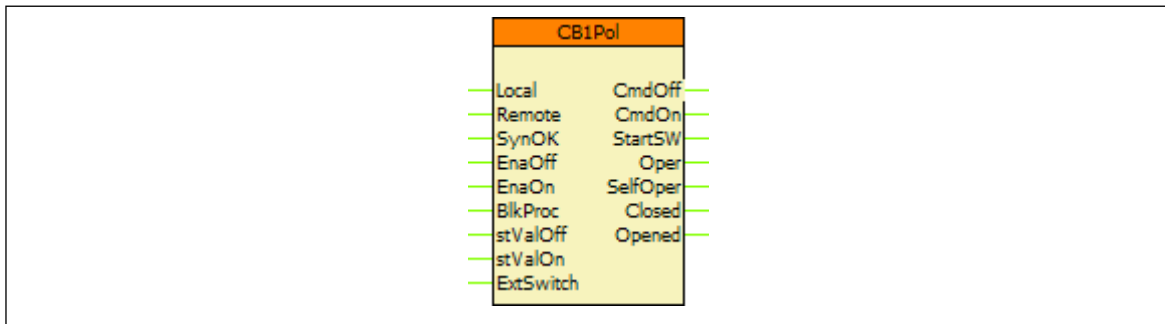

Figure 2-1 Graphic appearance of the function block of the circuit breaker control function

4.2.3.3. Settings

4.2.3.3.1. Parameters

TITLE	DIM	RANGE	STEP	DEFAULT	EXPLANATION
ControlModel	-	Direct normal, Direct enhanced, SBO enhanced	-	Direct normal	The control model of the circuit breaker node according to the IEC 61850 standard
Forced Check	-	FALSE, TRUE	-	TRUE	If true, then the check function cannot be neglected by the check attribute defined by the IEC 61850 standard
Max Operating Time	ms	10 – 1000	1	200	When either enhanced control model is selected, the status of the CB must change within this time after the issued command. At timeout an invalid-position error will be generated for the client.
Pulse Duration	ms	50 – 1000	1	300	Duration of the generated On and Off impulse*
Max Intermediate Time	ms	20 – 500	1	100	Waiting time for status signals, at expiry the CB is reported to be in intermediate state
Max SynCheck Time	ms	10 – 5000	1	1000	Length of the time period to wait for the conditions of the synchronous state. After expiry of this time, the synchro-switch procedure is initiated (see synchro-check/ synchro-switch function block description)
Max SynSW Time**	ms	0 – 60000	1	0	Length of the time period to wait for the synchro-switch impulse (see synchro-check/ synchro-switch function block description). After this time the function resets, no switching is performed
SBO Timeout	ms	1000 – 20000	1	5000	Duration of the waiting time between object selection and command selection. At timeout no command is performed

* If the input status signals (stValOff, stValOn) indicate the successful switching then the pulse is withdrawn, but the minimum duration is 100 ms (factory setting).

** If this parameter is set to 0, then the "StartSW" output is not activated

Table 2-1 Parameters of the circuit breaker control function

4.2.3.3.2. Function I/O

This section describes briefly the analogue and digital inputs and outputs of the function block.

4.2.3.3.2.1. Binary input signals (graphed output statuses)

The conditions of the inputs are defined by the user, applying the graphic equation editor (logic editor). The part written in **bold** is seen on the function block in the logic editor.

BINARY INPUT SIGNAL	EXPLANATION
CB1Pol_ Local _GrO_	If this input is active, the circuit breaker can be controlled using the local LCD of the device.
CB1Pol_ Remote _GrO_	If this input is active, the circuit breaker can be controlled via remote communication channels of the SCADA system or the device web page ('commands' menu)
CB1Pol_ SynOK _GrO_	This input indicates if the synchronous state of the voltage vectors at both sides of the circuit breaker enables the closing command. This signal is usually generated by the synchro check/ synchro switch function. If this function is not available, set the input to logic true.
CB1Pol_ EnaOff _GrO_	The active state of this input enables the opening of the circuit breaker. The state is usually generated by the <i>interlocking conditions defined graphically by the user</i> .
CB1Pol_ EnaOn _GrO_	The active state of this input enables the closing of the circuit breaker. The state is usually generated by the <i>interlocking conditions defined graphically by the user</i> .
CB1Pol_ BlkProc _GrO_	The active state of this input blocks the operation of the circuit breaker. The conditions are defined graphically by the user.
CB1Pol_ stValOff _GrO_	Off (Opened) state of the circuit breaker.
CB1Pol_ stValOn _GrO_	On (Closed) state of the circuit breaker.
CB1Pol_ ExtSwitch _GrO_	This signal is considered only when evaluating unintended operation (see "SelfOper" output in Chapter 2.2.2). It indicates that an external command has been issued to the circuit breaker (e.g. trip request from other protection device or external on/off command is given).

Table 2-2 The binary input signals of the circuit breaker control function

4.2.3.3.2.2. Binary output signals (graphed input statuses)

The binary output status signals of the differential protection function. Parts written in **bold** are seen on the function block in the logic editor.

BINARY OUTPUT SIGNAL	SIGNAL TITLE	EXPLANATION
CB1Pol_ CmdOff _Grl_	Off Command	Off command impulse, the duration of which is defined by the parameter "Pulse duration"
CB1Pol_ CmdOn _Grl_	On Command	On command impulse, the duration of which is defined by the parameter "Pulse duration"
CB1Pol_ StartSW _Grl_	Start Synchro-switch	If the synchro check/synchro switch function is applied and the synchronous state conditions are not valid for the time defined by the parameter "Max.SynChk time", then this output triggers the synchro switch function (see synchro-check/synchro-switch function block description).
CB1Pol_ Oper _Grl_	Operation	An impulse with a duration of 150 ms at any operation of the circuit breaker
CB1Pol_ SelfOper _Grl_	Unintended Operation	This output is logic true if the status of the circuit breaker has changed without detected command from the SCADA system or on the input "ExtSwitch"
CB1Pol_ Closed _Grl_	Closed	The filtered status signal for closed state of the circuit breaker
CB1Pol_ Opened _Grl_	Opened	The filtered status signal for opened state of the circuit breaker

Table 2-3 The binary output signals of the circuit breaker control function

4.2.3.3.2.3. On-line data

Visible values on the on-line data page:

SIGNAL TITLE	DIMENSION	EXPLANATION
Status	-	State of the CB (see Chapter 2.2.6)
Off Command	-	Off command impulse, the duration of which is defined by the parameter "Pulse duration"
On Command	-	On command impulse, the duration of which is defined by the parameter "Pulse duration"
Operation	-	An impulse with a duration of 150 ms at any operation of the circuit breaker
Unintended Operation	-	This output is logic TRUE if the status of the circuit breaker has changed without detected command from the SCADA system or on the input "ExtSwitch"
Opened	-	The filtered status signal for opened state of the circuit breaker
Closed	-	The filtered status signal for closed state of the circuit breaker
Operation counter	-	Resettable* counter that increments every time the Operation (see above) output gets active

*The operation counter can be reset on the device web page on-line menu.

Table 2-4 On-line data of the circuit breaker control function

4.2.3.3.2.4. Events

The following events are generated in the event list, as well as sent to SCADA according to the configuration.

EVENT	VALUE	EXPLANATION
Status	Intermediate,Off,On,Bad	CB state indication based on the received signals

Table 2-5 Event of the circuit breaker control function

4.2.3.3.2.5. Commands

The following table contains the issuable commands of the function block. The name of the command channel is used while working in the EuroCAP configuration tool, whereas the title is seen by the user on the device web page.

COMMAND CHANNEL	TITLE	RANGE	EXPLANATION
CB1Pol_Oper_Con_	Operation	Off,On	Issue open (off) or close (on) command on the corresponding outputs of the function block

Table 2-6 The command of the circuit breaker control function

4.2.3.3.2.6. Indication of the four states (Intermediate, On, Off, Bad)

To generate an active scheme on the local LCD, there is an internal status variable indicating the state of the circuit breaker. Different graphic symbols can be assigned to the values, the function block's events are generated also according to this status variable.

This integer status has four values based on the states of the **stValOn** and **stValOff** inputs of the function block.

INTEGER STATUS	TITLE	STVALON STATE	STVALOFF STATE	VALUE	EXPLANATION
CB1Pol_stVal_ISt_	Status	FALSE	FALSE	0: Intermediate	Integer status signal for indicating the state of the CB according to the corresponding inputs of the function block
		FALSE	TRUE	1: Off	
		TRUE	FALSE	2: On	
		TRUE	TRUE	3: Bad	

Table 2-7 State signals from the circuit breaker control function

4.2.3.3.3. Technical data

FUNCTION	VALUE	ACCURACY
Pulse time		< 3 ms

Table 2-8 The technical data of the circuit breaker control function

4.2.3.3.3.1. Notes for testing

If the commands get blocked from time to time during commissioning, it is advised to check how the conditions are fulfilled to issue commands on the function block. The following **three** conditions must be fulfilled at the same time:

- Local or Remote input is active appropriately
- The enabling input (EnaOff or EnaOn) of the issued command (off or on) is active
- (close/on command only) Synchro-check is OK (SynOK input is active)

If there are no conditions to be defined for any of these three (e.g. there is no synchro-check function present, so no valid signal can be provided to that input), the corresponding input can be connected to constant logical TRUE signal provided by the fixture output of the Common function block.

4.2.3.3.3.1.1. IEC 61850 commands

In several configurations the Interlocking and Control logical nodes may have the same prefix for CB and DC function blocks (**INTCILO#** and **SBwCSWI#** respectively where the '#' marks the instance number). This means that their instance number not necessarily corresponds to the actual function block:

- Example: if there are **2** DC and **1** CB function blocks in the same configuration where the former ones were added first, the instance number **#1** and **#2** will belong to the DC function blocks whereas number **#3** will belong to the CB function block even if it is the only CB control function in the device.
- Make sure to check which logical nodes belong to which function by checking the DOI description using the EuroCAP tool (right click the function block in the Logic editor)

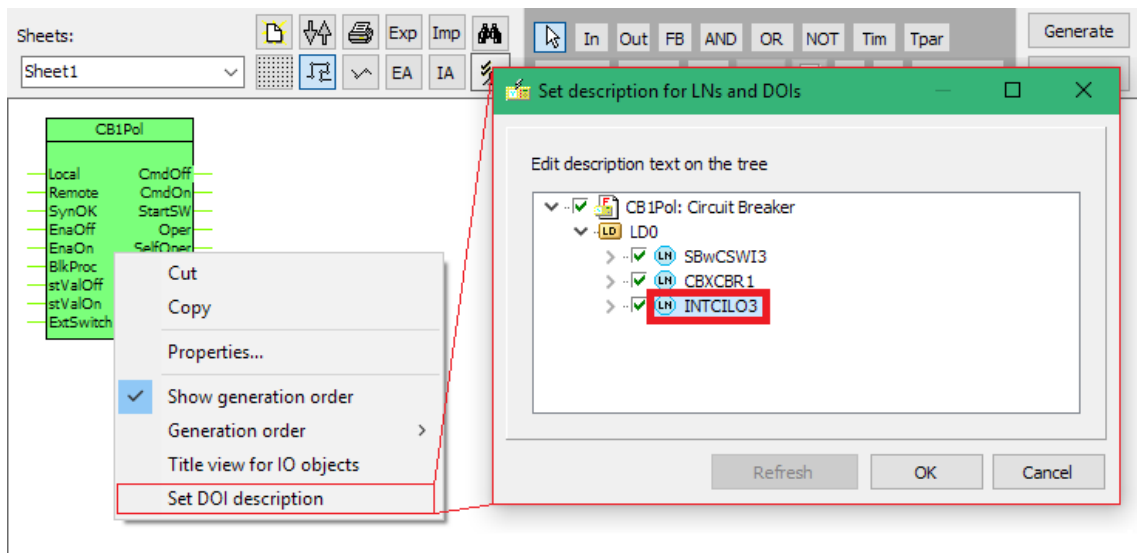
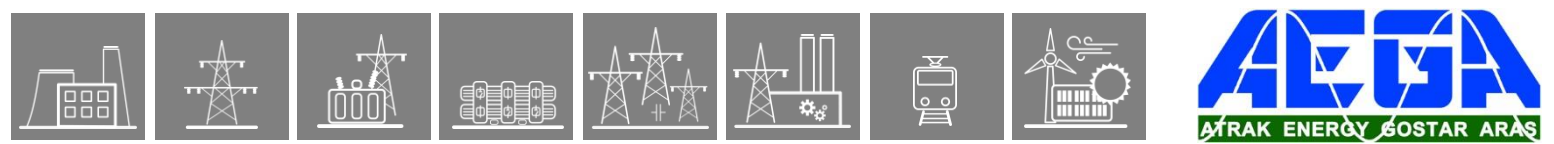

Figure 2-2 Checking the description of the Interlocking LN of the function block

In other cases, the two prefixes are given according to the type of the function block, so they are individual for each (i.e. **CBCILO#** and **CBCSW#** for circuit breaker and **DCCILO#** and **DCCSW#** for disconnector).



4.2.4. Disconnecter control function

4.2.4.1. Application

The disconnector control block can be used to integrate the disconnector control of the EuroProt+ device into the station control system and to apply active scheme screens of the local LCD of the device.

4.2.4.1.1. Mode of operation

The disconnector control block receives remote commands from the SCADA system and local commands from the local LCD of the device, performs the prescribed checking and transmits the commands to the disconnector. It processes the status signals received from the disconnector and offers them to the status display of the local LCD and to the SCADA system.

Main features:

- Local (LCD of the device) and Remote (SCADA) operation modes can be enabled or disabled individually.
- Interlocking functions can be programmed by the user applying the inputs “EnaOff” and “EnaOn”, using the graphic equation editor.
- Programmed conditions can be used to temporarily disable the operation of the function block using the graphic equation editor.
- The function block supports the control models prescribed by the IEC 61850 standard.
- All necessary timing tasks are performed within the function block:
 - Time limitation to execute a command
 - Command pulse duration
 - Filtering the intermediate state of the disconnector
 - Controlling the individual steps of the manual commands
- Sending open and close commands to the disconnector
- Operation counter
- Event reporting

4.2.4.2.2. Function I/O

This section describes briefly the analogue and digital inputs and outputs of the function block.

4.2.4.2.2.1. Binary input signals (graphed output statuses)

The conditions of the inputs are defined by the user, applying the graphic equation editor (logic editor). The part written in **bold** is seen on the function block in the logic editor.

BINARY INPUT SIGNAL	EXPLANATION
DisConn_ Local _GrO_	If this input is active, the disconnector can be controlled using the local LCD of the device.
DisConn_ Remote _GrO_	If this input is active, the disconnector can be controlled via remote communication channels of the SCADA system or the device web page ('commands' menu)
DisConn_ EnaOff _GrO_	The active state of this input enables the opening of the disconnector. The state is usually generated by the <i>interlocking conditions defined graphically by the user</i> .
DisConn_ EnaOn _GrO_	The active state of this input enables the closing of the disconnector. The state is usually generated by the <i>interlocking conditions defined graphically by the user</i> .
DisConn_ BlkProc _GrO_	The active state of this input blocks the operation of the disconnector. The conditions are defined graphically by the user.
DisConn_ stValOff _GrO_	Off (Opened) state of the disconnector.
DisConn_ stValOn _GrO_	On (Closed) state of the disconnector.

Table 2-2 The binary input signals of the disconnector control function

4.2.4.2.2.2. Binary output signals (graphed input statuses)

The binary output status signals of the differential protection function. Parts written in **bold** are seen on the function block in the logic editor.

BINARY OUTPUT SIGNAL	SIGNAL TITLE	EXPLANATION
DisConn_ CmdOff _Grl_	Off Command	Off command impulse, the duration of which is defined by the parameter "Pulse duration"
DisConn_ CmdOn _Grl_	On Command	On command impulse, the duration of which is defined by the parameter "Pulse duration"
DisConn_ Oper _Grl_	Operation	An impulse with a duration of 150 ms at any operation of the disconnector
DisConn_ Closed _Grl_	Closed	The filtered status signal for closed state of the disconnector
DisConn_ Opened _Grl_	Opened	The filtered status signal for opened state of the disconnector

Table 2-3 The binary output signals of the disconnector control function

4.2.4.2.2.3. On-line data

Visible values on the on-line data page:

SIGNAL TITLE	DIMENSION	EXPLANATION
Status	-	State of the DC (see Chapter 2.2.6)
Off Command	-	Off command impulse, the duration of which is defined by the parameter "Pulse duration"
On Command	-	On command impulse, the duration of which is defined by the parameter "Pulse duration"
Operation	-	An impulse with a duration of 150 ms at any operation of the disconnecter
Opened	-	The filtered status signal for opened state of the disconnecter
Closed	-	The filtered status signal for closed state of the disconnecter
Operation counter	-	Resettable* counter that increments every time the Operation (see above) output gets active

Table 2-4 On-line data of the disconnecter control function

*The operation counter can be reset on the device web page on-line menu.

4.2.4.2.2.4. Events

The following events are generated in the event list, as well as sent to SCADA according to the configuration.

EVENT	VALUE	EXPLANATION
Status	Intermediate,Off,On,Bad	DC state indication based on the received status signals

Table 2-5 Event of the disconnecter control function

4.2.4.2.2.5. Commands

The following table contains the issuable commands of the function block. The name of the command channel is used while working in the EuroCAP configuration tool, whereas the title is seen by the user on the device web page.

COMMAND CHANNEL	TITLE	RANGE	EXPLANATION
DisConn_Oper_Con_	Operation	Off,On	Issue open (off) or close (on) command on the corresponding outputs of the function block

Table 2-6 The command of the disconnecter control function

4.2.4.2.2.6. Indication of the four states (Intermediate, On, Off, Bad)

To generate an active scheme on the local LCD, there is an internal status variable indicating the state of the disconnecter. Different graphic symbols can be assigned to the values, the function block's events are generated also according to this status variable.

This integer status has four values based on the states of the **stValOn** and **stValOff** inputs of the function block.

INTEGER STATUS	TITLE	STVALON STATE	STVALOFF STATE	VALUE	EXPLANATION
DisConn_stVal_ISt_	Status	FALSE	FALSE	0: Intermediate	Integer status signal for indicating the state of the DC according to the corresponding inputs of the function block
		FALSE	TRUE	1: Off	
		TRUE	FALSE	2: On	
		TRUE	TRUE	3: Bad	

Table 2-7 State signals from the disconnecter control function

4.2.4.2.3. Technical data

FUNCTION	VALUE	ACCURACY
Operate time		±5% or ±15 ms, whichever is greater

Table 2-8 The technical data of the disconnecter control function

4.2.4.2.3.1. Notes for testing

If the commands get blocked from time to time during commissioning, it is advised to check how the conditions are fulfilled to issue commands on the function block. The following **three** conditions must be fulfilled at the same time:

- Local or Remote input is active appropriately
- The enabling input (EnaOff or EnaOn) of the issued command (off or on) is active

If there are no conditions to be defined for any of these two (e.g. there is no difference made between local/remote control), the corresponding input can be connected to constant logical TRUE signal provided by the fixture output of the Common function block.

4.2.4.2.3.1.1. IEC 61850 commands

In several configurations the Interlocking and Control logical nodes may have the same prefix for DC and CB function blocks (**INTCILO#** and **SBwCSWI#** respectively where the '#' marks the instance number). This means that their instance number not necessarily corresponds to the actual function block:

- Example: if there are **1** CB and **1** DC function blocks in the same configuration where the former was added first, the instance number **#1** will belong to the CB function block whereas number **#2** will belong to the DC function block even if it is the only DC control function in the device.
- Make sure to check which logical nodes belong to which function by checking the DOI description using the EuroCAP tool (right click the function block in the Logic editor)

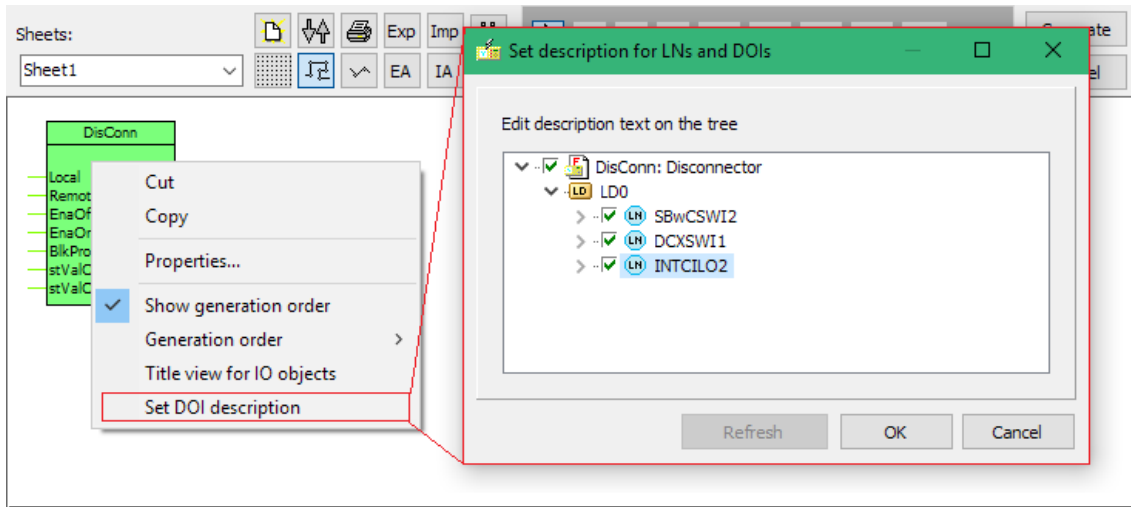

Figure 2-2 Checking the description of the Interlocking LN of the function block

In other cases, the two prefixes are given according to the type of the function block, so they are individual for each (i.e. **DCCILO#** and **DCCSW#** for disconnector and **CBCILO#** and **CBCSW#** for circuit breaker).

4.2.4.3. Example logic

A simple example can be seen below of how to insert the function block in the user logic using the EuroCAP Logic Editor:

- The Local/Remote state of the device is provided by the Common function block which is present in all configurations
- The connections to the BIn and BOut elements show the connections to the physical input and output contacts
- The highlighted signal leading to the EnaOff and EnaOn inputs is the realization of the interlocking logic. In this case the disconnecter can operate only if the circuit breaker is opened.

The opened state of the CB is now indicated by its filtered 'Opened' signal which is active only if the CB is open and there is no state error (or intermediate state) of it.

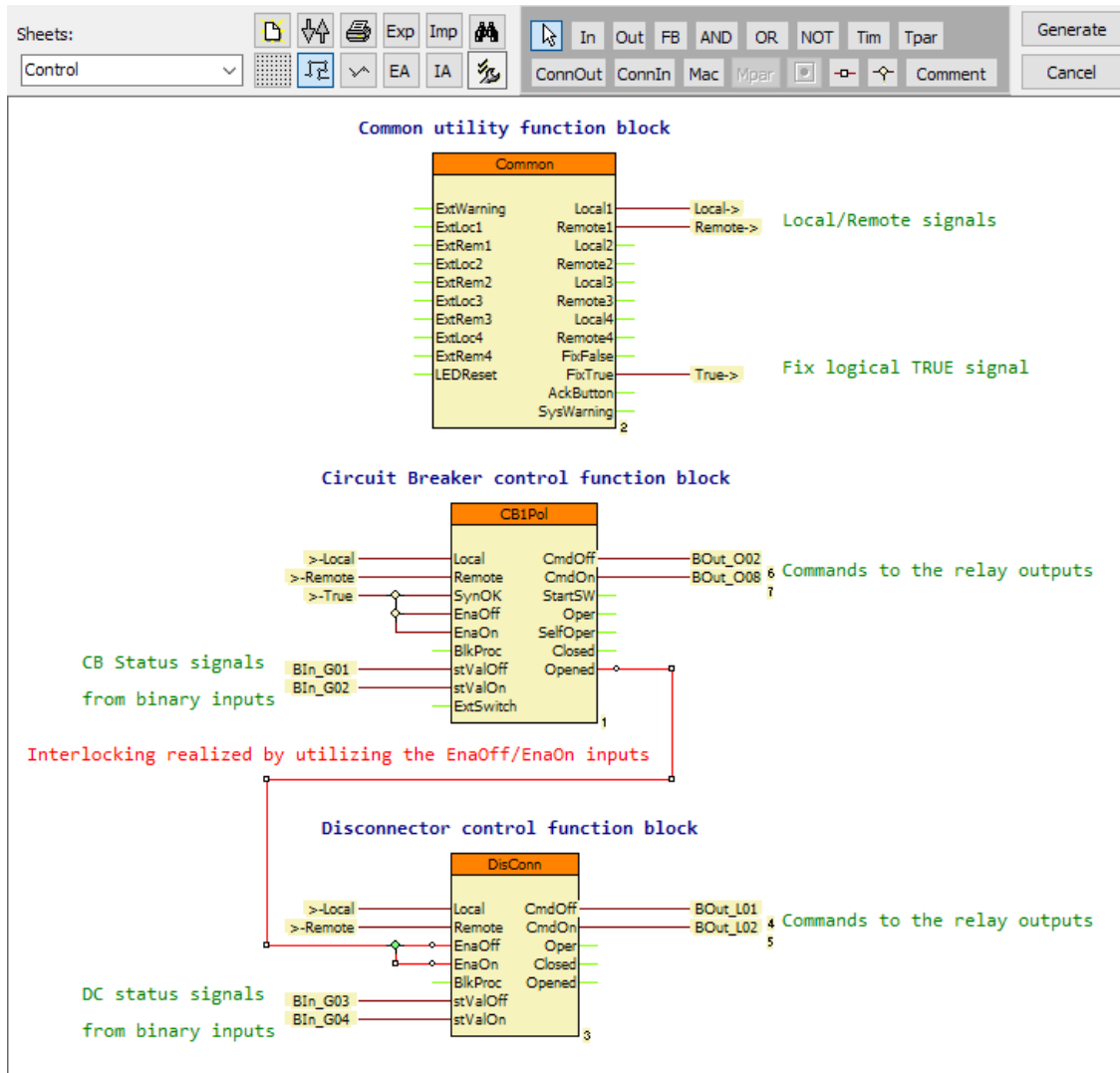

Figure 3-1 Inserting the disconnecter function block into the logic (example)

4.2.5.2. Ethernet Links function overview

The graphic appearance of the function block is shown on [Figure 2-1](#). These blocks show all binary input and output status signals, which are applicable in the graphic equation editor.

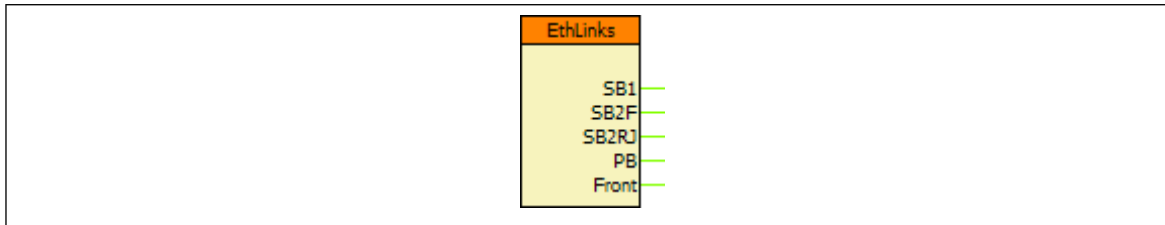

Figure 2-1 Graphic appearance of the function block of the ethernet links function

4.2.5.2.1. Settings

There are no settings for this function block.

4.2.5.2.2. Function I/O

This section describes briefly the analogue and digital inputs and outputs of the function block.

This function block owns only binary output signals.

4.2.5.2.2.1. Binary output signals (graphed input statuses)

The binary output status signals of the Ethernet Links function. **Parts written in bold** are seen on the function block in the logic editor.

BINARY OUTPUT SIGNAL	SIGNAL TITLE	EXPLANATION
EthLnk_ SB1 _Grl_	Station Bus1	Active if the first (upper) fiber optic port of the CPU module has an active connection.
EthLnk_ SB2F _Grl_	Station Bus2 – Fiber	Active if the second (middle) fiber optic port of the CPU module has an active connection.
EthLnk_ SB2RJ _Grl_	Station Bus2 –RJ4	Active if the RJ45 port of the CPU module has an active connection.
EthLnk_ PB _Grl_	Process Bus	Active if the third (lower) fiber optic port of the CPU module has an active connection
EthLnk_ Front _Grl_	RJ45/EOB on front panel	Active if the front RJ45 port (or EOB) has an active connection

Table 2-1 The binary output status signals of the ethernet links function

4.2.5.2.2.2. On-line data

Visible values on the on-line data page:

SIGNAL TITLE	DIMENSION	EXPLANATION
Station Bus1	-	Active if the first (upper) fiber optic port of the CPU module has an active connection.
Station Bus2 – Fiber	-	Active if the second (middle) fiber optic port of the CPU module has an active connection.
Station Bus2 –RJ4	-	Active if the RJ45 port of the CPU module has an active connection.
Process Bus	-	Active if the third (lower) fiber optic port of the CPU module has an active connection
RJ45/EOB on front panel	-	Active if the front RJ45 port (or EOB) has an active connection

Table 2-2 The measured analogue values of the ethernet links function

4.2.5.2.2.3. Events

The following events are generated in the event list, as well as sent to SCADA according to the configuration.

EVENT	VALUE	EXPLANATION
Station Bus1	off, on	Active if the first (upper) fiber optic port of the CPU module has an active connection.
Station Bus2 – Fiber	off, on	Active if the second (middle) fiber optic port of the CPU module has an active connection.
Station Bus2 –RJ4	off, on	Active if the RJ45 port of the CPU module has an active connection.
Process Bus	off, on	Active if the third (lower) fiber optic port of the CPU module has an active connection
RJ45/EOB on front panel	off, on	Active if the front RJ45 port (or EOB) has an active connection

Table 2-3 Events of the ethernet links function

4.2.5.2.3. Technical data

There is no technical data to add.

4.2.6. Trip Circuit Supervision

4.2.6.1. Introduction

This document describes the applicable hardware and provides guidelines for usage in the device configuration.

4.2.6.1.1. Operation principle

The trip circuit supervision is utilized for checking the integrity of the circuit between the trip coil and the tripping output of the protection device.

This is realized by injecting a small DC current (around 1-5 mA) into the trip circuit. If the circuit is intact, the current flows, causing an active signal to the opto coupler input of the trip contact.

The state of the input is shown on the devices' binary input listing among the other binary inputs, and it can be handled like any other of them (it can be added to the user logic, etc.)

4.2.6.1.2. Applicable modules

The following modules contain trip outputs with trip circuit supervision. The information here is restricted to the trip circuit supervision only. For more details please refer to the EuroProt+ Hardware description from which these were extracted. Note that there are other modules without trip circuit supervision, those are not listed here.

Table 1-1 Modules with Trip Circuit Supervision

MODULE TYPE	TRIP+4201	TRIP+2101	TRIP+2201	PSTP+4201	PSTP+2101
CHANNEL NUMBER	4	4	4	2	2
RATED VOLTAGE	24 V DC and 48 V DC	110 V DC	220 V DC	24 V DC and 48 V DC and 60 V DC	110 V DC and 220 V DC
THERMAL WITHSTAND VOLTAGE	72 V DC	150 V DC	242 V DC	72 V DC	242 V DC

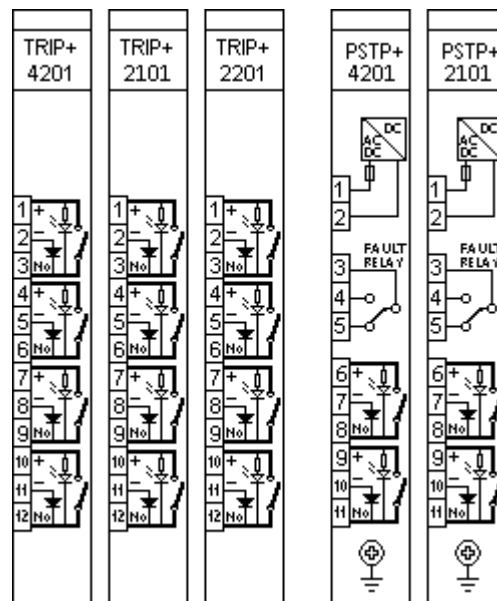

Figure 1-1 I/O arrangement of the modules with TCS

4.2.6.2. Hardware application

4.2.6.2.1. Wiring

The wiring of these modules can be 2-wire or 3-wire. The TCS – Trip Circuit Supervision function is active with both methods.



The voltage of the "No" contact is maximized at 15 V by a Zener-diode. Make sure that the voltage caused by the resistance of the circuit breaker and the injected current from the TRIP+ module does not reach 10 V. In case of PSTP+ modules, this voltage is 8 V (PSTP+/4201) and 13 V (PSTP+/2101).



Our TRIP+ modules are made to switch DC circuits. **Using reversed polarity or AC voltage can cause the damage of the internal circuits.**

4.2.6.2.1.1. 3-wire TRIP+ wiring methods

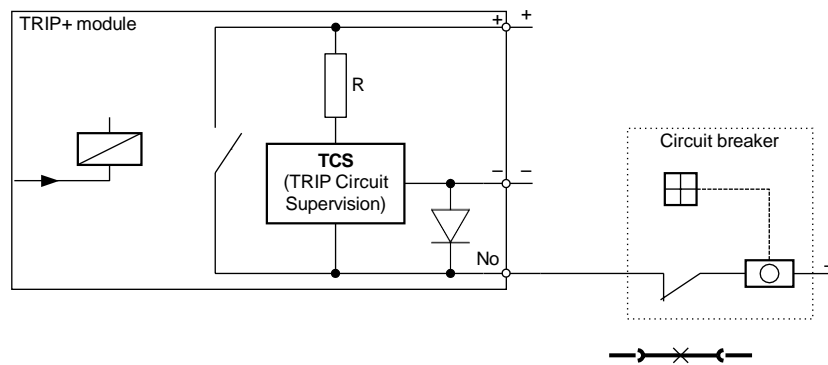

Figure 2-1 3-wire TRIP+ wiring

It is possible to use parallel connected TRIP+ modules. In this case the negative contacts must be common.

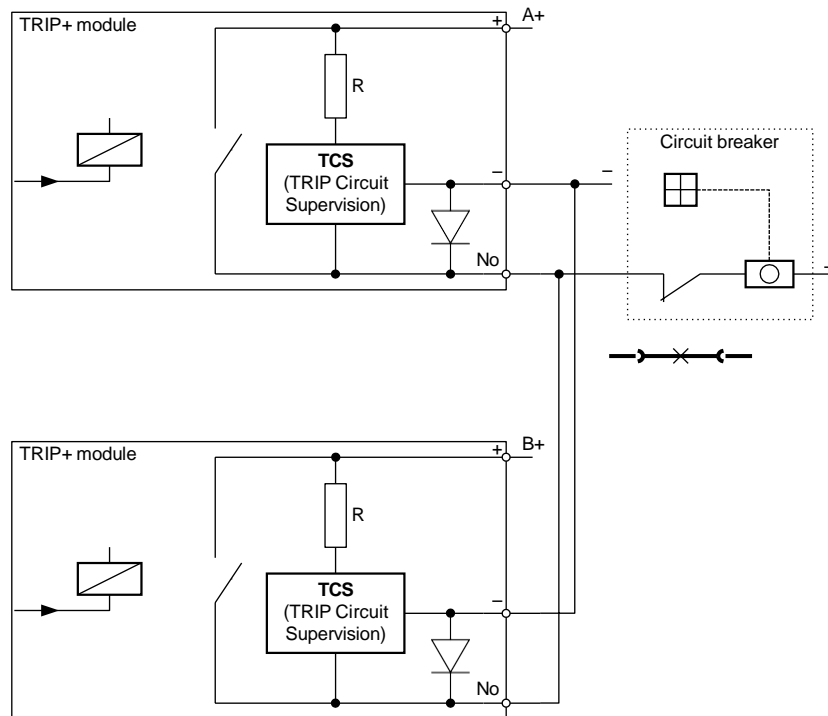

Figure 2-2 3-wire TRIP+ wiring using parallel connected TRIP+ modules

4.2.6.2.1.2. 2-wire TRIP+ wiring methods

If it is necessary, you can also wire the TRIP+ modules using only the “+” and the “No” contacts.

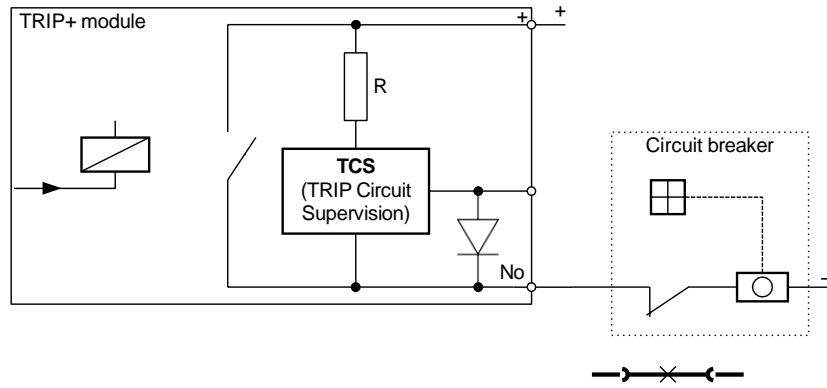

Figure 2-3 2-wire TRIP+ wiring

It is possible to use parallel connected TRIP+ modules.

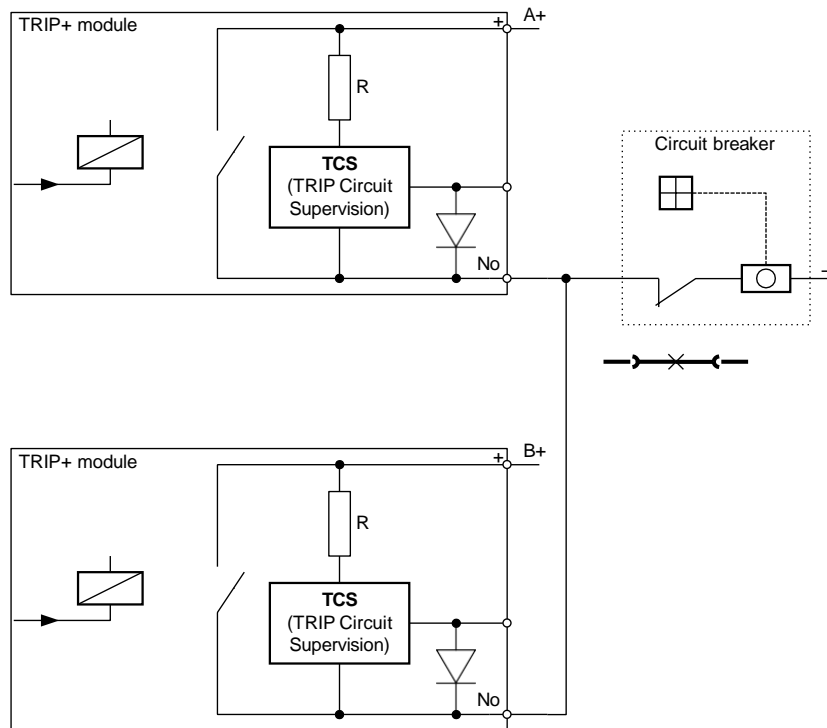

Figure 2-4 2-wire TRIP+ wiring using parallel connected TRIP+ modules

If the circuit breaker needs two-pole switching, TRIP+ modules can be connected series as you can see in [Figure 2-5](#).

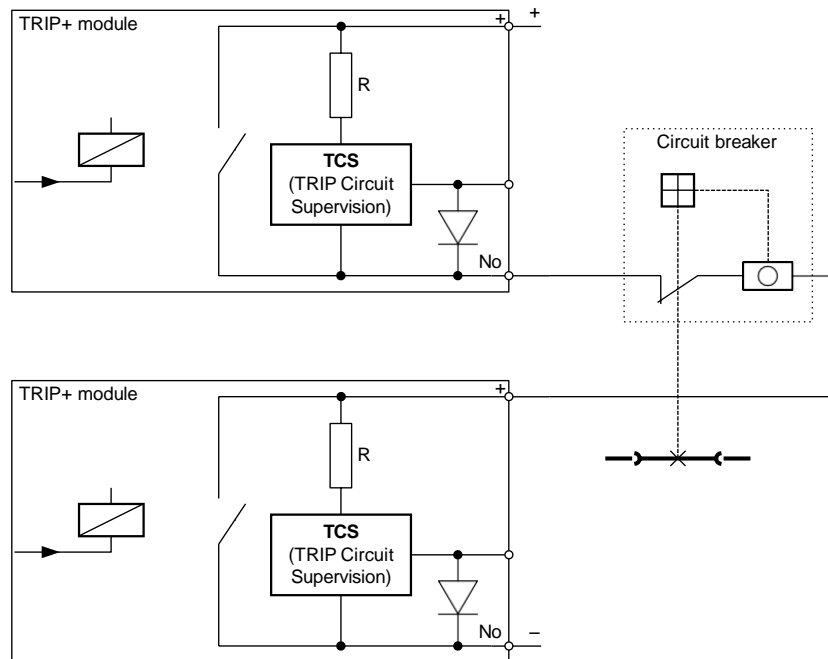

Figure 2-5 2-wire TRIP+ wiring using series connected TRIP+ modules

4.2.6.2.2. TCS signal handling

The Trip Circuit Supervision detects broken trip circuit if the current flowing through the trip coil is below 1 mA or (in case of 3-wire wirings) the voltage on it is above 8-10-13 V (depending on the module).

In Chapter [2.3](#) there are calculated maximum values for the resistance of the trip coil. If these values are exceeded, the TCS might consider the trip circuit broken even if it is intact.

To solve this, there are two ways:

- Using the 2-wire wiring method*:** leaving out/disconnecting the DC- part of the TRIP wiring may solve the issue.
Note that in this case the voltage is not maximized on 15 V, so **the used voltage (up to 220 Vdc) will appear on the “NO” pin**. Caution is advised when touching the wiring in this case.
- Usage of modules without TCS:** if the TCS is not a requirement (e.g. in backup protections), it can be simply left out by opting for the appropriate modules (such as PSTP+/2131 or TRIP+/21F1) while ordering.

**The inputs of some relay testers might sense the states of the Trip contacts active even if they are not. In such cases the “-“ pin must be wired in for the tests.*



4.2.6.2.3. Technical data

The following tables contain information according to the wiring connections described in Chapter 2.1.

Table 2-1 Technical data for the TRIP+ modules

MODULE TYPE	TRIP+4201	TRIP+2101	TRIP+2201	
VALUE OF R RESISTOR ($\pm 10\%$)	10 k Ω	73 k Ω	130 k Ω	
INJECTED CURRENT AT "NO" CONTACT	2.4 mA @ 24 V DC 4.8 mA @ 48 V DC	1.5 mA @ 110 V DC	1.7 mA @ 220 V DC	
MAXIMUM RESISTANCE OF THE TRIP COIL	3-WIRE WIRING (MAX. 10 V)	11.8 k Ω @ 24 V DC 3.7 k Ω @ 48 V DC	9.7 k Ω @ 110 V DC 8.4 k Ω @ 125 V DC	8.1 k Ω @ 220 V DC
	3-WIRE WIRING WITH IN PARALLEL (MAX. 10 V)	5.9 k Ω @ 24 V DC 1.8 k Ω @ 48 V DC	4.8 k Ω @ 110 V DC 4.2 k Ω @ 125 V DC	4 k Ω @ 220 V DC
	2-WIRE METHOD (1 mA MIN. CURRENT)	14 k Ω @ 24 V DC 38 k Ω @ 48 V DC	37 k Ω @ 110 V DC 52 k Ω @ 125 V DC	90 k Ω @ 220 V DC

The PSTP+ modules work based on current generator principle, so the calculations for these are based on the necessary minimum current and the allowed maximum voltage.

Table 2-2 Technical data for the PSTP+ modules

MODULE TYPE	PSTP+4201	PSTP+2101	
INJECTED CURRENT AT "NO" CONTACT	1.5 mA	1.5 mA	
MAXIMUM RESISTANCE OF THE TRIP COIL	3-WIRE WIRING (1 mA CURRENT)	8 k Ω (max. 8 V)	13 k Ω (max. 13 V)
	3-WIRE WIRING IN PARALLEL	4 k Ω (max. 8 V)	6.5 k Ω (max. 13 V)
	2-WIRE METHOD (1 mA MIN. CURRENT)	24 k Ω @ 24 V DC 48 k Ω @ 48 V DC 60 k Ω @ 60 V DC	110 k Ω @ 110 V DC 220 k Ω @ 220 V DC

4.2.6.3. Software application

4.2.6.3.1. Binary inputs



The **TCS input is active if the trip circuit is intact**, so the logical '0' or FALSE signal of the input means that either the trip circuit is broken, or it connects to high resistance.

The TCS signals are shown the same way as other binary inputs are in the device: they can be seen in the **on-line data** menu on the local HMI or the device web page, and they can be utilized just like any other binary input when editing the device configuration with EuroCAP software.

The names/titles of the inputs follow the occupied slot of the TRIP module (if it is in Slot **N**, the TCS contact is named BIn_#N##).

4.2.6.3.2. The TCS macro

In most cases the trip circuit is tripped along with the circuit breaker as well. In situations like this the TCS input would signal a broken trip circuit (logical '0' or FALSE) unnecessarily. To avoid this, the status signals of the CB are to be used combined with the TCS input signal so that it will be evaluated only when the CB is closed.

The TCS macro incorporates this logic for two separate TCS inputs for one CB (see [Figure 3-2](#) for the two TCS inputs and the CB status signal inputs). The outputs are the failure signals for each connected TCS input.

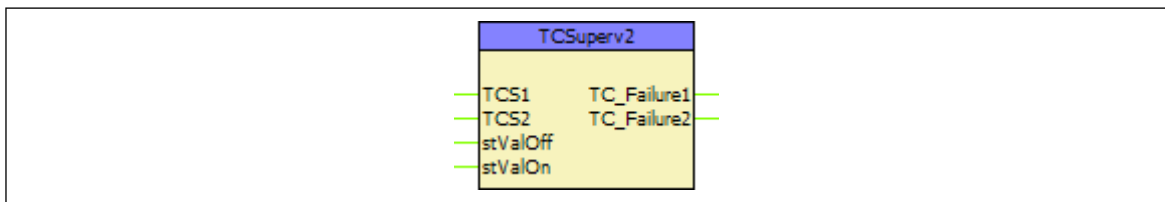

Figure 3-1 Graphic appearance of the Trip Circuit Supervision macro



The internal logic of the macro can be seen on [Figure 3-2](#) below. Both outputs have a fixed pick delay of 1000 ms. Note that **here the outputs are active if the trip circuit is broken**. For a CB with only 1 trip circuit it is enough to simply leave the **TCS2** input open (naturally in this case the TC_Failure2 output cannot be used).

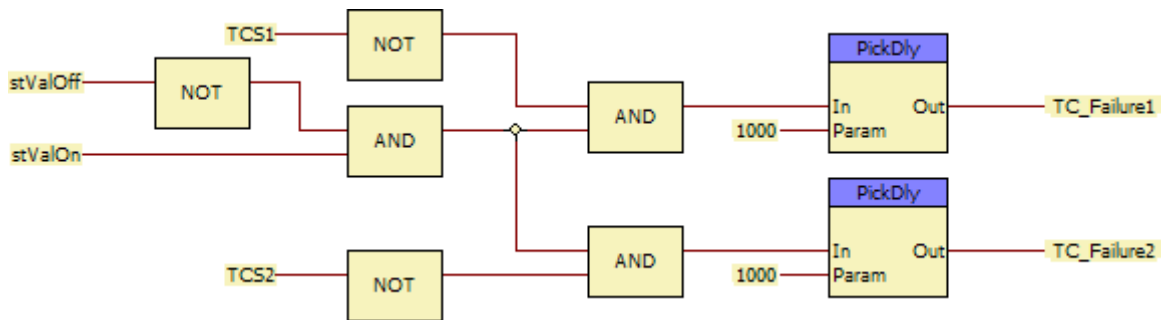
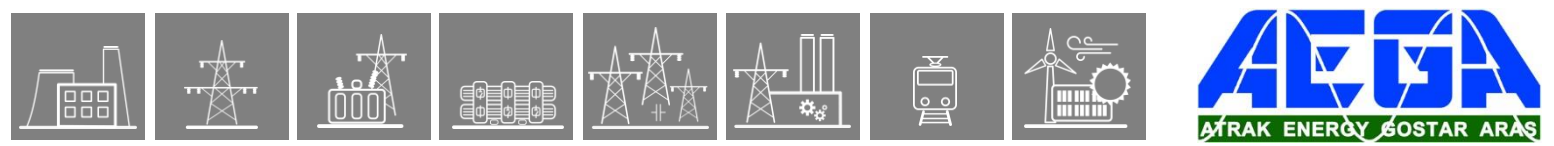

Figure 3-2 Internal logic of the Trip Circuit Supervision macro



4.2.6.3.2.1. Binary input signals

The following table explains the binary input signals of the macro.

Table 3-1 Binary input signals of the Trip Circuit Supervision macro

BINARY INPUT SIGNAL	EXPLANATION
TCS1	Connect here the first TCS binary input
TCS2	Connect here the second TCS binary input
stValOff	CB Off/Open signal
stValOn	CB On/Closed signal

4.2.6.3.2.2. Binary output signals

The following table explains the binary output signals of the macro.

Table 3-2 Binary output signals of the Trip Circuit Supervision macro

BINARY OUTPUT SIGNAL	EXPLANATION
TC_Failure1	Failure on the first circuit
TC_Failure2	Failure on the second circuit

Note that these are the outputs of a macro, and not a function block, so they must be connected to a physical or a logical output (ConnOut, create status) to make them usable in other parts of the configuration. For further information please refer to the EuroCAP software description.

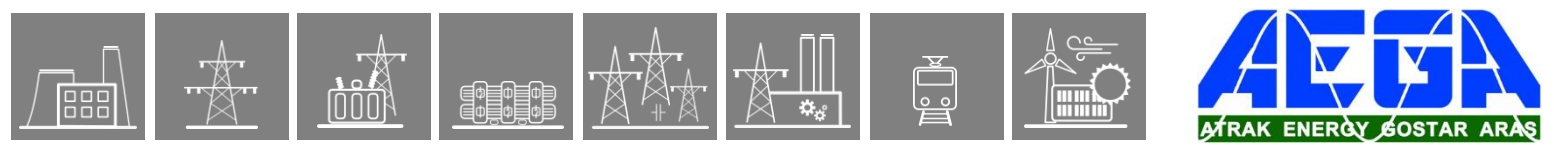

4.2.7. Dead Line Detection Function

4.2.7.1. Application

The “Dead Line Detection” (DLD) function generates a signal indicating the dead or live state of the line. Additional signals are generated to indicate if the phase voltages and phase currents are above the pre-defined limits.

4.2.7.1.1. Mode of Operation

The task of the “Dead Line Detection” (DLD) function is to decide the Dead line/Live line state.

Criteria of “Dead line” state: all three phase voltages are below the voltage setting value AND all three currents are below the current setting value.

Criteria of “Live line” state: all three phase voltages are above the voltage setting value.

4.2.7.1.2. Structure of the Algorithm

Figure 1-1 shows the structure of the dead line detection algorithm.

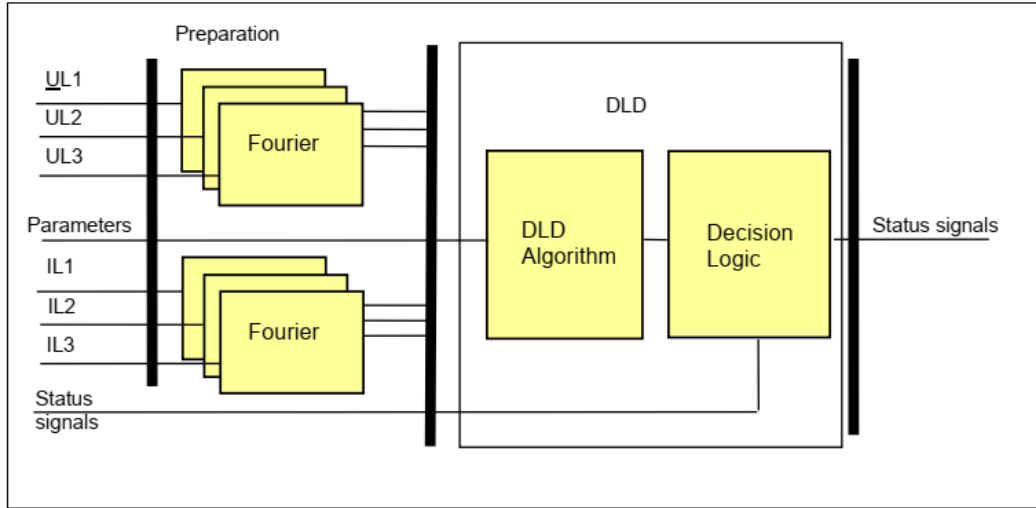

Figure 1-1 Structure of the dead line detection algorithm

For the preparation phase:

The **inputs** are

- the sampled values of the three phase voltages (UL1, UL2, UL3) and three phase currents (IL1, IL2, IL3),
- parameters.

The **outputs** are

- the fundamental Fourier components of the three phase voltages (UL1, UL2, UL3) and three phase currents (IL1, IL2, IL3).

For the DLD function:

The **inputs** are

- the fundamental Fourier components of the three phase voltages (UL1, UL2, UL3) and three phase currents (IL1, IL2, IL3),
- parameters,
- status signals.

The **software modules** of the dead line detection function are:

Fourier calculations

These modules calculate the basic Fourier components of the phase currents and phase voltages individually. These modules belong to the preparation phase.

Dead Line Detection

This module decides if the “Live line condition” (Line_OK) or the “DeadLine condition” is fulfilled.

Decision logic

The decision logic module combines the status signals to generate the outputs of the function.

The following description explains the details of the individual components.

4.2.7.1.3. The Fourier Calculation (Fourier)

These modules calculate the basic Fourier current components of the phase voltages and phase currents individually. These modules belong to the preparation phase.

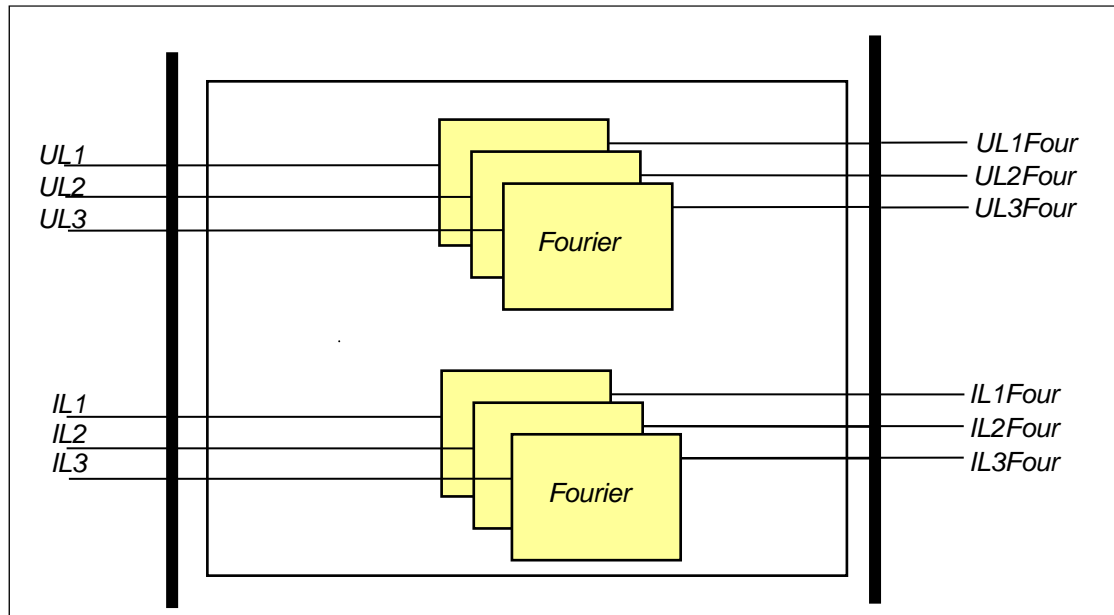

Figure 1-2 Principal scheme of the Fourier calculation

The **inputs** are the sampled values of:

- the three phase voltages (UL1, UL2, UL3)
- the three phase currents (IL1, IL2, IL3)

The **outputs** are:

- the basic Fourier components of the analyzed voltages (UL1Four, UL2Four, UL3Four),
- the basic Fourier components of the analyzed currents (IL1Four, IL2Four, IL3Four).

4.2.7.1.4. The Dead Line Detection Algorithm (Dead Line Detection)

This module decides if the “Live line condition” (Line_OK) or the “DeadLine condition” is fulfilled.

The **inputs** are

- the basic Fourier components of the phase voltages (UL1Four, UL2Four, UL3Four),
- the basic Fourier components of the phase currents (IL1Four, IL2Four, IL3Four),
- status signals,
- parameters.

The **outputs** are the internal status signals of the function. These indicate the “DeadLine condition” or the “Live line condition” (Line_OK) state.

Criteria of “Dead line” state: all three phase voltages are below the voltage setting value AND all three currents are below the current setting value.

Criteria of “Live line” state: all three phase voltages are above the voltage setting value.

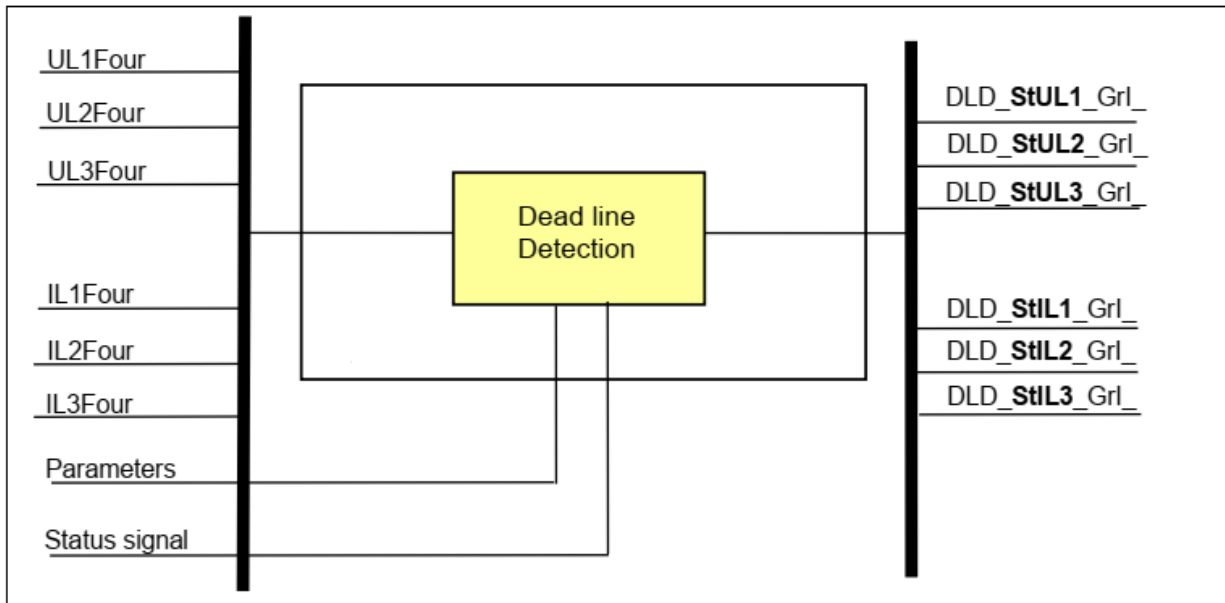
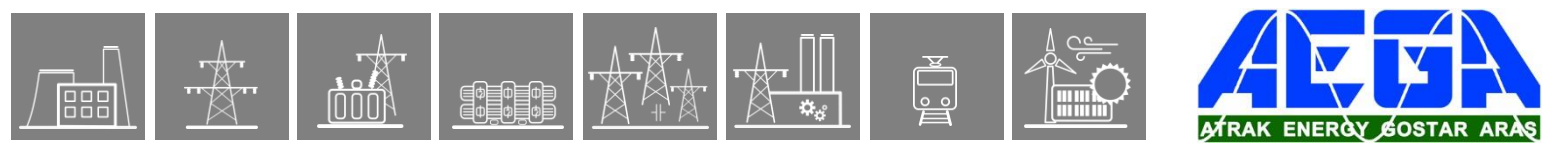

Figure 1-3 Principal scheme of the dead line detection function



Enumerated parameters

Table 1-1 The enumerated parameters of the dead line detection function

TITLE	DIM	RANGE	STEP	DEFAULT	EXPLANATION
Operation	-	Off, On	-	Off	Parameter for enabling the function

Integer parameters

Table 1-2 The integer parameters of the dead line detection function

TITLE	DIM	RANGE	STEP	DEFAULT	EXPLANATION
Min Operate Voltage	%	10 – 100	1	60	Voltage setting for “Dead line” state criteria.
Min Operate Current	%	2 – 100	1	10	Current setting for “Dead line” state criteria.

Binary status signals

The dead line detection function has a binary input signal, which serves the purpose of disabling the function. **The conditions of disabling are defined by the user, applying the graphic equation editor.**

Table 1-3 The binary input signal of the dead line detection function

BINARY STATUS SIGNAL	SIGNAL TITLE	EXPLANATION
DLD_Blk_GrO_	Block	Input used to disable the function

The **binary output status signals** of the residual dead line detection function are listed in [Table 1-4](#).

Table 1-4 The binary output status signals of the dead line detection function

BINARY OUTPUT SIGNAL	SIGNAL TITLE	EXPLANATION
DLD_StUL1_GrI_	Start UL1	The voltage of phase L1 is above the setting limit
DLD_StUL2_GrI_	Start UL2	The voltage of phase L2 is above the setting limit
DLD_StUL3_GrI_	Start UL3	The voltage of phase L3 is above the setting limit
DLD_StIL1_GrI_	Start IL1	The current of phase L1 is above the setting limit
DLD_StIL2_GrI_	Start IL2	The current of phase L2 is above the setting limit
DLD_StIL3_GrI_	Start IL3	The current of phase L3 is above the setting limit

4.2.7.1.5. The Decision Logic (Decision logic)

The decision logic module combines status signals, binary and enumerated parameters to generate the dead line or live line status signals.

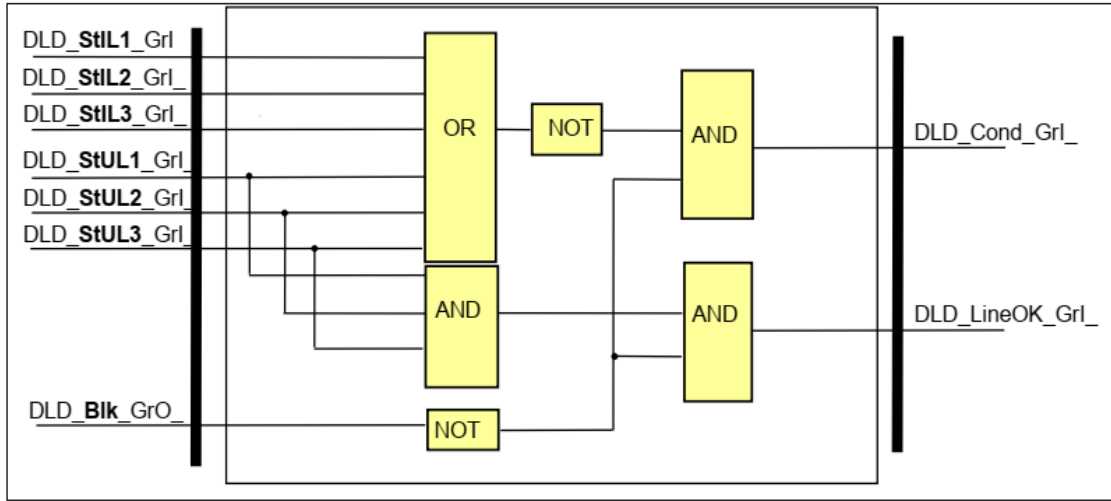

Figure 1-4 The logic scheme of the decision logic

Table 1-5 The binary input status signal of the decision logic

BINARY INPUT SIGNAL	SIGNAL TITLE	EXPLANATION
DLD_StUL1_Grl_	Start UL1	The voltage of phase L1 is above the setting limit
DLD_StUL2_Grl_	Start UL2	The voltage of phase L2 is above the setting limit
DLD_StUL3_Grl_	Start UL3	The voltage of phase L3 is above the setting limit
DLD_StIL1_Grl_	Start IL1	The current of phase L1 is above the setting limit
DLD_StIL2_Grl_	Start IL2	The current of phase L2 is above the setting limit
DLD_StIL3_Grl_	Start IL3	The current of phase L3 is above the setting limit

Binary status signals

The function has a binary input signal, which serves the purpose of disabling the function. **The conditions of disabling are defined by the user, applying the graphic equation editor.**

Table 1-6 The binary input signal of the dead line detection function

BINARY STATUS SIGNAL	SIGNAL TITLE	EXPLANATION
DLD_Blk_GrO_	Block	Input for disabling the function

Table 1-7 The binary output status signals of the dead line detection function

BINARY OUTPUT SIGNAL	SIGNAL TITLE	EXPLANATION
DLD_DeadLine_Grl_	DeadLine condition	The requirements of "DeadLine condition" are fulfilled
DLD_LineOK_Grl_	LineOK condition	The requirements of "Live line condition" (LineOK) are fulfilled

4.2.7.2. DeadLine Detection Function Overview

The graphic appearance of the dead line detection function block is shown in [Figure 2-1](#). This block shows all binary input and output status signals that are applicable in the graphic equation editor.

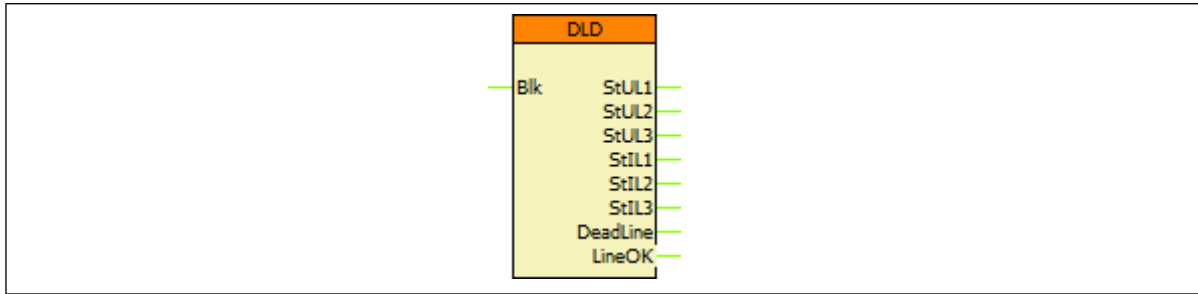

Figure 2-1 The function block of the residual instantaneous overcurrent protection

4.2.7.2.1. Settings

4.2.7.2.1.1. Parameters

The available parameters are listed below in order of their appearance in the *parameters* menu. If the setting range of a parameter should be extended, contact Protecta Support.

Table 2-1 Parameters of the dead line detection function

TITLE	DIM	RANGE	STEP	DEFAULT	EXPLANATION
Operation	-	Off, On	-	Off	Parameter for enabling the function
Min Operate Voltage	%	10 – 100	1	60	Voltage setting for “Dead line” state criteria.
Min Operate Current	%	2 – 100	1	10	Current setting for “Dead line” state criteria.

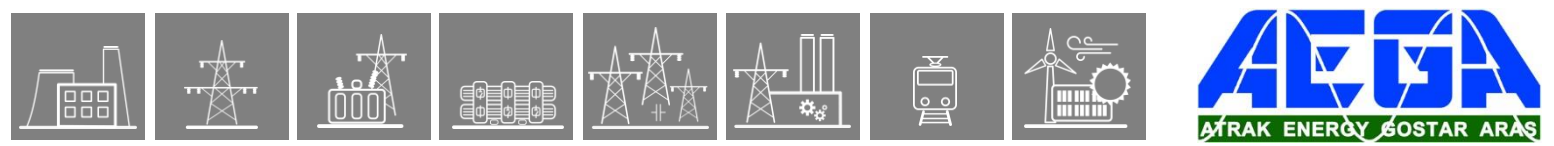

4.2.7.2.2. Function I/O

This section briefly describes the analogue and digital inputs and outputs of the function block.

4.2.7.2.2.1. Analogue inputs

The analog inputs are the sampled values of the three phase voltages and the three phase currents.

4.2.7.2.2.2. Binary input signals (graphed output statuses)

The conditions of the binary inputs are defined by the user, applying the graphic equation editor (*Logic Editor*). Parts written in **bold** are seen on the left side of the function block in the Logic editor.

Table 2-2 The binary input signals of the dead line detection function

BINARY INPUT SIGNAL	SIGNAL TITLE	EXPLANATION
DLD_ Blk _GrO_	Block	Input for disabling the function

4.2.7.2.2.3. Binary output signals (graphed input statuses)

These signals can be used in EuroCAP to assign to LED, user LCD object etc. Parts written in **bold** are seen on the right side of the function block in the *Logic Editor*.

Table 2-3 The binary output signals of the dead line detection function

BINARY OUTPUT SIGNAL	SIGNAL TITLE	EXPLANATION
DLD_ StUL1 _GrI_	Start UL1	The voltage of phase L1 is above the setting limit
DLD_ StUL2 _GrI_	Start UL2	The voltage of phase L2 is above the setting limit
DLD_ StUL3 _GrI_	Start UL3	The voltage of phase L3 is above the setting limit
DLD_ StIL1 _GrI_	Start IL1	The current of phase L1 is above the setting limit
DLD_ StIL2 _GrI_	Start IL2	The current of phase L2 is above the setting limit
DLD_ StIL3 _GrI_	Start IL3	The current of phase L3 is above the setting limit
DLD_ DeadLine _GrI_	DeadLine condition	The requirements of "DeadLine condition" are fulfilled
DLD_ LineOK _GrI_	LineOK condition	The requirements of "Live line condition" (LineOK) are fulfilled

4.2.7.2.2.4. Online data

The following values are visible in the *online data* page.

Table 2-4 Online data of the dead line detection function

SIGNAL TITLE	DIMENSION	EXPLANATION
DeadLine condition	-	The requirements of "DeadLine condition" are fulfilled
LineOK condition	-	The requirements of "Live line condition" are fulfilled

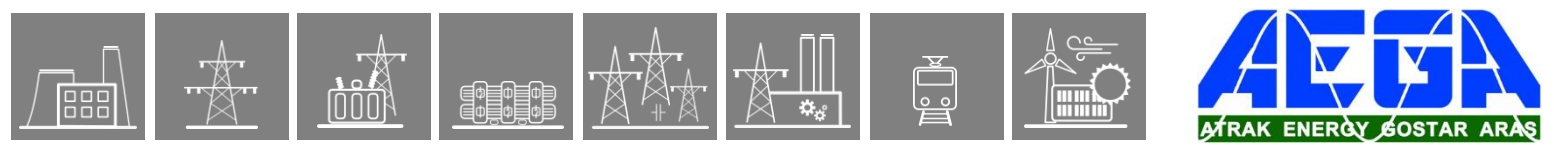

4.2.7.2.2.5. Events

There are no events generated for this function block.

4.2.7.2.3. Technical Data

Table 2-5 Technical data of the dead line detection function

FUNCTION	VALUE	ACCURACY
Pick-up voltage		1%
Operation time	< 20 ms	
Reset ratio	0.95	

4.2.7.2.4. Notes for Testing

This function does not generate events on its own. To create them, another function block, the GGIO16 custom event function block must be utilized, see its description for more information.

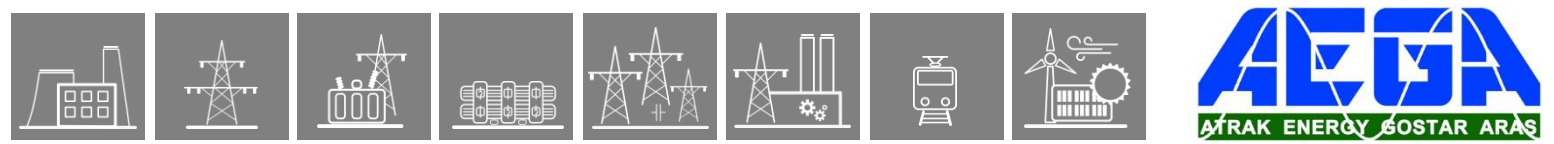

4.2.8. Voltage transformer supervision function

The voltage transformer supervision function generates a signal to indicate an error in the voltage transformer secondary circuit. This signal can serve, for example, as a warning, indicating disturbances in the measurement, or it can disable the operation of the distance protection function if appropriate measured voltage signals are not available for a distance decision.

The voltage transformer supervision function is designed to detect faulty asymmetrical states of the voltage transformer circuit caused, for example, by a broken conductor in the secondary circuit.

(Another method for detecting voltage disturbances is the supervision of the auxiliary contacts of the miniature circuit breakers in the voltage transformer secondary circuits. This function is not described here.)

The user has to generate graphic equations for the application of the signal of this voltage transformer supervision function.

This function is interconnected with the “dead line detection function”. Although the dead line detection function is described fully in a separate document, the explanation necessary to understand the operation of the VT supervision function is repeated also in this document.

4.2.8.1. Mode of operation

4.2.8.1.1. “Dead line detection” (DLD) function - modes of operation

The voltage transformer supervision function is based on the “Dead line detection” (DLD) function, the task of which is to decide the Dead line/Live line state.

Criteria of “Dead line” state: all three phase voltages are below the preset voltage value AND all three currents are below the preset current value.

Criteria of “Live line” state: all three phase voltages are above the preset voltage value.

The dead line detection function is described in a separate document.

4.2.8.1.2. “Voltage transformer supervision” (VTS) function - modes of operation

The voltage transformer supervision function can be used in three different modes of application:

Zero sequence detection (for typical applications in systems with grounded neutral): “VT failure” signal is generated if the residual voltage ($3U_0$) is above the preset voltage value AND the residual current ($3I_0$) is below the preset current value.

Negative sequence detection (for typical applications in systems with isolated or resonant grounded (Petersen) neutral): “VT failure” signal is generated if the negative sequence voltage component (U_2) is above the preset voltage value AND the negative sequence current component (I_2) is below the preset current value.

Special application: “VT failure” signal is generated if the residual voltage ($3U_0$) is above the preset voltage value AND the residual current ($3I_0$) AND the negative sequence current component (I_2) are below the preset current values.



4.2.8.1.3. Activating the VTS function

The voltage transformer supervision function can be activated if “Live line” status is detected for at least 200 ms. This delay avoids mal-operation at line energizing if the poles of the circuit breaker make contact with a time delay. The function is set to be inactive if “Dead line” status is detected.

If the conditions specified by the selected mode of operation are fulfilled (for at least 4 milliseconds) then the voltage transformer supervision function is activated and the operation signal is generated. (When evaluating this time delay, the natural operating time of the applied Fourier algorithm must also be considered.)

NOTE: For the operation of the voltage transformer supervision function the “Dead line detection function” must be operable as well: it must be enabled by binary parameter setting, and its blocking signal may not be active.

4.2.8.1.4. Resetting the VTS function

If, in the active state, the conditions for operation are no longer fulfilled, the resetting of the function depends on the mode of operation of the primary circuit:

- If the “Live line” state is valid, then the function resets after approx. 200 ms of time delay. (When evaluating this time delay, the natural operating time of the applied Fourier algorithm must also be considered.)
- If the “Dead line” state is started and the “VTS Failure” signal has been continuous for at least 100 ms, then the “VTS failure” signal does not reset; it is generated continuously even when the line is in a disconnected state. Thus, the “VTS Failure” signal remains active at reclosing.
- If the “Dead line” state is started and the “VTS Failure” signal has not been continuous for at least 100 ms, then the “VTS failure” signal resets.

4.2.8.2. Structure of the voltage transformer supervision algorithm

Fig.1-1 shows the structure of the voltage transformer supervision (VTS) algorithm.

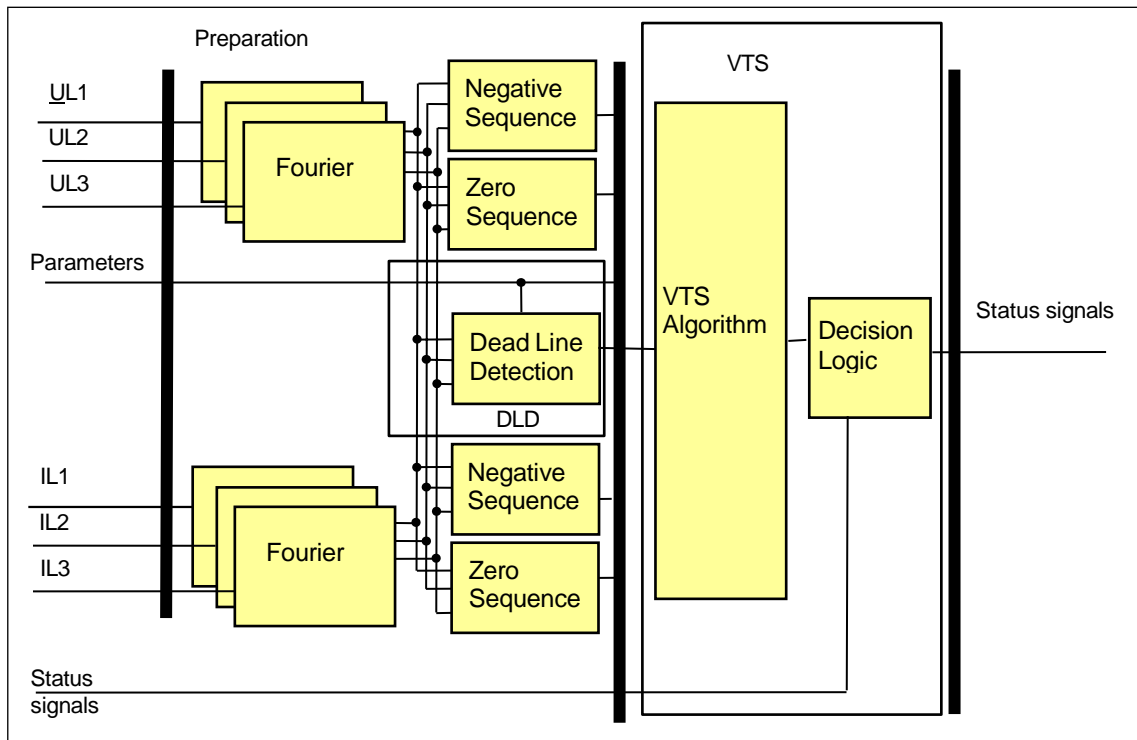

Figure 1-1 Structure of the voltage transformer supervision algorithm

For the preparation phase:

The **inputs** are

- the sampled values of the three phase voltages (UL1, UL2, UL3) and three phase currents (IL1, IL2, IL3),
- parameters.

The **outputs** are

- negative and zero sequence voltage and current components.
- signals indicating the “Live line” or “Dead line” condition.

For the VTS function:

The **inputs** are

- negative and zero sequence voltage and current components.
- signals indicating the “Live line” or “Dead line” condition,
- parameters,
- status signals.

The **outputs** are

- the binary output status signal indicating a failure of the voltage transformer secondary circuit,
- signals indicating the “Live line” or “Dead line” condition.



The **software modules** of the voltage transformer supervision function and those of the preparation phase:

Fourier calculations

These modules calculate the basic Fourier current components of the phase voltages and currents. These modules belong to the preparation phase.

Negative sequence

This module calculates the basic Fourier current components of the negative sequence voltage and current, based on the Fourier components of the phase voltages and currents. This module belongs to the preparation phase.

Zero sequence

This module calculates the basic Fourier voltage and current components of the residual voltage ($3U_0$) and current ($3I_0$), based on the Fourier components of the phase voltages and currents. This module belongs to the preparation phase.

Dead Line Detection

This module decides if the “Line_OK condition” or the “DeadLine condition” is fulfilled. This module belongs to the preparation phase.

VTS algorithm

This module decides if the “VTS_FAIL” conditions are fulfilled according to the conditions specified for the selected mode.

Decision logic

The decision logic module combines the status signals to generate the trip command of the function.

The following description explains the details of the individual components.

4.2.8.3. The Fourier calculation (Fourier)

These modules calculate the basic Fourier current components of the phase voltages and phase currents individually. These modules belong to the preparation phase.

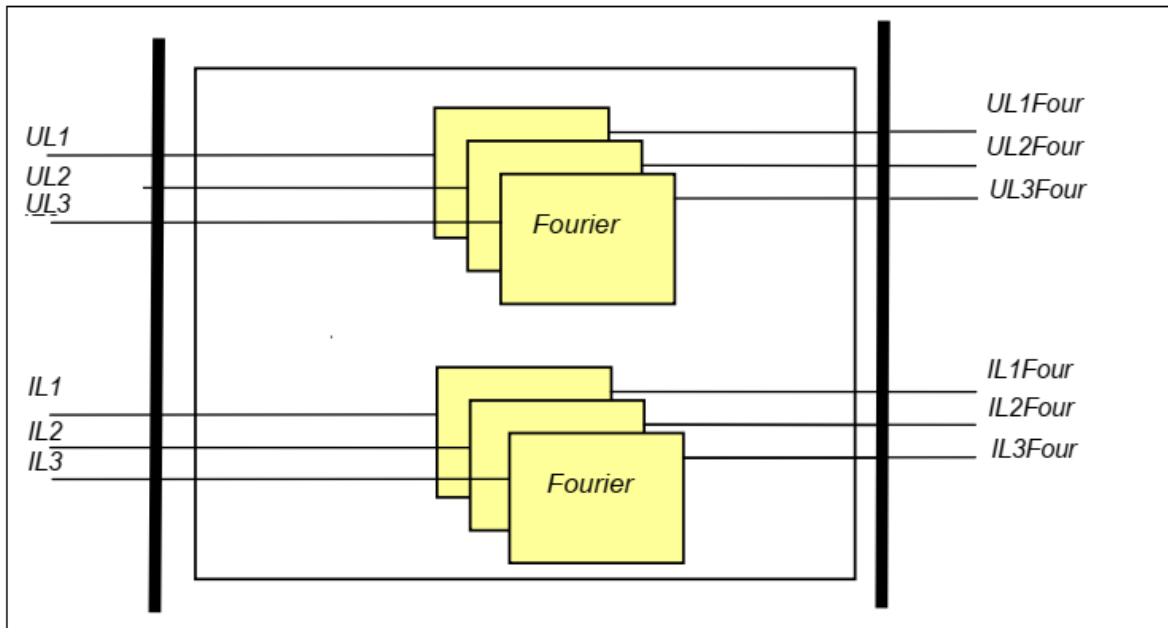

Figure 1-2 Principal scheme of the Fourier calculation

The **inputs** are the sampled values of:

- the three phase voltages (UL1, UL2, UL3)
- the three phase currents (IL1, IL2, IL3)

The **outputs** are

- the basic Fourier components of the analyzed voltages (UL1Four, UL2Four, UL3Four),
- the basic Fourier components of the analyzed currents (IL1Four, IL2Four, IL3Four).

4.2.8.4. The negative phase sequenc calculation (Negative sequence)

This module calculates the negative phase sequence components based on the Fourier components of the phase voltages and phase currents. These modules belong to the preparation phase.

The **inputs** are the basic Fourier components of the phase voltages and phase currents (UL1Four, UL2Four, UL3Four, IL1Four, IL2Four, IL3Four).

The **outputs** are

- the basic Fourier components of the negative sequence voltage component (UNegFour),
- the basic Fourier components of the negative sequence current component (INegFour).

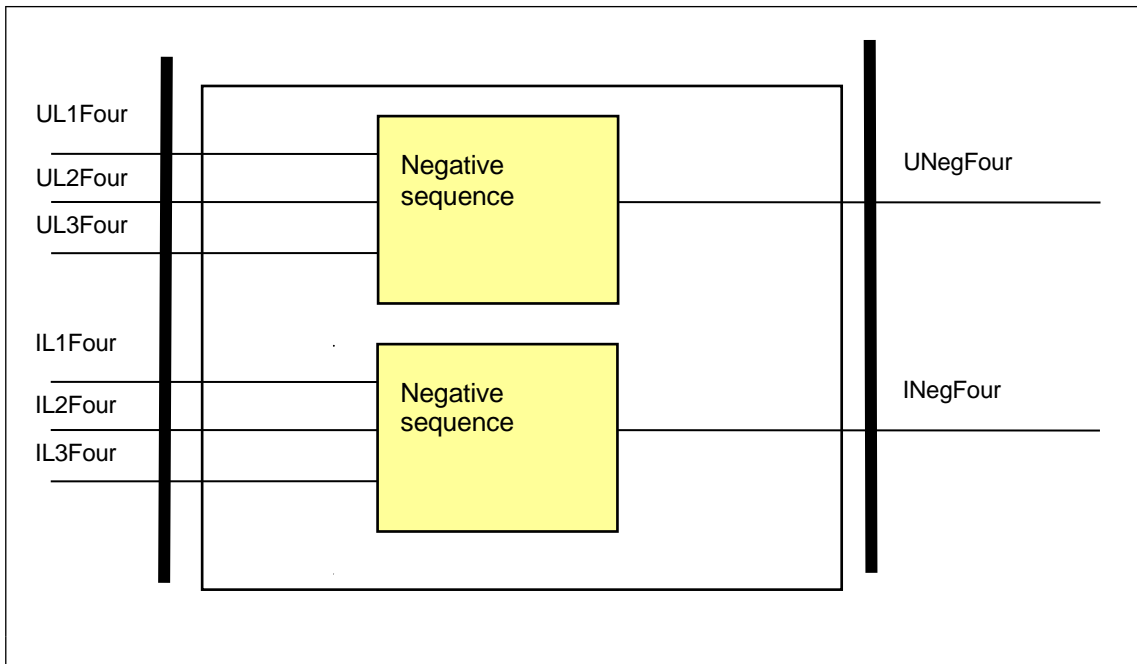

Figure 1-3 Schema of the negative sequence component calculation

4.2.8.5. The residual voltage and current calculation (Zero sequence)

This module calculates the residual voltage ($U_{ZerFour}$) and current ($I_{ZerFour}$) based on the Fourier components of the phase voltages and currents. These modules belong to the preparation phase.

The **inputs** are

- the basic Fourier components of the phase voltages ($UL1Four$, $UL2Four$, $UL3Four$),
- the basic Fourier components of the phase currents ($IL1Four$, $IL2Four$, $IL3Four$).

The **outputs** are

- the basic Fourier components of the residual voltage ($U_{ZerFour}$),
- the basic Fourier components of the residual current ($I_{ZerFour}$).

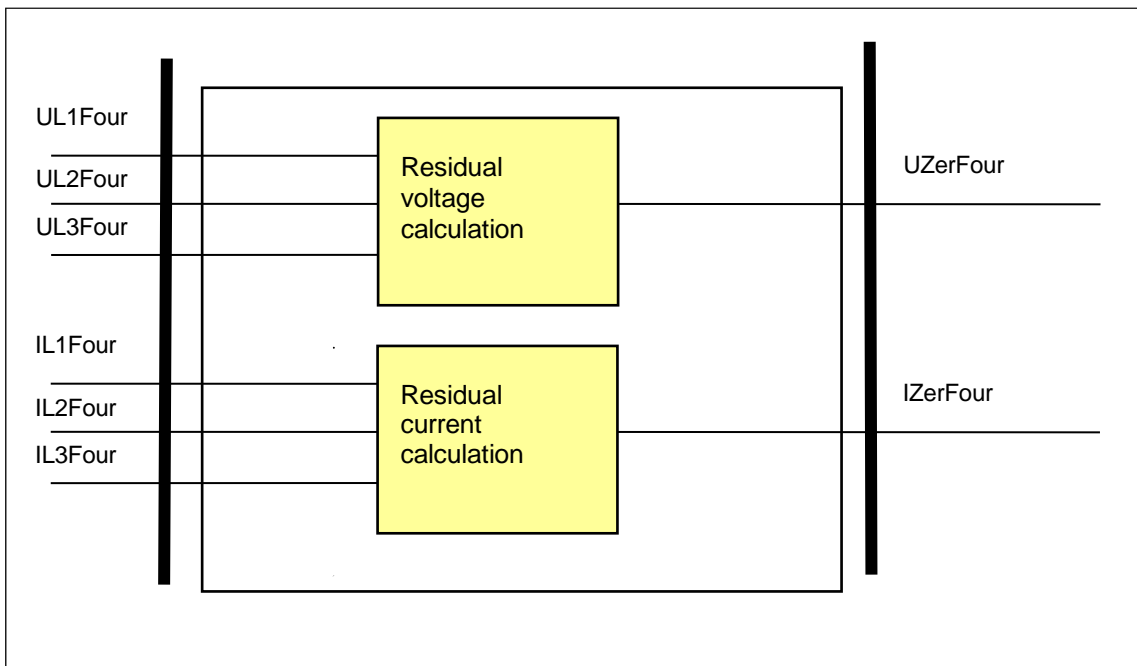

Figure 1-4 Schema of the residual voltage and current calculation

4.2.8.6. The dead line detection algorithm (Dead Line Detection)

This module decides if the “Line_OK condition” or the “DeadLine condition” is fulfilled. This module belongs to the preparation phase.

The **inputs** are

- the basic Fourier components of the phase voltages (UL1Four, UL2Four, UL3Four),
- the basic Fourier components of the phase currents (IL1Four, IL2Four, IL3Four),
- parameters.

The **outputs** are the internal status signals of the function. These indicate the “DeadLine condition state” or the “Line_OK conditions” state. This module belongs to the preparation phase.

Criteria of “Dead line” state: all three phase voltages are below the voltage setting value AND all three currents are below the current setting value.

Criteria of “Live line” state: all three phase voltages are above the voltage setting value.

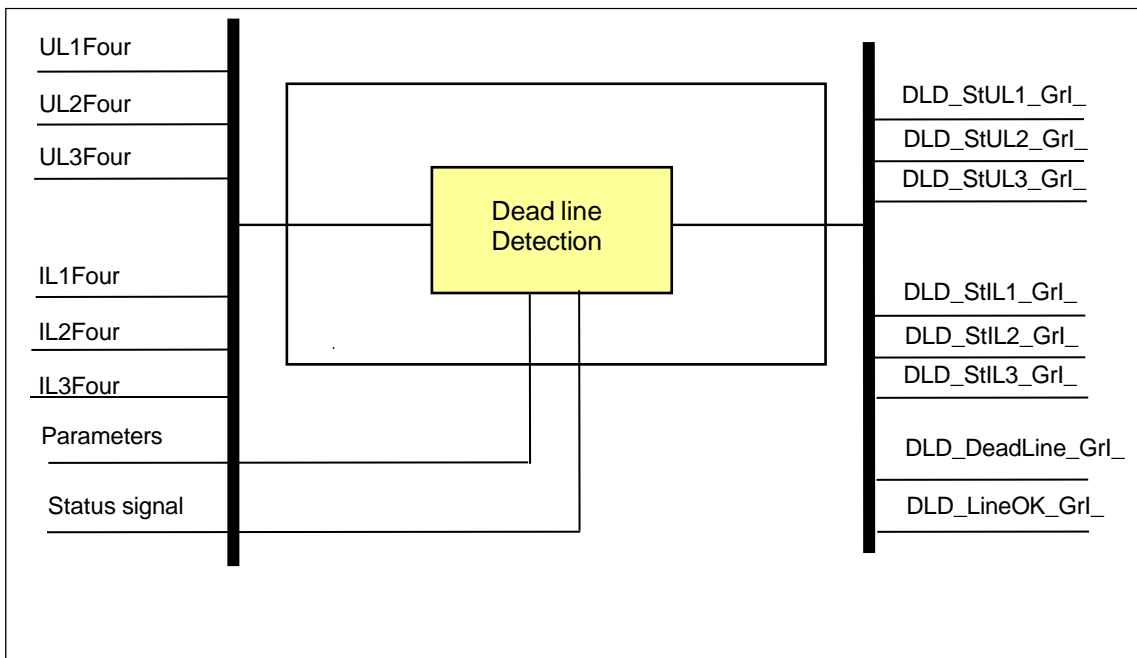

Figure 1-5 Principal scheme of the dead line detection function

The parameters of the dead line detection function are listed in Table 1-1.

Integer parameters

Parameter name	Title	Unit	Min	Max	Step	Default
Integer parameters of the dead line detection function						
DLD_ULev_IPar_	Min Operate Voltage	%	10	100	1	60
DLD_ILev_IPar_	Min Operate Current	%	2	100	1	10

Table 1-1 The integer parameters of the dead line detection function

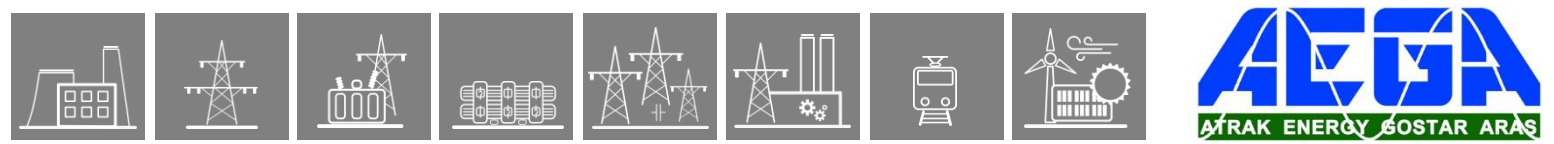

Binary status signals

The dead line detection function has a binary input signal, which serves the purpose of disabling the function. **The conditions of disabling are defined by the user, applying the graphic equation editor.**

Binary status signal	Explanation
DLD_Blk_GrO_	Output status of a graphic equation defined by the user to disable the dead line detection function.

Table 1-2 The binary input signal of the dead line detection function

The **binary output status signals** of the dead line detection function are listed in Table 1-3.

Binary output signals	Signal title	Explanation
DLD_StUL1_GrI_	Start UL1	The voltage of phase L1 is above the preset parameter value
DLD_StUL2_GrI_	Start UL2	The voltage of phase L2 is above the preset parameter value
DLD_StUL3_GrI_	Start UL3	The voltage of phase L3 is above the preset parameter value
DLD_StIL1_GrI_	Start IL1	The current of phase L1 is above the preset parameter value
DLD_StIL2_GrI_	Start IL2	The current of phase L2 is above the preset parameter value
DLD_StIL3_GrI_	Start IL3	The current of phase L3 is above the preset parameter value
DLD_DeadLine_GrI_	DeadLine condition	The criteria for dead line condition are fulfilled
DLD_LineOK_GrI_	LineOK condition	The criteria for line OK condition are fulfilled

Table 1-3 The binary output status signals of the dead line detection function



4.2.8.7. Voltage transformer supervision (VTS algorithm)

The voltage transformer supervision function can be used in three different modes of operation:

Zero sequence detection (for typical applications in systems with grounded neutral): “VT failure” signal is generated if the residual voltage ($3U_0$) is above the preset voltage value AND the residual current ($3I_0$) is below the preset current value.

Negative sequence detection (for typical applications in systems with isolated or resonant grounded (Petersen) neutral): “VT failure” signal is generated if the negative sequence voltage component (U_2) is above the preset voltage value AND the negative sequence current component (I_2) is below the preset current value.

Special application: “VT failure” signal is generated if the residual voltage ($3U_0$) is above the preset voltage value AND the residual current ($3I_0$) AND the negative sequence current component (I_2) are below the preset current values.

The task of this module is to detect if the conditions of the “VTS FAIL” state are fulfilled, according to the conditions defined for the selected mode of operation.

The **inputs** are

- the basic Fourier components of the residual voltage ($UZerFour$) and current ($IZerFour$),
- the negative sequence components of the voltage ($UNegFour$) and current ($INegFour$),
- binary signals from the dead line detection function,
- parameters.

NOTE: For the operation of the voltage transformer supervision function the “Dead line detection function” must be operable as well: it must be enabled by binary parameter setting, and its blocking signal may not be active.

The **output** is the internal status signal of the function. This internal signal indicates if the “VTS_FAIL_int” condition is fulfilled.

Binary output signals	Signal title	Explanation
VTS_FAIL_int	VTS_FAIL_int	Internal status signal indicating the fulfillment of conditions. This status signal is not available for the users.

Table 1-4 The binary internal status signals of the voltage transformer supervision algorithm

The parameters of the voltage transformer supervision algorithm are listed in [Table 1-5](#) and in [Table 1-6](#).

4.2.8.8. The decision logic (Decision logic)

The decision logic module combines the status signals, binary and enumerated parameters to generate the trip command of the function.

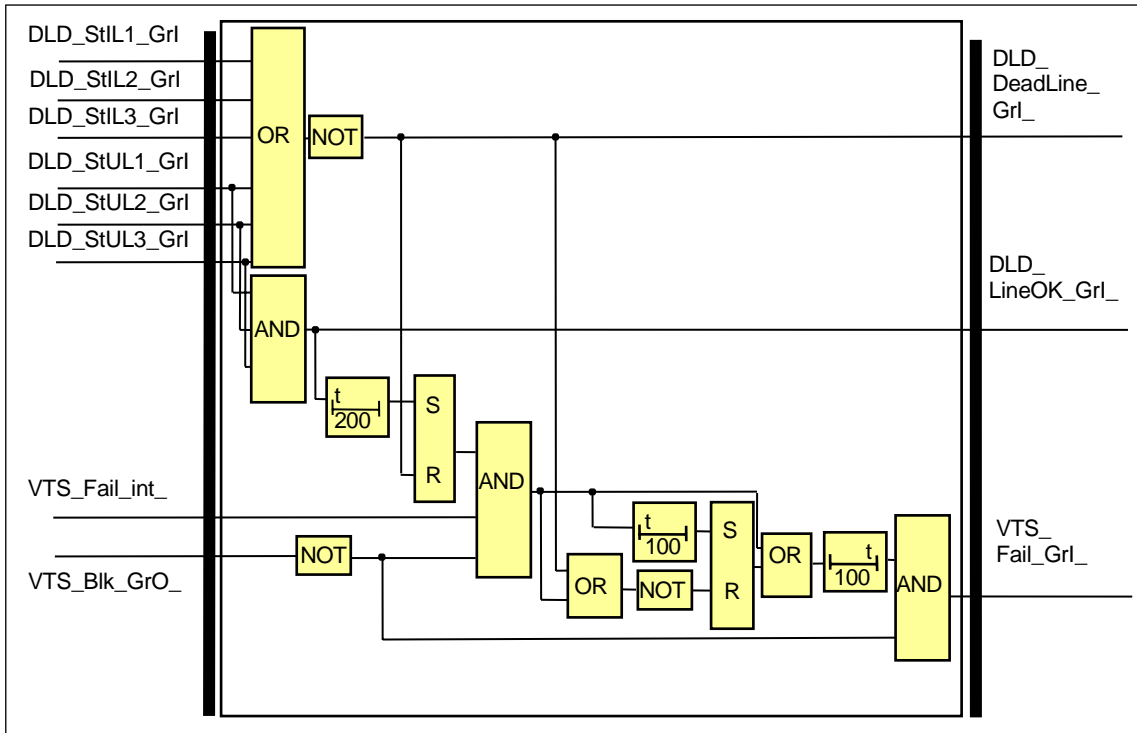

Figure 1-6 The logic scheme of the decision logic

Binary input signals	Signal title	Explanation
DLD_StUL1_Grl_	Start UL1	The voltage of phase L1 is above the preset parameter value
DLD_StUL2_Grl_	Start UL2	The voltage of phase L2 is above the preset parameter value
DLD_StUL3_Grl_	Start UL3	The voltage of phase L3 is above the preset parameter value
DLD_StIL1_Grl_	Start IL1	The current of phase L1 is above the preset parameter value
DLD_StIL2_Grl_	Start IL2	The current of phase L2 is above the preset parameter value
DLD_StIL3_Grl_	Start IL3	The current of phase L3 is above the preset parameter value
VTS_FAIL_int	VTS_FAIL_int	Internal status signal indicating the fulfillment of conditions. This status signal is not available for the users.

Table 1-7 The binary input signals of the decision logic

Binary status signals

The voltage transformer supervision function has a binary input signal, which serves the purpose of disabling the function. **The conditions of disabling are defined by the user, applying the graphic equation editor.**

Binary status signal	Explanation
VTS_BlK_GrO_	Output status of a graphic equation defined by the user to disable the voltage transformer supervision function.

Table 1-8 The binary input signal of the decision logic

Binary output signals	Signal title	Explanation
DLD_DeadLine_GrI_	DeadLine condition	The requirements of “DeadLine condition” are fulfilled
DLD_LineOK_GrI_	LineOK condition	The requirements of “LineOK condition” are fulfilled
VTS_Fail_GrI	VT Failure	Failure status signal of the VTS function

Table 1-9 The binary output status signals of the decision logic

4.2.8.9. Technical summary

4.2.8.9.1. Technical data

Function	Value	Accuracy
Pick-up voltage I ₀ =0A I ₂ =0A		<1% <1%
Operation time	<20ms	
Reset ratio	0.95	

Table 1-10 Technical data of the voltage transformer supervision function

4.2.8.9.2. The parameters

Integer parameters

Parameter name	Title	Unit	Min	Max	Step	Default
Integer parameters of the dead line detection function						
DLD_ULev_IPar_	Min Operate Voltage	%	10	100	1	60
DLD_ILev_IPar_	Min Operate Current	%	2	100	1	10
Starting voltage and current parameter for residual and negative sequence detection:						
VTS_Uo_IPar_	Start URes	%	5	50	1	30
VTS_Io_IPar_	Start IRes	%	10	50	1	10
VTS_Uneg_IPar_	Start UNeg	%	5	50	1	10
VTS_Ineg_IPar_	Start INeg	%	10	50	1	10

Table 1-11 The integer parameters of the voltage transformer supervision function

Enumerated parameter

Parameter name	Title	Selection range	Default
Parameter for type selection			
VTS_Oper_EPar_	Operation	Off, Zero sequence, Neg. sequence, Special	Zero sequence

Table 1-12 The enumerated parameter of the voltage transformer supervision function

4.2.8.9.3. The binary input status signals

Binary status signals

The voltage transformer supervision function has a binary input signal, which serves the purpose of disabling the function. **The conditions of disabling are defined by the user, applying the graphic equation editor.**

Binary status signal	Explanation
VTS_BlK_GrO_	Output status of a graphic equation defined by the user to disable the voltage transformer supervision function.

Table 1-13 The binary input signal of the voltage transformer supervision function

4.2.8.9.4. Binary output status signals

The **binary output status signals** of the voltage transformer supervision function are listed in Table 1-14.

Binary output signals	Signal title	Explanation
DLD function		
DLD_StUL1_Grl_	Start UL1	The voltage of phase L1 is above the preset parameter value, signal of the DLD function
DLD_StUL2_Grl_	Start UL2	The voltage of phase L2 is above the preset parameter value, signal of the DLD function
DLD_StUL3_Grl_	Start UL3	The voltage of phase L3 is above the preset parameter value, signal of the DLD function
DLD_StIL1_Grl_	Start IL1	The current of phase L1 is above the preset parameter value, signal of the DLD function
DLD_StIL2_Grl_	Start IL2	The current of phase L2 is above the preset parameter value, signal of the DLD function
DLD_StIL3_Grl_	Start IL3	The current of phase L3 is above the preset parameter value, signal of the DLD function
DLD_DeadLine_Grl_	DeadLine condition	The requirements of "DeadLine condition" are fulfilled, signal of the DLD function
DLD_LineOK_Grl_	LineOK condition	The requirements of "LineOK condition" are fulfilled, signal of the DLD function
VTS function		
VTS_Fail_Grl	VT Failure	Failure status signal of the VTS function

Table 1-14 The binary output signals of the voltage transformer supervision function

4.2.8.9.5. The function block

The function block of the dead line detection and voltage transformer supervision function is shown in Figure 1-7. This block shows all binary input and output status signals that are applicable in the graphic equation editor.

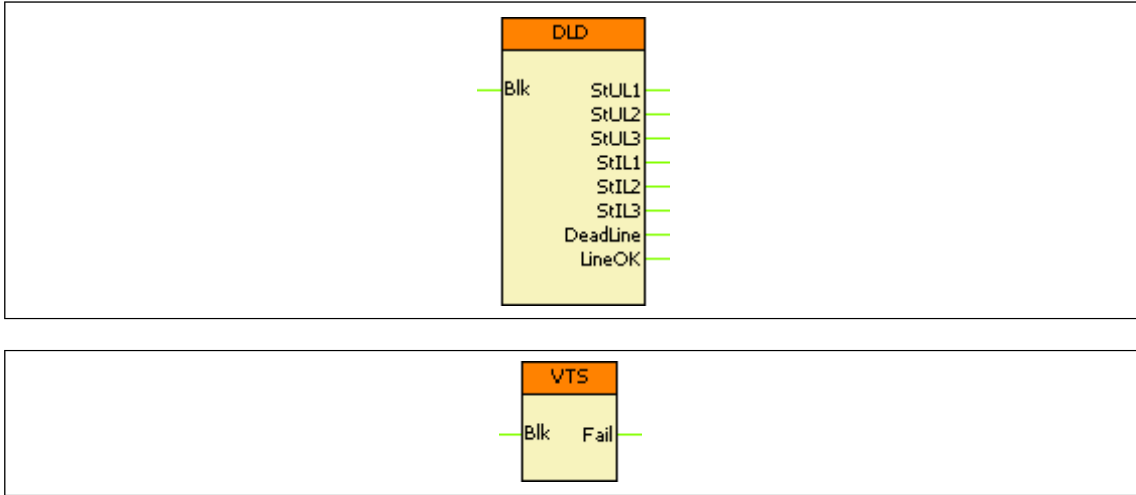

Figure 1-7 The function block of the dead line detection and voltage transformer supervision function

4.2.9. Current unbalance function

4.2.9.1. Application

The current unbalance protection function can be applied to detect unexpected asymmetry in current measurement.

4.2.9.1.1. Mode of operation

The applied method selects maximum and minimum phase currents (RMS values of the fundamental Fourier components). If the difference between them is above the setting limit, the function generates a start signal. It is a necessary precondition of start signal generation that the maximum of the currents be above 10 % of the rated current and below 150% of the rated current.

The function can be disabled by parameter setting, and by an input signal programmed by the user with the graphic programming tool.

The trip command is generated after the defined time delay if trip command is enabled by parameter setting.

4.2.9.1.2. Operation principles

Figure 1-1 shows the structure of the current unbalance protection algorithm.

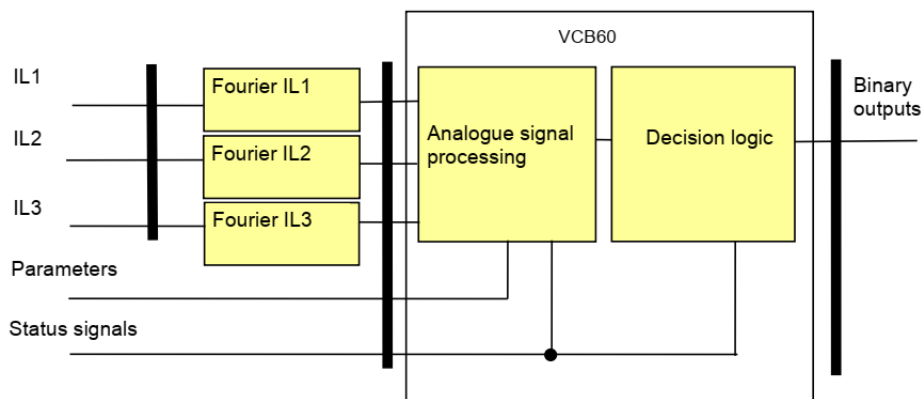

Figure 1-1 Structure of the current unbalance protection algorithm

The **inputs** of the preparatory phase are

- the three phase currents,

The **outputs** of the preparatory phase are

- the RMS values of the fundamental Fourier component of three phase currents.

The **inputs** of the current unbalance function are

- the RMS values of the fundamental Fourier component of three phase currents,
- parameters,
- status signals.

The **outputs** are

- the binary output status signals.

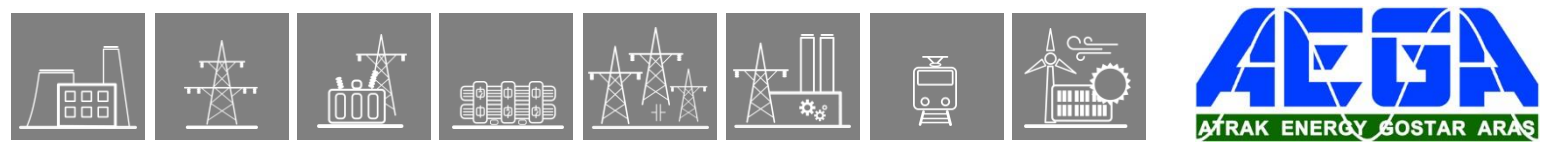

The **software modules** of the current unbalance function:

Fourier calculations

These modules calculate the RMS values of the basic Fourier current components of the phase currents individually (not part of the VCB60 function).

Analogue signal processing

This module processes the RMS values of the Fourier components of the phase currents to prepare the signals for the decision.

Decision logic

The decision logic module combines the status signals to generate the starting signal and the trip command of the function.

The following description explains the details of the individual components.

4.2.9.1.3. The Fourier calculation (Fourier)

These modules calculate the RMS values of the fundamental Fourier components of the phase currents individually. They are not part of the VCB60 function; they belong to the preparatory phase.

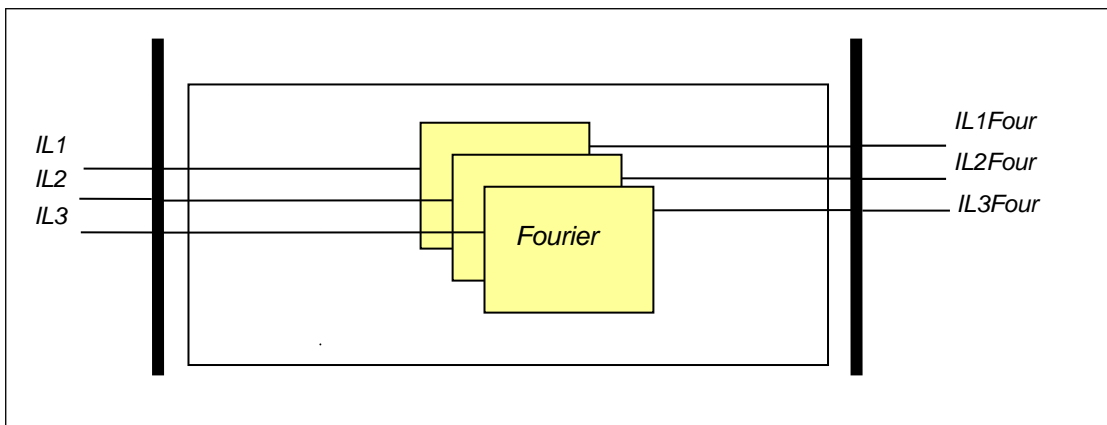

Figure 1-2 Principal scheme of the Fourier calculation

The **inputs** are the sampled values of the three phase currents (IL1, IL2, IL3)

The **outputs** are the RMS values of the fundamental Fourier components of the phase currents (IL1Four, IL2Four, IL3Four).

4.2.9.1.4. The Analogue signal processing

This module processes the Fourier components of the phase currents to prepare the signals for the decision.

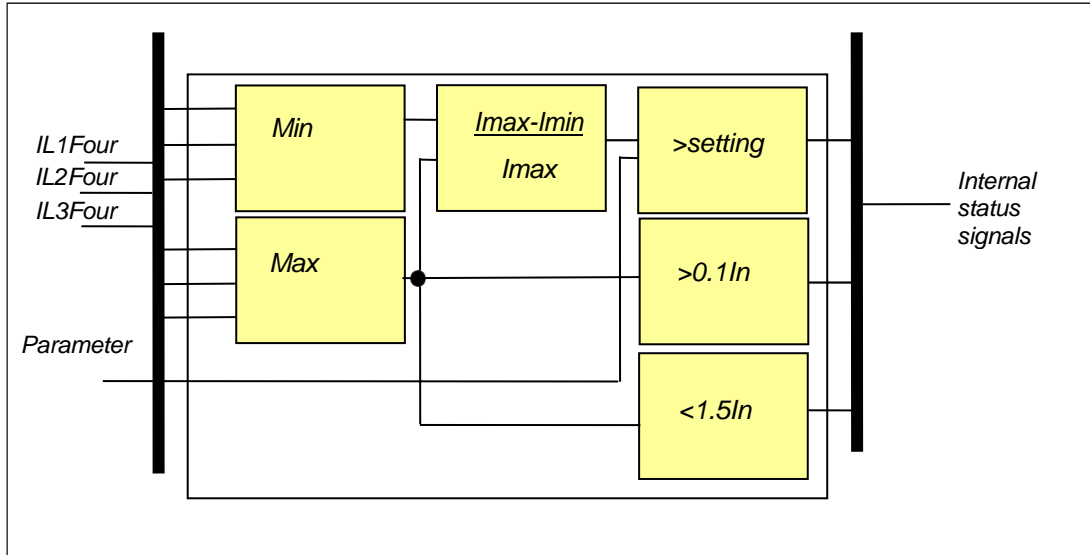

Figure 1-3 Principal scheme of the analogue signal processing

The **inputs** are the fundamental Fourier components of the analyzed currents (IL1Four, IL2Four, IL3Four)

The **outputs** are internal binary signals:

- $\Delta I >$ The difference between the maximum and minimum of the RMS values of the fundamental Fourier components of the phase currents as a percentage of the maximum of these values is above the limit defined by the preset parameter "Start current";
- $I_{max} > 0.1 I_n$ The maximum of the RMS values of the fundamental Fourier components of the phase currents is sufficient for evaluation;
- $I_{max} < 1.5 I_n$ The maximum of the RMS values of the fundamental Fourier components of the phase currents is not considered as a fault current.

4.2.9.1.5. The decision logic (Decision logic)

The decision logic module combines the status signals, binary and enumerated parameters to generate the trip command of the function.

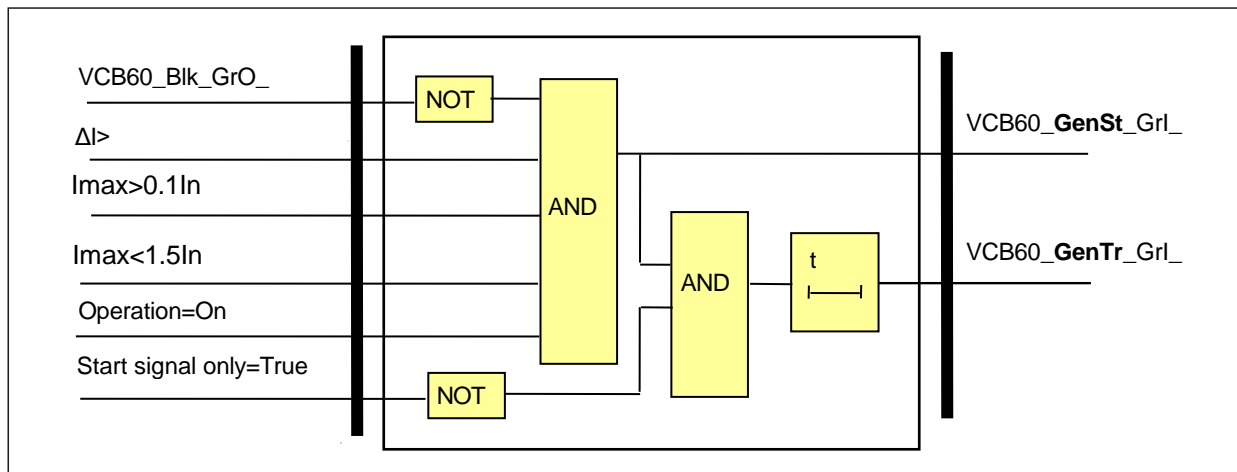

Figure 1-4 The logic scheme of the current unbalance function

The **inputs** are internal binary signals:

- $\Delta I >$ the difference between the maximum and minimum of the RMS values of the fundamental Fourier components of the phase currents as a percentage of the maximum of these values is above the limit defined by parameter setting "Start Current Diff";
- $I_{max} > 0.1 I_n$ the maximum of the RMS values of the fundamental Fourier components of the phase currents is sufficient for evaluation;
- $I_{max} < 1.5 I_n$ the maximum of the RMS values of the fundamental Fourier components of the phase currents is not considered as a fault current.

4.2.9.2. Current unbalance protection function overview

The graphic appearance of the function block of the current unbalance protection function is shown below. The block shows all binary input and output status signals which are applicable in the graphic equation editor.

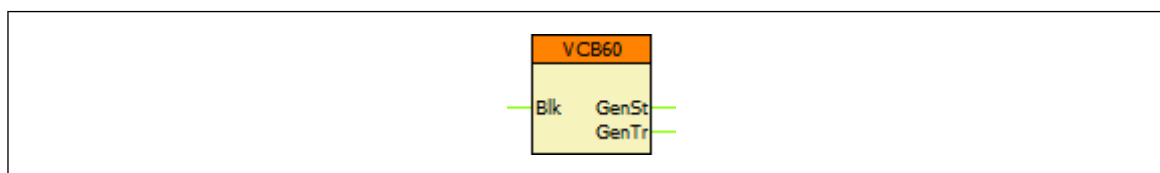

Figure 2-1 Graphic appearance of the function block of the current unbalance protection function

4.2.9.2.1. Settings

4.2.9.2.1.1. Parameters

The available parameters are listed below in order of their appearance in the *parameters* menu. If the setting range of a parameter should be extended, contact Protecta Support.

Table 2-1 Parameters of the current unbalance protection function

TITLE	DIM	RANGE	STEP	DEFAULT	EXPLANATION
Operation	-	Off, On	-	Off	Enabling the function
Start Signal Only	-	FALSE, TRUE	-	FALSE	When checked, the function provides start signal only, and no trip signal.
Start Current	%	10 – 90	1	50	Phase difference current setting
Time Delay	msec	100 – 60000	1	1000	Time delay (including the algorithm time, see Chapter 2.4 for more explanation)

4.2.9.2.2. Function I/O

This section describes briefly the analogue and digital inputs and outputs of the function block.

4.2.9.2.2.1. Analogue inputs

The function uses the sampled values of a current input. This is defined in the configuration.

4.2.9.2.2.2. Binary input signals (graphed output statuses)

The conditions of the binary inputs are defined by the user, applying the graphic equation editor (*Logic Editor*). Parts written in **bold** are seen on the left side function block in the Logic editor.

Table 2-2 The binary input signal of the current unbalance protection function

BINARY OUTPUT SIGNAL	EXPLANATION
VCB60_ Blk _GrO_	Blocking input of the function

4.2.9.2.2.3. Binary output signals (graphed input statuses)

These signals can be used in EuroCAP to assign to LED, user LCD object etc. Parts written in **bold** are seen on the right side of the function block in the *Logic Editor*.

Table 2-3 The binary output signals of the current unbalance protection function

BINARY OUTPUT SIGNAL	SIGNAL TITLE	EXPLANATION
VCB60_ GenSt _Grl_	General Start	General start signal of the function
VCB60_ GenTr _Grl_	General Trip	General trip command of the function

4.2.9.2.2.4. Online data

Visible values on the *online data* page.

Table 2-4 Online displayed data of the current unbalance protection function

SIGNAL TITLE	DIMENSION	EXPLANATION
General Start	-	General start signal of the function
General Trip	-	General trip command of the function

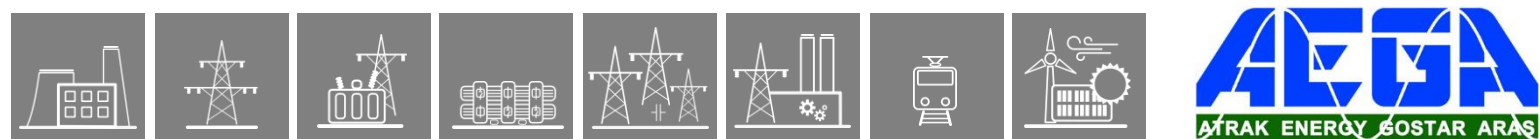

4.2.9.2.2.5. Events

The following events are generated in the event list, as well as sent to the SCADA according to the configuration.

Table 2-5 Generated events of the current unbalance protection function

EVENT	VALUE	EXPLANATION
General Start	off, on	General start of the function
General Trip	off, on	General trip command of the function

4.2.9.2.3. Technical data

Table 2-6 Technical data of the current unbalance protection function

FUNCTION	VALUE	ACCURACY
Pick-up starting accuracy at In		< 2 %
Reset ratio	0,95	
Operate time	70 ms	

4.2.9.2.4. Notes for testing

Normally in the EuroProt+ devices the trip contacts are assigned to the Trip Logic function block, and not to the protection function blocks. Because of this, the testing personnel must make sure that the Trip Logic is switched on ('Operation' parameter is set to other than 'Off') before starting the tests, otherwise there will be no physical trip on the relay.

Note that the time delay parameter incorporates the algorithm time as well, so the time delay *does not mean the time difference between the appearance of the start and trip signals* of the function. In other words: it is not the delay between the detection of the fault and the trip that follows it. This should be taken into consideration when checking the disturbance records.

Instead the time delay parameter defines the elapsed time from the appearance of the faulty state to the trip. Because of this, while testing, the delay measurement should start *from the moment of the fault injection* until the trip signal.

4.2.10. Earth-fault phase selection function

The protection functions, based on residual current and/or voltage measurement can detect the earth-fault on the network, they can however not select the faulty phase. The simple function, described in this document measures the three phase voltages. After starting by any kind of residual protection functions, this software module evaluates the phase voltages. The one below the threshold level indicates the faulty phase.

4.2.10.1. Operation of the earth-fault phase selection function

The operation of the function is started by any kind of residual protection functions. Usually the trip command, generated by this functions is configured to the start input (EF_Trip). If it is not configured in the factory, the user can define it or can edit it, using the graphic logic editor.

The operation of the function can be blocked by an active signal connected to the dedicated binary input (VTS). Usually the error signal of the voltage transformer supervision function is assigned to this input. If it is not configured in the factory, the user can define it, using the graphic logic editor.

The function gets the calculated Fourier basic harmonics of the three phase voltages (UL1Four, UL2Four, UL3Four). The Fourier calculation is not part of this function, it belongs to the preparatory phase, and these calculated values may be applied by other functions configured in the device.

There are three embedded, simplified undervoltage functions (TUV27 L1, TUV27 L2 and TUV27 L3), which compare the Fourier magnitude values with the voltage parameter (Start Voltage). If any of the voltages is below this threshold value, the phase-selective outputs indicate the faulty phase.

4.2.10.2. Structure of the earth-fault phase selection algorithm

Figure 1-1 shows the structure of the phase selection algorithm.

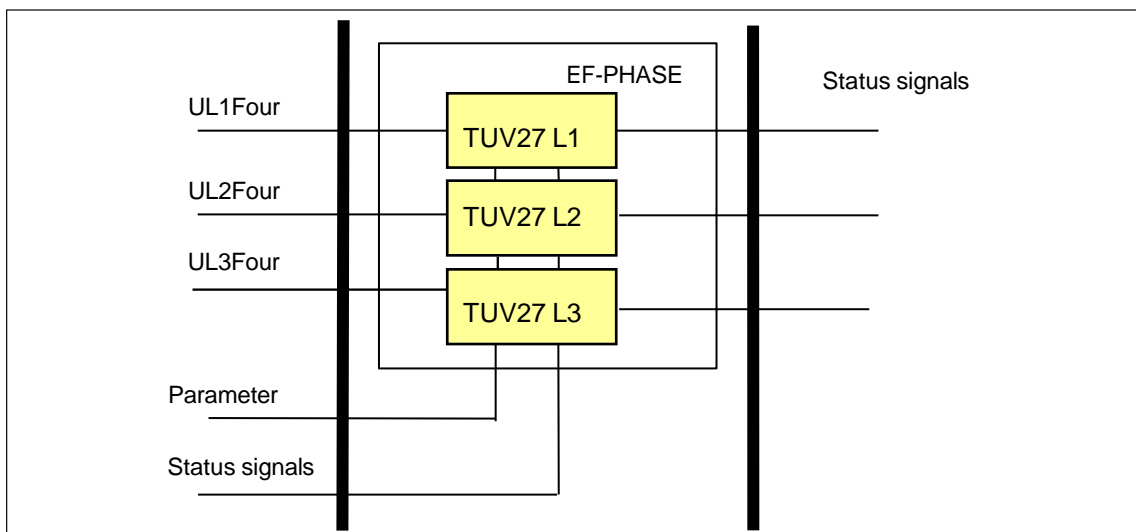
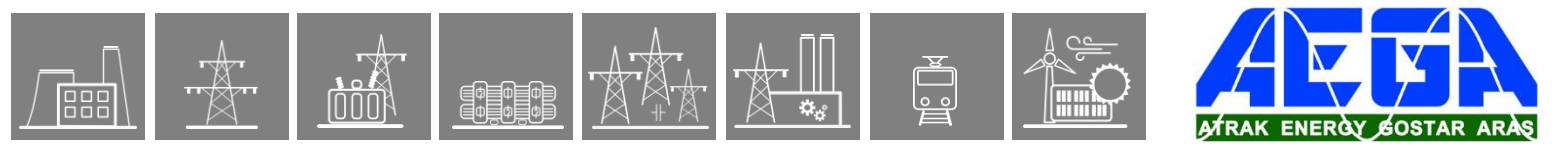

Figure 1-1 Structure of the earth-fault phase selection algorithm



The **inputs** are

- the RMS value of the fundamental Fourier component of the phase voltages,
- parameters,
- status signals.

The **outputs** are

- the binary output status signals.

4.2.10.3. Parameter of the earth-fault phase selection function

The function has a single parameter to define the starting voltage in %, below which the phase is evaluated as the faulty phase.

Integer parameter

Parameter name	Title	Unit	Min	Max	Step	Default
Starting voltage parameter:						
TUV27_StVol_IPar_	Start Voltage	%	5	57	1	45

Table 1-1 The integer parameters of the earth-fault phase selection function

Note: the function is a simplified undervoltage function. All other parameters are hidden, the user cannot modify the values of these parameters.

4.2.10.4. Output status signals of the earth-fault phase selection function

The **binary output status signals** of the earth-fault phase selection function are listed in Table 1-2.

Binary output signals	Signal title	Explanation
TUV27_StL1_Grl_	Start L1	Starting of the function in phase L1
TUV27_StL2_Grl_	Start L2	Starting of the function in phase L2
TUV27_StL3_Grl_	Start L3	Starting of the function in phase L3

Table 1-2 The binary output status signals of the earth-fault phase selection function

4.2.10.5. Input status signals of the earth-fault phase selection function

Binary input signal

The residual overcurrent protection function has a binary input signal, which serves the purpose of disabling the function. **The conditions of disabling are defined by the user, applying the graphic equation editor.**

Binary output signals	Signal title	Explanation
TUV27_EFTrip_GrO_	EFTrip	Starting of the function, usually by the TRIP command of residual functions
TUV27_VTS_GrO_	VTS	Blocking by voltage transformer supervision

Table 1-3 The binary input signal of the earth-fault phase selection function

4.2.10.6. The function block of the earth-fault phase selection function

The function block of the earth-fault phase selection function is shown in Figure 1-2. This block shows all binary input and output status signals that are applicable in the graphic logic editor.

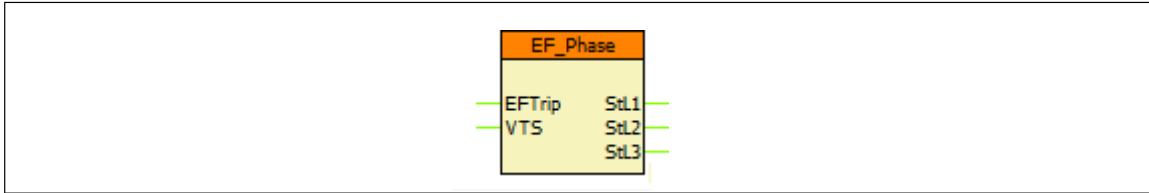

Figure 1-2 The function block of the earth-fault phase selection function

4.2.10.7. Technical data

Function	Value	Accuracy
Pick-up starting accuracy		< ± 0,5 %
Blocking voltage	0	
Reset ratio	1.05	
Reset time		
U> → Un	50 ms	
U> → 0	40 ms	
Operate time accuracy	100 ms	< ± 20 ms

Table 1-4 Technical data of the undervoltage protection function

4.3. Measuring functions

The measured values can be checked on the touch-screen of the device in the “On-line functions” page, or using an Internet browser of a connected computer. The displayed values are secondary voltages and currents, except the block “Line measurement”. This specific block displays the measured values in primary units, using VT and CT primary value settings.

Analog value	Explanation
VT4 module	
Voltage Ch – U1	RMS value of the Fourier fundamental harmonic voltage component in phase L1
Angle Ch – U1	Phase angle of the Fourier fundamental harmonic voltage component in phase L1*
Voltage Ch – U2	RMS value of the Fourier fundamental harmonic voltage component in phase L2
Angle Ch – U2	Phase angle of the Fourier fundamental harmonic voltage component in phase L2*
Voltage Ch – U3	RMS value of the Fourier fundamental harmonic voltage component in phase L3
Angle Ch – U3	Phase angle of the Fourier fundamental harmonic voltage component in phase L3*
Voltage Ch – U4	RMS value of the Fourier fundamental harmonic voltage component in Channel U4
Angle Ch – U4	Phase angle of the Fourier fundamental harmonic voltage component in Channel U4*
CT4 module	
Current Ch - I1	RMS value of the Fourier fundamental harmonic current component in phase L1
Angle Ch - I1	Phase angle of the Fourier fundamental harmonic current component in phase L1*
Current Ch - I2	RMS value of the Fourier fundamental harmonic current component in phase L2
Angle Ch - I2	Phase angle of the Fourier fundamental harmonic current component in phase L2*
Current Ch - I3	RMS value of the Fourier fundamental harmonic current component in phase L3
Angle Ch - I3	Phase angle of the Fourier fundamental harmonic current component in phase L3*
Current Ch - I4	RMS value of the Fourier fundamental harmonic current component in Channel I4
Angle Ch - I4	Phase angle of the Fourier fundamental harmonic current component in Channel I4*
<i>Distance protection function (DIS21_HV)</i>	
Fault location	Measured distance to fault
Fault react.	Measured reactance in the fault loop
L1N loop R	Resistive component value of impedance in L1-N loop
L1N loop X	Reactive component value of impedance in L1-N loop
L2N loop R	Resistive component value of impedance in L2-N loop
L2N loop X	Reactive component value of impedance in L2-N loop
L3N loop R	Resistive component value of impedance in L3-N loop
L3N loop X	Reactive component value of impedance in L3-N loop
L12 loop R	Resistive component value of impedance in L12 loop
L12 loop X	Reactive component value of impedance in L12 loop
L23 loop R	Resistive component value of impedance in L23 loop
L23 loop X	Reactive component value of impedance in L23 loop
L31 loop R	Resistive component value of impedance in L31 loop
L31 loop X	Reactive component value of impedance in L31 loop

<i>Synchrocheck function (SYN25)</i>	
Voltage Diff	Voltage different value
Frequency Diff	Frequency different value
Angle Diff	Angle different value
<i>Line measurement (MXU_L) (here the displayed information means primary value)</i>	
Active Power – P	Three-phase active power
Reactive Power – Q	Three-phase reactive power
Apparent Power – S	Three-phase power based on true RMS voltage and current measurement
Current L1	True RMS value of the current in phase L1
Current L2	True RMS value of the current in phase L2
Current L3	True RMS value of the current in phase L3
Voltage L1	True RMS value of the voltage in phase L1
Voltage L2	True RMS value of the voltage in phase L2
Voltage L3	True RMS value of the voltage in phase L3
Voltage L12	True RMS value of the voltage between phases L1 L2
Voltage L23	True RMS value of the voltage between phases L2 L3
Voltage L31	True RMS value of the voltage between phases L3 L1
Frequency	Frequency
<i>Metering (MTR)</i>	
Forward MWh	Forward MWh
Backward MWh	Backward MWh
Forward MVarh	Forward MVarh
Backward MVarh	Backward MVarh
<i>Line thermal protection (TTR49L)</i>	
Calc. Temperature	Calculated line temperature

* *The reference angle is the phase angle of “Voltage Ch - U1”*

Table 3-146 Measured analog values

4.3.1. Current input function

4.3.1.1. Application of the current input function

The application of the current inputs depends on the correct connection of the hardware terminals and also on the correct parameter setting for the CT4 function block. This guide describes examples, based on which any other combinations can be realized.

In the applications of the current transformer hardware module, the first three current inputs (terminals 1-2, 3-4, 5-6) receive the three phase currents (IL1, IL2, IL3), the fourth input (terminals 7-8) is reserved for zero sequence current, for the zero sequence current of the parallel line or for any additional currents. Accordingly, the first three inputs have common parameters while the fourth current input needs individual setting.

The CT4 function block is an independent module in the sense that:

- It has independent parameters to be set, associated to the current inputs,
- It delivers the sampled current values for protection, measurement function blocks and for disturbance recording and for on-line displaying,
- It provides parameters for the subsequent functions blocks for scaling the measured currents.
- It performs the basic calculations
 - Fourier basic harmonic magnitude and angle,
 - True RMS value.

4.3.1.1.1. Parameter setting

4.3.1.1.1.1. Summary of the parameters

The parameters of the current input function are explained in the following tables.

Enumerated parameters

Parameter name	Title	Selection range	Default
Rated secondary current of the first three input channels. 1A or 5A is selected by parameter setting, no hardware modification is needed.			
CT4_Ch13Nom_EPar_	Rated Secondary I1-3	1A,5A	1A
Rated secondary current of the fourth input channel. 1A or 5A (0.2A, 1A) is selected by parameter setting, no hardware modification is needed.			
CT4_Ch4Nom_EPar_	Rated Secondary I4	1A,5A (0.2A, 1A)	1A
Definition of the positive direction of the first three currents, given by location of the secondary star connection point			
CT4_Ch13Dir_EPar_	Starpoint I1-3	Line,Bus	Line
Definition of the positive direction of the fourth current, given as normal or inverted			
CT4_Ch4Dir_EPar_	Direction I4	Normal,Inverted	Normal

Table 1-1 The enumerated parameters of the current input function

Floating point parameters

Parameter name	Title	Dim.	Min	Max	Default
Rated primary current of channel1-3					
CT4_PriI13_FPar_	Rated Primary I1-3	A	100	4000	1000
Rated primary current of channel4					
CT4_PriI4_FPar_	Rated Primary I4	A	100	4000	1000

Table 1-2 The floating point parameters of the current input function



NOTE: The rated primary current of the channels is not needed for the current input function block itself. These values are passed on to the subsequent function blocks.

4.3.1.1.1.2. Setting the rated secondary current

The scaling of the currents (even hardware scaling) depends on parameter setting.

Rated Secondary I1-3 and Rated Secondary I4

Select the rated secondary current according to the nominal data of the main current transformer. The options to choose from are 1A or 5A (in special applications, 0.2A or 1A). This parameter influences the internal number format and, naturally, accuracy. (A small current is processed with finer resolution if 1A is selected.) The first parameter is common for the first three channels and the second one is applied for the fourth channel.

NOTE: when selecting from the available choice, no hardware modification is needed.

4.3.1.1.1.3. Setting the positive direction of the currents

The positive direction of the currents influences the correct operation of directionality (e.g. distance protection, directional overcurrent protection, power calculation, etc.) If needed, the currents can be inverted by setting parameters. This is equivalent to interchanging the two wires, connecting the currents to the inputs.

Starpoint I1-3 and Direction I4.

Starpoint I1-3 applies to each of the channels IL1, IL2 and IL3. The example of Figure 1-1 below shows the connection and the correct parameter setting for Starpoint I1-3=Line. The current L1 is connected to terminal No1 of the CT input, the current L2 to No3, and the current L3 to No5. The common point of the CT inputs is the connected No2-No4-No6. This point leads the residual current to the input No7. The connection point No8 is connected with the fourth wire to the star-point of the CTs. This application of the fourth channel is the "Normal" direction.

If the currents are connected not this way then change the parameter values accordingly.

4.3.1.1.1.4. Setting the rated primary current

These parameters are needed only to display the currents (and powers) in primary scale. The protection function apply secondary values, these parameters are not needed for protection functions.

Rated Primary I1-3 and Rated Primary I-4

Select the rated primary currents according to the nominal data of the main current transformers. The first parameter (Rated Primary I1-3) is common for the first three channels and the second (Rated Primary I-4) is for the fourth channel.

4.3.1.1.2. Application of the on-line measurements in commissioning

The **measured values** of the current input function block are listed and explained in the Table below.

Measured value	Dim.	Explanation
Current Ch - I1	A(secondary)	Fourier basic component of the current in channel IL1
Angle Ch - I1	degree	Vector position of the current in channel IL1
Current Ch - I2	A(secondary)	Fourier basic component of the current in channel IL2
Angle Ch - I2	degree	Vector position of the current in channel IL2
Current Ch - I3	A(secondary)	Fourier basic component of the current in channel IL3
Angle Ch - I3	degree	Vector position of the current in channel IL3
Current Ch - I4	A(secondary)	Fourier basic component of the current in channel IL4
Angle Ch - I4	degree	Vector position of the current in channel IL4

Table 1-3 The measured analogue values of the current input function

NOTE1: The scaling of the Fourier basic component is such that if pure sinusoid 1A RMS of the rated frequency is injected, the displayed value is 1A.

NOTE2: The reference of the vector position depends on the device configuration. If a voltage input module is included, then the reference vector (vector with angle 0 degree) is the vector calculated for the first voltage input channel of the first applied voltage input module. If no voltage input module is configured, then the reference vector (vector with angle 0 degree) is the vector calculated for the first current input channel of the first applied current input module. (The first input module is the one, located closer to the CPU module.)

4.3.1.1.3. Examples

When the vector position of the currents are relevant (e.g. distance protection, directional overcurrent protection, power measurement, etc.) then mind the correct connection of the instrument transformers and the related parameter setting. If the wires of the secondary cables are interchanged then change also the related parameter values.

4.3.1.1.3.1. Residual current measurement

Figure 1-1 shows a connection example with 3I₀ measurement. The star-point of the CT-s is towards the line, L1 is connected to terminal No1 of the CT input, L2 to No3, L3 to No5.

The common point of the CT inputs is the connected No2-No4-No6. This point leads the residual current to the input No7. The connection point No8 is connected with the fourth wire to the star-point of the CTs.

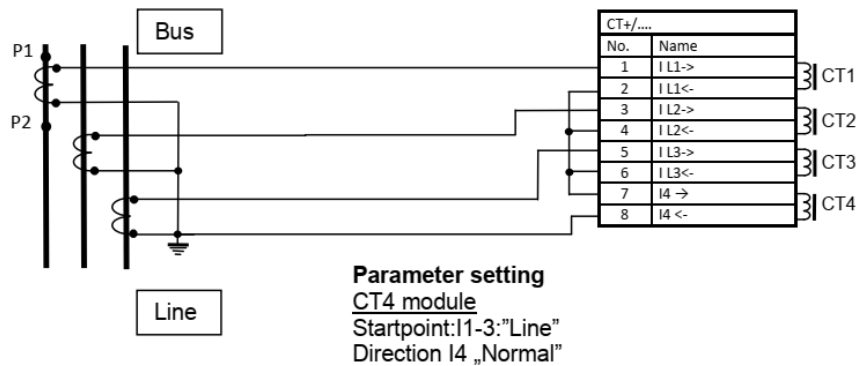

Figure 1-1 Example: CT connection with 3I₀ measurement

The related proposed parameter setting is the screen-shot of Figure 1-2. Parameter “Starpoint I1-3” is set to “Line”, indicating that the star-point is toward the protected object (line). The parameter “Direction I4” is set to “Normal”, indicating that the residual current flows in to terminal No7 and the star point of the primary current transformer is toward the protected object (line).

	Device value (Default_set_1)	New value		
Rated Secondary I1-3	1A	1A		
Rated Secondary I4	1A	1A		
Starpoint I1-3	Line	Line		
Direction I4	Normal	Normal		
Rated Primary I1-3	1000	1000	A	(100 - 4000 / 1)
Rated Primary I4	1000	1000	A	(100 - 4000 / 1)

Figure 1-2 Example: Parameter setting, according to Figure 1-1

In case of normal operation of the network, the correct connection of the CT-s and the related parameter setting can be checked using the “On-line” measurements. Disconnect one phase of the protected line, e.g. L1. The expected result is shown in Figure 1-3. The current is missing in phase L1 (Current Ch-I1 = 0) and the measured 3I₀ value is the vector sum of the remaining I₂+I₃. (Value of “Current Ch - I4” with the related “Angle - I4”).

NOTE: If in this test, only the secondary current is disclosed using a short measuring cable, then the measured current in this phase is usually not zero, due to the current distribution between the low-impedance input and the impedance of the measuring cable. For correct result, additionally to the short-circuit, also the disconnection of this input is needed. In this example the reference vector is the vector of the first voltage channel (not shown in the screenshot).

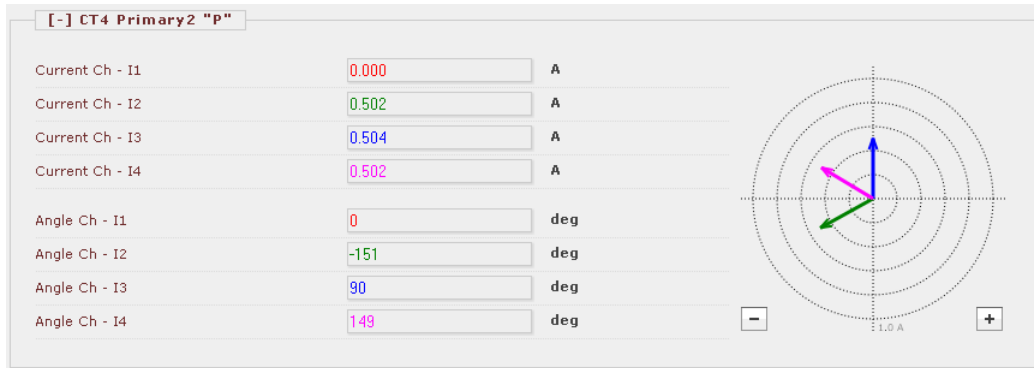

Figure 1-3 Example: Checking the current connection

4.3.1.1.3.2. Application of core-balanced CT

Figure 1-4 shows a connection example with 3I₀ measurement. The star-point of the CT-s is towards the line, L1 is connected to terminal No1 of the CT input, L2 to No3, L3 to No5. The common point of the CT inputs is the connected No2-No4-No6. The separately measured residual current is connected with the same polarity to terminals 7-8.

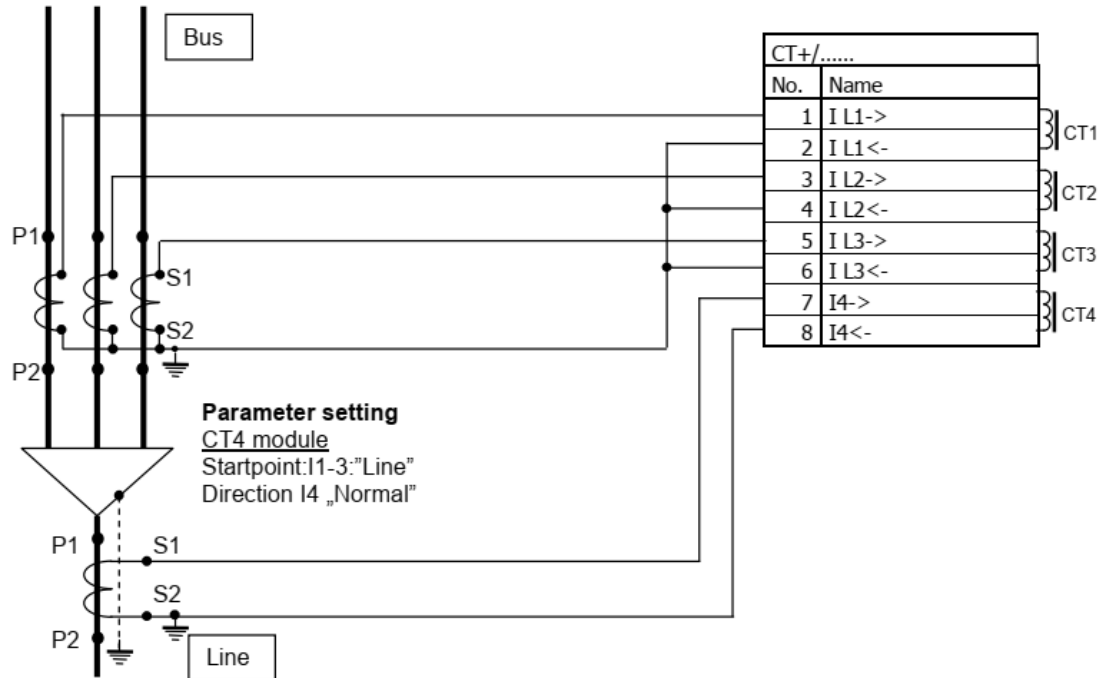

Figure 1-4 Example: CT connection with core-balance CT application

This figure also indicates the proposed parameter values for this connection. The checking is similar to that, shown in Figure 1-3.

4.3.2. AIC current input function

4.3.2.1. Application of the AIC current input function

If the factory configuration includes an AIC input hardware module, the AIC current input function block is automatically configured among the software function blocks. Separate current input function blocks are assigned to each AIC current input hardware module.

The AIC current input module accepts transducers current outputs. The AIC module has four channels, they can measure unipolar and bipolar current values in wide ranges. (See EuroProt+ hardware description document.) The transducer converts any physical quantity to DC current values.

The transmitters can be connected by wiring methods, shown in Figure 1–1, Figure 1–2 and Figure 1–3.

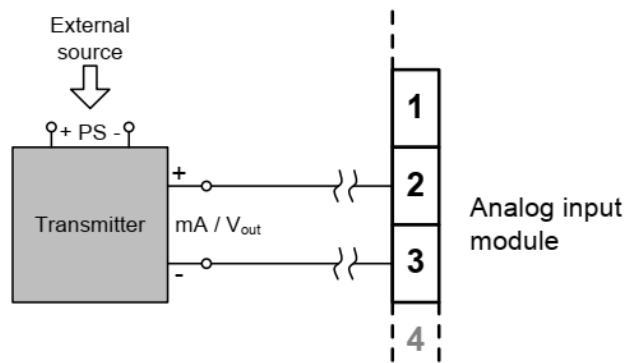

Figure 1–1 2-wire AIC wiring without 12 V excitation

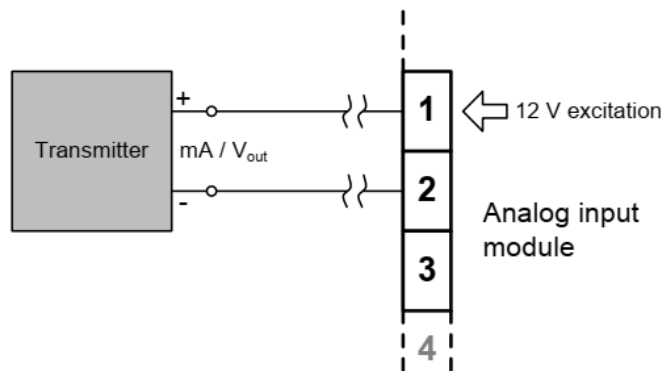

Figure 1–2 2-wire AIC wiring with 12 V excitation

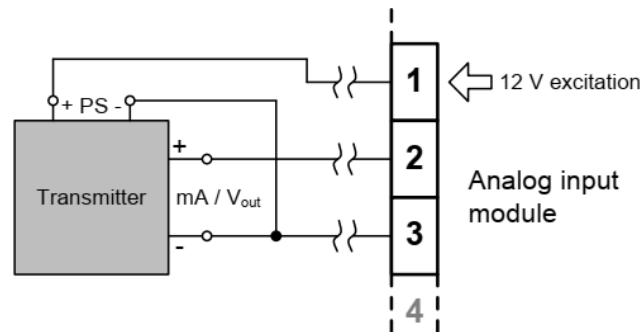

Figure 1–3 3-wire AIC wiring with 12 V excitation

The channels of the module are independent of each other. To each channel a dedicated measuring module is assigned. These measuring modules are described in a separate document: “**GGIOmA current measurement module function block description**”.

4.3.2.2. Technical summary

4.3.2.2.1. Technical data

The technical data of the AIC analog current input module are related to the hardware module. This is described in the document “**EuroProt+ Hardware description**, Chapter 11: analog input module”.

4.3.2.2.2. Summary of the parameters

The parameters of the AIC analog current input function are explained in the following table.

Enumerated parameters

Parameter name	Title	Selection range	Default
Polarity of Channel 1			
AIC_Ch1Dir_EPar_1	Direction - Ch1	Normal,Inverted*	Normal
Polarity of Channel 2			
AIC_Ch2Dir_EPar_1	Direction – Ch2	Normal,Inverted*	Normal
Polarity of Channel 3			
AIC_Ch3Dir_EPar_1	Direction – Ch3	Normal,Inverted*	Normal
Polarity of Channel 4			
AIC_Ch4Dir_EPar_1	Direction – Ch4	Normal,Inverted*	Normal

*Figures 1-1, 1-2 and 1-3 show “Normal” connection polarity

Table 1-1 The enumerated parameters of the current input function

NOTE: The function block has no input and output binary signals, the graphic logic editor does not show this function block.

4.3.3. Voltage input function

4.3.3.1. Application of the voltage input function

The application of the voltage inputs depends on the correct connection of the hardware terminals and also on the correct parameter setting for the VT4 function block. This guide describes examples, based on which any other combinations can be realized.

In the applications of the voltage transformer hardware module, the first three voltage inputs receive the three phase voltages (UL1, UL2, UL3), the fourth input is reserved for zero sequence voltage, for the busbar voltage if synchronized switching is applied or for any additional voltages. Accordingly, the first three inputs have common parameters while the fourth voltage input needs individual setting.

The VT4 function block is an independent module in the sense that:

- It has independent parameters to be set, associated to the voltage inputs,
- It delivers the sampled voltage values for protection, measurement function blocks and for disturbance recording,
- It provides parameters for the subsequent functions blocks for scaling the measured voltages.
- It performs the basic calculations
 - Fourier basic harmonic magnitude and angle,
 - True RMS value.

4.3.3.1.1. Parameter setting

4.3.3.1.1.1. Summary of the parameters

The parameters of the voltage input function are explained in the following tables.

Enumerated parameters

Parameter name	Title	Selection range	Default
Rated secondary voltage of the input channels. 100 V or 200V is selected by parameter setting, no hardware modification is needed.			
VT4_Type_EPar_	Range	Type 100,Type 200	Type 100
Connection of the first three voltage inputs (main VT secondary)			
VT4_Ch13Nom_EPar_	Connection U1-3	Ph-N, Ph-Ph, Ph-N-Isolated	Ph-N
Selection of the fourth channel input: phase-to-neutral or phase-to-phase voltage			
VT4_Ch4Nom_EPar_	Connection U4	Ph-N,Ph-Ph	Ph-Ph
Definition of the positive direction of the first three input channels, given as normal or inverted			
VT4_Ch13Dir_EPar_	Direction U1-3	Normal,Inverted	Normal
Definition of the positive direction of the fourth voltage, given as normal or inverted			
VT4_Ch4Dir_EPar_	Direction U4	Normal,Inverted	Normal

Table 1-1 The enumerated parameters of the voltage input function

Integer parameter

Parameter name	Title	Unit	Min	Max	Step	Default
Voltage correction						
VT4_CorrFact_IPar_	VT correction	%	100	115	1	100

Table 1-2 The integer parameter of the voltage input function



Floating point parameters

Parameter name	Title	Dim.	Min	Max	Default
Rated primary voltage of channel 1, 2, 3					
VT4_PriU13_FPar	Rated Primary U1-3	kV	1	1000	100
Rated primary voltage of channel 4					
VT4_PriU4_FPar	Rated Primary U4	kV	1	1000	100

Table 1-3 The floating point parameters of the voltage input function

NOTE: The rated primary voltage of the channels is not needed for the voltage input function block itself. These values are passed on to the subsequent function blocks.

4.3.3.1.1.2. Setting the rated secondary voltage

The scaling of the voltage depends on parameter setting.

Range

There are basically two standard voltage transformer types: one with secondary rated voltage 100 V, the other with 200 V. Select the parameter value respectively: Type 100, Type 200. No hardware modification is needed. This parameter influences the internal number format and, naturally, accuracy. (A small voltage is processed with finer resolution if 100V is selected.)

VT correction

In some cases the rated secondary of the voltage transformers is not 100V but e.g. 110 V. This parameter is to correct this difference, if the rated secondary voltage of the main voltage transformer does not match the rated input of the device. As an example: if the rated secondary voltage of the main voltage transformer is 110V, then select Type 100 for the parameter "Range" and the required value to set here is 110%.

4.3.3.1.1.3. Setting the connection and the positive direction of the voltages

The connection and direction parameters of the first three VT secondary windings must be set to reflect actual physical connection of the main VTs.

Connection U1-3.

The selection can be: "Ph-N", "Ph-Ph" or "Ph-N-Isolated".

The *Ph-N* option is applied in solidly grounded networks, where the measured phase voltage is never above $1.5 \cdot U_n$. In this case the primary rated voltage of the VT must be the value of the rated PHASE-TO-NEUTRAL voltage.

The *Ph-N-Isolated* option is applied in compensated or isolated networks, where the measured phase voltage can be above $1.5 \cdot U_n$ even in normal operation. In this case the primary rated voltage of the VT must be the value of the rated PHASE-TO-PHASE voltage.

The *Ph-Ph* option is to be selected if phase-to-phase voltage is connected to the VT input of the device. Here, the primary rated voltage of the VT must be the value of the rated PHASE-TO-PHASE voltage. This option must not be selected if the distance protection function or directional overcurrent protection function is supplied from the VT input.

Connection U4



The fourth input is reserved for zero sequence voltage or for a voltage from the other side of the circuit breaker for synchronized switching. Accordingly, the connected voltage must be identified with parameter setting Connection U4. Here, phase-to-neutral or phase-to-phase voltage can be selected: “Ph-N”, “Ph-Ph”

Direction U1-3

If needed, the phase voltages can be inverted by setting the parameter Direction U1-3. This selection applies to each of the channels UL1, UL2 and UL3. The primary/secondary connection of the VT windings is generally star/star connected and the phase voltages signed with • are connected to the VT4 terminals 1-3-5. In this case the parameter setting is „Normal”. Select “Inverted” to the parameter Direction U1-3 in case of inverted connection of phase voltages.” (See also Figure 1-1 in setting example.)

Direction U4

This parameter applies to the channel UL4. If the voltage signed with • is connected to the VT4 terminal 7 the parameter setting is „Normal”. Select “Inverted” to the parameter Direction U4 in case of inverted connection of the voltage. This inversion may be needed in protection functions such as distance protection or for any functions with directional decision, or for checking the voltage vector positions.

Figure 1-1 shows an example with harmonized connection and parameter setting.

If the voltages are connected not this way then change the parameter values accordingly.

4.3.3.1.1.4. Setting the rated primary voltage

These parameters are needed only to display the voltages (and powers) in primary scale. The protection functions apply secondary values, these parameters are not needed for protection functions.

Rated Primary U1-3 and Rated Primary U-4

Select the rated primary voltages according to the nominal data of the main voltage transformers. The two parameters are: common for the first three channels and one for the fourth channel respectively.

4.3.3.1.2. Application of the on-line measurements in commissioning

The performed basic calculation results the Fourier basic harmonic magnitude and angle value of the voltages. These results are processed by subsequent protection function blocks and they are available for on-line displaying as well.

4.3.3.1.2.1. Summary of the on-line measurements

The **measured values** of the voltage input function block.

Measured value	Dim.	Explanation
Voltage Ch - U1	V(secondary)	Fourier basic component of the voltage in channel UL1
Angle Ch - U1	degree	Vector position of the voltage in channel UL1
Voltage Ch - U2	V(secondary)	Fourier basic component of the voltage in channel UL2
Angle Ch - U2	degree	Vector position of the voltage in channel UL2
Voltage Ch - U3	V(secondary)	Fourier basic component of the voltage in channel UL3
Angle Ch - U3	degree	Vector position of the voltage in channel UL3
Voltage Ch - U4	V(secondary)	Fourier basic component of the voltage in channel U4
Angle Ch - U4	degree	Vector position of the voltage in channel U4

Table 1-4 The measured analogue values of the voltage input function

NOTE1: The scaling of the Fourier basic component is such that if pure sinusoid 57V RMS of the rated frequency is injected, the displayed value is 57V.

NOTE2: The reference vector (vector with angle 0 degree) is the vector calculated for the first voltage input channel of the first applied voltage input module. (The first voltage input module is the one, configured closer to the CPU module.)

4.3.3.1.3. Examples

When the vector position of the voltages are relevant (e.g. distance protection, directional overcurrent protection, power measurement, synchrocheck, etc.) then mind the correct connection of the instrument transformers and the related parameter setting. If the wires of the secondary cables are interchanged then change also the related parameter values.

4.3.3.1.3.1. Phase voltage and residual voltage measurement

Figure 1-1 shows the phase voltage measurement and also the residual voltage measurement e.g. for residual directional overcurrent protection function. In this example the residual voltage is measured in open delta of the VT secondary coils. The network is supposed to be compensated. This figure also indicates the proposed parameter values.

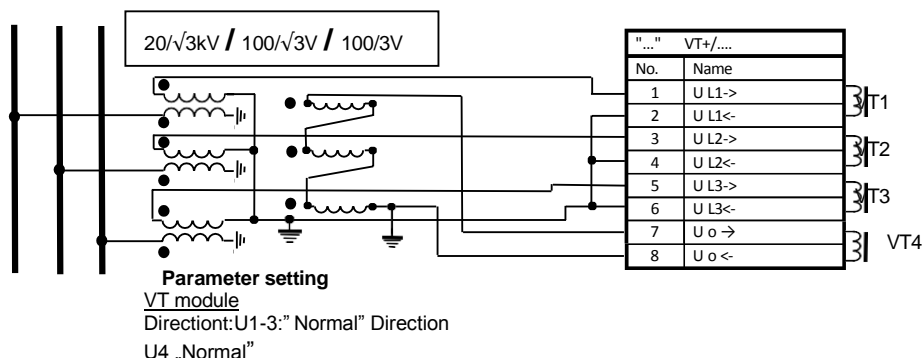

Figure 1-1 Example: Phase voltage and residual voltage measurement

Range	Type 100	The type indicates the rated secondary voltage of the VT. This can be 100 V (in this example) or 200V
Connection U1-3	Ph-N-Isolated	This indicates that the VT primary is connected between the conductor and the ground (in this example in compensated network). This could be Ph-N or Ph-Ph in other application. (NOTE: If the neutral of the system is not grounded, select Ph-N-Isolated)
Connection U4	Ph-Ph	In case of earth fault the open delta measures 100 V. This corresponds to the phase-to-phase value
Direction U1-3	Normal	Figure 1-1 shows the normal VT connection, i.e. the signed • phase wires are connected to the terminals 1-3-5. (Select "Inverted" in case of inverted connection.)
Direction U4	Normal	Figure 1-1 shows the normal VT connection, i.e. the signed • wire of the open delta of VT-s is connected to the terminal 7. (Select "Inverted" in case of inverted connection.)
VT correction	100	If the rated secondary value of the VT is e.g. 110 V then select this correction value to 110%.
Rated Primary U1-3	20	Setting, according to the VT rated voltage, applied at the primary side. This parameter is used for scaling the displayed values only.
Rated Primary U4	11.55	This parameter is used for scaling the displayed values only. In case of earth fault, the open delta measures 100 V. In primary value it is displayed as the phase voltage in the 20 kV network.

Table 1-5 Example parameters for the voltage input function

4.3.3.1.3.2. Syncrocheck using phase-to neutral voltage

Figure 1-2 shows the application of the fourth voltage input of the VT module for syncrocheck function. Here UL2 of the busbar voltage is used for this purpose.

NOTE: Among syncrocheck parameters set "Voltage select" parameter to "L2-N".

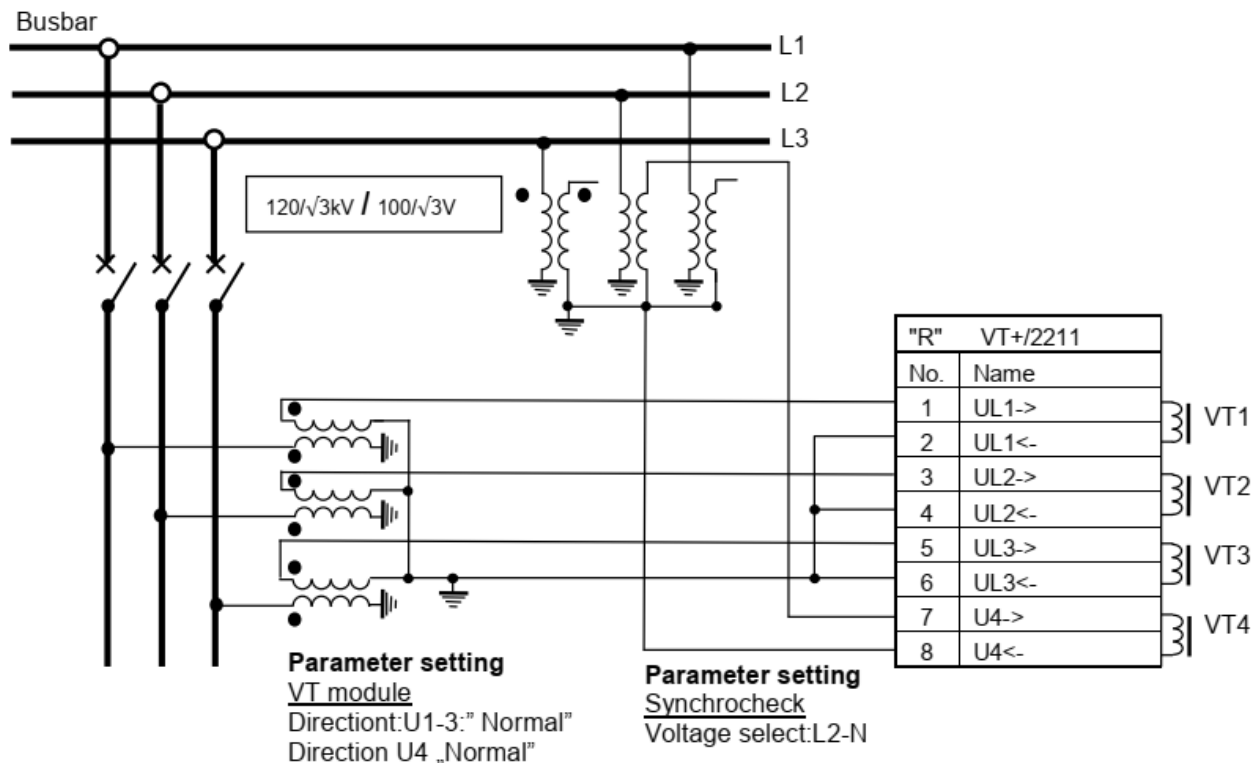

Figure 1-2 Example: Syncrocheck, using phase-to-neutral voltage

Figure 1-3 shows the screenshot indicating the proposed parameter values.

	Device value (Default_set_1)	New value		
Range	Type 100	Type 100		
Connection U1-3	Ph-N	Ph-N		
Connection U4	Ph-N	Ph-N		
Direction U1-3	Normal	Normal		
Direction U4	Normal	Normal		
VT correction	100	100	%	(100 - 115 / 1)
Rated Primary U1-3	69.28	69.28	kV	(1.00 - 1000.00 / 0.01)
Rated Primary U4	69.28	69.28	kV	(1.00 - 1000.00 / 0.01)

Figure 1-3 Example:Parameters for syncrocheck, using phase-to-neutral voltage

The "On-line window" of the VT4 input module shows the checking the correct voltage vector position. When the line is connected to the busbar, i.e. the CB is closed, in this example the U4 voltage is expected to have the same value and position as U2. See Figure 1-4.



Figure 1-4 Example: On-line measurement for synchrocheck, using phase-to-neutral voltage

4.3.3.1.3.3. Synchrocheck using phase-to-phase voltage

Figure 1-5 shows the application of the fourth voltage input of the VT module for synchrocheck function. Here UL1-UL3 line-to-line signal of the busbar voltage is used for this purpose.

NOTE: Among synchrocheck parameters set "Voltage select" parameter to "L3-L1". This selection is opposite to that, of the connected voltage. This can be corrected selecting the "Direction U4" parameter value to "Inverse".

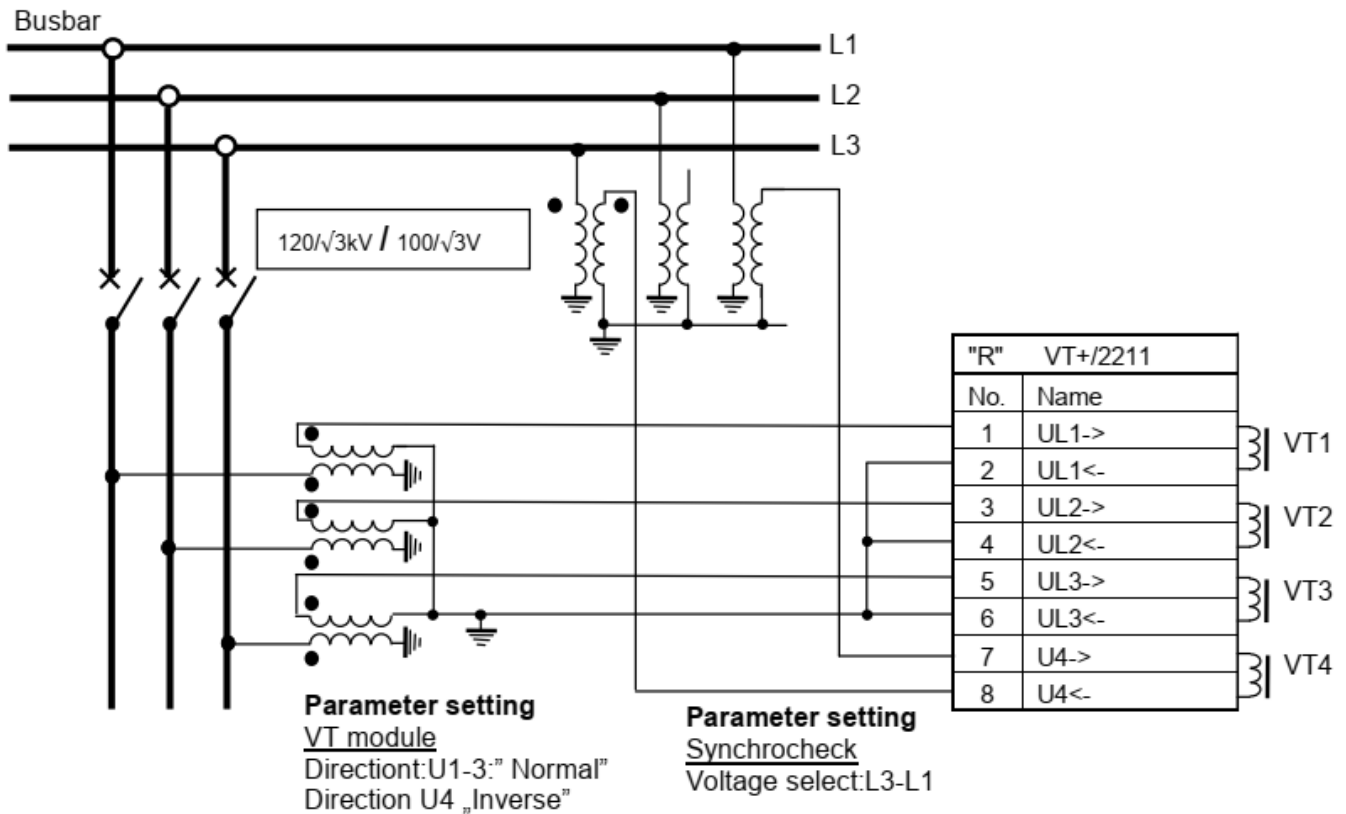

Figure 1-5 Example: Synchrocheck, using phase-to-phase voltage

Figure 1-6 shows the proposed parameter values for the connection shown above.

4.3.4.3. The measurement

4.3.4.3.1. The measured values; variants of the function

There are six variants of the MXU function, based on their **measured values**. Parameters and measurements are alike for each. The **type of the variant** is shown in the *function block name*:

- Line Measurement (*MXU_LM*)
- Frequency Measurement (*MXU_F*)
- Voltage measurement (*MXU_V*)
- Voltage measurement (*MXU_V1*) (single voltage)
- Current measurement (*MXU_C*)
- Current measurement (*MXU_C1*) (single current)

Table 1-1 Measured values of each variant

ON-LINE MEASURED VALUE	EXPLANATION	MXU FUNCTION BLOCK VARIANT					
		LM	F	V	V1	C	C1
MXU_P_OLM_	Active Power – P (Fourier base harmonic value)	X					
MXU_Q_OLM_	Reactive Power – Q (Fourier base harmonic value)	X					
MXU_S_OLM_	Apparent Power – S (Fourier base harmonic value)	X					
MXU_Fi_OLM_	Power factor	X					
MXU_I1_OLM_	Current L1	X				X	X
MXU_I2_OLM_	Current L2	X				X	
MXU_I3_OLM_	Current L3	X				X	
MXU_Ipos_OLM_	Calculated positive seq. current	X				X	
MXU_Ineg_OLM_	Calculated negative seq. current	X				X	
MXU_3Io_OLM_	Calculated 3Io	X				X	
MXU_U1_OLM_	Voltage L1	X		X	X		
MXU_U2_OLM_	Voltage L2	X		X			
MXU_U3_OLM_	Voltage L3	X		X			
MXU_U12_OLM_	Voltage L12	X		X			
MXU_U23_OLM_	Voltage L23	X		X			
MXU_U31_OLM_	Voltage L31	X		X			
MXU_Upos_OLM	Calculated positive seq. voltage	X		X			
MXU_Uneg_OLM_	Calculated negative seq. voltage	X		X			
MXU_3Uo_OLM_	Calculated 3Uo	X		X			
MXU_f_OLM_	Frequency		X	X			

4.3.4.3.2. The measurement modes

Regarding the power measurements there are two possibilities for the measurement modes. The first one is the “ThreePhase”-method, where all three measured voltages and currents are considered in the power calculation. The second one is the “Aron”-method, where two phase-to-phase voltages and two phase currents are taken into the calculation. This method has correct results only in case when the voltages and currents are symmetrical. The user can choose the mode with the “Measurement mode” parameter. For the “Aron”-method there are three options:

Table 1-2 Explanation for the Aron measurement modes

Measurement mode	Used phase-currents	Used phase-to-phase voltages
Aron L2-L3	L2, L3	L1-L2, L3-L1
Aron L3-L1	L1, L3	L1-L2, L2-L3
Aron L1-L2	L1, L2	L2-L3, L3-L1



If the “Connection U1-3” parameter of the *VT4 module* function block is set to “Ph-Ph”, the “ThreePhase”-method cannot be used for the power measurements here, so either of the “Aron” methods must be set for it. Otherwise, the device will provide a warning signal (yellow Status LED, “General param. error” message).

4.3.4.4. Reporting the measured values and the changes

It is usual for the SCADA systems that they sample the measured and calculated values in regular time periods and additionally they receive the changed values as reports at the moment when any significant change is detected in the primary system. The “Line measurement” function block performs such reporting for the SCADA system. Three parameters define this reporting:

- *Report Deadband* for choosing the type of reporting, or disabling the reporting
- *Deadband Value* for defining the deadband width
- *Range (value)* for evaluating the “out-of-range” condition

The usage of these parameters is explained in the following chapters.

4.3.4.4.1. “Amplitude” mode of reporting

If the “Amplitude” mode is selected for reporting, a report is generated if the measured value leaves the deadband around the previously reported value. As an example, [Figure 1-1](#) shows that the current becomes higher than the value reported in “report1” PLUS the Deadband value, this results “report2”, etc.

For this mode of operation, the Deadband parameters are explained in the figure below.

NOTE: The “Range” parameters are needed to evaluate a measurement as “out-of-range”.

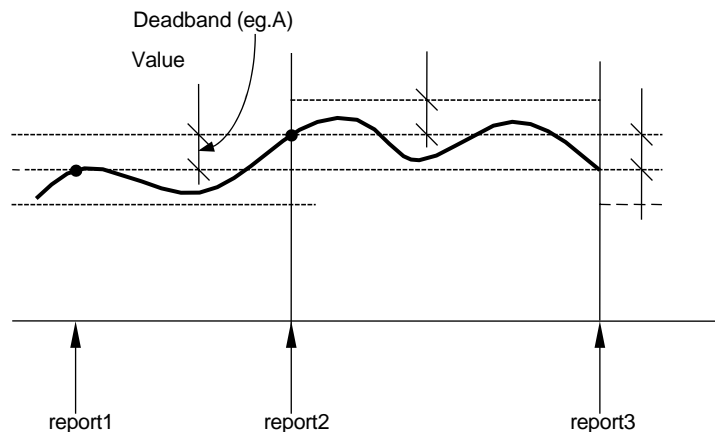

Figure 1-1 Reporting if “Amplitude” mode is selected

4.3.4.4.2. “Integrated” mode of reporting

If the “Integrated” mode is selected for reporting, a report is generated if the time integral of the measured value since the last report gets becomes larger, in the positive or negative direction, then the (deadband*1 sec) area. As an example, [Figure 1-2](#) shows that the integral of the current in time becomes higher than the Deadband value multiplied by 1sec, this results “report2”, etc.

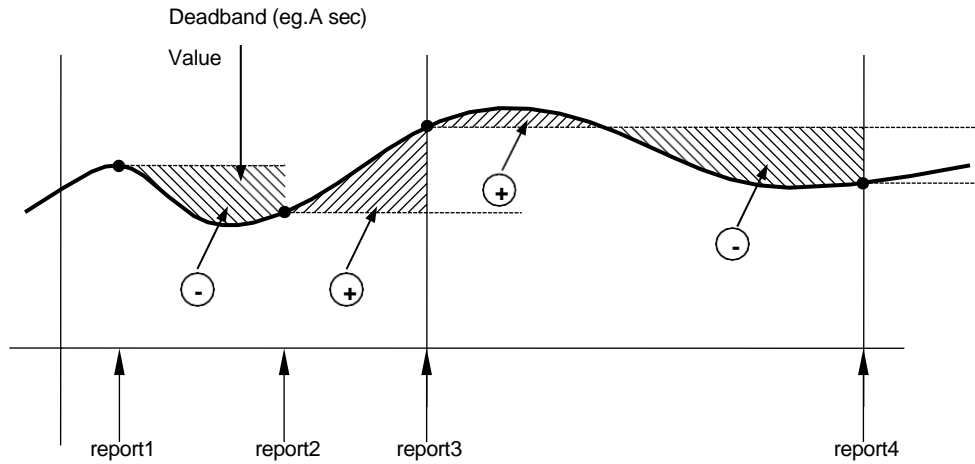

Figure 1-2 Reporting if “Integrated” mode is selected

4.3.4.4.3. Periodic reporting

Periodic reporting is generated independently of the changes of the measured values when the defined time period elapses. If the reporting time period is set to 0, then no periodic reporting is performed for this quantity.

Applying periodic reporting and setting up its interval is done by using the **Communication configurator**, a part of the **EuroCAP** software (see its description for detailed information).

Once the “Trigger period” property is set to “True”, the “Integrity period” setting becomes available to set (in milliseconds). As an example, see the picture below.

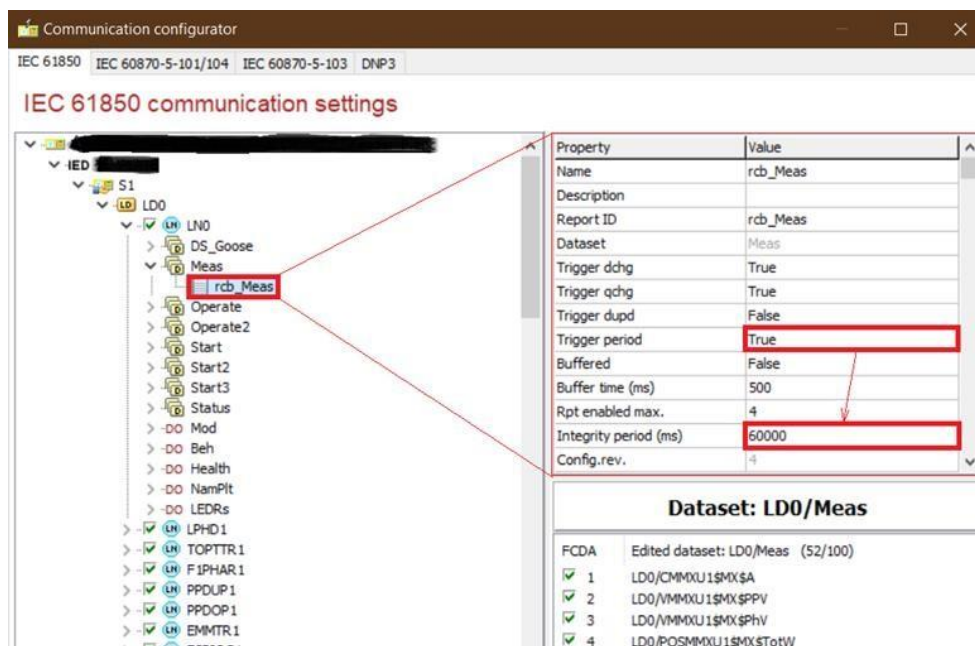

Figure 1-3 Setting up periodic reporting in EuroCAP



4.3.4.4.4. Zero-point clamping

A measured value under the zero-point clamping limit is cut off to zero.

- Three-phase current measurement 0.2% of nominal (I_n)
- Three-phase voltage measurement 2% of nominal (U_n)
- Residual current measurement 0.2% of nominal (I_n)
- Residual voltage measurement 2% of nominal (U_n)
- Phase sequence current measurement 0.2% of the nominal (I_n)
- Phase sequence voltage measurement 2% of the nominal (U_n)
- Three-phase power and energy measurement 0.23% of the nominal (S_n)

Range Value - Ipos	A	1 – 5000	1	500	Range value for the positive seq. current
Report Deadband - P	-	Off, Amplitude, Integrated	-	Amplitude	Selection of the reporting mode for active power measurement
Deadband Value - P	kW*	0.10 – 10000.00	0.01	10	Deadband value for the active power
Range Value - P	kW*	1.00 – 100000.00	0.01	500	Range value for the active power
Report Deadband - Q	-	Off, Amplitude, Integrated	-	Amplitude	Selection of the reporting mode for reactive power measurement
Deadband Value - Q	kVAr*	0.10 – 10000.00	0.01	10	Deadband value for the reactive power
Range Value - Q	kVAr*	1.00 – 100000.00	0.01	500	Range value for the reactive power
Report Deadband - S	-	Off, Amplitude, Integrated	-	Amplitude	Selection of the reporting mode for apparent power measurement
Deadband Value - S	kVA*	0.10 – 10000.00	0.01	10	Deadband value for the apparent power
Range Value - S	kVA*	1.00 – 100000.00	0.01	500	Range value for the apparent power
Report Deadband	Hz	Off, Amplitude, Integrated	-	Amplitude	Selection of the reporting mode for frequency measurement
Deadband Value	Hz	0.01 – 1.00	0.01	0.03	Deadband value for the frequency
Range Value	Hz	0.05 – 10.00	0.01	5	Range value for the frequency

**the prefixes can change (i.e. kW→MW, kV→V etc.) depending on the configuration; changing these is done by Protecta personnel*

***if the setting range is to be extended, contact Protecta personnel*

4.3.4.5.2. Function I/O

This section describes briefly the analogue and digital inputs and outputs of the function block.

4.3.4.5.2.1. Analogue inputs

The analogue inputs of the measurement functions are

- the Fourier components and true RMS values of the measured and calculated secondary voltages
- the Fourier components and true RMS values of the measured secondary currents,

4.3.4.5.2.2. Analogue outputs (measurements)

See the next chapter (On-line data) for the listing of all measurements. Note again, that the measured values depend on the type of the actual measurement function block, see Chapter [1.3.1](#)

4.3.4.5.2.3. On-line data

The **on-line data** of the line measurement function depend on the available analogue values which are referring to the applied hardware configuration.

Visible values on the on-line data page:

Table 2-2 On-line data of the line measurement function

SIGNAL TITLE	DIMENSION	EXPLANATION
Power - P	kW*	Calculated three-phase active power
Reactive Power - Q	kVAr*	Calculated three-phase reactive power
Apparent Power - S	kVA*	Calculated three-phase apparent power
Power factor	-	Calculated power factor
Current L1	A	Measured primary current L1 based on the nominal values of the CT4 current input function
Current L2	A	Measured primary current L2 based on the nominal values of the CT4 current input function
Current L3	A	Measured primary current L3 based on the nominal values of the CT4 current input function
Positive sequence current	A	Calculated positive sequence current from the three phase currents
Negative sequence current	A	Calculated negative sequence current from the three phase currents
Calculated 3I ₀	A	Calculated 3I ₀ from the three phase currents
Voltage L1	kV*	Measured primary L1 phase voltage L1 based on the nominal values of the VT4 voltage input function
Voltage L2	kV*	Measured primary L2 phase voltage L2 based on the nominal values of the VT4 voltage input function
Voltage L3	kV*	Measured primary L3 phase voltage L3 based on the nominal values of the VT4 voltage input function
Voltage L12	kV*	Calculated L12 phase-to-phase voltage
Voltage L23	kV*	Calculated L23 phase-to-phase voltage
Voltage L31	kV*	Calculated L31 phase-to-phase voltage
Positive sequence voltage	kV*	Calculated positive sequence voltage from the three phase voltages
Negative sequence voltage	kV*	Calculated negative sequence voltage from the three phase voltages
Calculated 3U ₀	kV*	Calculated 3U ₀ from the three phase voltages
Frequency	Hz	Measured frequency

**the prefixes may be different (i.e. kW→MW, kV→V etc.) depending on the configuration; changing these is done by Protecta personnel*

4.3.4.5.3.1. Notes for testing

If there are no measurements seen on the SCADA software, check the Report Deadband parameter and/or the settings of the periodic reporting in the Communication Configurator. The former's default value is 'Off', and the latter's is 'False', which means that by default, the reporting is disabled. It must be enabled first.

The **periodic reporting** is defined in the device configuration file (.epc/.epcs) using EuroCAP. See Chapter [1.4.3](#). This also means that changing the properties of this will require loading a new configuration file to the device (hence a full device restart).



If the "Connection U1-3" parameter of the *VT4 module* function block is set to "Ph-Ph", the "ThreePhase"-method cannot be used for the power measurements here, so either of the "Aron" methods must be set for it. Otherwise, the device will provide a warning signal (yellow Status LED, "General param. error" message).

For the devices shipped with modules manufactured before 2020/Q2, the technical data table is different:

Table 2-7 Technical data of the line measurement function

HARDWARE MODULE	RANGE	ACCURACY
CT+/5151 or CT+/5102	0,2 In – 0,5 In	±2%, ±1 digit
	0,5 In – 20 In	±1%, ±1 digit
CT+/1500	0,03 In – 2 In	±0,5%, ±1 digit

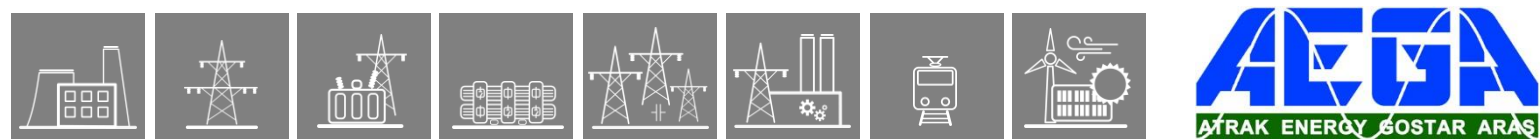

4.3.5. Average and maximum measurement function

4.3.5.1. The measurement

The input values of the EuroProt+ devices are the secondary signals of the voltage transformers and those of the current transformers.

These signals are pre-processed by the “Voltage transformer input” function block and by the “Current transformer input” function block. These function blocks are described in separate documents. The pre-processed values include the Fourier basic harmonic phasors of the voltages and currents and the true RMS values. Additionally, it is in these function blocks that parameters are set concerning the voltage ratio of the primary voltage transformers and current ratio of the current transformers.

Based on the pre-processed analog signals, several function blocks perform additional calculation, e.g.: active and reactive power, frequency, temperature, impedances, higher harmonics, symmetrical components, etc.

The “Average and maximum” function block calculates average values and locates maximum values of the assigned (measured and calculated) analog signals.

4.3.5.2. Operation of the function block

The **input** of the function can be:

- Any single calculated analog value: active and reactive power, frequency, temperature, impedances, higher harmonics, symmetrical components, etc. depending on the assignment in the configuration.

The **outputs** of the function are:

- Average of the analog value,
- Maximum of the analog value.

The average and the maximum values are automatically reported to the SCADA system. The maximum is logged and is sent automatically to the HMI, the average however is logged only if a binary input of the function block enables this activity.

4.3.5.3. Reporting the values

The average calculation needs a time span for calculation; this is given as a parameter value, set in minutes (or the function is switched off). When the timer expires, the calculated average is reported automatically to the SCADA system. Depending on the requirements, this value is also logged and is sent to the local HMI. This activity is controlled by a binary input of the function block.

The identification of the maximum value needs also a time span; this is given as a parameter value, set in days. When the timer expires, the found maximum value is reported automatically to the SCADA system. Additionally this value is also logged and is sent to the local HMI.

The starting of the timer is controlled by the internal real-time clock of the device. The moment of time for the starting of the processing cycles is set by a parameter value.

4.3.5.4. Parameters of the function block

Enumerated parameter

Parameter name	Title	Selection range	Default
Time window for averaging			
MXU_TimWin_EPar_T	Average TimeWindow	Off,5min,10min,15min,30min,60min	Off

Table 1-1 The enumerated parameters of the average and maximum measurement function

Integer parameter

Parameter name	Title	Unit	Min	Max	Step	Default
Time window for finding the maximum value						
MXU_MaxResInt_IPar_T	MaxReset Interval	day	0	365	1	1
Moment of time for reporting and reset						
MXU_MaxResTime_IPar_T	MaxReset Time	hour	0	23	1	12

Table 1-2 The integer parameters of the average and maximum measurement function

4.3.5.5. Status signals of the function block

The average and maximum measurement function block has **binary input signals**, which serve the purpose of resetting the values and enabling logging the average value. **The conditions are defined by the user, applying the graphic equation editor.**

Binary status signal	Explanation
MXU_Reset_GrO_IL1 *	This signal resets both the calculated average and the found maximum value. At the end of the running cycles, the values found during the shortened cycle will be processed.
MXU_DemHMIEna_GrO_IL1	During the active state of this signal also the calculated average value is logged

* Note: In this example "IL1" is indicating that in the instant of the function block processes the RMS value of the current in line 1

Table 1-3 The binary input signal for the average and maximum measurement function block

The average and maximum measurement function block **has no binary output signals.**

4.3.5.6. The function block

The function block of the average and maximum measurement function is shown in [Figure 1-1](#). This block shows all binary input (and output) status signals that are applicable in the graphic equation editor.

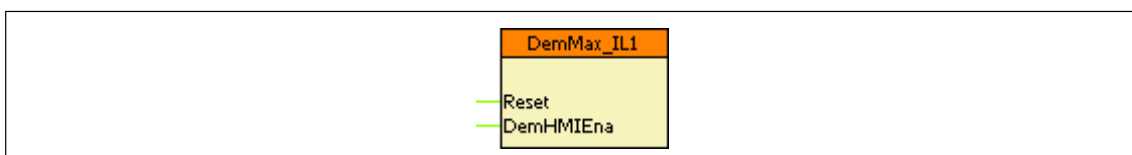
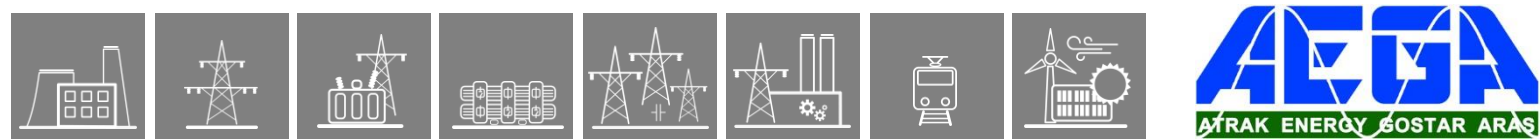

Figure 1-1 The function block of the average and maximum measurement function block



4.3.6.1.3. Impulse mode

Based on the external energy meter impulses. These impulse outputs of the meter connect as binary inputs. Metering function block calculates the active and reactive power supply and demand. These values are accumulated to obtain, separately:

- Active power demand,
- Active power supply,
- Reactive power demand.
- Reactive power supply,

Impulse scaling values are entered as parameters named “Active pulse scale” and “Reactive pulse scale”.

The time period of the accumulation is defined by parameter setting. It can be selected in a broad range. The start of the accumulation is based on the integrated real-time clock of the device. For example, for the “Time Interval” setting of 15min, the trigger is: at 0h0min, 0h15min, 0h30min, 0h45 min, 1h0min, etc.

When the accumulation time is over, the calculated values are reported to the SCADA system. The displayed values change continuously.

The calculated values are available as primary quantities and they can be displayed on the on-line screen of the device or on the webpage of the device and they are available for the SCADA system using the configured communication system

The **inputs** of the metering function are:

- the impulses of energy meter,
- parameters.

The **output** of the metering function is:

- displayed measured values.

4.3.6.1.4. Cumulation mode

“Cumulation mode” parameter defines the mode of operation. It can be “TRUE” or “FALSE”.

In “FALSE” mode the values set to zero after the values are reported to the SCADA system, based on the “Time Interval” settings.

In “TRUE” mode the values are cumulated after the report is sent to the SCADA system.

Maximum cumulated value depends on the CT module of IED and the primary nominals of CT and VT.

“Nominal primary power” = “Rated Primary U1-3” setting of VT module multiplied by “Rated Primary I1-3” setting of CT module. Unit prefix (**kilo-** or **Mega**) depends on the configuration, the “Line measurement” function uses the same unit prefix as Metering.

Maximum cumulated power value with CT+/1500 module = 3 259 602 multiplied by “Nominal primary power”

Maximum cumulated power value with CT+/5151 module = 65 192 055 multiplied by “Nominal primary power”

Maximum cumulated power value with CT+/5115 module = 8 149 006 multiplied by “Nominal primary power”

User can reset cumulated value to zero either by initiating the reset input of Metering function block or by restarting the device.



4.3.6.1.5. The measurement

4.3.6.1.5.1. Reference direction

“Reference direction” parameter setting defines the direction when voltage and current vectors are in phase. Setting can be “Demand” or “Supply”.

4.3.6.1.5.2. The measured values

Unit prefix of the **measured values** of the metering function depends on the configuration: it can be kilo or Mega. The “Line measurement” function uses the same unit prefix as the Metering.

MEASURED VALUE	EXPLANATION
MTR_PosP_OLM_	Demand kWh – active power consumption
MTR_NegP_OLM_	Supply kWh – active power supply
MTR_PosQ_OLM_	Demand kVArh – reactive power consumption
MTR_NegQ_OLM_	Supply kVArh – reactive power supply

Table 1-1 Measured values of the metering function

The measured values available are shown as on-line information, see the figure below.

[-] METERING		
Demand kWh	400.0	kWh
Supply kWh	300.0	kWh
Demand kVArh	500.0	kVArh
Supply kVArh	2500.0	kVArh

Figure 1-1 Measured values of the metering function

4.3.6.1.6. Parameter setting

The time period of accumulation is defined by parameter setting. This can be selected in a broad range, as it is shown in Table 1-2.

Enumerated parameter

PARAMETER NAME	TITLE	SELECTION RANGE	DEFAULT
Selection of the time period for power metering			
MTR_TimInt_EPar_	Time Interval	Off, 5min, 10min, 15min, 30min, 60min	30min

Table 1-2 The enumerated parameter of the metering function

4.3.6.2. Metering function overview

The graphic appearance of the function block of the metering function is shown below. The block shows all binary input and output status signals which are applicable in the graphic equation editor.

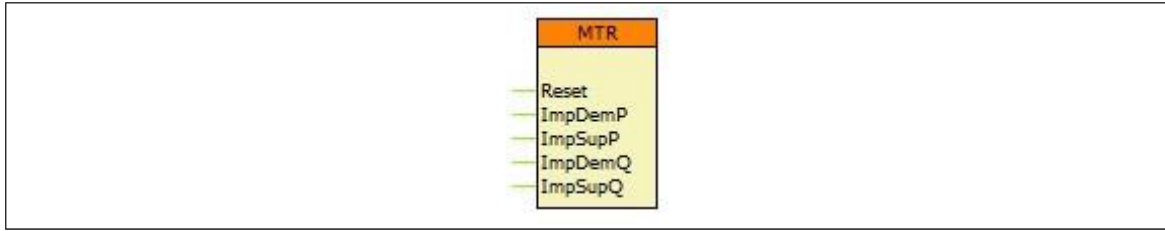

Figure 2-1 Graphic appearance of the function block of the metering function

4.3.6.2.1. Settings

4.3.6.2.1.1. Parameters

The available parameters are listed below in order of their appearance in the *parameters* menu. If the setting range of a parameter should be extended, contact Protecta Support.

Table 2-1 The available parameters of the metering function

TITLE	DIM.	RANGE	STEP	DEFAULT	EXPLANATION
Time Interval	-	Off, 5min (On), 10min , 15min , 30min , 60min	-	30min	Time period of accumulation parameter for general operation of the function:
Input selection	-	Measurement, Impulse,	-	Measurement	Input selection of energy calculation
Cumulation mode		FALSE,TRUE		FALSE	Cumulation mode is used
Reference direction	-	Demand, Supply	-	Demand	Energy direction reference selection.
Active pulse scale	kWh/ pulse	1 - 10000	1	100	One impulse of energy meter is equal to this setting
Reactive pulse scale	kVarh/ pulse	1 - 10000	1	100	One impulse of energy meter is equal to this setting

4.3.6.2.2. Function I/O

This section describes briefly the analogue and digital inputs and outputs of the function block.

4.3.6.2.2.1. Analogue inputs

The function uses the sampled values of a voltage and current inputs. This is defined in the configuration.

4.3.6.2.2.2. Analogue outputs (measurements)

The measured values of the metering function are listed in the table below.

Table 2-2 The measured analogue values of the metering function

MEASURED VALUE	DIMENSION	EXPLANATION
Demand P	kWh	<i>Demand P. Unit prefix can be kilo- or mega-, depends on the configuration</i>
Supply P	kWh	<i>Supply P. Unit prefix can be kilo- or mega-, depends on the configuration</i>
Demand Q	kVArh	<i>Demand Q. Unit prefix can be kilo- or mega-, depends on the configuration</i>
Supply Q	kVArh	<i>Supply Q. Unit prefix can be kilo- or mega-, depends on the configuration</i>

4.3.6.2.2.3. Binary input signals (graphed output statuses)

The conditions of the binary inputs are defined by the user, applying the graphic equation editor (*Logic Editor*). Parts written in **bold** are seen on the left side function block in the Logic editor.

Table 2-3 The binary input signal of the metering function

BINARY OUTPUT SIGNAL	EXPLANATION
MTR_Reset_GrO_	Reset input of the function has meaning only in cumulation mode
MTR_ImpDemP_GrO_	Demand P impulse of external energy meter input of the function has meaning only in impulse input mode
MTR_ImpSupP_GrO_	Supply P impulse of external energy meter input of the function has meaning only in impulse input mode
MTR_ImpDemQ_GrO_	Demand Q impulse of external energy meter input of the function has meaning only in impulse input mode
MTR_ImpSupQ_GrO_	Supply Q impulse of external energy meter input of the function has meaning only in impulse input mode

4.3.6.2.2.4. Events

The following events are generated in the event list, as well as sent to the SCADA according to the configuration.

Table 2-4 Generated events of the metering function

EVENT	DIMENSION	EXPLANATION
Demand P	Wh	<i>Demand P value</i>
Supply P	Wh	<i>Supply P value</i>
Demand Q	VArh	<i>Demand Q value</i>
Supply Q	VArh	<i>Supply Q value</i>

4.3.6.2.3. Technical data

Table 2-5 Technical data of the metering function

FUNCTION	RANGE	ACCURACY
Power accuracy	$I > 15\%I_n$	$\pm 3\%$

4.3.6.2.4. Notes for testing

Time period of the accumulation is defined by parameter setting.

Starting accumulation is based on the integrated real-time clock of the device.

For example, for a “Time Interval” setting of 15min, the trigger is: at 0h0min, 0h15min, 0h30min, 0h45 min, 1h0min, etc.

Parameter changing resets the accumulation. Using the settings of the example above, setting new parameters at 0h07min will result in the following:

- the accumulated values are reset to zero,
- the new accumulation starts at 0h15min,
- the first report is sent at 0h30min. Measured values in Events list will also refresh at 0h30min.

4.3.6.2.5. 61850 LN

Instance number of Logical Node is not mentioned in the table below.

Table 2-6 Logical Node and Data Objects of the metering function

LN NAME	DO NAME	DA NAME	FC	EXPLANATION
EMMTR	DmdVArhPV	mag.f	MX	Demand VArh value
		q	MX	quality
		t	MX	timestamp
	DmdWhPV	mag.f	MX	Demand Wh value
		q	MX	quality
		t	MX	timestamp
	SupVArhPV	mag.f	MX	Supply VArh value
		q	MX	quality
		t	MX	timestamp
	SupWhPV	mag.f	MX	Supply Wh value
		q	MX	quality
		t	MX	timestamp

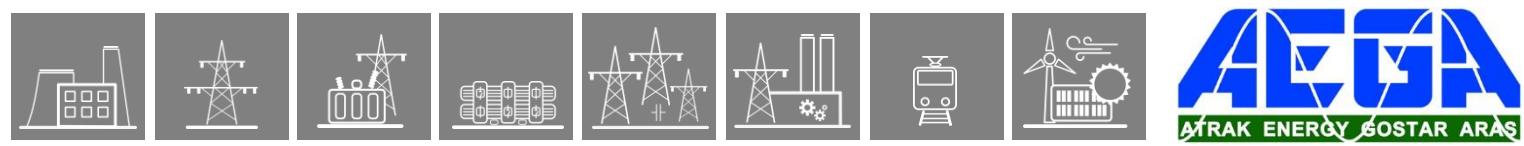

4.3.7. Voltage selection function block

4.3.7.1. Application

In several substation configurations with double busbar, there is no voltage measurement in the bays, but voltage transformers are connected to the busbars only.

If the protection functions configured in the bay devices apply voltage measurement then the correct selection of the voltage sources is needed. The role of the voltage selection is that the protection functions get the voltage of the busbar section to which the feeder or the transformer is connected.

To solve this problem the device gets both three-phase voltages of both busbar sections, and a binary signal decides which one is valid for the protection function.

The “Voltage selection” function block assigns the correct voltages to the protection functions.

4.3.7.2. Mode of operation

The voltage selection is decided by a binary signal. **The conditions are defined by the user applying the graphic equation editor.**

If this input signal is FALSE then the voltages of the voltage input module configured as default input are assigned to the protection functions.

If however this input signal is TRUE then the voltages of the other voltage input module are assigned to the protection functions.

4.3.7.3. The binary status signals

The voltage selection function block has a binary input signal. **The conditions are defined by the user applying the graphic equation editor.**

The **binary input status signal** of the voltage selection function block is shown in Table 1-1.

Binary status signal	Title	Explanation
SelectVolt_USelect_GrO_	USelect	Binary signal controlling the voltage selection

Table 1-1 The binary input status signal of the voltage selection function block

The **binary output status signals** of the voltage selection function block.
The voltage selection function block has no binary output status signals.

4.3.7.4. The parameters

The voltage selection function block has no parameters.

4.3.7.5. The symbol of the function block in the graphic editor

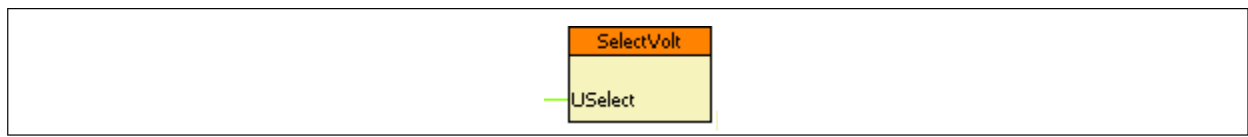

Figure 1-1 The function block of the voltage selection function block

The name of the input signal is a part of the “Binary status signal” name shown in Table 1-1.

4.3.7.6. Example

In this simple example the channel No.1 of the binary input module in position “F” is used as the signal controlling the selection.

If this input signal is FALSE then the voltages of the voltage input module configured as default input are assigned to the protection functions.

If however this input signal is TRUE then the voltages of the other voltage input module are assigned to the protection functions.



Figure 2-1 Example The simple application of the voltage selection function block

4.3.8. Trip Value Recorder

4.3.8.1. Application

For quick evaluating of network faults, it is very useful to see in the event list of the protection device the measured primary analog values (currents, voltages) before and during the fault state. The Trip value recorder function serves this purpose.

This function is not a default element of any configuration, but it can be acquired (please contact Protecta Support team).

4.3.8.1.1. The measurement

The input values of the EuroProt+ devices are the secondary signals of the voltage transformers and those of the current transformers.

These signals are pre-processed by the “Voltage transformer input” function block and by the “Current transformer input” function block. These function blocks are described in separate documents. The pre-processed values include the Fourier basic harmonic phasors of the voltages and currents and the true RMS values. Additionally, it is in these function blocks that parameters are set concerning the voltage ratio of the primary voltage transformers and current ratio of the current transformers.

Based on the pre-processed analogue signals, several function blocks perform additional calculation, e.g.: active and reactive power, frequency, temperature, impedances, higher harmonics, symmetrical components, etc.

The Trip value recorder function calculates the primary values from its three input secondary signals (currents or voltages) and uses them as described in the following chapter.

4.3.8.1.2. Operation principles

The Trip value recorder has two binary inputs: “Start” and “Trip”.

When the “Start” binary input receives a rising edge signal, the function stores the pre-fault value of the three analogue signals and the fault value of the three analogue signal as well and the function starts waiting for the trigger (Trip) signal. If no trigger signal coming and new start signal receives the stored pre-fault and fault values will be overwritten by the latest ones.

The “Trip” binary input of the function is applied for triggering the trip value recording to generate the events with the pre-fault and fault values.

After triggering the function, so the “Trip” binary input is activated, the function generates the following values in the event list and sends them automatically to the SCADA system:

- pre-fault values of the three analog signals 100 ms before the Start signal receives,
- fault values of the three analog signals: average of the values 10 ms and 20 ms after the Start.

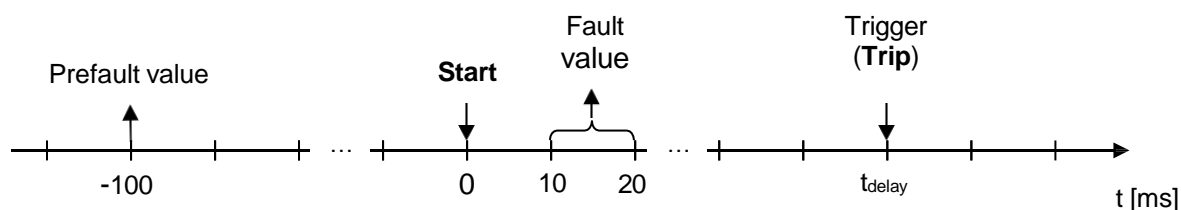

Figure 1-1 Time diagram of the trip recording behaviour

4.3.8.2. Trip value recorder function overview

The graphic appearance of the function block of the trip value recorder function is shown below. The block shows all binary input and output status signals which are applicable in the graphic equation editor.

Usually, the collected general start signal of the protection functions is assigned to the “Start” input and the general trip signal of trip logic function is connected to the “Trip” input.

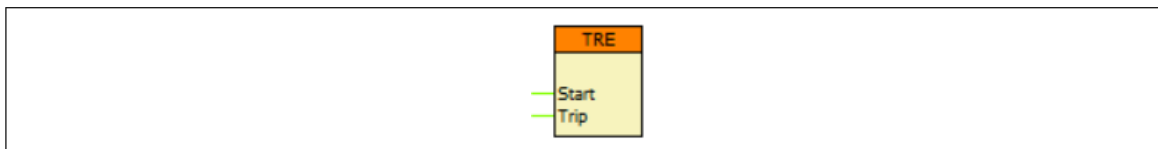

Figure 2-1 Graphic appearance of the function block of the trip value recorder function

4.3.8.2.1. Settings

4.3.8.2.1.1. Parameters

The Trip value recorder function does not have any parameters.

4.3.8.2.2. Function I/O

This section describes briefly the analogue and digital inputs and outputs of the function block.

4.3.8.2.2.1. Analogue inputs

The function uses the sampled values of a current input or voltage input. Moreover, calculated analogue signals i.e.: symmetrical values, differential/bias current values can be used as inputs.

The following table contains the available input channels of the trip value recorder function.

Table 2-1 Available analogue inputs of the trip value recorder function

ANALOGUE INPUTS	RELATED FUNCTION BLOCK
Phase current, phase-to-phase, symmetrical, residual currents	CT4, CalcCurr
Voltage in phase, phase-to-phase, and symmetrical; Reference (busbar) voltages	VT4, CalcVolt
Calculated Idiff/Ibias current of transformer differential protection	DIF87T
Calculated Idiff/Ibias current of busbar differential protection for each bus section	DIF87B

NOTE: Displaying the fault current values of the line differential protection Idiff/Ibias current and the restricted earth fault protection Idiff/Ibias current are integrated into the protection function, thus not need additional trip value functions to display the trip values.

4.3.8.2.2.2. Binary input signals (graphed output statuses)

The conditions of the binary inputs are defined by the user, applying the graphic equation editor (*Logic Editor*). Parts written in **bold** are seen on the left side function block in the Logic editor.

Table 2-2 The binary input signal of the trip value recorder function

BINARY OUTPUT SIGNAL	EXPLANATION
TRE_ Start _GrO_	Dedicated input of the function to receive the start signal of the selected protection functions
TRE_ Trip _GrO_	Dedicated input of the function to receive the trip signal of the selected protection functions

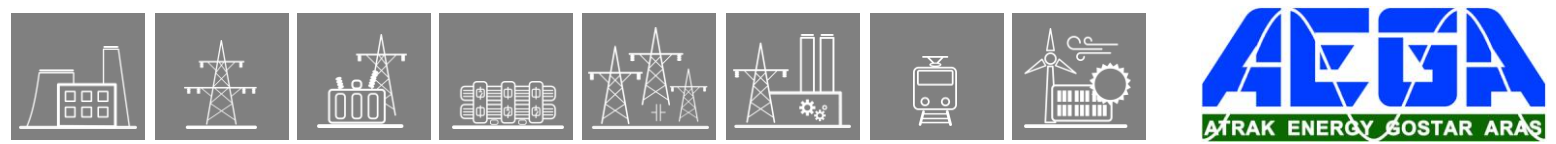

4.3.8.2.2.3. Binary output signals (graphed input statuses)

The Trip value recorder function does not have any binary output signals.

4.3.8.2.2.4. Online data

No default visible values on the *online data* page.

4.3.8.2.2.5. Events

The following events are generated in the event list, as well as sent to the SCADA according to the configuration.

Table 2-3 Generated events of the trip value recorder function

EVENT	VALUE	EXPLANATION
... Prefault*	according to the applied input	Prefault value of the applied signal
... Fault*	according to the applied input	Fault value of the applied signal

**The event text may vary according to the actual device configuration (.epcs)*

4.3.9. RTD temperature input function

4.3.9.1. Application of the RTD input

If the factory configuration includes an RTD temperature input hardware module, the temperature input function block is automatically configured among the software function blocks. Separate temperature input function blocks are assigned to each temperature input hardware module.

The RTD+1100 temperature input hardware module is equipped with four special input channels, the RTD+ 0200 has a single channel only. (See EuroProt+ hardware description document.) To each channel, a temperature sensor can be connected. The temperature is measured as the resistance value of the sensor, which depends upon the temperature.

The sensors can be connected by wiring methods, shown in Figure 1–1, Figure 1–2 and Figure 1–3. The connection mode is identified also by parameter setting.

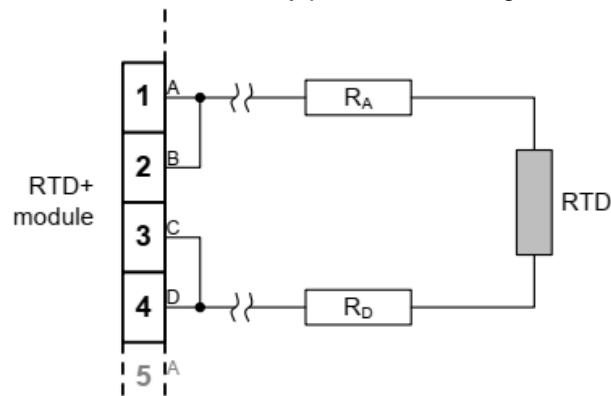

Figure 1–1 2-wire RTD wiring

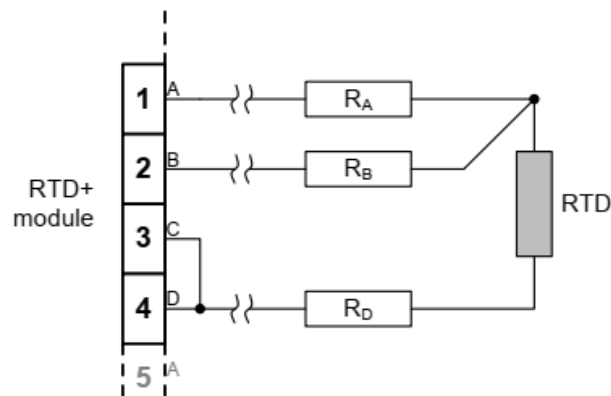

Figure 1–2 3-wire RTD wiring

When 3-wire connection is applied, it is supposed that $R_A=R_D$.

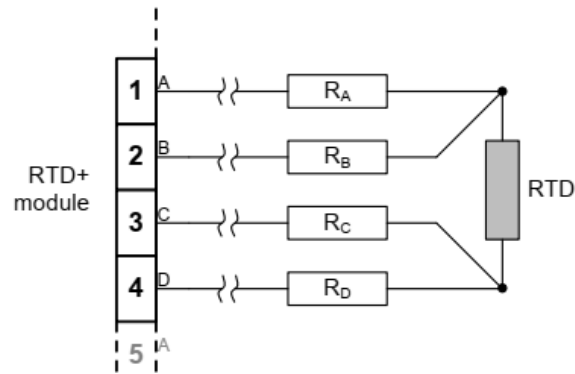
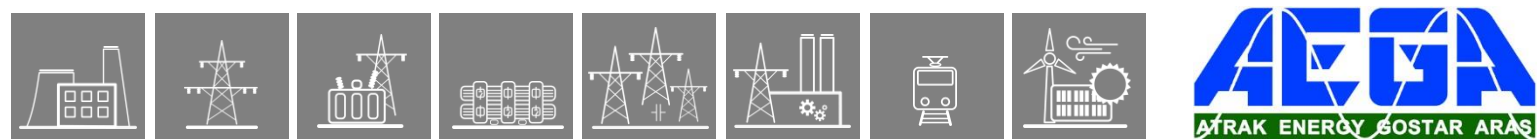

Figure 1-3 4-wire RTD wiring

The channels of the module is independent of each other. To each channel a dedicated measuring module is assigned. These measuring modules are described in a separate document: “**GGIORTD temperature measurement module function block description**”. The module is prepared to connect the following types of sensors:

- Pt100/Ni100
- Ni120/Ni120US
- Pt250/Ni250
- Pt1000/Ni1000
- Cu10
- Service-Ohm (60 Ω ... 1.6 k Ω)

The applied type of sensors define the conversion mode from measured resistance to temperature. These are selected by parameters of the temperature measuring module. See separate document: “**GGIORTD temperature measurement module function block description**”.



4.4. Disturbance recorder function

The disturbance recorder function can record analog signals and binary status signals. These signals are configured using the EuroCAP software tool.

The disturbance recorder function has a binary input signal, which serves the purpose of starting the function. **The conditions of starting are defined by the user, applying the graphic equation editor.** The disturbance recorder function keeps on recording during the active state of this signal but the total recording time is limited by the timer parameter setting.

The pre-fault time, max recording time and post-fault time can be defined by parameters.

4.4.1. Mode of recording

If the triggering conditions defined by the user - using the graphic equation editor – are satisfied and the function is enabled by parameter setting, then the disturbance recorder starts recording the sampled values of configured analog signals and binary signals.

The analog signals can be sampled values (voltages and currents) received via input modules or they can be calculated analog values (such as negative sequence components, etc.)

The number of the configured binary signals for recording is limited to 64, and up to 32 analog channels can be recorded.

The available memory for disturbance records is 12 MB.

There are two function blocks available. The first function (**DRE**) applies 20 sampling in a network period. Accordingly for 50 Hz, the sampling frequency is 1 kHz. (For 60 Hz the sampling frequency is 1.2 kHz). This is used in all configurations by default.

The second function (**DRE2**) is capable to be set by parameter to apply 20 or 40 sampling in a network period. This way accordingly for 50 Hz, the sampling frequency is 1 kHz or 2 kHz (and for 60 Hz the sampling frequency is 1.2 kHz or 2.4 kHz). *Except for this, the two function blocks are the same.*

As an example, for 50 Hz, if the duration of the record is 1000 ms then one analog channel needs about 7 kB and a binary channel needs 2 kB, Using the following formula the memory size can be estimated:

$$\text{Memory size of a record} = (n \cdot 7 \text{ kB} + m \cdot 2 \text{ kB}) \cdot \text{record duration (s)}$$

Here n,m: are the number of analog and binary channels respectively.

During the operation of the function, the pre-fault signals are preserved for the time duration as defined by the parameter “PreFault”.

The recording duration is limited by the parameter “Max Recording Time” but if the triggering signal resets earlier, this section is shorter.

The post-fault signals are preserved for the time duration as defined by the parameter “PostFault”.

During or after the running of the recording, the triggering condition must be reset for a new recording procedure to start.

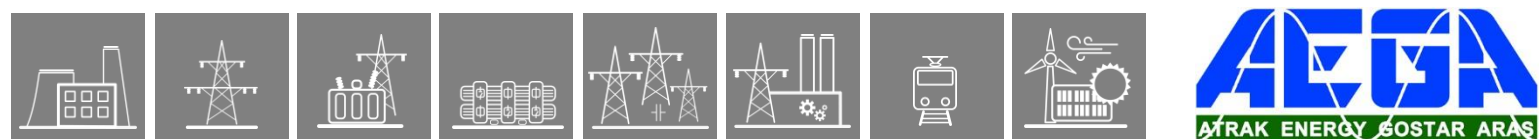

4.4.2. Format of recording

The records are stored in standard COMTRADE format.

- The configuration is defined by the file .cfg,
- The data are stored in the file .dat,
- Plain text comments can be written in the file .inf.

4.4.3. Downloading and evaluating the disturbance records

The procedure for downloading the records is described in detail in the EuroProt+ manual “Remote user interface description”, Chapter 4.7. The three files are zipped in a file .zip. This procedure assures that the three component files (.cfg, .dat and .inf) are stored in the same location.

The evaluation can be performed using any COMTRADE evaluator software. Protecta offers the “**srEval**” software for this purpose. The application of this software is described in detail in the “srEval manual”. This manual can be downloaded from the following Internet address: http://www.softreal.hu/product/sreval_en.shtml.

4.4.4. Parameters of the disturbance recorder functions

Enumerated parameters

Parameter name	Title	Selection range	Default
Parameter for activation			
DRE_Oper_EPar_	Operation	Off, On	Off
DRE_Resolution_EPar_	Resolution *	1/1.2kHz, 2/2.4kHz	1/1.2kHz

*only on the optional 2/2.4 kHz disturbance recorder function

Table 1-1 The enumerated parameters of the disturbance recorder functions

Timer parameters

Parameter name	Title	Unit	Min	Max	Step	Default
Pre-fault time:						
DRE_PreFault_TPar_	PreFault	msec	100	1000	1	200
Post-fault time:						
DRE_PostFault_TPar_	PostFault	msec	100	1000	1	200
Overall-fault time limit:						
DRE_MaxFault_TPar_	Max Recording Time	msec	500	10000	1	1000

Table 1-2 The timer parameters of the disturbance recorder functions

NOTE: The device goes automatically in “Warning” state and sends a warning message (see [Figure 1-1](#)) if the sum of the pre-fault time and post-fault time is longer than the overall-fault time. The corresponding message in the RDSP log file is: „Wrong DR settings. PreFault + PostFault must be less than MaxFault. Check the parameters.”

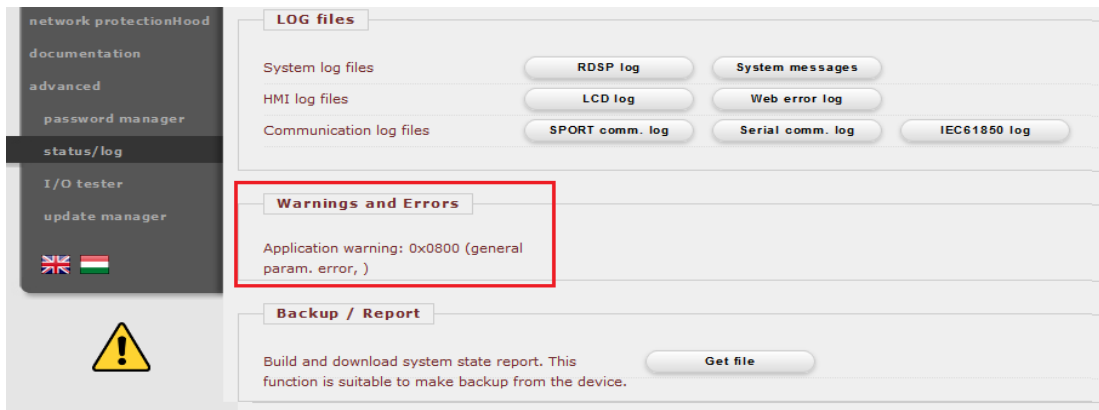

Figure 1-1 Warning message if the settings are invalid

4.4.5. The input signals of the disturbance recorder functions

Binary status signals

The disturbance recorder function has a binary input signal, which serves the purpose of starting the function. **The conditions of starting are defined by the user, applying the graphic equation editor.**

Binary status signal	Explanation
DRE_Start_GrO_	Output status of a graphic equation defined by the user to start the disturbance recorder function.

Table 1-3 The binary input signal of the disturbance recorder functions

The recording is performed if the function is enabled by the parameter setting AND the triggering condition as defined by the user is “True” as well.

4.4.6. The function blocks

The two function blocks of the disturbance recorder function is shown in [Figure 1-2](#). The block shows the binary input status signal, which serves the purpose of triggering the record. It is defined by the user in the graphic equation editor.

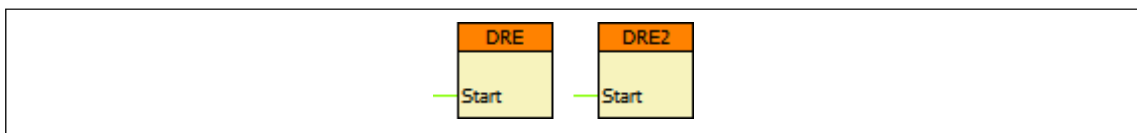
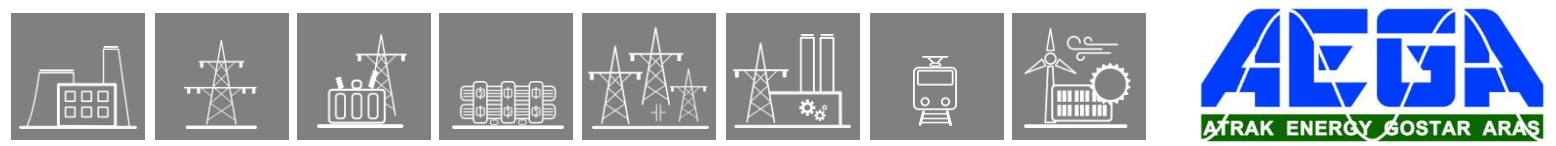

Figure 1-2 The function blocks of the disturbance recorder functions

4.4.7. The recorded signals

The analog and binary signals to be recorded are configured using the EuroCAP software tool in the menu item “Software configuration/Disturbance recorder”. (The access level of the user must be at least “Master”.) The application of this software is described in detail in the EuroCAP manual.



4.5. Event recorder

The events of the device and those of the protection functions are recorded with a time stamp of 1 ms time resolution. This information with indication of the generating function can be checked on the touch-screen of the device in the “Events” page, or using an Internet browser of a connected computer

4.6. Setting of distance protection function

4.6.1. Setting the polygon characteristics

4.6.1.1. Impedance characteristics of the distance protection

The distance protection function calculates the positive sequence impedance in six measuring loops. The calculated R_1 and $X_1 = \omega L_1$ co-ordinate values define six points on the complex impedance plane. The protection function compares these points with the „polygon” characteristics of the distance protection, shown in Figure 1-1.

The main setting values of “Zone R” and “Zone X” refer to the positive sequence impedance of the fault loop. The resistance value includes the positive sequence fault resistance of the possible electric arc and, in case of a ground fault, the positive sequence resistance of the tower grounding as well.

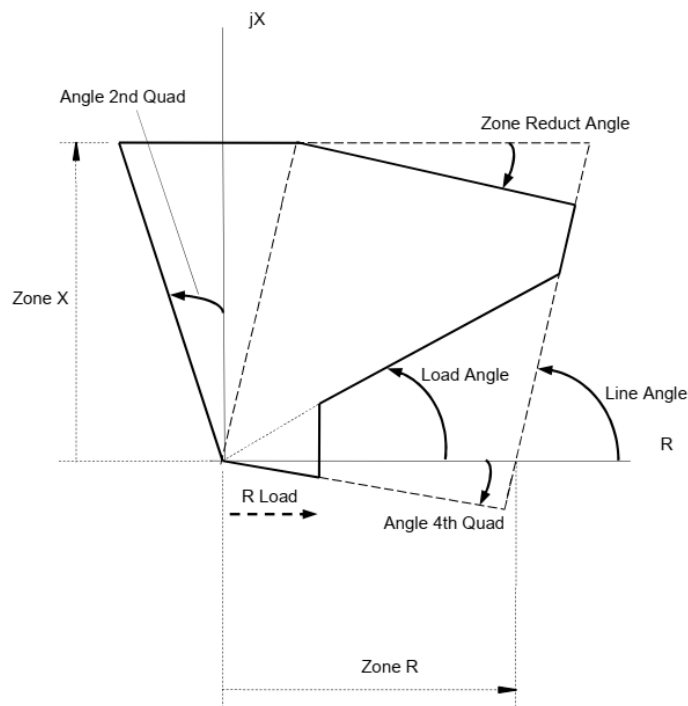

Figure 1-1 The polygon characteristics of the distance protection function on the complex plane (Example: Zone1)

If a measured impedance point is inside the polygon, shown in Figure 1-1, then the algorithm generates the true value of the related output binary signal.

The distance protection has six zones applying polygon characteristics, each of them have independent parameter setting values.

C

4.6.1.2. The parameters

The parameters needed in the polygon evaluation procedure of the distance protection function are explained in the following tables.

Enumerated parameters

The enumerated parameters of the zones (according to Table 1-1) serve disabling of the zones one-by-one, or setting the direction:

- “Forward” (the orientation of the polygon is according to Figure 1-1),
- “Backward” (the orientation of the polygon is according to Figure 1-2),
- “NonDirectional” (the extended polygon is according to Figure 1-3),

NOTE: Zone 1 cannot be “NonDirectional”. It is the free user’s choice to select the required directionality.

Parameter name	Title	Selection range	Default
Parameters to select directionality of the individual zones:			
DIS21_Z1_EPar_	Operation Zone1	Off, Forward, Backward	Forward
DIS21_Z2_EPar_	Operation Zone2	Off, Forward, Backward, NonDirectional	Forward
DIS21_Z3_EPar_	Operation Zone3	Off, Forward, Backward, NonDirectional	Forward
DIS21_Z4_EPar_	Operation Zone4	Off, Forward, Backward, NonDirectional	Forward
DIS21_Z5_EPar_	Operation Zone5	Off, Forward, Backward, NonDirectional	Backward

Table 1-1 Enumerated parameters for the POLY logic

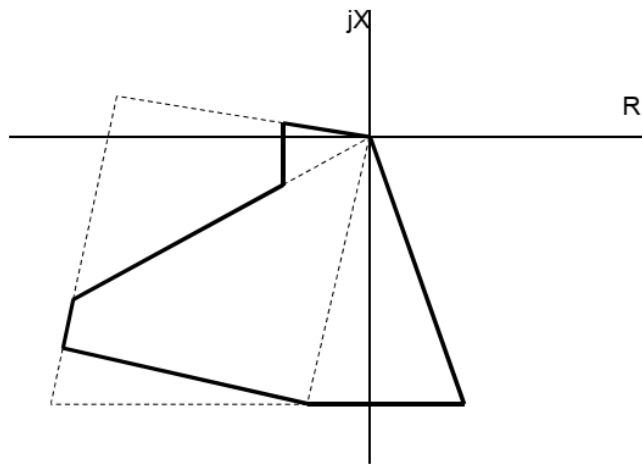

Figure 1-2 The polygon characteristics of the distance protection function with “Backward” setting (Example Zone1)

C

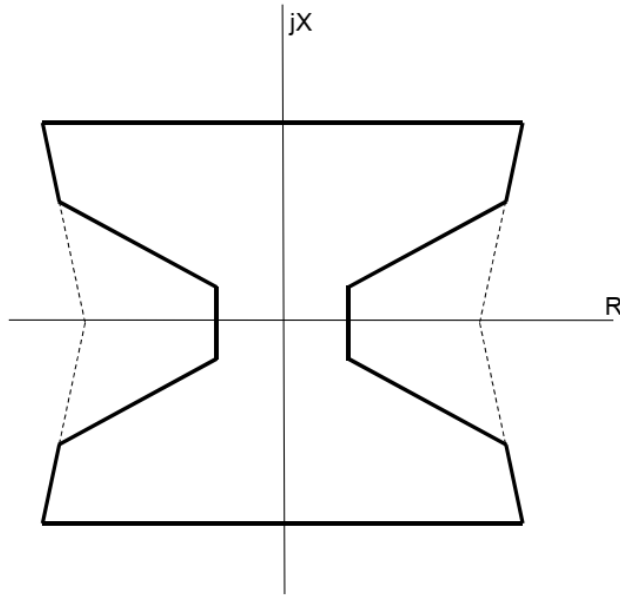

Figure 1-3 The polygon characteristics of the distance protection function Zones 2-5 with “NonDirctional” setting

Boolean parameters for the individual zones are listed in Table 1-2. These parameters define if the operation of the function in the zones generate trip command (0) or indicate starting only (1). The usual setting is the default; the faults detected in the individual zones generate also a trip command. For special applications, the trip command can be blocked.

Note: if also the start signals need to be blocked the switch the selected “Operation” parameters (Table 1-1) to “Off”.

Parameter name	Title	Default	Explanation
DIS21_Z1St_BPar_	Zone1 Start Only	0	0 for Zone1 to generate trip command
DIS21_Z2St_BPar_	Zone2 Start Only	0	0 for Zone2 to generate trip command
DIS21_Z3St_BPar_	Zone3 Start Only	0	0 for Zone3 to generate trip command
DIS21_Z4St_BPar_	Zone4 Start Only	0	0 for Zone4 to generate trip command
DIS21_Z5St_BPar_	Zone5 Start Only	0	0 for Zone5 to generate trip command

Table 1-2 Boolean parameters of the phase selection logic

C

Floating point parameters

The floating point parameters of the zones (according to Table 1-3) serve setting the main sizes of the polygons for the zones one-by-one. See Figure 1-1.

These parameters can be calculated if the parameters of the protected lines or cables are known. The calculation methods are demonstrated in Appendix 1.

Parameter name	Title	Dim.	Min	Max	Default
R and X setting values for the five zones individually:					
DIS21_Z1R_FPar	Zone1 R	ohm	0.1	200	10
DIS21_Z2R_FPar	Zone2 R	ohm	0.1	200	10
DIS21_Z3R_FPar	Zone3 R	ohm	0.1	200	10
DIS21_Z4R_FPar	Zone4 R	ohm	0.1	200	10
DIS21_Z5R_FPar	Zone5 R	ohm	0.1	200	10
DIS21_Z1X_FPar	Zone1 X	ohm	0.1	200	10
DIS21_Z2X_FPar	Zone2 X	ohm	0.1	200	10
DIS21_Z3X_FPar	Zone3 X	ohm	0.1	200	10
DIS21_Z4X_FPar	Zone4 X	ohm	0.1	200	10
DIS21_Z5X_FPar	Zone5 X	ohm	0.1	200	10
Load encroachment setting:					
DIS21_LdR_FPar	R Load	ohm	0.1	200	10
Zero sequence current compensation factors for the five zones individually:					
DIS21_Z1aX_FPar_	Zone1 (Xo-X1)/3X1		0	5	1
DIS21_Z1aR_FPar_	Zone1 (Ro-R1)/3R1		0	5	1
DIS21_Z2aX_FPar_	Zone2 (Xo-X1)/3X1		0	5	1
DIS21_Z2aR_FPar_	Zone2 (Ro-R1)/3R1		0	5	1
DIS21_Z3aX_FPar_	Zone3 (Xo-X1)/3X1		0	5	1
DIS21_Z3aR_FPar_	Zone3 (Ro-R1)/3R1		0	5	1
DIS21_Z4aX_FPar_	Zone4 (Xo-X1)/3X1		0	5	1
DIS21_Z4aR_FPar_	Zone4 (Ro-R1)/3R1		0	5	1
DIS21_Z5aX_FPar_	Zone5 (Xo-X1)/3X1		0	5	1
DIS21_Z5aR_FPar_	Zone5 (Ro-R1)/3R1		0	5	1
Parallel line coupling factor:					
DIS21_a2X_FPar_	Par Line Xm/3X1		0	5	0
DIS21_a2R_FPar_	Par Line Rm/3R1		0	5	0
Data of the protected line for displaying distance:					
DIS21_Lgth_FPar_	Line Length	km	0.1	1000	100
DIS21_LReact_FPar_	Line Reactance	ohm	0.1	200	10

Table 1-3 Floating point parameters for the distance protection

Integer parameters

The integer parameters in * "Zone Reduct Angle" parameter is valid for Zone 1 only

Table 1-4 show the "fine-tuning" parameters of the polygon characteristics. For explanation, see Figure 1-1.

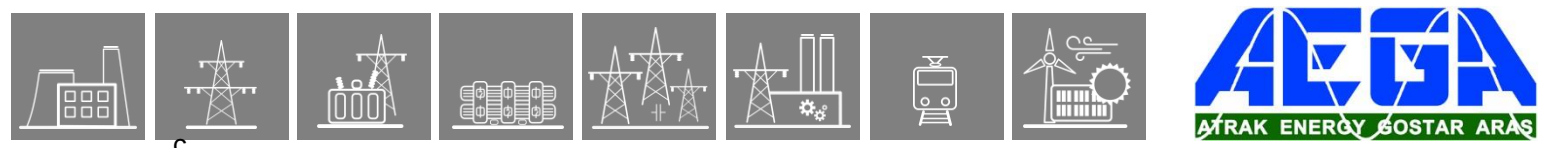

C

Example for setting the first impedance stage:

For the setting procedure, the following data are necessary:

Data:

120 kV overhead line,

Line length: length = 40 km

Per unit positive sequence reactance: $x1 = 0.41 \Omega/\text{km}$

Per unit positive sequence resistance: $r1 = 0.12 \Omega/\text{km}$

Per unit zero sequence reactance: $x0 = 1.03 \Omega/\text{km}$

Per unit zero sequence resistance: $ro = 0.30 \Omega/\text{km}$

Voltage transformer turns ratio: $au = 120 \text{ kV}/0.1 \text{ kV}$

Current transformer turns ratio: $ai = 600 \text{ A} / 5 \text{ A}$

Calculation:

Zone1 X [Ohm]

Setting of the reactance is calculated according to the „classical” setting formula:

$$X^I \leq \frac{X_{Line}}{(1 + \varepsilon)}$$

The parameter values are to be given in secondary Ohm units.

The primary reactance to be set:

$$X_{prim.} = \text{length} * x1 / (1 + \varepsilon) = 40\text{km} * 0.41 \Omega/\text{km} / (1 + 0.15) = 14.26 \Omega$$

Transformed to secondary value:

$$X_{second.} = ai/au * X_{prim.} = (600/5) / (120/0.1) * 14.26 \Omega = 1.426 \Omega$$

The value to be set:

$$\underline{\text{Zone1 X}} = X_{second.} = \underline{1.426 \Omega}$$

Zone1 R [Ohm]

When setting the resistance, the following considerations must be made:

The resistance value of the line section to be protected, calculated with the factor $1/(1 + \varepsilon)$ must be within the polygon.

In case of electric arc at the fault location, which is approximated with a resistance value added to the impedance of the line section. This increases the total resistance value, which must be within the polygon too. Remember Warrington formula for calculation the arc resistance caused by I RMS current and d arc length:

$$R_{arc} [\Omega] = \frac{28700 * d^{[m]}}{I^{[A]1.4}}$$

For example $d = 1 \text{ m}$ and $I = 500 \text{ A}$ $R_{arc} = 4.78 \Omega$. If $I = 1000 \text{ A}$, this value decreases to 1.81Ω (primary value).

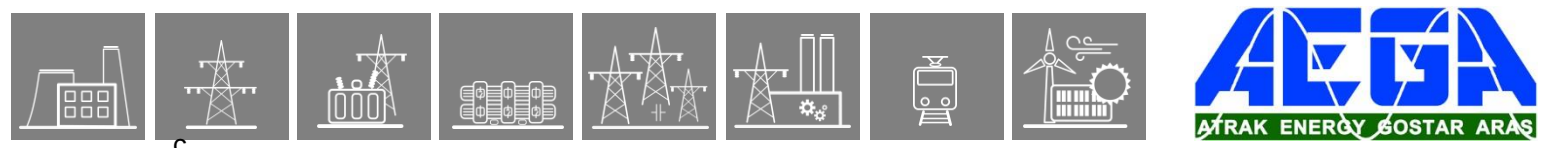

C

In case of earth fault, the earth resistance at the fault location must be taken into consideration. If the steel towers are interconnected with each other with the earth wire, this resistance can be small. The sum of the mentioned resistance (line resistance + arc + earth resistance) must be within the polygon.

The calculated impedance contains errors because of the inaccuracy of the algorithm, the amplitude and phase errors of the VT-s and CT-s, the measuring errors caused by the short-circuit transients. The sequence of calculated impedances is not a single point on the impedance plane, but they will cover a certain area. The characteristics must be set to include this area as well.

The power supply from the far end of the protected line distorts the measured resistance (magnitude and also phase angle).

Because of the mentioned effects, the characteristics must be widened in R direction.

The following facts however contradict this requirement:

The role of the R setting is to exclude the calculated impedance in case of high load of the line. The small "normal" impedance during heavy load is not allowed to start the protection. See the setting of the load by "R Load" and "Load Angle", explained below.

The unwanted operation during power swings (without fault on the protected line) has to be avoided if possible. See the power swing setting explained below.

In case of a fault during heavy load, the impedance calculated for the healthy phase(s) approaches the borders of the characteristics. The phase-selectivity requires a proper R setting value, which excludes these impedance values.

Because of the contradiction of the requirements, an engineering compromise has to be applied: the setting must be selected based on experiences.

For example in case of a 120 kV transmission line, the compromise

Zone 1 R=Zone1 X can be an adequate setting. The primary value 14.26 Ω can include the

- 40 km*0.056 Ω /km /(1+0.15)= 1.95 Ω resistance of the line,
- arc resistance,
- earth resistance as well.

If needed, this value can be corrected according to the experience.

The value of parameter Zone 1R is the same as that of parameter Zone 1X, secondary values.

$$\underline{\text{Zone1 R}} = \underline{\text{Zone1 X}} = \underline{1.426 \Omega}$$

Line Angle

The influence of this parameter is to set the slope of the rightmost line of the impedance characteristic as it is shown in Figure 1-1. Usually it is set according to the given data of the protected line

$$\text{Line Angle} = \text{ArcTan} (x1/r1)$$

Using the data given for the 120 kV line:

per unit positive sequence resistance: 0.12 Ω/km

per unit positive sequence reactance: 0.41 Ω/km

$$\text{Line Angle} = \text{ArcTan} (0.41/0.12) = 73.69^\circ$$

The setting:

$$\underline{\text{Line Angle}} = \underline{73^\circ}$$

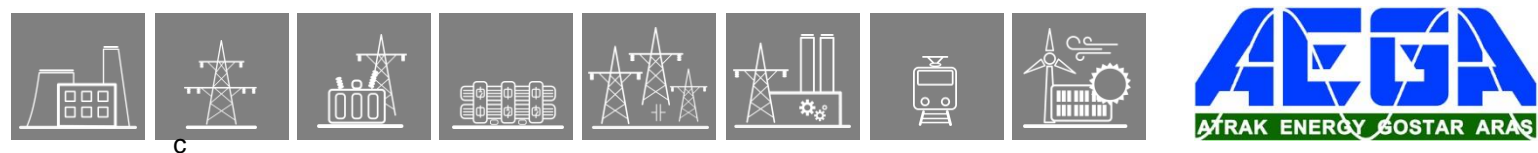

C

NOTE1: The line angle intersects the point of the horizontal line of the distance protection (See “Zone1 X” setting) where the “Zone Reduction Angle” parameter starts to modify the shape of the characteristic. Related to the setting of the parameter “Zone Reduction Angle” see the consideration in Appendix below.

NOTE2: To cover better the increased measured resistance in case of faults near to the far line end this parameter can also be set to a lower value.

Angle 4th Quad

Slope of the characteristics border line $\alpha = \arctg(|X|/R)$ in the negative reactance area (see Figure 1-1).

When setting this parameter the following considerations are to be made:

The principal border of the possible impedance area is the R axis since negative reactance is not possible in case of fault on the line. The impedance is on the R axis, when the fault is exactly at the current transformer, and the fault resistance is measured. The characteristics with safety margin must include this measured point.

The power supply from the far end of the line can distort the voltage of the fault resistance. The impedance is calculated with the measured I_R current and the U_R voltage at the relay location. The U_R voltage includes the voltage drop on the fault resistance too. If before the fault, there was a heavy power transfer on the line, this voltage drop caused by the far-end equivalent voltage source has a different vector position, than the voltage drop caused by the voltage source at the relay location. The voltage on the resistance can have a considerable phase shift. In case of unfavorable direction, it can turn the measured impedance point out of the characteristics. The protection against this effect is the “opening” of the inclination of the characteristics.

In case of a close-in-fault, the voltage can have a very small value, which cannot be sufficient when calculating the fault direction. In this case, the voltage values stored in the memory are applied to calculate the direction. During a fault, the power flow can change largely, as compared to the flow during normal operation of the network, and the voltage during a fault is phase-shifted as compared to the healthy voltage. This phase shift depends on the impedance and on the power flow. To decide a correct direction, it is useful to “open” the inclination of the characteristic line.

Due to the inaccuracy of the algorithm, the measuring errors caused by the short-circuit transients and the angle error of the measuring transformers the impedance contains inaccuracy, too. In this way, the calculated impedance does not determine a single point on the impedance plane, but several points, which can cover a rather large area in the subsequent sampling sequence. The characteristics must include this area as well. Because of the effects mentioned above it is useful to open the characteristics.

The following fact however contradicts the opening:

The characteristics must exclude the impedance measured in the healthy loops. The separation of the measuring loops based on the zero sequence current can exclude the measured impedance values of some loops, but the remaining impedance values measured in healthy loops can approach the characteristics, especially in case of heavy pre-fault load. An example is a close-in single phase-to-earth fault in phase „A”, when the impedance measured in the healthy loop “B” is close to the border of the characteristics. Therefore, it is useful to set the characteristics as closed as possible.

The requirements are in contradiction, an engineering compromise is needed to set the slope based on the experience. When making these considerations the mentioned VECTOR program of PROTECTA can help identifying the critical situations, and investigating the effect of the actual parameters as well.

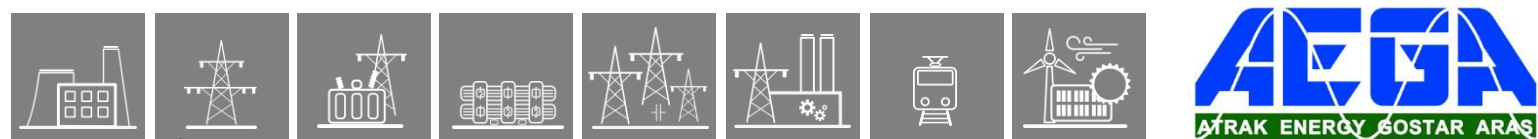

C

This parameter can be calculated as

$$\text{Angle 4th Quad} = \text{ArcTan} (|X|/R) \text{ [deg]}$$

Here the ratio defines the slope only; X and R have no relationship to the positive sequence impedance data of the line. The unit of this parameter is degrees.

For example, in case of a 120 kV transmission line the proposed setting value is Angle 4th Quad = 15 deg. The greatest possible opening is 30 deg. If needed, this setting can be modified.

The proposed setting:

$$\text{Angle 4th Quad} = 15 \text{ deg}$$

This angle is common for all five zones.

Angle 2nd Quad

Slope of the characteristics border line $\beta = \text{arctg}(|R|/X)$ in the negative resistance area (see Figure 1-1).

When setting this parameter, similarly to the setting of the slope "Angle 4th Quad," the following considerations are to be made:

The principal border of the possible impedance values is the impedance of the line. The points of this line are measured in case of solid faults along the line. The characteristics must include these points.

In case of close in faults, the voltage will be a very small value, which cannot be sufficient when calculating the fault direction. In this case, the voltage values stored in the memory are to be applied to calculate the direction. During a fault, the power flow can change largely, as compared to the flow during normal operation of the network, and the voltage during fault is rotated, as compared to the healthy voltage. This phase shift depends on the impedances and on the power flow. To decide a correct direction, it is useful to "open" the inclination of the characteristic line.

Due to the inaccuracy of the algorithm, the measuring errors caused by the short-circuit transients and the angle error of the measuring transformers, the impedance contains inaccuracy too. In this way, the calculated impedance does not determine a single point on the impedance plane, but points, which can cover a rather large area in the subsequent sampling sequence. The characteristics must include this area as well. Because of the effects mentioned above it is useful to open the characteristics.

The following fact however contradicts to the opening:

The characteristics must exclude the impedance measured in the healthy loops. The separation of the measuring loops based on the zero sequence current can exclude the measured impedance values of some loops, but the remaining impedance values measured in healthy loops can approach the characteristics, especially in case of heavy pre-fault load. An example is a close-in double phase fault, in phases „B” and „C”, when the impedance measured in the healthy loop „AB” is close to the borders of the characteristics. Therefore, it is useful to set the characteristics as closed as possible.

The requirements are in contradiction, an engineering compromise is needed to set the slope based on the experiences. When making these considerations the mentioned VECTOR program of PROTECTA can help identifying the critical situations, and investigating the effect of the actual parameters as well.

This parameter can be calculated as

$$\text{Angle 2nd Quad} = \text{ArcTan} (|R|/X) \text{ [deg]}$$

Here the ratio defines the slope only; X and R have no relationship to the positive sequence impedance data of the line. The unit of this parameter is degrees.

For example in case of a 120 kV transmission line the proposed setting is: Angle 2nd Quad = 15 deg. This is the inclination from the X axis 15 deg to the left. The greatest possible opening is 30 deg. If needed, this setting can be modified.

The proposed setting:

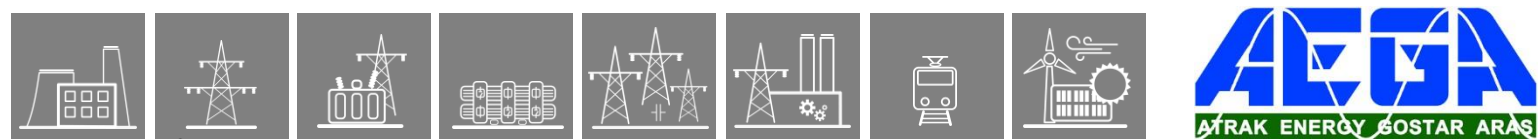

C

Angle 2nd Quad = 15 deg

This angle is common for all five zones.

R Load Load Angle

When setting the impedance stages it has to be taken into account that the setting should be well below the impedance measured in maximum power operating condition. If however extremely high (temporary) load can be expected and at the same time the zone reach in R direction is set to a high value then the “load encroachment” property of the distance protection function can help in case of high load, to exclude the measured impedance from the distance characteristic. There are two parameters to serve tightening the characteristic: „R Load“ and „Load Angle“. The effect of these parameters is shown in Figure 1-1. The application of these parameters supposes that the power transfer along the line is mostly active power only. Based on the supposed maximum current (or thermal load limit) in overload operation the load resistance can be calculated

$$R_{load} = \frac{U_{line-to-line,rated}}{\sqrt{3} * I_{oper,max}} = \frac{(U_{line-to-line,rated})^2}{S_{oper,max}}$$

where

$I_{oper,max}$ is the highest possible (overload) current;
 $S_{oper,max}$ is the thermal load limit, three-phase power.

This consideration is especially important in high voltage systems. For the 120 kV example above, the thermal load limit of the line is:

$S_{oper,max} = 110 \text{ MVA}$

The calculated resistance in case of max load is:

$$R_{load} = \frac{(U_{line-to-line,rated})^2}{S_{oper,max}} = \frac{(120kV)^2}{110MVA} = 130\Omega \text{ (primary value).}$$

As compared with the proposed “Zone 1 R” setting = 14.26 Ω this results

130 Ω / 14.26 Ω \cong 9 - times margin. Consequently, in case of a relatively long 120 kV line, the load has no influence on the setting of the characteristic parameters.

This primary resistance 130 Ω is to be calculated to the secondary side of the measuring transformers.

$R_{load \text{ second.}} = ai/au * R_{load \text{ prim.}} = (600/5) / (120/0.1) * 130 \Omega = 13 \Omega$

This setting may influence the shape of the characteristic in higher zones and the shape of the characteristic for power swing detection.

For a 200 km long 400 kV line however the proposed setting is:

Zone 1 R = Zone 1 X = 200 km * 0.32 Ω /km / (1+0.15) = 55.65 Ω

$$R_{load} = \frac{(U_{line-to-line,rated})^2}{S_{oper,max}} = \frac{(400kV)^2}{1200MVA} = 133\Omega \text{ (primary value).}$$

133 Ω / 55.65 Ω \cong 2.3 - times margin. If large “Zone 1 R” setting value is needed due to the measurement distortion of the fault resistance, then the load resistance can be within the extended characteristic. Consequently, the correct “R load” setting is important.

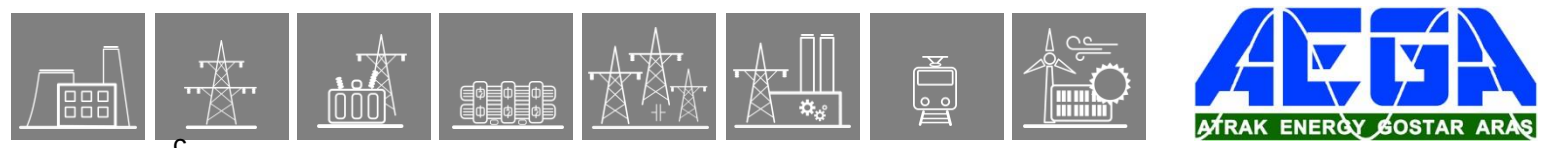

C

This primary resistance 133Ω is to be calculated to the secondary side of the measuring transformers.

If at the relay location also a relatively small amount of reactive power is measured then load encroachment area is "opened" using the „Load Angle“ parameter. The method of calculation is as an example with 20% reactive load:

$$\text{Load Angle} = \text{ArcTan}(Q_{\text{max}}/P_{\text{max}}) = \text{ArcTan}(0.20) = 11.3 \text{ deg} \cong \underline{12 \text{ deg}}$$

Zone Reduction Angle

The algorithm of the distance protection calculates fault distance based on the measured reactance value.

If the fault resistance at the fault location cannot be neglected and before fault inception there is considerable power transfer on the protected line the calculated reactance value – consequently the calculated distance to fault - is distorted. This distortion means overreaching (or under-reaching) of the distance protection. Overreaching can result operation also in case of fault outside the protected zone, resulting unselective tripping.

To compensate this distortion of the measured distance the X border line of the polygon-shaped characteristic can be tilted downwards or upwards, depending on the amount and direction of the pre-fault power transfer on the protected line. Figure 1-1 shows tilting downwards, the zone reduction angle is clockwise.

The tilting is performed dynamically in five sections depending on the extent of the pre-fault power transfer. The setting of the tilting angle needs technical consideration. This method of calculation is explained in the Appendix.

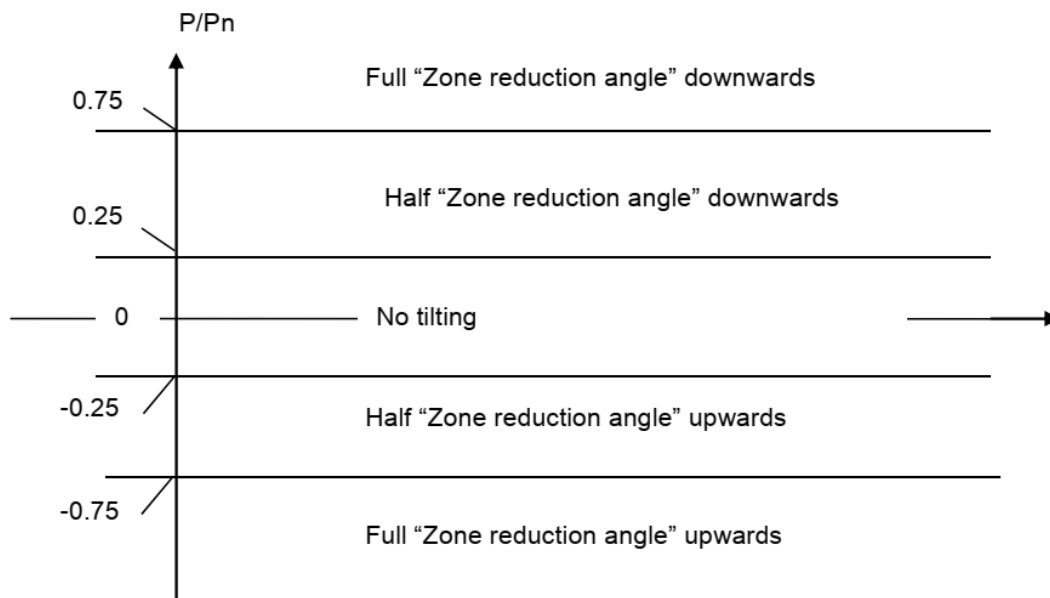

Figure 1-4 Dynamic sections of the "Zone reduction"

The result of this correction is that for fault at the zone reach point, the behavior of the distance protection is practically independent on the pre-fault load state of the protected line or cable.



C

Zone1 (Xo-X1)/3X1
Zone1 (Ro-R1)/3R1

In case of faults involving the ground, the algorithm applies formulas for the impedance (distance) calculation, where the phase currents are compensated with the zero sequence current.

$$Z = \frac{U_{phase}}{I_{phase} + \alpha \cdot 3I_0}$$

The α zero sequence current compensation factor is applied in the algorithm of the distance protection function in the form of two real factors. Both of them are calculated from the data of the protected line. With the data given above for the 120 kV line:

$$\alpha_x = \frac{(x_0 - x_1)}{3 \cdot x_1} = \frac{(1.03 - 0.41)}{3 \cdot 0.41} = 0.504$$

$$\alpha_r = \frac{(r_0 - r_1)}{3 \cdot r_1} = \frac{(0.3 - 0.12)}{3 \cdot 0.12} = 0.5$$

Accordingly the required setting values are:

Zone1 (Xo-X1)/3X1 = 0.5
 Zone1 (Ro-R1)/3R1 = 0.5

Note: In some applications the parameters “Zone2 (Xo-X1)/3X1” and “Zone2 (Ro-R1)/3R1” is considered to be equal to those of the Zone1. In this case, this parameter cannot be seen in the group of parameters for the second zone.

Par Line Xm/3X1
Par Line Rm/3R1

In case of asymmetrical fault involving the ground, the zero sequence current of the parallel line influences the impedance measurement. To compensate this effect the zero sequence current of the parallel line is to be measured, and the effect is compensated in the calculation using the zero sequence mutual compensation factors for the parallel line. In the applied algorithm, it is performed in the form of two real factors:

$$\beta_r = \frac{r_m}{3 \cdot r_1}$$

$$\beta_x = \frac{x_m}{3 \cdot x_1}$$

Additionally to the given positive sequence reactance and resistance (See the data of the example above):

per unit positive sequence reactance: $x_1 = 0.41 \Omega/\text{km}$
 per unit positive sequence resistance: $r_1 = 0.12 \Omega/\text{km}$

the data of the mutual per unit impedances are also needed. In this example, they are supposed to be:

per unit mutual zero sequence reactance: $x_m = 0.70 \Omega/\text{km}$
 per unit mutual zero sequence resistance: $r_m = 0.15 \Omega/\text{km}$

With these data:

$$\frac{r_m}{3 \cdot r_1} = \frac{0.15}{3 \cdot 0.12} = 0.42$$

$$\frac{x_m}{3 \cdot x_1} = \frac{0.70}{3 \cdot 0.41} = 0.57$$

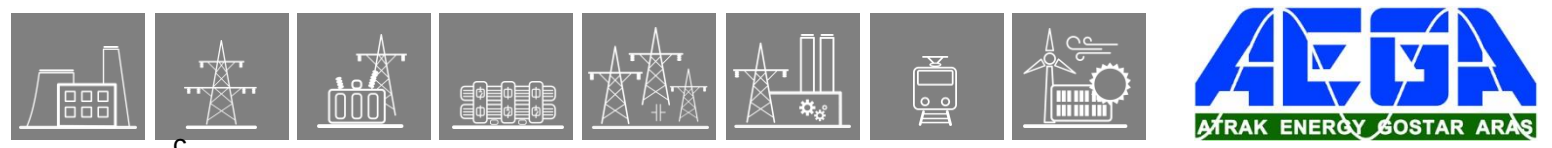

C

Accordingly the required setting values are:

$$\underline{\text{Par Line } X_m/3X1 = 0.57}$$

$$\underline{\text{Par Line } R_m/3R1 = 0.42}$$

This compensation factor is considered for Zone 1 only.

Zone1 Time Delay

The first stage of the distance protection can be delayed.

The time delay of the first stage is to be set with this parameter in milliseconds. The usual setting is 0, which means no additional time delay; the protection function operates with the "natural" delay of the calculation time.

Operation Zone1

The first stage of the distance protection can be disabled or can be directed forward or backward. The parameter value can be "Off, Forward, Backward", accordingly. The usual setting is forward, supposing that the fault current flows toward the protected line.

Zone1 Start Only

The trip command of the first zone of the distance protection can be inhibited using this parameter. If this Boolean parameter is set to "1" (logic TRUE) then the function is operable, but the trip command is blocked. Set 0 for „Zone1 Start Only“, to generate also a trip command.

PSD Block Z1

The distance protection function includes the embedded function for power swing detection. The role of this embedded function block is – among others – to block the trip command if the measured impedance is within the characteristic of the distance protection not because of fault but due to power swings. If this Boolean parameter is set to "1" (logic TRUE) then the detected power swing state blocks the trip command.

4.6.1.3.2. Setting the second impedance stage

The second impedance stage is usually delayed with a selective time step. This stage has certainly to operate in case of a fault at a small section on the far end of the line, which is not covered by the first stage. The operation has to be achieved even if the protection measures with a negative error:

$$Z^{II} \geq \frac{Z_V}{(1-\varepsilon)}$$

Where

Z^{II} is the setting of the second impedance stage.

If the outgoing lines from the far end busbar are protected with distance protection as well, then the second stage of our protection may not operate together or instead of the second stage of the protection on the shortest outgoing line. No overlapping of the characteristics is allowed, even if the far away protection operates with negative measuring error, and our protection has a positive measuring error:

$$Z^{II} \leq \frac{Z_V + (1-\varepsilon)Z_K^I}{(1+\varepsilon)} = \frac{Z_V + (1-\varepsilon)\frac{Z_K}{(1+\varepsilon)}}{(1+\varepsilon)}$$

Where

Z^{II} setting of the second stage,

Z_V positive sequence impedance of the line to be protected,
the security factor, usually 0.15

Z_K^I setting values of the far away line distance protection,

Z_K positive sequence impedance of the far away line.

If the far away line is too short, it is possible that the second stage of our protection overlaps the second stage of the following line distance protection. To avoid the non selective trip, the time setting has to be delayed with two selective time steps.

If the busbar at the far end of the line protected supplies a transformer, the second stage of our protection may not overreach the transformer, even if the measuring has a positive error:

$$Z^{II} \leq \frac{Z_V + Z_{TR}}{(1+\varepsilon)}$$

Z^{II} second stage impedance setting,

Z_{TR} impedance of the transformer,

Z_V positive sequence impedance of the line to be protected,

ε the security factor, usually 0.15.

The parameters to be set are as follows:

Operation Zone2
Zone2 Start Only
PSD Block Z2
Zone2 R
Zone2 X
Zone2 (Xo-X1)/3X1
Zone2 (Ro-R1)/3R1
Zone2 time delay

See the explanation for setting the first stage.

c

Note: In some applications the parameters “Zone2 (Xo-X1)/3X1” and “Zone2 (Ro-R1)/3R1” is considered to be equal to those of the Zone1. In this case, this parameter cannot be seen in the group of parameters for the second zone.

The time delay of the second stage is to be set in milliseconds, the value should be usually one selective time step. If however the far away line is too short, it is possible that the second stage of our protection intersects the second stage of the far away line distance protection characteristics. In this case, the time setting is delayed with two selective time steps.

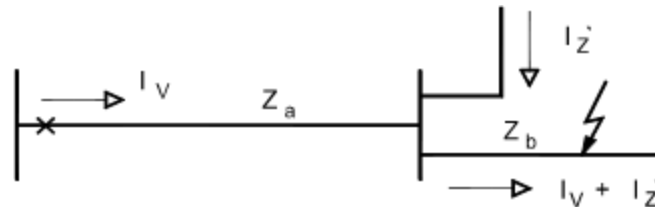

Figure 1-5 Distortion caused by power supply at the far line end

If a fault occurs on a next outgoing line (Figure 1-5), the protection measures a larger impedance than the impedance proportional with the distance, because of the distorting effect of the I_z' short-circuit current component delivered by a third line. The measured impedance will be greater than the real one, which means, that the border of the impedance stage is withdrawn. It is possible that the fault in the second zone and the protection trips only in the subsequent (third) stage, which means an additional time delay.

Setting the second stage as an overreaching stage

Application of overreaching stage with co-operation of an external automatic reclosing device can be effective to overcome the problems caused by the delayed fault clearing in case of faults near the far line end. Another application of overreaching is the “tele-protection” (see Chapter 7.4. in detail). In case of overreaching, the setting will cover completely the protected line, but the faults at the beginning of the outgoing line as well. The formula for setting is:

$$Z^{OVERREACH} \geq \frac{Z_v}{(1 - \epsilon)}$$

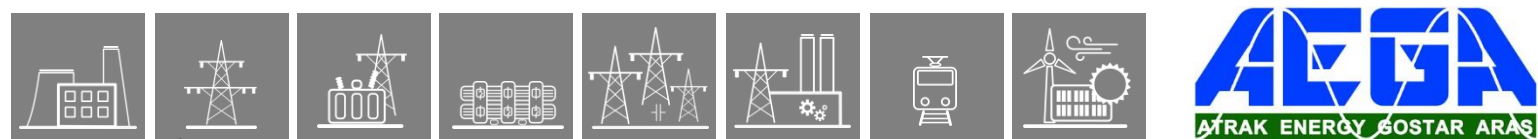

C

4.6.1.3.3. Setting the higher impedance stages

The role of these stages of the distance protection is to give back up protection to the following lines outgoing from the far busbar, or reverse backup protection, so it has not a main protection role. Due to the feeding distortion mentioned above (explained with Figure 1-5), this task cannot be fully achieved. Therefore, the most important setting aspect to be considered is to avoid faulty start on high power transmission on the line and on a power swing.

This stages can also serve special purposes (e.g. two second stages with two time delays and setting values in case of short outgoing line from the far away busbar, reverse zones, generation of inhibition signals for some “tele-protection” schemes to detect faults in reverse direction, etc.

Of course, this description cannot cover all network configurations, but the examples above show, that the setting of a protection must be co-ordinated with all other protections of the network. When determining the setting values, a great care must be taken. A too high setting value for the third stage is not advised. The same statement is valid for all higher stages as well.

The time delay of these stages has an additional selective time step.

The parameters for the stages 3, 4, 5 are as follows:

Operation Zone3, 4, 5
Zone3,4,5 Start Only
PSD Block Z3,4,5
Zone3,4,5 R
Zone3,4,5 X
Zone3,4,5 (Xo-X1)/3X1
Zone3,4,5 (Ro-R1)/3R1
Zone3,4,5 time delay

See the explanation for the first stage setting.

The time delay of these stages is given in milliseconds, the value is usually the delay time of the second stage plus at least one selective time step. The value can be determined only knowing the total protection system.

The backward stages can form a natural bus-bar protection for the substation. If the time delay is shorter than that of the distance protection second stage at the far away line end, then the nearest circuit breakers will be disconnected on busbar fault. Since this stage must detect close-in faults as the busbar fault, the impedance setting must be appropriately small. In this role, the impedance setting of the reverse stage can be safely smaller, than the setting of the protection for the shortest line.

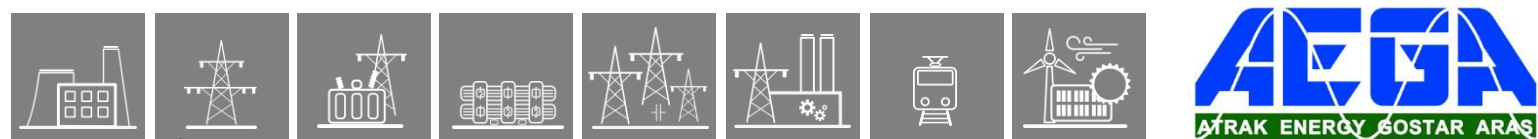

C

4.6.2. Binary signals influencing of the distance protection function

4.6.2.1. Binary inputs of the distance function block

The **binary inputs** of the distance protection function block are signals influencing the operation. These signals are the results of the logic schema, graphically edited by the user.

Binary input signals	Signal title	Explanation
DIS21_VTS_GrO_	Block from VTS	Blocking signal due to error in the voltage measurement
DIS21_Z1Blk_GrO_	Block Z1	Blocking of Zone 1
DIS21_Z2Blk_GrO_	Block Z2	Blocking of Zone 2
DIS21_Z3Blk_GrO_	Block Z3	Blocking of Zone 3
DIS21_Z4Blk_GrO_	Block Z4	Blocking of Zone 4
DIS21_Z5Blk_GrO_	Block Z5	Blocking of Zone 5
DIS21_PSDBlk_GrO_	Block PSD	Blocking signal for power swing detection
DIS21_SOTFCond_GrO_	SOTF COND.	Status signal indicating switching-onto-fault condition

Table 1-6 Binary input signals influencing the operation of the distance protection function block

Block from VTS

If there is no voltage for impedance calculation then the distance protection function must be blocked. The blocking signal can be generated from

- the auxiliary contact of the miniature circuit breaker in the voltage transformer secondary circuit, or
- the voltage transformer supervision (VTS) function block.

The application of the auxiliary contact of the miniature circuit breaker in the voltage transformer secondary circuit is shown for common contact in Figure 1-6, for individual auxiliary contacts in Figure 1-7. This mode of application generates a logic TRUE signal, if the contacts are closed. This signal is connected to a binary input of the device.

Another possibility for supervision is the application of the voltage transformer supervision (VTS) function block. See the details in the manual “**Voltage transformer supervision and dead line detection function block description**”. Depending on the setting, this function block generates a signal, if the detected asymmetry of the three-phase currents differs from the type of asymmetry measured in the three-phase voltages.

These signals are connected in the graphic logic editor to the VTS input of the distance protection function block (DIS 21). See Figure 1-8.

C

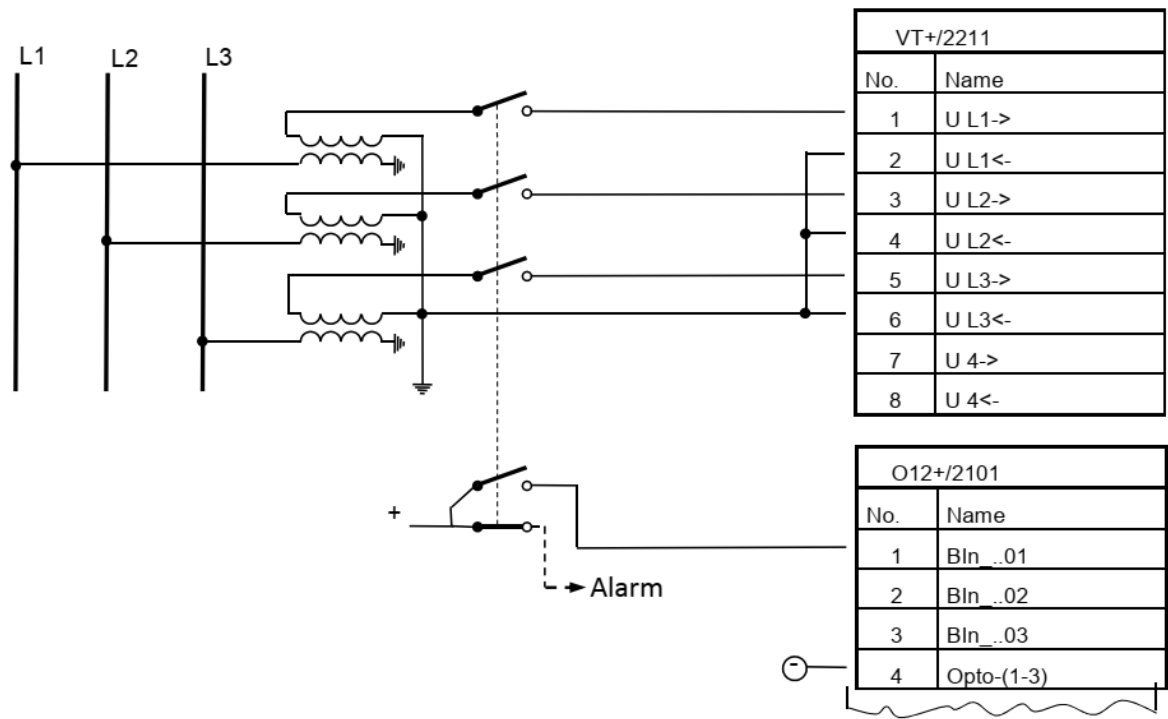

Figure 1-6 Common auxiliary contact for the VT miniature circuit breakers

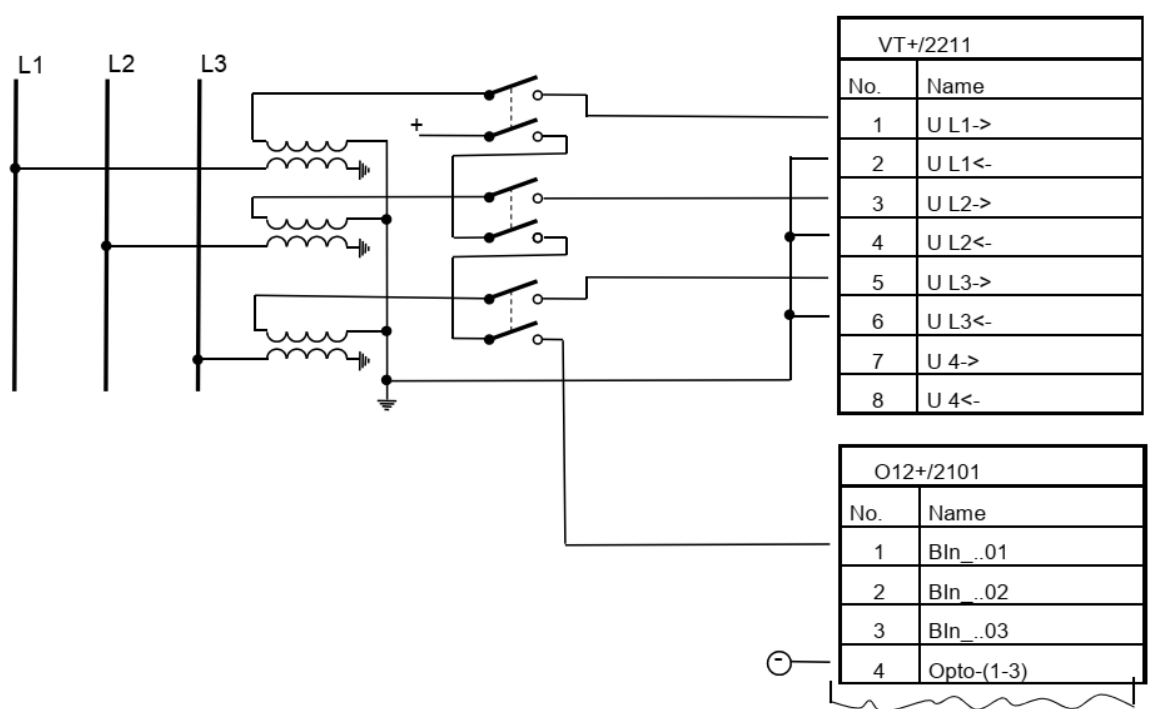

Figure 1-7 Individual auxiliary contacts for the VT miniature circuit breakers

C

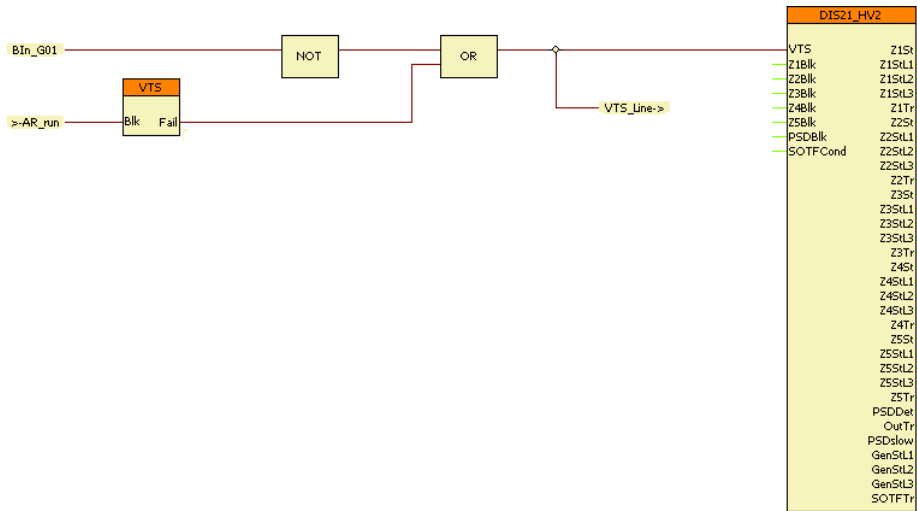

Figure 1-8 Example: Blocking of the distance protection function due to voltage measurement error (Detail)

Block Z1-5

If needed, the individual zones of the distance protection function can be blocked by user-defined signals. These signals are connected in the graphic logic editor to the “Z_Blk” inputs of the distance protection function blocks. The individual signals can be edited by the user, according to special requirements.

Block PSD

The distance protection function includes the embedded function for power swing detection. The role of this embedded function block is – among others – to block the trip command if the measured impedance is within the characteristic of the distance protection not because of fault but due to power swings.

The operation of this embedded function can be blocked with this input signal. The conditions for blocking can be edited by the user using the graphic logic editor of the EuroCap configuration software.

SOTF COND

The distance protection function needs to decide the direction of the fault. This decision is based on the angle between the voltage and the current. In case of close-up faults, however, the voltage of the faulty loop is near zero: it is not sufficient for a directional decision. If there are no healthy phases, then the voltage samples stored in the memory are applied to decide if the fault is forward or reverse.

If the protected object is energized, the close command for the circuit breaker is received in “dead” condition. This means that the voltage samples stored in the memory have zero values. In this case, the decision on the trip command is based on the programming of the protection function for the “switch-onto-fault” condition.

This “switch-onto-fault” detection function prepares the conditions for the subsequent decision. See the details in the manual “**Switch-onto-fault preparation function block description**”.

The manual close command is an input binary signal. The drop-off of the output signal ManSOTF is delayed by a timer with timing set by the user.

C

The application of this input is shown in Figure 1-9.

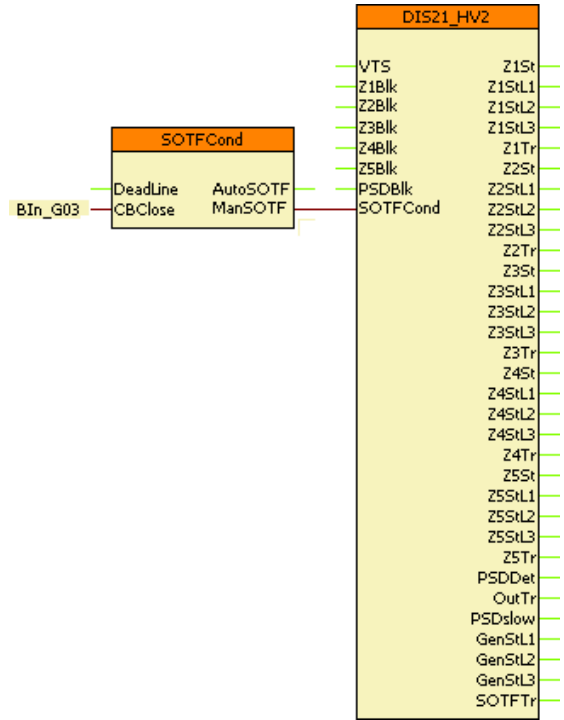

Figure 1-9 Example: Application of the SOTFCond function block (Detail)

4.6.3. The current conditions of the distance protection function

The distance protection function can operate only if the current is sufficient for impedance calculation. Additionally, a phase-to-ground fault is detected only if there is sufficient zero sequence current. The setting values in this chapter support these preliminary decisions.

4.6.3.1. The parameters of the current condition

Integer parameters

Parameter name	Title	Unit	Min	Max	Step	Default
Definition of minimal current enabling impedance calculation:						
DIS21_Imin_IPar_	IPh Base Sens	%	10	30	1	20
Definition of zero sequence current characteristic enabling impedance calculation in phase-to-earth loops:						
DIS21_IoBase_IPar_	IRes Base Sens	%	10	50	1	10
DIS21_IoBias_IPar_	IRes Bias	%	5	30	1	10

Table 1-7 Integer parameters for the current conditions module

The current is considered to be sufficient for impedance calculation if it is above the level set by parameter “IPh Base Sens”.

To decide the presence or absence of the zero sequence current, biased characteristics are applied (see Figure 1-10). The minimal setting residual current (IRes Base Sens.) and a percentage biasing IRes Bias must be set. The biasing is applied for the detection of residual current in the case of increased phase currents.

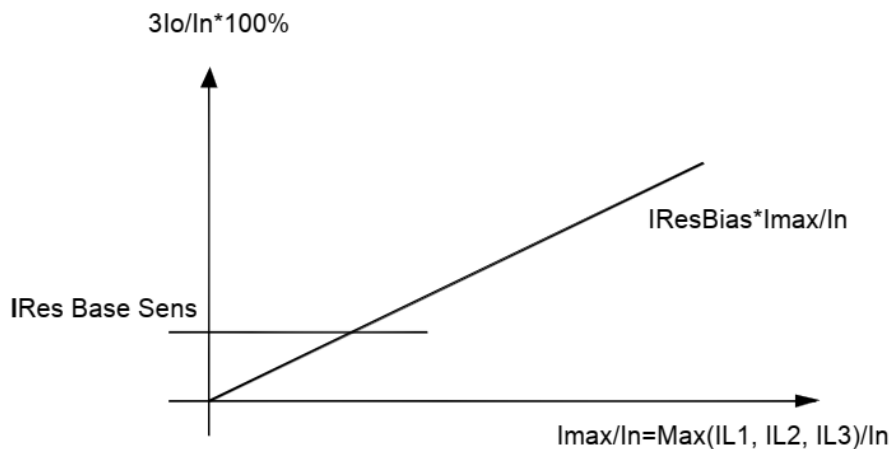

Figure 1-10 Percentage characteristic for earth-fault detection

4.6.3.2. Setting the zero sequence current detection

The zero sequence current detection is needed to separate earth faults and faults without earth contact. This separation prevents for example that in case of close-in A-N phase-to-earth fault the measured impedance in the phase-to-phase loops CA or AB could disturb correct decision. If considerable zero sequence current is detected, then the results calculated for phase-to-phase loops are not taken into consideration. Another example can be a fault between phases B and C, when small impedance is detected in phase-to-earth loops B-N and C-N as well, but in case of BC fault, there is no zero sequence current, so the measured values for phase-to-earth loops can be excluded from the decision.

To decide the presence or absence of the zero sequence current, biased characteristics are applied which avoid starting on phase-to-phase faults with high current. The minimal setting current (IRes Base Sens) and a percentage biasing (IResBias) is to be set (See Figure 1-11).

C

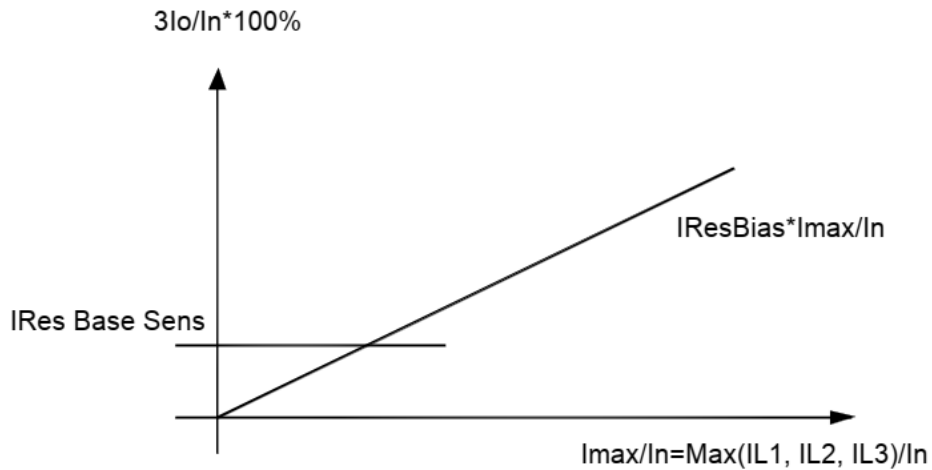

Figure 1-11 Zero sequence current detection with biased characteristics

IRes Base Sens

The correct setting needs the following considerations:

The zero sequence current detection setting should be sensitive enough to detect the smallest possible zero sequence current in case of a phase-to-earth fault or a double phase-to-earth fault. The selectivity is needed mainly in case of faults in the base zone, which is the first stage and the second stage of the distance protection, i.e. the line to be protected. So the smallest zero sequence current must be determined with a series of short-circuit calculations. It is necessary to calculate faults in the reverse zone as well.

The setting value is limited by the zero sequence currents, which can be detected in case of faults without earth. Principally there are no zero sequence currents in these kinds of faults; even so, zero sequence current can be detected. They are caused for example by the current and phase errors of the current transformers, by the saturation differences between the phase CT-s, and by the zero sequence error currents due to the asymmetrical arrangement of network elements as well.

Usually, the two considerations above do not cause any difficulties in setting. The setting range is 10-50 % of the current transformer rated value.

IRes Bias

The biasing is needed, because the errors of the current transformers increases with increasing phase currents on fault. The setting range is 5-30 % of the current transformer rated value.

4.6.3.3. Setting the starting current to limit line impedance calculation

The impedance cannot be calculated with the required accuracy if the current value is too low. To avoid errors, limit current is to be set as follows:

IPhBase Sens

Based on experiences the factory setting of this parameter usually assures correct operation of the function.

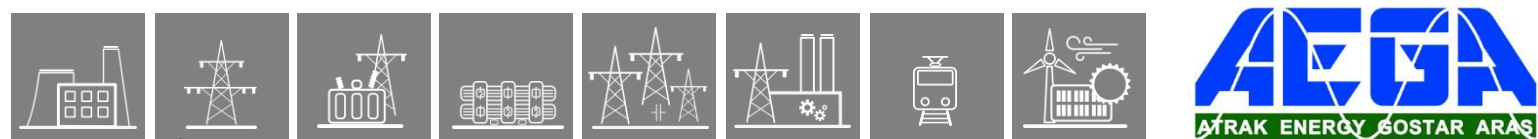

C

compared to the voltage at the other end, then this function generates a status signal. This signal can be enabled (On) or disabled (Off), using this parameter.

PSD Block Z1

If this Boolean parameter is set to logic TRUE (1) then the detected power swing blocks the trip command of Zone1.

PSD Block Z2

PSD Block Z3

PSD Block Z4

PSD Block Z5

These parameters have the same effect to higher zones as the parameter “PSD block Z1” to Zone 1.

Note: Consider that higher zones have usually high time delay setting (500 ... 2500 ms). The slowest power swing in a stable network is not lower than 2 Hz. It means that the impedance within 500 ms performs a whole period of the swing, consequently the trajectory of the impedance leaves the impedance zone again; the timer of the impedance zone cannot reach the tripping state. Consequently, these zones need not be involved in power swing blocking.

PSD Xinner

PSD Rinner

These parameters define characteristic of power swing detection. See Figure 1-12.

The required setting of these parameters is in close relationship with the selection “PDS Block_x”. These values should be set higher than the setting of the selected impedance zones. Example: if the Zone 3 has the highest impedance setting among the zones to be blocked by the power swing, then the recommended setting is:

$$\begin{aligned} \text{PSD Xinner} &> k_x * \text{Zone3 X} \\ \text{PSD Rinner} &> k_r * \text{Zone3 R} \end{aligned}$$

Where Zone3 X is the X setting for Zone3

Zone3 R is the R setting for Zone3

k_x is a security factor in X direction, at least 1.2

k_r is a security factor in R direction. This factor should be selected high enough to exclude the upper right corner (in this example) of the Zone 3 distance characteristic.

Example:

Zone3 R = 15 Ohm

Zone3 X = 10 Ohm

Line Angle = 73°

$$\text{PSD Rinner} = 1.2 * (\text{Zone3 R} + \text{Zone3 X} * \text{ctg}(\text{Line Angle}))$$

$$= 1.2 * (15 \text{ Ohm} + 10 \text{ Ohm} * \text{ctg}(73^\circ)) = 21.67 \text{ Ohm} \cong 22 \text{ Ohm}$$

$$\text{PSD Xinner} = 1.2 * 10 \text{ Ohm} = 12 \text{ Ohm}$$

PSD R_out/R_in

PSD X_out/X_in

These two parameters, with the parameters “PS Rinner” and “PSD Xinner” define an impedance band. The time, needed for the measured impedance to pass this band is decisive for the power swing detection. If this time is short then a fault is detected; the trip command may not be blocked. If however, the time is above the “PSD Time Delay” setting, then power swing is detected, the trip command is blocked.

Consequently, these parameters have to be considered together with the parameter “PSD Time Delay”.

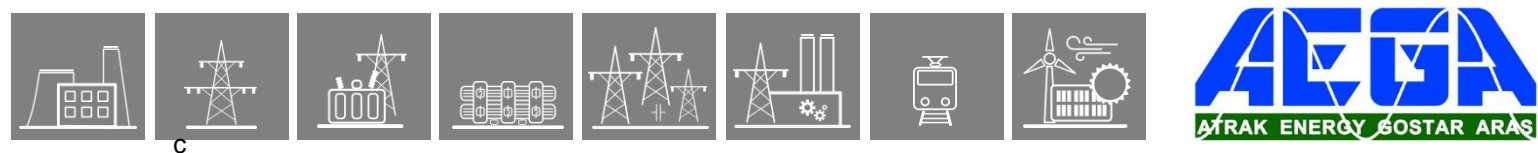

C

4.6.5. The distance-to-fault calculation (FAULT LOCATOR)

The distance protection function selects the faulty loop impedance (its positive sequence component) and calculates the distance to fault based on the measured positive sequence reactance and the total reactance of the line. This reference value is given as a parameter setting "Line Reactance". The calculated percentage value facilitates displaying the distance in kilometers if the total length of the line is correctly set by the parameter "Line Length".

4.6.5.1. The parameters for distance-to-fault calculation

Floating point parameters

Parameter name	Title	Dim.	Min	Max	Default
DIS21_Lgth_FPar_	Line Length	km	0.1	1000	100
DIS21_LReact_FPar_	Line Reactance	ohm	0.1	200	10

Table 1-13 The floating point parameters

4.6.5.2. Setting

Example for setting the line data

For the setting procedure, the following data are necessary:

Data:

120 kV overhead line,

length: length = 40 km

per unit positive sequence reactance: $x1 = 0.41 \Omega/\text{km}$

voltage transformer turns ratio: $au = 120 \text{ kV}/0.1 \text{ kV}$

current transformer turns ratio: $ai = 600 \text{ A} / 5 \text{ A}$

Calculation:

Line Length

Set Line Length = 40 km.

Line Reactance

The primary reactance to be set:

$$X_{\text{prim.}} = \text{length} * x1 = 40\text{km} * 0.41 \Omega/\text{km} = 16.4 \Omega$$

Transformed to secondary value:

$$X_{\text{second.}} = ai/au * X_{\text{prim.}} = (600/5) / (120/0.1) * 16.4 \Omega = 1.64 \Omega$$

The value to be set:

$$\text{Line Reactance} = X_{\text{second.}} = \underline{1.64 \Omega}$$

C

4.6.6. The high-speed overcurrent protection function with switch-onto-fault logic (HSOC SOTF)

The switch-onto-fault protection function can generate an immediate trip command if the function is enabled and switch-onto-fault condition is detected. The condition of the operation can be the starting signal of any distance protection zone as it is selected by a dedicated parameter, or it can be the operation of the high-speed overcurrent protection function.

The high-speed overcurrent protection function operates if a sampled value of the phase current is above the setting value.

4.6.6.1. The parameters for the switch-onto-fault logic

The parameters of the SOTF function are explained in the following tables.

Enumerated parameters

Parameter name	Title	Selection range	Default
Parameter for selecting one of the zones or “high speed overcurrent protection” for the “switch-onto-fault” function:			
DIS21_SOTFMd_EPar _	SOTF Zone	Off,Zone1,Zone2,Zone3,Zone4,Zone5 ,HSOC	Zone1

Table 1-14 The enumerated parameters of the SOTF function

Integer parameters

Parameter name	Title	Unit	Min	Max	Step	Default
Definition of the overcurrent setting for the switch-onto-fault function, for the case where the DIS21_SOTFMd_EPar_ (SOTF Zone) parameter is set to “HSOC”:						
DIS21_SOTFOC_IPar_	SOTF Current	%	10	1000	1	200

Table 1-15 The integer parameters of the SOTF logic

4.6.6.2. Setting

The general condition to generate a trip command in case of switch onto fault is that the dedicated input “SOTF COND” of the distance protection function block should be active. This signal indicates that in dead state a close command is performed. See Chapter 1.2, and an example in Figure 1-9. The second condition is that additionally a fault is detected. The fault can be detected by any of the distance protection zones or by the high-speed overcurrent (HSOC) function. The selection is the user’s choice with setting the “SOTF Zone” parameter.

SOTF Zone

This parameter selects either one of the distance protection zones or the high-speed overcurrent protection function.

When selecting a distance zone (e.g. “Zone3”, see Table 1-14) then the additional condition for the trip command is the start signal of this zone. For the decision, the directional parameter of this zone is considered “NonDirectional” independently on the setting (See Table 1-1).

When selecting “HSOC” then the additional condition for the trip command is the operation of the embedded function “HSOC”. This high-speed overcurrent protection function operates within one network period, if the measured current is above the setting value “SOTF Current”.

SOTF Current

Set this current safely above the highest load current, considering the possible inrush currents in healthy operation, but possibly below the lowest short-circuit current, which can be expected after a close command. No time delay setting is applied.

4.6.7. Setting in some special applications

4.6.7.1. Setting for a transmission line with more than two terminals

If the line connects more than two substations, then the setting of the first stage of the protection at busbar “A” in Figure 1-13 should be based on the shortest distance of AC or AB. If the shortest distance is AB then the setting is:

$$Z_A^I = \frac{Z_{AB}}{1 + \epsilon}$$

As the protection cannot measure the exact distance between “A” and the fault in case of fault between T and C, due to the problem caused by the feeding distortion of the intermediate third supply, the setting of the second stage must be accordingly longer.

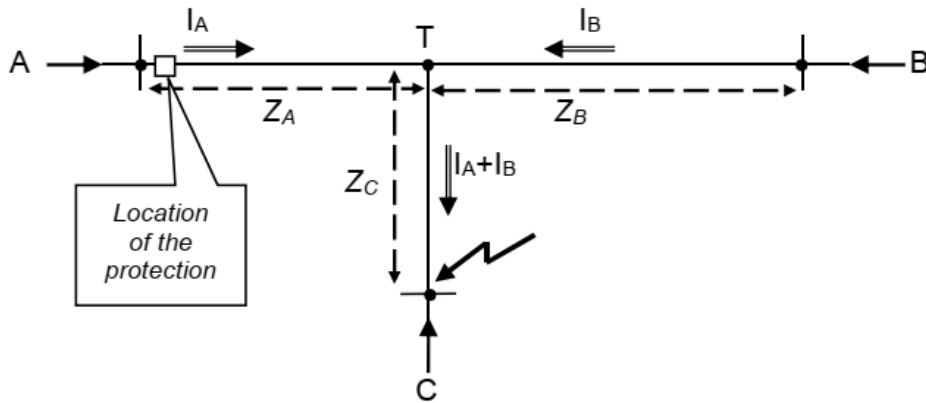

Figure 1-13 Distance measurement on lines with three terminals

According to Figure 1-13 the measured impedance is:

$$Z_{measured} = Z_A + \frac{I_A + I_B}{I_A} Z_C$$

This value is higher than the impedance $Z_A + Z_C$ proportional with the distance. The correct impedance setting for the second zone is:

$$Z_A^{II} \geq \frac{Z_{measured}}{1 - \epsilon} = \frac{1}{1 - \epsilon} \left(Z_A + \frac{I_A + I_B}{I_A} Z_C \right)$$

Here the highest possible feeding distortion factor $\frac{I_A + I_B}{I_A}$ on different network conditions must be considered.

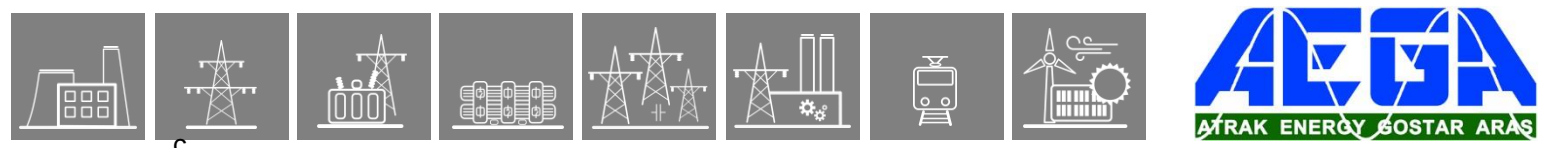

C

4.6.7.2. Distortion caused by parallel lines

If two line systems are mounted on the same tower, then the zero sequence current flowing in the parallel line, through the zero sequence inductive coupling will result zero sequence induced voltage in the line to be protected. This induced voltage will distort the measured impedance in case of earth faults. The direction of the induced voltage in the protected line depends on the zero sequence current direction on the parallel line.

The smallest possible impedance measured in case of fault at the end of the line must be determined, and the first stage of the differential protection must be set accordingly:

$$Z^I \leq \frac{Z_{meas._min}}{(1 + \epsilon)}$$

It is a smaller value than the needed setting without parallel effect.

The highest impedance must be similarly determined, and the setting of the second stage of the differential protection is to be set as follows:

$$Z^{II} \geq \frac{Z_{meas._max}}{(1 - \epsilon)}$$

It is a higher value than the needed setting without parallel effect.

As the second stage in case of measured $Z_{meas._min}$ may reach far into the next line, the time delay must be increased if necessary by two selective time steps. The disadvantage of the additional time delay can be avoided using a “teleprotection” scheme, whose result is quick fault clearing along the protected line.

As an option, the zero sequence current compensation for parallel lines can be considered. If so the current flowing in the parallel line must be connected to the dedicated input of the device, and the parameters β_R and β_L must be set accordingly (See section 1.1.1.1).

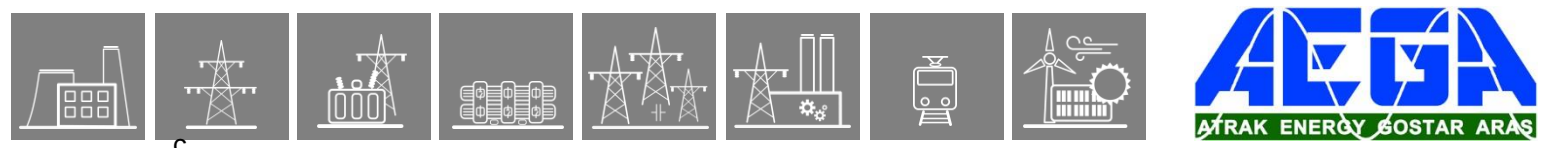

C

4.6.8. Appendix: Compensation of the distance distortion due to the power transfer and the fault resistance

The algorithm of the distance protection calculates the fault distance based on the measured reactance value.

If the fault resistance at the fault location cannot be neglected and before fault inception there is considerable power transfer on the protected line then the calculated reactance value – consequently the calculated distance to fault - is distorted. This distortion means overreaching (or underreaching) of the distance protection. Overreaching can result operation also in case of fault outside the protected zone, resulting unselective tripping.

To compensate this distortion of the measured distance the X border line of the polygon-shaped characteristic can be tilted downwards or upwards, depending on the amount and direction of the pre-fault power transfer on the protected line. The angle value of tilting needs technical consideration. This method of calculation is explained below.

4.6.8.1. Calculation for three-phase fault

For the calculation the power system is reduced to two points; the protected line is located between these points, fed by two equivalent generators. The calculation is performed with the application of the superposition. The following two components are superposed:

- The first component is the pre-fault steady state, where the pre-fault voltage at the fault location is calculated.
- The fault is added by connection the pre-fault voltage multiplied by (-1) at the fault location of the deactivated network.

The sum of the two components results the faulty state during power transfer on the line.

The superposed results of the calculation result the voltages and currents at the location of the protection. These values are substituted in the measuring equations of the distance protection algorithm.

When comparing the “measured” impedance with the impedance of the protected line, the distortion can be evaluated. This distortion is to be compensated by “tilting” the reactance line of the distance protection.

When explaining the method of calculation below the several influencing factors can also be evaluated.

To derive the information for practical purposes a software is prepared for fault simulation. The diagrams published in this description are the results calculated by this simulation software.

4.6.8.1.1. Model of the pre-fault power transfer

The model with the parameters is shown in Figure 2-1.

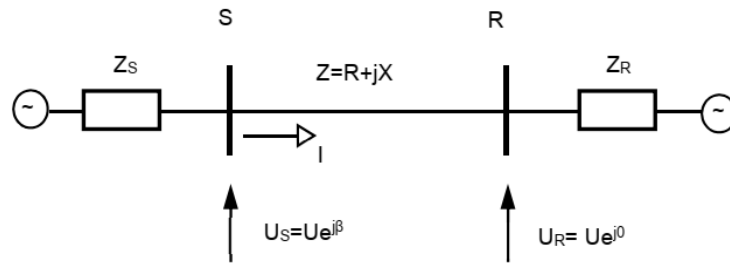

Figure 2-1 Model of the pre-fault power transfer

In this model, the reference voltage is the voltage of the R (receiving) end of the protected line. Here:

$$U_R = \frac{U_N}{\sqrt{3}}$$

This R point will be the fault location. The protection is located at the S (sending) line end.

In the pre-fault steady state, the power transfer can be calculated using the following simplified formula:

$$P = \frac{U^2}{X} \sin(\beta)$$

(Note: When calculating with line-to-line voltages, the power is the three-phase power; substituting phase-to-ground voltages, the single-phase power is calculated.)

The approximation of this formula is neglecting the power loss of the line, but this approximation is acceptable.

The "X" reactance is measured between two points, where the voltage angle difference between them is " β ". In some calculation, these two points are the internal points of the equivalent Thevenin generators. In this application however, these points are the R and S ends of the line, the "X" reactance is consequently the reactance of the line.

Another approximation can be to consider the magnitude of the voltages at both line ends to be the same. Consequently, the power transfer is determined by the β angle only.

When substituting a given power the required β angle is:

$$\beta = \frac{\arcsin PX}{U^2}$$

If the reference voltage is the R side voltage then the voltage at the S line end (this is the pre-fault voltage at the relay location) is:

$$U_S = Ue^{j\beta}$$

At this location the pre-fault current is:

$$I_S = \frac{U[(e^{j\beta}) - 1]}{Z}$$

4.6.8.1.2. Modeling a three-phase fault component

For the simple explanation, let us start with a three-phase fault. The second component of the superposition is calculated using the schema of Figure 2-2.

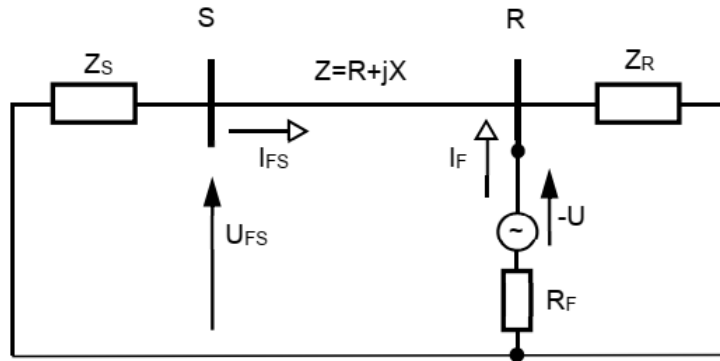

Figure 2-2 Model for three-phase fault component calculation

Seen from the fault location the resulting impedance of the network is:

$$Z_e = \frac{(Z_s + Z) * Z_R}{Z_s + Z + Z_R} + R_F$$

The current at the fault location is:

$$I_F = \frac{-U}{Z_e}$$

The fault current component at the relay is calculated by current division:

$$I_{FS} = I_F \frac{Z_R}{Z_s + Z + Z_R}$$

The fault voltage component at the relay location is:

$$U_{FS} = 0 - Z_s * I_{FS}$$

4.6.8.1.3. The superposition for three-phase fault

With summation of the two components calculated above, the voltage and the current measured by the relay are:

$$U_{FProt} = U_s + U_{FS}$$

$$I_{FProt} = I_s + I_{FS}$$

4.6.8.1.4. Impedance calculation

It is well known that in case of a three-phase fault, in all six measuring loop the result of the calculation is the positive sequence impedance of the line between the relay and the fault location. Let us select the L1-N loop. Here:

$$Z_{Prot} = \frac{U_{FProt}}{I_{FProt} + komp * 3I_0} = R_{Prot} + jX_{Prot}$$

The zero sequence current compensation factor would be:

$$komp = \frac{Z_0 - Z_1}{3 * Z_1}$$

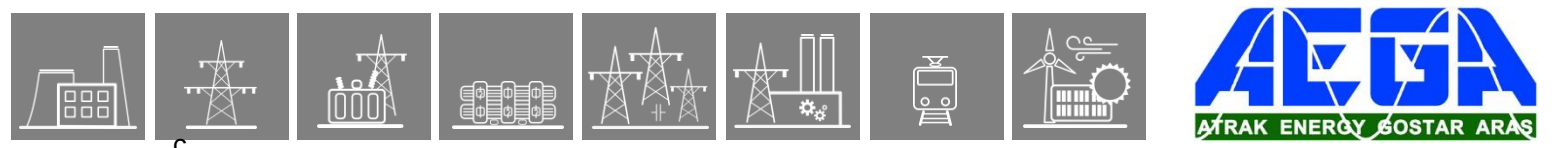

C

In case of a three-phase fault however the zero sequence current component is $I_0 = 0$.

When drawing the impedance of the line and the calculated impedance in the same coordinate system, the distortion of the impedance can be evaluated and the required tilting of the characteristic with a Θ angle to compensate the distortion can be seen. See Figure 2-3.

$$\theta = \arctg \frac{X - X_{Prot}}{R_{Prot} - R}$$

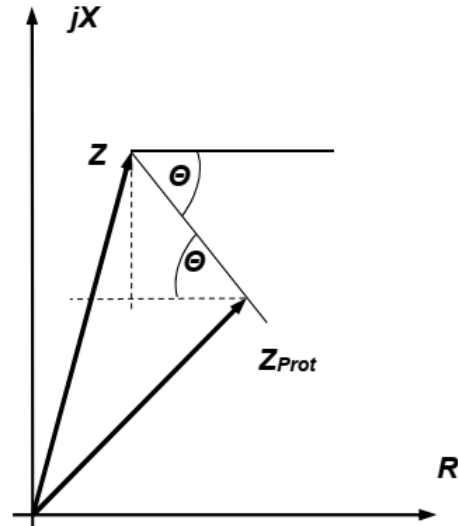

Figure 2-3 Distortion of the measured impedance

4.6.8.2. Calculation example

The example below shows the method of calculation for a three-phase fault.

The data of the network correspond to a 400 kV transmission line. These can be identified on the screenshot of the simulation software in Figure 2-4.

The screenshot shows that the angle between the voltages at the line ends is 25° (Beta) which results 995 MW pre-fault power transmission. If in this state the fault resistance is 10 ohm then the required tilting of the X characteristic line is -27.64° (Theta).

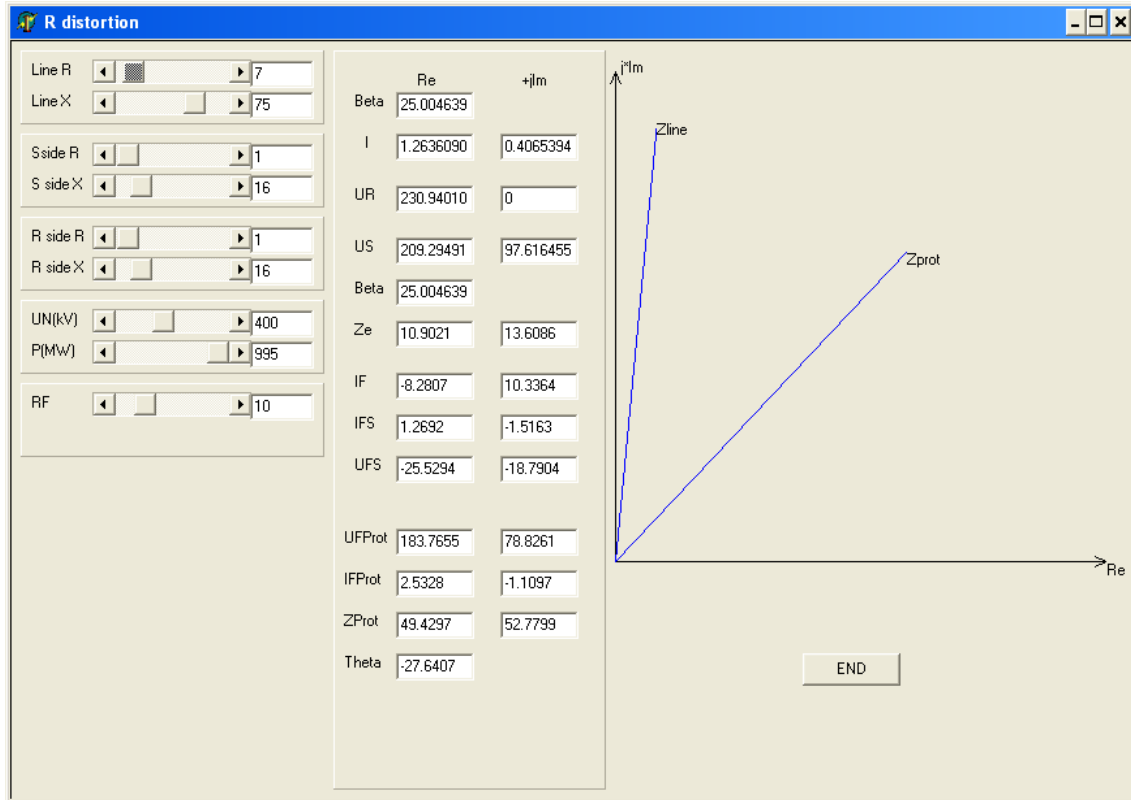

Figure 2-4 Screenshot of the simulation software for three-phase fault

When operating the sliders in the simulation software, the influence of different factors can be studied, and as a result, diagrams can be drawn. The Table and the diagrams below show examples.

							P(MW)	Average
RF(Ohm)	0	10	20	30	40	50		
Beta(°)	(°)	(°)	(°)	(°)	(°)	(°)		(°)
0	1.23	1.23	1.23	1.23	1.23	1.23	0	1.23
5	7.31	7.34	7.38	7.41	7.43	7.45	187	7.386667
10	13.32	12.97	12.66	12.44	12.21	12.05	377	12.60833
15	19.24	18.16	17.32	16.71	16.24	15.58	572	17.20833
20	25.09	23.04	21.57	20.59	19.86	19.32	777	21.57833
25	30.84	27.64	25.53	24.14	23.21	22.5	995	25.64333

Figure 2-5 Calculated results for three-phase fault

Based on the calculated results the following diagram can be drawn. See Figure 2-6.

C

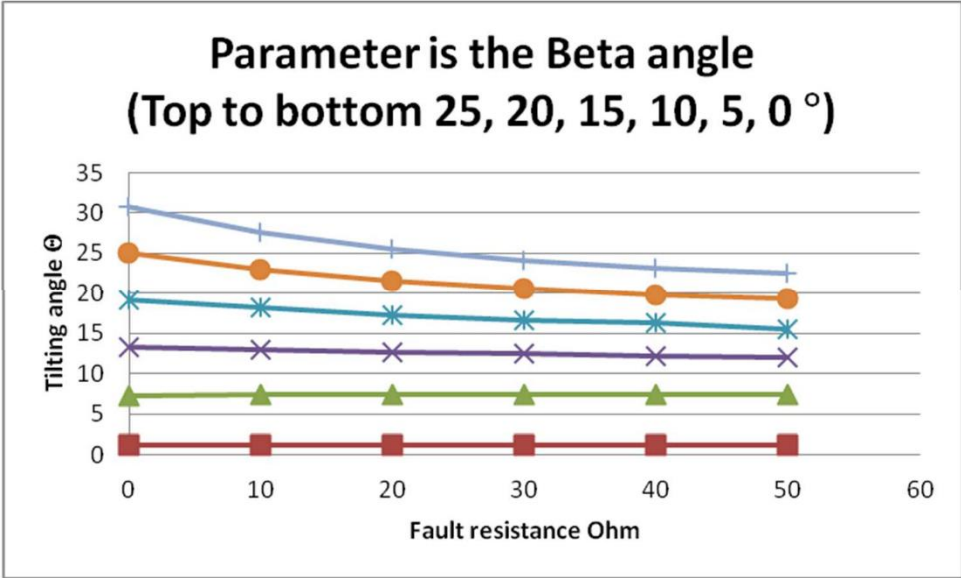

Figure 2-6 Diagram for three-phase fault

Figure 2-6 shows that the required tilting angle changes relatively small in the function of the fault resistance. Consequently, it is justified to calculate the average value for each Beta angle, and to draw a diagram, which shows this average value as the function of the Beta angle. This diagram is shown in Figure 2-7.

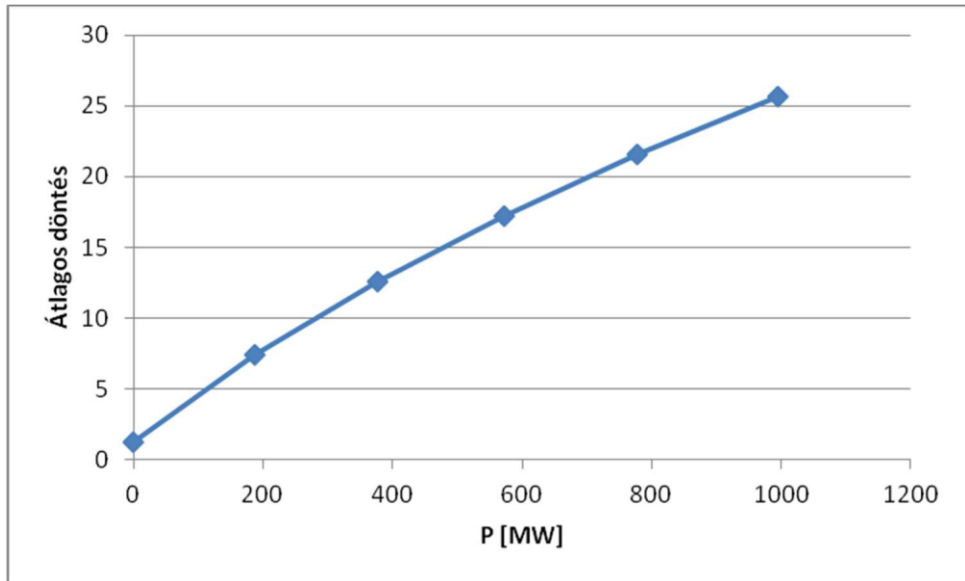

Figure 2-7 Average tilting angle for three-phase fault

When setting the required tilting angle in the parameter set of the protection, the maximum angle calculated for the “rated” power can be selected. In case of moderate power transfer, the algorithm proportionally decreases (in 3 steps) the actual tilting angle. For reverse power direction, however the slope of the X characteristic line is positive, increasing the operating area of the impedance plane.

4.6.8.3. Influence of asymmetrical faults

This chapter discusses a single phase to ground fault to find general conclusions.

4.6.8.3.1. Modeling a the pre-fault component

The pre-fault power transfer does not depend on the type of fault. Consequently, the first component of the superposition is the same as described in Chapter 2.1.1.

4.6.8.3.2. Modeling a single-phase-to-ground fault component

The schema for calculation of the second component of the superposition is shown in Figure 2-8.

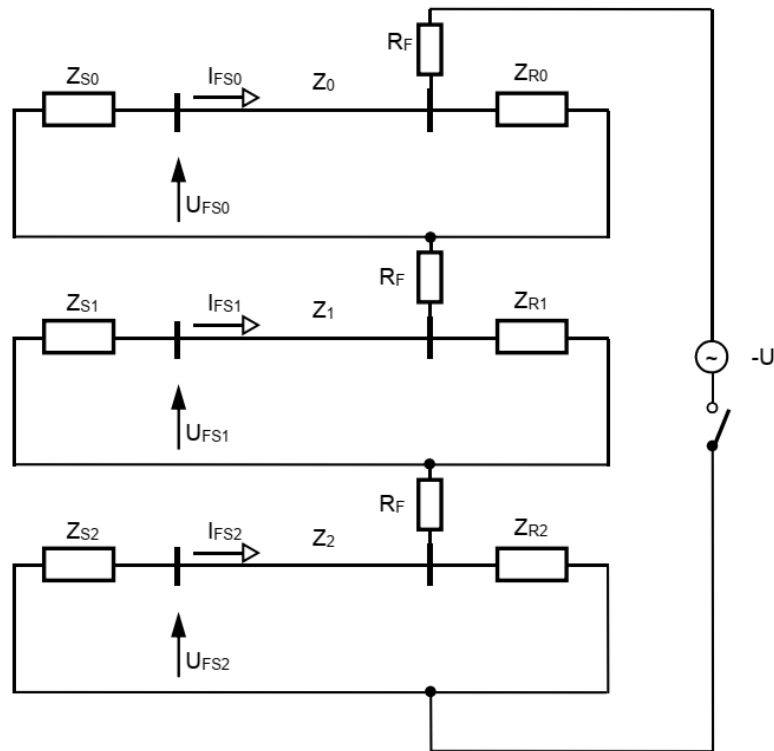

Figure 2-8 Model for single-phase fault component calculation

This model includes the inactivated positive, negative and zero sequence network equivalents in serial connection via R_F fault resistance. Based on this schema the procedure of the calculation is as follows:

- Calculate the resulting impedances of the symmetrical component networks;
- Calculate the positive, negative and zero sequence current component on the fault location;
- Calculate the component currents at the relay location;
- Calculate the component voltages at the relay location;
- Calculate the phase currents at the relay location;
- Calculate the phase voltages at the relay location.

4.6.8.3.3. The superposition

The superposition means in this case adding the pre-fault voltages and currents and the single-phase-to-ground fault voltages and currents at the relay location.

4.6.8.3.4. Impedance calculation

In the formula for impedance calculation, in the phase-to-ground fault loop the superposed voltage and current is substituted (including the zero sequence current compensation) to calculate the fault impedance.

4.6.8.4. Calculation example

The example below shows the method of calculation for a phase-to-ground fault.

The data of the network correspond to a 400 kV transmission line with the modification that the zero sequence impedances are supposed to be identical with the positive sequence impedances. These can be identified on the screenshot of the simulation software in Figure 2-9.

The screenshot shows that the angle between the voltages at the line ends is 25° (Beta) which results 995 MW pre-fault power transmission. If in this state the fault resistance is 10 ohm then the required tilting of the X characteristic line is -27.64° (Theta). This is the same as the result for three-phase fault.

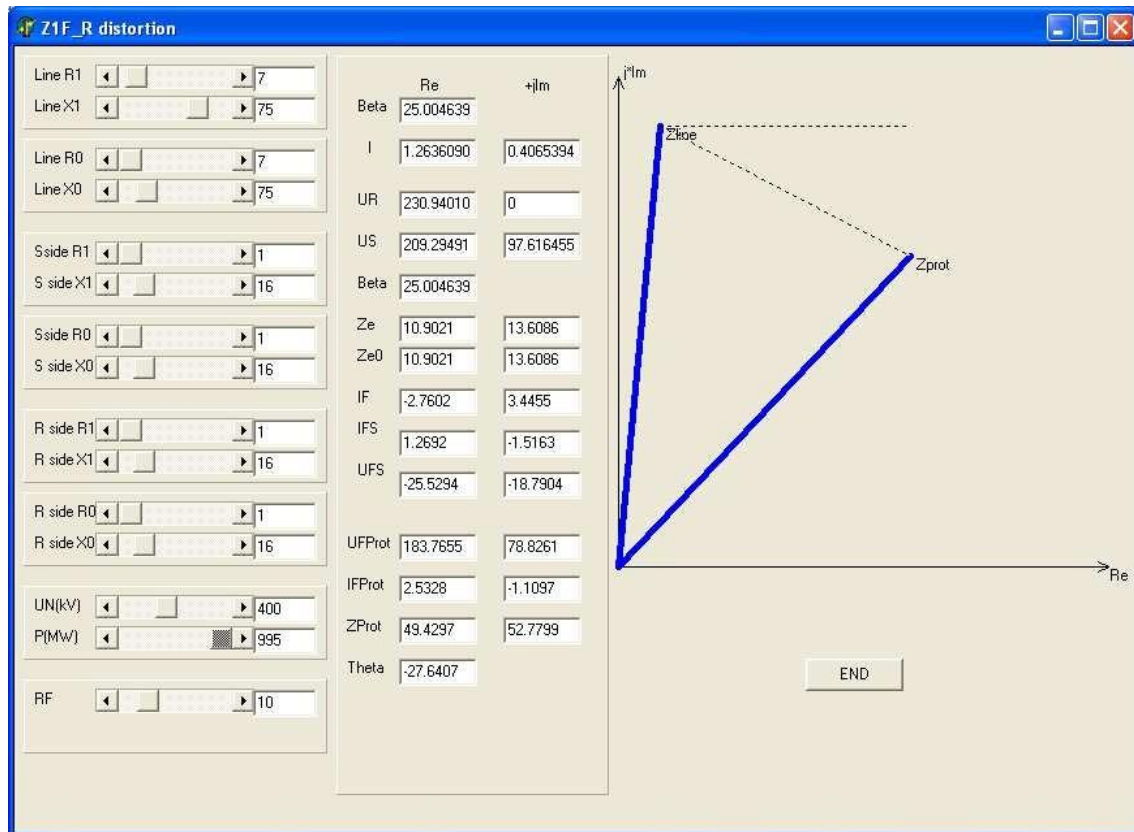

Figure 2-9 Screenshot of the simulation software for phase-to-ground fault

C

If data that are more realistic are set, (the zero sequence impedance is four times positive sequence impedance) then the results slightly deviate.

In the example below with 25° voltage angle (Beta) the power transfer is 995 MW. A 10 ohm fault resistance results the need of -26.79° (Theta) tilting of the X characteristic line. See Figure 2-10.

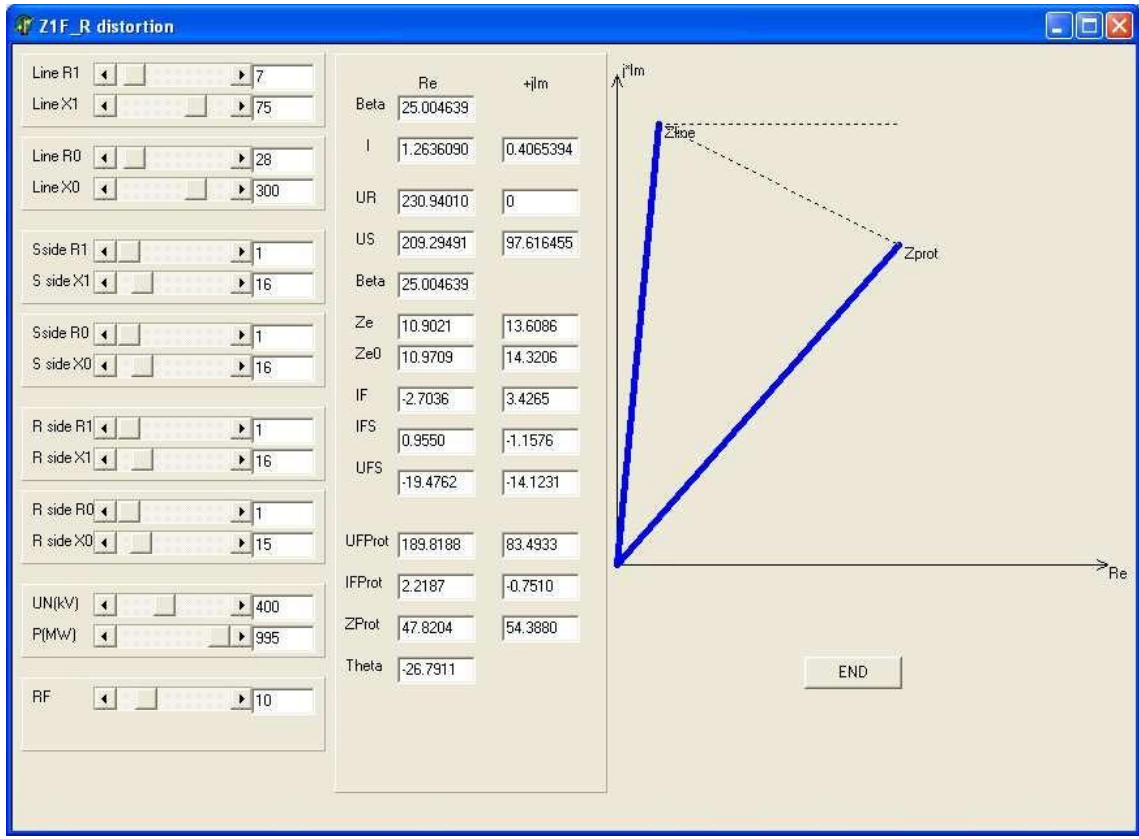

Figure 2-10 Screenshot of the simulation software for phase-to-ground fault

When changing other parameters in the simulation, the calculation seems to be more sensitive. As an example the short-circuit power at the far line end (R side) has considerable influence on the results. See Figure 2-11. These parameters are results of a network reduction; they include the effect of large number of network components and the network configuration.

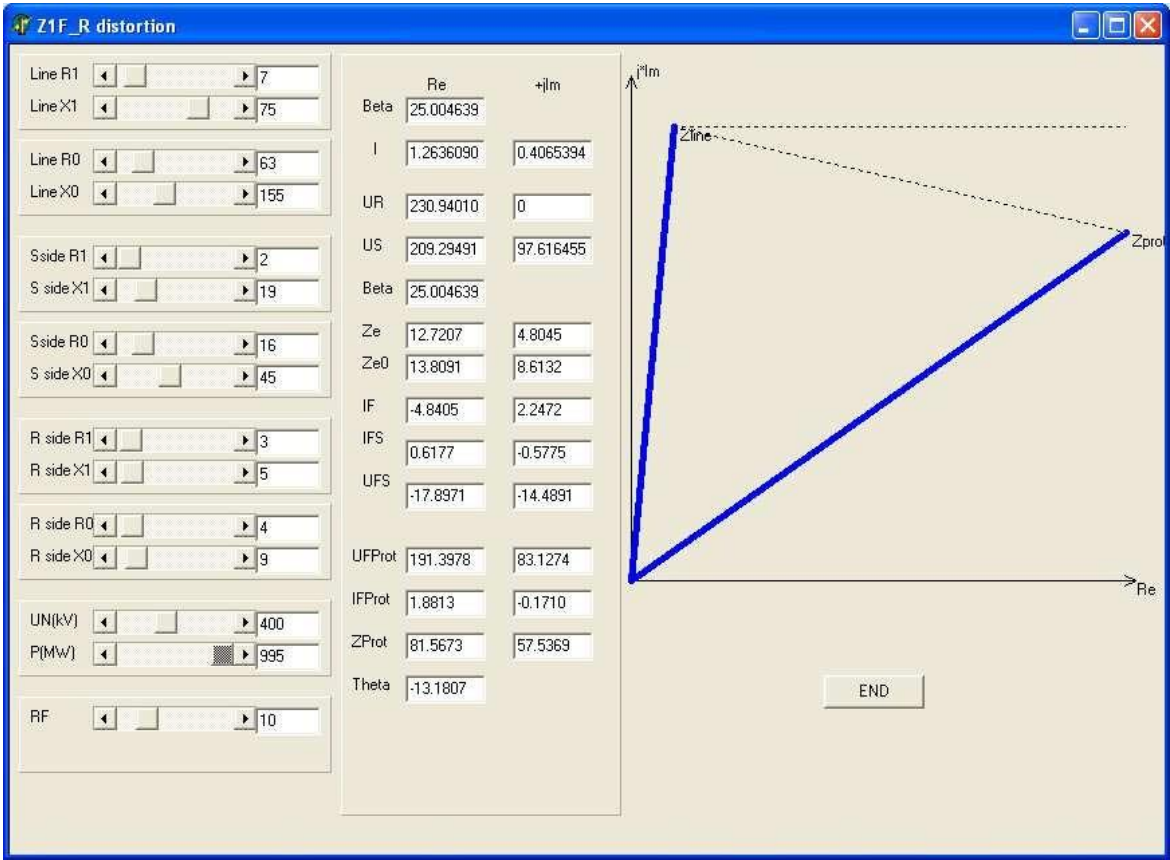

Figure 2-11 Screenshot of the simulation software for phase-to-ground fault

Summary: In a given application, the required tilting of the characteristic can be calculated using the method above. The dynamic tilting of the algorithm applied in the EuroProt devices results less overreaching or underreaching if the pre-fault power transfer is high on the protected line.

5. Maintenance guide for EuroProt+ devices

5.1. Foreword

The EuroProt+ devices are designed with the most up-to-date and durable components available, to keep appliances in continuous operation for decades. For this range, the only type of components that can age and lead to equipment failure are the power supply capacitors. Therefore, this document, in addition to suggesting some general steps for planned inspections, contains important information on the inspection of power supply modules.

5.2. Safety precautions

The EP+ protection-family, depending on the type, operates at dangerous power supply voltages (220 VDC, 230 VAC, 60 VDC, 48 VDC).



In all cases where the connections of the appliance are to be installed or opened, the work must be carried out by a suitably qualified person.

In all cases, the first step of activity should be to switch off the power



The EuroProt+ protection family has a high operating internal temperature. Operations carried out immediately after operation may lead to dangerous burns.



The hardware and software of the EP+ protection family form a complex system. Setting, modifying, and mounting the individual components may severely affect the operation of the whole system.

In all cases where the device is to be operated or maintained, the activity must be carried out by qualified personnel only

5.2.1. General guidelines for a scheduled maintenance of EP+ devices

1. As a first step, it is recommended to send an email attaching a report.zip file to the Protecta Application Department on the email address application@protecta.hu. In the report file, the logs contain information that can indicate abnormal operation of a module before it causes an operational fault. Based on this information, Protecta can make recommendations for the replacement or repair of the modules concerned.



The report.zip file can be downloaded from the device's web interface, in the Backup / Report section of the Advanced / Status / Log menu, by pressing the "Get file" button. Attention! The file size should be about 700kB. If the downloaded file size is significantly smaller than this, please try again or contact Protecta's Application Department via our web-based support system (<https://support.protecta.hu/?language=English>)!

2. It is usually recommended to update the firmware of the devices during scheduled maintenance. Information about the new firmware releases can be found in the [Release Notes on the Protecta homepage](#). The information here can be used to consider upgrading the basic software for a single device, or all devices in a substation.



Before starting the upgrade, always contact the Protecta Application Department or submit a ticket in the web-based support system from the following link: <https://support.protecta.hu/>

For more details on the firmware update, please refer to Chapter 4.2.10.4 of the [EuroProt+ Operating Manual](#).

5.3. Power supply maintenance

Power supplies are designed with the longest possible life electrolytic capacitors. Their expected lifetime depends significantly on the environmental conditions of the device. During a scheduled inspection, we recommend visual inspection of the power supply for any abnormalities in the capacitors. The most common phenomena are: bloating, electrolyte leakage, discoloration, which typically occurs on capacitors, but can also occur on the surface of the PCB board due to leakage. In case of abnormality, the capacitors should be replaced. In such a case, please contact Protecta's Application Department via our support page (<https://support.protecta.hu/>)!

The following figures illustrate the different capacitor states in several photos.



Figure 4-1 The capacitor on the right is already discolored

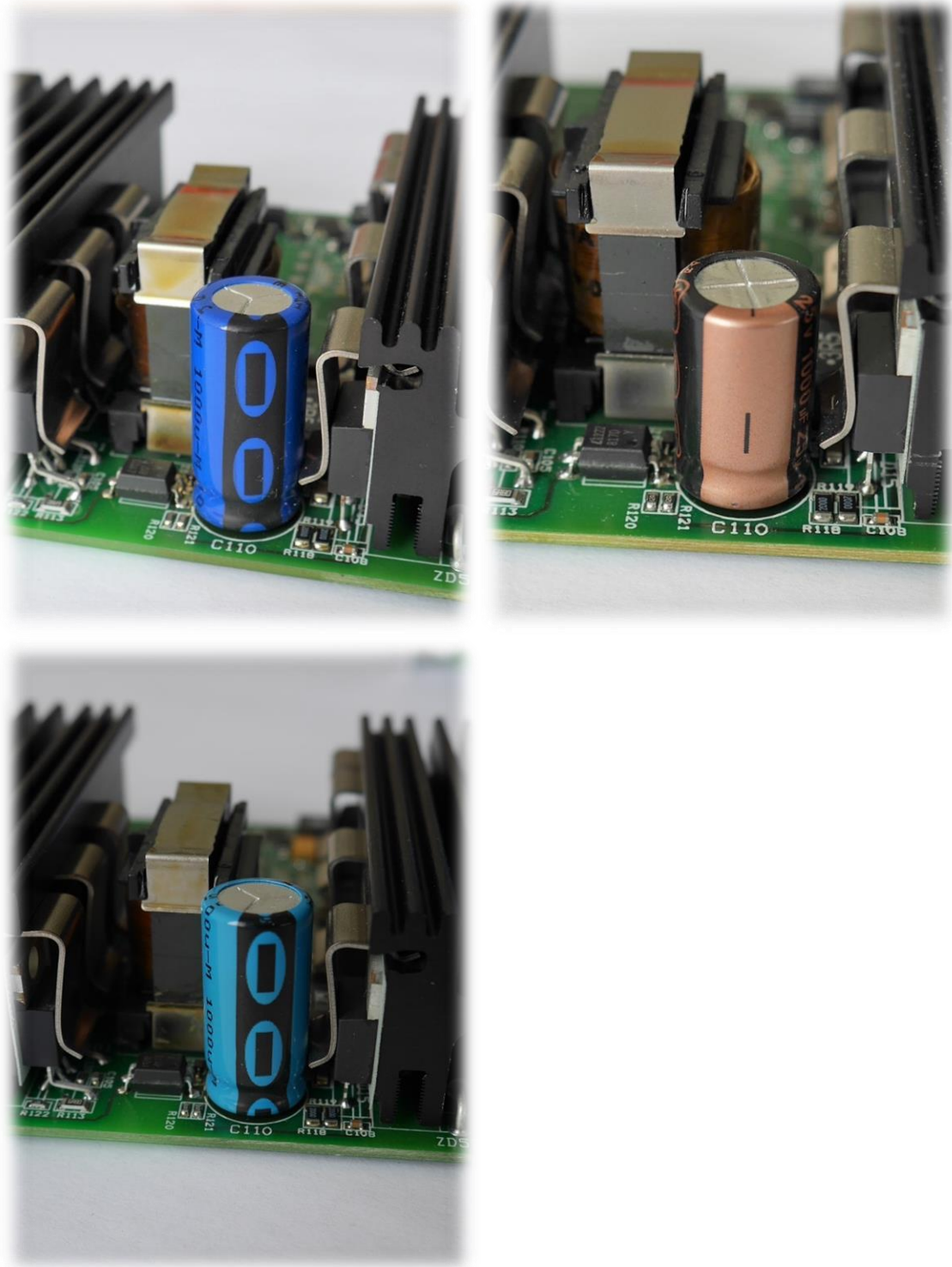

Figure 4-2 Healthy capacitors on visual inspection

C

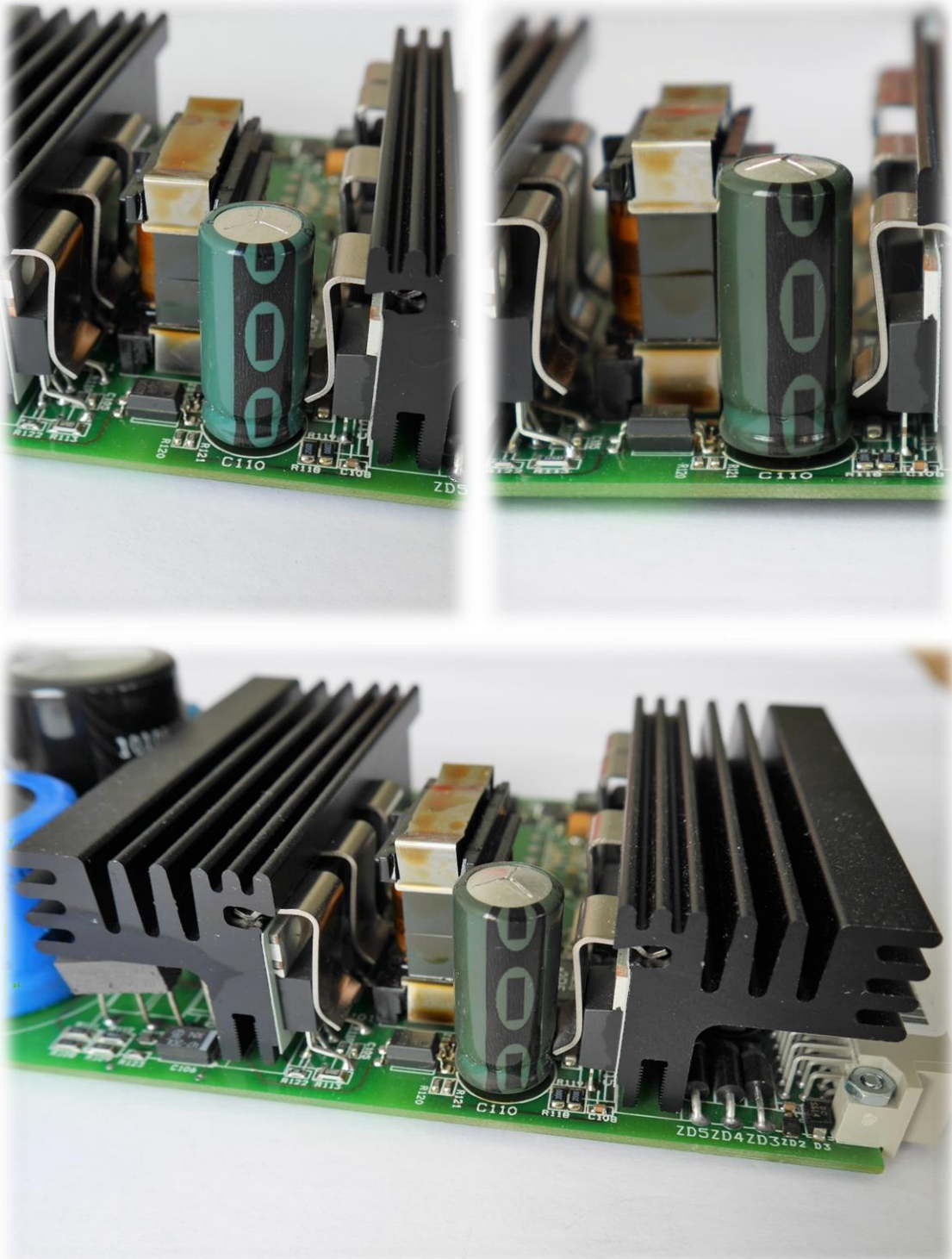

Figure 4-3 Faulty capacitances on visual inspection. The discoloration compared to the original blue color is clearly visible, bloating can be seen on 2 of them

5.4. Elements and Batteries

Az EuroProt+ protection family devices do not contain either a single-use battery or a rechargeable battery.

6. TRIP contact assignment

The outputs of the “phase selective trip logic function” are connected directly to the contacts of the trip module (TRIP+/2101 module in position “O”).

Binary status signal	Title	Connected to the contact TRIP+/2101 module in position “O”
TRC94_GenTr_Grl_	General Trip	Trip

Table 161 The connected signals of the phase-selective trip logic function

To the inputs of the “phase-selective trip logic function” some signals are assigned during factory configuration, some signals however depend on the programming by the user. **The conditions are defined by the user applying the graphic equation editor.** The factory defined inputs and the user defined inputs are in “OR” relationship.

Input	Binary status signal	Explanation
3Ph Trip	DIS21_SOTFTr_Grl_ OR IOC50_GenTr_Grl_ OR IOC50N_GenTr_Grl_	Trip command of the switch onto fault logic OR Trip command of the instantaneous overcurrent protection function OR Trip command of the residual instantaneous overcurrent protection function
1Ph Trip	DIS21_Z1Tr_Grl_ OR DIS21_Z2Tr_Grl_ OR DIFF87L_GenTr_Grl_	First zone trip command of the distance protection function OR Second zone trip command of the distance protection function OR Trip command of the line differential protection function
Trip L1	DIS21_Z1StL1_Grl_ OR DIS21_Z2StL1_Grl_ OR DIFF87L_TrL1_Grl_	First zone L1 trip command of the distance protection function OR Second zone L1 trip command of the distance protection function OR L1 trip command of the line differential protection function
Trip L2	DIS21_Z1StL2_Grl_ OR DIS21_Z2StL2_Grl_ OR DIFF87L_TrL2_Grl_	First zone L2 trip command of the distance protection function OR Second zone L2 trip command of the distance protection function OR L2 trip command of the line differential protection function
Trip L3	DIS21_Z1StL3_Grl_ OR DIS21_Z2StL3_Grl_ OR DIFF87L_TrL3_Grl_	First zone L3 trip command of the distance protection function OR Second zone L3 trip command of the distance protection function OR L3 trip command of the line differential protection function
Fin3Ph	n.a.	Forcing three-phase trip even in case of single-phase fault

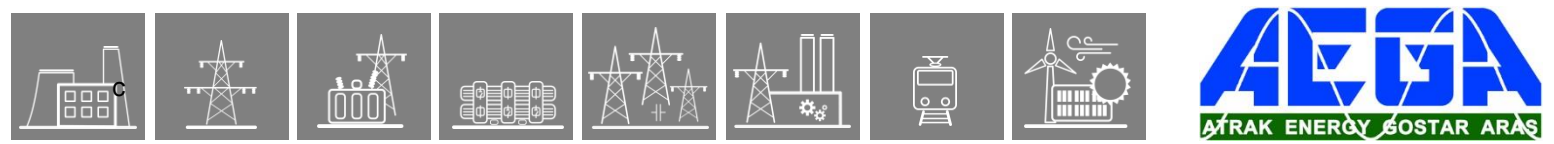

Block	n.a.	Blocking the outputs of the phase-selective trip logic function
-------	------	---

Table 162 The factory defined binary input signals of the trip logic function

The user defined signals are listed in Table 163.

Input	Binary status signal	Explanation
1ph Trip	TRC94_Tr1ph_GrO_	Request for single-phase trip command
3ph Trip	TRC94_Tr3ph_GrO_	Request for three-phase trip command
Block	TRC94_Blk_GrO_	Blocking the outputs of the phase-selective trip logic function

Table 163 The user defined binary input signals of the trip logic function

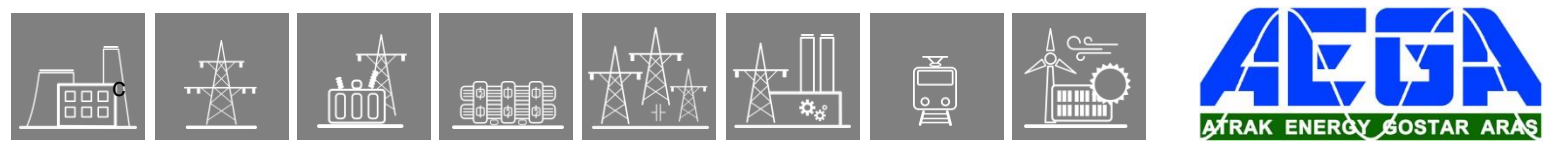

7. LED assignment

On the front panel of the device there are “User LED”-s with the “Changeable LED description label” (See the document “**Quick start guide to the devices of the EuroProt+ product line**”). Some LED-s are factory assigned, some are free to be defined by the user.

LED	Explanation
General Trip	Trip command generated by the trip logic function
Z1 Trip	Distance protection zone 1 trip
Z2 Trip	Distance protection zone 2 trip
Z3 Trip	Distance protection zone 3 trip
Z4 Trip	Distance protection zone 4 trip
Z5 Trip	Distance protection zone 5 trip
Dis Start	Start signal of the
AR Blocked	Blocked state of the automatic reclosing function
OC Trip	Trip command generated by the phase OC protection functions
Res OC Trip	Trip command generated by the residual OC protection functions
Voltage Trip	Trip command generated by the voltage-related functions
Frequ Trip	Trip command generated by the frequency-related functions
LED3113	Free LED
AutoReclose	Close command of auto-reclosing function
LED3115	Free LED
LED3116	Free LED

Table 164 LED assignment

8. External connection

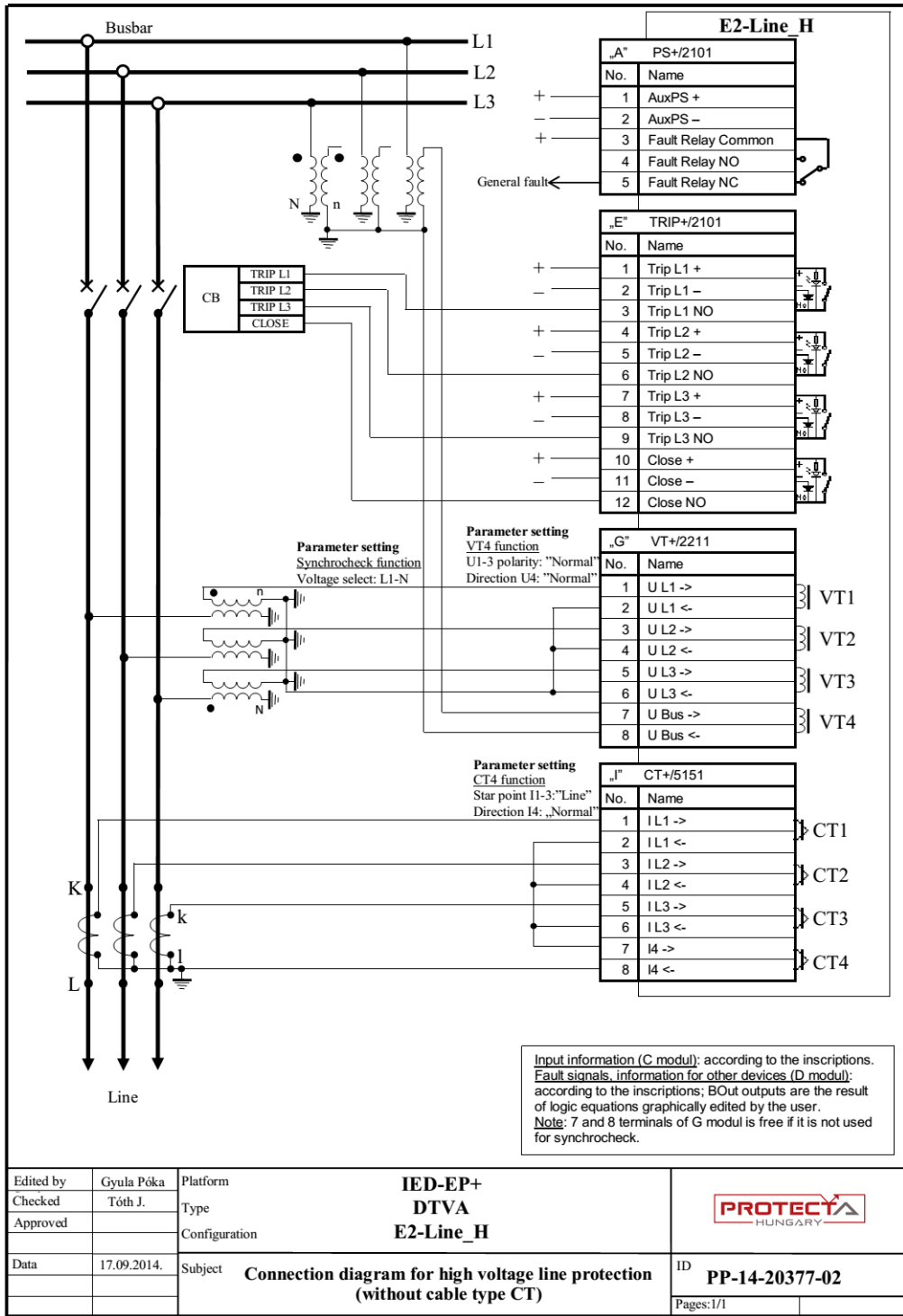

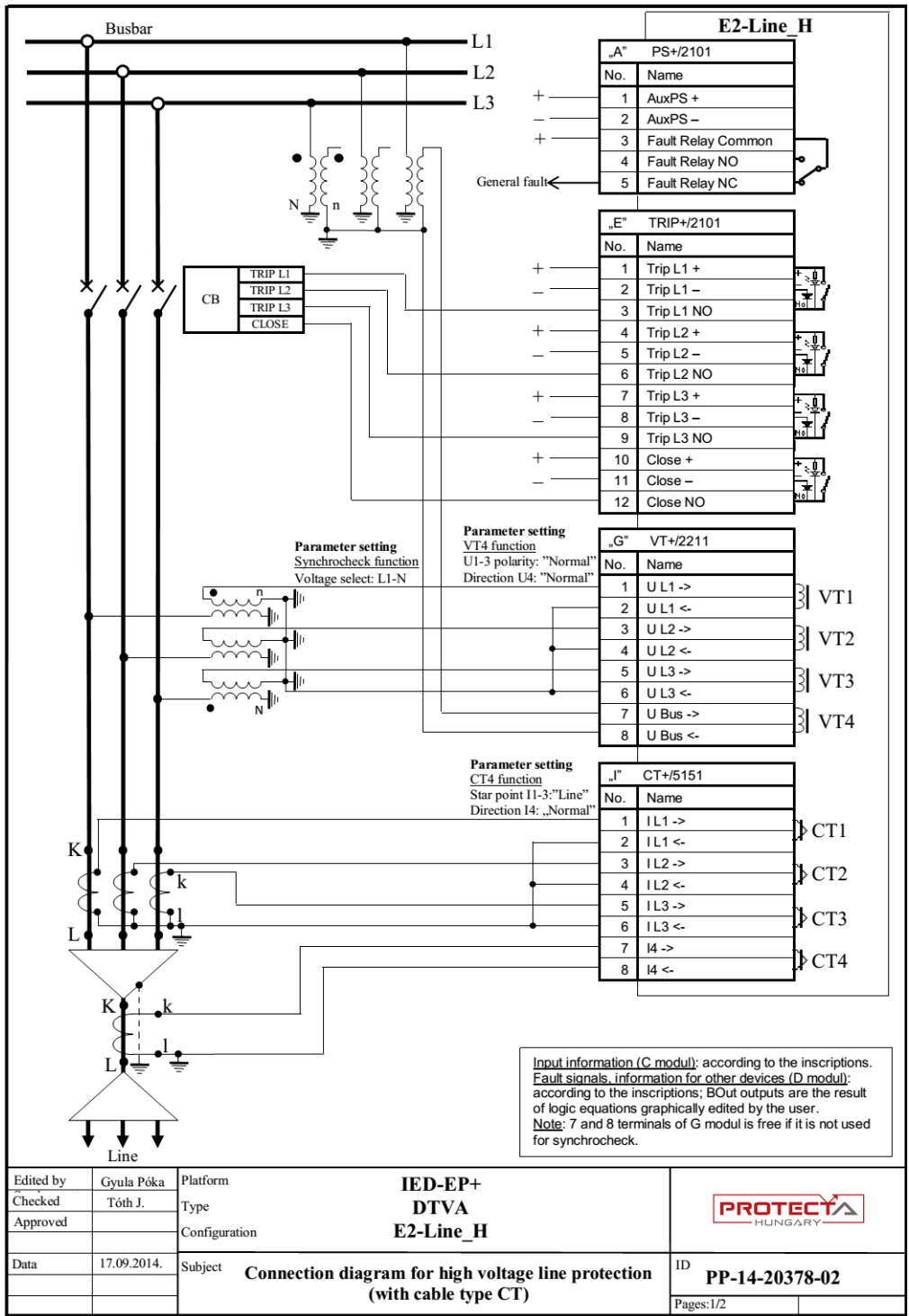

Edited by	Gyula Póka	Platform	IED-EP+ DTVA	
Checked	Tóth J.	Type	E2-Line_H	
Approved		Configuration		
Data	17.09.2014.	Subject	Connection diagram for high voltage line protection (with cable type CT)	ID PP-14-20378-02
				Pages:1/2

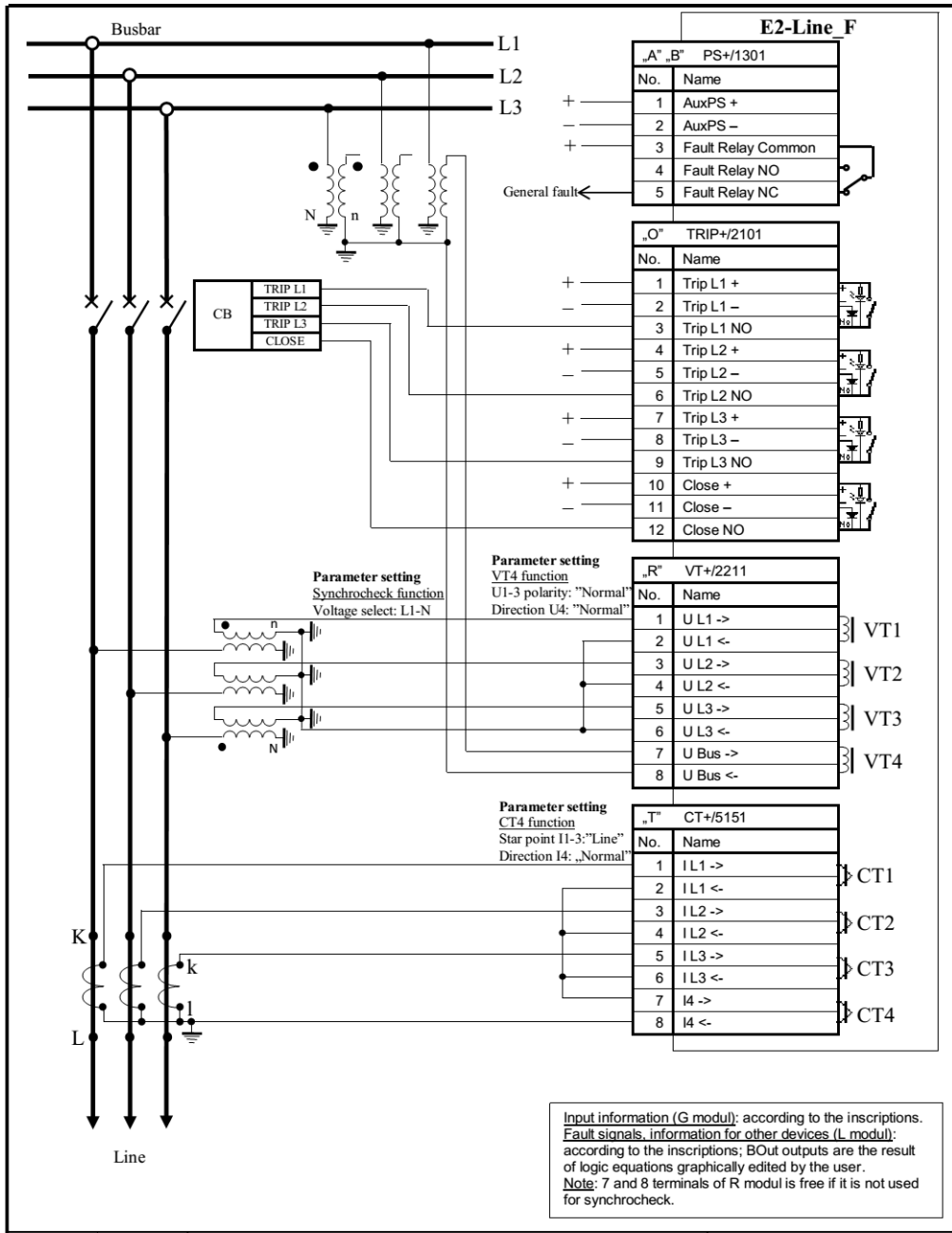

Edited by	Gyula Póka	Platform	IED-EP+	
Checked	Tóth J.	Type	DTVA	
Approved		Configuration	E2-Line_F	
Data	17.09.2014.	Subject	Connection diagram for high voltage line protection (without cable type CT)	ID
				PP-14-20375-02
				Pages: 1/1

